

Operator's Handbook

**Monarch®
9855® RFID
Printer**

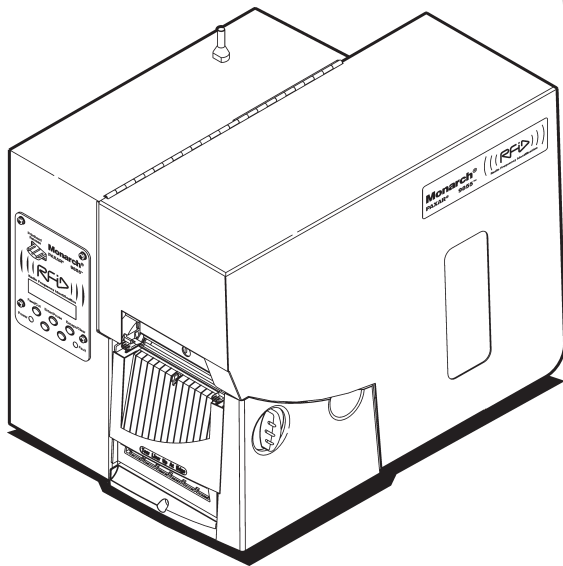

Ship From:
Dayton, Ohio



Ship From:
Dayton, Ohio



Ship From:
Dayton,



**AVERY
DENNISON**

Each product and program carries a respective written warranty, the only warranty on which the customer can rely. Paxar reserves the right to make changes in the product, the programs, and their availability at any time and without notice. Although Paxar has made every effort to provide complete and accurate information in this manual, Paxar shall not be liable for any omissions or inaccuracies. Any update will be incorporated in a later edition of this manual.

©2005 Paxar Americas Inc. a subsidiary of Avery Dennison Corp. All rights reserved. No part of this publication may be reproduced, transmitted, stored in a retrieval system, or translated into any language in any form by any means, without the prior written permission of Paxar Americas, Inc.

WARNING

This equipment has been tested and found to comply with the limits for a Class A digital device, pursuant to Part 15 of the FCC Rules. These limits are designed to provide reasonable protection against harmful interference when the equipment is operated in a commercial environment. This equipment generates, uses, and can radiate radio frequency energy and, if not installed and used in accordance with the instruction manual, may cause harmful interference to radio communications. Operation of this equipment in a residential area is likely to cause harmful interference in which case the user will be required to correct the interference at his own expense.

CANADIAN D.O.C. WARNING

This digital apparatus does not exceed the Class A limits for radio noise emissions from digital apparatus set out in the Radio Interference Regulations of the Canadian Department of Communications.

Le présent appareil numérique n'émet pas de bruits radioélectriques dépassant les limites applicables aux appareils numériques de la classe A prescrites dans le Règlement sur le brouillage radioélectrique édicté par le ministère des Communications du Canada.

Trademarks

Monarch® and 9855 are trademarks of Paxar Americas, Inc.

Paxar® is a trademark of Paxar Corporation.

Avery Dennison® is a trademark of Avery Dennison Corporation.

EPCglobal, Inc.™ and Electronic Product Code™ (EPC) are trademarks of Uniform Code Council, Inc.

Uniform Code Council, Inc.® is a trademark of Uniform Code Council, Inc.

I CODE® is a registered trademark of Philips Electronics N.V.

TABLE OF CONTENTS

GETTING STARTED	1-1
Audience	1-2
Using this Manual	1-2
Unpacking the Printer	1-3
Shipping the Printer	1-3
9445™ Printer Online Emulation	1-4
Ordering Programmer's Manuals	1-4
About Monarch® MPCL™ Toolbox Utilities	1-4
Connecting the Power Cable	1-4
Establishing Communications	1-5
Connecting the Communication Cable	1-5
Using the Control Panel	1-6
Printer Status Lights	1-6
Button Functions	1-6
Display	1-7
Selecting a Function	1-7
Exiting an Option	1-8
LOADING SUPPLIES	2-1
Loading Labels or Tags	2-2
Loading Labels for the Optional Peel Mode	2-6
Adjusting the Wide/Narrow Knobs	2-8
LOADING RIBBON	3-1
Loading Ribbon	3-2

SETTING SUPPLY OPTIONS	4-1
Supply Type	4-3
Ribbon	4-4
Speed	4-5
Feed Mode	4-6
Backfeed	4-7
Positioning	4-8
Print Position	4-8
Supply Position	4-10
Margin Position	4-11
Cut Position	4-12
Dispense Position	4-12
Backfeed Distance	4-13
Batch Separators	4-14
Skip Index	4-15
Knife Control	4-16
Error Action	4-17
Setting Contrast	4-20
Verifier	4-21
Verifier	4-22
SETTING COMMUNICATIONS	5-1
Baud Rate	5-2
Word Length	5-2
Stop Bits	5-3
Parity	5-3
Flow Control	5-4
Reset to Default Values	5-4
Parallel Communications	5-5
Port	5-5
Mode	5-6

SETTING DEFAULTS	6-1
Monetary Sign	6-3
Secondary Sign	6-4
Decimal Places	6-5
Slashed Zero	6-5
Power-Up Mode	6-6
Prompt Set	6-6
Flash Storage	6-7
No Image Errors	6-8
Ignore Configuration.....	6-9
Using Flash Memory.....	6-10
Formatting Flash Memory	6-10
Checking Available Flash Memory	6-11
Packing Flash Memory	6-12
Memory Guidelines	6-13
Setting Batch Options.....	6-14
Setting Up the Network Printer	6-14
Setting Up the RFID Printer	6-14
USING SCRIPTS	7-1
Initial Script Startup Procedures	7-1
Viewing Script Information	7-2
Downloading a Script	7-3
Enabling a Script	7-4
Deleting a Script.....	7-5
Enabling Status Polling.....	7-6
Using Immediate Commands	7-7

PRINTING	8-1
Printing	8-1
On-Demand Mode Printing	8-2
Printing an Error Label	8-2
Pausing a Batch.....	8-3
Restarting a Batch	8-3
Canceling a Paused Batch	8-4
Repeating a Batch.....	8-6
Offline Printing	8-6
Special Printing Considerations	8-7
Printing TrueType® Fonts	8-8
Licensing Your Fonts.....	8-8
CARE AND MAINTENANCE	9-1
Label Jams.....	9-1
Cleaning	9-1
Replacing the Printhead	9-5
DIAGNOSTICS AND TROUBLESHOOTING	10-1
Factory Set Password.....	10-1
Checking the Software Version	10-1
Printing a Test Label	10-2
Checking Supply Quality	10-3
Using Password Protection	10-4
Enabling the Password (System Administrators only).....	10-4
Service Diagnostics.....	10-5
Troubleshooting	10-6
Error Messages	10-8
Common Errors.....	10-8

SPECIFICATIONS	A-1
Printer	A-1
RF Specifications	A-2
RFID Supply Specifications	A-2
Tag Cut Dimensions	A-3
Ribbon Specification	A-3
About Ribbons	A-3
Cable Pinouts	A-4
ACCESSORIES AND OPTIONS	B-1
Accessories	B-1
Packaging Materials	B-2
Factory-Installed Options	B-2
Ethernet Information	B-3
RF Information	B-3
GLOSSARY	G-1

GETTING STARTED

1

Your Monarch® 9855® RFIDMP (Radio Frequency Identification Multi-Protocol) printer has been engineered to program (encode) an RFID label (commonly called “RFID tags”) before the label’s format is printed. RFID tags contain an embedded RFID inlay (chip and antenna).

You can also print text, graphics, and bar codes on thermal transfer (ribbon) and thermal direct labels or tags. The printer prints labels continuously (in one strip) or on-demand (one label at a time). Linerless supplies are not currently supported. The RFID printer is also capable of printing standard (non-RFID) supplies.

The HF (High Frequency) RFID printer supports multi-protocol encoding, including ISO15693 and I•CODE® UID products.

Note: Information in this document supercedes information in previous versions. Check our Web site (www.paxar.com) for the latest documentation and release information.

Review the terms in the Glossary before you continue.

This chapter includes information about

- ◆ unpacking the printer
- ◆ connecting the power cord
- ◆ connecting the communication cable
- ◆ using the printer's control panel.

Several chapters of this manual have one or more charts showing the printer's menu structure. For example:

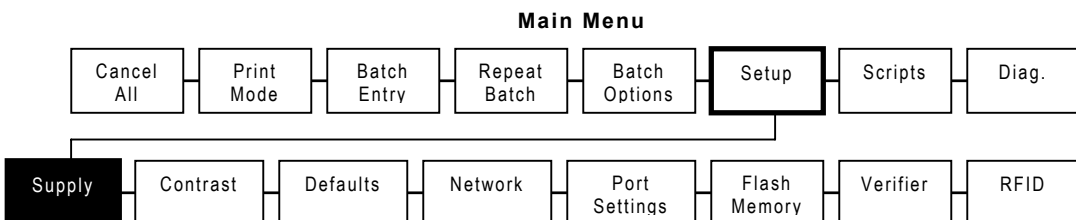

The black boxes show where you are; the bordered boxes show how you got there.

Refer to the *MonarchNet2™ Operating Instructions* for information about the Network menu. Refer to the *Multi-Protocol Application Notes* or the *HF Application Notes* for information about the RFID menu.

Audience

The *Operator's Handbook* is for the person who prints and applies labels. For information about creating RFID formats or programming the RFID printer, refer to the *Multi-Protocol Application Notes* or the *HF Application Notes* on our Web site.

Using this Manual

Following is a summary of the contents of this manual.

Chapter		Contents
1	Getting Started	Contains information about connecting the power cable and using the control panel.
2	Loading Supplies	Describes how to load a roll of supply, fan-fold supply, and tag supply.
3	Loading Ribbon	Describes how to load a roll of ribbon and lists high-energy ribbon information.
4	Setting Supply Options	Using the Supply menu to set the various supply options (supply, ribbon, feed mode, etc.).
5	Setting Communication Values	Using the Port Settings menu to set the serial and parallel communication values (baud rate, parity, etc.).
6	Setting Defaults	Using the Defaults menu to set the monetary sign, number of decimal places, prompt set, etc.
7	Using Scripts	Using the Scripts menu to load a script, enable a script, delete a script, etc.
8	Printing	Explains how to print labels and use the Pause menu.
9	Care & Maintenance	Describes how to clear a label jam, clean the printer, and replace the printhead.
10	Diagnostics & Troubleshooting	Describes how to print a test label and lists common problems and their solutions.
A	Specifications	Contains printer and supply specifications.
B	Accessories & Options	Contains printer accessories and optional equipment.

Unpacking the Printer

After you unpack the printer, you should have the printer, a power cord, and a ribbon take-up core (may already be on take-up reel). Keep the box and packaging material in case the printer ever needs repair.

Shipping the Printer

If you need to ship the printer to a different location:

1. Remove the ribbon roll, if one is loaded.
2. Remove the supply roll, if one is loaded.
3. Close the printhead by pressing down on the thumb well until you hear it click into place.

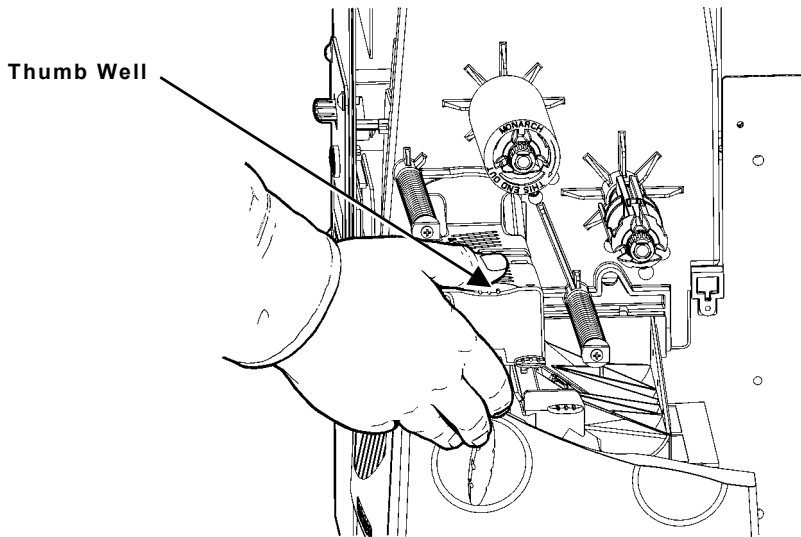

4. Place the printer in the original box and secure with packaging material. **Make sure the printer is adequately packed to avoid damage during shipment.** See Appendix B, "Accessories and Options" for the packaging materials part numbers.

9445™ Printer Online Emulation

The 9855 printer using 203 dpi (dots per inch) printing supports 94x5 emulation. You can send 94x5 data streams to this printer.

Refer to your 9445 *Programmer's Manual* for information about 94x5 data streams.

Ordering Programmer's Manuals

The *Packet Reference Manual*, which describes how to create format and batch packets for printing labels, how to configure the printer online, how to diagnose printer error messages, and how to perform other advanced techniques can be downloaded from our Web site. You can print this manual or order a hard-copy version (part number TC9800PM).

About Monarch® MPCL™ Toolbox Utilities

The Monarch® MPCL™ Toolbox utilities are available on our Web site and are free to download. This group of development utilities helps you configure the printer, customize fonts, and download files. Monarch MPCL Toolbox utilities are not label production software. Call Customer Service for information about label production software.

Connecting the Power Cable

The power supply automatically switches between 115V or 230V. No operator settings are required.

1. Plug the power cable into the socket. Plug the other end of the cable into a grounded electrical outlet.

Note: Only use a certified power cable with proper voltage for the country of installation.

2. Turn on the printer. Press (I) to turn on and (O) to turn off the printer.

Establishing Communications

Before the printer can accept print jobs from the host, you must:

- ◆ Connect the communication cable to the printer and to the host.
- ◆ Set the communication values on the printer to match those at the host. (Only required if you are using the serial port.)
- ◆ Make sure the printer is off before connecting the cable to the communication port.

Ask your System Administrator which method you will use to communicate with the host:

Serial Communication

9 to 25-pin cable

(Part #126825)

25 to 25-pin cable

(Part #126826)

Parallel Communication

IEEE-1284 or

Centronics® mode cable (Part #126805)

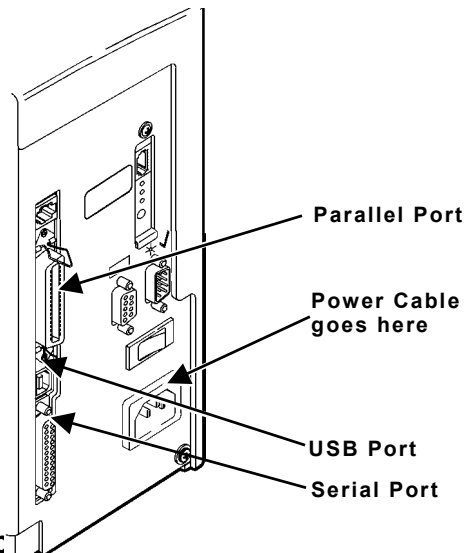

Connecting the Communication Cable

Connect the communication cable into the appropriate port. Secure the cable with the connecting screws (serial) or spring clips (parallel).

If you are communicating with the host through the serial port, make sure the printer's communication values match those at the host. The factory default values are 9600 Baud, 8 bit data frame, 1 stop bit, no parity, and DTR flow control.

The printer also has a USB (Universal Serial Bus) version 2.0 communication port, which is backwards compatible with version 1.1. Drivers are available on our Web site for a variety of operating systems.

Note: The printer supports a baud rate up to 115200. Make sure your host is capable of communicating at the speed you select for the printer.

Using the Control Panel

The control panel has a two-line LCD display, 2 status lights, and five buttons. The control panel displays error codes/messages, and allows you to setup/configure the printer.

Printer Status Lights

Power:

The printer shows a steady green light when it is on.

Fault:

The printer shows a blinking amber light when there is a printer error.

Button Functions

Feed/Cut:

- ◆ Prints a label in the on-demand mode.
- ◆ When the printer is online, feeds a label when there is no print job.
- ◆ Prints a label with error information that is useful to your System Administrator if an error is displayed.
- ◆ When the printer is online, cuts the supply when pressed and held for two seconds if a knife is installed.
- ◆ When the printer is offline, changes the displayed value by one or 10.

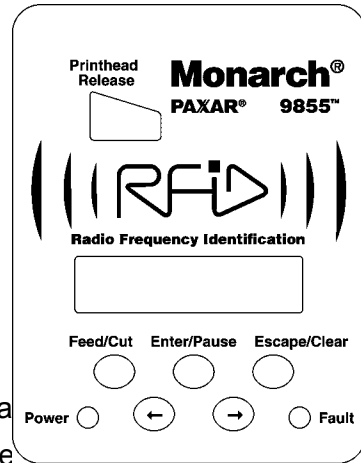

Enter/Pause: When the printer is online, pauses the current print job or resumes a paused print job. When the printer is offline, selects the displayed menu item.

- Escape/Clear:**
- ◆ When an error is present, clears the error.
 - ◆ When a job (batch) is printing, cancels the print job (batch). See "Canceling a Paused Batch" in Chapter 8 for more information.
 - ◆ When the printer is online (without errors), enters the offline menu mode.
 - ◆ When the printer is in the offline menu mode, returns the display to the next higher menu.

← When the printer is in the offline menu mode, displays the previous menu item.

→ When the printer is in the offline menu mode, displays the next menu item.

← and → In online mode, prints a test label when you press the buttons at the same time. Hold for one second and release.

Display

The display shows a three-digit error code and brief message to identify any problem the printer may have. For a description of the problem, look up the error code in Chapter 10, "Diagnostics and Troubleshooting."

Selecting a Function

The Main menu has several functions (operating modes). These functions are shown in the chart below.

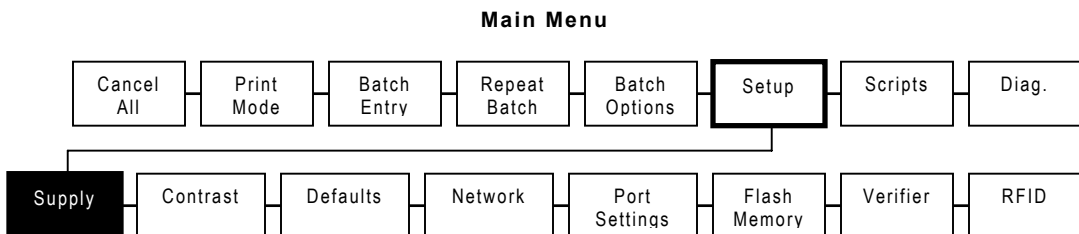

Note: If the printer displays PRINT MODE Ready when you turn it on, press **Escape/Clear** to display the Main menu.

To display menu options, press **←** or **→**.

- ◆ When the screen displays a right arrow, press **→** to display more options.

MAIN MENU Cancel All →

- ◆ When the screen displays a left arrow, press **←** to display more options.

MAIN MENU ← Diagnostics

- ◆ When the screen displays a left and a right arrow, press either **←** or **→** to display more options.

MAIN MENU ← Print Mode →

- ◆ When you see the menu option you want, press **Enter/Pause** to select it.

The Main Menu controls the printer's setup and operation. Through the Setup Menu, you can select a sub-menu for the supply, contrast, default, or port settings. Each of those sub-menus have several options, such as ribbon, speed, monetary symbols, and baud rate.

Exiting an Option

To exit an option, press **Escape/Clear** once. You will exit to the next higher menu.

Note: If you press **Escape/Clear** from a menu, your settings are not saved. Your settings are only saved when you press **Enter/Pause** from a menu.

LOADING SUPPLIES

2

This chapter describes how to load:

- ◆ a roll of supply
- ◆ fan-fold supply
- ◆ a roll of tag supply.

There are two types of supplies:

Thermal Direct specially treated thermal supplies that do not use a ribbon for printing.

Thermal Transfer standard supplies that require a ribbon for printing.

If you are using thermal direct supplies, do not load a ribbon.

Refer to the *9855 Operator's Handbook* for additional supply loading instructions if using non-RFID supplies in your RFID printer.

Loading Labels or Tags

Make sure the printer is configured for the correct supply type.

1. Open the cover.
2. Unlock the printhead by turning the retaining latch.

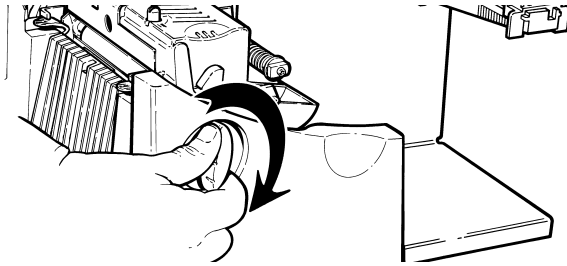

3. Lift printhead assembly using the printhead tab until the assembly locks into place.

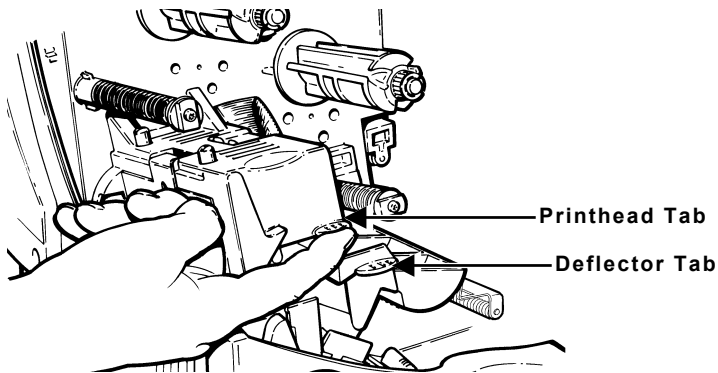

4. Place the roll of supply on the supply holder. For labels, the supply unrolls from the top or the bottom. For tags, make sure the supply unrolls from the bottom, because tag rolls are wound face in.

Note: Do not pick up the printer by the supply holder.

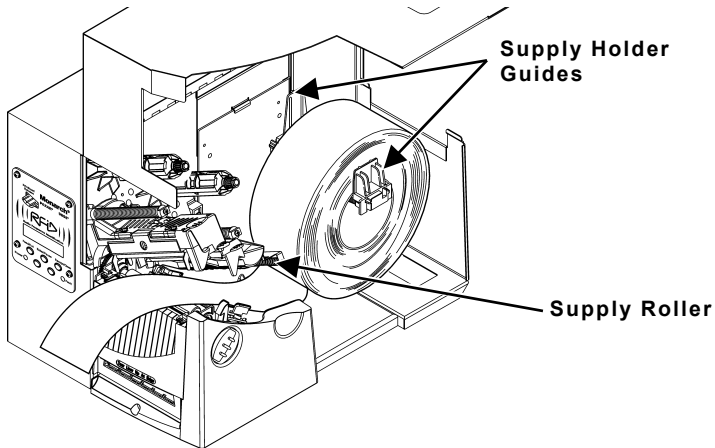

5. Adjust the supply holder guides so the sides barely touch the roll. Make sure the supply roll turns freely.

If you are using fan-fold supplies, place the supply stack behind the printer, label side facing up.

6. Push down on the supply lever to unlock the supply guides.
7. Lay the label strip across the supply guide so that a few inches extend past the front of the printer. Tuck the supply under the nibs and in between the die cut sensor. **Do not feed supply between the supply roller and deflector.**

For fan-fold supplies, lay the label strip over the supply holder and across the supply guide so that a few inches extend past the front of the printer. Tuck the supply under the nibs and in between the die cut sensor.

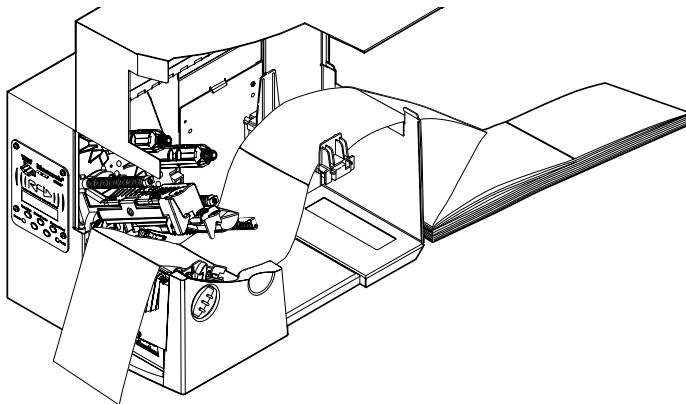

For tag supplies using the optional knife, feed the supply through the knife. Make sure at least 0.5 inches of supply is past the knife.

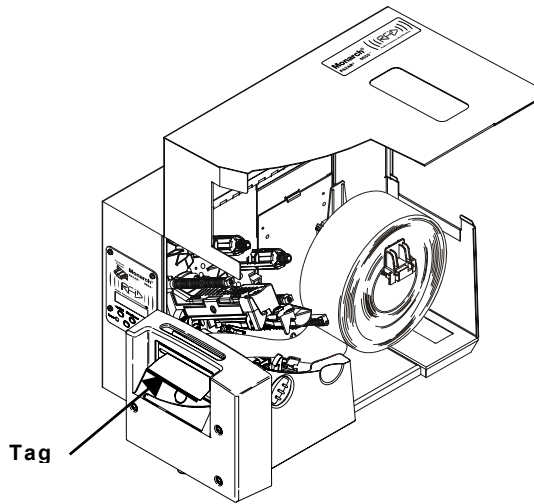

- 8.** Adjust the supply guides so they touch the supply. Push up on the supply lever to lock the supply guides into place.

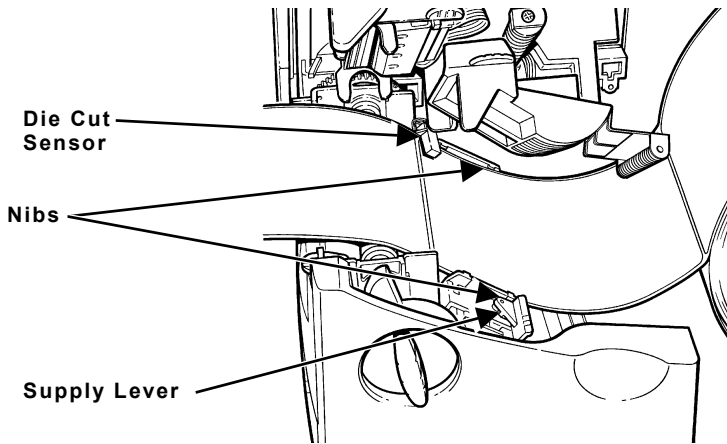

9. Hold the printhead assembly by the printhead tab while pressing down on the printhead release.

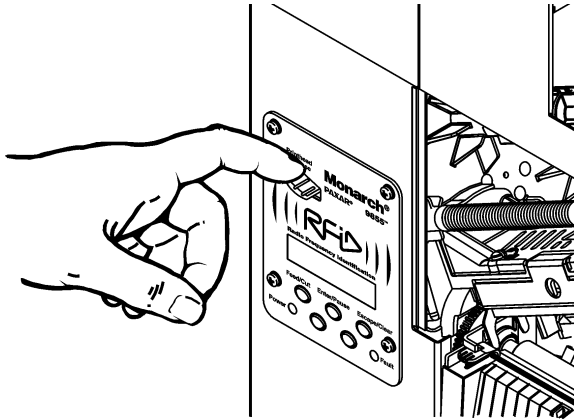

10. Close the printhead by pressing down on the thumb well until you hear it click into place.

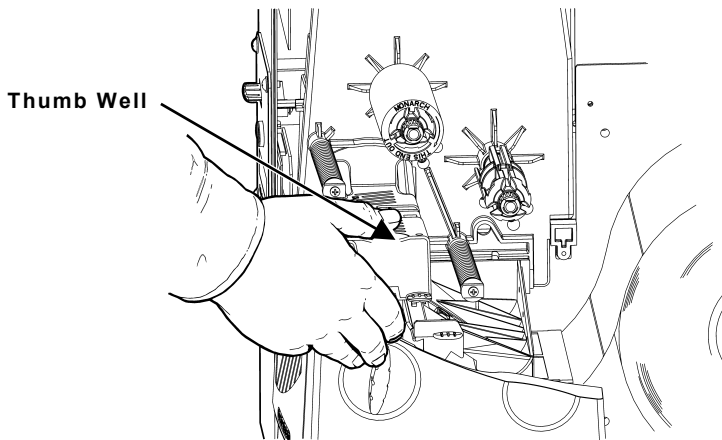

11. Close the cover.

12. Press **Feed/Cut** to position the supply under the printhead.

You may need to adjust the wide/narrow knobs depending on the width of your supply. See "Adjusting the Wide/Narrow Knobs" for more information.

Note: If the printer will be unused for extended periods of time, we recommend leaving the printhead unlatched.

Loading Labels for the Optional Peel Mode

Peel mode is an option that must be purchased separately. In peel mode, the printer separates the backing paper from the label. The next label is not printed until the completed one is removed from the printer. Make sure the printer is configured for on-demand mode and the correct supply type.

The minimum feed length is 1.5 inches for peel mode. We recommend using 0.5-inch gap supplies in peel mode when backfeed is disabled. Hold the leading edge of peeled labels when printing on stock longer than six inches. You must use non-perforated supplies for peel mode. Follow the steps for loading supplies from the previous section. Then, follow these steps after you close the printhead.

1. Remove the labels from the first 10 inches of the backing paper.
2. Press down on the exit cover tabs to open the exit cover on the front of the printer.

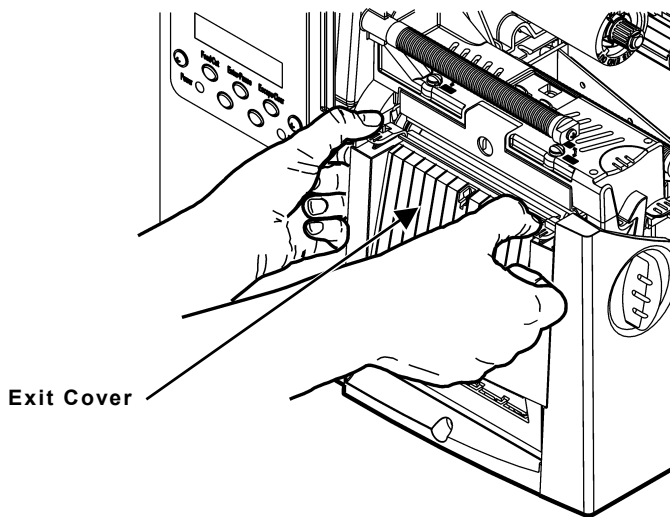

3. Feed the backing paper over the peel bar.

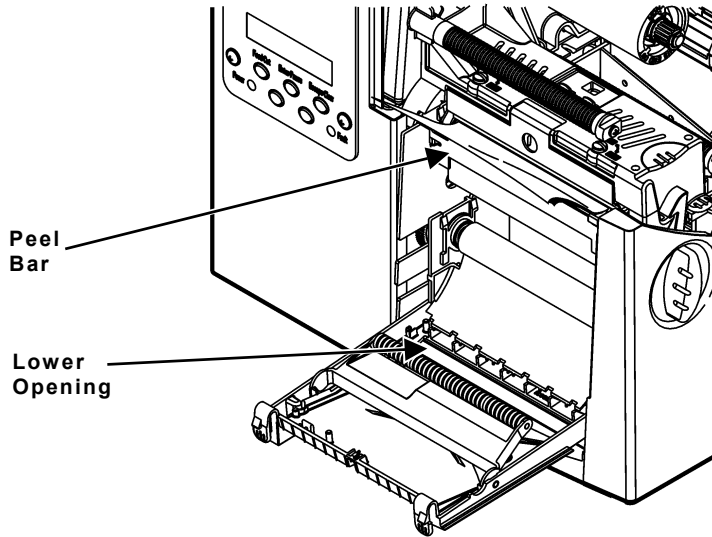

4. Feed the backing paper through the lower opening of the exit cover. Close the exit cover. Pull down on the backing paper to remove any slack.

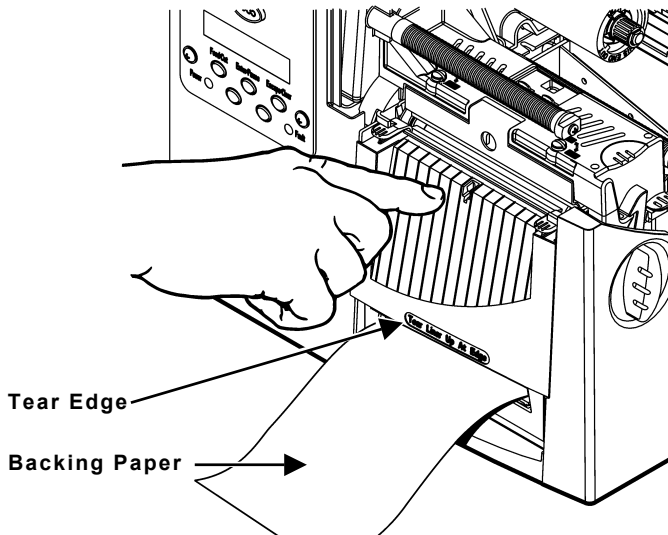

When removing the backing paper, pull up across the saw-toothed tear edge. Make sure the backing paper tears at the edge.

5. Close the printer's cover.
6. Press **Feed/Cut** to position the supply under the printhead.

Adjusting the Wide/Narrow Knobs

You may need to adjust the two wide/narrow knobs according to the width of your supply. For supply that is more than two inches, adjust the knobs to the wide setting. For supply that is two inches or less, adjust the knobs to the narrow setting.

You must adjust both of the knobs to the same position.

If you experience ribbon smudging in cold, dry environments, adjust the wide/narrow knobs to the wide setting.

For wide supplies, push down and turn the wide/narrow knobs clockwise with a screwdriver.

For narrow supplies, turn the wide/narrow knobs counter-clockwise with a screwdriver until it pops back up.

Note: The adjustment is shown in the wide position.

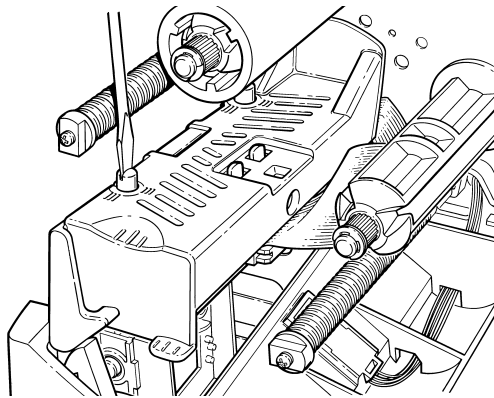

LOADING RIBBON

3

This chapter describes how to load a ribbon roll.

There are different ribbon requirements for the two types of supplies:

Thermal Direct Supplies do not use a ribbon for printing.

Thermal Transfer Supplies require a ribbon for printing.

Refer to the *9855 Operator's Handbook* for additional ribbon information if using non-RFID supplies in your RFID printer.

Loading Ribbon

Make sure the printer is configured to use a ribbon.

To load ribbon:

1. Open the cover.
2. Unlock the printhead by turning the retaining latch.
3. Lift printhead assembly using the printhead tab until the assembly locks into place.

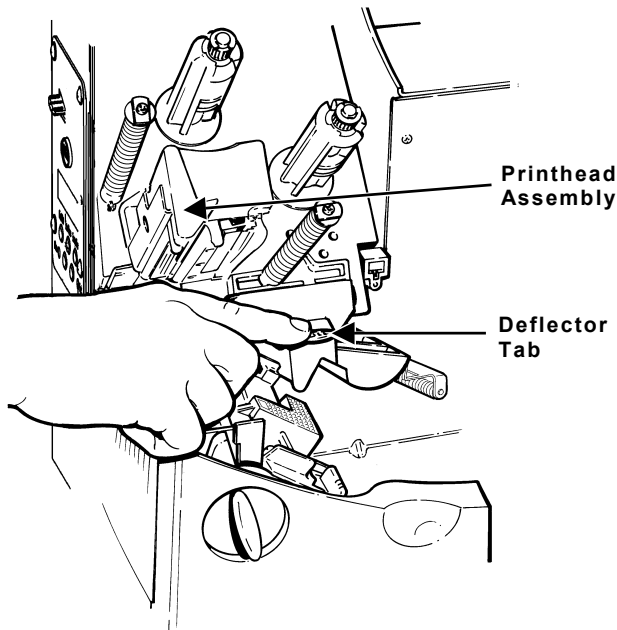

4. Push the deflector tab down.
5. Slide the extra ribbon core on the take-up reel as far as it will go with the "This End Out" writing facing out. Use your empty ribbon core as the take-up core. The take-up core only fits on the take-up reel one way. (An extra take-up core is available by ordering part number 117961.)

6. Remove the new ribbon from the package as shown. Do not wrinkle or crush the new ribbon.

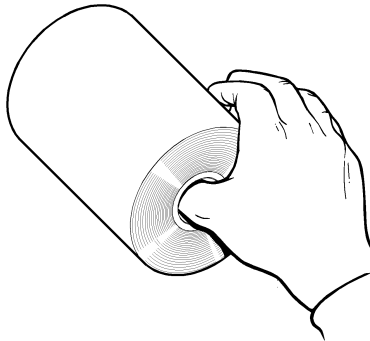

7. Slide the ribbon onto the back reel as far as it will go. The ribbon roll only fits on the reel one way. Carefully unwind a few inches of ribbon from the bottom of the roll.

Note: Make sure the “Monarch This End Out” writing is facing out. The ribbon only fits on the reel one way.

8. Carefully feed the ribbon under both ribbon rollers and printhead as shown.
9. Align the ribbon and make sure it is straight and centered throughout the path.
10. Tape the ribbon to the take-up core. ***Do not tape the ribbon to the take-up reel.***
11. Rotate the take-up core until the leader is past the printhead.

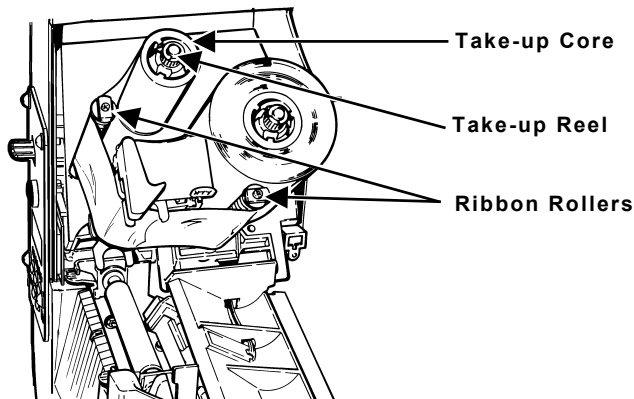

- 12.** Remove any slack in the ribbon by turning the take-up reel clockwise.
- 13.** Hold the printhead assembly by the printhead tab while pressing down on the printhead release.
- 14.** Close the printhead by pressing down on the thumb well until you hear it click into place. Close the cover.

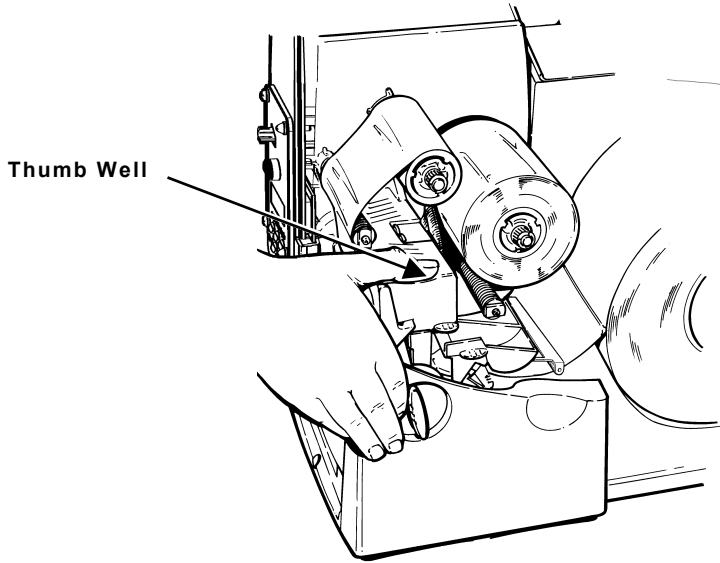

SETTING SUPPLY OPTIONS

4

This chapter explains how to select the supply type, ribbon, speed, feed mode, backfeed, print position, supply position, margin position, cut position, dispense position, backfeed distance, separators, and skip index mode. This chapter also explains how to adjust the print contrast and enable the verifier.

Main Menu

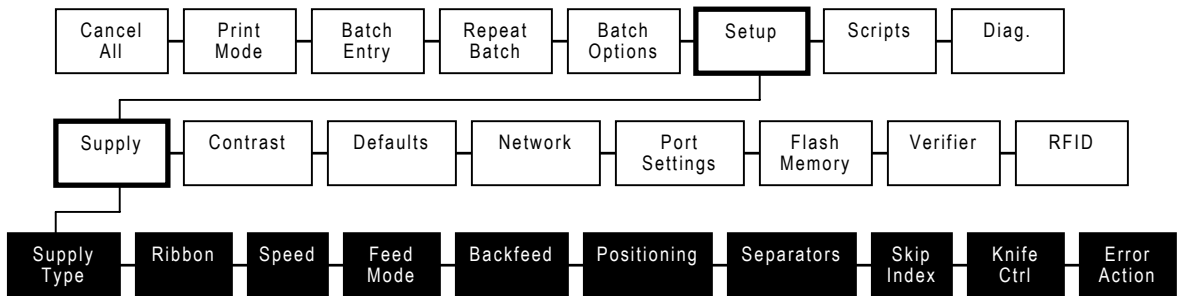

Your System Administrator may limit access to this menu to prevent supply, network, script, or communication settings from being changed. If password protection is turned on, you see

Enter Password
_ _ _ _ _

when you try to access the setup menu. Get the password from your System Administrator to continue.

The options are listed in the table below.

Option	Choices	Default
Supply Type	Aperture/Die Cut/Black Mark/Continuous	Die Cut
Ribbon	No/Yes/High Energy	Yes
Speed	2.5/4.0/6.0/8.0/10.0/12.0/Default	Default
Feed Mode	Continuous/On-Demand	Continuous
Backfeed	Off/On/Extended	Off
Print Position	-450 to 450	0
Supply Position	-300 to 300	0
Margin Position	-99 to 99	0
Cut Position	-300 to 300	0
Dispense Position	50 to 200	65
Backfeed Distance	10 to 200	65
Separators	No/Yes/Long	No
Skip Index	No/Yes	No
Knife Control	-20 to 20	0
Error Action	Normal Overstrike/Continue x1 Overstrike/Continue x2 Overstrike/Continue x3 Overstrike/Continue x4 Overstrike/Continue x5	Normal
Contrast	-699 to 699	0

To exit an option without changing the setting, press **Escape/Clear**.

Supply Type

RFID supplies are die cut or black mark. Refer to the *9855 Operator's Handbook* for additional supply type information if using non-RFID supplies in your RFID printer.

To change the setting, from the Main Menu, select Setup, then Supply. If password protection is enabled, press **Feed/Cut** three times, then press **Enter/Pause** before you see the Setup Menu options. Then, follow these steps.

1. Press **←** or **→** until you see

SUPPLY Supply Type →

2. Press Enter/Pause to set the supply type option. The current setting is displayed, for example:

SUPPLY TYPE ← Die Cut →
--

3. Press **←** or **→** to see the other options. After you display the option you want, press **Enter/Pause**. Press **Escape/Clear** until you see the Main Menu.

Ribbon

You have to tell the printer if your supplies require a ribbon. To change the setting, from the Main Menu, select Setup, then Supply. Then, follow these steps.

1. Press **←** or **→** until you see

SUPPLY Ribbon	→
------------------	----------

2. Press **Enter/Pause** to set the ribbon option. The current setting is displayed, for example:

← RIBBON Yes	→
------------------------	----------

3. Press **←** or **→** to see the other options. After you display the option you want, press **Enter/Pause**. Press **Escape/Clear** until you see the Main Menu.

Note: If you set the Ribbon option to **Yes**, install a ribbon before printing. If you want to use a high energy ribbon, select high energy for the ribbon every time the printer is turned on.

Speed

You can change the print speed for bar codes or graphics. If you select "default" for speed, formats with serial bar codes automatically print at 2.5 ips and formats with parallel bar codes print at 6.0 ips.

Note: The RFID printer pauses while programming the RFID microchip (tag).

To change the setting, from the Main Menu, select Setup, then Supply. Then, follow these steps.

1. Press ← or → until you see

SUPPLY		
←	Speed	→

2. Press **Enter/Pause** to set the speed option. The current setting is displayed, for example:

SPEED		
←	Default	

3. Press ← or → to see the other options. After you display the option you want, press **Enter/Pause**. Press **Escape/Clear** until you see the Main Menu.

Note: For additional high speed printing information, see Chapter 8, "Printing."

Feed Mode

You can use continuous or on-demand printing. On-demand printing allows you to remove a label before printing the next one.

To change the setting, from the Main Menu, select Setup, then Supply. Then, follow these steps.

1. Press **←** or **→** until you see

SUPPLY		
←	Feed Mode	→

2. Press **Enter/Pause** to set the feed mode. The current setting is displayed, for example:

FEED MODE		
	Continuous	→

3. Press **←** or **→** to see the other option. After you display the option you want, press **Enter/Pause**. Press **Escape/Clear** until you see the Main Menu.

Backfeed

Backfeed works by advancing each printed label to the desired dispense position. Once that label is removed, the next label to be printed is backed up underneath the printhead. In continuous mode, only the last label in the batch is advanced to the dispense position. Extended backfeed is available on this printer with a knife installed. Extended backfeed feeds a tag far enough out to be cut and backfeeds the next tag to the printhead line.

Note: We recommend using 0.5-inch gap supplies in peel mode when backfeed is disabled.

To change the setting, from the Main Menu, select Setup, then Supply. Then, follow these steps.

1. Press **←** or **→** until you see

SUPPLY		
←	Backfeed	→

2. Press **Enter/Pause** to set the backfeed option. The current setting is displayed, for example:

BACKFEED		
←	On	→

3. Press **←** or **→** to see the other options. After you display the option you want, press **Enter/Pause**. Press **Escape/Clear** until you see the Main Menu.

Positioning

This menu includes selections to change the print, supply, margin, cut, and dispense positions along with the backfeed distance.

When you see

Enter print pos
[-450/450]: +0

Feed/Cut acts as a toggle switch to change the value by 10 or 1. For example, to make the print position 23 (from the default of 0), press **Feed/Cut**, then press ← twice (20), press **Feed/Cut** again and press → three times (23).

Print Position

This function adjusts where data prints vertically on the supply. Adjust the print if it is too close to the top or bottom of the supply, or overtypes the pre-printed area. One dot is 0.0049 inch.

For RFID supplies with a one-inch feed length, adjust the print position and/or the supply position as shown in the *RFID Setup Guide & Supply Chart* or the *HF Setup Guide & Supply Chart*.

- ◆ If the data is too close to the bottom, increase the number.
- ◆ If the data is too close to the top, decrease the number.

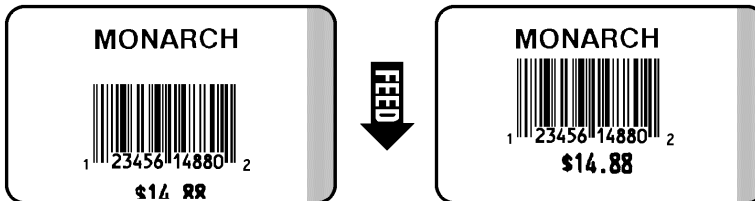

Note: Changing this setting only affects new formats sent to the printer.

To change the setting, from the Main Menu, select Setup, Supply, then Positioning. Then, follow these steps.

1. Press ← or → until you see

POSITIONING
← Print Pos →

2. Press **Enter/Pause**. The current setting is displayed, for example:

Enter print pos [-450/450]: +0

3. Press ← or → to change the print position. Pressing ← decreases the value (moves the image down); → increases it (moves the image up).
4. Press **Enter/Pause** when the number you need appears. Press **Escape/Clear** until you see the Main Menu.

Supply Position

This function adjusts the machine to print at the vertical 0,0 point on the supply.

For RFID supplies with a one-inch feed length, refer to the *RFID Setup Guide & Supply Chart* or the *HF Setup Guide & Supply Chart* to adjust the print position and/or the supply position.

Note: The supply position adjustment should only be made on initial printer setup. For format adjustments, change the print position.

You may need to adjust the supply in or out to allow

- ◆ tags and labels to be removed.
- ◆ die cut labels to be removed easily.

The adjustments are in dots (0.0049 inch).

- ◆ Increase the number to feed more supply out of the chute.
- ◆ Decrease the number to feed less supply out of the chute.

This option takes effect on the next label or tag printed. Changing supply position may also affect print position.

To change the setting, from the Main Menu, select Setup, Supply, then Positioning. Then, follow these steps.

1. Press **←** or **→** until you see



```
POSITIONING
← Supply Pos →
```

2. Press **Enter/Pause**. The current setting is displayed, for example:

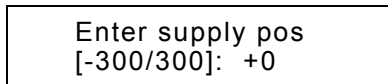

```
Enter supply pos
[-300/300]: +0
```

3. Press **←** or **→** to change the supply position. Pressing **←** decreases the value (feeds less supply); **→** increases it (feeds more supply).
4. Press **Enter/Pause** when the number you need appears. Press **Escape/Clear** until you see the Main Menu.

Margin Position

This function adjusts where the format prints horizontally on the supply. The adjustments are in dots (0.0049 inch), which is the smallest measurement the printer recognizes.

The width of the print area depends on your supply size. Maximum width is four inches. When you move the image to the right or left on the supply, avoid moving the image too close to either edge, because it may not print.

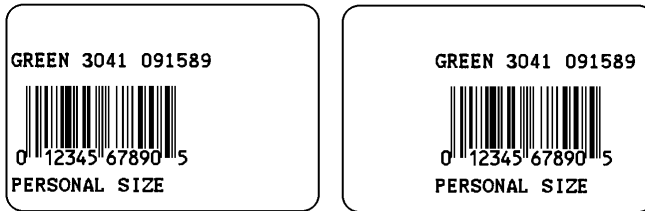

Print too far to the left.

Print too far to the right.

- ◆ If the data is too close to the left side, increase the number.
- ◆ If the data is too close to the right side, decrease the number.

Note: Changing this setting only affects new formats sent to the printer.

To change the setting, from the Main Menu, select Setup, Supply, then Positioning. Then, follow these steps.

1. Press **←** or **→** until you see



2. Press **Enter/Pause**. The current setting is displayed, for example:

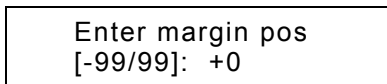

3. Press **←** or **→** to change the margin position. Pressing **←** decreases the value (moves the image toward the left side of the supply); **→** increases it (moves the image toward the right side of the supply).
4. Press **Enter/Pause** when the number you need appears. Press **Escape/Clear** until you see the Main Menu.

Cut Position

This function adjusts where the tag is cut. The printer adjusts the cut position according to the black marks on the supply. You may need to adjust for aperture supplies. Increase to move the cut up; decrease to move the cut down.

To change the setting, from the Main Menu, select Setup, Supply, then Positioning. Then, follow these steps.

1. Press **←** or **→** until you see

```
POSITIONING
←  Cut Pos  →
```

2. Press **Enter/Pause**. The current setting is displayed, for example:

```
Enter knife adj
[-300/300]: +0
```

3. Press **←** or **→** to change the cut position. Pressing **←** decreases the value (moves the cut down); **→** increases it (moves the cut up).
4. Press **Enter/Pause** when the number you need appears. Press **Escape/Clear** until you see the Main Menu.

Dispense Position

This function adjusts the stopping point of the label.

To change the setting, from the Main Menu, select Setup, Supply, then Positioning. Follow these steps.

1. Press **←** or **→** until you see

```
POSITIONING
←  Dispense Pos  →
```

2. Press **Enter/Pause**.

```
DISPENSE POS
[50/200]: +65
```

3. Press **←** or **→** to change the dispense position. Pressing **←** decreases the value; **→** increases it.
4. Press **Enter/Pause** when the number you need appears. Press **Escape/Clear** until you see the Main menu.

Backfeed Distance

This is the amount to move the label backwards. The backfeed distance cannot be greater than the dispense position. If you make the backfeed distance greater than the dispense position, the dispense position automatically changes to match the backfeed distance.

The backfeed distance should equal the dispense position. An exception is when you are tearing labels, instead of peeling. Then, the backfeed distance must be 30 dots (0.15 inches) less than the dispense position to account for improper tearing of butt cut supplies. You will have a 30-dot non-print zone on your supply, but this prevents exposed adhesive under the printhead.

To change the setting, from the Main Menu, select Setup, Supply, then Positioning. Follow these steps.

1. Press **←** or **→** until you see

```
POSITIONING
← Backfeed Dis
```

2. Press **Enter/Pause**.

```
BACKFEED DIS
[10/200]: +65
```

3. Press **←** or **→** to change the dispense position. Pressing **←** decreases the value; **→** increases it.
4. Press **Enter/Pause** when the number you need appears. Press **Escape/Clear** until you see the Main menu.

Batch Separators

A batch separator is an extra tag printed in between batches with a pinstripe pattern. If you select "Long" for the separator, a double-length (two tags) separator prints. The name of the batch is shown on the batch separator.

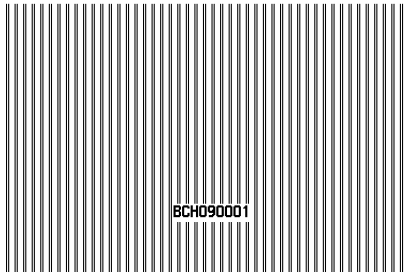

Batch Separator

Since this feature unnecessarily wastes a label, we do not recommend using batch separators with RFID supplies.

Note: Changing this setting only affects new formats sent to the printer.

To change the setting, from the Main Menu, select Setup, then Supply. Then, follow these steps.

1. Press **←** or **→** until you see



2. Press **Enter/Pause** to set the batch separators option. The current setting is displayed, for example:



3. Press **←** or **→** to see the other options. After you display the option you want, press **Enter/Pause**. Press **Escape/Clear** until you see the Main Menu.

Skip Index

You can use the skip index mode to skip (or ignore) a sense mark and print an image over multiple labels, if necessary. For example, if you have 4.0" long supplies loaded, but your image is 8.0" long, enable skip index mode to print the 8.0" long image on two labels. The image length is determined by the format header. See your System Administrator or the optional *Packet Reference Manual* for more information. The skip index feature is useful when you have a **single** format that contains two labels, such as a shelf label and a carton label.

Since this feature unnecessarily wastes a label, we do not recommend using skip index mode with RFID supplies.

Note: When designing the format, make sure text or graphics do not print in the gap of label rolls.

To change the setting, from the Main menu, select Setup, then Supply.

1. Press ← or → until you see

SUPPLY ← Skip Index

2. Press **Enter/Pause** to set the skip index mode. You will see the current setting, for example:

SKIP INDEX No →

3. Press ← or → to see the other options. After you display the option you want, press **Enter/Pause**. Press **Escape/Clear** until you see the Main Menu.

Knife Control

You may notice unevenly cut tags on one end or the other of your supply (one end may appear longer than the other). Use the knife control adjustment to balance the cut tag length from tag-to-tag.

You may need to make this adjustment

- ◆ on initial printer setup.
- ◆ if you load a different supply type (thickness) from the last ones printed.
- ◆ when you change the print speed.
- ◆ when you change to a different tag size from the last ones printed.

To change the setting, from the Main Menu, select Setup, then Supply. Then, follow these steps.

1. Press **←** or **→** until you see

```
SUPPLY
← Knife Ctrl
```

2. Press **Enter/Pause**. The current setting is displayed, for example:

```
Enter knife ctrl
[-20/20]: +0
```

3. Press **←** or **→** to change the knife control. You may need to experiment and cut a few test tags to check the tag cut length. Pressing **←** decreases the value; **→** increases it.

Note: Depending on how unevenly the tags are cut, always start with a small number, such as +- 1 or 2.

4. Press **Enter/Pause** when the number you need appears. Press **Escape/Clear** until you see the Main Menu.

Error Action

You can change how the printer responds to a bad label. The choices include normal and overstrike/continue one to five consecutive bad labels. The overstrike pattern is created to prevent someone from using the label.

Selecting overstrike and continue 1x-5x sets the number of times the printer prints an overstrike pattern on **consecutively bad labels** before generating an error. The user must clear the error before operation can continue.

Consider this scenario when the error action is set to overstrike/continue 3x:

If the printer errors on the first label, an overstrike pattern is printed, but the printer attempts to reprint the image up to three times. If the third consecutive label **also** generates an error, an overstrike pattern is printed; however, the printer stops and the error message is displayed. The operator must resolve the error condition before printing continues.

In the above example, if the third label did **NOT** generate an error,

- ◆ the batch image is printed
- ◆ the consecutive error counter is reset
- ◆ the printer continues processing the batch.

Error Action Modes

Normal (default)

The printer errors and the condition causing the error is displayed. The error must be cleared before operation can continue. An operator must press **Escape/Clear** to clear the error and continue printing. No overstrike pattern is printed.

Overstrike/Continue 1x

Overstrike/Continue 2x

Overstrike/Continue 3x

Overstrike/Continue 4x

Overstrike/Continue 5x

The printer prints an overstrike pattern on one, two, three, four, or five consecutive labels and stops printing after the selected number of overstrike patterns have been printed. An operator must press **Escape/Clear** to clear the error and continue printing.

Note: The printer does **not** recalibrate (feed a blank label) after any RFID error.

For more information about the error actions, see the following table.

Error Action	Standard Peel	Verifier with Peel	RFID with Peel
Overstrike/Continue 1-5	No	No	No
Normal (no overstrike)	Yes	Yes	Yes

Note: If using the Overstrike and Continue error mode, do not use peel mode.

To change the setting, from the Main Menu, select Setup, then Supply. Then follow these steps.

1. Press ← or → until you see

```
SUPPLY
← Error Action
```

2. Press **Enter/Pause**. The current setting is displayed, for example:

```
ERROR ACTION
← Ostrk/Cont 1x →
```

3. Press ← or → see the other options. After you display the option you want, press **Enter/Pause**.
4. Press **Escape/Clear** until you see the Main Menu.

Note: Depending on the selected error action, you may or may not see a label with the overstrike pattern.

If an RFID error occurs, an overstrike pattern is printed on the label without any data.

If a non-RFID error (verifier error) occurs, the data prints on the label with the overstrike pattern.

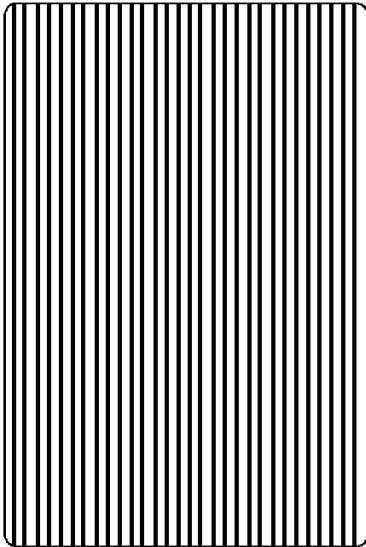

RFID Overstrike



**Non- RFID Overstrike
printed from a verifier
error**

Setting Contrast

The print contrast controls the darkness of the printing on your supply. The range is **-699** to **+699** and the default is **0**. You may need to increase the print contrast for linerless supplies. Having the correct print contrast setting is important because it affects how well your bar codes scan and how long your printhead lasts. You can use a verifier to check the bar code print quality.

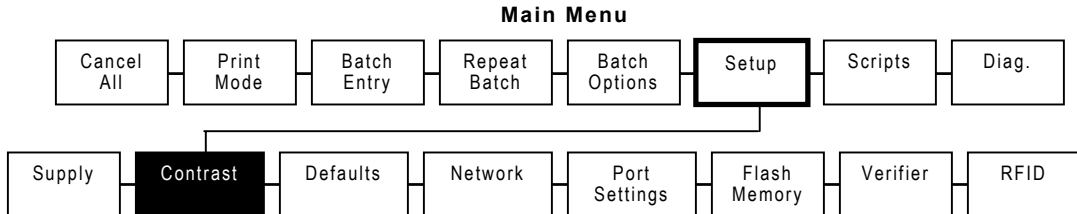

High contrast settings may

- ◆ require additional printhead cleaning.
- ◆ create bar code growth, leading to reduced scanning.

1. From the Main Menu, press **←** or **→** until you see

```
MAIN MENU
← Setup →
```

2. Press **Enter/Pause**. You will be at the Setup menu. Press **←** or **→** until you see

```
SETUP
← Contrast →
```

3. Press **Enter/Pause**. The current setting is displayed, for example:

```
Enter contrast
[-699/+699]: +0
```

4. Press **←** or **→** to change the contrast. Pressing **→** darkens the print; **←** lightens the print.

Feed/Cut acts as a toggle switch to change the value by 10 or 1. For example, to make the contrast 50 (from the default of 0), press **Feed/Cut**, then press → five times (50).

5. Press **Enter/Pause** to select either "Yes" or "No" to print a test label and check the print contrast. Press **Enter/Pause**.
6. Press **Escape/Clear** until you see the Main Menu.

We recommend you check the bar code print quality with a bar code verifier. If you do not have a bar code verifier or scanner, check the bar code visually. A bar code that is in spec has complete bars, clear spaces, and small alphanumeric characters look complete. An in spec bar code may not look as good as one that is too dark, but it has the highest scan rate.



Dark



IN SPEC

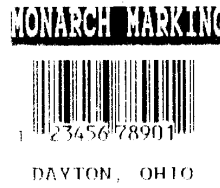

Light

Verifier

The verifier scans and checks the quality of bar codes as they are printed. The optional verifier must be purchased separately. The verifier scans parallel bar codes; it can not scan serial bar codes or read the RFID data programmed into the label.

The verifier must be enabled and set up before you can scan bar codes. For set up procedures, refer to your verifier's *Operating Instructions* available on our Web site.

To enable the verifier, from the Main Menu, select Setup, then Verifier. Then follow these steps.

1. Press ← or → until you see



A rectangular box containing the text 'VERIFIER' on the top line and '← State' on the bottom line.

2. Press **Enter/Pause**. The current setting is displayed, for example:



A rectangular box containing the text 'VERIFIER' on the top line and 'Disabled →' on the bottom line.

3. Press ← or → to see the other option. After you display the option you want, press **Enter/Pause**. Press **Escape/Clear** until you see the Main Menu.

SETTING COMMUNICATIONS

5

This chapter tells you how to set the serial or parallel communication values. These values provide the link for normal online printing.

Main Menu

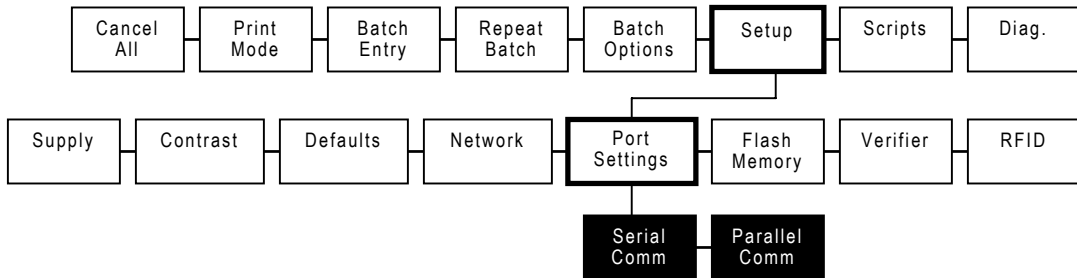

You need to set your Serial Comm values to match your computer's online communications. Before entering the communication values, see your System Administrator.

The serial communication values are listed in the table below.

Option	Choices	Default
Baud rate	1200/2400/4800/9600/19200/ 38400/57600/115200	9600
Word length	7/8	8
Stop bits	1/2	1
Parity	None/Odd/Even	None
Flow control	None/Xon/Xoff/DTR/CTS	DTR
Reset	No/Yes	No

Baud Rate

To change the setting, from the Main Menu select Setup, Port Settings, then Serial Comm. If password protection is enabled, press **Feed/Cut** three times, then press **Enter/Pause** before you see the Setup Menu options. Then, follow these steps.

1. Press **←** or **→** until you see

SERIAL COMM Baud Rate →

2. Press **Enter/Pause**. The current setting is displayed, for example:

← BAUD RATE 9600 →

Press **←** or **→** to display the baud rate you need, then press **Enter/Pause**. Press **Escape/Clear** until you see the Main Menu.

Word Length

To change the setting, from the Main Menu select Setup, Port Settings, then Serial Comm. Then, follow these steps.

1. Press **←** or **→** until you see

SERIAL COMM ← Word Length →
--

2. Press **Enter/Pause**. The current setting is displayed, for example:

← WORD LENGTH 8

3. Press **←** or **→** to display the word length you need, then press **Enter/Pause**. Press **Escape/Clear** until you see the Main Menu.

Stop Bits

To change the setting, from the Main Menu select Setup, Port Settings, then Serial Comm. Then, follow these steps.

1. Press ← or → until you see

SERIAL COMM		
←	Stopbits	→

2. Press **Enter/Pause**. The current setting is displayed, for example:

STOPBITS		
	1	→

3. Press ← or → to display the number of stop bits you need, then press **Enter/Pause**. Press **Escape/Clear** until you see the Main Menu.

Parity

To change the setting, from the Main Menu select Setup, Port Settings, then Serial Comm. Then, follow these steps.

1. Press ← or → until you see

SERIAL COMM		
←	Parity	→

2. Press **Enter/Pause**. The current setting is displayed, for example:

PARITY		
	None	→

3. Press ← or → to display the parity you need, then press **Enter/Pause**. Press **Escape/Clear** until you see the Main Menu.

Flow Control

To change the setting, from the Main Menu select Setup, Port Settings, then Serial Comm. Then, follow these steps.

1. Press ← or → until you see

```
SERIAL COMM
← Flow Control →
```

2. Press **Enter/Pause**. The current setting is displayed, for example:

```
FLOW CONTROL
← DTR →
```

3. Press ← or → to display the flow control you need, then press **Enter/Pause**. Press **Escape/Clear** until you see the Main Menu.

XON is 17; XOFF is 19. Set flow control to DTR for PC computers (unless you have XON/XOFF software).

Reset to Default Values

To change the setting, from the Main Menu select Setup, Port Settings, then Serial Comm. Then, follow these steps.

1. Press → until you see

```
SERIAL COMM
← Reset
```

2. Press **Enter/Pause**.

```
Are you sure?
No →
```

3. Press ← or → to make your selection, then press **Enter/Pause**. If you select "Yes," the following defaults are restored: 9600 baud, No parity, 8 bit word length, and 1 stop bit. Press **Escape/Clear** until you see the Main Menu.

Parallel Communications

The parallel communications menu allows you to set the values for the active parallel port. The values are listed in the table below.

Note: Turn the printer off and back on when you change the port or mode settings.

Option	Choices	Default
Port	External/Internal	External
Mode	Compatible/IEEE-1284	Compatible (Centronics mode)

Port

To change the setting, from the Main Menu select Setup, Port Settings, then Parallel Comm. Then, follow these steps.

1. Press **←** or **→** until you see

```
PARALLEL COMM
Port           →
```

2. Press **Enter/Pause**.

```
PORT
External      →
```

3. Use **←** or **→** to select either "External" or "Internal." Press **Enter/Pause**. The internal port is used for printer options installed inside the printer, such as the Ethernet communication port. The external port is used to connect a printer cable or external device directly to the parallel port.
4. Press **Escape/Clear** until you see the Main Menu.

Mode

To change the setting, from the Main Menu select Setup, Port Settings, then Parallel Comm. Then, follow these steps.

1. Press ← or → until you see

PARALLEL COMM ← Mode

2. Press **Enter/Pause**.

MODE Compatible →

3. Use ← or → to select either "Compatible" or "IEEE1284." Press **Enter/Pause**. Use compatible mode for a computer connection to the printer with a parallel cable. Use IEEE-1284 for bi-directional Ethernet communications. See Appendix B, "Accessories and Options" for more information about Ethernet options.
4. Press **Escape/Clear** until you see the Main Menu.

SETTING DEFAULTS

6

This chapter explains how to select the monetary sign, secondary sign, decimal places, slashed zero, power-up mode, prompt set, imaging errors, and ignore configuration packets. This chapter also explains how to format flash, check the available flash memory, and pack flash memory.

Main Menu

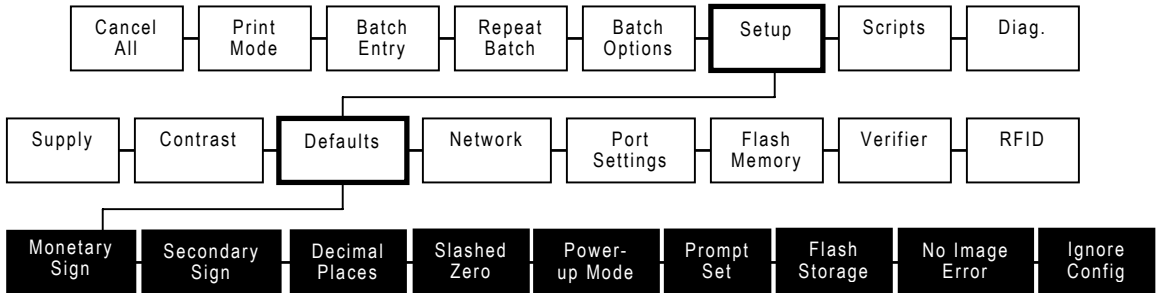

You can set your printer configurations to fit your daily operation, using either the offline menus or the online configuration option. After an option is selected in the online configuration or offline Setup Menu, the option is saved when the printer is turned off.

The monetary formatting options are listed in the table below.

Option	Choices	Default
Monetary sign	None/USA/UK/Japan/ Germany/France/Spain/ Italy/Sweden/Finland/ Austria/India/Russia/ Korea/Thailand/China/Euro-Dollar	USA
Secondary Sign	No/Yes	No
Decimal Places	0/1/2/3	2
Slashed Zero	No/Yes	No
Power-up Mode	Online/Offline	Online
Prompt Set	English/French/German/ Spanish-ES/Japanese/Portuguese/ Italian/Swedish/Spanish 2/ Danish/Dutch/Finnish/Norwegian	English
Flash Storage	Disabled/Enabled	Disabled
No Image Errors	Disabled/Enabled	Disabled
Ignore Config	Disabled/Enabled	Disabled

The monetary sign, secondary sign, and decimal places options are used in conjunction with option **42**. Refer to the optional *Packet Reference Manual* for more information.

Note: The settings for Monetary Sign, Secondary Sign, Slashed Zero, and Decimal Places are applied when a format is downloaded. Changing the settings does **not** affect batches already in the printer.

Monetary Sign

You can also select **None** if you do not want a monetary sign to print in price fields. The monetary signs available for 15 countries are shown in the table below.

Country	Currency	Description
USA	\$	dollar
UK	£	pound
Japan	¥	yen
Germany	₹	deutsche mark
France	F	franc
Spain	P	peseta
Italy	L.	lira
Sweden	Kr	krona
Finland	₤	markka
Austria	₯	schilling
India	Rs	rupee
Russia	₠	ruble
Korea	₩	won
Thailand	฿	baht
China	¥	yuan
Euro-Dollar	€	euro-dollar

To change the setting, from the Main Menu, select Setup, then Defaults. If password protection is enabled, press **Feed/Cut** three times, then press **Enter/Pause** before you see the Setup Menu options. Then, follow these steps. To exit an option without changing the setting, press **Escape/Clear**.

1. Press ← or → until you see

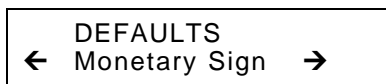

2. Press **Enter/Pause**. The current setting is displayed, for example:

MONETARY SIGN		
←	USA	→

3. Press **←** or **→** until you see the country's monetary sign you want.
4. Press **Enter/Pause**. Press **Escape/Clear** until you see the Main menu.

Secondary Sign

If you select USA as the monetary sign, you can print amounts less than \$1.00 either by using a dollar sign and decimal (\$0.30) or by using a cent sign (30¢).

- ◆ If you set the secondary sign option to **No**, prices under \$1.00 will print like this: **\$.45**
- ◆ If you set the secondary sign option to **Yes**, prices under \$1.00 will print like this: **45¢**

The same option applies to the appropriate secondary sign for monetary signs other than USA.

To change the setting, from the Main Menu, select Setup, then Defaults. Then, follow these steps.

1. Press **←** or **→** until you see

DEFAULTS		
←	Secondary Sign	→

2. Press **Enter/Pause**. The current setting is displayed, for example:

SECONDARY SIGN		
	No	→

3. Press **←** or **→** until you see the option you want. Then press **Enter/Pause**. Press **Escape/Clear** until you see the Main menu.

Decimal Places

You can set the printer for 0, 1, 2, or 3 places after the decimal in a price field. In U.S. currency, you might print prices like this: \$24.00 (**2** decimal places) or like this: \$24 (**0** decimal places).

1. Press **←** or **→** until you see

```
DEFAULTS
←  Decimal Places  →
```

2. Press **Enter/Pause**. The current setting is displayed, for example:

```
DECIMAL PLACES
←  2                →
```

3. Press **←** or **→** until you see the option you want. Then press **Enter/Pause**. Press **Escape/Clear** until you see the Main menu.

Slashed Zero

The slashed zero feature lets you select how you want the zero character printed; either without a slash, 0 or, with a slash, Ø.

Standard or reduced fonts print the slashed zero character (Ø). Bold and OCR fonts print the standard zero (0) only. The slashed zero selection will **not** be in effect until the format is sent to the printer again. If you change the way zero is printed, you must resend your formats.

To change the setting, from the Main Menu, select Setup, then Defaults. Then, follow these steps.

1. Press **←** or **→** until you see

```
DEFAULTS
←  Slashed Zero  →
```

2. Press **Enter/Pause**. The current setting is displayed, for example:

```
SLASHED ZERO
No                →
```

3. Press **←** or **→** until you see the option you want. Then press **Enter/Pause**. Press **Escape/Clear** until you see the Main Menu.

Power-Up Mode

Power-up mode lets you decide how your printer starts each time you turn it on. If you want the printer to be ready to start printing when it is turned on, use the Online power-up mode. If you want the operator to perform some other task first, use the Offline power-up mode.

To change the setting, from the Main Menu, select Setup, then Defaults. Then, follow these steps.

1. Press **←** or **→** until you see

```

  DEFAULTS
←  Powerup Mode  →

```

2. Press **Enter/Pause**. The current setting is displayed, for example:

```

  POWER UP MODE
  Online      →

```

3. Press **←** or **→** until you see the option you want. Then press **Enter/Pause**. Press **Escape/Clear** until you see the Main menu.

Prompt Set

Prompt set determines which language displays on the printer's menu. You can select English, French, German, Spanish-ES, Japanese, Portuguese, Italian, Swedish, Spanish 2, Danish, Dutch, Finnish, and Norwegian. Some prompts may remain in English, even if you select a different language.

To change the setting, from the Main Menu, select Setup, then Defaults. Then, follow these steps.

1. Press **→** until you see

```

  DEFAULTS
←  Prompt Set    →

```

2. Press **Enter/Pause**. The current setting is displayed, for example:

```

  PROMPT SET
  English    →

```

3. Press **←** or **→** until you see the option you want. Then press **Enter/Pause**. Press **Escape/Clear** until you see the Main menu.

Note: This option only affects the displayed prompts. It does not change what is printed by the printer.

Flash Storage

Flash storage allows packets (with "R" or "N" selectors) to be stored in flash memory, instead of volatile RAM. Packets stored in flash memory are saved when the printer is turned off. However, flash memory storage is limited.

Note: You must format flash memory before enabling this option. Formatting flash memory is only required once during initial printer setup.

To change the setting, from the Main Menu, select Setup, then Defaults. Then, follow these steps.

1. Press **→** until you see

DEFAULTS ← Flash Storage

2. Press **Enter/Pause**. The current setting is displayed, for example:

FLASH STORAGE Disabled →

3. Press **←** or **→** until you see the option you want. Then press **Enter/Pause**. Press **Escape/Clear** until you see the Main menu.

No Image Errors

With version 5.2 or greater software, you can disable image error reporting. Image errors occur when there is a problem producing a complete label. You must press **Escape/Clear** to clear an image error.

Image errors include

600	unable to image batch	614	portion of field off label
601	problem during imaging	615	invalid PDF417 bar code data
603	missing batch	618	invalid font size
611	invalid font, bar code or density	620	missing font data
612	missing batch data	621	invalid downloaded font
613	reference point off label	622	not enough font memory

Note: With this option enabled, the format may not print as expected and no error is reported. For example, bar codes require a non-print zone and if a bar code is placed too close to the edge of the label, no error is reported and the bar code may not scan properly.

Error 616 (bar code dot shifting failed) is always reported.

To change the setting, from the Main Menu, select **Setup**, then **Defaults**. Then, follow these steps.

1. Press **←** or **→** until you see

```

  DEFAULTS
  ← No Image Error →

```

2. Press **Enter/Pause**. The current setting is displayed, for example:

```

  NO IMAGE ERRORS
  Disabled      →

```

3. Press **←** or **→** until you see the option you need. Then press **Enter/Pause**.
4. Press **Escape/Clear** until you see the Main Menu.

Ignore Configuration

With version 5.2 or greater software, you can ignore all online configuration packets. If the printer receives data from a host system or software package that includes online configuration packets with the format, those online configuration packets can be ignored. Ignoring these packets is useful when you cannot change your host's data or when you want the printer to operate as specified through the printer's menu.

Note: We recommend changing your host's data stream, but if that is not possible, enable this option.

Use caution if ignoring online configuration packets, because the printer may need the configuration for proper operation.

To change the setting, from the Main Menu, select **Setup**, then **Defaults**. Then, follow these steps.

1. Press **←** or **→** until you see

DEFAULTS ← Ignore Config

2. Press **Enter/Pause**. The current setting is displayed, for example:

IGNORE CONFIG Disabled →

3. Press **←** or **→** until you see the option you want. Then press **Enter/Pause**.
4. Press **Escape/Clear** until you see the Main Menu.

Using Flash Memory

The flash memory options are listed in the table below.

Option	Choices	Default
Format Flash	No/Yes	No
Unused Flash	NA	NA
Pack Flash	No/Yes	No

Formatting Flash Memory

Before storing packets in flash memory, downloading a script, or if the printer's firmware is updated, you must format the flash memory.

Formatting flash memory is only required once during initial printer setup.

Note: When you format flash memory, the script and any downloaded TrueType® fonts saved in the printer's flash memory are deleted and must be resent to the printer.

To format flash memory, from the Main Menu, select Setup. Then, follow these steps.

1. Press ← or → until you see

```
SETUP
←  Flash Memory  →
```

2. Press **Enter/Pause**.

```
FLASH MEMORY
Format Flash  →
```

3. Press **Enter/Pause**.

Are you sure?
No →

4. Press → to display "Yes" and press **Enter/Pause**.

CREATING FLASH
FILE SYSTEM 1

The printer's flash memory is cleared and reformatted. *This process may take several minutes.* The printer reboots automatically after formatting flash memory. You need to resend any fonts you want to use to flash memory again. You return to the "Print Mode Ready" menu.

Checking Available Flash Memory

If you receive errors when downloading a script or other packets, make sure you have enough flash memory available.

Note: When you format flash memory, the script and any downloaded TrueType fonts saved in the printer's flash memory are deleted and must be resent to the printer.

To check available flash memory, from the Main Menu, select Setup. Then, follow these steps.

1. Press ← or → until you see

SETUP
← Flash Memory →

2. Press **Enter/Pause**.
3. Press ← or → until you see

FLASH MEMORY
← Unused Flash →

4. Press **Enter/Pause**. You see the number (in bytes) of available flash memory.

Unused Flash
← 1006216_

5. Press **Escape/Clear** until you see the Main menu.

Packing Flash Memory

Packing flash memory permanently removes any deleted files from memory. Periodically select this option to "clean up" the printer's memory. Any deleted files are removed from memory when you pack flash.

To pack flash memory, from the Main Menu, select Setup. Then, follow these steps.

1. Press **←** or **→** until you see

```
  SETUP
  ←  Flash Memory  →
```

2. Press **Enter/Pause**. Press **←** or **→** until you see

```
  FLASH MEMORY
  ←  Pack Flash
```

3. Press **Enter/Pause**.

```
  Are you sure?
  No           →
```

4. Press **→** to display "Yes" and press **Enter/Pause**.

All the deleted files in flash memory are permanently erased.

5. Press **Escape/Clear** until you see the Main menu.

Memory Guidelines

Use these basic guidelines when storing files in your printer's memory.

- ◆ Your printer may have volatile RAM (packets deleted when the printer is turned off), non-volatile RAM (packets saved when the printer is turned off), and flash memory (packets saved when the printer is turned off). Each printer has a different limit of available memory.
- ◆ Before you save any packets in flash memory, you must format flash memory first. See "Formatting Flash Memory" for more information.
- ◆ Formats, graphics, and check digits can be saved in flash (but they are also duplicated in RAM). Any packets saved in flash cannot exceed the memory available in RAM.
- ◆ Fonts are stored differently in flash. If you print TrueType or double-byte Asian fonts, use a 9855 or 9860 printer with the extended memory option.
- ◆ There is not a 1-to-1 ratio between the memory in your printer and the memory in your PC. For example, a file that is 5K in Windows may require 15-20K to store in your printer.
- ◆ When using graphics, use the lowest-resolution graphic possible. If your printer uses a 203 dpi printhead, the graphic's resolution should be 150 to 200 dpi. In fact, 96 dpi may work. Try to create the smallest file size possible.
- ◆ Use temporary storage for graphics that are only used once or twice. However, if you have a logo that is used on multiple formats, save the graphic in flash. Once again, try to create the smallest file size possible for your graphic.
- ◆ Each line in a packet requires the same amount of memory. The smaller the format, the less memory required to save it.

Setting Batch Options

You can select Batch Options to change, which prompts appear during Batch Entry mode and set default values for those prompts. Customizing which prompts appear during batch entry can reduce the time it takes to enter data for a format. If the optional knife is not installed, you can prevent those prompts from appearing during batch entry mode. If you set a new default value for an option, that value is used even if the prompt is not displayed. If you do not change a default value for an option, the system default is used if the prompt is not displayed.

Note: Setting batch options requires the optional keypad, which must be purchased separately.

Refer to your keyboard's *Operating Instructions* for more information.

Setting Up the Network Printer

Your System Administrator should refer to the *MonarchNet2™ Operating Instructions* (available on our Web site) for more information about your network printer.

Setting Up the RFID Printer

Your System Administrator should refer to the *Multi-Protocol Application Notes* or the *HF Application Notes* (available on our Web site) for more information about setting up your RFID printer.

USING SCRIPTS

7

This chapter explains how to load, enable, and delete scripts. You can also enable status polling and immediate commands.

Using the Scripts menu requires custom software from Paxar. It allows you to print data streams written for other printers.

Note: Ignore these menus if you do not use Scripts.

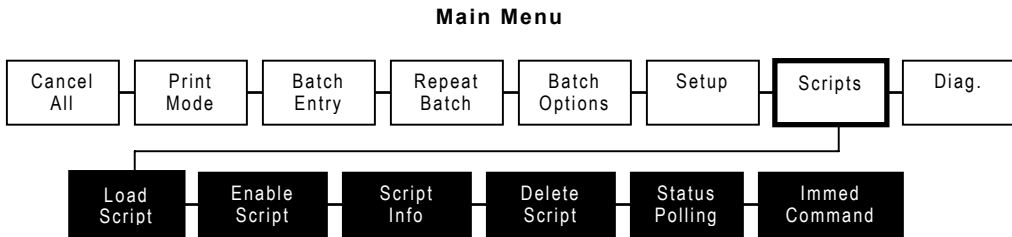

Your System Administrator may limit access to this menu to prevent supply, network, script, or communication settings from being changed. If password protection is turned on, you see

Enter Password

when you try to access the scripts menu. Get the password from your System Administrator to continue.

Initial Script Startup Procedures

Before you can start using a script, check the following items:

- ◆ Check to see if a script is already loaded in the printer. See "Viewing Script Information" to continue.
- ◆ Format flash memory, if needed. See "Formatting Flash Memory" in Chapter 6 for more information.
- ◆ Download a script to the printer, if needed. See "Downloading a Script" to continue.

Viewing Script Information

1. To see if your printer has a script loaded from the Main menu, press ← or → until you see

MAIN MENU
← Scripts →

2. Press **Enter/Pause**. If password protection is enabled, press **Feed/Cut** three times, then press **Enter/Pause** before you see the Scripts Menu options.
3. Press ← or → until you see

SCRIPTS
← Script Info →

4. Press **Enter/Pause**. What you see depends on the script. If a script is not loaded, you see "No script loaded." If a script is loaded, you see the script name and version number, for example,

MYSTORE
Version 1.0

If a script is already loaded, see "Enabling a Script," to continue. If you need to download a script, see "Formatting Flash Memory" in Chapter 6.

Downloading a Script

Follow these instructions to download a script from the MS DOS prompt. Set the communication parameters using the MODE command. Then, prepare the printer to accept a script.

1. From the printer's Script Menu, press ← or → until you see

SCRIPTS Load Script →

2. Press **Enter/Pause**.

Script Load Ready

Note: Only one script can be loaded in the printer at a time.

When downloading a script, if you receive an error:

- ◆ Check the available flash memory. See "Checking Available Flash Memory" in Chapter 6 for more information.
- ◆ Format flash memory. See "Formatting Flash Memory" in Chapter 6 for more information.

After downloading a script, if the script does not appear to be loaded, try formatting flash memory and download the script again.

Enabling a Script

The script must be enabled before you can use it.

To enable or disable a script:

1. From the Script Menu, press ← or → until you see

SCRIPTS ← Enable Script →

2. Press **Enter/Pause**.

Enable Script? ← Yes

3. Use ← or → to select either "Yes" or "No" and press **Enter/Pause**.
Selecting "Yes" starts the script. Selecting "No" stops the script. If you select "Yes," when you turn off the printer and turn it back on, the script automatically starts.

Once the script is enabled, you will see

Print Mode S Ready

The "S" in the lower left-hand corner of the screen indicates the printer has a script loaded and enabled (the script is running).

Deleting a Script

You can delete a script from the printer's memory.

To delete a script:

1. From the Script Menu, press ← or → until you see

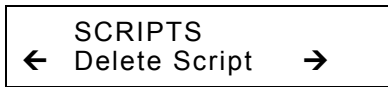

2. Press **Enter/Pause**.

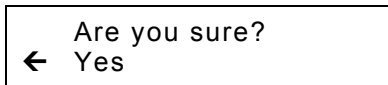

3. Use ← or → to select either "Yes" or "No" and press **Enter/Pause**.
Selecting "Yes" deletes the current script.

Note: The flash memory used by the script is not available for other scripts or fonts until the flash memory is reformatted. However, when you format flash memory, you must resend the script and any downloaded fonts to the printer.

4. Press **Escape/Clear** until you see the Main Menu.

Enabling Status Polling

Status polling allows you to obtain information about the readiness of the printer and the current (or last received) print job. Your System Administrator can enable status polling while the printer is running in Script mode. To enable status polling:

1. From the Script Menu, press ← or → until you see

SCRIPTS ←Status Polling →

2. Press **Enter/Pause**.

Enable Polling No →

3. Use ← or → to select either "Yes" or "No" and press **Enter/Pause**. The default is "No."

Using Immediate Commands

Your System Administrator can use immediate commands to reset the printer or cancel and repeat batches. Immediate commands are turned on or off through an MPCL packet. Your System Administration should refer to the *Packet Reference Manual* (available on our Web site) for more information about immediate commands and control characters.

Use this option to set whether the ADK script processes or ignores an immediate command control character.

To enable the ADK script to process immediate commands:

1. From the Script Menu, press ← or → until you see

```
SCRIPTS
← Immed Commands
```

2. Press **Enter/Pause**.

```
Enable Immed?
← Yes
```

3. Use ← or → to select either "Yes" or "No" and press **Enter/Pause**. The default is "No."

Selecting "Yes" allows the immediate command control character to be processed by the printer and performs the requested immediate command.

Selecting "No" prevents the script and printer from processing the immediate command control character. Instead, the immediate command control character and immediate command are treated as data.

4. Press **Escape/Clear** until you see the Main Menu.

This chapter explains how to

- ◆ use on-demand mode printing.
- ◆ print an error label.
- ◆ print, pause, restart, cancel, and repeat a batch.

You can send format, batch, and graphic data to the printer from a host. When the printer receives the data, batches begin printing automatically. The optional *Packet Reference Manual* tells how to create, store, and download the data necessary to print batches. You can also use the Monarch® MPCL™ Toolbox utilities to create and download packets.

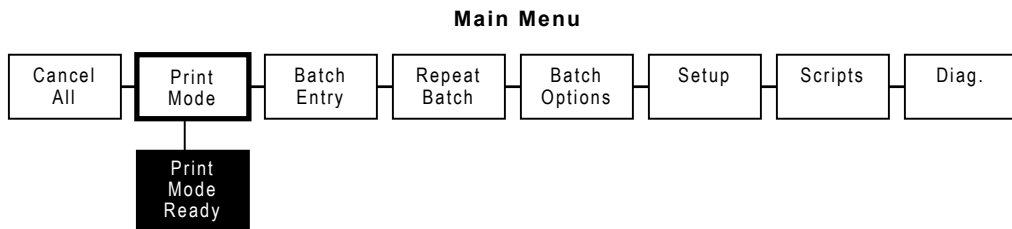

Printing

Before you print, make sure the printer is connected and ready to receive data.

- 1.** Turn on the printer. Your printer is ready to receive and print batches when you see "PRINT MODE Ready."
- 2.** Download a format and a batch. Refer to the optional *Packet Reference Manual* for information on downloading print jobs.
- 3.** The printer prints a strip of labels. If printing RFID supplies, you see "RFID Printing..."
- 4.** Remove the printed labels.

The RFID printer pauses while programming the RFID tag.

If the RFID tag is not programmable for any reason, the supply may print with an overstrike pattern, indicating that it should not be used. Your System Administrator should set the desired Error Action accordingly. See Chapter 4, "Setting Supply Options" for more information about the error action modes.

When printing on non-RFID supplies, you may also see a label with an overstrike pattern. Do not use that label.

Note: If the printer will be unused for extended periods of time, we recommend leaving the printhead unlatched.

An optional keyboard is also available to enter offline batch data. The keyboard must be purchased separately. If there are offline batches in the print queue, the offline batches print after the downloaded batches have printed.

On-Demand Mode Printing

When this printer is operating in the on-demand mode, the next label prints when the previous label is removed from the printer or when **Feed/Cut** is pressed. The display shows "Printing X of Y" until all the labels in the batch are printed.

If you have purchased the optional peel module, you must use on-demand printing with peel mode. If you are using peel mode, remove the excess backing paper by pulling up across the saw-toothed tear edge. Make sure the backing paper tears at the edge. Hold the leading edge of peeled labels when printing on stock longer than six inches. The minimum feed length for peel mode is 1.5 inches. You must use non-perforated supplies for peel mode. The maximum speed for peel mode is 8.0 ips.

Note: We recommend using 0.5-inch gap supplies in peel mode when backfeed is disabled.

Printing an Error Label

If the printer displays a data error (errors 0-499), press **Feed** to print an error label and continue printing. See your System Administrator about the error label.

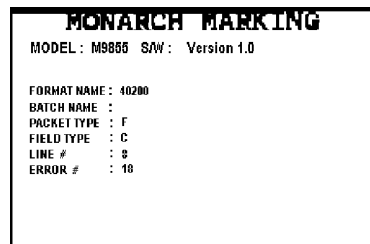

Pausing a Batch

You can pause printing by pressing **Enter/Pause**. You may want to interrupt a batch to make adjustments for:

- ◆ Loading a different roll of supply or a ribbon. See Chapter 2, "Loading Supplies" or Chapter 3, "Loading Ribbon" for more information.
- ◆ Adjusting the supply position or contrast using the Setup menu. See Chapter 4, "Setting Supply Options" for more information.

When you press **Enter/Pause** you will see



You can press **Enter/Pause** to resume printing or press ← or → to display the Pause Menu options.

The following chart shows the Pause Menu options.

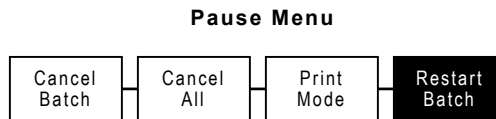

Restarting a Batch

You can reprint a paused batch from the beginning (using the original quantity).

1. When you press **Enter/Pause**, you will see



2. Press ← or → until you see



3. Press **Enter/Pause**. The batch starts printing from the beginning.

Canceling a Paused Batch

You can cancel a paused batch, delete a format, graphic, or font in memory, or all the batches waiting to print.

Note: Before any format, graphic, or font in memory can be deleted, you must cancel all batches.

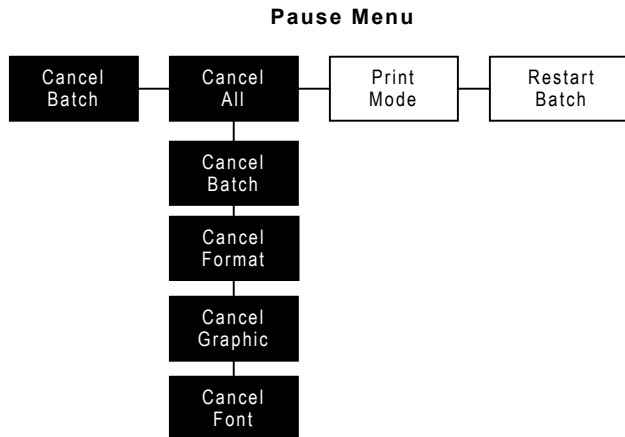

You can cancel a batch by pressing **Escape/Clear** while the batch is printing, or you can use the Pause menu to cancel a batch.

1. Press **Enter/Pause** to interrupt printing.

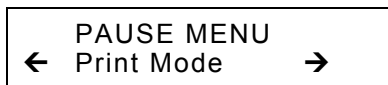

- ◆ If you want to cancel only the paused batch, skip step 3.
- ◆ If you want to cancel all the batches, skip step 2.

2. To cancel only the paused batch, press **←** or **→** until you see



Then press **Enter/Pause**. The batch is deleted and the printer prints any remaining batches.

3. To cancel all the batches (including the paused batch), press ← or → until you see

```
PAUSE MENU
← Cancel All →
```

and press **Enter/Pause**.

```
Cancel Batches?
No →
```

4. You can
- ◆ exit without canceling any batches. Press **Escape/Clear** or press → to display **No** and then press **Enter/Pause**. The printer returns to the Pause menu. Press ← or → to select another function from the Pause Menu, or to return to Print Mode and print all the batches.
 - ◆ cancel all batches in the print queue. Press → to display **Yes**, then press **Enter/Pause**.

```
Cancel Format?
No →
```

Press ← or → then press **Enter/Pause**.

If password protection is enabled, you are prompted to enter a password before the formats, graphics, and fonts are deleted. Press **Feed/Cut** three times and then press **Enter/Pause**.

All formats are deleted. If you enter the wrong password, you return to the Main menu. For more information about password protection, see "Using Password Protection" in Chapter 10. If password protection is disabled, you will see

```
Cancel Graphic?
No →
```

Press ← or → then press **Enter/Pause**.

```
Cancel Font?
No →
```

Press →, then press **Enter/Pause**. You return to the Pause menu. If you select "Yes," these prompts delete ALL formats, graphics, and/or fonts in the printer.

5. Press ← or → to select another function from the Pause menu, or to return to Print mode.

Repeating a Batch

Before you start printing a new batch, you can reprint the last batch. The batch can be either the last one you printed completely or one that you canceled after starting to print.

1. From the Main Menu, press ← or → until you see

```
MAIN MENU
← Repeat Batch →
```

2. Press **Enter/Pause**.

```
Printing
xxxx of xxxx
```

The number increments until the entire batch has printed. When it is finished, you will see

```
PRINT MODE
Ready
```

Offline Printing

Offline printing requires the optional keyboard, which must be purchased separately. Refer to your keyboard's *Operating Instructions* for more information about offline printing and batch entry.

Special Printing Considerations

Keep in mind the following special printing considerations.

Maximum Print Speed	Printing Method	Printhead Density	Knife	Peel Mode
2.5/4.0/6.0 ips (inches per second)	Thermal Direct Thermal Transfer	203/300 dpi dots per inch	Supported	Supported
8.0 ips	Thermal Direct Thermal Transfer	203/300 dpi	Not Supported	Supported
10.0 ips	Thermal Direct/Thermal Transfer	203 dpi only	Not Supported	Not Supported

- ◆ The minimum label feed length is 0.75 inches (19 mm) using 8.0 ips or higher.
- ◆ 94x5 emulation is not supported using 300 dpi.
- ◆ The maximum supply and image length with the optional 300 dpi printhead is 12.0 inches (305 mm).
- ◆ You may need to clean the printhead and platen roller more frequently when printing at high speeds. See Chapter 9, "Care and Maintenance," for more information.

Printing TrueType® Fonts

TrueType® fonts are available on this printer. TrueType fonts are scalable and the characters print smoothly, without the jagged edges you see on bitmap fonts. When downloading a TrueType font, you download the entire font. You cannot specify a subset (particular characters or point size) of the font.

Note: These font files may be very large and image slower than bitmap fonts. The size of the font file, in bytes, is the minimum amount of memory you must have available for fonts in the printer's memory.

Your System Administrator may need to reconfigure the printer's memory to use downloaded TrueType fonts. Refer to the optional *Packet Reference Manual* (available on our Web site) to learn how to reconfigure the printer's memory. After reconfiguring memory, resend the font, format, and batch packets.

This printer can accept a TrueType font file that has been converted to Hex or Run-Length encoding using the version of Font Utility. Font Utility is available on our Web site (www.paxar.com). Font Utility is a part of the Monarch MPCL Toolbox Utilities. You can also use a wide variety of Code Pages with International (Turkish, Latin, Spanish, etc.) characters. Using TrueType fonts allows you a greater range of fonts for your formats. TrueType fonts are designed to be regionally specific; therefore, all Code Pages may not be supported in a given font. Check with your System Administrator if you need to use TrueType fonts.

Licensing Your Fonts

We provide the Font Utility to help you create and download international code pages/characters. However, it is your responsibility to license the fonts you purchase and download to your printer. Contact your font supplier for licensing information.

Additional fonts that are compatible with this printer can be purchased from:

The Electronic Font Foundry; 11 Silwood Road; Ascot; SL5 OPY; England
(0)1344 875 201
www.fff.co.uk

This chapter tells you how to

- ◆ clear label jams and clean the printer.
- ◆ replace a printhead.

CAUTION: Do not use sharp objects to clean the printhead or touch the printhead with your fingers. This may damage the printer and require a service charge.

Label Jams

When you are printing and a jam occurs, the **Fault** light on the printer's front panel blinks. To clear the jam:

1. Turn off the printer and open the cover and printhead assembly.
2. If necessary, remove the label roll and ribbon.
3. Remove the jammed labels and reload the label roll.
4. Close the printhead assembly and turn on the printer.
5. Press **Feed/Cut** to position the supply under the printhead.

Cleaning

The rate and frequency at which you print determines how often you must clean the printer.

Note: You **must** clean the printhead as described below to maintain printhead life.

You may need to clean the printhead, sensor, and platen roller:

- ◆ if there is any adhesive build-up in the supply path.
- ◆ after printing approximately 3 rolls of thermal transfer/thermal direct/linerless supplies or after each ribbon.
- ◆ daily if your printer is in an excessively dirty, hot, or humid environment.
- ◆ when you see voids or streaking in the print as shown.



Voids



Streaks

When you are using higher speeds (with 203 or 300 dpi), and/or increased print contrast, we recommend cleaning the printhead after each ribbon with isopropyl alcohol. If you still notice build-up on the printhead or black streaks on your supply, order a printhead CLEAN-STRIP.

1. **Turn off the printer** and open the cover and printhead assembly.
2. Remove the label roll and ribbon (when cleaning the printhead).
3. Press down on the exit cover tabs to open the exit cover on the front of the printer.

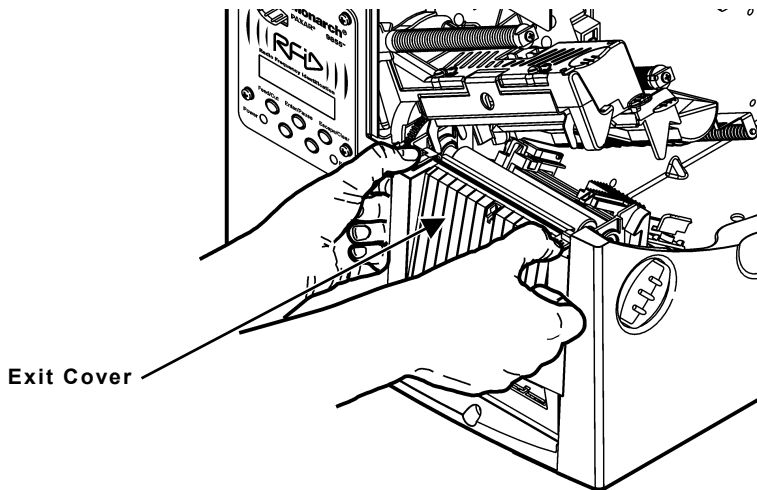

- 4.** Clean the platen roller when you see significant adhesive build-up or a label is wrapped around the platen roller. Use a dry, soft-bristle brush, such as a toothbrush, to clean the platen roller. If the brush does not remove all the adhesive, use isopropyl alcohol on the roller. Moisten a cotton swab with isopropyl alcohol and run the cotton swab across the platen roller. Turn the platen roller with your finger to make sure the platen roller is clean all the way around. After cleaning, feed several inches of supply through without printing to remove any remaining isopropyl alcohol.
- 5.** Moisten a cotton swab with isopropyl alcohol. Rub the cotton swab across the peel bar and remove any build-up.
- 6.** Moisten another cotton swab with isopropyl alcohol. Rub the cotton swab across the printhead and remove any build-up. You may need to use a printhead CLEAN-STRIP if the printhead is extremely dirty or you see streaks on the supply.

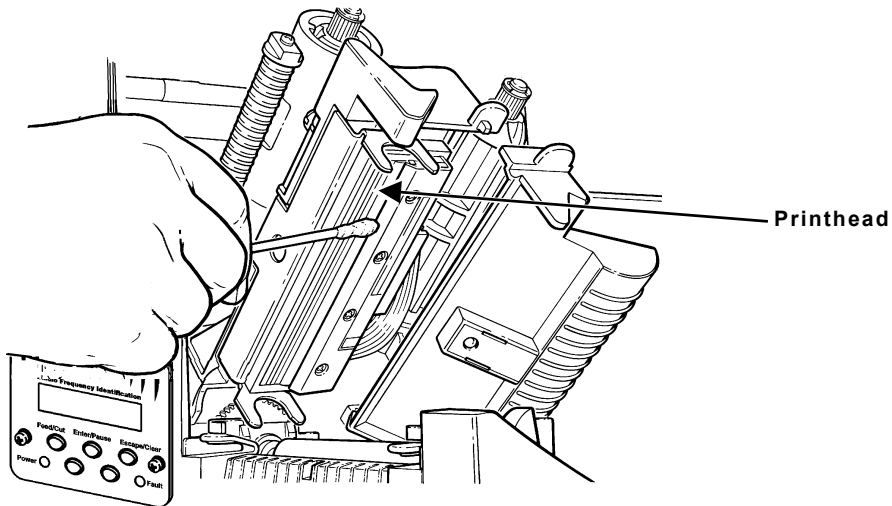

7. Rub the cotton swab across the supply sensor and die cut sensor and remove any build-up.

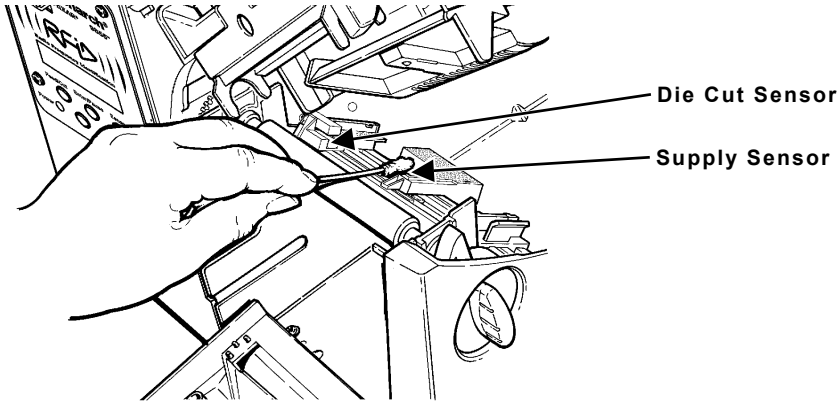

8. Clean the build-up in the supply path.
9. Let the printer dry before you reload supplies.
10. Close the exit cover by pushing firmly on it. Both latches will click into place.
11. Close the cover and printhead assembly.

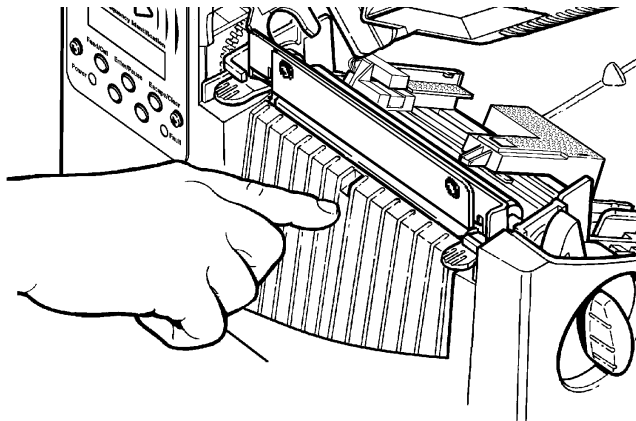

12. Turn on the printer.
13. Press **Feed/Cut** to position the supply under the printhead. Resend your format, batch, and check digit packets.

Replacing the Printhead

You may have to replace the printhead if it is damaged or worn-out. For example, you may see 616 (bad dot or dots) or 768 (printhead failure) error codes. See Appendix B, "Accessories and Options" for the printhead part number.

CAUTION: The printhead is sensitive to static electricity, which can damage the printhead or reduce its life. Ground yourself by touching some metal, such as the printer's metal base, before touching the printhead. Clean the printhead to remove any salt or oil left from handling prior to operation.

To replace the printhead:

- 1. Turn off the printer.**
- 2. Open the cover.**
- 3. Unlock the printhead by turning the retaining latch.**
- 4. Press forward and down on the two latches on top of the printhead assembly as shown. The printhead will drop down.**

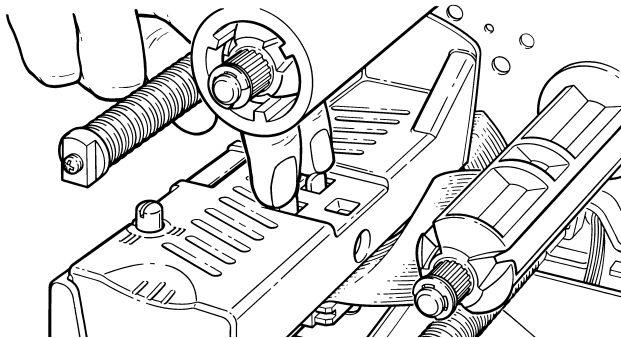

- 5. Lift the printhead assembly using the printhead tab and push back until the printhead assembly clicks into place.**

6. Carefully unplug the cable from the printhead as shown. The printhead is sensitive to static electricity, which can damage the printhead or reduce its life. Ground yourself by touching some metal, such as the printer's metal base, before touching the printhead.

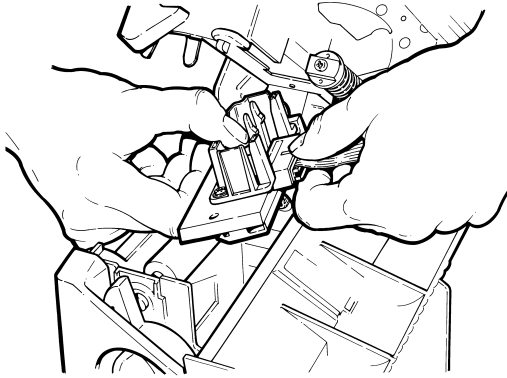

7. Carefully plug the cable into the new printhead.
8. Align the new printhead with the tabs.
9. Snap the printhead into place.

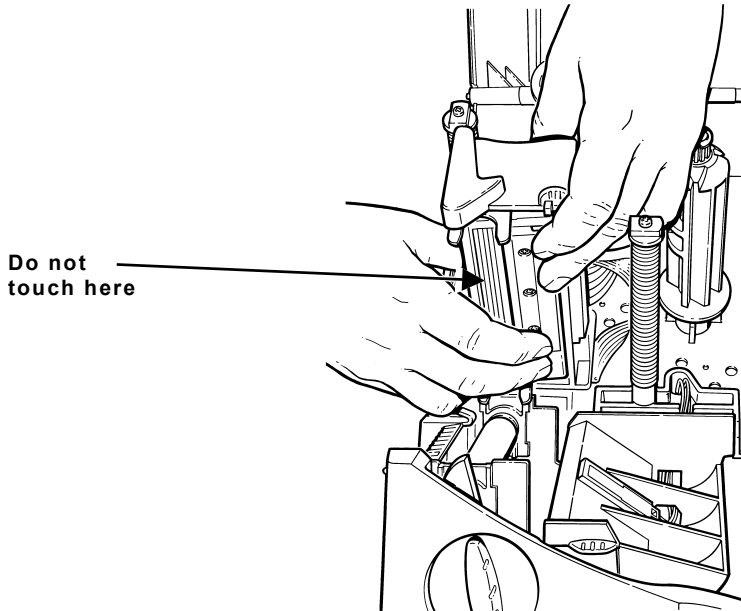

Note: Make sure the printhead cable does not touch the ribbon roll.

- 10.** Clean the new printhead with a cotton swab dipped in isopropyl alcohol to remove any salt or oil left from handling.
- 11.** Let the printhead dry and reload your supplies.
- 12.** Close the printhead assembly and the cover. Turn on the printer.
- 13.** Press **Feed/Cut** to position the supply under the printhead.

DIAGNOSTICS AND TROUBLESHOOTING

This chapter explains how to perform simple diagnostic functions such as checking the software version, the supply quality, printing test labels, and using password protection. It also contains basic troubleshooting information.

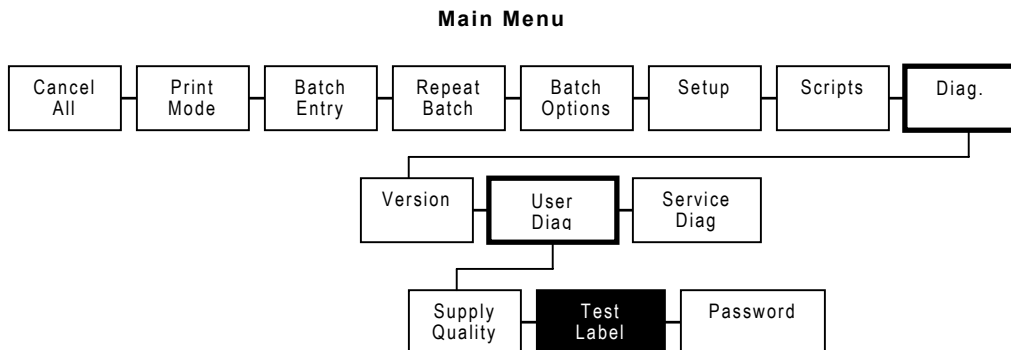

Factory Set Password

You need a password to access diagnostic functions. Press **Feed/Cut** three times and then press **Enter/Pause**.

Checking the Software Version

1. From the Diagnostics Menu, press **←** or **→** until you see

```
DIAGNOSTICS
Version      →
```

2. Press **Enter/Pause**.

```
VERSION
←  RFID Hardware  →
```

3. Use **←** or **→** to see all the options: Printer, Knife, 1284 Port, RFID Hardware, or RFID Firmware. After you display the option you want, press **Enter/Pause**.

A screen similar to this one is displayed:

Model M9855
931110841

The RFID versions are for the antenna/board (hardware) and firmware. Your version information for Hardware and Firmware may appear different from the one shown.

4. Press **Escape/Clear** until you see the Main Menu.

Printing a Test Label

1. From the Diagnostics Menu, press **←** or **→** until you see

DIAGNOSTICS
← User Diag →

2. Press **Enter/Pause** and **→** until you see

USER DIAG
← Test Label

```
MONARCH
MODEL:M9855 S/M:Version 4.1
A,0,0,0,0,0; B,1,1,0,0,0;
C,0,0,0,0,0;
D,1,0,2;
E,{,,"",,},,--,--,0d/0a;
F,3,1,0,0,1;
G,0,65,65;
H,0,R,640; H,F,R,1280;
M,1,R,3300; H,R,R,640;
N,T,R,640; H,V,R,3340;
```

```
MONARCH
MODEL:M9855 S/M:Version 4.1
TOTAL INCHES: 0002407
HI ENERGY INCHES: 0000000
VOLTAGE: 24.0
TOTAL CUTS: 0000170
CONTRAST POT: 020
PH RESISTANCE: <0832> 0849
BAD DOTS: 000
MEMORY: 16384KR/4096KF
OPTIONS: --
```

3. Press **Enter/Pause**. The following test labels print.

The first label shows the printer's configuration by packet (A-G). The second label shows the model number, software version, stock count, voltage, print contrast, printhead resistance, number of bad dots, and installed options. The test label also shows an inch count for the high energy ribbon. This information will help Service diagnose the problem. Refer to the optional *Packet Reference Manual* for more information about the test label.

You can also print a test label by pressing **←** and **→** at the same time. Hold for one second and release. If test labels do not print, call Service.

Checking Supply Quality

The printer continuously stores data from the most recent 16 supplies printed to check the reflectivity of the sensor marks on the supply. Before you check your supply quality, print a batch of supplies or test labels.

1. From the Diagnostics menu, press ← or → until you see

DIAGNOSTICS
← User Diag →

2. Press **Enter/Pause**. You will be at the User Diagnostics menu. Press ← or → until you see

USER DIAG
Supply Quality →

3. Press **Enter/Pause**. If you have not printed any labels, the message "No data! Press Enter" appears. You will also see the "No data! Press Enter" message if you are using continuous (non-indexed) supplies. If you have printed labels since turning on the printer, you will see

Len	Min	Max	OK
← 1568	034	124	Y →

The Len listing is the length of the loaded supply in dots.

The Max listing should always be greater than the Min listing. The OK listing tells whether the sense mark on the supply passed a detection test. Press ← or → to see the other readings.

Using Password Protection

The password protection feature prevents formats, graphics or fonts from accidentally being deleted from the printer's memory. *It also limits access to the Setup and Scripts menus.*

Enabling the Password (System Administrators only)

A System Administrator can enable the password that must be entered before formats, graphics or fonts can be deleted.

1. From the Main Menu, press ← or → until you see

```
MAIN MENU
← Diagnostics
```

2. Press **Enter/Pause**. You will see

```
Enter Password
-----
```

3. Enter the password: press **Feed/Cut** three times and then press **Enter/Pause**.
If you enter the wrong password, you return to the Main Menu.

4. From the Diagnostics Menu, press ← or → until you see

```
DIAGNOSTICS
← User Diag
```

5. Press **Enter/Pause**. Then, press ← or → until you see

```
USER DIAG
← Password
```

6. Press **Enter/Pause**. You will see

```
Enable Password?
← No
```

The default for password protection is "No," so you will always see "No" even if passwords are enabled.

7. If you do not want the user to enter a password before they can delete formats, graphics, fonts, or access to the Setup and Scripts menus, press **Enter/Pause**. You return to the User Diagnostics Menu.

OR

Press **→** to display "Yes" and press **Enter/Pause**. The password protection is enabled for formats, graphics, fonts, and access to the Setup and Scripts menus. You return to the User Diagnostics Menu.

8. Press **Escape/Clear** twice to exit to the Main Menu.

Note: When password protection is enabled, a password is not required to clear batches, but it is needed to clear formats, graphics, and fonts.

Service Diagnostics

The Service Diagnostics menu can only be accessed by a Paxar Representative, because it requires a separate password. If you need to call Service, print a test label first.

Troubleshooting

This section helps you correct some problems that may occur.

Problem	Action
Error message appears during startup.	Turn off the printer. Wait fifteen seconds and then turn on the printer. Call Service if the error message reappears.
Does not print.	Check supply. Check ribbon. Send a corrected format and batch packet.
Does not feed.	Set wide/narrow knobs correctly.
Partially printed data.	Clean the printhead. Send a corrected format packet.
Printing shadows or smears.	Clean the printhead. Change supply. Check ribbon.
Light printing.	Change supply. Adjust the print contrast. Check wide/narrow knobs. Check ribbon.
Heavy printing.	Clean the printhead. Change supply. Adjust the print contrast. Check wide/narrow knobs. Check ribbon.
Voids in printing.	Clean the printhead. Change supply type. Check ribbon.
Serial bar codes do not print.	Leave printhead unlatched when not in use. Use a print speed of 2.5 IPS. Adjust the print contrast.

Problem	Action
Backing paper is wrapped around platen or peel roller.	Carefully remove the backing paper. Make sure the backing paper tears at the saw-toothed tear edge when using backfeed and peel mode.
Blank labels print or 750 series errors.	Clean supply sensors.
When downloading a script, the printer errors.	Check the available flash memory. Format flash memory or clear NVRAM.
After downloading a script, the script does not appear to be loaded.	Try formatting flash memory, then download the script again.
Printer displays "Please Wait RFID Initialization."	You sent an RFID batch before the printer communicated with the interrogator. The printer prints the RFID batch once communication with the interrogator is complete.
Printer displays "RFID Detection Not Complete."	You tried to access the Setup, RFID Menu before the printer communicated with the interrogator. Press Escape/Clear until you see "Print Mode Ready." Wait several seconds and then try to access the Setup, RFID Menu again.
Printer displays "Monarch Initializing."	This message should flash briefly on the display when you turn on the RFID printer. If it does not disappear, turn off the printer; wait fifteen seconds and then turn on the printer.
Printer does not read or program the RFID tag.	Make sure the following are set correctly for your inlay (RFID tag) type: Protocol (C1Gen1, EM4122, etc.), Read Power, Write Power, and Signal Adjust. Refer to your <i>RFID Setup Guide & Supply Chart</i> or the <i>HF Setup Guide & Supply Chart</i> for more information. The EM4122 protocol requires Option 5 to read the pre-programmed RFID data. Refer to the <i>Packet Reference Manual</i> for more information.

If you cannot fix a problem, call Service.

Error Messages

You may receive the following types of error messages:

- ◆ Data Errors
- ◆ Communication Errors

Some errors numbered 400-438 and 500-574 are internal software errors. Errors numbered 900-999 are hard printer failures. If you cannot clear an error, turn off the printer, wait several seconds and then turn on the printer. For a complete list of errors, refer to the *Packet Reference Manual* available on our Web site. Call Service if you need additional assistance.

Common Errors

Errors 001 to 405 and 429 to 435 are data errors. This type of error indicates that incorrect data was sent to the printer, and the printer is ignoring it. Your System Administrator should correct the packet and send it back to the printer.

Error	Description/Action
002	Name must be 1 to 8 characters (excluding non-printable control characters) inside quotes.
005	Supply width is invalid.
018	Code page selection defined in the field must be 0 (Internal), 1 (ANSI), 100 (Macintosh), 101 (Wingdings), 102 (UNICODE), 103 (BIG5 for UNICODE), 104 (GB2312 for UNICODE), 105 (SJIS for UNICODE), 106 (GB2312), 107 (BIG5), 437 (DOS Page 437), 850 (DOS Page 850), 852 (Latin 2), 855 (Russian), 857 (Turkish), 860 (Portuguese), 1250 (Latin 2), 1251 (Cyrillic), 1252 (Latin 1), 1253 (Greek), 1254 (Turkish), 1255 (Hebrew), 1256 (Arabic), 1257 (Baltic), or 1258 (Vietnamese).
025	Data length is too long.
052	Data type in the RFID Data Field must be 0, 1, 2, or 3. Refer to the <i>Packet Reference Manual</i> for more information.
053	The starting block in the RFID Data Field is invalid. Refer to the <i>HF (High Frequency) Application Notes</i> for more information.
101	Format referenced by batch not in memory.
228	Memory class identifier is invalid. The identifier must be A (AFI), D (DSFID), or E (EAS) for Option 64. Refer to the <i>HF (High Frequency) Application Notes</i> for more information.

- 229 Byte code is invalid. Byte code must be an 8-bit (1 byte) character for Option 64. Refer to the *HF (High Frequency) Application Notes* for more information.
- 230 Lock code is invalid. Lock code must be 0 (Unlock) or 1 (Lock) for Option 64. Refer to the *HF (High Frequency) Application Notes* for more information.
- 400 Invalid character following {.
- 403 Field separator was not found.
- 409 Printer memory is full. Delete unnecessary formats or graphics from memory.
- 410 Parity mismatch.
- 411 Framing error (baud rate mismatch).
- 412 Flow control mismatch.
- 413 Online receive buffer is full. Check for a flow control problem.
- 611 Font, bar code, or density in the batch does not fit the format.
- 612 The data in this line of the batch is either missing or does not match the format.
- 613 Reference point off supply.
- 614 Portion of field off supply or there may be an invalid character in the packet.
- 703 The printer sensed a calibration of different-sized black marks. Make sure the correct supply type is loaded.
- 704 Printer has not sensed a supply mark within the specified number of inches or is out of supplies. Check the supply tracking, supply marks, black mark sensor position, and supply roll for binding. Press **Escape/Clear** and try to continue printing. Change supply.
- 715 Invalid data length/data mismatch. The data in the RFID Data Field has an incorrect data length or there is a data type mismatch between selected data type and actual data entered. This error also occurs when there is an error in the Expanded C1Gen2 fields. Check with your System Administrator about your format. Refer to the *RFIDMP (Multi-Protocol) Application Notes* or the *HF (High Frequency) Application Notes* for more information.
- 740 Command, hardware, inventory, or memory allocation error. There may be an RFID hardware or memory allocation error.

- 741 RFID tag missing. The RFID microchip (tag) not found in RF Field (area inside the printer where RFID tag is programmed). Check supply loading. If you made supply or print position settings, make sure the RFID tag was not moved out of the programmable range.
- 742 Tag erase failed. The RFID microchip (tag) was found in the RF Field, but could not be erased. Refer to the *RFIDMP (Multi-Protocol) Application Notes* or the *HF (High Frequency) Application Notes* for more information.
- 743 Program tag failed. The RFID microchip (tag) was found in the RF Field, but could not be programmed. Refer to the *RFIDMP (Multi-Protocol) Application Notes* or the *HF (High Frequency) Application Notes* for more information.
- 744 Tag locked fail. The RFID microchip (tag) is unable to be programmed, because it is already locked. This is considered a bad RFID tag. Refer to the *RFIDMP (Multi-Protocol) Application Notes* or the *HF (High Frequency) Application Notes* for more information.
- 746 Lock tag fail. The RFID microchip (tag) has not been locked to prevent reprogramming. This is considered a bad RFID tag. Refer to the *RFIDMP (Multi-Protocol) Application Notes* or the *HF (High Frequency) Application Notes* for more information.
- 747 Time out failure. Any RFID command (read, program, etc.) has failed to complete in the maximum amount of allowed time.
- 748 Invalid data length/data mismatch from RFID interrogator module. The RFID interrogator module found a problem with the data received from the printer.
- 749 RFID Verify Fail. The RFID verification process failed after writing (programming) the tag. This is considered a bad RFID tag. Refer to the *RFIDMP (Multi-Protocol) Application Notes* or the *HF (High Frequency) Application Notes* for more information.
- 750 Printhead is overheated. Turn off the printer.
- 751 Printer did not sense a black mark when expected. For errors 751-753, check the supply tracking, supply marks, black mark sensor position, and supply roll for binding. Press **Escape/Clear** and try to continue printing. Change supply.
- 752 Printer sensed a mark in the wrong place.
- 753 Printer sensed a mark that is too long.
- 754 Check for a ribbon jam or remove any slack in the ribbon by turning the take-up reel clockwise. Load a new ribbon.
- 755 Printhead is open. Close the printhead.

- 756 Load supplies.
- 757 Load supplies (supply length mismatch), because the calibrated supply length differs by plus or minus .25 inches from the format. Press **Feed/Cut**.
- 758 Either the supply is not seen or the on-demand sensor is broken. Check for a label jam, clear the supply path, or reload supplies. This error may occur if you remove a label too quickly in the on-demand mode.
- 763 Waiting to dispense label. Press **Feed/Cut**.
- 764 Verifier scan error (bad scan) on label when using normal (no overstrike) mode. Press **Escape/Clear** to clear the error and continue printing. The printer recalibrates (feeds a blank label) after this error.
- 765 The printhead has less than 8 bad dots. The printer can shift bar code fields to avoid bad dots. You may need to press **Escape/Clear** to continue printing. Print a test label to confirm the number of bad dots.
- 768 Printhead has more than 8 bad dots within the format area or is not connected. Connect the printhead.
- 772 Verifier scan error (bad scan) on label or multiple labels in a row when using overstrike and continue mode. The verifier detected three or more bad scans in a row. Press **Escape/Clear** to clear the error and continue printing. The printer recalibrates (feeds a blank label) after this error.
- 773 Verifier failure. The verifier is enabled, but not connected. Make sure the I/O cable and/or serial cable is connected to the verifier. Refer to your verifier's *Operating Instructions* for more information.
- 791 The printer has an error pending. Turn off the printer. Wait 15 seconds (until the power light is completely dim) and turn it back on. Resend the packets.

SPECIFICATIONS



Printer

Height:	13.0 inches (330 mm)
Width:	12.5 inches (318 mm)
Depth:	17.3 inches (439 mm)
Weight	29 lb. (13.2 kg)
Shipping Weight:	34 lb. (15.5 kg)
Power Source:	90-264 VAC with autoselect 50/60Hz
Operating Limits:	For Thermal Transfer (ribbon) 40° to 95°F (4° to 35°C) For Thermal Direct 40° to 104°F (4° to 40°C) Storage: 15°F to 120°F (-9°C to 49°C) Humidity: 5% to 90% non-condensing
Printhead:	Thermal at 4 inches (102 mm) wide 203 dpi (8.0 dots per mm) OR 300 dpi (11.8 dots per mm) This option must be purchased separately.
Printing Method:	Thermal Transfer (ribbon) or Thermal Direct
Print Speed:	2.5 ips (64 mm) default for all serial bar codes, 4.0 ips (102 mm), 6.0 ips (152 mm) default for parallel bar codes, 8.0 ips (203 mm), and 10.0 ips (254 mm). See Chapter 8, "Printing" for special considerations when printing at speeds greater than 6.0 ips. Note: The RFID printer pauses while programming the RFID microchip (tag).
Maximum Print Area:	4.0 inches x 13.0 inches (102 mm x 330 mm)

RF Specifications

The UHF radio operates in the 902 – 928 MHz frequency range in accordance with FCC Rules and Regulations. Additional frequencies may be available for international locations by request. Contact your Paxar RFID Representative for more information.

The HF radio operates at 13.56 MHz in accordance with FCC Rules and Regulations.

RFID Supply Specifications

RFID supplies are available in a variety of sizes. Printing over the RFID inlay causes printing irregularity. Refer to the *RFID Setup Guide & Supply Chart* or the *HF Setup Guide & Supply Chart* for illustrations to determine which type of RFID supplies you are using and basic printer configuration information.

Supply Types: Thermal Transfer or Thermal Direct
Die Cut or Black Mark

Supply Widths: 0.75 inch (19 mm) minimum
4.0 inches (102 mm) maximum

Supply Lengths: 1.0 inch (25.4 mm) minimum
13.0 inches (330 mm) maximum

Note: The supply length depends on the inlay selected.

Roll Inside Diameter: 4.0 inches (102 mm)

Roll Outside Diameter: 8.0 inches (203 mm) maximum

Additional RFID supplies may be available by request. Contact your Paxar RFID Representative for more information.

Tag Cut Dimensions

Use these specifications for the 926™ Knife with the RFMP printer. Use only Paxar® approved RFID tag supplies.

- Widths:** 1.5 inches to 4.0 inches (38 mm to 102 mm)
Lengths: 1.5 inches to 16.0 inches (38 mm to 406 mm)
Thickness: 7 mils to 14 mils
Batch Separator: 3.66 inches (93 mm)

Note: The limited warranty on knives used in or with RFID printers is one (1) year from the date of shipment, or 500,000 cuts, whichever occurs first.

Ribbon Specification

Do not leave ribbon in sunlight, high temperatures or humidity.

Ribbon Type: Standard

Ribbon Widths	Use with Max. supply width
1.5 inches (38 mm)	1.3 inches (33 mm)
1.8 inches (46 mm)	1.5 inches (38 mm)
2.3 inches (58 mm)	2.0 inches (51 mm)
3.3 inches (84 mm)	3.0 inches (76 mm)
4.3 inches (110 mm)	4.0 inches (102 mm)

Ribbon Length: 23,600 inches (600 meters)

About Ribbons

The width of the ribbon must be greater than the supply width. Since some supplies are more abrasive to printheads than others, using a ribbon wider than your supply helps protect the printhead. Replacement printheads are expensive.

Cable Pinouts

The following tables show the connector pins for a 9-pin to 25-pin (126825) cable or a 25-pin to 25-pin cable (126826).

9-Pin (F)	To	25-Pin (M)
CD 1	←	20 DTR
RD 2	←	2 TD
TD 3	→	3 RD
DTR 4	→	8 CD
SGND 5		7 SGND
DSR 6	←	6 DSR
RTS 7		4 RTS
CTS 8	←	5 CTS
N/C 9		1 Shield Drain Wire

25-Pin (F)	To	25-Pin (M)
FG 1		1 FS
TD 2		2 TD
RD 3	←	3 RD
RTS 4		4 RTS
CTS 5	←	5 CTS
DSR 6	←	6 DSR
SG 7		7 SG
CD 8	←	8 CD
N/C 20		20 DTR

ACCESSORIES AND OPTIONS



Accessories

- ◆ 926™ Knife
- ◆ 935™ Rewind
- ◆ 938™ Verifier (Can not be used with 926 Knife)
- ◆ 939™ Keyboard or 939i™ Keyboard
- ◆ 945™ Unwinder
- ◆ Replacement Printhead Kits:
 - 12678301 203 dpi
 - 12678401 300 dpi
- ◆ Ribbon Take-Up Core (11796120, 30, or 40; available in 2", 3", or 4" widths)
- ◆ Monarch® MPCL™ Toolbox (utilities to configure the printer, download fonts, and design formats) available on our Web site (www.paxar.com)
- ◆ External LAN Print Server supports Ethernet and TCP/IP:
 - RJ-45 Connector (10BaseT) 11753101
- ◆ External Ethernet Print Server supports TCP/IP (11753105)
- ◆ Printhead CLEAN-STRIP (120350)
- ◆ Printhead Cleaning Pen (114226)
- ◆ Cables: 9-pin to 25-pin (126825), 25-pin to 25-pin (126826)

Note: You can use either the optional knife or peel mode, but not both.

Packaging Materials

If you need to ship the printer to a different location and do not have the original packaging, use the following part numbers to order the appropriate packaging materials.

Plastic Cover Printers	Description and Qty.	Metal Cover Printers	Description and Qty.
00065501	Carton (1)	00066101	Carton (1)
00065502	Corrugated Pad (1)	00066102	Foam Pad Set (1)
00065503	Corrugated Pad (1)	00066105	Corrugated Pad (1)
00065507	Foam Pad Set (1)		

Factory-Installed Options

- ◆ 7411™ Print Server for 802.11b wireless networks (also supports wired Ethernet printing).
- ◆ 300 dpi printhead (12678401)
- ◆ Internal TwinAx/CoAx Protocol Converter (117532) also Service-installable)
- ◆ Internal Ethernet Print Server supports TCP/IP (11753104)
- ◆ Peel mode with on-demand sensor
- ◆ Knife-ready (order Knife separately)

Ethernet Information

Paxar® offers internal and external Ethernet connectivity solutions. These solutions make it easy to set up, manage, and monitor a printer linked to an Ethernet connection. The print server provides multiprotocol capabilities for users with Windows® 95/98/2000 or Windows NT®, TCP/IP, and NetWare®. Software is available on our Web site (www.paxar.com) to configure the print server. It can also be configured using HP Jet Admin™ or HP Web JetAdmin™ software.

Configuration information prints automatically if the Ethernet print server senses a hardware error. To print configuration information on demand, press the *Test* button on the side of the external Ethernet print server unit or use the configuration utility provided for your network operating system. The configuration label prints in MPCL format.

Note: The configuration label is best displayed using 4" wide by 6" long labels. If the label is too small, some information may print outside the label edges.

RF Information

We offer the 7411 Print Server that communicates with printers on an 802.11b wireless network. You can use the print server in ad-hoc (peer-to-peer) or infrastructure (access point) wireless mode. In addition, the wireless print server includes a unique dual-mode built-in wired Ethernet connection. You can switch between wired and wireless mode without any loss of data.

GLOSSARY

The following terms will help you use this manual.

antenna	A device used to transmit and receive radio frequency communications. The printer's antenna is located between the platen roller and supply guide inside a bracket.
attenuation	Reduces the strength of the RF Field emitted by the RFID printer's antenna.
continuous mode	Mode in which the printer prints all the labels in the batch without stopping.
download (send)	Transmission of data from the host to your printer.
EPC	The Electronic Product Code, which is a numbering standard for items, similar to the UPC code for bar coding. The EPC is divided into several sections: Header, Manager Number, Object Class, and Serial Number.
format	Supply layout or design, which the <i>System Administrator</i> downloads as a format packet to your printer.
HF	High Frequency is a range of frequencies between 3 MHz and 30 MHz. The RFID tags operate at 13.56 MHz.
host	Any mainframe, minicomputer, data collect terminal, or personal computer sending data to the printer.
inlay	A type of media that contains a transponder (microchip with antenna) and is converted for use in Monarch® RFID supplies (tags). Inlays can be made with different types of transponders (Class 0, Class 1, etc.).
interrogator	The electronics module that programs the RFID tags through the antenna. The interrogator is connected to the printer's I/O board, near the printer's main CPU board.
LCD	Display on the printer used to indicate printer conditions and problems.
leader	Wrap around a new roll of ribbon with printing on it.
on-demand mode	Mode in which the printer stops after each label to allow you to remove it.

print job (batch)	Actual data printed on a label or tag. The host may download the print job together with the format, or as a separate packet. The print job is also called a "batch."
protocol	A standard method of communicating between devices (computers, printers, RFID readers, RFID tags, etc.). Class 1 is an example of the many protocols that exist.
online	Direct communication between a computer and the printer.
read power	The strength of the RF Field emitted by the antenna to read the data in the RFID tag. If set too low, you may not be able to read the data.
RF Field	Area inside the printer where the RFID tag is programmed. The RF Field area is controlled by the attenuation level and the antenna. The printer's antenna is located between the platen roller and supply guide inside a bracket.
RFID Data Field	The Monarch® Printer Control Language II (MPCLII) Data Field containing the information to program into an RFID tag.
RF Power	Increases the strength of the RF field emitted by the printer's antenna to read (read power) and program (write power) the RFID tags.
RFID Reader	An optional external device that reads the RFID tags after they are programmed.
RFID Tags	Supplies that contain an embedded programmable microchip and antenna. These can also be referred to as a transponder. The RFID tag is inserted into either label or tag stock for use in Monarch® printers.
signal adjust	The strength of the RF Field emitted by the printer's antenna.
supply sensor	Senses whether supply is loaded or needs to be loaded in the printer. Located in the supply path.
supplies	Labels or tag stock used for printing.
System Administrator	Person responsible for creating and downloading packets.

transponder	The combination of the embedded programmable microchip with an antenna on some type of media (film, paper, etc.). Different types of transponders are available, for example, Class 1 Gen1 or Class 1 Gen2. These can also be referred to as RFID tags.
UHF	Ultra High Frequency is a range of frequencies between 300 MHz and 3 GHz. The frequencies vary according to the country of use. In the United States, the frequency range is 902 – 928 MHz.
write power	The strength of the RF Field emitted by the antenna to program data into the RFID tag. If set too high, you may accidentally program adjacent RFID tags.
write retries	The number of times the interrogator tries to program the RFID tag in the RF Field.

Visit **www.paxar.com** for sales, service,
supplies, information, and telephone numbers
for our International locations.

TOLL FREE:

1-800-543-6650 (In the U.S.A.)

1-800-363-7525 (In Canada)