

System Administrator's Guide

Monarch® 9460™ SNP
& 9493™ SNP Printers

802.11b/g Wired/Wireless

- Web Browser
- Avalanche™ Management Console
- Telnet
- Ethernet

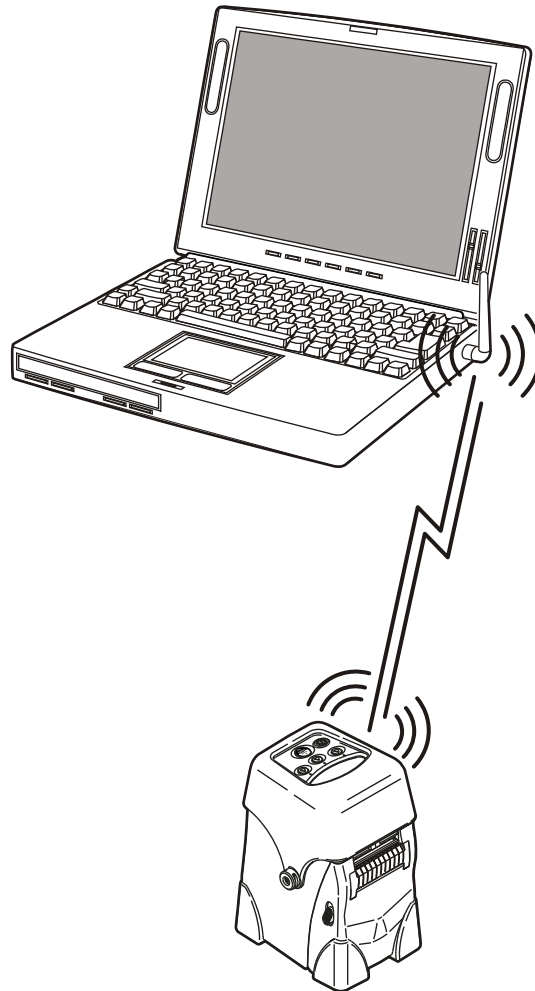

Each product and program carries a respective written warranty, the only warranty on which the customer can rely. Avery Dennison reserves the right to make changes in the product, the programs, and their availability at any time and without notice. Although Avery Dennison has made every effort to provide complete and accurate information in this manual, Avery Dennison shall not be liable for any omissions or inaccuracies. Any update will be incorporated in a later edition of this manual.

©2007 Avery Dennison Corporation. All rights reserved. No part of this publication may be reproduced, transmitted, stored in a retrieval system, or translated into any language in any form by any means, without the prior written permission of Avery Dennison Corp.

Trademarks

Monarch® and Sierra Sport, 9460, and 9493 are trademarks of Avery Dennison Retail Information Services, LLC.

Avery Dennison® is a trademark of Avery Dennison Corporation.

Centronics is a trademark of Centronics Data Computer Corporation.

Microsoft® and MS-DOS are trademarks of Microsoft Corporation.

Bluetooth® is a trademark of Bluetooth SIG, Inc.

Windows and NT are trademarks of Microsoft in the U.S. and other countries.

Hewlett-Packard is a trademark of Hewlett-Packard Company.

Firefox® is a trademark of Mozilla Corporation.

HP Jet Admin, HP JetDirect, and HP Web Jet Admin are trademarks of Hewlett-Packard Company.

Novell and NetWare are trademarks of Novell, Inc., in the United States and other countries.

Wavelink and Avalanche are trademarks of Wavelink Corporation.

Avery Dennison Printer Systems Division
170 Monarch Lane
Miamisburg, OH 45342



TABLE OF CONTENTS

GETTING STARTED	1-1
Overview	1-1
Audience	1-1
Using This Manual.....	1-1
System Requirements	1-2
Network Protocols Supported	1-2
9493™ Printer Hardware	1-2
CONFIGURING THE 802.11b/g AND IP SETTINGS	2-1
Configuring the Print Server	2-1
Before You Begin	2-1
Setting Up the 9460™ Using Direct Serial Connections	2-1
Setting up the 9493™ Using Direct Serial Connections.....	2-2
Installing the Software	2-2
Setting Up Using the Printer's Menu.....	2-3
Setting Up the 9460™ Printer	2-4
Checking the Status	2-5
Configuring the Printer	2-5
Printing a Network Information Label	2-8
Setting Up the 9493™ Printer	2-9
Using the Network Menu	2-10
Checking the Status	2-10
Configuring the Printer	2-10
Printing a Network Information Label	2-14
Printing Info.....	2-15
Resetting the Radio.....	2-15
SELECTING A MANAGEMENT METHOD	3-1
HP JetAdmin Utility	3-1
HP Web JetAdmin Utility	3-1
Microsoft® Windows® Network Configuration.....	3-1
Additional Windows Configuration Methods	3-1
UNIX Network Configuration	3-1
Berkeley UNIX Host Configuration.....	3-2
Sun Solaris Configuration	3-2
HP/UX Configuration	3-3
IBM AIX Configuration	3-4
Configuration on Other Systems	3-4

USING A WEB BROWSER.....	4-1
Logging In	4-1
Contacting Us	4-2
Configuring the Server Settings	4-2
Configuring the Print Port Settings	4-3
Configuring Print Services.....	4-3
Setting Netware Parameters	4-4
Changing TCP/IP Settings	4-5
Configuring PrintraNet	4-6
Configuring Wireless Settings.....	4-6
Configuring Alerts and Traps	4-7
Receiving An Alert	4-8
SNMP IP Traps	4-9
SNMP Netware Traps	4-10
Changing the Passwords.....	4-11
Setting the Network Card Access Password.....	4-11
Setting the Network Card Update Password.....	4-12
Configuring Network Protocols.....	4-12
Controlling IP Access	4-13
To Add Hosts:.....	4-13
To Remove Hosts.....	4-13
Configuring Network Security	4-13
Printing a Test Page	4-14
Using the Console	4-14
Updating Firmware	4-14
To update from a TFTP server:.....	4-15
To update from a file on your computer:	4-15
Loading the Firmware	4-15
Basic Security Configurations	4-16
USING THE SIERRA SPORT CONFIGURATOR	5-1
System Requirements	5-2
Before You Begin	5-2
Changing the Avalanche Directory	5-2
Configuring Wireless Settings.....	5-3
Configuring the Extended Security Settings	5-3
Configuring the Print Server Settings	5-3
Configuring Services	5-3
Configuring TCP/IP Settings.....	5-4
Specifying the IP Access Range	5-4
Configuring Printranet Settings.....	5-4
Configuring NetWare Settings.....	5-4
Setting Alerts and Traps	5-5
Configuring Printing Settings	5-5
Updating Files	5-6
Saving Changes	5-6
Creating Your Own Packages	5-6

TELNET CONSOLE COMMANDS **6-1**
 Conventions 6-1
 Settings 6-1
 Help Commands 6-2
 General Commands 6-3
 Avalanche Console Commands 6-5
 Port Commands 6-5
 802.11b/g Wireless Commands 6-5
 TCP/IP Commands 6-7
 SNMP Commands 6-9
TROUBLESHOOTING **7-1**
 General Troubleshooting Information 7-1
 Troubleshooting Wireless Configuration Problems 7-2
 Troubleshooting Network Configuration 7-2
 Technical Support 7-2
SPECIFICATIONS **A-1**
 802.3 Specifications (9493™ only) A-1
 802.11b/g Specifications A-1
GLOSSARY **G-1**
INDEX **i**

GETTING STARTED

1

Use these instructions to configure your Monarch® Sierra Sport2™ 9460™ SNP printer or your Monarch® Sierra Sport4™ 9493™ SNP printer. Your printer contains an 802.11b/g print server (radio), which lets you communicate with your printer on a wired Ethernet 802.3 network (9493 printer only), or on an 802.11b or 802.11g wireless network. 802.11b/g refers to 802.11b and 802.11g in this manual.

The 9460 printer (version 3.0 or greater firmware and version 1.4 or greater boot loader) also includes support for the Wavelink® Avalanche™ Management Console software.

Information in this document supercedes information in previous versions. Check our Web site for the latest documentation and release information.

Overview

You can use the print server in Ad-Hoc (peer-to-peer) or infrastructure (access point) wireless mode. The print server operates at speeds of up to 11 Mbps on any IEEE 802.11b and 54 Mbps on any IEEE 802.11g wireless compatible networks.

The 9493 wireless print server includes a dual built-in wired Ethernet (802.3) connection so the print server automatically switches between wireless and wired Ethernet mode within the same subnet address. When switching between wired and wireless mode on different subnets, turn off the printer and then turn it back on to reinitialize the radio.

Follow the instructions in this manual to configure the wireless print server for your printer. For more information and software downloads, see Chapter 7, "Troubleshooting."

Audience

This manual is written for the System Administrator who sets up printers on the network and is familiar with basic networking principles.

Using This Manual

Following is a summary of the contents of this manual.

	Chapter	Contents
1	Getting Started	Information you should know before using the printer.
2	Configuring the 802.11b/g and IP Settings	Setting communications between your network and printer.
3	Selecting a Management Method	Explains the various ways to configure and monitor your network printer.
4	Using a Web Browser	Using your Web browser to configure and monitor your network printer.
5	Using the Sierra Sport Configurator	Configure and monitor your network printer using the Sierra Sport Configurator with the Avalanche Management Console software.
6	Telnet Console Commands	Lists the supported console commands for your network printer.
7	Troubleshooting	Common problems and their solutions.
A	Specifications	Printer and radio specifications.
G	Glossary	Networking and printer terms and their definitions.

System Requirements

To use the print server for printing from a wireless network, you need an 802.11b/g wireless network. The wireless network consists of either of the following:

- ◆ An 802.11b/g wireless enabled computer printing straight to the printer (Ad-Hoc, or peer-to-peer, mode).
- ◆ An 802.11b/g wireless access point allowing wireless enabled computers to print to the print server (infrastructure mode).

To configure and print, you need the following information from your wireless network administrator:

- ◆ Wireless Mode (infrastructure or Ad-Hoc)
- ◆ The SSID (service set identifier) for your wireless network.
- ◆ If you are using TCP/IP (recommended for Windows Networks) and are not connected to a server that automatically assigns your IP address, you need to set the printer in Static mode and assign a unique IP address (for example: 192.168.1.14) and a subnet mask. A router (default gateway) address is optional.
- ◆ Wireless security settings

Network Protocols Supported

- ◆ TCP/IP:
 - LPD/LPR, FTP, or IPP
 - Raw TCP/IP (port 9100 or any chosen port)
 - NetBIOS over IP (with SMB)
 - NetWare (NEST)
 - NetBEUI
 - DLC
- ◆ Telnet
- ◆ WINS
- ◆ DHCP

9493™ Printer Hardware

To access the Ethernet port, open the hinged door on the side of the printer by loosening the two screws with a Phillips screwdriver.

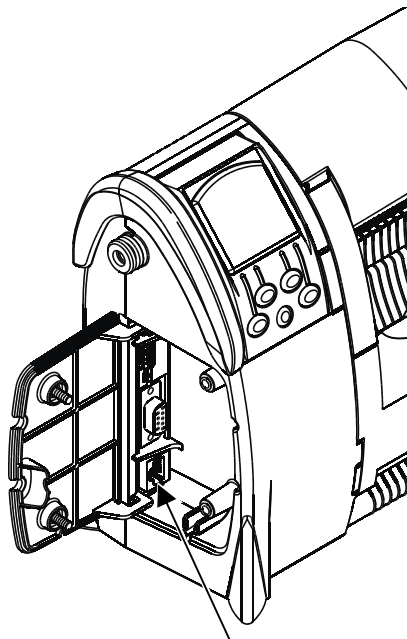

Ethernet Port

CONFIGURING THE 802.11B/G AND IP SETTINGS

Configuring the Print Server

To configure the print server for an 802.11b/g wireless network, you must set the wireless mode (Ad-Hoc or infrastructure), SSID, channel (Ad-Hoc mode only), data rate and security. All nodes of a wireless network need to have the same settings to communicate with each other.

There are several ways to configure your print server. You can

- ◆ send console commands using a utility such as Monarch® NetManager. See “Installing the Software” for NetManager information.
- ◆ use a Web browser. See Chapter 4, “Using a Web Browser” for more information.
- ◆ use the Sierra Sport Configurator with Avalanche. See Chapter 5, “Using the Sierra Sport Configurator” for more information.
- ◆ use Telnet. See Chapter 6, “Telnet Console Commands” for a list of supported commands.
- ◆ select the RF Network (9460) and Network (9493) printer menus. See “Setting Up Using the Printer’s Menu.” The printer’s menus allow you to do basic setup.

Before You Begin

Configure your computer to communicate on a wireless network before you continue.

- ◆ To connect a device using an access point, set your computer to infrastructure mode.
- ◆ To connect directly to a device without an access point, set your computer to Ad-Hoc Computer-to-Computer mode, or whatever mode your adapter uses to communicate without an access point.
- ◆ To use Ad-Hoc mode, temporarily disable security on your access point. After the print server is configured, re-enable security on the access point.
- ◆ To use WEP (Wired Equivalent Privacy) encryption or other advanced security, such as WPA (Wi-Fi Protected Access), on your wireless network, temporarily disable the security on your computer in order to configure the print server. To allow non-secure clients to communicate with each other, temporarily change the wireless mode of your host to Ad-Hoc mode.
- ◆ To use TCP/IP, note your computer’s IP address. The print server needs to be on the same IP segment as the other nodes on your network in order to communicate.
- ◆ You need a good signal between your computer and the access point to communicate.

Setting Up the 9460™ Using Direct Serial Connections

1. Disconnect the printer’s radio cable from the printer’s serial port.
2. Connect a serial cable (DB9 female to DB9 female all lines wired straight through) from the host or computer to the print server’s radio cable.

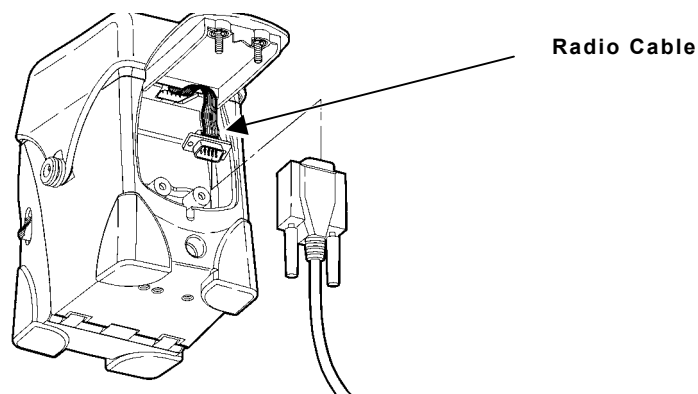

3. Turn on the printer and configure using Telnet or other communications program.
4. Connect the printer's radio cable to the printer's serial port.

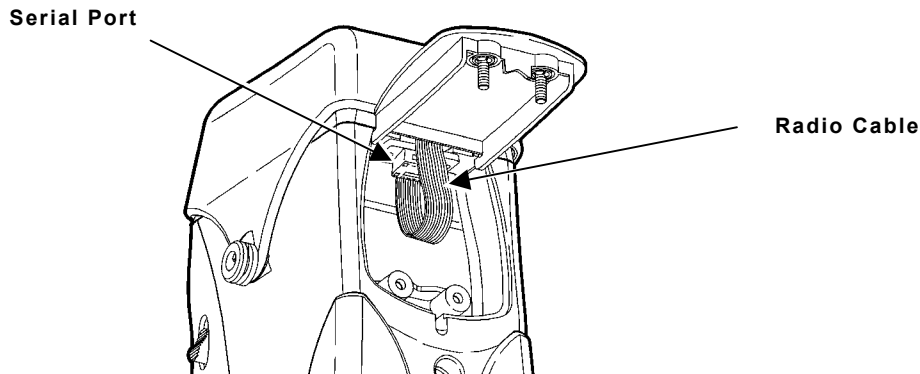

5. Turn off the printer, wait a few seconds, and then turn on the printer.
Your printer is ready to use.

Setting up the 9493™ Using Direct Serial Connections

Use a serial cable or a USB cable for direct communication with the printer. The USB port can function as either a serial port or a parallel port. Refer to the *System Administrator's Guide* for more information about changing the USB port's function.

1. Open the hinged cable door on the side of the printer by loosening the two screws with a Phillips screwdriver.
6. Plug the DB9 connector into the DB9 port or plug a USB type A or USB mini-B connector into the corresponding USB port as show.
7. Place the cable in one of the cable cavities.
8. Turn on the printer and configure using Telnet or other communications program. See Chapter 6, "Telnet Console Commands" for more information.
9. Turn off the printer, wait a few seconds, and then turn on the printer.

Your printer is ready to use.

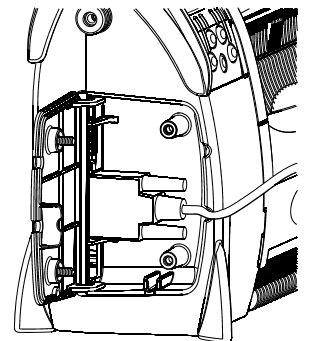

DB9 cable shown

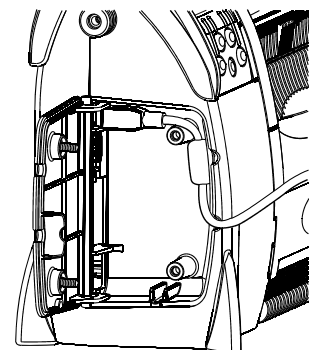

USB mini-B cable

Installing the Software

The software works with Microsoft® Windows® NT® 4, 2000, XP, and Vista™ operating systems. Follow these steps to install the NetManager software and configure the print server. You can also download the utility from our Web site.

1. Insert the Monarch® Printer Documentation CD-ROM (TC9X00SWP) into your computer.
2. Select Drivers & Utilities, then NetManager.

3. Follow the on-screen instructions for installing the utility. When NetManager starts for the first time, you see the NetManager Welcome screen. You are prompted to enter a View Name (sets up how print servers are discovered and displayed on your network). Then, select the protocol and filter settings or “Automatically create a view with default settings.”
 4. Select **Finish** to begin searching for print servers. NetManager gets the information from the print server(s) and lists the server name, IP address, and hardware (Ethernet) address. The default name of the print server is PXRxxxxxx, where xxxxxx is the last 6 digits of the hardware address (for example, PXR08B2C7).
- Note:** It might take a minute or two for the print server to appear, especially on a large wireless network.
5. When you see the print server you need to configure in the list, highlight it and click the Configuration tool.
- Note:** A wireless signal of less than 50% on the Wireless Status screen, could affect printing performance. To improve the signal strength, move the print server closer to the computer or access point and away from other radio devices such as Bluetooth® wireless devices, microwave ovens, or 2.4 gigahertz cordless phones.
6. Configure your print server to the settings you need. Many of the fields are automatically configured to match the network being used, so you may not need to change the Wireless Mode, RF Channel, SSID, and Data Rate settings unless you need to change the print server to a different wireless network.
 - ◆ To use WEP encryption or other advanced security, enable the security and enter the appropriate key(s).
 - ◆ To use TCP/IP without a DHCP server, manually assign a valid IP address, subnet mask, and gateway and then set the boot method to static.
- Note:** If you are using DHCP on your network, the print server may have acquired valid IP settings at this point and no further configuration is necessary. This works if your DHCP server allows the print server to keep this address permanently. However, in most cases, use a static address outside the range reserved for DHCP (Refer to your DHCP server documentation for details). When you configure your printer port, it goes to a static IP address.
7. When you are done configuring, click OK. You are prompted to save changes and reset the print server. Click OK. The print server resets with your new configuration. This may take several minutes.

Setting Up Using the Printer’s Menu

You can use the printer’s menu to configure some basic network settings. Follow the instructions for your printer: 9460 or 9493.

Setting Up the 9460™ Printer

Use these instructions to set up a 9460 printer using the printer's RF Network menu in the printer's Tool Box.

1. Turn on the printer by pressing and holding the power button (Ⓜ) until the display turns on. The display flashes printer version information and battery charging status.



When you see "Init Radio", the printer is waiting for the wireless print server to initialize. Next, you may see

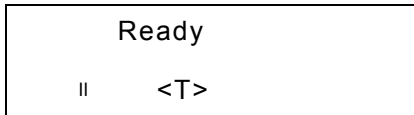

Display	Indicates
Ready	The printer is in Ready mode to send and receive data.
<T>	The printer is connected to a network (peer-to-peer or infrastructure mode). Press ▲ under <T> to display the printer's IP address, then press ▲ under ☰ to print a network information label with the device name, IP address, and MAC address as a bar code. See "Printing a Network Information Label" for more information. Press any button to return to Ready mode.
✕	The printer is not connected to a network.

2. Press ▲ under ||.

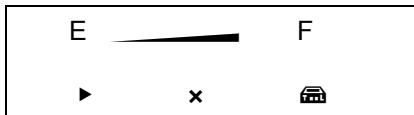

You see the battery indicator E (empty) and F (full). As you use the printer, the battery indicator line gets closer to E (empty), instead of F (full). Recharge the battery when the line is by the E.

3. Press ☰ (Tool Box) to enter the menu.

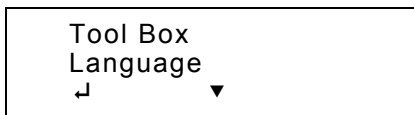

4. Tool Box is highlighted. Press ↵ to select **Tool Box**.

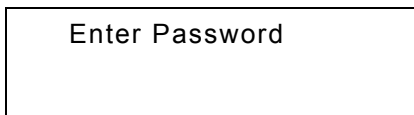

5. Press the navigational buttons in this order: **Left, Left, Left, Right, and Left**.

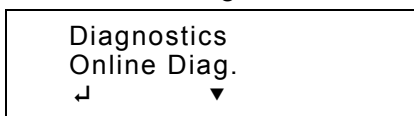

6. Press ▼ until Setup is highlighted.

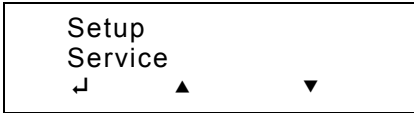

7. Press ↵ to select **Setup**.
8. From the Setup menu, press ▼ until you see RF Network. Press ↵ to select RF Network.

The RF Network menu allows you to check the printer's status, configure the RF network settings, print RF settings, and reset the radio.

To exit, press ⓘ at any time.

Checking the Status

This option displays the status of the RF network.

1. From the RF Network menu, select **Status**.

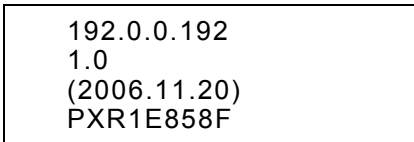

The local IP address, firmware version, printer model, board revision, and device name are displayed.

2. Press ▲ to see the next screen of information.

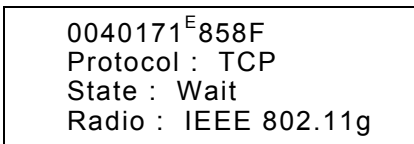

The MAC address, protocol, current state, and radio type are displayed.

3. Press any ▲ to return to the RF Network menu.

Configuring the Printer

The Configure menu allows you to set the printer's IP address, subnet mask, gateway, power mode, protocol, SSID, and escape character.

To exit, press ⓘ at any time.

Setting the IP Address



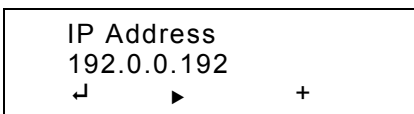

This option sets the printer's IP address.

1. From the RF Network menu, select **Configure**.
2. From the Configure menu, select **IP Address**.



For:	Select:
BOOTP	0.0.0.0
DHCP	0.0.0.1
Static IP	<i>nnn.nnn.nnn.nnn</i>

Use the  buttons as shown in the following table:

 Press  to	 Press  to	+ Press  to
Saves the setting	Scrolls through the positions from left to right	Increments the current position setting by 1



- When the setting you want is displayed, press  to save the setting. You return to the Configure menu.

Setting the Subnet Mask





This option sets the printer's subnet mask.

- From the Configure menu, select **Subnet Mask**.

Subnet Mask
255.255.000.000

  **+**

Use  as shown in the following table:

 Press  to	 Press  to	+ Press  to
Saves the setting	Scrolls through the positions from left to right	Increments the current position setting by 1



- When the setting you want is displayed, press  to save the setting. You return to the Configure menu.

Setting the Gateway





This option sets the printer's router (gateway) address.

- From the Configure menu, select **Gateway**.

Gateway
000.000.000.000

  **+**

Use  as shown in the following table:

 Press  to	 Press  to	+ Press  to
Saves the setting	Scrolls through the positions from left to right	Increments the current position setting by 1

- When the setting you want is displayed, press  to save the setting. You return to the Configure menu.

Setting the Power Mode



This option sets the power mode.

- From the Configure menu, select **Power Mode**.

Power Mode

X CAM

✓ PSP

The choices include CAM (Continuous Awake Mode) or PSP (Power Save Protocol). PSP conserves battery power. CAM means the printer is continuously receiving and transmitting data. This mode uses battery power quickly.

- Use **▼** to select the power mode you want. Press **↵** to save the setting.
If you select PSP, you are prompted to enter a PSP algorithm between 1-5.

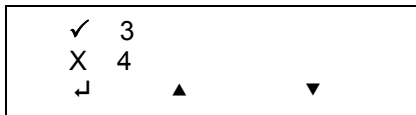

1 = shortest sleep time (uses battery power quicker, but responds faster); **5** = longest sleep time (optimal battery conservation, but responds slower).

- Use **▲** or **▼** to select the PSP algorithm you need. Press **↵** to save the setting. Select **Exit** to return to the Configure menu.

Setting the Port

This option sets the port.

- From the Configure menu, select **Port**: TCP or LPD.

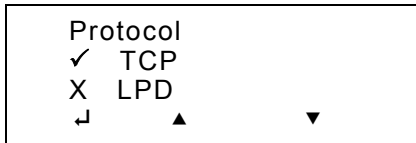

- Use **▼** to select the protocol you want. For example, if you select LPD, you must specify a raw printer port:

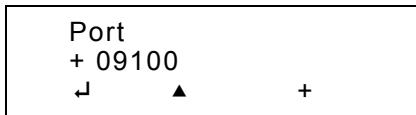

Use **⬆** as shown in the following table:

↵ Press ⬆ to	▶ Press ⬆ to	+ Press ⬆ to
Saves the setting	Scrolls through the positions from left to right	Toggles between + or -; also increments the current position setting by 1

- Press **↵** to save the setting. You return to the Configure menu.

Setting the SSID

This option sets the SSID. The SSID is case-sensitive.

- From the Configure menu, select **SSID**.



Use **⬆** as shown in the following table:

↵ Press ⬆ to	▶ Press ⬆ to	+ Press ⬆ to
Saves the setting	Scrolls through the positions from left to right	Increments the current position setting by 1 and scrolls through alpha/special characters





- When the setting you want is displayed, press **↵** to save the setting. You return to the Configure menu.



Setting the Command Escape Character

1. This option allows you to set or view the Command Escape Character (CEC).
2. Run-time messages from the radio begin with the CEC and the default is the pound sign (#), which has a decimal value of 35. You may need to change the default CEC character if it conflicts with other data, because an unexpected operation could occur. The range is a decimal value between 1 and 255.
3. From the Configure menu, select **Escape**.





Use  as shown in the following table:

 Press  to	 Press  to	+ Press  to
Saves the setting	Scrolls through the positions from left to right	Increments the current position setting by 1

4. When the setting you want is displayed, press  to save the setting. You return to the Configure menu.
5. Press  to exit.

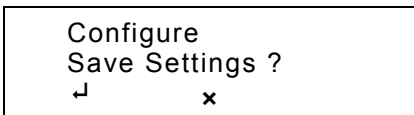
When you select “Exit” after configuring, you will see



To save all the configuration settings, press . To exit without saving the configuration settings, press **x**. Press  until you see “Ready.”

Note: You must reset the RF network before your changes take effect. See “Resetting the RF Network” for more information.

Printing a Network Information Label

You can print a network information label with the device name, IP address, and MAC address as a Code 128 bar code. You can also print the network information as a Code 39 bar code with the correct MIF settings.

1. Turn on the printer.
2. Press  under <T>. You see the printer’s IP address. For example,

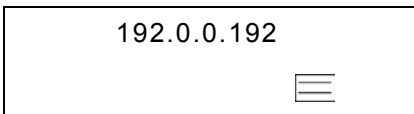

3. Press  under  to print a network information label.

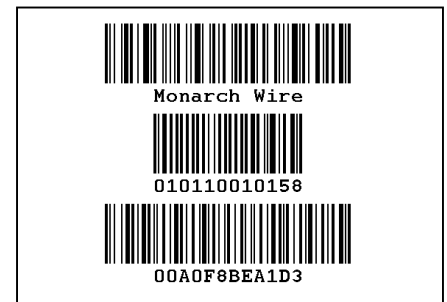

Sample Label

Setting Up the 9493™ Printer

Use these instructions to set up a 9493 printer using the printer's Network Setup menu.

















1. Turn on the printer by pressing .

The display flashes printer version information and battery charging status. Then you may see



The  indicates the wireless signal strength.

Note: When using wired Ethernet, connect the network cable **before** you turn on the printer. The print server cannot detect the connection if the printer is already on.

Display	Indicates
Ready	The printer is in Ready mode to send and receive data.
	The printer is connected to a network (peer-to-peer or infrastructure mode). Press  under  to display the printer's IP address. Press  then  to view network information. Press  to print a network information label with the device name, IP address, and MAC address as a bar code. See "Printing a Network Information Label" for more information. Press  to return to Ready mode.
	Shows the wireless signal strength between the printer and the network.
	The printer is not connected to a wireless network.
	The printer is connected to a wired Ethernet 802.3 network. Press  under  to display the printer's IP address. Press  then  to view network information. Press  to print a network information label with the device name, IP address, and MAC address as a bar code. See "Printing a Network Information Label" for more information. Press  to return to Ready mode.
	The printer is not connected to a wired Ethernet network.

2. Press  under .

You see the Pause screen with the battery indicator E (empty) and F (full). As you use the printer, the battery indicator line gets closer to E, instead of F. Recharge the battery when the line is by the E.



3. Press **⏏** under **⚙** to enter the main menu.
4. Tools is highlighted. Press **⏏** to select **Tools**.
5. Press **⏏** under the corresponding number to enter the following default password:
1, 1, 1, 3, 1.



6. Press **↓** until Setup is highlighted. Press **⏏** to select **Setup**.

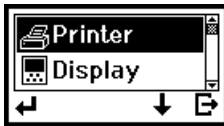

7. Press **↓** until Network is highlighted. Press **⏏** to select **Network**.

Using the Network Menu

The Network menu allows you to check the printer's status, configure the network settings, print the settings, and reset the radio.

To exit, press **⏏** until you return to the Pause screen.

Checking the Status

This option displays the status of the network.

1. From the Network menu, select **Status**.

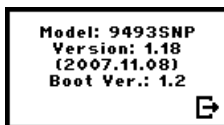

You see the printer model, firmware version, and bootloader version.

2. Press **⏏** to move through the next four screens of information.

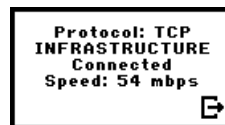
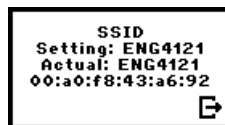
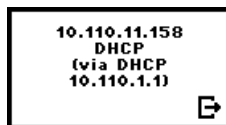
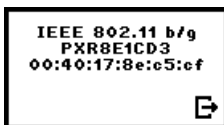

You see the radio type and MAC address, local IP address, SSID, protocol, network mode, status, and connection speed.

3. Press **⏏** again to return to the Network menu.

Configuring the Printer

The Configure menu allows you to set the printer's IP address, subnet mask, gateway, power mode, port, SSID, encryption type, keys, and escape character. You can also enable or disable Ad-Hoc mode.

From the Network menu, select **Configure**.

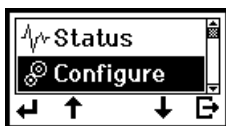

To exit, press **⏏** until you return to the Pause screen.

Setting the IP Address

This option sets the printer's IP address.

1. From the Network Configure menu, select **IP Address**.

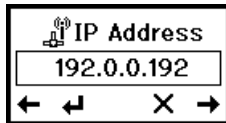

2. Press \downarrow or \uparrow to increase or decrease the highlighted number. Press \leftarrow or \rightarrow to highlight a different number.
3. When you are finished, press \rightarrow until you see \leftarrow . Then press \leftarrow to save the address and return to the Configure menu. Press **X** to exit without saving changes.

Setting the Subnet Mask

This option sets the printer's subnet mask.

1. From the Network Configure menu, select **Subnet Mask**.

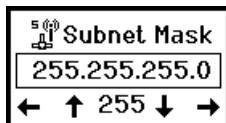

2. Press \downarrow or \uparrow to increase or decrease the highlighted number. Press \leftarrow or \rightarrow to highlight a different number.
3. When you are finished, press \rightarrow until you see \leftarrow . Then press \leftarrow to save the address and return to the Configure menu. Press **X** to exit without saving changes.

Setting the Gateway

This option sets the printer's router (gateway) address.

1. From the Configure menu, select **Gateway**.

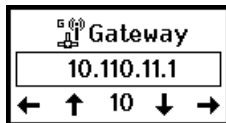

2. Press \downarrow or \uparrow to increase or decrease the highlighted number. Press \leftarrow or \rightarrow to highlight a different number.
3. When you are finished, press \rightarrow until you see \leftarrow . Press \leftarrow to save the address and return to the Configure menu. Press **X** to exit without saving changes.

Setting the Power Mode

This option sets the power mode to CAM (Continuous Awake Mode) or PSP (Power Save Protocol). PSP conserves battery power. CAM means the printer is continuously receiving and transmitting data. This mode uses battery power quickly.

1. From the Configure menu, select **Power Mode**.

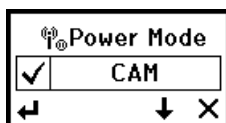

A checkmark indicates the current option.

2. Press \uparrow or \downarrow until you see the power mode you need. Press \leftarrow to enable it.

Note: If you select PSP, you are prompted to enter a PSP algorithm between **1-5**. **1** - shortest sleep time (uses battery power quicker, but responds faster); **5** - longest sleep time (optimal battery conservation, but responds slower).

3. Press **↑** or **↓** to select the PSP algorithm you need.
4. Press **↵** to save the setting and return to the Configure menu. Press **✕** to exit without saving changes.

Setting the Port

This option sets the port. The default port is 9100.

1. From the Configure menu, select **Port**.

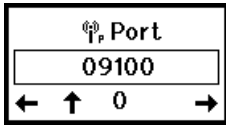

2. Press **↓** or **↑** to increase or decrease the highlighted number. Press **←** or **→** to highlight a different number.
3. When you are finished, press **→** until you see **↵**. Press **↵** to save the setting and return to the Configure menu. Press **✕** to exit without saving changes.

Setting the SSID

This option sets the SSID. The SSID is case-sensitive.

1. From the Configure menu, select **SSID**.

The default or last-saved SSID appears, for example:

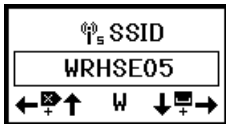

2. Press **↓** or **↑** to change the highlighted character. Press **←** or **→** to highlight a different character.
3. When you are finished, press **→** until you see **↵**. Press **↵** to save the setting or press **✕** to exit without saving changes.

Enabling Ad-Hoc Mode

The default mode for the radio is infrastructure (access point). You must enable Ad-Hoc mode to connect peer-to-peer.

1. In the Configure menu, Press **↓** or **↑** until AD HOC is highlighted.

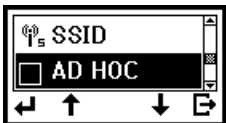

2. Press **↵** to enable AD HOC.

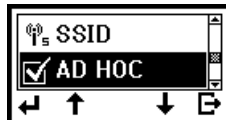

A checkmark appears when AD HOC mode is enabled.

3. Press **↵** to return to the Network menu.

Setting the Encryption

This option allows you to set the printer's encryption method to None, WEP 64, WEP 128, WPA, WPA2, or WPA2/WPA. The default is None (no encryption).

1. From the Configure menu, select **Encryption**.

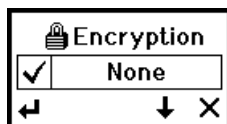

A checkmark indicates the current setting.

2. Press ↓ or ↑ until you see the encryption you need, then press ← to enable it and return to the Configure screen. Press X to exit without saving changes.

Note: When you use encryption, you must set the keys to secure your network. See “Setting the Encryption Keys” for more information.

Setting the Key Index

This option sets the key to use for the selected encryption method.

See “Basic Security Configurations” for more information on encryption keys.

1. From the Configure menu, select **Keys**.

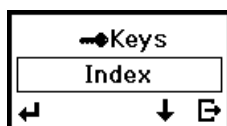

2. Select **Index**.



You can select up to four 104-bit keys using keys 1-4, or up to two 128-bit keys using keys 1 and 3.

3. Select the key you need and press ← to save the setting or press X to exit without saving changes. You return to the Keys menu.
4. Enter the key values. See “Setting the Encryption Keys” for more information.

Setting the Encryption Keys

Use this option to set the key values for encryption. Once you save a key and exit the option, you cannot view the key values. There are four keys. Refer to “Basic Security Configurations” in Chapter 4 for more information on setting encryption key values based on your encryption method.

Note: Since you cannot view key values, keep a list of your key values in a safe place for future reference.

After you set the key values, select a key to use based on your network's encryption method. See “Setting the Key Index” for more information.

1. From the Configure menu, select **Keys**.

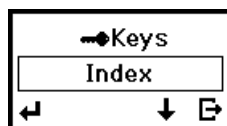

2. Press **↓** or **↑** until you see the key you need to set, then press **↵** to edit the value.
For example:

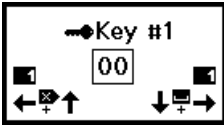

3. Press **↓** or **↑** to scroll through the hex characters for each field. The hex characters appear in the box and the ASCII equivalent character appears under the hex character.
4. Press **→** to select the character shown and move to the next field.
5. When you are finished, press **→** until you see **↵**. Press **↵** to save the setting or press **X** to exit without saving changes. You return to the Keys menu.

Setting the Escape Character

1. This option allows you to set or view the Escape Character (EC).
2. Run-time messages from the radio begin with the EC and the default is the pound sign (#), which has a decimal value of 35. You may need to change the default EC character if it conflicts with other data, because unexpected operation could occur.
3. From the Configure menu, select **Escape Char**.

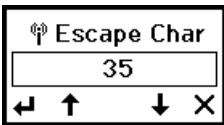

4. Press **↓** or **↑** to decrease or increase the decimal value.
5. Press **←** or **→** when you are finished. Press **↵** to save the setting or **X** to exit without saving changes. You return to the Configure menu.

The radio is now configured. Press **↵** until you return to the Pause screen.

Printing a Network Information Label

You can print a network information label with the device name, IP address, and MAC address as a Code 128 bar code. You can also print the network information as a Code 39 bar code with the correct MIF settings.

1. Turn on the printer.
2. Press **ⓘ** or **⏏**. You see the printer's IP address. For example,



3. Press **⏏** to print a network information label.

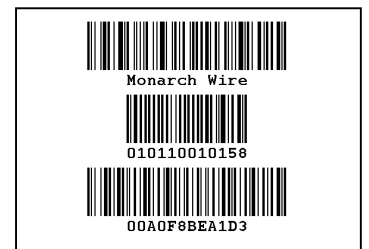

Sample Label

Printing Info

Do not use supply smaller than 2012 or information may print off the label.

1. From the RF Network (9460) or Network (9493) menu, select **Print Info**. Three wireless network information labels print.

The first label contains radio version information.

The second label contains the RF (wireless) settings, including the SSID, security, and signal strength.

The third label contains TCP/IP settings, including the IP address, boot method, etc.

2. Press the navigation button to return to the RF Network or Network menu.

Resetting the Radio

After you save the configuration, you must reset the radio before the changes take effect. When you select "Reset," the radio reinitializes.

Note: You may lose your current connection and application. Resetting the network may take up to one minute before you can access the wireless print server (radio).

3. From the RF Network or Network menu, select **Reset**. You may see:

RESET
Command Sent

4. For the 9460, press any navigation button to return to the RF Network. The 9493 returns to the Network menu automatically.

Monarch Print Server Status

MAC: 00-a0-f8-5f-72-0b
Printer Model: 9493SNP

Boot Ver : 1.0
Application:Peg3-1.20 (2008.06.10)

Label 1

Wireless Information

SSID: MON 123
Mode: INFRASTRUCTURE
Speed: 54 mbps
Security: Disabled
Sig. Strength: 51
Actual SSID: MON 123
Assoc. AP MAC: 00-a0-f8-aa-83-25

Label 2

TCP/IP

IP Address: 192.0.0.192
Subnet Mask: 255.255.255.0
Router: 192.0.192.0
(set manually)
Boot Method: STATIC
Boot Retries: 4
Timeout: 0 min
Keepalive: 1 min

Label 3

There are a variety of ways to configure and monitor the network printer. This chapter explains how to use NetManager, HP JetAdmin, HP Web JetAdmin, UNIX, or Sun Solaris.

See Chapter 4, “Using a Web Browser” to configure the network printer via your Browser. See Chapter 5, “Using the Sierra Sport Configurator” to configure the network printer via Avalanche software.

HP JetAdmin Utility

This HP Windows-based utility (works transparently with JetAdmin) can be downloaded from the HP Web site (www.hp.com).

Note: The print server does not appear in the list of configured servers unless TCP/IP or IPX is running on the computer.

HP Web JetAdmin Utility

This HP utility for Windows NT Advanced Server and Windows 2000 can be downloaded from the HP Web site (www.hp.com). Once it is installed, a web browser on any computer that has access to the Windows NT/2000 server may be used to access the print server.

Microsoft® Windows® Network Configuration

The print server includes the NetManager software for printing from Windows computers over an 802.11b/g wireless link. This software creates a network port on the Windows system, which acts like a normal parallel port. As a result, it works transparently with any standard Windows printer driver and application program. Since this software uses the industry-standard TCP/IP protocol, it can be used with IP routers and other IP-based equipment.

Additional Windows Configuration Methods

The print server is also compatible with other methods of printing from Windows. These include the Standard TCP/IP port option in Windows 2000/XP, and the LPR port option in Windows NT that are built into the operating system.

UNIX Network Configuration

The print server appears to the network as a UNIX host computer with a unique IP address running the line printer daemon (LPD) protocol. As a result, any host computer that supports the Berkeley remote-lpr command can spool jobs to the print server without the need for any special software on the host computer.

Note: Before configuring a UNIX print queue, the print server must have a valid IP address.

Berkeley UNIX Host Configuration

Berkeley UNIX host computers include Linux, Digital Equipment Corporation Digital UNIX, OSF/1, and ULTRIX; Compaq Tru64 UNIX; SunOS (not Solaris), SCO UNIX; and many others. Sun Solaris, HP/UX, IBM AIX users should skip to the appropriate sections later in this manual.

- ◆ Do not use the Linux X-Windows graphical user interface printer configuration utility, because it does not work with Monarch® print servers. Instead, Linux users should follow the configuration steps listed in this section.
- ◆ SCO UNIX users should use the `rlpconf` command to create a printer and automatically configure the `/etc/printcap` file (you will still need to edit the `/etc/hosts` file). Enter the print server's service name (PXRxxxxxx_P1) as the name of the printer and enter the name of the print server that you assigned in the `/etc/hosts` file as the remote host name; note that because this name must be unique for each printer, we recommend using the PXRxxxxxx_P1 service instead of the normal BINARY_P1 service.

1. Edit the `/etc/hosts` file: (or equivalent local host table). For example:

```
192.189.207.33    MonarchPrinter
```

2. Edit the `printcap` file: An example of a typical entry in the `printcap` file is:

```
MonarchPrinter:\
:lp=\
:rm=MonarchPrinter:\
:rp=BINARY_P1:\
:sd=/usr/spool/lpd/MonarchPrinter:
```

"MonarchPrinter" is the queuename.

"MonarchPrinter" matches the name in the `hosts` file.

"BINARY_P1" is the print server's service name.

Note: Use `TEXT_P1` instead of `BINARY_P1` for text files.

"sd" is the spool directory.

3. Create the spool directory: The `lpd` spool directory is usually located in the `/usr/spool` directory. To create a new spool directory, use the `mkdir` command; for example:

```
mkdir /usr/spool/lpd/MonarchPrinter
```

4. Print using the standard `lpr` command:

```
lpr -PMonarchPrinter filename
```

5. For AT&T based UNIX systems, such as SCO, use the standard `lp` command:

```
lp -dMonarchPrinter filename
```

Sun Solaris Configuration

To use a print server with Sun Solaris, first use the Host Manager in the `Admintool` utility to add the print server IP address and name to the `/etc/hosts` file.

1. Click **None** - Use `/etc` files on host.
2. Click **Apply**.
3. Click **Edit** and then **Add Host**.
4. Enter the print server name as the **Host Name** (this name is anything you want, but should not have an "_" character in it).
5. Enter the **IP address** and **Ethernet address** of the print server (the Ethernet address has the format `aa:bb:cc:dd:ee:ff`).
6. Select **Add** and then close the Host Manager windows.

7. Use the Printer Manager in the Admintool utility under Open Windows as follows:
 Select **Edit**
 Select **Add**
 Select **Add Access to Remote Printer**
 At the PrinterName prompt, type any name for the print queue
 At the Printer Server prompt, type:
 `name\!servicename`
 (for example, MonarchPrinter\!BINARY_P1), where:
name matches the print server name as entered in the host's table.
servicename is the print service name. For binary graphics files use the service BINARY_P1; for text files use the service TEXT_P1.
8. The Print Server OS is set to BSD (this is the default setting).
9. Select **Add**.
10. To print, use the standard lp command; for example:

```
lp -dMonarchPrinter filename
```

Notes:

- ◆ We recommend using the /etc/hosts file for the printer name rather than NIS or other name services.
- ◆ Due to a bug in the Sun lpd implementation on Solaris 2.4 and earlier releases, there may be problems printing very long print jobs.
 The workaround is to configure the print server as an HP JetDirect card using the HP JetAdmin for UNIX software.
- ◆ Solaris print queues can also be configured from the UNIX shell using the lpadmin command.

HP/UX Configuration

To configure a print server using HP/UX 10.x, use the same program and these steps:

1. When you get a list of options, select **Printers and Plotters**.
2. Select LP Spooler.
3. Select Printers and Plotters.
4. Select Actions and then Add Remote Printer/Plotter.
5. Enter any name as the **Printer Name** (this is the name of the print queue).
6. Enter the **IP address** of the print server as the Remote System Name.
7. Enter the print server service name (BINARY_P1 for binary files or TEXT_P1 for text files) as the Remote Printer Name.
8. Check the box next to Remote Printer is on BSD System.
9. You may accept the default values for the remaining items.
10. Click **OK** to configure the printer.
11. You should now be able to print using the lp -d command with the printer name.

Notes:

- ◆ The configuration for HP Distributed Print Services and for earlier versions of HP/UX is slightly different.
- ◆ The print server can also be configured as a JetDirect card using HP/UX. To do this, you will need the HP UNIX Host Printing Software (part of HP's JetAdmin for UNIX).

IBM AIX Configuration

To configure a print server on IBM AIX 4.x, use the SMIT program as follows:

1. Enter SMIT and select **Devices**.
2. Select Printer/plotter.
3. Select Manage remote printer subsystem.
4. Select Client services.
5. Select Remote printer queues.
6. Select **Add a remote queue**. Enter the following remote queue settings:
 - ◆ Name of queue to add (user selectable) Activate the queue (Yes).
 - ◆ Destination host (print server's IP address; or if you have configured the `/etc/hosts` file, use the name of the print server that you specified in that file).
 - ◆ Name of queue on remote printer BINARY_P1 for binary files or TEXT_P1 for text files).
 - ◆ Name of device to add (user selectable; for example lp0).
7. You should now be able to print using the normal `lp -d` command.

Note: The configuration for earlier versions of AIX is slightly different.
The print server can also be configured as a JetDirect card using AIX. To do this, refer to your AIX documentation.

Configuration on Other Systems

The print server can be used with any computer system that supports the LPR/LPD protocol or HP JetDirect (port 9100 is the default; however, it can be reconfigured). Refer to the system's documentation to configure LPR/LPD or JetDirect print queues.

USING A WEB BROWSER

4

You can configure and manage the printer and print server using your Web Browser: Microsoft® Internet Explorer, version 6.0, or greater or Netscape® Communicator, version 4.7 or greater or Mozilla Firefox®.

- Notes:**
- ◆ The screen pictures shown in this manual may not exactly match the software.
 - ◆ The recommended screen area resolution for your computer is 1024 x 768 pixels.
 - ◆ Before you begin, you need to know your printer's IP address. The printer should be turned on and ready to receive data.

It may take a minute or more before a wireless connection is associated between the print server and the access point. When the printer is connected, you see



The printer is ready to receive data.

Logging In

1. Start your Web browser.
2. Type in your printer's IP address and press **Enter**. For example, 192.0.0.192.

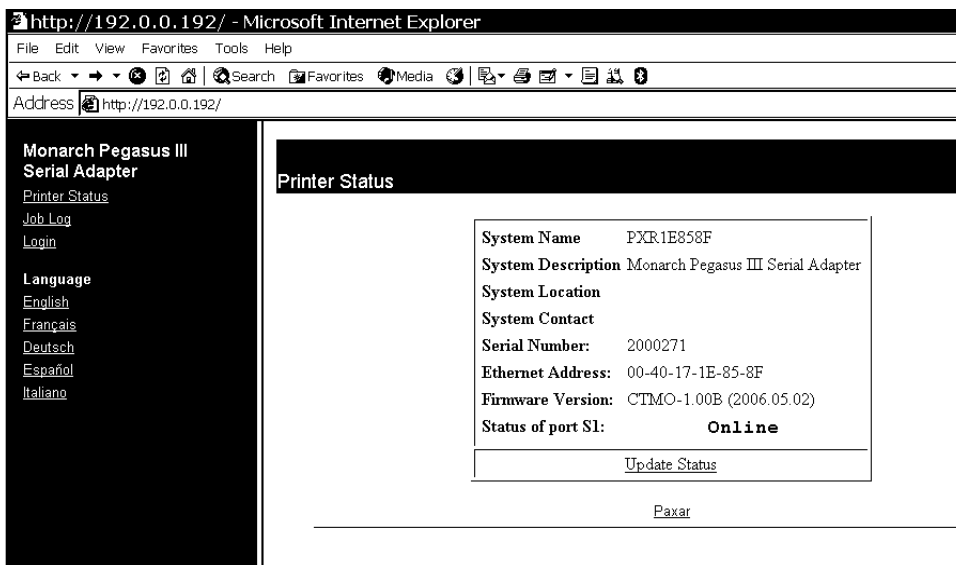

3. From the side menu, click **Login**.

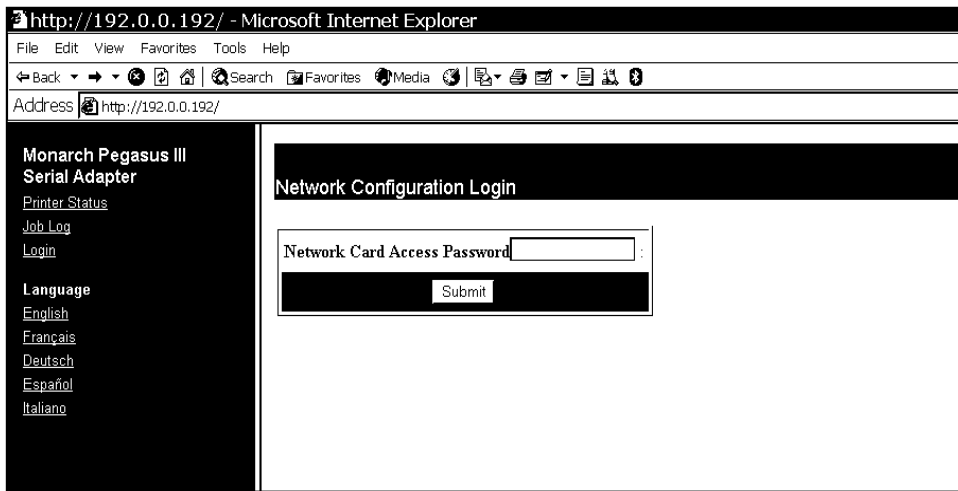

4. Type **access** for the password. To change the password, see “Setting the Network Card Access Password,” for more information.
The password is case-sensitive and saved in the printer’s flash memory.
5. Click **Submit**.

The Printer Status page appears with information about your printer, including printer name, description, firmware version and more. Use the following sections to configure the print server using your Web browser. Only configure the settings required for your network/printer.

Contacting Us

From the Printer Status page, click the Paxar link if you need to contact us.

Configuring the Server Settings

You can change the name, location, and other information for your server as well as set SNMP parameters, reset the server and restore server default settings.

1. From the side menu, click **Server Settings**.

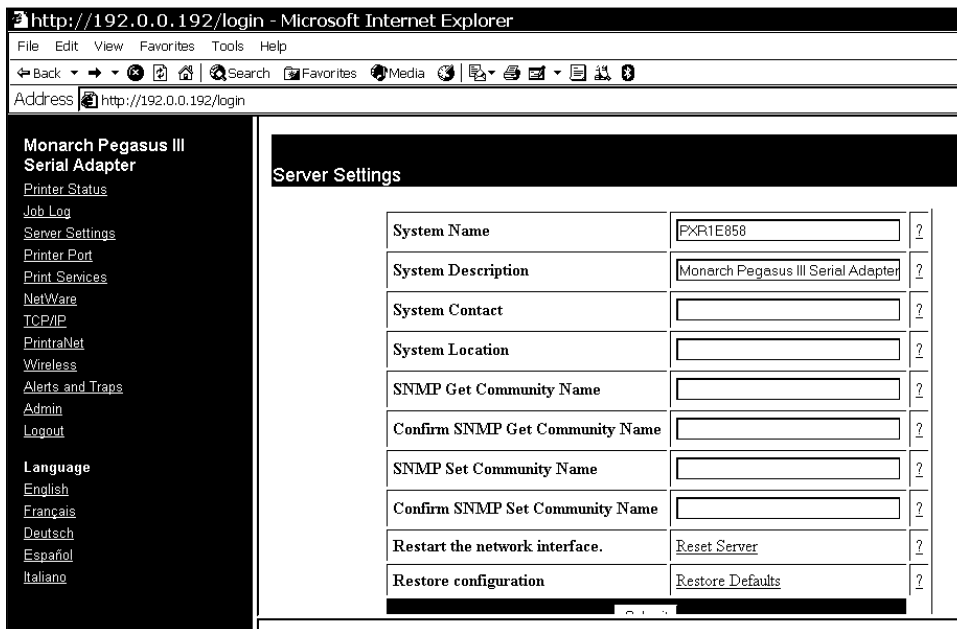

2. Enter your information and click **Submit**.
3. Click the reset link at the bottom of the screen. The Reset Server screen appears.
4. Click **Submit** and wait five seconds for the print server to reset.
Even though you submitted your changes, they do not take effect until you reset the print

server.

You must re-enter your access password to make any further changes to the printer settings.

Configuring the Print Port Settings

You can view available ports, port settings, cancel print jobs, and view the job log for each available port.

1. From the side menu, click **Printer Port**. The available ports are listed.
2. If more than one port is available, click the name of the port you want to modify. The Print Port Settings screen appears and displays your communication settings.

Port Name	S1
Job Queue	No jobs active
Status	Serial Device Online 1427 bytes transmitted, 56 bytes received 0 framing errors, 0 parity errors, 0 overrun errors
Port Type	Serial
Baud Rate	19200
Bits per character	8
Stop Bits	1
Parity	None

Note: Port Type, Baud Rate, Bits per character, Stop Bits, Parity, and Flow Control settings cannot be changed.

Configuring Print Services

You can configure the service ports if necessary.

1. From the side menu, click **Print Services**. The Configure Service screen appears.
2. Click the name of the service you want to modify from the available services listed.

Service Name	Port Name
PXR1E858F S1_A	S1
PXR1E858F S1_B	S1

The Configure Service page allows you to specify ports, determine network protocols, set filters and more.

3. Enter the new attributes and click **Submit**.

4. Click the reset link at the bottom of the screen. The Reset Server screen appears.
5. Click **Submit** and wait five seconds for the print server to reset.
Even though you submitted your changes, they do not take effect until you reset the print server.
You must re-enter your access password to make any further changes to the printer settings.

Setting Netware Parameters

You can enable Netware, set frame types, and passwords.

1. From the side menu, click **NetWare**.

2. Click the name of the enabled service to modify the NetWare parameters for that service. See “Configuring Print Services” for more information.
You can also change the network frame type (packet format), NetWare password, or disable NetWare.
3. When you are finished, click **Submit**.
4. Click the reset link at the bottom of the screen. The Reset Server screen appears.
5. Click **Submit** and wait five seconds for the print server to reset.
Even though you submitted your changes, they do not take effect until you reset the print server.
You must re-enter your access password to make any further changes to the printer settings.

Changing TCP/IP Settings

You can enable TCP/IP, select applications, set the IP Address, Subnet Mask, and more.

1. From the side menu, click **TCP/IP**.

TCP/IP	<input type="radio"/> Enable <input type="radio"/> Disable	
Enabled Services	PXR1E8\$8F \$1_A PXR1E8\$8F \$1_B	?
IP Address	IP Address <input type="text" value="192.0.0.192"/> Subnet Mask <input type="text" value="255.255.255.0"/> Gateway <input type="text" value="192.0.0.192"/> Boot Method <input type="text" value="AUTO"/> Boot Tries <input type="text" value="3"/>	?
RARP Boot Settings	<input type="checkbox"/> No Subnet Mask <input type="checkbox"/> No Gateway <input type="checkbox"/> Set address with ARP/Ping	?

2. Click the name of the enabled service to modify the TCP/IP parameters for that service. See “Configuring Print Services” for more information.
3. You can change protocols, assign an IP address, subnet mask, gateway and more.

Note: If you disable the IP protocol, you will not be able to configure the printer from your Web browser.

4. When you are finished, click **Submit**.
5. Click the reset link at the bottom of the screen. The Reset Server screen appears.
6. Click **Submit** and wait five seconds for the print server to reset.
Even though you submitted your changes, they do not take effect until you reset the print server.
You must re-enter your access password to make any further changes to the printer settings.

Configuring PrintraNet

You can enable POP3, set the Server Address, Mailbox Name, Password and more.

1. From the side menu, click **PrintraNet**.

Configure Printranet	
POP3	<input checked="" type="radio"/> Enable <input type="radio"/> Disable
POP3 Server Address	<input type="text" value="0.0.0.0"/> ?
Mailbox Name	<input type="text"/> ?
Mailbox Password	Enter new password <input type="text"/> ? Confirm new password <input type="text"/>
Poll Frequency	<input type="text" value="30"/> sec ?
Segmented Message Timeout	<input type="text" value="120"/> min ?
SMTP	<input checked="" type="radio"/> Enable <input type="radio"/> Disable
SMTP Server Address	<input type="text" value="0.0.0.0"/> ?

2. Enter the IP address of the POP3 or SMTP server on your network where internet print jobs are located.

You may also specify a mailbox name and password. For no password required, enter a single space in the field provided.

3. Click **Submit**.
4. Click the reset link at the bottom of the screen. The Reset Server screen appears.
5. Click **Submit** and wait five seconds for the print server to reset.
Even though you submitted your changes, they do not take effect until you reset the print server.
You must re-enter your access password to make any further changes to the printer settings.

Configuring Wireless Settings

You can change modes, specify your SSID, modify your channel (Ad-Hoc mode only), network speed, access point density, and more. You can also configure network security. See “Configuring Network Security” for more information.

1. From the side menu, click **Wireless**.

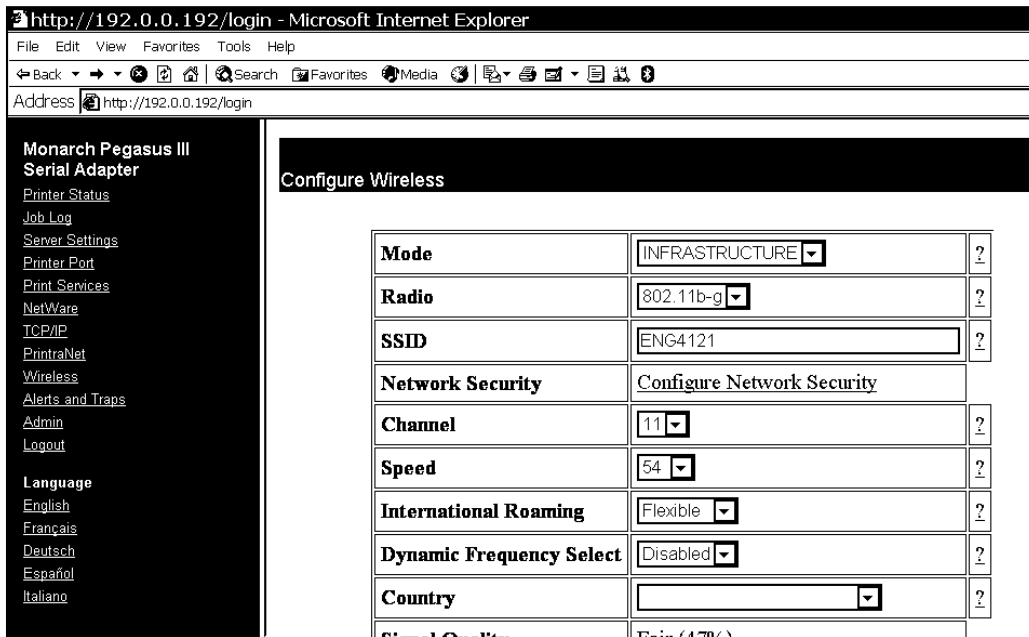

2. Select your information and click **Submit**.
3. Click the reset link at the bottom of the screen. The Reset Server screen appears.
4. Click **Submit** and wait five seconds for the print server to reset.
Even though you submitted your changes, they do not take effect until you reset the print server.
You must re-enter your access password to make any further changes to the printer settings.

Configuring Alerts and Traps

You can configure email alerts and SNMP IP Traps.

Email Alerts

To set an email alert when the printer goes offline, has a paper jam, or other error:

1. From the side menu, click **Alerts and Traps**.

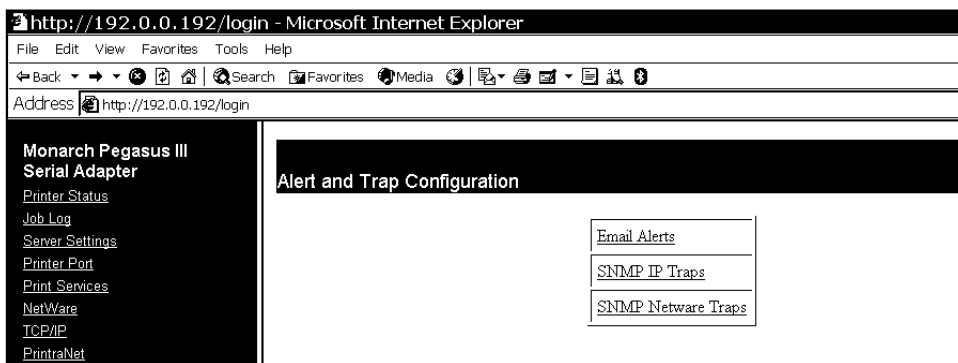

2. Click **Email Alerts** to setup the mail server and select users to receive messages about the printer's status.

The screenshot shows a web browser window with the address bar displaying 'http://192.0.0.192 /login - Microsoft Internet Explorer'. The page title is 'Monarch Pegasus III Serial Adapter'. A navigation menu on the left includes links for Printer Status, Job Log, Server Settings, Printer Port, Print Services, NetWare, TCP/IP, PrintNet, Wireless, Alerts and Traps, Admin, Logout, and Language (English, Français, Deutsch, Español, Italiano). The main content area is titled 'Email Alert Configuration' and contains the following fields:

SMTP Server Address	192.0.0.192
SMTP Server Port	25
Email Address 1	user@domain.com
Use on Port	<input checked="" type="checkbox"/> S1
Trigger Conditions	<input checked="" type="checkbox"/> On Line <input checked="" type="checkbox"/> Off Line <input type="checkbox"/> Toner Low <input checked="" type="checkbox"/> Paper Out <input checked="" type="checkbox"/> Paper Jam <input type="checkbox"/> Door Open <input checked="" type="checkbox"/> Printer Error

3. Enter your SMTP server, email address, server port, and the trigger conditions for an email alert. You can enter up to eight email addresses.

Note: The S1 port acts as a toggle switch to enable or disable the alerts. You must select S1 to enable the alerts.

4. Click **Submit**.
5. Click the reset link at the bottom of the screen. The Reset Server screen appears.
6. Click **Submit** and wait five seconds for the print server to reset. Even though you submitted your changes, they do not take effect until you reset the print server. You must re-enter your access password to make any further changes to the printer settings.

Receiving An Alert

When the printer goes offline, has a paper jam, or any other error that you selected notification for, a similar email appears in the specified User's inbox:

The text of the email follows:

From	Subject	Received
PXR1E858F@paxar.com	Alert #4: ERROR #754	Wed 9/29/...
PXR1E858F@paxar.com	Alert #1: Going Off-Line	Wed 9/29/...

Pegasus III Printer Alert

Prn IP: 192.0.0.192

Prn Display: Off-line

Prn MAC Addr: 10.10.1.1

Prn Location:

System Contact:

Please DO NOT REPLY to this message

Perform the appropriate action to correct the problem. Make sure the printer's display says "Ready" and shows the antenna icon after the problem is corrected.

SNMP IP Traps

You can configure the SNMP IP traps.

1. From the Alerts and Traps page, click **SNMP IP Traps**.
2. Enter a community name, IP address, and the trigger conditions for an email alert. You can

Trap Community	<input type="text" value="public"/>		
IP Address 1	<input type="text" value="192.0.0.192"/>	Port	<input type="text" value="162"/>
Use on Port	<input checked="" type="checkbox"/> S1		
Trigger Conditions	<input checked="" type="checkbox"/> On Line <input checked="" type="checkbox"/> Off Line <input type="checkbox"/> Toner Low <input checked="" type="checkbox"/> Paper Out <input checked="" type="checkbox"/> Paper Jam <input type="checkbox"/> Door Open <input checked="" type="checkbox"/> Printer Error		

enter up to eight IP addresses.

Note: The S1 port acts as a toggle switch to enable or disable the alerts. You must select S1 to enable the alerts.

3. Click **Submit**.
4. Click the reset link at the bottom of the screen. The Reset Server screen appears.
5. Click **Submit** and wait five seconds for the print server to reset. Even though you submitted your changes, they do not take effect until you reset the print server. You must re-enter your access password to make any further changes to the printer settings.

SNMP Netware Traps

You can configure the SNMP Netware traps.

1. From the Alerts and Traps screen, click **SNMP Netware Traps**.

SNMP Netware Trap Configuration	
Trap Community	<input type="text" value="public"/>
IPX Network Address 1	<input type="text" value="00000000"/>
IPX Node Address	<input type="text" value="000000000000"/>
Use on Port	<input type="checkbox"/> S1
Trigger Conditions	<input type="checkbox"/> On Line <input type="checkbox"/> Off Line <input type="checkbox"/> Toner Low <input type="checkbox"/> Paper Out <input type="checkbox"/> Paper Jam <input type="checkbox"/> Door Open <input type="checkbox"/> Printer Error

2. Enter a community name, IPX address, IPX Node address, and the trigger conditions for an email alert. You can enter up to four IPX addresses.

Note: The S1 port acts as a toggle switch to enable or disable the alerts. You must select S1 to enable the alerts.

3. Click **Submit**.
4. Click the reset link at the bottom of the screen. The Reset Server screen appears.
5. Click **Submit** and wait five seconds for the print server to reset. Even though you submitted your changes, they do not take effect until you reset the print server. You must re-enter your access password to make any further changes to the printer settings.

Changing the Passwords

1. You can change the network access password, network update password, configure network security, IP access or protocol, print a test page, or access the console from the Web Admin Configuration screen.
2. From the side menu, click **Admin**. The Web Admin Configuration screen appears.

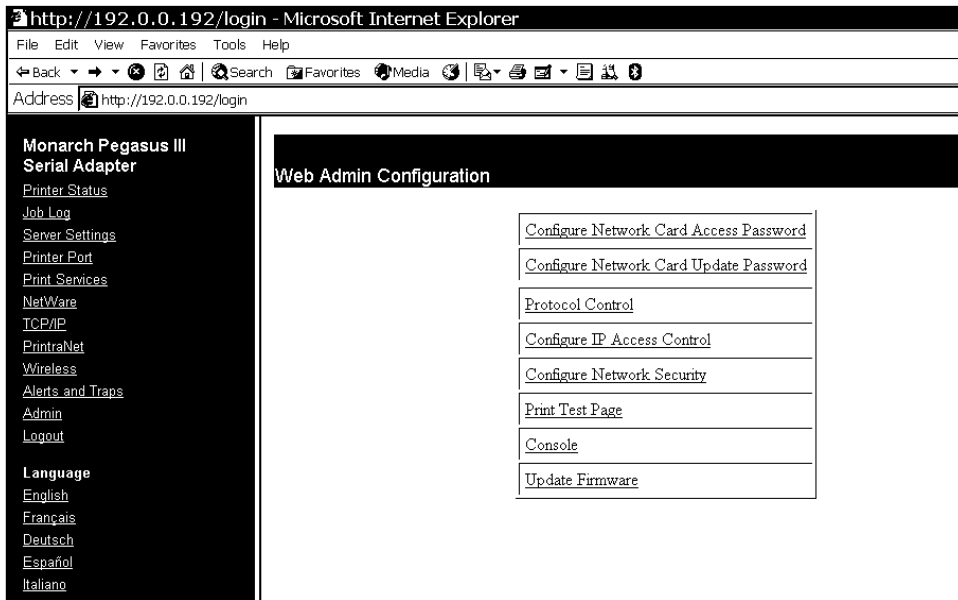

Setting the Network Card Access Password

When set, the network card access password allows you to view the Web browser and the remote console. The default is **access**. **The password is case-sensitive** and stored in the printer's flash memory.

Note: Make a note of the password if you change it. Changing the password also restricts access to Telnet sessions.

1. From the side menu, click **Admin**. The Web Admin Configuration screen appears.
2. Click Configure Network Card Access Password.

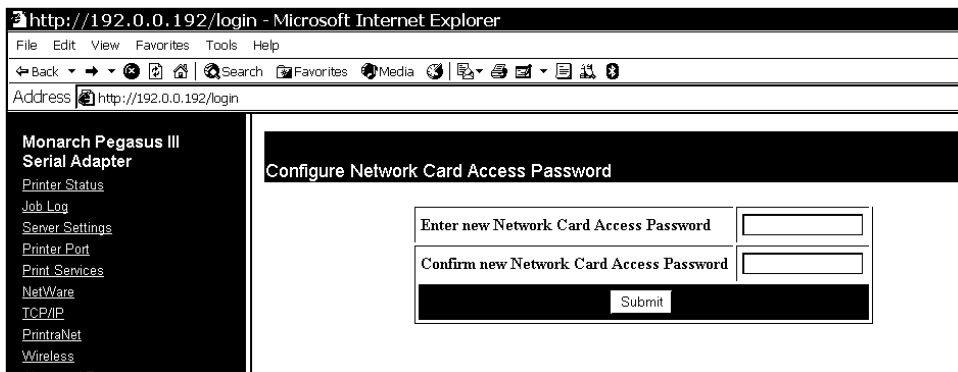

3. Enter a new network access password.
4. Retype the new password to confirm it.
5. Click Submit.

Setting the Network Card Update Password

When set, the network card update password allows you to change variables in the Web browser and the remote console.

1. From the side menu, click **Admin**. The Web Admin Configuration screen appears.
2. Click Configure Network Card Update Password.

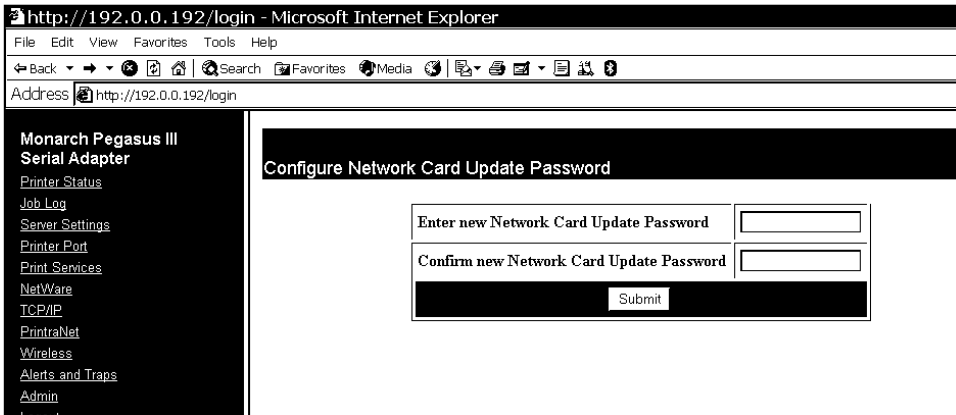

3. Enter a new network update password.
4. Retype the new password to confirm it.
5. Click **Submit**.

Configuring Network Protocols

1. Only configure the settings required for your network/printer. To enable or disable protocols:
2. From the side menu, click **Admin**. The Web Admin Configuration screen appears.
3. Click Protocol Control.

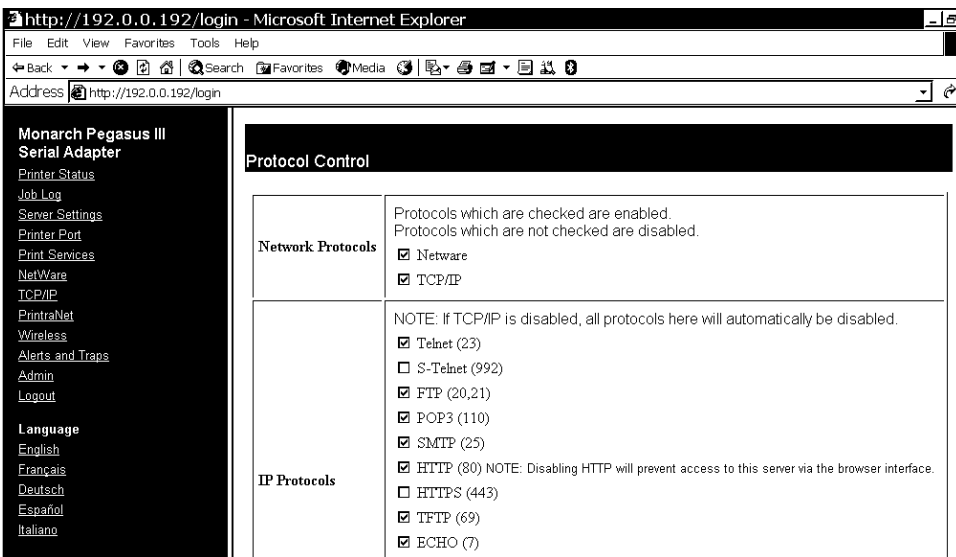

4. Enable or disable your network protocols and IP protocols.
- Note:** If you disable the TCP/IP protocol, all IP protocols are disabled automatically.
5. Click **Submit**.
 6. Click the reset link at the bottom of the screen. The Reset Server screen appears.
 7. Click **Submit** and wait five seconds for the print server to reset.
Even though you submitted your changes, they do not take effect until you reset the print server.

You must re-enter your access password to make any further changes to the printer settings.

Controlling IP Access

1. You can limit which remote hosts are able to access the printer by setting up an IP address range.
2. From the side menu, click **Admin**. The Web Admin Configuration screen appears.
3. Click **Configure IP Access Control**.

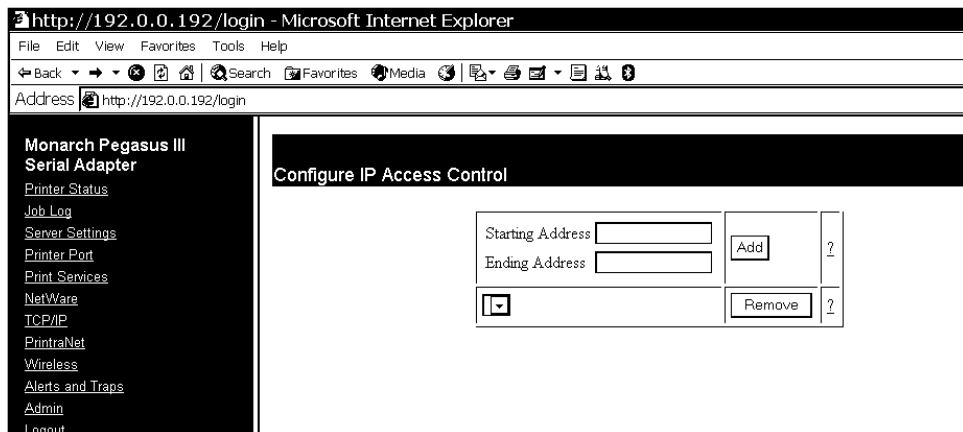

To Add Hosts:

You can specify the valid range of remote IP addresses.

1. Enter a range of remote IP addresses that are allowed access to the printer. Any requests from hosts outside this range are rejected.
2. Click **Add**.
3. Click the reset link at the bottom of the screen. The Reset Server screen appears.
4. Click **Submit** and wait five seconds for the print server to reset. Even though you submitted your changes, they do not take effect until you reset the print server. You must re-enter your access password to make any further changes to the printer settings.
5. The range of accepted IP addresses is listed in the drop-down menu.

To Remove Hosts

You can remove a range of remote IP addresses.

1. Select a range from the drop-down menu.
2. Click **Remove**.
3. Click the reset link at the bottom of the screen. The Reset Server screen appears.
4. Click **Submit** and wait five seconds for the print server to reset. Even though you submitted your changes, they do not take effect until you reset the print server. You must re-enter your access password to make any further changes to the printer settings.

Configuring Network Security

You can enable or disable network security, assign WEP keys, set up a User ID and password, select an authentication protocol, and more. See “Basic Security Configurations” for more information.

1. From the side menu, click **Admin**. The Web Admin Configuration screen appears.
2. Click Configure Network Security.

3. Assign the necessary security settings for your network. See “Basic Security Configurations” for more information.
4. Click **Submit**.
5. Click the reset link at the bottom of the screen. The Reset Server screen appears.
6. Click **Submit** and wait five seconds for the print server to reset.
Even though you submitted your changes, they do not take effect until you reset the print server.
You must re-enter your access password to make any further changes to the printer settings.

Printing a Test Page

You can use the Web browser to send a test page to the printer.

1. From the side menu, click **Admin**. The Web Admin Configuration screen appears.
2. Click Print Test Page.
3. Three wireless network information labels print. See Chapter 2, “Configuring the 802.11b/g and IP Settings” for more information on test labels.

Using the Console

The Custom Commands menu allows you to enter Telnet console commands.

1. From the side menu, click **Admin**. The Web Admin Configuration screen appears.
2. Click **Console**.

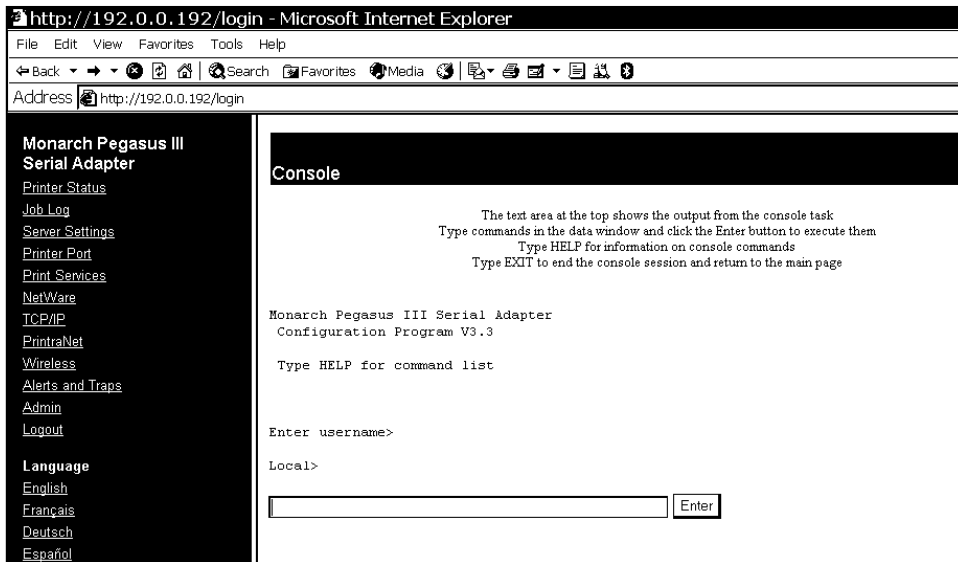

3. Enter a Telnet console command. See Chapter 6, “Telnet Console Commands,” for more information.
4. Click **Enter**. The results from a Telnet command appear.

Updating Firmware

You can update the printer’s firmware from your Web browser by connecting to a TFTP server, or browsing to the update file on your computer.

1. From the side menu, click **Admin**. The Web Admin Configuration screen appears.

2. Click Update Firmware.

http://192.0.0.192/login - Microsoft Internet Explorer

File Edit View Favorites Tools Help

Address http://192.0.0.192/login

**Monarch Pegasus III
Serial Adapter**

Printer Status
Job Log
Server Settings
Printer Port
Print Services
NetWare
TCP/IP
PrintraNet
Wireless
Alerts and Traps
Admin
Logout

Language
English
Français
Deutsch

Update Firmware

Load new firmware from a TFTP server

Firmware file name	<input type="text"/>	?
TFTP Server IP address	<input type="text"/>	?
<input type="button" value="Submit"/>		

Type in location or browse for new firmware file for this unit
NOTE: The firmware load may take several minutes. Please be patient.

Firmware file name	<input type="text"/>	<input type="button" value="Browse..."/>
<input type="button" value="Submit"/>		

3. The printer should be connected and ready to receive data.

To update from a TFTP server:

1. Type the TFTP Server IP address.
2. Type the relative pathname (relative to your TFTP server). Refer to your TFTP Server's documentation for more information about setting up and using the TFTP server.

Note: Depending on your TFTP server, you may only need the filename, not the entire path.

3. Click **Submit** to load the firmware. If you lose power while updating the firmware, call Service.

To update from a file on your computer:

1. Type the location of the file or click **Browse** and select the file location.
2. Click **Submit** to load the firmware. If you lose power while updating the firmware, call Service.

Note: **Do not** turn off the printer while it is updating firmware. It may take several minutes to complete.

Loading the Firmware

Early versions of the software may have menus which differ slightly from those listed below.

1. Run the UpdateIP utility from the Monarch® Documentation CD-ROM (TC9X00SWP), or download it from our Web site.
2. Select the update .bin file, print server, then click **Update, Start**.
3. If you are using TCP/IP to upgrade, select **TFTP PUT** from this host.
If you are upgrading using IPX/SPX on a NetWare network to upgrade, select **NetWare GET** from a server (If you are using NetWare to upgrade, you need to put the .bin firmware file in the LOGIN directory of the NetWare server). Click **OK**.
4. If you selected TFTP PUT from this host in step 3, enter the configuration password (default is **access**) and click **Browse** to find the .bin firmware file you downloaded. Click **Load**. The firmware on your print server will be upgraded to the new version.

If you selected NetWare GET from a server in step 3, enter the configuration password (default is **access**). Enter the name of the NetWare server where you saved the .bin file as the Host Name. Enter the name of the firmware file for File. Click **OK**. The firmware on your print server will be upgraded to the new version.

Basic Security Configurations

There are two main decisions to be made when choosing wireless security: encryption method and authentication protocol. The encryption method determines the algorithm used to encrypt the message. The authentication type specifies how users are identified and verified on a network. Is the device seeking connection what (and who) it claims to be?

Select an Encryption Method from the following table:

Encryption Method			
Type	Algorithm	Size (bits)	Description
WEP	RC4	64/128	This is the 64 or 128 bit WEP Key that must match other nodes' encryption keys in order to communicate. The user can only define 10 hex characters (40 bits) for 64 bit WEP or 26 characters (104 bits) for 128 bit WEP.
WPA	RC4	64/128	Improves on WEP by using TKIP* (Temporal Key Integrity Protocol), which dynamically changes the encryption key and MIC (Message Integrity Code), which replaces CRC.
WPA2	AES	128	Improves on WPA by replacing RC4 with AES (Advanced Encryption Standard) for encryption. The user can only define 26 characters (104 bits) for 128 bit WPA2.

* Dynamic WEP cannot be selected directly, so select 128 for the encryption mode and select an authentication mode from one of the following: LEAP, PEAP, EAP-FAST, TLS, or TTLS.

Authentication Protocol					
Type		RADIUS Server Protocol	User ID & Password	Certificate	Private Key Info File
Enterprise	LEAP	PAP or MSCHAPv2	Required	No	N/A
	PEAP*				N/A
	TLS			Optional*	Required*
	TTLS				N/A
	EAP-FAST			PAC*	N/A
Personal	PSK	N/A			

*PEAP This is only for server-side certificates.

*Optional Leaving the Certificate Root Key and the Certificate CN (common) names blank, no validation of the host certificate is performed. The values are set to "null" and all host certificates are accepted.

*Required The Print Server comes with a default Private Key Information File. You can either download that file from the print server and add it to the TLS authentication server, or overwrite a new one on the print server.

*PAC EAP-FAST does not use certificates to authenticate, but a PAC (Protected Access Credential), which is managed dynamically by the server. The PAC is distributed one at a time to the client manually or automatically. EAP-FAST has an optional feature called "auto-provisioning", which allows a client to receive the original PAC file wirelessly from the authentication server. However, this method is less secure and is not supported by Monarch® portable printers.

See the following table of acceptable combinations:

Authentication	Encryption	
	WEP	WPA, WPA (TKIP), WPA2
Open	Static	No
Shared		
PSK	Dynamic	Yes
LEAP		
PEAP		
EAP-FAST		
TLS*		
TTLS		

* Load the local key before enabling TLS.

USING THE SIERRA SPORT CONFIGURATOR

Use the Sierra Sport™ Configurator (SSC) with the Wavelink® Avalanche™ Management Console software and a Monarch 9460 printer (version 3.0 or greater firmware and version 1.4 or higher boot loader). Purchase the Avalanche software package from the Wavelink Corporation. Use Avalanche to manage mobile devices over networks (WAN or LAN).

Note: The Monarch 9493 printer does not support Avalanche at this time.

There are several key elements in the Avalanche System:

- ◆ **Avalanche Enabler** The 9460 printer has a built-in Avalanche Enabler that allows communications between the printer and the Avalanche agent once the printer is turned on. You can easily update the printer's firmware or configuration and receive status updates from the printer. Use Telnet console commands to disable the enabler, if necessary. The printer (with the enabler) is also referred to as a "client."
- ◆ **Avalanche Agent** The agent manages functions on the network (WAN or LAN) and stores the settings and software for the clients. You can have one or more agents throughout your network. The agent receives commands issued by the Management Console.
- ◆ **Avalanche Management Console** Use the Management Console to issue commands to the agents. Your System Administrator can view and manage all agents and clients on the network by scheduling updates, identifying client settings, configuring profiles, and checking the status (failure/success) of updates to each client on the network.

Download our .AVA package (SSCfgr.AVA) from our Web site. The package contains all the files you need to connect with Avalanche including the SSC software.

For information about using the Avalanche Management Console, refer to your Avalanche documentation. The following graphic shows how Avalanche works with the 9460 printer.

Files are transferred from the console to the agent through the WAN or LAN and onto the clients.

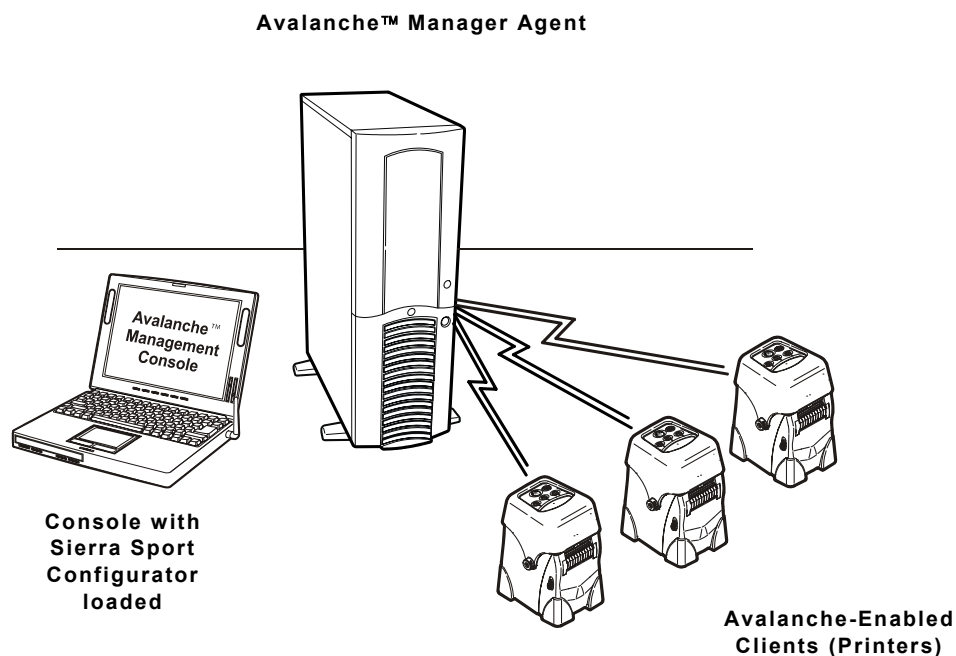

System Requirements

To use the Avalanche-enabled printer, you need the following:

- ◆ the Wavelink Avalanche Manager Agent (version 3.6.3 or greater) and Console (version 3.6.0 or greater)
- ◆ the AVA package (**SSCfg.AVA**)
- ◆ a wireless network

Before You Begin

1. Install the Avalanche Manager Agent and Console.
2. Open the Manager Agent.
3. Open the Avalanche Management Console.
4. Connect the Management Console to the agent.
5. Install the software package (**SSCfg.AVA**).
6. Select Configure Utility.
7. Click **Configure Package** to start the Sierra Sport Configurator.

When the application begins, the most recently-used session opens if one exists. Otherwise, a new session begins.

When the printer is turned on, it appears in the Avalanche Management Console as a client. Use the console to schedule the updates (new files or firmware) for each printer (client). Depending on your application, this could be done once a day or every time the printer is turned on.

Changing the Avalanche Directory

You need to specify the directory where Avalanche is installed, if the application does not automatically find it for you.

1. Select **Options** from the **File** menu.
2. Browse to the directory and select **OK**.
3. Click **OK** to return to the application.

You see the Wireless Settings tab.

Use the following instructions to configure the print server.

Configuring Wireless Settings

Use this tab to configure the wireless settings.

1. Specify the Basic Wireless settings including Mode, Radio, SSID, Channel, Speed, Access Point Density, International Roaming, Dynamic Frequency, Country and RTS Threshold.
2. Specify the Wireless Security and enter any **WEP Keys**, **Wireless Authentication**, or **Passwords** as required.

Configuring the Extended Security Settings

Use this tab to configure the extended security settings.

Specify the Certificate settings, including the **Root Key**, **Common Names**, **Organization Names**, and **Passphrases** as required.

Configuring the Print Server Settings

Use this tab to configure the server settings.

1. Specify the basic Print Server settings including the **System Name**, **Location**, **SNMP Community Name**, and **Power Level** as required.
2. Enable **Restart the Network Interface** to reinitialize the print server with the selected settings at the end of the script.
3. Enable **Restore Default Configuration** to restore all print server defaults *before* applying any other configuration settings.
4. Enter the Passwords for Read and Write Access.
5. Enter the Firmware Update File and TFTP Server IP Address if necessary.

Configuring Services

Use this tab to configure the services for TCP/IP and NetWare.

1. Enter the Service Settings including the **Filter**, **Priority**, and **TCP Port**.
2. Select the Protocol and NetWare Queue Server or Remote Server.
3. Specify the Control Strings for the Beginning and End of Jobs.

Configuring TCP/IP Settings

Use this tab to configure the TCP/IP settings.

1. Enter the various TCP/IP settings including **IP Address**, **Subnet Mask**, **Gateway**, **Boot Method**, **Boot Tries**, and **Timeouts** as required.
2. Select any **LPD** or **RARP** settings.
3. Enter the **DNS** settings.

Specifying the IP Access Range

Use this tab to specify a range of acceptable IP addresses and Subnet Masks.

1. Click **<<Add**.

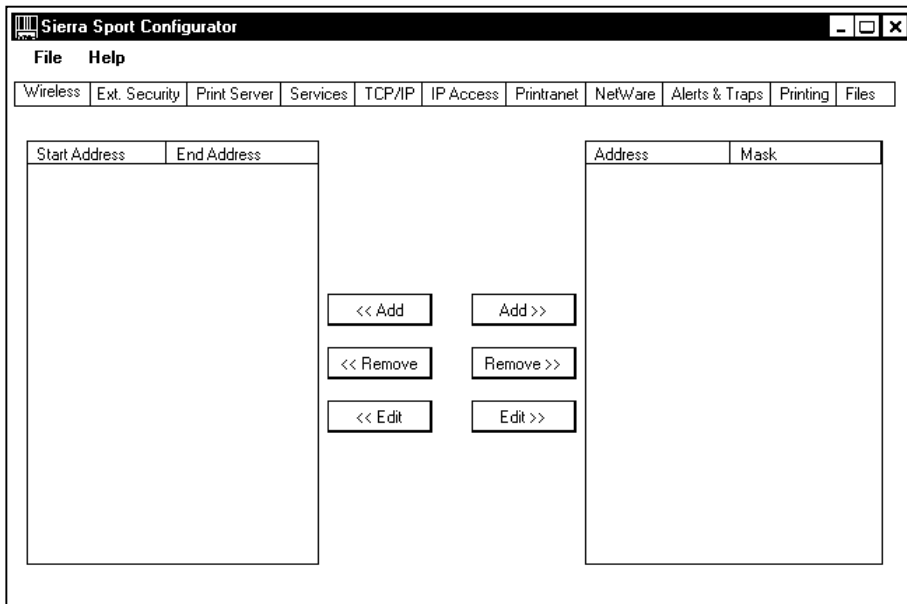

2. Enter the Starting Address.
3. Enter the Ending Address.
4. Click **OK** when finished.
5. Click **Add>>** to enter the Starting Address and Ending Address for the Subnet Mask.
6. Click **OK** when finished.

Configuring Printranet Settings

Use this tab to configure the Printranet settings including **POP3** and **SMTP**.

Configuring NetWare Settings

Use this tab to configure the NetWare settings including **Frame Type**, **Password**, and **Configure Bindery File Servers**.

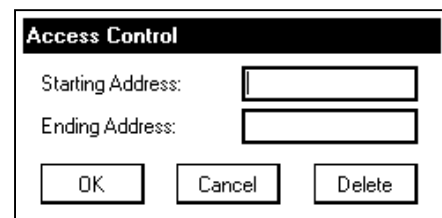

Setting Alerts and Traps

Use this tab to configure the email alerts and SNMP IP Traps.

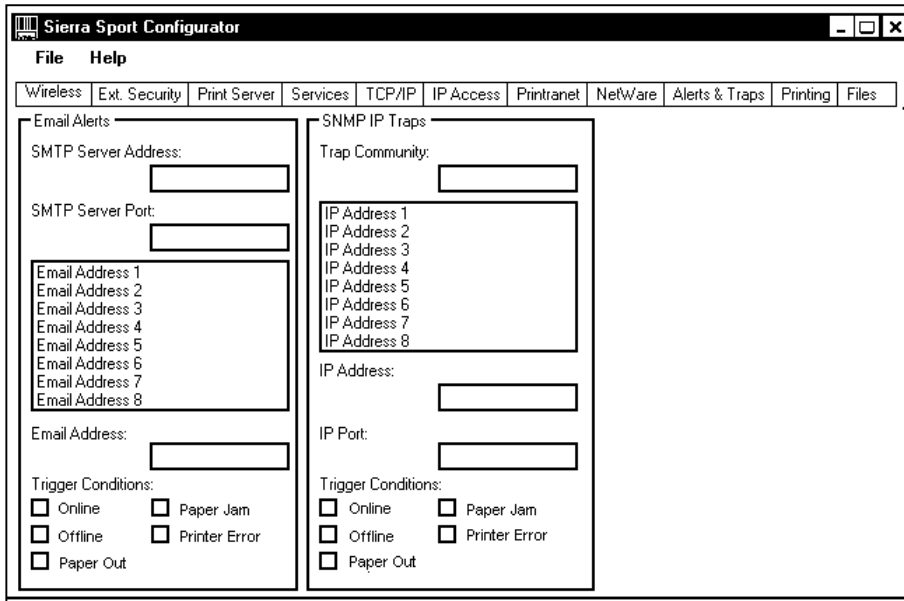

1. Specify the Email Alerts, including the **SMTP Server Address**, **SMTP Server Port**, enter the **Email Address** and select the **Trigger Conditions** for each email address.
2. Specify the SNMP IP Traps including the **Trap Community**. Enter the **IP Address** and **IP Port**. Select the **Trigger Conditions** for each IP address.

Configuring Printing Settings

Use this tab to configure the printer's supply settings, regional settings, and image adjustments.

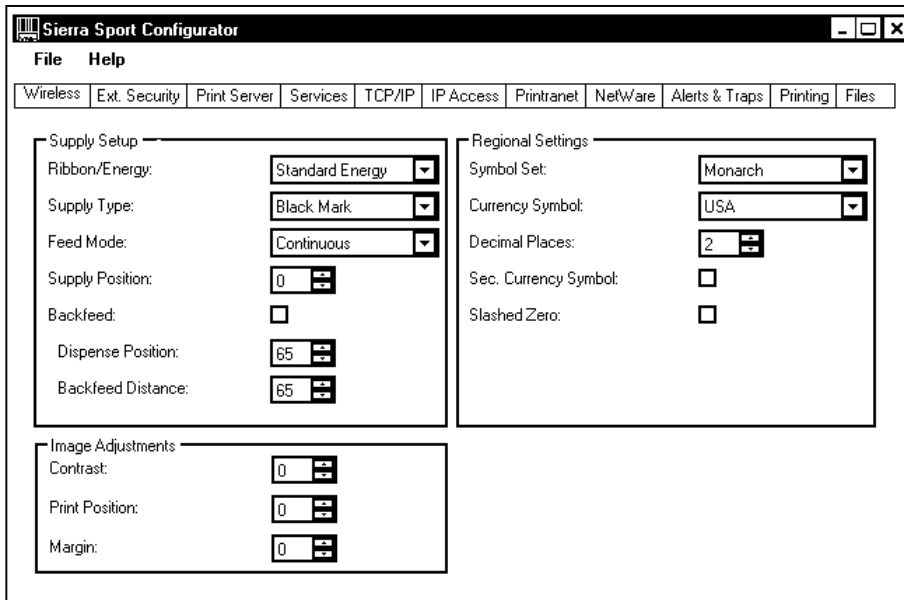

1. Enter any Supply Setup information including **Ribbon/Energy**, **Supply Type**, **Feed Mode**, and **Supply Position**.
2. Enter any Image Adjustments including **Contrast**, **Print Position**, and **Margin Position**.
3. Enter any Regional Settings including Symbol Set, Currency Symbol, Decimal Places, Secondary Currency Symbol, and whether to print a Slashed Zero.

Updating Files

Use this tab to update the printer's firmware or print server's firmware. Select additional MPCL files to send to the printer (fonts, graphics, etc.).

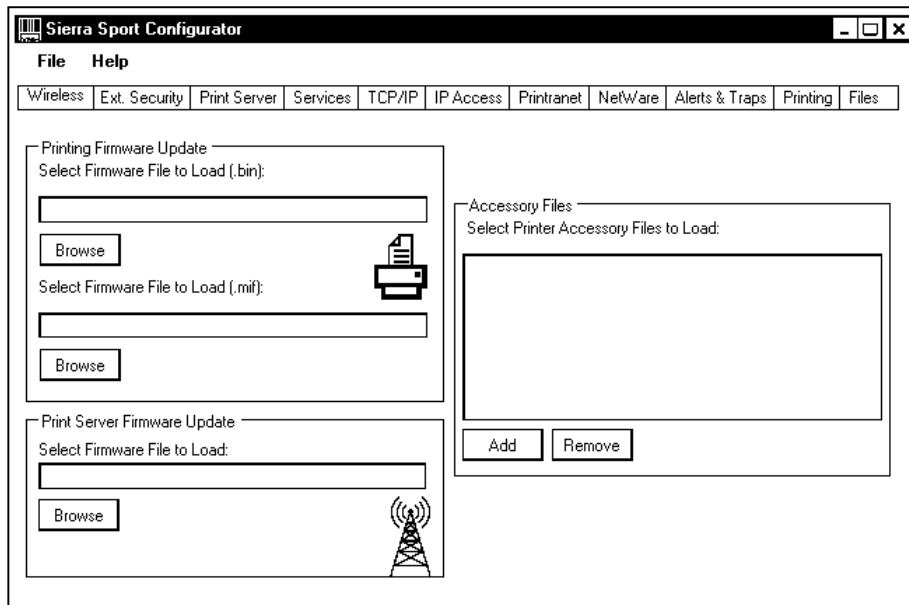

1. Select the binary Firmware File to Load.
2. Select the Monarch Initialization File (.mif) to Load.
3. Select the Print Server Firmware File to Load.
4. Enter any **Printer Accessory Files to Load**, including formats, fonts, graphics, check digits, etc.

Saving Changes

1. When you are done specifying the print server's settings, select **Write Configuration** from the **File** menu.
2. Exit the Sierra Sport Configurator.
The print server's configuration is set and ready for Avalanche to send to the printer.
3. Using the **Avalanche Management Console**, highlight the client and click **Update Now**, which updates the client immediately, instead of waiting until the scheduled time.

Creating Your Own Packages

We created the AVA package (**SSCfg.AVA**) to easily configure the print server and send updates to the printer. If you just need to update firmware, you can create your own package.

1. Use the **Avalanche Package Builder** to set up packages since everything is transferred to the printers via a package.

You may want to create separate packages for printer firmware updates or print server firmware update.

Packages include the following list of file extensions:

Extension	Description
.bin	Print Engine Firmware
.mif	Standard Monarch .mif file (Monarch Initialization file)
.pcl	MPCL data
.psb	Print Server Binary
.psc	Print Server Configuration Script
.asc	Authentication Server Certificate
.lcc	Local Client Certificate

2. Install the package.

Using the **Avalanche Management Console**, select the package, enable the package and then, send the package.

Use this chapter to configure the print server using Telnet. You must have a basic understanding of Telnet commands. For initial setup, do not use Telnet. Use auto-discover mode. Once you have the IP address, you can use Telnet or a Web browser. You can use Telnet if you do not have access to the NetManager software.

Note: The default port is Port 23.

To access Telnet console mode:

1. Start Telnet.
2. Press **Enter** (on your host) until you see the “#” prompt.
3. Type `access` as the password and press **Enter**. (`access` is the default password.)
4. Press **Enter** to by-pass the user name. You do not need to enter a username.

Note: The Telnet session times out after 10 minutes of inactivity.

Conventions

This section uses the following conventions:

KEYwords	Type the capitalized letters of each keyword instead of the whole keyword. Some keywords require more capitalized letters than others. For example, SEt KEYVAL RAdio
[options]	Mutually-exclusive options are included within square brackets and separated by a forward slash. Select only ONE of the options. For example, [DISable/STRICT/FLEXible]
<values>	Values are included within brackets. Values that contain spaces (multiple words) must be enclosed within quotation marks (“”). For example, SEt NW PW <value> SEt NW PW "Store 876"
n	Numeric digits are indicated by the letter (n). For example, SEt IP B0ot n SEt IP B0ot 5 SEt NW CHannel nn SEt NW CHannel 11

Settings

1. To view the current wireless settings, type `sh nw` (show network settings) and press **Enter**:

```
WiFi Mode = INFRASTRUCTURE
WiFi SSID: ABC1234
Speed = 54
International Roaming: Flexible
Dynamic Frequency Selection: Unsupported
Regulatory Domain = USI
WiFi FW Ver = 2.13.10.0 LMAC, 2.12.18.0 UMAC
AP density = LOW
Authentication type= OPEN SYSTEM
Encryption is Disabled
Local certificate loaded
AP MAC Address = 00 A0 F8 51 B4 FC
Signal Quality = Excellent (100%)
Connected to SSID ENG4121 on channel 11
```

2. To show the current IP settings, type `sh ip` (show TCP/IP settings) and press **Enter**.

```

IP is enabled
IP address      192.0.0.192      Boot tries      3
Subnet mask    255.255.0.0      Boot method     AUTO
IP Router      192.0.0.192      Max window      10240
  (via DHCP    192.0.0.192)
LPD banner     disabled         Timeout         0 min
LPD retries are disabled       Keepalive       1 min
Service        Port             TCP port
PXR1E8580_X1  X1              9100

```

3. To show the current Avalanche settings, type `sh ava` (show all Avalanche properties) and press **Enter**.

```

Console IP address: 192.0.0.192
Avalanche is Enabled
Packages installed:
SSCfsg: Revision 1
Properties set:
  OsVer = 3.0
  OsType = PHG2
  ProcessorType = MC68336GCAB20
  ProcessorRevision = 1F76K
  Processor = freescale
  Type = M09460
  ModelCode = 22
  ModelName = PXR1E859E
  NetVer = 1.14
  EnablerVer = 1.63
  RadioType = G
  CoreEnabler = 3

```

4. To change the SSID, type `set nw ssid testsystem` and press **Enter**.
5. To set the IP address, type `set ip ad 192.0.0.192` and press **Enter**.
6. To set the subnet mask, type `set ip sub 255.255.255.0` and press **Enter**.
7. Type `INIT` and press **Enter** to save the settings and initialize the unit.
8. Type `EXIT` to exit Telnet.

Help Commands

For help at any time, type “Help” and a list of available commands appears. The Help command builds on itself, because for each command you type, more details appear for each option.

Syntax: `help set`

<code>DEFAULT</code>	Set parameters to factory defaults
<code>PAssword <password></code>	Set console password
<code>PORt <name> ...</code>	Parameter for port <name>
<code>NWrk</code>	Network Parameters
<code>PROtect <password></code>	Set update password
<code>SERVER</code>	Server Parameters
<code>SERVICE <name></code>	Service Parameters
<code>SNMP</code>	SNMP Variables
<code>Avalanche</code>	Avalanche Parameters
<code>POWer</code>	Power Management
<code>SYSLog</code>	Syslog Parameters
<code>DNS</code>	DNS Parameters
<code>STRing n "..."</code>	BOT/EOT string
<code>IP</code>	LPD/TCP Parameters
<code>POP3</code>	POP3 Parameters
<code>SMTP</code>	SMTP Parameters
<code>NETWare</code>	Netware Parameters
<code>POWERON <delay-sec></code>	Power on delay

Displays a list of the available help commands for “Set.”

Note: For any command that uses SET, you can also use SHOW to view the current setting.

Syntax: help set ip

```

IP                LPD/TCP Parameters
Access [EN/DIS] aa.bb.cc.dd {Mask ee.ff.gg.hh}
ADdress aa.bb.cc.dd IP node address
ARP [EN/DIS]     IP set via ARP
BAnner [EN/DIS]  LPD banner printing
CHKSUM [EN/DIS]  IP receive checksum
BObt n           Number of DHCP/BOOTP tries
ECHO [EN/DIS]    TCP echo protocol
ENable/DISable   Enable or Disable IP Processing
FTIME [EN/DIS]   Timeout in seconds if enabled
FTP [EN/DIS]     FTP protocol
HTTTP [EN/DIS]   HTTP protocol
HTTTPS [EN/DIS]  HTTPS protocol
KEEpalive n      Keepalive interval (min)
LPD [EN/DIS]     LPD protocol
MEthod <type>    Set method of getting IP address
PIng aa.bb.cc.dd Test connection to IP host
PRObe [EN/DIS]   TCP connection probes
RANge [EN/ALL] aa.bb.cc.dd [MAx ee.ff.gg.hh]
RARp flags nn    1=no subnet, 2=no router, 3=neither
REtry [EN/DIS]   LPD retry continuation
ROuter aa.bb.cc.dd Default router address
SUBnet aa.bb.cc.dd Subnet mask
STELnet [EN/DIS] S-TELNET protocol
TCP [EN/DIS]     Raw TCP (9100) protocol
TELnet [EN/DIS]  TELNET protocol
TFTP [EN/DIS]    TFTP protocol
TImeout n        Inactivity timeout
TRAP n [ADDR/PORT/TRIG] TRAP configuration
WIndow nn        LPD/TCP maximum window size

```

Displays a list of the available help commands for "Set IP."

General Commands

From the list of commands, the brackets - [] indicate to pick one of the options listed.

CLear/DELeTe/PURge

Removes a specified parameter or configuration item.

CLear FATal

Deletes fatal error log.

CLear PORT <portname> JOB

Clears current entry in the print server's internal queue for the specified portname (P1 for the first parallel port).

CLear PROTECT

Sets the update password to "null."

CLear SERVEr STRing n

Removes BOT/EOT string.

EXIT/^D

Exits console mode.

HElp

Displays the list of available commands.

INitialize

Saves settings and resets unit.

SAVE

Saves configuration settings.

CHange/SEt/DEFine

Sets configuration items.

SEt DEFAULT

Sets print server to factory defaults.

SEt LOAD [EN/DIS]

Enables or disables firmware reload after exit.

SEt LOAD HOst <name>

Sets node name of boot host (NetWare firmware load).

SEt LOAD IP aa.bb.cc.dd

Sets IP address of load host (TCP/IP firmware load).

SEt LOAD SOftware <filename>

Sets print server's firmware filename to load.

SEt PASSword

Sets console password. The default password is **access**.

Note: The password is case-sensitive.

SEt PROtect <password>

Sets the update password.

SEt SERVER DEScription

Sets mode description to string displayed with SHOW SERVER command.

SEt SERVER NAME <name>

Sets server node name.

SEt SERVER SYSLog [EN/DIS]

Enables or disables access to the system log.

SHow FATAl

Shows the fatal error log.

SHow FREE

Shows the amount of available memory.

SHow LOAD

Shows the print server's firmware update parameters.

SHow SERVER

Shows the server parameters.

SHow SERVER COUNTERS

Shows the server statistics.

SHow SERVER QUeue

Shows the print server internal queue.

SHow SERVER SYSLog

Shows the system log, if access is enabled.

SHow TESTpage

Prints a test page.

SHow VERSION

Shows the server firmware version.

UNPROTECT

Allows the user to enter the update password (if one has been defined). Once the update password is entered correctly, SET commands can be used to modify the configuration until the console session is closed with EXIT.

ZERO

Zeros statistical counts.

Avalanche Console Commands

DELEte AVAlanche PROPerTy <name>

Removes an Avalanche property.

Note: This allows the user to delete system-defined properties. However, they are recreated on a restart.

SEt AVAlanche IP <ip address>

Sets the address of the Avalanche Agent.

SEt AVAlanche <EN/DIS>

Enables or disables the Avalanche Enabler.

SEt AVAlanche PROPerTy <name> <property value>

Adds an Avalanche property.

Port Commands

SEt PORT <name>

Sets the name of the communications port.

SHow PORT <name> STA

Shows the current port status.

802.11b/g Wireless Commands

CLear NW SSID

Clears the SSID, so the server connects to any access point.

SEt NW APDEN [LOW/MED/HI]

Sets 802.11b/g access point density.

SEt NW AUTHTRY n

Specifies the number of authentication tries the user is given.

SEt NW AUTHtype [OPEN/SHARED/TLS/TTLS/LEAP/PEAP/ EAP-FAST/PSK]

Sets the authentication type. See Chapter 4, "Using a Web Browser" for more information.

SEt NW CERTCN <name>

Sets the EAP common name. If no value is set (null), all host certificates are accepted.

SEt NW CERTCN2 <name>

Sets the second EAP common name. If no value is set (null), all host certificates are accepted.

SEt NW CERTEXP <value>

Sets the EAP certificate exponent value.

SEt NW CERTKEY <keyvalue>

Sets the EAP root key value.

SEt NW CHannel nn

Sets 802.11b/g wireless channel.

SEt NW ENC [Disable/64/128/WPA/WPA2/WPA2-WPA]

Sets the encryption mode. See Chapter 4, "Using a Web Browser" for more information.

SEt NW ID <userID>

Sets the authentication user ID. It may include the realm, separated with the at (“@”) character.

Country Code	Description	Country Code	Description	Country Code	Description
AL	ALBANIA	HN	HONDURAS	PS	PALESTINIAN TERRITORY
DZ	ALGERIA	HK	HONG KONG	PA	PANAMA
AR	ARGENTINA	HU	HUNGARY	PS	PALESTINIAN TERRITORY
AM	ARMENIA	IS	ICELAND	PE	PERU
AT	AUSTRIA	IN	INDIA	PL	POLAND
AU	AUSTRALIA	ID	INDONESIA	PH	PHILIPPINES
AZ	AZERBAIJAN	IR	IRAN, ISLAMIC REPUBLIC OF	PT	PORTUGAL
BH	BAHRAIN	IE	IRELAND	PR	PUERTO RICO
BY	BELARUS	IL	ISRAEL	QA	QATAR
BE	BELGIUM	IT	ITALY	RO	ROMANIA
BZ	BELIZE	JP	JAPAN	RU	RUSSIAN FEDERATION
BO	BOLIVIA	JO	JORDAN	SA	SAUDI ARABIA
BA	BOSNIA AND HERZEGOVINA	KZ	KAZAKHSTAN	SG	SINGAPORE
BR	BRAZIL	KE	KENYA	SK	SLOVAKIA
BN	BRUNEI DARUSSALAM	KP	KOREA, PEOPLE'S REPUBLIC	SI	SLOVENIA
BG	BULGARIA	KR	KOREA, REPUBLIC	ZA	SOUTH AFRICA
CA	CANADA	KW	KUWAIT	ES	SPAIN
CL	CHILE	LV	LATVIA	LK	SRI LANKA
CN	CHINA	LB	LEBANON	SE	SWEDEN
CO	COLUMBIA	LI	LIECHTENSTEIN	CH	SWITZERLAND
CR	COSTA RICA	LT	LITHUANIA	SY	SYRIAN ARAB REPUBLIC
HR	CROATIA	LU	LUXEMBOURG	TW	TAIWAN
CY	CYPRUS	MO	MACAO	TH	THAILAND
CZ	CZECH REPUBLIC	MK	MACEDONIA	TT	TRINIDAD AND TOBAGO
DK	DENMARK	MY	MALAYSIA	TN	TUNISIA
DO	DOMINICAN REPUBLIC	MT	MALTA	TR	TURKEY
EC	ECUADOR	MX	MEXICO	UA	UKRAINE
EG	EGYPT	MC	MONACO	AE	UNITED ARAB EMIRATES
SV	EL SALVADOR	MA	MOROCCO	GB	UNITED KINGDOM
EE	ESTONIA	NA	NAMIBIA	US	UNITED STATES
FI	FINLAND	NL	NETHERLANDS	UY	URUGUAY
FR	FRANCE	NZ	NEW ZEALAND	UZ	UZBEKISTAN
GE	GEORGIA	NO	NORWAY	VE	VENEZUELA
DE	GERMANY	OM	OMAN	VN	VIETNAM
GR	GREECE	PK	PAKISTAN	YE	YEMEN
GT	GUATEMALA	HK	HONG KONG	ZW	ZIMBABWE

SEt NW INAP [PAP/MSCHAP_V2]

Sets the EAP inner authentication protocol.

SEt NW IROAM [DISable/STRICT/FLEXible]

Controls whether the radio frequencies are set based on the radio configuration or from its access point. Disabled uses the radio defaults. Flexible uses access point settings if present, otherwise the radio defaults are used. Strict uses access point regulatory frequency information.

SEt NW KEY# <1/2/3/4>

Sets which WEP key number to use (default is 1).

SEt NW KEYVAL <WEPkey>

Sets WEP key value. Must be hexadecimal.

SEt NW MOde [INfra/ADhoc]

Sets 802.11b/g wireless mode to infrastructure or Ad-Hoc mode.

SEt NW PW <password>

Sets the password for 802.11b/g EAP authentication.

SEt NW REALM <realm>

Sets the realm portion of the 802.11b/g EAP authentication ID.

SEt NW RTS n

Sets the network RTS threshold. Range is 1-3000.

SEt NW REGDOMain <countrycode>

Sets the region of operation for the print server using the following table. The list of supported countries varies based on the radio type (802.11b or 802.11b/g).

SEt NW SPeed <1/2/5.5/6/9/11/12/18/24/36/48/54>

Sets 802.11b/g wireless speed in megabits per second (Mbps).

SEt NW SSid "<ssid>"

Sets 802.11b/g wireless SSID. Use quotes if there is a space in SSID. This is case sensitive.

SH NW STATS

Shows the network I/O statistics.

SEt NW WEP [DIS/64/128]

Sets wired equivalent privacy encryption level to disabled, 64-bit, or 128-bit.

SEt NW WPAGROUP [ENABLE/DISABLE]

Selects whether to use the WPA group key mode. When enabled, group keys are used for data link encryption.

SEt NW WPAPSK <psk-str>

Sets the WPA pre-shared key or pass-phrase. Use 64 hex characters for the PSK or 8-63 characters for the pass-phrase. This is only valid when authentication mode is WPA-PSK.

TCP/IP Commands

SEt IP [EN/DIS]

Selects whether to use IP-based protocols.

**SEt IP ACcess [EN] aa.bb.cc.dd
[Mask ee.ff.gg.hh]**

Allows or prevents specified IP address from accessing print server.

SEt IP AdDress

Sets IP address of print server.

SEt IP ARP [EN/DIS]

Selects whether to use an IP address with an ARP packet.

SEt IP BAnner [EN/DIS]

Sets printing of LPD job banners.

SEt IP BOot n

Sets number of retries (n) for DHCP, BOOTP, RARP

SEt IP CHKSUM [EN/DIS]

Enables or disables IP receive checksum.

SEt IP FTIme [EN/DIS]

Enables or disables fast timeout.

SEt IP FTP [EN/DIS]

Selects whether to use the FTP protocol.

SEt IP HTTP [EN/DIS]

Selects whether to use the HTTP protocol.

SEt IP KEepalive n

Sets keep alive interval (n) in minutes.

SEt IP LPD [EN/DIS]

Selects whether to use the LPD protocol.

SEt IP MEthod [AUTO/BOOTP/RARP/DHCP/STATIC]

Sets method of getting IP address.

SEt IP PIng aa.bb.cc.dd

Sends IP ping packets to test the host connection.

SEt IP PRObe [EN/DIS]

Enables or disables the TCP connection probe.

SEt IP RARp flags nn

0 Both

1 no subnet

2 no router

3 neither

Default (0) - IP address is set with subnet mask and router that is the same address as host.

SEt IP RANge [EN/DIS/ALL] aa.bb.cc.dd [MAx ee.ff.gg.hh]

Sets the valid range of IP addresses.

SEt IP REtry [EN/DIS]

Enables or disables LPD retry continuation

SEt IP ROuter aa.bb.cc.dd

Sets default Router/Gateway address (or access point).

SEt IP SUBnet aa.bb.cc.dd

Sets default subnet mask.

SEt IP TCP [EN/DIS]

Selects whether to use the raw TCP (port 9100) protocol.

SEt IP TELNET [EN/DIS]

Selects whether to use the Telnet protocol.

SEt IP TFTP [EN/DIS]

Selects whether to use the TFTP protocol.

SEt IP TImeout n

Sets timeout (n) in minutes.

SEt IP TRAP n ADDR <a.b.c.d[:e]>

Sets the destination IP address and optional port number to specify where to send the trap (n). If the port is not specified, it defaults to 162.

SEt IP TRAP n POrt n

Specifies the port that will be scanned for trigger conditions. The parameter is a bit mask.

SEt IP TRAP n TRIGger cccc

Specifies the trigger conditions (cccc) that send a trap (n). The parameter is a bit mask.

- 1 On line
- 2 Off line
- 4 (not used)
- 10 Paper out
- 20 Paper jam
- 8000 Printer error

SEt IP WInDow nn

Sets the LPD/TCP maximum window size (nn).

SNMP Commands

CLear SNMP CONtact <string>

Removes SNMP SysContact.

CLear SNMP LOcation <string>

Removes SNMP SysLocation.

SEt SNMP CONtact <string>

Sets SNMP SysContact.

SEt SNMP LOcation <string>

Sets SNMP SysLocation.

SEt SNMP GETCOMM <string>

Gets SNMP community.

SEt SNMP JETADmin [EN|DIS]

Selects whether to use the JetAdmin protocol.

SEt SNMP SETCOMM1 <string> or SET SNMP SETCOMM2 <string>

Sets SNMP community 1 or community 2 name.

Note: An incoming set request can use either name for comm1 or comm2.

SEt SNMP TRAPCOMM <string>

Sets SNMP trap community name.

Verify that the printer is operating properly, is online, and supplies are loaded correctly.



General Troubleshooting Information

Use the following information if your print server is not operating properly.

1. Verify that the printer is turned on.

2. Verify the print server is connected to the network.

The 9460 printer's display shows the <T> symbol when the printer is connected and ready to receive data.

The 9493 printer's display shows the  or the  symbol when the printer is connected and ready to receive data.

3. Print a test label. See Chapter 2, "Configuring the 802.11b/g and IP Settings" for more information.

Use 2-inch supply or some information may print off the label.

If a label does not print, check the printer's display to see if it shows a receiving status. Turn off the printer, wait fifteen seconds and then turn it back on.

4. On the test label, verify your IP and wireless settings.

Check the "Actual SSID" and the "Sig Strength". Is the actual SSID correct? Is the signal quality greater than zero? If the signal quality is 0, you lost connection with the access point. If it is very low, you may be experiencing interference or are very close to being out of range or an access point. A value of 100 is the best you can have for signal quality. You can probably operate at a minimum of 60, but the number of retries is likely to increase.

5. Telnet to the printer.

Note: After the print server has been reset, you may need to re-enable Telnet, or connect serially.

Once you have verified connectivity, Telnet to the printer. This gives you access to console operation of the printer. Press Enter (on your host) and enter `access` as the password. Press Enter to by-pass the user name. Once here, you have verified operation to the print server.

6. Ping the printer.

Pinging the printer tells you if it is "seen" on the network. If you cannot ping the printer, turn the printer off and then on. Then ping every device in the path to the printer - access points, routers, etc. Any device you cannot ping needs attention.

```
ping <ip address> (i.e. ping 192.0.0.192)
```

7. Verify connection to the data port by starting a Telnet session to the printer using port 9100 (i.e. Telnet aa.bb.cc.dd 9100).

Press `ctrl-E` on your keyboard. This sends an ENQ request. The printer responds with three characters. Depending upon the Telnet being used, you may not see the first character, as it is a hex 05 value. The other two characters are ASCII characters.

You see

```
A@
```

which means the printer is online and waiting. Alternatively, you can type

```
[J,2]
```

Note: The **J** must be capital.

The printer responds with {J,0,0,"", ""}.

No response means that the printer may have an open session to some other connection. Either terminate the other connection or turn off the printer and turn it back on.

Troubleshooting Wireless Configuration Problems

1. Your computer's wireless adapter and/or access point should be configured to match your print server.
2. The printer should be within range (up to 90 meters or 300 feet) of your computer and away from metal objects and other devices with radio signals (Bluetooth®, 2.4 GHz cordless phones, and microwaves).
3. Use infrastructure mode to connect through an access point. Use Ad-Hoc mode to connect without an access point.
4. To use WEP (Wired Equivalent Privacy) or other advanced security on your wireless network, temporarily disable the security on your computer in order to configure the print server. You may need to temporarily change the wireless mode of your computer to Ad-Hoc (802.11) mode to allow non-secure clients to communicate with each other.

Note: You may need to temporarily disable the security on your access point to set your computer to Ad-Hoc mode. When you are done configuring the print server, you can re-enable the security on your computer and change the wireless mode back if necessary. You can also use a serial (wired) connection to configure the print server.

5. To use encryption or password protect your wireless network, and your wireless adapter or access point normally uses a password or passphrase instead of WEP, it should allow you to enter 0x followed by a ten digit (for 40-bit or 64-bit WEP) or twenty-six digit (for 128-bit WEP) key in hexadecimal format (0-9 or A-F).
6. Change the RF channel (**Ad-Hoc mode only**) to correct intermittent connection problems or slow performance. This can be done in the NetManager Wireless Configuration screen. Change it to at least 3 channels lower or higher than any other wireless networks within range.

Troubleshooting Network Configuration

- ◆ To use TCP/IP, your computer and the print server should be on the same IP segment or can reach each other with a PING command from the host. The IP address you assign to the print server must be on the same logical network as your host computers.
- ◆ If your print server is set to Auto or DHCP for obtaining an IP address, the print server's IP address can change. Either configure your DHCP server to give the print server a permanent lease or configure the print server to be on a static address that does not conflict with any other address.

Technical Support

If these solutions do not work, call Service at the number listed on the back of this manual.

SPECIFICATIONS



Link Layer:	802.11b/g
Protocols:	TCP/IP Passthru BOOTP DHCP RARP LPD/LPR Telnet RSH or REMSH (remote shell) FTP SNMP NetWare HP Jet Admin

802.3 Specifications (9493™ only)

Communication Rate:	10 Mbps or 100 Mbps
----------------------------	---------------------

802.11b/g Specifications

Frequency:	2.4 GHz range, direct sequence
Communication Rate:	1, 2, 5.5, or 11, 12, 18, 24, 36, 48, or 54 Mbps
Channels	1 to 11
Mode:	Ad-Hoc or infrastructure
Encryption:	WEP 64 or WEP 128 WPA or WPA2
Authentication:	EAP-FAST LEAP PEAP TLS TTLS PSK

GLOSSARY



Absolute Pathname	The full path of a file, including the computer system and any directories or subdirectories. For example, c:\program files\monarch software\mpcl toolbox\9460.phu
Access Point	An interface between a wireless network and a wired network. Access points can be used with Ethernet or other communications to enable roaming throughout a facility.
Ad-Hoc Network/Mode	A wireless network composed of devices that contain a network interface card and no access point. Ad-Hoc mode is also called peer-to-peer (point-to-point) communications or BSS network. As long as the devices are in range and are on the same channel and SSID, they connect and communicate. Use this mode if a wireless infrastructure does not exist or where services are not required.
Authentication Method	Identifies users on a network, based on a username and password. There are two types: open and shared. Authentication protocols include LEAP, PEAP, TLS, TTLS, EAP-FAST, and PSK.
Auto Method	One of the available boot methods. Auto tries DHCP, BOOTP, and RARP, then sets to the last IP address used if the IP address is not automatically set using any of the previous methods.
BOOTP or Bootstrap Protocol	One of the available boot methods. It is a protocol used by devices that know their MAC address, but do not know their IP address. The device broadcasts its hardware address and the BOOTP server responds with the IP address for it. The network administrator must enter the MAC address in the BOOTP Config file to obtain the IP address from the server.
Boot Method	The wireless print server uses this method to obtain an IP address. Can be set to Auto, DHCP, BOOTP, RARP, or Static.
Boot Tries	The number of times the device tries to get an IP address from the server when using the BOOTP and DHCP methods.
BSS or Basic Service Set	A set of 802.11b/g devices operating as a fully connected wireless network.
BSSID	See <i>MAC Address</i> .
Channel or RF Channel	You can select which channel your network devices use to communicate. All devices must be on the same channel to communicate in Ad-Hoc mode. Other radio devices such as Bluetooth® wireless devices, microwave ovens, or 2.4-GHz cordless phones may operate/interfere if they are on the same channel as your network.
DHCP or Dynamic Host Configuration Protocol	One of the available boot methods. It is a protocol that issues IP addresses automatically within a specified range to devices (such as printers) when they are first turned on. The device keeps the IP address for a defined period of time set by your System Administrator; however, a device could have a different IP address every time it connects to the network.
EAP (Extensible Authentication Protocol)	Defines how to pass authentication information between the device and authentication server. The authentication is handled by the EAP type: FAST, TLS, TTLS, etc.
FAST (Flexible Authentication via Secure Tunneling)	Cisco Systems® developed this authentication protocol. It does not use certificates to authenticate, but a PAC (Protected Access Credential), which is managed dynamically by the server. The PAC is distributed one at a time to the client manually or automatically.
Gateway Infrastructure Mode	Allows connections (communications) between different subnets on a network. Requires an access point to communicate with other devices on the network. In infrastructure mode, wireless devices can communicate with each other or with a wired network.
IP Address	An Internet Protocol identifier for a device on a network. It consists of four 3-digit numeric fields, separated by periods. Each number can be zero to 255. An IP address has two components, the network address and the host address. Most company networks have ranges for their IP addresses.
LAN or Local Area Network	A computer network that connects personal computers, workstations, servers, and printers. This allows each user on the network the ability to share devices, such as printers, and communicate with each other via email, etc. LANs can be connected to each other by telephone lines or radio waves. See <i>WLAN</i> .

LEAP (Lightweight Extensible Authentication Protocol)	Cisco Systems® introduced this authentication protocol and provides mutual authentication with unique WEP keys for each user. New keys are issued based on a time limit. Changing the WEP key time limits provides additional security.
LPD/LPR	A printer protocol that uses TCP/IP to establish connections between printers on a network. Also known as Line Printer Daemon/Line Printer Remote.
MAC Address or Media Access Control	A hardware address (6-byte) that uniquely identifies each node of a network. The MAC address is set during manufacturing and does not change. Also, two Network Interface Cards (NIC) will not have the same value.
MSCHAPv2 (Challenge Handshake Authentication Protocol)	The Microsoft® version of CHAP. It is a three-way handshake protocol that is more secure than PAP. It provides mutual authentication between devices.
NIC or Network Interface Card	An adapter (board or card) that can be inserted into a device, so the device can be connected to a network. The NIC converts data from the device into the form transmitted or received from the network
Node	A processing location on a network. The location can be a workstation, computer, or printer. Each Node has a unique MAC address.
Open Authentication	This allows any device to authenticate and then attempt to communicate with the access point. Any wireless device can authenticate with the access point, but if WEP is used, the device can communicate only if its WEP keys match the access point's. There is no challenge that occurs, you either have the correct key or not when you communicate with the access point. By eliminating the challenge process, it actually makes this more secure than shared key authentication.
PAP (Password Authentication Protocol)	A simple authentication protocol used with PPP (Point-to-Point Protocol). It is a plain text password system, which is not very secure.
Pathname	The location of a particular file or directory that includes the full path to the needed filename or directory. This is a combination of path and filename.
PEAP (Protected Extensible Authentication Protocol)	Authenticates clients into a network using only server-side certificates, which makes implementing and administering a wireless LAN easier.
Ping	A way to determine if a device is accessible. It sends a packet to the specified address and waits for a reply.
Protocol	This is the way two devices transmit data between each other, including error checking, data compression, and how messages start and end.
PSK (Pre-Shared Key)	Authentication mode of WPA used in SOHO environments. The key value (or pass-phrase) is used for network authentication only (not data encryption). It does not use a RADIUS server like the other modes, but uses a shared key to provide the initial authentication with the access point or host.
RADIUS (Remote Authentication Dial-In Server)	This is an authentication server, such as the Cisco® ACS, Microsoft® IAS, etc.
RARP or Reverse Address Resolution Protocol	One of the available boot methods. The device sends an RARP request and the RARP server responds with an IP address. The device knows its MAC address and the server responds with the IP address for it.
Relative Pathname	The file or directory location on the user's system relative to the user's current location on the system (what directory the user is currently in). For example, c:\program files\monarch software\mpcl toolbox\9460.phu
Router Shared Authentication	Any device that forwards data along networks. Routers are located at gateways. The access point sends an unencrypted challenge text string to any device attempting to communicate with it. The device requesting authentication encrypts the challenge text and sends it back to the access point. If the challenge text is encrypted correctly, the access point allows the requesting device to authenticate. Both the unencrypted challenge and the encrypted challenge can be monitored; however, this leaves the access point open to attack. Because of this weakness, shared key authentication can be less secure than open authentication.

Signal Strength	A percentage (1 to 100) of the connection between the device and access point. If the signal strength is 0, there is no connection with the access point; 30 or less indicates you may be experiencing interference or close to being out of access point range, and below 50, printing performance could be affected. To improve the signal strength, try moving the printer closer to the access point and away from other radio devices such as Bluetooth® wireless devices, microwave ovens, or 2.4-GHz cordless phones.
Speed or Transmit Rate	Sets the maximum rate of communication between the devices on the network. It is also called transmit rate. The speeds are in megabits per second (Mbps) and include: 1, 2, 5.5, 11, 12, 18, 24, 36, 48, and 54.
SSID or Service Set Identifier	A unique identifier that must match for all nodes on a subnetwork to communicate with each other. It consists of up to 32 characters (any printable character, including spaces). If using the space character, it must be enclosed in quotation marks. It is case-sensitive.
Static Method	One of the available boot methods. Use static if your network uses fixed configuration. The IP address remains the same every time the device connects to the network.
Subnet	A portion of a network that shares a common address component. On TCP/IP networks, subnets are all devices with the same prefix. For example, all devices that start with 192.192.192 are part of the same subnet. Dividing a network into subnets is useful for both security and performance reasons.
Subnet Mask	A mask is used to determine what subnet an IP address belongs to. Companies often have ranges of IP addresses that can be described by one or more masks. For example, a mask of 255.255.255.0 allows variation in the last position only, because the first three positions are fixed.
Telnet	A Terminal Emulation program for TCP/IP networks that runs on your computer and connects your computer to a server on the network. You enter commands through the Telnet program and they run as if you were entering them directly on the server console.
TCP/IP	A way that two devices can transmit data between each other. TCP/IP (Transmission Control Protocol/ Internet Protocol) is generally the standard for transmitting data over a network.
TKIP (Temporal Key Integrity Protocol)	Changes the encryption keys regularly and has time limits before new keys are created. Changing the key periodically provides additional security.
TLS (Transport Layer Security)	A cryptographic protocol that uses client-side and server-side certificates to authenticate users on the Web. It can dynamically create user-based and session-based keys.
TTLS (Tunneled Transport Layer Security)	Provides certificate-based, server-side, mutual authentication of the client and network through an encrypted channel (or tunnel). It can dynamically create user-based and session-based keys.
Transmit Rate	See <i>Speed</i> .
WEP or Wired Equivalent Privacy	A security protocol for wireless local area networks. WEP was designed to provide the same level of security as that of a wired network, which is inherently more secure than a wireless network because wired networks are easily protected against unauthorized access. Wireless networks use radio waves to communicate and can be vulnerable to unauthorized users. WEP provides security by encrypting data over radio waves so that it is protected as it is transmitted. However, it has been found that WEP is not as secure as once believed. Note: If one part of a wireless network has WEP enabled, they all must have it enabled with the same key or they cannot communicate.
128 Bit / 64 Bit WEP Key	This is the 64 or 128 bit WEP key that must match other Nodes' encryption keys in order to communicate: 10 hex characters for 64 bit (40 user-specified characters), or 26 hex characters for 128 bit (104 user-specified characters). You must use the same key values for devices to communicate with each other.
WLAN or Wireless Local Area Network	A LAN that uses high-frequency radio waves to communicate between nodes, rather than telephone wires, etc.
WPA (Wi-Fi Protected Access)	A network security protocol that uses improved authentication and temporal keys. It was created to address the weaknesses of WEP encryption.
WPA2 (or IEEE 802.11i)	A network security protocol with stronger encryption than WPA. It was created to address the weaknesses of WEP encryption.

INDEX

A

- alerts
 - network, 4-7, 4-8, 4-9, 5-5
- authentication
 - EAP-FAST, 4-17
 - LEAP, 4-17
 - PEAP, 4-17
 - PSK, 4-17
 - TLS, 4-17
 - TTLS, 4-17
- authentication type, 4-17
- Avalanche, 5-1
- Avalanche system
 - requirements, 5-2

C

- command
 - general, 6-3
 - help, 6-2
 - SNMP, 6-9
 - TCP/IP, 6-7
 - wireless, 6-5
- configuration
 - label, 2-15
- console commands, 6-1

E

- EAP-FAST
 - authentication, 4-17
- encryption mode, 4-16
 - WPA, 4-16

F

- file
 - Monarch AVA, 5-2

H

- help commands, 6-2

I

- installing
 - software, 2-2

- IP Address
 - restrict, 5-4

L

- label
 - configuration, 2-15
- LEAP
 - authentication, 4-17
- login password, 4-1

M

- mode
 - encryption, 4-16
- Monarch AVA
 - file, 5-2

N

- network
 - alerts, 4-7, 4-8, 4-9, 5-5
 - protocols, 1-2

P

- page
 - label, 2-15
- password, 4-1
 - changing, 4-11, 4-12
 - setting, 4-11, 4-12
- PEAP
 - authentication, 4-17
- printer
 - settings, 2-1, 2-2, 2-3, 4-2, 4-3, 4-4, 4-6, 4-12, 4-13
 - setup, 5-5
- protocols, 1-2
- PSK
 - authentication, 4-17

R

- requirements
 - Avalanche system, 5-2
 - system, 1-2
- restrict
 - IP addresses, 5-4
 - Subnet Masks, 5-4
- RF network menu
 - setup, 2-3

S

- security, 4-13
 - settings, 4-13
- serial cable
 - setup, 2-1, 2-2
- server
 - settings, 4-2, 4-3, 4-4, 4-6, 4-12, 4-13, 5-3
- setting
 - password, 4-11, 4-12
- settings
 - printer, 2-1, 2-2, 2-3, 4-2, 4-3, 4-4, 4-6, 4-12, 4-13
 - security, 4-13
 - server, 4-2, 4-3, 4-4, 4-6, 4-12, 4-13, 5-3
 - SNMP, 4-9, 4-10
 - TCPIP, 4-5, 5-4
 - wireless, 4-7, 5-3
- setup
 - network, 4-7, 4-9, 4-10
 - printer, 2-1, 2-2, 2-3, 4-2, 4-3, 4-4, 4-6, 4-12, 4-13, 5-5
 - RF network menu, 2-3
 - serial cable, 2-1, 2-2
 - wireless, 4-7, 5-3
- SNMP
 - commands, 6-9
 - settings, 4-9, 4-10
- SNMP IP traps, 5-5

- software
 - installing, 2-2
- Subnet Mask
 - restrict, 5-4
- system
 - requirements, 1-2

T

- TCP/IP
 - commands, 6-7
- TCPIP
 - settings, 4-5, 5-4
- Telnet
 - commands, 6-1, 6-2, 6-5
- test
 - label, 2-15
- TLS
 - authentication, 4-17
- TTLS
 - authentication, 4-17
- type
 - authentication, 4-17

W

- Wavelink
 - Avalanche, 5-1
- wireless
 - settings, 4-7, 5-3
 - wireless commands, 6-5
- WPA
 - encryption mode, 4-16



Avery Dennison Printer Systems Division
170 Monarch Lane
Miamisburg, OH 45342

1-800-543-6650 (In the U.S.A.)
1-800-387-4740 (In Canada)
www.monarch.com

