



# Eclipse

---

User Manual

Version 8.04.02

260-668066-001



# Copyright & Terms of Use

---

## July 2018

This documentation incorporates features and functions provided with Eclipse User Manual, version 8.04.02.

## Copyright © 2018 by Aviat Networks, Inc.

All rights reserved.

No part of this publication may be reproduced, transmitted, transcribed, stored in a retrieval system, or translated into any language or computer language, in any form or by any means, electronic, magnetic, optical, chemical, manual, or otherwise, without the prior written permission of Aviat Networks Inc.

To request permission, contact [techpubs@daviatnet.com](mailto:techpubs@daviatnet.com).

## Warranty

Aviat Networks makes no representation or warranties with respect to the contents hereof and specifically disclaims any implied warranties or merchantability or fitness for any particular purpose.

Further, Aviat Networks reserves the right to revise this publication and to make changes from time to time in the content hereof without obligation of Aviat Networks to notify any person of such revision or changes.

## Safety Recommendations

The following safety recommendations must be considered to avoid injuries to persons and/or damage to the equipment:

1. *Installation and Service Personnel:* Installation and service must be carried out by authorized personnel who have the technical training and experience necessary to be aware of any hazardous operations during installation and service, and of measures to avoid any danger to themselves, to any other personnel, and to the equipment.
2. *Access to the Equipment:* Access to the equipment in use must be restricted to service personnel only.
3. *Safety Norms:* Recommended safety norms are detailed in the Health and Safety sections of the Eclipse User Manual.
4. *Service Personnel Skill:* Service personnel must have received adequate technical training on telecommunications and in particular on the equipment and capabilities this addendum refers to.

## Trademarks

All trademarks are the property of their respective owners.

**WARNING**

Making adjustments and/or modifications to this equipment that are not in accordance with the provisions of this instruction manual or other supplementary documentation may result in personal injury or damage to the equipment, and may void the equipment warranty.

**AVERTISSEMENT**

Tout réglage ou modification faits à cet équipement hors du cadre édicté par ce guide d'utilisation ou par toute autre documentation supplémentaire pourraient causer des blessures ou endommager l'équipement et peut entraîner l'annulation de sa garantie.

**WARNUNG**

Die an diesen Geräten gemachte Einstellungen und/oder Änderungen, welche nicht gemäß dieser Bedienungsanleitung, oder gemäß anderen zusätzlichen Anleitungen, ausgeführt werden, können Verletzungen oder Materialschäden zur Folge haben und eventuell die Garantie ungültig machen.

**ATENCIÓN**

Llevar a cabo ajustamientos y/o modificaciones a este equipo, sin seguir las instrucciones provistas por este manual u otro documento adicional, podría resultar en lesiones a su persona o daños al equipo, y anular la garantía de este último.

**警告**

不按该说明书有关条例或其它补充文件对该设备所做的调整和/或改型可能会引起人身伤害或损坏设备，并且设备保修也将失效。

# Aviat Networks Technical Support

## Service and Technical Support:

For customer service and technical support, contact one of the regional Technical Help Desks listed below.

Americas Technical Help Desk	EMEA Technical Help Desk	Asia Pacific Technical Help Desk
Aviat Networks, Inc. San Antonio, TX U.S.A.	Aviat Networks Blantyre, Glasgow, Scotland G72 0FB United Kingdom	Aviat Networks Clark Freeport Zone Philippines 2023
<b>Phone:</b> +1 210 526 6345 <b>Toll Free (USA):</b> +1 800 227 8332 <b>Fax:</b> +1 210 526 6315	<b>Phone:</b> +1 210 526 6345 <b>Fax:</b> +44 16 9871 7204 (English) +33 1 5552 8012 (French)	<b>Phone:</b> +1 210 526 6345 <b>Fax:</b> +63 45 599 5196
<b>Email:</b> <a href="mailto:TAC.AM@aviatnet.com">TAC.AM@aviatnet.com</a>	<b>Email:</b> <a href="mailto:TAC.EMEA@aviatnet.com">TAC.EMEA@aviatnet.com</a>	<b>Email:</b> <a href="mailto:TAC.APAC@aviatnet.com">TAC.APAC@aviatnet.com</a>

## Global Support Hotline: +1 210 526 6345

Call this phone number for support from anywhere in the world. Aviat Networks' Global Support Hotline is available 24 hours a day, 7 days a week, providing uninterrupted support for all our customers.

When you call our Global Support Hotline:

- You will be greeted by an automated response that will ask you for your PIN#. Request a PIN# here: <http://aviatnetworks.com/contact-us/technical-assistance/pin-request-form/>.
- As soon as you enter your PIN#, you will be transferred to our Global Technical Helpdesk that will assist you with your technical issue.
- If you do not have a PIN# your call will be answered by our Support Assurance Desk. Your call will be supported and prioritized accordingly.

Or you can contact your local Aviat Networks office. Contact information is available on our website at: <http://www.aviatnetworks.com/services/customer-support/technical-assistance/>

## Sales and Sales Support:

For sales information, contact one of the Aviat Networks headquarters, or find your regional sales office at: [HTTP://WWW.AVIATNETWORKS.COM/](http://www.aviatnetworks.com/).

<b>Corporate Headquarters</b> <b>California, USA</b>	<b>International Headquarters</b> <b>Singapore</b>
Aviat Networks, Inc. 860 N. McCarthy Blvd., Suite 200 Milpitas, CA 95035 U.S.A.  <b>Phone:</b> + 1 408 941 7100 <b>Fax:</b> + 1 408 941 7110 <b>Toll Free for Sales Inquiries:</b> + 1 888 478 9669	Aviat Networks (S) Pte. Ltd. 51 Changi Business Park Central 2 #04-10 The Signature Singapore 486066  <b>Phone:</b> + 65 6496 0900 <b>Fax:</b> + 65 6496 0999> <b>Sales Inquiries:</b> +1-321-674-4252

# Product Compliance Notes

---

Eclipse EMC testing was completed using screened cable; if any other type of cable is used, it may violate compliance.

Eclipse is a Class A product. In a domestic environment this product may cause radio interference in which case the user may be required to take adequate measures. This equipment is intended to be used exclusively in telecommunications centers.

## Regulatory Information for 5.8 GHz Band

### Eclipse IRU 600

The following regulatory information applies to license-free operation on the 5.8 GHz band of IRU 600v2, IRU 600v3 and IRU 600v4.

## FCC Notices

### IRU 600v2/v3

- IRU 600, 5.8GHz, must be professionally installed and maintained.
- This equipment has been tested and found to comply with the limits for a Class A digital device, pursuant to Part 15 of the FCC rules. These limits are designed to provide reasonable protection against harmful interference when the equipment is operated in a commercial environment. This equipment generates, uses and can radiate radio frequency energy and, if not installed and used in accordance with the instruction manual, may cause harmful interference to radio communications. Operation of this equipment in a residential environment is likely to cause harmful interference in which case the user will be required to correct the interference at their own expense.
- IRU 600, 5.8GHz, is compliant with the relevant parts of FCC CFR47, Part 15.407.
- To ensure compliance with the FCC RF exposure requirements, a minimum distance of 18 meters must be maintained between the antenna and any persons whilst the unit is operational. This calculation is based on the maximum conducted power and maximum antenna gain.
- IRU600, 5.8GHz, has been certified for use with a parabolic antenna with a maximum gain of 45.9dBi or a flat panel antenna with a maximum gain of 28dBi.
- The filters and software provided with this product allow for transmission only in the frequency range 5725 – 5850 MHz to ensure compliance with Part 15.407.
- According to the conducted power limit in FCC CFR 47, Part 15.407, the power for this device has been limited to 1W (30dBm) at the antenna port.
- FCC CFR47, Part 15.407 excludes the use of point-to-multipoint systems,

omnidirectional applications and multiple co-located intentional radiators. This system is only for fixed, point-to-point operation.

#### **IRU 600v4**

- IRU 600 , 5.8GHz, must be professionally installed and maintained.
- This equipment has been tested and found to comply with the limits for a Class A digital device, pursuant to Part 15 of the FCC rules. These limits are designed to provide reasonable protection against harmful interference when the equipment is operated in a commercial environment. This equipment generates, uses and can radiate radio frequency energy and, if not installed and used in accordance with the instruction manual, may cause harmful interference to radio communications. Operation of this equipment in a residential environment is likely to cause harmful interference in which case the user will be required to correct the interference at their own expense.
- IRU 600 , 5.8GHz, is compliant with the relevant parts of FCC CFR47, Part 15.407.
- To ensure compliance with the FCC RF exposure requirements, a minimum distance of 18 meters must be maintained between the antenna and any persons whilst the unit is operational. This calculation is based on the maximum conducted power and maximum antenna gain.
- IRU 600, 5.8GHz, has been certified for use with a parabolic or a flat panel antenna with a maximum gain of 43dBi.
- The filters and software provided with this product allow for transmission only in the frequency range 5725 – 5850 MHz to ensure compliance with Part 15.407. The minimum transmit frequency settable in software is 5742.5MHz and the maximum settable transmit frequency is 5832.5MHz.
- According to the conducted power limit in FCC CFR 47, Part 15.407, the power for this device has been limited to 1W (30dBm) at the antenna port.
- FCC CFR47, Part 15.407 excludes the use of point-to-multipoint systems, omnidirectional applications and multiple co-located intentional radiators. This system is only for fixed, point-to-point operation.
- This device complies with Part 15 of the FCC Rules. Operation is subject to the following two conditions:
  - (1) this device may not cause harmful interference, and
  - (2) this device must accept any interference received, including interference that may cause undesired operation.
- No changes shall be made to the equipment without the manufacturer's permission as this may void the user's authority to operate the equipment.

### **ISED (Canada) Notices**

#### **IRU 600v2/v3**

- IRU600, 5.8GHz, must be professionally installed and maintained.
- IRU600, 5.8GHz, is compliant with Industry Canada RSS-210.



- To ensure compliance with the Industry Canada RF exposure requirements in RSS-102, a minimum distance of 18 meters must be maintained between the antenna and any persons whilst the unit is operational. This calculation is based on the maximum conducted power and maximum antenna gain.
- IRU600, 5.8GHz, has been certified for use with a parabolic antenna with a maximum gain of 45.9dBi or a flat panel antenna with a maximum gain of 28dBi.
- The filters and software provided with this product allow for transmission only in the frequency range 5725 – 5850 MHz to ensure compliance with the Canadian band edges.
- According to the conducted power limit in RSS-210 Annex 8, the power for this device has been limited to 1W (30dBm) at the antenna port.

#### **IRU 600v4**

- IRU 600, 5.8GHz, must be professionally installed and maintained.
- IRU 600, 5.8GHz, is compliant with Industry Canada RSS-247.
- To ensure compliance with the Industry Canada RF exposure requirements in RSS-102, a minimum distance of 18 meters must be maintained between the antenna and any persons whilst the unit is operational. This calculation is
  - based on the maximum conducted power and maximum antenna gain.
  - The filters and software provided with this product allow for transmission only in the frequency range 5725 – 5850MHz to ensure compliance with the Canadian band edges.
  - According to the conducted power limit in RSS-247 the power for this device has been limited to 1W (30dBm) at the antenna port.
- This device complies with ISED's license-exempt RSSs. Operation is subject to the following two conditions:
  - (1) This device may not cause interference; and
  - (2) This device must accept any interference, including interference that may cause undesired operation of the device.
- This radio transmitter (IC: 4469A-IRU600v4) has been approved by ISED to operate with the antenna types listed below with the maximum permissible gain indicated. Antenna types not included in this list, having a gain greater than the maximum gain indicated for that type, are strictly prohibited for use with this device. IRU 600v4, 5.8GHz, has been certified for use with a parabolic or flat panel antenna with a maximum gain of 43dBi. Please see [Antennas certified for use with IRU 600v4 at 5.8GHz on page 125](#) for a list of the antennas approved for use with this radio.
- Under ISED regulations, this radio transmitter may only operate using an antenna of a type and maximum (or lesser) gain approved for the transmitter by ISED. To reduce potential radio interference to other users, the antenna type and its gain should be so chosen that the equivalent isotropically radiated power (e.i.r.p.) is not more than that necessary for successful communication.

## ISDE (Canada)

### IRU 600v2/v3

- L'IRU600, 5.8 GHz, doit être mis en oeuvre et maintenu par des professionnels.
- L'IRU600, 5.8 GHz, est conforme à la spécification RSS-210 d'Industrie Canada.
- Pour assurer la conformité aux exigences d'exposition de la spécification RSS-102 d'Industrie Canada, une distance minimum de 18 mètres entre l'antenne et toute personne doit être assurée quand l'équipement est en fonctionnement. Ce calcul est basé sur la puissance émise maximum et le gain maximum de l'antenne.
- L'IRU600, 5.8 GHz, a été homologué avec utilisation d'une antenne parabolique de gain maximum 45.9 dBi ou d'une antenne plane de gain maximum 28 dBi.
- Les filtres et le logiciel fournis avec ce produit permettent la transmission dans la bande de fréquences 5725 – 5850 MHz seulement, pour assurer la conformité avec les limites de bande canadiennes.
- En conformité avec la limite de puissance émise de la spécification RSS-210 Annexe 8, la puissance de cet équipement a été limitée à 1 W (30dBm) à l'accès de l'antenne.

### IRU 600v4

- L'IRU 600, 5.8 GHz, doit être installé et maintenu par des professionnels.
- L'IRU 600, 5.8 GHz, est conforme à la spécification RSS-247 de l'Industrie du Canada.
- Pour assurer la conformité aux exigences d'exposition de la spécification RSS-102 de l'Industrie du Canada, une distance minimum de 18 mètres doit être assurée entre l'antenne et une personne, quand l'équipement est en fonctionnement. Ce calcul est basé sur la puissance émise maximum et le gain maximum de l'antenne.
- Les filtres et le logiciel fournis avec ce produit permettent la transmission dans la bande de fréquences 5 725 – 5 850 MHz seulement, pour assurer la conformité avec les limites de bande canadiennes.
- En conformité avec la limite de puissance émise de la spécification RSS-247 la puissance de cet équipement a été limitée à 1 W (30 dBm) à l'accès de l'antenne.
- Cet appareil est conforme aux notre RSS exemptes de licence de l'ISED. Son utilisation est soumise aux deux conditions suivantes:
  - (1) Cet appareil ne doit pas causer d'interférence; et
  - (2) Cet appareil doit accepter tout type d'interférence, y compris les interférences susceptibles de provoquer un fonctionnement indésirable de l'appareil.
- Cet émetteur radio (IC: 4469A-IRU600v4) a été approuvé par l'ISED pour fonctionner avec les types d'antenne listés ci-dessous avec le gain maximum admissible indiqué. Les types d'antennes non inclus dans cette liste, ayant un gain supérieur au gain maximal indiqué pour ce type, sont strictement interdits pour une utilisation avec cet appareil. L'IRU 600v4, 5,8 GHz, a été certifié pour une utilisation

avec une antenne parabolique ou à une antenne plate d'un gain maximum de 43 dBi. Se référer à la [Antennas certified for use with IRU 600v4 at 5.8GHz on page 125](#) pour une liste d'antennes approuvée pour l'utilisation avec cette radio.

- En vertu des règlements de l'ISED, cet émetteur radio ne peut fonctionner qu'avec une antenne de type et un gain maximum (ou inférieur) approuvé pour l'émetteur par l'ISED. Pour réduire les interférences radio potentielles avec d'autres utilisateurs, le type d'antenne et son gain doivent être choisis de manière à ce que la puissance isotrope rayonnée équivalente (eirp) ne soit pas supérieure à celle nécessaire à établissement de la liaison.

## International Use of 5.8 GHz

IRU600, 5.8 GHz, does not employ DFS, and as such the equipment cannot be deployed within Europe or any country where DFS is a regulatory requirement for protection of radars.

## Networking Devices in Electric Power Substations

For IEEE 1613 compliant products, category 7 Ethernet cables must be used in order to ensure compliance.

## NEBS Compliance

The Eclipse Node comprising the INU/ INUe and IRU 600 complies with the relevant NEBS requirements under GR-1089-CORE and GR-63-CORE.

Such compliance requires installation of the Fan Air Filter option in the INUs, and adherence to the health and safety and equipment installation practices described herein.

## WEEE Directive

In accordance with the WEEE Directive (2012/19/EU), Eclipse is marked with the following symbol:

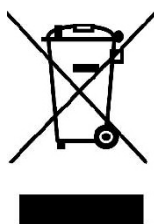

This symbol indicates that this equipment should be collected separately for the purposes of recovery and/or recycling.

For information about collection and recycling of Aviat Networks equipment please contact your local Aviat Networks sales office. If you purchased your product via a distributor please contact the distributor for information regarding collection and recovery/recycling.

More information on the WEEE Directive is available at our website:



<http://www.aviatnetworks.com/products/compliance/weee/>.





(WEEE is the acronym for Waste Electrical and Electronic Equipment)









## RoHS Directive

Eclipse meets the requirements of ROHS directive 2011/65/EU.

## Declaration of Conformity, Radio Equipment Directive (RED), 2014/53/EU

 Bulgaria	С настоящото Aviat Networks декларира, че този тип радиосъоръжение Eclipse A600/Eclipse A600sp/Eclipse LL/STR 600 е в съответствие с Директива 2014/53/ЕС. Цялостният текст на ЕС декларацията за съответствие може да се намери на следния интернет адрес: <a href="http://www.aviatnetworks.com">www.aviatnetworks.com</a>
 Czech Republic	Tímto Aviat Networks prohlašuje, že typ rádiového zařízení Eclipse A600/Eclipse A600sp/Eclipse LL/STR 600 je v souladu se směrnicí 2014/53/EU. Úplné znění EU prohlášení o shodě je k dispozici na této internetové adrese: <a href="http://www.aviatnetworks.com">www.aviatnetworks.com</a>
 Denmark	Hermed erklærer Aviat Networks, at radioudstyrstypen Eclipse A600/Eclipse A600sp/Eclipse LL/STR 600 er i overensstemmelse med direktiv 2014/53/EU. EU-overensstemmelseserklæringens fulde tekst kan findes på følgende internetadresse: <a href="http://www.aviatnetworks.com">www.aviatnetworks.com</a>
 Germany Austria Switzerland Belgium Luxembourg Netherlands Liechtenstein	Hiermit erkläre Aviat Networks, dass der Funkanlagentyp Eclipse A600/Eclipse A600sp/Eclipse LL/STR 600 der Richtlinie 2014/53/EU entspricht. Der vollständige Text der EU-Konformitätserklärung ist unter der folgenden Internetadresse verfügbar: <a href="http://www.aviatnetworks.com">www.aviatnetworks.com</a>
 Estonia	Käesolevaga deklareerib Aviat Networks, et käesolev raadioseadme tüüp Eclipse A600/Eclipse A600sp/Eclipse LL/STR 600 vastab direktiivi 2014/53/EL nõuetele. ELi vastavusdeklaratsiooni täielik tekst on kättesaadav järgmisel internetiaadressil: <a href="http://www.aviatnetworks.com">www.aviatnetworks.com</a>
 United Kingdom Ireland Malta	Hereby, Aviat Networks declares that the radio equipment type Eclipse A600/Eclipse A600sp/Eclipse LL/STR 600 is in compliance with Directive 2014/53/EU. The full text of the EU declaration of conformity is available at the following internet address: <a href="http://www.aviatnetworks.com">www.aviatnetworks.com</a>
 Spain	Por la presente, Aviat Networks declara que el tipo de equipo radioeléctrico Eclipse A600/Eclipse A600sp/Eclipse LL/STR 600 es conforme con la Directiva 2014/53/UE. El texto completo de la declaración UE de conformidad está disponible en la dirección Internet siguiente: <a href="http://www.aviatnetworks.com">www.aviatnetworks.com</a>

 Greece  Cyprus	<p>Με την παρούσα ο/η Aviat Networks, δηλώνει ότι ο ραδιοεξοπλισμός Eclipse A600/Eclipse A600sp/Eclipse LL/STR 600 πληροί την οδηγία 2014/53/EE. Το πλήρες κείμενο της δήλωσης συμμόρφωσης ΕΕ διατίθεται στην ακόλουθη ιστοσελίδα στο διαδίκτυο:</p> <p><a href="http://www.aviatnetworks.com">www.aviatnetworks.com</a></p>
 France  Luxembourg  Switzerland  Belgium	<p>Le soussigné, Aviat Networks, déclare que l'équipement radioélectrique du type Eclipse A600/Eclipse A600sp/Eclipse LL/STR 600 est conforme à la directive 2014/53/UE. Le texte complet de la déclaration UE de conformité est disponible à l'adresse internet suivante: <a href="http://www.aviatnetworks.com">www.aviatnetworks.com</a></p>
 Italy  Switzerland	<p>Il fabbricante, Aviat Networks, dichiara che il tipo di apparecchiatura radio Eclipse A600/Eclipse A600sp/Eclipse LL/STR 600 è conforme alla direttiva 2014/53/UE. Il testo completo della dichiarazione di conformità UE è disponibile al seguente indirizzo Internet: <a href="http://www.aviatnetworks.com">www.aviatnetworks.com</a></p>
 Latvia	<p>Ar šo Aviat Networks deklarē, ka radioiekārta Eclipse A600/Eclipse A600sp/Eclipse LL/STR 600 atbilst Direktīvai 2014/53/ES. Pilns ES atbilstības deklarācijas teksts ir pieejams šādā interneta vietnē: <a href="http://www.aviatnetworks.com">www.aviatnetworks.com</a></p>
 Lithuania	<p>Aš, Aviat Networks, patvirtinu, kad radijo įrenginių tipas Eclipse A600/Eclipse A600sp/Eclipse LL/STR 600 atitinka Direktyvą 2014/53/ES. Visas ES atitikties deklaracijos tekstas prieinamas šiuo interneto adresu: <a href="http://www.aviatnetworks.com">www.aviatnetworks.com</a></p>
 Netherlands  Belgium	<p>Hierbij verklaar ik, Aviat Networks, dat het type radioapparatuur Eclipse A600/Eclipse A600sp/Eclipse LL/STR 600 conform is met Richtlijn 2014/53/EU. De volledige tekst van de EU-conformiteitsverklaring kan worden geraadpleegd op het volgende internetadres: <a href="http://www.aviatnetworks.com">www.aviatnetworks.com</a></p>
 Croatia	<p>Aviat Networks ovime izjavljuje da je radijska oprema tipa Eclipse A600/Eclipse A600sp/Eclipse LL/STR 600 u skladu s Direktivom 2014/53/EU. Cjeloviti tekst EU izjave o sukladnosti dostupan je na sljedećoj internetskoj adresi: <a href="http://www.aviatnetworks.com">www.aviatnetworks.com</a></p>
 Malta	<p>B'dan, Aviat Networks, niddikjara li dan it-tip ta' tagħmir tar-radju Eclipse A600/Eclipse A600sp/Eclipse LL/STR 600 huwa konformi mad-Direttiva 2014/53/UE. It-test kollu tad-dikjarazzjoni ta' konformità tal-UE huwa disponibbli f'dan l-indirizz tal-Internet li ġej: <a href="http://www.aviatnetworks.com">www.aviatnetworks.com</a></p>
 Hungary	<p>Aviat Networks igazolja, hogy a Eclipse A600/Eclipse A600sp/Eclipse LL/STR 600 típusú rádióberendezés megfelel a 2014/53/EU irányelvnek. Az EU-megfelelőségi nyilatkozat teljes szövege elérhető a következő internetes címen: <a href="http://www.aviatnetworks.com">www.aviatnetworks.com</a></p>
 Poland	<p>Aviat Networks niniejszym oświadcza, że typ urządzenia radiowego Eclipse A600/Eclipse A600sp/Eclipse LL/STR 600 jest zgodny z dyrektywą 2014/53/UE. Pełny tekst deklaracji zgodności UE jest dostępny pod następującym adresem internetowym: <a href="http://www.aviatnetworks.com">www.aviatnetworks.com</a></p>

 Portugal	Aviat Networks niniejszym oświadcza, że typ urządzenia radiowego Eclipse A600/Eclipse A600sp/Eclipse LL/STR 600 jest zgodny z dyrektywą 2014/53/UE. Pełny tekst deklaracji zgodności UE jest dostępny pod następującym adresem internetowym: <a href="http://www.aviatnetworks.com">www.aviatnetworks.com</a>
 Slovenia	Aviat Networks potrjuje, da je tip radijske opreme Eclipse A600/Eclipse A600sp/Eclipse LL/STR 600 skladen z Direktivo 2014/53/EU. Celotno besedilo izjave EU o skladnosti je na voljo na naslednjem spletnem naslovu: <a href="http://www.aviatnetworks.com">www.aviatnetworks.com</a>
 Slovakia	Aviat Networks týmto vyhlasuje, že rádiové zariadenie typu Eclipse A600/Eclipse A600sp/Eclipse LL/STR 600 je v súlade so smernicou 2014/53/EÚ. Úplné EÚ vyhlásenie o zhode je k dispozícii na tejto internetovej adrese: <a href="http://www.aviatnetworks.com">www.aviatnetworks.com</a>
 Finland	Aviat Networks vakuuttaa, että radiolaitetyyppi Eclipse A600/Eclipse A600sp/Eclipse LL/STR 600 on direktiivin 2014/53/EU mukainen. EU-vaatimustenmukaisuusvakuutuksen täysimittainen teksti on saatavilla seuraavassa internetosoitteessa: <a href="http://www.aviatnetworks.com">www.aviatnetworks.com</a>
 Sweden	Härmed försäkrar Aviat Networks att denna typ av radioutrustning Eclipse A600/Eclipse A600sp/Eclipse LL/STR 600 överensstämmer med direktiv 2014/53/EU. Den fullständiga texten till EU-försäkran om överensstämmelse finns på följande webbadress: <a href="http://www.aviatnetworks.com">www.aviatnetworks.com</a>
 Iceland	Hér með lýsir Aviat Networks yfir því að Eclipse A600/Eclipse A600sp/Eclipse LL/STR 600 er í samræmi við grunnkröfur og aðrar kröfur, sem gerðar eru í tilskipun 2014/53/EU.
 Norway	Aviat Networks erklærer herved at utstyret Eclipse A600/Eclipse A600sp/Eclipse LL/STR 600 er i samsvar med de grunnleggende krav og øvrige relevante krav i direktiv 2014/53/EU.
 România	Prin prezenta, Aviat Networks declară că tipul de echipamente radio Eclipse A600/Eclipse A600sp/Eclipse LL/STR 600 este în conformitate cu Directiva 2014/53/UE. Textul integral al declarației UE de conformitate este disponibil la următoarea adresă internet: <a href="http://www.aviatnetworks.com">www.aviatnetworks.com</a>

Full declarations of conformity are available at:

<http://aviatnetworks.com/doc/EclipseA600.pdf>

<http://aviatnetworks.com/doc/EclipseA600sp.pdf>

<http://aviatnetworks.com/doc/EclipseLL.pdf>

<http://aviatnetworks.com/doc/STR60011.pdf>

<http://aviatnetworks.com/doc/STR600L6U678.pdf>

## Country Availability Matrix

Aviat's radios are classified under the Radio Equipment Directive (2014/53/EU) as Class 2 products. For details of where the equipment is intended to be used, see the country matrix below. Aviat Networks intends to market this equipment where a cross (X) is shown.

Band (GHz)	L6	U6	07	08	10	11	13	15	18	23	26	28	32	38	42
Austria	X	X	X	X	X	X	X	X	X	X	X	X	X	X	X
Belgium	X	X	X	X		X	X	X	X	X	X	X	X	X	
Bulgaria	X	X	X	X	X	X	X		X	X	X	X	X	X	
Cyprus	X	X	X	X	X	X	X	X	X	X	X	X	X	X	
Czech Republic	X	X	X			X	X	X	X	X	X		X	X	
Denmark	X	X	X			X	X	X	X	X	X		X	X	X
Estonia	X	X	X	X	X	X	X	X	X	X	X	X	X	X	X
Finland	X	X	X	X	X		X	X	X	X	X	X	X	X	X
France	X	X	X	X	X	X	X	X	X	X	X	X	X	X	
Germany	X	X	X	X	X	X	X	X	X	X	X	X	X	X	X
Greece	X		X				X	X	X	X	X			X	
Hungary	X	X	X	X		X	X	X	X	X	X			X	
Iceland	X	X	X	X	X	X	X	X	X	X	X	X		X	
Ireland	X	X	X	X		X	X	X	X	X	X			X	
Italy	X	X	X	X	X	X	X	X	X	X	X		X	X	
Latvia	X	X	X	X			X	X	X	X	X	X		X	
Lithuania	X	X	X	X	X	X	X	X	X	X	X	X	X	X	
Luxembourg	X	X	X	X	X		X	X	X	X	X	X	X	X	
Malta	X	X	X	X	X	X	X	X	X	X			X	X	X
Netherlands	X	X	X				X	X	X	X	X	X	X	X	
Norway	X	X	X	X		X	X	X	X	X	X	X		X	X
Poland	X	X	X	X		X	X	X	X	X	X	X	X	X	X
Portugal	X	X	X	X		X	X	X	X	X	X			X	X
Romania	X	X	X	X	X	X	X	X	X	X	X	X	X	X	X
Slovak Republic	X	X	X		X	X	X	X	X	X	X	X	X	X	
Slovenia	X	X	X	X		X	X	X	X	X	X	X	X	X	X
Spain	X	X		X	X	X	X	X	X	X	X	X		X	
Sweden	X	X	X	X			X	X	X	X	X		X	X	
Switzerland	X	X	X		X	X	X	X	X	X	X	X	X	X	X
United Kingdom	X	X	X			X	X	X	X	X	X	X	X	X	X

**IT SHOULD BE NOTED THAT A LICENSE TO OPERATE THIS EQUIPMENT WILL BE REQUIRED AND THE RELEVANT REGULATOR MUST BE CONTACTED PRIOR TO INSTALLATION AND COMMISSIONING.**

# Contents

---

Copyright & Terms of Use .....	iii
Aviat Networks Technical Support .....	v
Product Compliance Notes .....	vii
Regulatory Information for 5.8 GHz Band .....	vii
Networking Devices in Electric Power Substations .....	xi
NEBS Compliance .....	xi
WEEE Directive .....	xi
RoHS Directive .....	xii
Declaration of Conformity, Radio Equipment Directive (RED), 2014/53/EU .....	xii
Contents .....	xvi
<b>CHAPTER 1. ABOUT ECLIPSE .....</b>	<b>19</b>
What Is Eclipse? .....	20
Installation and User Prerequisites .....	21
About the Eclipse Documentation .....	22
Conventions and Terminology .....	23
<b>CHAPTER 2. HEALTH AND SAFETY .....</b>	<b>25</b>
General Health and Safety .....	26
Operator Health and Safety .....	27
General Hazards .....	28
RF Exposure Guidelines .....	32
ODU 600 .....	32
STR 600 .....	33
ODU 300 Series .....	33
Routine Inspection and Maintenance .....	37
Routine Inspections .....	37
Trend Analysis .....	37
Fault Analysis .....	38
Training .....	38
Spares .....	38
<b>CHAPTER 3. SYSTEM OVERVIEW .....</b>	<b>39</b>
Eclipse Node and Packet Node .....	40
Node Indoor Units .....	41
INU .....	41
INUe .....	42
Plug-in Cards .....	42
Plug-in Cards Overview .....	43
Protection Options .....	53



Link/Path Protection .....	53
Interface Protection .....	53
Network/Data Protection .....	54
Platform Protection .....	55
Eclipse Packet Node and Data Packet Plane .....	55
Data Packet Plane .....	55
Advanced Adaptive Coding and Modulation (ACM) .....	56
Platforms .....	57
Platform Layout .....	57
Slot Assignments .....	58
Eclipse Terminals .....	60
300 Series Indoor Units .....	60
IDU 300 Series Overview .....	61
Eclipse Radio Frequency Units .....	67
IRU 600 .....	67
IRU 600 Variants .....	68
5.8 GHz Unlicensed Band .....	74
Eclipse Licensing .....	76
Eclipse Configuration and Management .....	80
Eclipse Antennas .....	81
Eclipse Power Supply .....	82
<b>CHAPTER 4. INTRODUCTION TO ECLIPSE INSTALLATION .....</b>	<b>83</b>
Installation Overview .....	84
Before Going On Site .....	85
Installation Tools and Materials .....	85
Unpacking the Eclipse Equipment .....	86
<b>CHAPTER 5. IRU 600 INSTALLATION .....</b>	<b>87</b>
IRU 600 Compatibility .....	88
IRU 600 Installation Procedure .....	90
Chassis Installation .....	90
Chassis Grounding .....	93
NEBS Compliant Grounding .....	93
Safety Requirements for Equipment Grounding .....	94
Waveguide Installation .....	94
Waveguide Connection to ACU .....	94
Power Supply Connection .....	95
Insertion Loss Labels .....	97
Expansion Port Use .....	97
FAN Module .....	97
Chassis Adapter Kit for IRU 600v3 and IRU 600v4 RFUs .....	98
Next Steps .....	100
<b>CHAPTER 6. INSTALLING THE INU AND INUE .....</b>	<b>101</b>
INU/INUE Description .....	102
INU Front Panel Layout .....	102

INU Power Supply .....	103
Power Consumption and INU Load Maximums .....	103
PCC +24 Vdc Operation .....	111
Power Cables .....	112
Fuses .....	113
FAN Air Filter Option .....	113
Fan Air Filter Installation .....	113
Power Line Filter Option .....	114
INU/INUe Installation Requirements .....	115
Installation .....	118
Plug-in Installation Requirements .....	121

**APPENDIX A. ANTENNAS CERTIFIED FOR USE WITH IRU**  
**600V4 AT 5.8GHZ .....** **125**

# Chapter 1. About Eclipse

---

Welcome to the Eclipse User Manual.

This introduction describes:

- [What Is Eclipse? on page 20](#)
- [Installation and User Prerequisites on page 21](#)
- [About the Eclipse Documentation on page 22](#)
- [About the Eclipse Documentation on page 22](#)

# What Is Eclipse?

---

The Eclipse Microwave Radio System comprises the indoor mounted Node or Terminal, and associated indoor or outdoor radio frequency units.

- Eclipse Node supports multiple point-to-point radios for Ethernet, PDH, SDH, on a single rack-mounted platform, to form a complete network node for star or ring configurations on frequency bands 5 to 42 GHz. Plug-in modules provide the customization for link and user interface requirements.
- Eclipse Terminal is optimized for single-link installations or where back-to-back network connection of terminals is preferred. Terminals may also be used on spur links from an Eclipse Node. Different versions are available for Ethernet, PDH, SDH, on frequency bands 5 to 42 GHz.

# Installation and User Prerequisites

---

To install, commission, and maintain Eclipse, we recommend you have the following knowledge and skills:

- A basic understanding of the principles of microwave transmission.
- Installation and maintenance experience on Ethernet, PDH and SDH digital microwave radio systems.
- Familiarity with Ethernet and/or SDH multiplexing where these traffic options are to be employed on Eclipse.
- Familiarity with the operation of a PC using the Windows operating system.
- A thorough understanding of Eclipse systems, configuration, and diagnostics from attendance of an Aviat Networks training course on Eclipse.



**WARNING:** Follow health and safety procedures at all times! See [Health and Safety on page 25](#) for complete details.

# About the Eclipse Documentation

---

This documentation provides information on installing, configuring, commissioning, and troubleshooting an Eclipse Microwave Radio system. Technical descriptions are at a module and system level.

## Intended Audience

This information is for use by trained technicians or engineers. It does not provide information or instruction on basic technical procedures. Aviat Networks recommends you read the relevant sections of this manual thoroughly before beginning any installation or operational procedures.

## Organization

This manual is divided into five volume-level sections:

- Health and Safety Requirements
- System Overview
- Installation
- Configuration and Diagnostics
- Commissioning and Troubleshooting
- Appendices

## Additional Resources

The resources identified below contain additional information.

- Eclipse Platform Product Description. Operational and application data for Eclipse Packet Node.
- IDU GE3 16x Product Description. Operational and application data for Eclipse IDU GE3 16x.
- Various White Papers.
- Aviat Networks Microwave Radio System Best Practices Guide. (PN 260-668029-001). Use to assist in installing, commissioning, and troubleshooting Eclipse and other microwave radio products.

Contact Aviat Networks or your supplier for availability.

# Conventions and Terminology

---

This document uses the following conventions and terminology.

## Graphic Cues

The following items have graphic cues to identify important supporting information.



**NOTE:** A **note** item identifies additional information about a procedure or function.



**CAUTION:** A **caution** item identifies important information pertaining to actions that may cause damage to equipment, loss of data, or corruption of files.



**WARNING:** A **warning** item identifies a serious physical danger or major possible problem.

## Font Changes

**Bold font** is used for the names of on-screen elements such as; fields, buttons, and drop-down selection lists, keywords, commands and for keys on the keyboard.

Courier font in **blue text** is used to indicate commands that the user needs to type in.

```
WTM4100# show radio-carrier status Carrier1/1
```

Any responses or report output from a command is shown as **brown text** and indented.

```
    radio-carrier status Carrier1/1  
    oper-status up
```

*Italic font* is used to emphasize words and phrases, to introduce new terms, and for the titles of printed publications.

## Common Terminology

**Click or Select:** Point the mouse pointer at the item you want to select, then quickly press and release the left mouse button.

**Right-Click:** Point the mouse pointer at the item you want to select, then quickly press and release the right mouse button.





## Chapter 2. Health and Safety

---

This section includes the following health and safety information:

- [General Health and Safety on page 26](#)
- [Operator Health and Safety on page 27](#)
- [General Hazards on page 28](#)
- [RF Exposure Guidelines on page 32](#)

All personnel must comply with the relevant health and safety practices when working on or around Eclipse radio equipment.

The Eclipse system has been designed to meet relevant US and European health and safety standards as outlined in IEC Publication 60950-1.

Eclipse is a Class A product. It is intended to be used exclusively in telecommunications centers.

Local safety regulations must be used if mandatory. Safety instructions in this Volume should be used in addition to the local safety regulations. In the case of conflict between safety instructions stated herein and those indicated in local regulations, mandatory local norms will prevail. Should not local regulations be mandatory, then safety norms herein will prevail.



**WARNING:** Hot Surfaces - the external surfaces of an ODU 600v2 can be hot to touch, especially at high ambient temperatures. A hot surfaces warning icon is displayed on

the product:



# General Health and Safety

---

This table describes general health and safety information about the Eclipse radio.

Topic	Information
<b>Flammability</b>	Eclipse is designed and constructed to minimize the risk of smoke and fumes during a fire.
<b>Hazardous Materials</b>	No hazardous materials are used in the construction of the equipment.
<b>Hazardous Voltage</b>	Eclipse meets global product safety requirements for safety extra-low voltage (SELV) rated equipment where the input voltage <i>must</i> be 48 V nominal, 60 V maximum.
<b>Safety Signs</b>	External warning signs or other indicators on the equipment are not required.
<b>Surface Temperatures</b>	The external equipment surfaces do become warm during operation due to heat dissipation. However, the temperatures reached are not considered hazardous.

# Operator Health and Safety

The following table describes the precautions that relate to installing or working on an Eclipse radio.

Topic	Information
<b>Equipment Protrusions</b>	Eclipse has been designed to be free of unnecessary protrusions or sharp surfaces that may catch or otherwise cause injury during handling. However, always take care when working on or around the equipment.
<b>Laser and Fiber Optic Cable Hazards</b>	<p>Eclipse fiber optic transmitters are IEC60825-1 / 21CFR1040-1 Class I compliant and present no danger to personnel in normal use. However:</p> <p>Do not look into active unterminated optical ports or fibers. If visual inspection is required ensure the equipment is turned off or, if a fiber cable, disconnect the far end.</p> <p>Follow the manufacturer's instructions when using an optical test set. Incorrect calibration or control settings could result in hazardous levels of radiation.</p> <p>Protect/cover unconnected optical fiber connectors with dust caps.</p> <p>Place all optical fiber cuttings in a suitable container for safe disposal. Bare fibers and fiber scraps can easily penetrate the skin and eyes.</p>
<b>Lifting Equipment</b>	Be careful when hoisting or lifting an antenna or ODU during installation or maintenance. A large antenna with its mounting hardware can weigh in excess of 100 kg (220 lb) and require specialized lifting equipment and an operator trained and certified in its use.
<b>Protection from RF Exposure: Eclipse</b>	Eclipse radio transceivers do not generate RF fields intense enough to cause RF burns. However, when installing, servicing or inspecting an antenna always comply with the Protection from RF Exposure guidelines under <a href="#">General Hazards on page 28</a> .
<b>Safety Warnings</b>	When a practice or procedure poses implied or potential harm to the user or to the Eclipse equipment, a warning is included in this manual.

## General Hazards

The following table describes the general hazards that must be addressed when planning and installing an Eclipse system.

For more information on health and safety when using Aviat Networks products, refer to the *Best Practices Guide*.

Topic	Information
<b>Airflow Requirements</b>	<p>Rack installations must be made so the airflow required for safe and correct operation of Eclipse is not compromised. For the fan-cooled Eclipse INUs and fan-cooled Eclipse IDUs, unobstructed air passage must be maintained to each side of the chassis, which requires a minimum of 50 mm (2 inches) of side spacing to any rack panels, cable bundles or similar. Unused slots on the INU/INUe must be fitted with a blanking panel.</p> <p>Where a Fan Air Filter is installed in an INU it must not be allowed to become clogged with dust. Replace when necessary. Inspection must be at not more than 12 monthly intervals when installed in telecommunications equipment room controlled-air environments. Otherwise, inspection is required at more frequent intervals.</p>
<b>EMC</b>	<p>Eclipse has been tested for and meets EMC Directive 89/336/EEC. The equipment was tested using screened cable; if any other type of cable is used, it may violate compliance.</p> <p>Eclipse is a Class A product. In a domestic environment this product may cause radio interference in which case the user may be required to take adequate measures. This equipment is intended to be used exclusively in telecommunications centers.</p>
<b>ESD</b>	<p>ESD (electrostatic discharge) can damage electronic components. Even if components remain functional, ESD can cause latent damage that results in premature failure. Always wear proper ESD grounding straps when changing or handling the plug-in cards and avoid hand contact with the PCB back-plane and top-plane. Connect your ESD grounding strap to the combined ESD and ground connector on the INU rack ear. Spare plug-in cards or cards to be returned for service must be enclosed in an anti-static bag. When removing a card from the anti-static bag for installation in an INU, or placing a card in a bag, do so at the INU and only when connected to the INU via your ESD grounding strap.</p>
<b>Circuit Overloading</b>	<p>When connecting an Eclipse terminal, determine the effect this will have on the power supply circuit protection devices, and supply wiring. Check Eclipse power consumption specifications and the supply capability of the power supply system. This check of capacity must extend to the dc power supply and not just to an intermediate connection point.</p>

Topic	Information
<b>Eclipse Indoor Unit and DC Supply Grounding</b>	The ground for Eclipse indoor unit(s) must be connected directly to the dc supply system ground conductor, or to a bonding jumper from a grounding terminal bar, or bus to which the dc supply system grounding is connected.
<b>Intrabuilding interfaces and cabling for NEBS compliance</b>	<p>Intrabuilding connections to/from Eclipse ports must only be connected via intrabuilding or unexposed wiring or cabling.</p> <p>Intrabuilding ports MUST NOT be metalically connected to interfaces that connect to the OSP or its wiring. These interfaces are designed for use as intrabuilding interfaces only (Type 2 or Type 4 ports as described in GR-1089-CORE, Issue 4) and require isolation from the exposed OSP cabling. The addition of Primary Protectors is not sufficient protection in order to connect these interfaces metalically to OSP wiring.</p> <p>Shielded and grounded cables must be used for intrabuilding cabling to/from Eclipse ports. Cables must be grounded at both ends.</p>
<b>Protection from RF Exposure</b>	<p>When installing, servicing or inspecting an antenna always comply with the following:</p> <ul style="list-style-type: none"> <li>Locate the antenna such that it does not infringe the RF exposure guidelines for general public. Refer to General Public Compliance Boundary in <a href="#">RF Exposure Guidelines on page 32</a>.</li> <li>Stay aware of the potential risk of RF exposure and take appropriate precautions. Refer to Occupational Compliance Boundary in <a href="#">RF Exposure Guidelines on page 32</a>.</li> <li>Do not stand in front of or look into an antenna without first ensuring the associated transmitter or transmitters are switched off.</li> <li>Do not look into waveguide or into the waveguide port of an RFU without first ensuring the associated transmitter or transmitters are switched off.</li> <li>At a multi-antenna site ask the site owner or operator for details of other radio services active at the site and for their requirements/recommendations for protection against potentially harmful exposure to RF radiation.</li> <li>When it is not possible to switch transmitters off at a multi-antenna site and there is potential for exposure to harmful levels of RF radiation, wear a protective suit.</li> </ul>
<b>Fiber Optic Cables</b>	<p>Handle optical fibers with care. Keep them in a safe and secure location during installation.</p> <p>Do not attempt to bend them beyond their minimum bend radius.</p> <p>Protect/cover unconnected optical fiber connectors with dust caps.</p>
<b>Ground Connections</b>	<p>Reliable grounding of the Eclipse system must be maintained. Refer to instructions in the manual for grounding of waveguide, ODU cable, lightning surge suppressor, ODU, and indoor unit.</p> <p>There must be no switching or disconnecting devices fitted in ground conductors.</p>
<b>Lightning Surge Suppressor</b>	Eclipse ODU cables must be fitted with the specified surge suppressor at the ODU unless the ODU has a built-in suppressor.

Topic	Information
<b>Mains Power Supply Routing</b>	Eclipse dc power, IF, tributary, auxiliary and NMS cables are not to be routed with any AC mains power lines. They are also to be kept away from any power lines which cross them.
<b>Maximum Ambient Temperature</b>	The maximum ambient temperature (T <sub>mra</sub> ) for Eclipse indoor units and outdoor units is +55° C (131° F). Special conditions apply to the INUs - for more information see Power Consumption within <a href="#">INU Power Supply on page 103</a> . To ensure correct operation and to maximize long term component reliability, ambient temperatures must not be exceeded. Operational specification compliance is not guaranteed for higher ambients.
<b>Mechanical Loading</b>	When installing an indoor unit in a rack, ensure the rack is securely anchored. Ensure that the additional loading of an Eclipse indoor unit or units will not cause any reduction in the mechanical stability of the rack.
<b>Power Supply Connection</b>	<p>The Eclipse INU/INUe and IDUs have the +ve pin on their dc power supply connector connected to chassis ground. It must be used with a -48 Vdc power supply which has a +ve ground; the power supply ground conductor is the +ve supply to the radio. For NEBS compliance the battery return connection is to be treated as a common DC return (DC-C), as defined in GR-1089-CORE.</p> <p>For IRU 600 variants that require a separate wide-mouth +/-21 to +/-60 Vdc power supply connection, both pins on its power supply connector are isolated from chassis ground. For NEBS compliance the battery return connection is to be treated as an isolated DC return (DC-I), as defined in GR-1089-CORE.</p> <p>The d.c. supply source must be located within the same premises as the equipment.</p>
<b>Connection to D.C. Supply Ground</b>	<hr/> <p> <b>CAUTION:</b> The Eclipse INU/INUe and IDUs have a connection between the earthed conductor of the d.c. supply circuit and the earthing conductor.</p> <hr/> <p>This equipment must be connected directly to the d.c. supply system grounding electrode conductor or to a bonding jumper from a grounding terminal bar or bus to which the d.c. supply system grounding electrode is connected.</p> <p>Switching or disconnecting devices must not be in the grounded circuit conductor between the d.c. source and the point of connection of the grounding electrode conductor.</p> <p>This equipment must be located in the same immediate area (such as, adjacent cabinets) as any other equipment that has a connection between the grounded conductor of the same d.c. supply circuit and the grounding conductor, and also the point of grounding of the d.c. system. The d.c. system shall not be grounded elsewhere.</p>
<b>Power Supply Disconnect</b>	An appropriate disconnect device for the -48 Vdc or +24 Vdc power supply unit must be provided as part of the building installation.

Topic	Information
<b>Rack Mount Temperature Considerations</b>	If the Eclipse indoor unit is installed in a closed or multi-unit rack assembly, the operating ambient temperature of the rack environment may be greater than room ambient. The maximum ambient temperature applies to the immediate operating environment of the Eclipse indoor unit, which, if installed in a rack, is the ambient within the rack.
<b>Restricted Access</b>	The Eclipse system must be installed in restricted access sites. The indoor unit and associated power supply must be installed in restricted areas, such as dedicated equipment rooms, closets, cabinets, or the like. Access to the tower and antenna location must be restricted
	 <b>NOTE:</b> For USA: In restricted access areas install the Eclipse system in accordance with articles 110-26 and 110-27 of the 2002 National Electrical Code ANSI/NFPA 70, or to any subsequent update to this code for the relevant articles.

# RF Exposure Guidelines

Data is provided for Eclipse ODU 600, STR 600 and ODU 300.

## ODU 600

The following MPE (maximum permissible exposure) calculations have been produced in accordance with the guidelines of EN 50383/EN 50385 and Section 1.1310 of the FCC's rules. These calculations represent the maximum conducted output power and the maximum antenna gain, by frequency range. These calculations are based on the exposure requirements for the general public. If the antennas used with this device exceed the gain values stated below, the installer must take additional precautions and re-calculate the minimum compliance boundary.

**Table 1.** MPE Guidelines for ODU 600

Frequency Range (GHz)	Minimum Compliance Distance (m)	TX conducted power (dBm)	Antenna Gain (dBi)
4.4 – 5.0	15.86	+30.0	45.0
5.925 - 7.11	9.78	+31	39.8
7.125 – 7.9	12.75	+32	41.1
7.725 - 8.5	11.36	+31	41.1
10.7 – 11.7	10.48	+27	44.4
12.75 – 13.25	11.23	+26.5	45.5
14.4 – 15.35	12.61	+26.5	46.5
17.7 – 19.7	10.49	+23	48.4
21.2 - 23.632	13.2	+23.5	49.9
24.25 – 26.483	12.31	+25	47.8
27.5 – 29.5	7.09	+25	43.0
31.8 – 33.4	6.18	+23	43.8
37.0 – 39.46	7.78	+23	45.8
40.5 - 43.5	6.54	+21	46.3

### Operation of ODU 600 on 5.8 GHz Unlicensed Band, USA and Canada

To ensure compliance with FCC and Industry Canada RF exposure requirements, a minimum distance of 18 meters must be maintained between the ODU 600 antenna and any persons whilst the unit is operational. This calculation is based on the maximum conducted power and maximum antenna gain permitted by FCC and Industry Canada RF for this band.



## STR 600

The following MPE (maximum permissible exposure) calculations have been produced in accordance with the guidelines of EN 50383/EN 50385 and Section 1.1310 of the FCC's rules. These calculations represent the maximum conducted output power and the maximum antenna gain, by frequency range. These calculations are based on the exposure requirements for the general public. If the antennas used with this device exceed the gain values stated below, the installer must take additional precautions and re-calculate the minimum compliance boundary.

**Table 2.** MPE Guidelines for STR 600

Frequency Range (GHz)	Minimum Compliance Distance (m)	TX conducted power (dBm)	Antenna Gain (dBi)
4.4 – 5.0	17.80	+31.0	45.0
5.925 - 7.11	13.04	+33.5	39.8
7.125 – 7.9	15.15	+33.5	41.1
7.725 -8.5	13.50	+32.5	41.1
10.0 – 11.7	15.69	+30.5	44.4

## ODU 300 Series

The following MPE (maximum permissible exposure) calculations for the Eclipse ODU 300 series have been produced in accordance with the guidelines of EN 50383/EN 50385. These calculations represent examples only and do not include every possible combination of output power and antenna gain.

Occupational is defined as: "The occupationally exposed population consists of adults who are generally exposed under known conditions and are trained to be aware of potential risk and to take appropriate precautions".

**Table 3.** MPE Guidelines for ODU 300

### 5 GHz (4.4 - 5.0 GHz)

Transmit Power (dBm)	Antenna Gain (dBm)	Compliance Boundary General Public (m)	Compliance Boundary Occupational (m)
30.5	39.3	8.77	3.91
30.5	32.6	4.06	1.81
0.5	39.3	0.28	0.12
0.5	32.6	0.13	0.06

### L6/U6 GHz (5.925 - 7.11 GHz)

Transmit Power (dBm)	Antenna Gain (dBm)	Compliance Boundary General Public (m)	Compliance Boundary Occupational (m)
30.5	41.5	11.30	5.03
30.5	31.2	3.45	1.54
0.5	41.5	0.36	0.16
0.5	31.2	0.11	0.05

**7/8 GHz (7.125 - 8.5 GHz)**

Transmit Power (dBm)	Antenna Gain (dBm)	Compliance Boundary General Public (m)	Compliance Boundary Occupational (m)
30.5	42.9	13.28	5.91
30.5	30.24	3.15	1.40
5.0	42.9	0.71	0.31
5.0	30.4	0.17	0.07

**10 GHz (10.0 - 10.68 GHz)**

Transmit Power (dBm)	Antenna Gain (dBm)	Compliance Boundary General Public (m)	Compliance Boundary Occupational (m)
26.0	34.3	2.94	1.31
26.0	33.7	2.74	1.22
-4.0	34.3	0.09	0.04
-4.0	33.7	0.09	0.04

**11 GHz (10.7 - 11.7 GHz)**

Transmit Power (dBm)	Antenna Gain (dBm)	Compliance Boundary General Public (m)	Compliance Boundary Occupational (m)
25.0	46.2	10.31	4.59
25.0	27.7	1.23	0.55
2.5	46.2	0.77	0.34
2.5	27.7	0.09	0.04

**13 GHz (12.75- 13.25 GHz)**

Transmit Power (dBm)	Antenna Gain (dBm)	Compliance Boundary General Public (m)	Compliance Boundary Occupational (m)
28.0	47.3	16.53	7.36
28.0	29.6	2.15	0.96
0.0	47.3	0.66	0.29
0.00	47.3	0.66	0.29
0.00	29.6	0.09	0.04

**15 GHz (14.4- 15.35 GHz)**

Transmit Power (dBm)	Antenna Gain (dBm)	Compliance Boundary General Public (m)	Compliance Boundary Occupational (m)
----------------------	--------------------	--	--------------------------------------

27.0	46.4	13.28	5.91
27.0	30.8	2.20	0.98
-1.0	46.4	0.53	0.24
-1.0	30.8	0.09	0.04

**18 GHz (17.7-19.7 GHz)**

Transmit Power (dBm)	Antenna Gain (dBm)	Compliance Boundary General Public (m)	Compliance Boundary Occupational (m)
21.5	48.0	8.48	3.77
21.5	32.8	1.47	0.66
-3.0	48.0	0.50	0.22
-3.0	32.8	0.09	0.04

**23 GHz (21.2-23.632 GHz)**

Transmit Power (dBm)	Antenna Gain (dBm)	Compliance Boundary General Public (m)	Compliance Boundary Occupational (m)
21.5	49.2	9.73	4.33
21.5	34.4	1.77	0.79
-3.0	49.2	0.58	0.26
-3.0	34.4	0.11	0.05

**26 GHz (24.52- 26.483 GHz)**

Transmit Power (dBm)	Antenna Gain (dBm)	Compliance Boundary General Public (m)	Compliance Boundary Occupational (m)
15.5	46.0	3.37	1.50
15.5	35.9	1.05	0.47
-4.5	46.0	0.34	0.15
-4.5	35.9	0.11	0.05

**28 GHz (27.5- 29.5GHz)**

Transmit Power (dBm)	Antenna Gain (dBm)	Compliance Boundary General Public (m)	Compliance Boundary Occupational (m)
15.0	48.1	4.06	1.81
15.0	36.5	1.07	0.48
-5.0	48.1	0.41	0.18
-5.0	36.5	0.11	0.05

**32 GHz (31.8- 33.4 GHz)**

Transmit Power (dBm)	Antenna Gain (dBm)	Compliance Boundary General Public (m)	Compliance Boundary Occupational (m)
17.5	43.5	3.19	1.42
17.5	37.5	1.60	0.71

-5.0	43.5	0.24	0.11
-5.0	37.5	0.12	0.05

**38 GHz (37.0- 39.46 GHz)**

Transmit Power (dBm)	Antenna Gain (dBm)	Compliance Boundary General Public (m)	Compliance Boundary Occupational (m)
17.5	48.1	5.41	2.41
17.5	39.3	1.96	0.87
-5.0	48.1	0.41	0.18
-5.0	39.3	0.15	0.07

# Routine Inspection and Maintenance

---

This section overviews required and recommended inspection and maintenance practices to ensure health and safety of installed equipment is maintained to highest levels. For more information, refer to the Aviat Networks publication: *Best Practices*.

## Routine Inspections

All sites must be inspected annually, or more frequently if subject to abnormal operating conditions such as particularly exposed sites, or sites subject to salt-spray or heavy snow/ice loading over winter months.

The inspection should cover the physical installation including the antenna, antenna feeder or IDU/ODU cable, cable grounding, equipment grounding, tower and building grounds, weatherproofing, lightning surge suppressors, and general site integrity.

Where a Fan Air Filter is installed in an INU (for NEBS compliance) it must be inspected annually, or more frequently if the INU is installed in an environment that is not controlled for dust exclusion.

Selected ground wires should be resistance checked and then compared with previous checks to ensure there has been no significant change.

The operational performance of the radio and associated equipment should be checked against their as-built figures using the Portal or ProVision alarm and performance indicators.

## Trend Analysis

Use available current and historical Eclipse alarm and performance data to determine any trend that may lead to a failure - if allowed to continue.

Check for the following trends:

- Reducing receive signal levels
- Gradually increasing bit errors or an increasing errored seconds count
- Changes in transmit power
- Increased frequency of rain fade or other fade conditions
- Increasing occurrence of other weather related changes in performance
- Increasing occurrence of a particular hardware failure

Time spent in conducting such analysis is time well spent. Catching a problem before it brings down the network is good network management.

## Fault Analysis

All faults, once cleared, should be the subject of a fault report. The data presented in these reports should be analyzed from time to time to check for any common threads, which may point to a particular weakness in the design, installation, or maintenance of the network or to a specific component.

The time taken to restore service and the parts used should also be analyzed to see if improvements are possible in the maintenance procedures, maintenance training and spares holdings.

## Training

Properly trained and experienced planning and installation personnel are essential for establishing and maintaining high integrity in a new network. Similarly, properly trained network management and service personnel are essential for the continued good health of a network.

The training needs for personnel should be reviewed from time-to-time to ensure they maintain expertise in their area of work, and on the installed base.

## Spares

Spares holdings should be reviewed on a regular basis to ensure the correct quantity and type are held, and held at the most appropriate locations.

Analysis of spares usage will show any trend for excessive use of spares, which may point to a weakness in the deployment or manufacture of the item.

Spares holdings should also be checked from time to time and if necessary brought up to the current hardware and/or software revision level.

## Chapter 3. System Overview

---

Eclipse is available on two platform types, Node, and Terminal.

This section overviews their features and capabilities. Refer to:

- [Eclipse Node and Packet Node on page 40](#)
- [Eclipse Terminals on page 60](#)
- [Eclipse Radio Frequency Units on page 67](#)
- [Eclipse Licensing on page 76](#)
- [Eclipse Strong Security on page 1](#)
- [Eclipse Configuration and Management on page 80](#)
- [Eclipse Antennas on page 81](#)
- [Eclipse Power Supply on page 82](#)

# Eclipse Node and Packet Node

---

**Eclipse Node** supports multiple radio links from a common indoor unit with airlink throughput capacities to 366 Mbit/s Ethernet, 100xE1, 127xDS1, 4xDS3, STM1+1E1, or 2xSTM1/OC3.

**Eclipse Packet Node** adds a data packet plane (DPP) to support Gigabit Ethernet throughputs, plus the traffic and capacity options provided on Eclipse Node.

Both Eclipse Node and Packet Node use common rack-mounted indoor units, the INU and INUe, and either ODUs for split-mount operation, or an IRU 600 for all-indoor operation.

Operation on licensed bands extends from 4 to 38 GHz. Operation on the license-free 5.8 GHz ISM band is supported for North America and Canada.

Path, equipment, and data protection options support comprehensive link, network and data redundancy.

Plug-in cards on the INU and INUe provide a wide choice of user interfaces and link operation. Options include:

- IP/Ethernet
- Synchronous Ethernet
- E1/DS1
- E3/DS3
- STM1/OC3
- Fixed or adaptive modulation
- Hot-standby, space diversity, frequency diversity, dual diversity
- CCDP/XPIC (co-channel dual polarized with cross-pol interference cancellation)

The node-based concept eliminates most ancillary equipment and external cabling, and offers smooth upgrade paths for next generation networks.

Operation is supported by Portal and ProVision. Portal is a PC-based craft tool, ProVision is the element management system (EMS).

See:

- [Node Indoor Units on page 41](#)
- [Plug-in Cards on page 42](#)
- [Protection Options](#)
- [Eclipse Packet Node and Data Packet Plane on page 55](#)
- [Platforms on page 57](#)



**Figure 1.** INUe with High-Power 3RU IRU 600



**MEF Certified.** Eclipse Node and Packet Node meet MEF 9 and MEF 14 requirements for carrier-class Ethernet inter-operability and performance.

- MEF 9 specifies the User Network Interface (UNI)
- MEF 14 specifies Quality of Service (QoS)



**Aviat Networks is ISO90001:2008 and TL9000 Certified.** Full certification means all departments and business units within Aviat Networks have been strictly assessed for compliance to both standards. It testifies that Aviat Networks is a certified supplier of products, services and solutions to the highest ISO and Telecommunication standards available.

## Node Indoor Units

There are two indoor units, the INU, and INUe (extended INU). The INU is a 1RU chassis, the INUe 2RU chassis.

Mandatory plug-ins are the NCC (Node Control Card) and FAN (Fan card). The optional plug-ins include RAC (Radio Access Card), DAC (Digital Access Card), AUX (Auxiliary), NPC (Node Protection Card), and PCC (Power Converter Card).

## INU

The INU requires one NCC and one FAN, and has provision for four option plug-ins. It supports a maximum of three RFUs for three non-protected links, or one protected/diversity link and one non-protected link.

**Figure 2.** INU

## INUe

The INUe requires one NCC and one 2RU FAN, and has provision for ten option cards. It supports a maximum of six RFUs for six non-protected links, or up to three protected/diversity links.

**Figure 3.** INUe

## Plug-in Cards

Plug-in cards for the INU or INUe enable quick and easy customization on Eclipse configurations. All cards are hot-pluggable.

**RACs** support the radio modem function. In the transmit direction they take the digital traffic from the backplane or data packet plane and convert it to an IF signal for connection to an RFU (ODU or IRU 600). The reverse occurs in the receive direction.

- One RAC/ODU or RAC/IRU 600 combination is used for a 1+0 link.
- Two RAC/ODUs or two RACs with one 1+1 IRU 600 are used for 1+1 hot-standby or diversity links.
- RACs control TX switching and RX voting on protected / diversity links. Different RACs support different capacity and modulation options.

- XPIC (cross polarization interference cancellation) RACs support CCDP (co-channel dual polarization) operation.

**DACs** support the user interface.

- Different DACs support Ethernet, E1/DS1, E3/DS3, and STM1/OC3 connections.
- Multiplexer DACs support transport of STM1/OC3 or E3/DS3 *with* Nx E1/DS1 rates.
- Ethernet DACs support a L2 switch function. DAC GE3 supports advanced options for Synchronous Ethernet, ring/mesh protection, QoS, buffer management, link aggregation, VLAN tagging, and OAM.
- Most DACs can be protected using a stacked (paired) configuration.
- E1/DS1, DS3, and STM1/OC3 DACs support Ethernet-over-TDM options to enable Ethernet transport over legacy TDM radio or leased-line links.

**NCM** (Network Convergence Module) provides an E1/DS1 loopswitch capability.

**AUX** (Auxiliary card) supports async or sync service-channel connections, and alarm I/O options for connection to external devices.

**NCC** (Node Controller Card) provides Node management and DC-DC converter functions. NCC is a mandatory card.

- It manages Node operation and event collection and management.
- It incorporates a router function for local and remote network management interconnection.
- Node configuration and licensing data is held in flash-memory.
- Power supply: -48 Vdc (SELV -40.5 to -60 Vdc).

**FAN** (Fan card) provides forced-air cooling. FAN is a mandatory card.



**NPC** (Node Protection Card) provides 1+1 protection functions for the NCC power supply and backplane management.

**PCC** (Power Conversion Card) supports operation from a +24 Vdc power supply.

The figure below illustrates the nodal concept and the wide range of plug-in cards.

See [Plug-in Cards Overview on page 43](#) for an introduction to the cards and their functions.

## Plug-in Cards Overview

-  **NOTE:** RAC 60, RAC 6X, RAC 3X, RAC 30A, RAC 40, RAC 4X, DAC GE, DAC ES, DAC 16x are legacy plug-ins - they are no longer manufactured.
-  **NOTE:** For more detailed information on plug-ins refer to the [Eclipse Platform Product Description](#).

## RAC 70

RAC 70 supports DPP (Data Packet Plane) and ACM (Adaptive Coding and Modulation) options. RAC 70 additionally supports airlink recovered timing (ART) for high accuracy radio transport of a SyncE clock.

There are ten dynamically switched modulation rates; QPSK, 16 QAM, 32 QAM, 64 QAM, 128 QAM, 256 QAM, 512 QAM, 1024 QAM, 2048 QAM and 4096 QAM, (2048 QAM and 4096 QAM are only available with the ODU 600v2 or IRU 600v4).

- All of the modulation states offered with ACM can be selected for use.
- Modulation switching (state change) is errorless for priority traffic.

A DPP port enables direct routing of Ethernet traffic to a DAC GE3.

Payload encryption is a licensed option (this is the same license as for the RAC 60/6x/60E/6xE).

Individual ACM modulations can be set as fixed rates. These are complemented by fixed-only rates for TDM capacities (DS1). DS3 and OC3 are not supported by the RAC 70.

Channel bandwidths range from 10 to 80 MHz ANSI. Air-link capacities for Ethernet, or for Ethernet+TDM, extend to 715 Mbit/s. TDM options extend to 127xDS1.

ART operation is designed to meet G.8262 synchronization mask requirements for SyncE clock transport.

RAC 70 interfaces to an ODU 600, or to the IRU 600.

**Figure 4.** RAC 70



## RAC7X

RAC 7X adds CCDP operation to RAC 70 capabilities.

Two RAC 7X cards are operated as a CCDP pair, either in the same INU, or in separate co-located INUs to provide double the capacity over one channel, using both the horizontal and vertical polarizations. An XPIC function between the RACs ensures cross-polarization interference is eliminated.

**Figure 5.** RAC 7X

## RAC 60 and RAC 60E

RAC 60 supports DPP (Data Packet Plane) and ACM (Adaptive Coding and Modulation) options. RAC 60E additionally supports airlink recovered timing (ART) for high accuracy radio transport of a SyncE clock.

There are four dynamically switched modulation rates; QPSK, 16 QAM, 64 QAM, 256 QAM. Coding options additionally apply on each of these modulations, one for maximum throughput, one for maximum gain, to provide an effective total of eight modulation states.

- Maximum throughput delivers maximum data throughput - at the expense of some system gain.
- Maximum gain delivers best system gain - at the expense of some throughput.
- Up to four of the eight modulation states offered with ACM can be selected for use.
- Modulation switching (state change) is errorless for priority traffic.

A DPP port enables direct routing of Ethernet traffic to a DAC GE/GE3.

Individual ACM modulations can be set as fixed rates. These are complemented by fixed-only rates for TDM capacities (E1/DS1, DS3, STM1/OC3).

Channel bandwidths range from 5 to 56 MHz ETSI, and 3.5 to 80 MHz ANSI.

Air-link capacities for Ethernet, or for Ethernet+TDM, extend to 366 Mbit/s.

TDM options extend to 100xE1, 127xDS1, 4xDS3, 2xSTM1/OC3.

Payload encryption is a licensed option.

RAC 60E ART operation is designed to meet G.8262 synchronization mask requirements for SyncE clock transport.

RAC 60/60E interfaces to an ODU 600, ODU 300hp, or to the IRU 600.

A RAC 60 can link to a RAC 6X in non-CCDP mode, or to a RAC 6XE in non-CCDP, non ART modes.

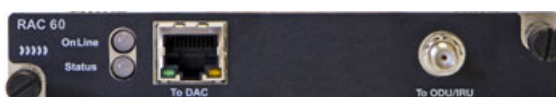
**Figure 6.** RAC 60

## RAC 6X and RAC 6XE

RAC 6X/6XE adds CCDP operation to RAC 60/60E capabilities. RAC 6XE additionally supports ART.

Two RAC 6X/6XE cards are operated as a CCDP pair, either in the same INU, or in separate co-located INUs to provide double the capacity over one channel, using both the horizontal and vertical polarizations. An XPIC function between the RACs ensures cross-polarization interference is eliminated.

A RAC 6X can link to a RAC 6XE where ART capability is not required.

**Figure 7.** RAC 6XE

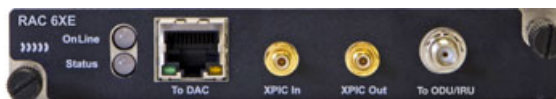

## DAC GE3

DAC GE3 capabilities include Synchronous Ethernet, link aggregation, policing, ring/mesh protection and Ethernet service OAM.

- Three RJ-45 10/100/1000Base-T ports
- Two multi-purpose SFP ports with plug-ins for:
  - Optical LC, 1000Base-LX, 1310 nm single-mode
  - Optical LC, 1000Base-SX, 850 nm multi-mode
  - Electrical RJ-45 10/100/1000Base-T
- Six transport channel (TC) ports
- Comprehensive QoS traffic prioritization and scheduling options:
  - 802.1p mapping
  - DiffServ mapping (IPv4, IPv6)
  - MPLS Exp bits mapping
  - Strict priority scheduling
  - Deficit Weighted-Round-Robin (DWRR) scheduling
  - Hybrid strict + DWRR scheduling
  - Eight transmission queues
- Traffic policing using TrTCM (two rate, three color metering) with remarking options
- L2 LAG (IEEE 802.1AX), static and LACP
- L1LA (Layer 1 link aggregation)
- Advanced options for VLAN tagging, including Q (802.1Q), QinQ (802.1ad), Filtering, Translation

- Synchronous Ethernet with Stratum 3 hold-over performance on timing subsystem
- RSTP (IEEE 802.1w)
- ERP (ITU-T 8032v2)
- Ethernet service OAM (IEEE 802.1ag/IYU-T Y.1731: ETH-CC, ETH-LB, ETH-LT)
- Data packet plane (DPP) and/or backplane traffic interconnection to RACs
- Advanced traffic shaping for fixed and adaptive modulation links
- Superior burst management with 1500 Kbytes shared memory across active ports
- Storm control
- Jumbo frames to 10 Kbytes bi-directional
- Flow control (IEEE 802.3x)
- 1+1 port and card protection
- Inter-frame gap (IFG) and preamble stripping and re-insertion
- RMON stats per port, channel, and queue
- Compatibility with DAC GE, DAC ES, IDU ES, IDU GE 20x, IDU GE3 16x

**Figure 8.** DAC GE3



For DPP traffic a DAC GE3 must be operated with a RAC 70/7X, RAC 60/60E or RAC 6X/6XE. RAC 60E/6XE/70/7X is required for Synchronous Ethernet links.

## DAC GE

DAC GE interfaces three 10/100/1000Base-T electrical ports and one 1000Base-LX optical port, to one or two transport channels. Features include:

- Traffic prioritization options
  - 802.1p mapping
  - DiffServ mapping (IPv4)
  - Four transmission queues
- Transparent, VLAN and mixed modes of operation
- Enhanced, fast-switched RSTP
- Layer 1 or Layer 2 link aggregation
- VLAN tagging, for Q and QinQ
- DPP and backplane traffic connections
- Inter-frame gap (IFG) and preamble stripping and re-insertion
- Frame sizes to 9600 bytes
- Assignment to radio or fiber links

- SFP optical port options for 1310nm single-mode, or 850nm multi-mode
- Compatibility with DAC GE3, DAC ES, IDU ES, IDU GE 20x, IDU GE3 16x

**Figure 9.** DAC GE



For DPP traffic a DAC GE must be operated with a RAC 60/60E or RAC 6X/6XE.

## DAC ES

DAC ES interfaces four 10/100Base-T Ethernet ports to one or two radio and/or fiber transport channels. Features include:

- Advanced QoS settings
- Transparent, VLAN and mixed modes of operation.
- Throughputs to 100 Mbit/s per transport channel
- Assignment to radio or fiber links
- Inter-frame gap (IFG) and preamble stripping and re-insertion
- Compatibility with DAC GE3, DAC GE, IDU ES, IDU GE 20x, IDU GE3 16x

**Figure 10.** DAC ES



## DAC 16X

DAC 16x supports 16xE1 or 16xDS1 tributaries on Mini RJ-21 connectors.

**Figure 11.** DAC 16x



## DAC 16xV2/V3

DAC 16xV2/V3 supports 16xE1 or 16xDS1 tributaries on compact HDR connectors.

The DAC 16xV3 is compatible with and can be safely used in all cases with the DAC 16xV2, over the air, and in applications like NCM/SPDH/NTU, where a same DS1 can be inserted via a DAC16xV3 card(s) in one INU and then dropped on the facing side of the hop (or at an INU further down in the network) via DACxV2 card(s), and vice-versa.

**NOTE:** An INU with a protected pair of DAC16xV3 cards can interface over the air with an INU equipped with a protected pair DAC16xV2 to carry the same DS1's.



Features additional to those provided by DAC 16x include:

- Tributary protection
- Ethernet over E1/DS1 tribs
- Individual line code selection for AMI or B8ZS on DS1 tribs

**Figure 12.** DAC 16xV2



## DAC 4X

DAC 4x supports 4xE1 or 4xDS1 tributaries on individual RJ-45 connectors. It also supports E1 waysides on the STM1+1E1 link option.

**Figure 13.** DAC 4X



## DAC 3xE3/DS3

DAC 3xE3/DS3 supports 3xE3 or 3xDS3 tributaries on paired mini-BNC connectors.

**Figure 14.** DAC 3xE3/DS3



## DAC 3xE3/DS3M

DAC 3xE3/DS3M supports four operational modes:

- Normal E3/DS3 tributary operation (as for DAC 3xE3/DS3)
- E13 multiplexer mode. One or two E3 interfaces are multiplexed to an Nx E1 backplane.
- M13 multiplexer mode. One or two DS3 interfaces are multiplexed to an Nx DS1 backplane.
- 34 Mbit/s transparent E3 mode for video (MPEG) transport. One or two transparent E3 tributaries are each mapped to a 34xE1 backplane.
- DS3 Ethernet mode to enable up to 43 Mbit/s Ethernet over legacy TDM radio or leased-line links (links must support transparent DS3).

Tribes are supported on paired mini-BNC connectors.

**Figure 15.** DAC 3xE3/DS3M

## DAC 2x155e

DAC 2x155e supports two STM1 electrical tributaries on paired BNC connectors.

**Figure 16.** DAC 2x155e

## DAC 1x155o

DAC 1x155o supports one STM1/OC3 single-mode optical tributary on SC connectors.

**Figure 17.** DAC 1x155o

## DAC 2x155o

DAC 2x155o supports two STM1/OC3 single-mode optical tributaries on SC connectors.

**Figure 18.** DAC 2x155o

## DAC 155oM

DAC 155oM multiplexes an STM1/OC3 optical tributary to an NxE1 or NxDS1 backplane. The user interface is provided on an SFP optical transceiver. Different SFPs support 1310nm single-mode, or 850nm multi-mode.

It functions as a terminal multiplexer; it terminates or originates the STM1/OC3 frame. It does not support interconnection of ADMs as there is no provision to transport STM1/OC3 overheads for ADM to ADM synchronization.

In virtual tributary mode it transports up to 130 Mbit/s Ethernet over an STM1/OC3 link.

Options are provided for external/recovered, or internal clock sourcing.

**Figure 19.** DAC 155oM

## DAC 155eM

DAC 155eM multiplexes an STM1/OC3 electrical tributary to an NxE1 or NxDS1 backplane. The user interface is provided on an SFP electrical transceiver.

It functions as a terminal multiplexer; it terminates or originates the STM1/OC3 frame. It does not support interconnection of ADMs as there is no provision to transport STM1/OC3 overheads for ADM to ADM synchronization.

In virtual tributary mode it transports up to 130 Mbit/s Ethernet over an STM1/OC3 link.

Options are provided for external/recovered, or internal clock sourcing.

**Figure 20.** DAC 155oM

## NCM

NCM provides an NxE1/DS1 loop switch capability. At ring nodes it is configured to access redundant east and west traffic streams for data input (insert) and output (drop).

- Traffic inserted into a local tributary is transmitted on both east and west facing streams to create a bi-directional ring.
- A local drop selection is made on these east and west streams on the receive direction to use.
- Operation applies on either framed or unframed E1/DS1 tributaries.
- The operational mode is low latency, non-hitless.

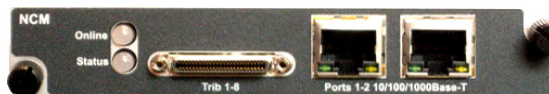
**Figure 21.** NCM

## AUX

AUX provides synchronous and/or asynchronous auxiliary data channels, NMS porting, and alarm input and output functions. Data options are sync at 64 kbps or async to 19.2 kbps.

**Figure 22.**

## NCC

The NCC is a mandatory plug-in for an INU/INUe. It performs key node management and control functions, and provides various dc rails from the -48 Vdc input. It also incorporates a plug-in flash card, which holds Node configuration and license data.

Power input limits are -40.5 to -60 Vdc. The power connector is a D-Sub M/F 2W2. The +ve dc return pin is connected to chassis ground.

**Figure 23.** NCC



## FAN

The FAN is a mandatory plug-in. There are two variants, 2RU and 1RU. Each is fitted with two long-life axial fans plus monitoring and control circuits.

One 1RU FAN is fitted in an INU.

One 2RU FAN or two 1RU FANs are fitted in the INUe. The 2RU FAN is standard.

**Figure 24.** FAN (1RU)



## NPC

NPC provides redundancy for the NCC backplane bus management and power supply functions.

**Figure 25.** NPC



## PCC

The PCC provides a voltage conversion function for use at locations where the power supply is +24 Vdc. It converts +24 (19 to 36) Vdc to -56 Vdc for connection to the INU -48Vdc input. -56 Vdc represents the typical float voltage for a battery-backed -48 Vdc supply.

One PCC supports:

- Up to a 200W in air-conditioned installations (ambient max 25<sup>0</sup>C / 77<sup>0</sup>F).
- Up to a 150W in non-air-conditioned installations (ambient max 45<sup>0</sup>C / 113<sup>0</sup>F).

**Figure 26.** PCC



## Protection Options

The Nodes offer link, interface, network, and platform protection options:

### Link/Path Protection

Hot-standby, space diversity, frequency diversity, or dual protection options are available. All RACs and their companion ODU or IRU 600 are protectable.

RAC 70/7X does not support frequency diversity protection.

Rx path switching (voting) is hitless/errorless; Tx switching is not hitless.

A remote Tx switch is forced in the event of a silent Tx failure.

### Interface Protection

Ethernet, E1/DS1, E3/DS3 and STM1/OC3 interfaces can be hot-standby protected using paired (stacked) DACs.

The protectable DACs are DAC GE3, DAC 16x V2/V3, DAC E3/DS3, DAC 3xE3/DS3M, DAC 155o, DAC 2x155o, DAC 2x155e, DAC 155oM, DAC 155eM.

The NCM is also protectable using paired NCMs.

### TDM Interfaces

For TDM DACs and for NCM front panel tributaries two interface protection configurations are supported, tributary protection and always-on:

#### Tributary Protection

- Y-cables connect the paired DACs/NCMs to customer equipment. (Y-cable protection is not supported for DAC 155eM).
- In the Rx direction (from the customer) both DACs/NCMs receive data, but only the online Rx DAC/NCM sends this data to the backplane bus.
- In the Tx direction, the online Tx DAC/NCM sends data to customer equipment, the other mutes its Tx line interface.
- The connected equipment is not involved in the protection process.

### **Tributary Always-On**

- Separate cables connect each DAC/NCM to customer equipment.
- In the Rx direction (from the customer) both DACs/NCMs receive data, but only the online Rx DAC/NCM sends this data to the backplane bus.
- In the transmit direction both DACs/NCMs send data to customer equipment, and the customer equipment switches between these two always-on tributaries.
- Protection switching is not hitless. Typical restoration times are between 80 ms and 120 ms.

## **Network/Data Protection**

Ethernet ring and ladder network protection is provided using RSTP or ERP options.

Ethernet data redundancy is provided on link-aggregated links using L1 or L2 options.

PDH ring network protection is provided using Eclipse E1/DS1 Loopswitch or Super PDH (SPDH™) configurations.

### **Ethernet Ring and Ladder Networks**

Eclipse DAC GE3 supports two ring protection mechanisms, Ethernet Ring Protection (ERP, ITU-T G.8032v2) and RSTP (IEEE 802.1w).

ERP is a fast-acting automatic protection switching (APS) protocol for Ethernet ring topologies. Features include:

### **Ethernet Link Aggregation Protection**

Traffic redundancy is supported on co-channel Ethernet links using L1 or L2 link aggregation options. If one link fails, its traffic is recovered on the remaining link or links. While the reduced bandwidth may result in some traffic loss for low-priority traffic, appropriate QoS settings can be used to ensure security for all higher priority traffic.

### **Loop Switch Ring Protection**

Loop switch operation employs the NCM for ring capacities to 50xE1 or 63xDS1, with traffic switching at the local node level.

Operation is based on redundant east/west facing rings.

- Traffic inserted into a local tributary is transmitted in east and west directions to create a bi-directional ring.
- At a drop site traffic is selected from either the east or west direction. If the selected direction fails, the opposite direction is automatically switched into service.
- One or more radio paths can be replaced by a fiber or coax span using the DAC

155oM or DAC 3xE3/DS3M.

- The operational mode is low latency, non-hitless.

## Super PDH Ring Protection

Super PDH™ supports ring capacities to 64xE1 or 84xDS1, with traffic switching at the node level using a ring wrapping technique.

Operation is based on east/west facing rings, one nominated as clockwise, the other anti-clockwise.

- Under normal no-fault conditions, all traffic is passed on the clockwise primary ring.
- When a fault occurs, the secondary, anti-clockwise ring, provides the protection capacity needed. Traffic is looped onto the secondary ring at one side of the break point, and off at the other side, to bypass the break.
- One or more radio paths can be replaced by a fiber span using the DAC 155oM.
- Operation is not hitless.

## Platform Protection

Platform management functions provided by the NCC are protected using the NPC option to protect essential backplane bus and power supply functions.

- Bus protection protects all circuit/tributary traffic (alarm I/O is not protected).
- Power supply protection protects against an NCC power supply failure. If the NCC converter or one of its supply rails fails, the NPC will take over without interruption - and vice versa.

## Eclipse Packet Node and Data Packet Plane

### Data Packet Plane

DPP operation is enabled via direct cable connection between the front panel packet data port on a RAC 70, RAC 60/60E, RAC 6X/6XE, and a front-panel port on a DAC GE3/GE. Customer traffic connected to the DACs is bridged to the RACs, and then to the RF transceiver; the split-mount ODU 300hp or ODU 600, or the all-indoor IRU 600.

Where required, customer data can also be sourced via the circuit-switched backplane, meaning both the DPP and backplane can be used to source/send traffic. This has special relevance where native mixed-mode IP + TDM traffic is to be sent over a Packet Node wireless link; GigE IP traffic via the DPP, and TDM traffic via the backplane.

## Advanced Adaptive Coding and Modulation (ACM)

Advanced ACM options are provided using RAC 70, RAC 60/60E or RAC 6X/6XE plug-ins.

- Adaptive modulation maximizes use of available channel bandwidth.
- Coding is used to extend throughput granularity by providing maximum throughput or maximum system gain options on each adaptive modulation rate.
- ACM operation requires a 2.048 or 1.544 Mbps Bus Connection Size.

### RAC 70 Adaptive Modulation (AM)

AM uses one of ten automatically and dynamically switched modulations - QPSK, 16 QAM, 32 QAM, 64 QAM, 128 QAM, 256 QAM, 512 QAM, 1024 QAM, 2048 QAM or 4096 QAM. For a given RF channel bandwidth a two-fold improvement in data throughput is provided for a change from QPSK to 16 QAM, a three-fold improvement to 64 QAM, and a four-fold improvement to 256 QAM.

The adaptive modulation engine ensures that the highest modulation and hence highest throughput is always provided based on link quality.

Modulation switching is hitless/errorless.

Ethernet connections enjoy real synergy through the QoS awareness on the DAC GE3 GigE switch, and the service provisioning provided by any MPLS or PBB-TE network overlay.

- All high priority traffic, such as voice and video, continues to get through when path conditions are poor and modulation/capacity is reduced.
- When path conditions are normal (good) best-effort lower priority traffic, such as email and file transfers, enjoy data bandwidths that can be up to four times the guaranteed (QPSK) bandwidth.

While adaptive modulation can also be used on PDH links and combined PDH and Ethernet links, unlike Ethernet there is no QoS synergy on PDH connections.

- E1/DS1 connections are dropped in user-specified order when link capacity is reduced, and restored when capacity is increased.

### Coding

Modulation code options provide two sets of modulation states, one for maximum throughput, the other for maximum gain. These apply on each of the modulation rates (QPSK, 16 QAM, 64 QAM, 256 QAM) to provide a total of eight modulation states.

Maximum throughput delivers maximum data throughput - at the expense of some system gain.

Maximum gain delivers best system gain - at the expense of some throughput.



Up to four of the eight modulation states offered with ACM can be selected for use. For example:

- With four modulation rates, each can be set for maximum throughput or maximum gain.
- With three modulation rates, such as 16 QAM, 64 QAM, 256 QAM, *one* rate (any) can be set for maximum gain and additionally for maximum throughput, to provide four step AM operation.
- With two modulation rates, such as 16 QAM (or 64 QAM) with 256 QAM, each can be set for maximum gain and additionally for maximum throughput, to provide four step AM operation.

This feature provides a practical trade-off between capacity and system gain to fine-tune link performance. It provides best balance on AM operation.

- The four modulation rates support near-linear 2x, 3x, 4x capacity steps.
- The coding options allow capacity/gain variations on these rates to always support up to four steps, even when just two of the possible four modulation rates are in use, or are permitted.
- Even where just one modulation rate is required/permitted, the coding option supports two-step AM operation, one for maximum throughput, one for maximum gain.

## Platforms

Eclipse supports flexible customization of traffic type, traffic capacity, and traffic protection for up to three links using the INU, and to six links using the INUe.

For slot location and usage, cross-connects, capacity, and RAC/RFU parameters see:

[Platform Layout on page 57](#)

[Slot Assignments on page 58](#)

[Platforms on page 57](#)

## Platform Layout

The following table lists INU and INUe platform support for:

- Non-protected and protected/diversity links
- Slot availability for option plug-ins
- Over-air data types supported
- ODU and IRU 600 options

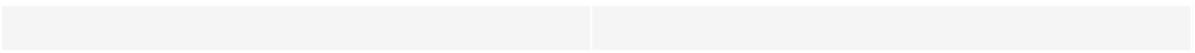

**INU**

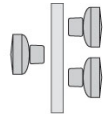

Supports 3 non-protected links or 1 protected/diversity and 1 non-protected link.

**INUe**

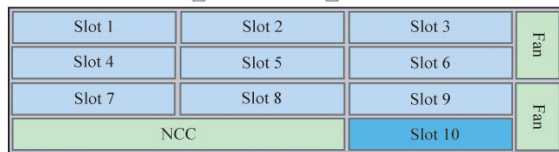
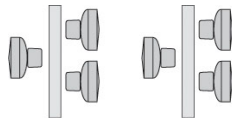

Supports up to 6 non-protected links for:  
 1 protected/diversity and 4 non-protected links, or  
 2 protected/diversity and 2 non-protected links, or  
 3 protected/diversity links.

**IRU 600**



**IRU 600:**

QPSK to 256 QAM, 4 to 11 GHz ANSI licensed bands, 5.8 GHz ISM band (USA and Canada).

Requires RAC 60/RAC 6X or RAC 60E/6XE. Fixed or adaptive modulation rates.

1+1 optimized.

Extra-high Power, high-power, standard power RFU options.

Three variants: V1, V2, V3. V1 and V2 are 3RU. V3 is 2RU. V2 and V3 incorporate a Tx coaxial switch for HSB and MHSB/SD operation. (V1 is discontinued).

## Slot Assignments

**INU/INUe** **Slots**

**INU**

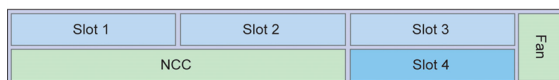

Slots 1, 2, 3, 4 are universal: any RAC, DAC, NCM, or AUX plug-in

Slot 4 is NPC or universal: NPC or any RAC, DAC, NCM, AUX

NCC and FAN slots are dedicated

For protected operation the RAC/RAC, RAC/DAC 155oM, NCM/NCM, or DAC/DAC pairings can be installed in any of the universal slots

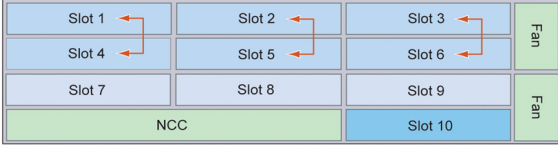
INU/INUe	Slots
<p><b>INUe</b></p>  <p>The diagram shows a 3x3 grid of slots. The top row contains Slot 1, Slot 2, and Slot 3. The middle row contains Slot 4, Slot 5, and Slot 6. The bottom row contains Slot 7, Slot 8, and Slot 9. To the right of Slot 7 and Slot 8 is a vertical column labeled 'Fan'. Below Slot 7, Slot 8, and Slot 9 is a horizontal row labeled 'NCC'. Below Slot 10 is a horizontal row labeled 'NCC'. Red arrows point from Slot 1 to Slot 2, Slot 2 to Slot 3, Slot 4 to Slot 5, and Slot 5 to Slot 6. A red arrow also points from Slot 6 to Slot 7. Another red arrow points from Slot 8 to Slot 9. A red arrow points from Slot 10 to Slot 7.</p>	<p>Slots 1, 2, 3, 4, 5, 6 are universal: any RAC, DAC, NCM, or AUX plug-in</p> <p>Slots 7, 8, 9 are restricted: any DAC, NCM, or AUX, except DAC 155oM/eM and AUX <i>where NMS access is required</i><sup>1</sup></p> <p>Slot 10 is restricted: NPC option only</p> <p>NCC and FAN slots are dedicated - the INUe is supplied standard with a single 2RU FAN, though accepts two 1RU FANs</p> <p>RAC/RAC, or RAC/DAC 155oM/eM protected pairings must be installed in the positions indicated by the arrows</p> <p>For protected DACs or NCMs, the protection partners can be installed in slots 1 to 9, except for the DAC 155oM/eM where NMS access is needed, in which case install only in slots 1 to 6</p>

---

<sup>1</sup>Internal (backplane bus) NMS access is only provided on slots 1 to 6. Do not install DAC 155oM, DAC 155eM, or AUX in slots 7 to 9 if an NMS connection is required in their configuration.

# Eclipse Terminals

---

Eclipse Terminals (IDUs) are single-link radios. For network (multi-link) applications they are back-to-back connected via their tributary ports at intermediate sites. Most can be paired for protected link operation.

IDUs may also be over-air interfaced to like IDUs of higher or lower ultimate capacity and, with the exception of the IDUsp, to Eclipse Node.

All IDUs support split-mount installation; only IDU GE3 16x supports split-mount or all-indoor.

 **NOTE:** All IDUs with the exception of IDU GE3 16x and IDU 155o are legacy IDUs (no longer manufactured).

Refer to:

[300 Series Indoor Units on page 60](#)

[Eclipse Radio Frequency Units on page 67](#)

**Figure 27.** Eclipse Terminal



## 300 Series Indoor Units

IDU 300 variants support Ethernet, PDH, SDH, on ETSI and ANSI bands.

**Table 4.** Current IDU 300 Variants

Application	Variant	Capacities	Modulation
<b>E1/DS1 only</b>	IDU 300 20xV2	5x, 10x, 20x, 32x, 40xE1, or 4x, 8x, 16x, 28x, 32xDS1	QPSK to 128QAM
	IDUsp 4x	4xE1	QPSK
	IDUsp 16x	4x, 8x, 16xE1	QPSK
<b>STM1/OC3</b>	IDU 155o	STM1/OC3	16/64/128QAM
<b>Ethernet with E1/DS1 tributary options</b>	IDU ES	Airlink capacities to 200 Mbps with up to 8xE1/DS1 tribs. Ethernet interfaces: 4x 10/100Base-T.	QPSK to 256QAM
	IDU GE 20x	Airlink capacities to 360 Mbps and up to 20xE1/DS1 tribs. Ethernet interfaces: 2x 10/100/1000Base-T plus 2x SFP slots for 1000Base-LX optical 1310nm, 1000Base-SX optical 850nm, or 1000Base-T electrical.	QPSK to 256QAM
	IDU GE3 16x	Airlink capacities to 366 Mbps and to 16xE1/DS1 tribs. Ethernet interfaces: 4x 10/100/1000Base-T plus 2x SFP slots for optical or electrical transceiver options.	QPSK to 256QAM with fixed or adaptive modulation

Split-mount ODU options support operation on bands 5 to 38 GHz.

All-indoor IRU 600 options support operation on ANSI bands L6 to 11 GHz, or 5.8 GHz unlicensed band (USA and Canada only), *with IDU GE3 16x only*.

## IDU 300 Series Overview

IDUs, except for IDUsp, can be over-air interfaced to an Eclipse Node. This applies only to non-protected 1+0 link operation. **Where 1+1 IDU operation is required, protected IDUs must be installed at both link ends.**

### IDU GE3 16x

IDU GE3 16x is a state-of-art sub-compact radio terminal for all-IP and hybrid wireless backhaul. Its internal modules comprise relevant RAC 60E, DAC GE3, DAC 16xV2, AUX and NCC functions of Eclipse Node. Features include:

- Split-mount with ODU 300 or ODU 600 on licensed bands 5 to 38 GHz
- All-indoor with IRU 600 on ANSI licensed bands 4 to 11 GHz
- All-indoor with IRU 600 on license-free 5.8 GHz ISM band (USA, Canada, only)
- 256 QAM adaptive modulation
- Extensive IP traffic management and monitoring capabilities
- Packet-synchronization options
- Flexible IP or hybrid IP+PDH link operation
- Broad diagnostic functions
- Sub-compact, 1/2RU rack-print

- Low power consumption (less than 30W) for simplified power supply and cooling management
- Auxiliary data and alarm I/O options
- Inter-operation with Eclipse Packet Node
- Optional NEBS compliance

RFU options are the ODU 300hp or ODU 300sp for split-mount operation, or the IRU 600 for all-indoor.

**Figure 28.** IDU GE3 16x



Capacity is licensed. Feature licenses apply to adaptive modulation, synchronous Ethernet, TDM tributary access, advanced QoS.

### Adaptive or Fixed Modulation

Fixed and adaptive modulation options are available.

Adaptive modulation enables automatic adjustment of modulation and/or coding so that the most data efficient (highest possible) modulation is used over the prevailing path conditions.

- Adaptive modulation refers to the dynamic adjustment of modulation rate.
- Coding refers to an ability to set individual modulation rates for maximum throughput, or maximum system gain.

IDG GE3 supports four modulation rates, QPSK, 16 QAM, 64 QAM, or 256 QAM, plus a coding option on each for a total of eight modulation states. Plus any of the modulation states can be separately selected for fixed operation.

### Hot Standby or Diversity Protection

Paired IDUs support 1+1 hot standby or space diversity operation.

Ethernet and E1/DS1 interface protection options are enabled with protected IDUs.

### Carrier Class Ethernet Features

The Gigabit L2 switch capabilities include Synchronous Ethernet, 1+1 interface protection, and superior packet buffering and queuing.

- 6 user ports; 4x RJ-45; 2x SFP with optical or electrical transceiver options
- 8 priority queues per port
- 1+1 interface protection on protected IDUs
- Port and protocol-based priority assignment (MPLS Exp, DSCP, 802.1p)
- TrTCM traffic policing
- Strict, DWRR (Deficit Weighted Round Robin), and Hybrid scheduling modes
- VLAN tagging, untagging, filtering, and translation
- Synchronous Ethernet

- Layer 2 link aggregation, IEEE 802.1AX static and dynamic (LACP)
- Ring/mesh Protection, ERP (ITU-T G.8032v2) and RSTP (IEEE 802.1w)
- Ethernet Service OAM (IEEE 802.1ag, and ITU-T under Y.1731)
- Storm control
- Flexible allocation of 1500 Kbytes of buffer memory.
- Jumbo frames to 10 Kbytes bi-directional
- Flow control
- IFG and Preamble suppression

An IDU GE3 16x 1+0 terminal can be over-air interfaced to an Eclipse Packet Node comprising the INU, RAC 60/60E, DAC GE3 (or DAC GE, DAC ES) with ODU 600, ODU 300hp or IRU 600. Where E1 or DS1 side channels are required, a DAC 16xV2 should be installed in the INU. Similarly an AUX is installed where external Alarm I/O interfaces are required.

For protected IDU GE3 16x operation, both ends of the link must be IDU GE3 16x.

## IDU 155o

IDU 155o supports a single 155 Mbps STM1/OC3 tributary on optical SC connectors. Modulations options are 16, 64 or 128 QAM.

**Figure 29.** IDU 155o



IDUs are paired to support 1+1 hot-standby or space diversity operation. Optical Y cables are used to provide common Tx and Rx interfaces.

Tx switching is not hitless.

Rx switching (voting) is hitless (errorless).

Synchronous or asynchronous auxiliary data and alarm I/O options are included.

Requires ODU 300hp or ODU 300ep.

IDU 155o can be over-air interfaced to an Eclipse Node comprising the INU, DAC 155o, 2x155o, or 2x155e, and ODU 300. An AUX is installed where auxiliary channel services are also required. This applies only to non-protected 1+0 link operation. Where 1+1 IDU operation is required, protected IDUs must be installed at both link ends.

## IDU300 20xV2

IDU 300 20xV2 supports 20 tributaries on individual RJ-45 connectors for E1 or DS1 operation, modulation options to 128 QAM, and over-air capacities to 40xE1 or 32xDS1.

Features include:

Capacities to 20xE1 / 16xDS1 for single link non-protected operation.

Capacities to 20xE1 or 16xDS1 for hot-standby or space diversity operation.

Capacities to 40xE1 or 32xDS1 for hot-standby operation.

IDUs are paired for protected/diversity operation.

For capacities to 20xE1 / 16xDS1 normal IDU equipment and path protection applies, with Y cables used on the tribs.

For higher capacities, traffic from the standby IDU is routed to the online IDU to support termination of up to 40xE1 or 32xDS1 tribs. In this configuration tributary and PSU protection is not supported, however RAC/ODU and path protection functions are retained.

Tx switching is not hitless.

Rx path switching (voting) is hitless (errorless) for capacities to 20xE1 / 16xDS1. It is not hitless when configured for 40xE1 / 32xDS1 operation.

**Figure 30.** IDU 300 20xV2



IDU 300 20xV2 is capacity licensed. The base configuration supports 20xE1/16xDS1, with capacities to 40xE1 or 32xDS1 obtained by requesting additional capacity upgrades at time of order or as field-downloadable software licenses. See [Licensing](#).

Synchronous or asynchronous auxiliary data and alarm I/O options are included.

Requires ODU 300hp, ODU 300ep, or ODU 300sp.

IDU 300 20xV2 can be over-air interfaced to an Eclipse Node comprising the INU, DAC 16x and ODU 300. An AUX is installed where auxiliary channel services are also required. This applies only to non-protected 1+0 (20xE1 / 16xDS1 max) link operation. Where 1+1 IDU operation is required, protected IDUs must be installed at both link ends.

## IDUsp 16x and IDUsp 4x

These IDUs are cost optimized for basic E1 services:

IDUsp 4x: 4xE1 with QPSK modulation.

IDUsp 16x: 4x, 8x, 16xE1 with QPSK modulation.

**Figure 31.** IDUsp 16x



Paired IDUsp 16x IDUs support hot-standby operation; Tx and Rx switching is not hitless. The IDUsp 4x is not protectable.

A single 64 kb synchronous auxiliary data connection is included; there is no alarm I/O.

IDUsp requires an ODU 300sp or ODU 300hp; ODU 300ep is not supported.





Switch features include RWPR (Resilient Wireless Packet Ring), layer 2 link aggregation, and comprehensive QoS options with VLAN tagging and jumbo frame support.

Depending on the required Ethernet throughput, channel bandwidth ranges from 7 to 56 MHz ETSI, and 5 to 80 MHz ANSI, with modulation options from QPSK to 256 QAM. Maximum Ethernet throughput is 360 Mbps using one or both transport channels.

Configured link capacity may be assigned to Ethernet, or between Ethernet and up to 20xE1 or 20xDS1 side circuits, or to E1 or DS1 circuits only to a maximum of 20xE1 or 16xDS1.

Inter-frame gap (IFG) and preamble stripping and re-insertion is used to maximize data throughput.

Capacity is licensed. The base configuration (no license required) supports 20xE1 or 20xDS1 circuits. The licensed extensions enable Ethernet in steps to 50, 100, 150, 200, or 360 Mbps, each with up to 20xE1 or 20xDS1 waysides. See [Licensing](#).

Protected 1+1 hot-standby or space diversity operation is configured by adding a second IDU GE 20x. Ethernet traffic is supported on a single interface to one of the IDUs. E1/DS1 traffic is supported on interfaces to both IDUs using Y-cables.

The 1RU IDU GE 20x complies with ETSI half-rack mechanical specifications with a rack depth of 240 mm (9.4”).

**Figure 33.** IDU GE 20x



IDU GE 20x is also available in a 'Connect' link package, where a package comprises two terminals, each with one IDU GE 20x, and one ODU 300 outdoor unit, which depending on the required throughput and band, can be ODU 300sp, hp or ep.

Alarm I/O options are included.

An IDU GE 20x 1+0 terminal can be over-air interfaced to an Eclipse Node comprising the INU, RAC 30 or RAC 3X, DAC GE or DAC ES, and ODU 300. Where E1 or DS1 side channels are required, a DAC 4x or DAC 16x is also installed. Similarly an AUX is installed where external Alarm I/O interfaces are required.

For protected IDU GE 20x operation, both ends of the link must be IDU GE 20x.

# Eclipse Radio Frequency Units

---

ODUs support split-mount installations. A rack-mounting IRU 600 is installed for all-indoor installation.

## IRU 600

The IRU 600 is a rack-mounted transceiver unit for co-location with an INU/INUe as an all-indoor installation.

- IRU 600 is 1+1 optimized. It comprises one or two RFUs (radio frequency units), and a filter-based ACU (antenna coupler unit).
  - The ACU design supports paired and unpaired Tx/Rx frequency splits and incorporates an optional expansion port to allow other radio links onto its waveguide feed for co-path operation.
  - Protected/diversity options include:
    - 1+1 hot-standby
    - 1+0 hot-standby-ready
    - Space diversity (dual antennas) with common or split Tx
    - Frequency diversity (single antenna) or frequency diversity with space diversity (dual antennas)
  - 1+0 repeater (back-to-back) single chassis operation is supported. The links may be in the same or different bands.
  - 2+0 (or 2+2 using dual IRU 600 chassis) single antenna.
- Operation encompasses ANSI 4/L6/U6/UU6, 7/8, 10, 11 GHz licensed bands, and the FCC / Industry Canada 5.8 GHz unlicensed (ISM) band.
  - IRU 600v2 has been supplied for the 4/L6/U6, 7/8, 10 and 11 GHz licensed bands, and 5.8 GHz unlicensed band.
  - With the introduction of IRU 600v3/v4:
    - IRU 600v3/v4 is supplied on bands 5.8, L6/U6/UU6, 11 GHz.
    - IRU 600v2 is supplied on all bands 7/8, 10 GHz.
- Fixed or adaptive modulation profiles are supported.
- IRU 600 is only supported from a RAC 70, RAC 60/6X, or RAC 60E/6XE.
- When multiple IRU 600 links are combined onto a single waveguide feed for ACCP operation, required minimum Tx to Tx and Rx to Rx spacings, and minimum Tx to Rx separations must be strictly maintained. For information on ACCP operation

and limitations contact Aviat Networks or your supplier.

- EMI filtering is NEBS compliant.



**NOTE:** Unless otherwise stated, reference to IRU 600 refers to all IRU 600 variants.

## IRU 600 Variants

There are four variants: IRU 600v4, IRU 600v3, IRU 600v2, IRU 600(v1). IRU 600(v1) is discontinued.

### IRU 600v4

**Figure 34.** IRU 600v4 Front and Side Views



IRU 600v4 is available with two RFU variants, one for Standard Tx power (SP) or High Tx power (HP), and one for Extra High Tx power (EHP).

### IRU 600v3/v4

IRU 600v3/v4 is available with two RFU variants, one for standard Tx power (Std) or high Tx power (HP), and one for extra high Tx power (EHP).

### IRU 600v2 and IRU 600(v1)

Both support two RFU variants, a standard Tx power (Std) RFU, and a high Tx power (HP) RFU.

## Tx Coaxial Switch: IRU 600v4, IRU 600v3 and IRU 600v2

Primary benefits of the Tx coaxial switch are reduced power loss and faster Tx protection switch times.

- It avoids the losses associated with a Tx coupler/combiner.
  - With the Tx coaxial switch (relay) there is no A-side versus B-side consideration required as the loss is not more than 0.5 dB on both. See [ACU Losses, IRU 600 on page 1](#).
- For details on average recovery times, see Appendix G.

MHSB mode increases power consumption as both transmitters are fully active - both online and offline Tx status is captured in real time. Where lower power consumption is the priority, an option is provided to mute the offline Tx. For power consumption data See [INU Power Supply](#).

- With MHSB operation both A-side and B-side transmit are fully monitored in real time.
- With a Tx mute configured on the offline Tx, its Tx status can be monitored through a health monitoring facility whereby the Tx is turned on, checked and turned off again. The turn-on period is adjustable between 0 (no health monitoring) and 240 in 1 hour increments.
- The Mute Tx Offline selection is made in the RAC 70, RAC 60/60E/6x/6XE plug-ins screen.

## RFUs

### RFUv4 (IRU 600v4)

- There are two RFU variants, standard/high Tx power (SP/HP), and extra high Tx power (EHP):
  - An HP feature license is required to enable high Tx power on the SP/HP RFU.
  - No feature license is required for the EHP RFU, the EHP capability is inclusive.
- The DC supply for the SP/HP RFU is provided via the INU cable.
- The EHP RFU is additionally powered via a front-panel D-Sub M/F 2W2 connector for wide-mouth +/- 21 to 60 VDC supply. Both +ve and -ve pins are isolated from ground.
  - The power connector (D-Sub M/F 2W2) and cable is identical to that used for the INU.
  - The integral DC/DC converter provides polarity protection, under/over voltage

shutdown, over-current limit, and thermal shutdown.

- For operation from +24 VDC supplies, the associated INU/INUe can be fitted with a PCC to convert +24 VDC to - 48 VDC. Otherwise a suitable external converter can be used - contact Aviat Networks for details.
- Protected operation for MHSB and MHSB/SD configurations uses a Tx coaxial switch and an Rx coupler. Switch connection is via a DIN5 connector.
  - The DIN5 connector is located on the right side of the RFUs together with the SMA connector for RF cable connection to the ACU/Coax switch.
- INU (RAC 70, RAC 60E/6XE) connection is via a front panel SMA connector. An SMA-to-SMA cable is included with each RFU.
- RSSI access is provided on the front panel as meter test-probe points. Metal dot on right of RFU for ground.
- The RFU is 1RU, half-width.
- A front panel tri-color status LED indicates:
  - Red flashing during boot-up
  - Green for normal operation
  - Red when in an alarmed state
  - Orange when in standby mode (standby Tx RFU in an MHSB or MHSB/SD pairing)
- Includes three software-controlled, individually alarmed, cooling fans.

### **RFUv3 (IRU 600v3/v4)**

- There are two RFU variants, standard/high Tx power (Std/HP), and extra high Tx power (EHP):
  - An HP feature license is required to enable high Tx power on the Std/HP RFU.
  - No feature license is required for the EHP RFU, the EHP capability is inclusive.
- The DC supply for the Std/HP RFU is provided via the INU cable.
- The EHP RFU is *additionally* powered via a front-panel D-Sub M/F 2W2 connector for wide-mouth +/- 21 to 60 Vdc supply. Both +ve and -ve pins are isolated from ground.
  - The power connector (D-Sub M/F 2W2) and cable is identical to that used for the INU.
  - The integral DC/DC converter provides polarity protection, under/over voltage shutdown, over-current limit, and thermal shutdown.
  - For operation from +24 Vdc supplies, the associated INU/INUe can be fitted with a PCC to convert +24 Vdc to - 48 Vdc. Otherwise a suitable external converter can be used - contact Aviat Networks for details.
- Protected operation for HSB and HSB/SD configurations employs a Tx coaxial switch and an Rx coupler. Switch connection is via a DIN5 connector.

- The DIN5 connector is located on the right side of the RFUs together with the SMA connector for RF cable connection to the ACU/Coax switch.
- INU (RAC 70, RAC 60E/6XE) connection is via a front panel SMA connector. An SMA-to-SMA cable is included with each RFU.
- RSSI access is provided on the front panel as meter test-probe points.
- Power consumption is reduced when Tx power output is lowered. Applies to both ATPC and manual control of Tx power.
- The RFU is 1RU, half-width.
- A front panel tri-color status LED indicates:
  - Red flashing during boot-up
  - Green for normal operation
  - Red when in an alarmed state
  - Orange when in standby mode (standby Tx RFU in a HSB or HSB/SD pairing)
- Includes four SW-controlled, individually alarmed, cooling fans.

#### **RFUv2 (IRU 600v2)**

- The standard (Std) Tx power RFU is powered via its INU cable.
- The high Tx power (HP) RFU is *additionally* powered via a front-panel D-Sub M/F 2W2 connector for wide-mouth +/- 21 to 60 Vdc supply. Both +ve and -ve pins are isolated from ground.
  - The power connector (D-Sub M/F 2W2) and cable is identical to that used for the INU.
  - The integral DC/DC converter provides polarity protection, under/over voltage shutdown, over-current limit, and thermal shutdown.
  - For operation from +24 Vdc supplies, the associated INU/INUe can be fitted with a PCC to convert +24 Vdc to - 48 Vdc. Otherwise a suitable external converter can be used - contact Aviat Networks for details.
- Protected operation for HSB and HSB/SD configurations employs a Tx coaxial switch and an Rx coupler. Switch connection is via a DIN5 connector.
  - The DIN5 connector is located on the right side of the RFUs together with the SMA connector for RF cable connection to the ACU/Coax switch.
- INU (RAC 60E/6XE) connection is via a front panel SMA connector. An SMA-to-SMA cable is included with each RFU.
- RSSI access is provided on the front panel as meter test-probe points.
- The RFU is 1.5 RU, half-width.
- Includes two cooling fans, individually alarmed.

## IRU 600 Compatibility

IRU 600(v1) and IRU 600v2 share a common 3RU chassis. Dimensions and mounting points for V1 and V2 RFUs and ACUs are identical.

IRU 600v3/v4 is housed in a compact 2RU chassis. While the ACU is unique to the V3, the V3 RFUs (Std/HP or EHP) can be used in V1 and V2 chassis using an adapter kit (Part No. 179-530112-001).

The following use guidelines apply:

- V1 and V2 RFUs are compatible sparing partners EXCEPT for HSB configurations where the ACU incorporates a coaxial relay Tx switch (IRU 600v2/v3 ACUs). RFU V1 cannot control the Tx coaxial switch. This means that:
  - V1, V2 RFUs are interchangeable for configurations not using a Tx switch eg. FD, 2+0, SD split Tx, 1+0. Applies to V1 and V2 ACUs.
  - In protected HSB or HSB-ready systems with a V1 ACU (Tx combining), a V2 RFU can spare for a V1.
  - On V2 ACUs configured to use a Tx switch, the V1 RFU cannot spare for a V2 RFU.
  - V2 HP RFUs require installation of a separate power supply connection (+/- 21 to 60 Vdc) to its front panel 2W2 power connector. A power cable is supplied with the RFU.
- V3 RFUs can be installed in an IRU 600(v1) or IRU 600v2 chassis using an adapter kit, which increases V3 RFU unit height to match the mounting points provided for V1 and V2 RFUs.
  - The V3 RFU (with adapter kit installed) can be used in non-protected and protected (HSB or HSB/SD) V1 and V2 chassis.
    - If installed in a V1 chassis *Tx combining* applies for HSB and HSB/SD configurations.
    - If installed in a V2 chassis (with Tx protection switch) *Tx switching* applies for HSB and HSB/SD configurations.
    - If a V3 Std/HP RFU is installed, an HP license must also be installed to enable the high Tx power option on the RFU.
    - If a V3 EHP RFU is installed, a separate power supply connection (+/- 21 to 60 Vdc) to its front panel 2W2 power connector is required. A power cable is supplied with the RFU.
  - V1 or V2 RFUs cannot be installed in a V3 chassis.
- V1 and V2 ACUs are interchangeable. The V3 ACU is not.
  - A V1 ACU can be installed in a V2 chassis, and vice-versa.
  - V1 and V2 ACUs cannot be installed in a V3 chassis. Similarly a V3 ACU cannot be installed in a V1 or V2 chassis.



- All IRUs are over-air compatible. For example, a 1+0 IRU 600(v1) may be linked to a 1+0 IRU 600v2 or IRU 600v3. Similarly, 1+1 HSB IRU 600(v1) may be linked to a 1+1 HSB IRU 600v2 or IRU 600v3. Hybrid configurations are also supported, such as FD linked to SD split Tx.

IRU 600v1 and IRU 600v2 share a common 3 RU chassis. Dimensions and mounting points for V1 and V2 RFUs and ACUs are identical.

IRU 600v3 and IRU 600v4 are housed in a compact 2 RU chassis. While the ACU is unique to each of the V3 and V4, the V3 and V4 RFUs (SP/HP or EHP) can be used in V1 and V2 chassis with existing v1 or v2 ACU using an adapter kit (Part N° 179- 530112-002) for V3 and (Part 179-530508-001) for V4.

The following use guidelines apply:

- V1 and V2 RFUs are compatible sparing partners EXCEPT for HSB configurations where the ACU incorporates a coaxial relay Tx switch (IRU 600v2 ACUs). RFU V1 cannot control the Tx coaxial switch. This means that:
  - V1, V2 RFUs are interchangeable for configurations not using a Tx switch eg. FD, 2+0, SD split Tx, 1+0. Applies to V1 and V2 ACUs.
  - In protected HSB or HSB-ready systems with a V1 ACU (Tx using mute/unmute instead of using an RF Tx switch), a V2 RFU can spare for a V1 by alternatively using mute/unmute instead of attempting to control an RF Tx switch like a v2 RFU normally does.
  - On V2 ACUs configured to use a Tx switch, the V1 RFU cannot spare for a V2 RFU.
  - V2 HP RFUs require installation of a separate power supply connection (+/- 21 to 60 Vdc) to its front panel 2W2 power connector. A power cable is supplied with the RFU.
- V3 and V4 RFUs can be installed in an IRU 600v1 or IRU 600v2 chassis using an adapter kit, which increases the V3 or V4 RFU unit height to match the mounting points provided for V1 and V2 RFUs.
  - The V3 or V4 RFU (with adapter kit installed) can be used in non-protected and protected (HSB or HSB/SD) V1 and V2 chassis.
- If installed in a 3 RMS chassis equipped with a V1 RFU, Tx combining applies for MHSB and MHSB/SD configurations.
- If installed in a 3 RMS chassis equipped with a V2 RFU, (with Tx protection switch) Tx switching applies for MHSB and MHSB/SD configurations.
- If a V3 or V4 SP/HP RFU is installed, an HP license must also be installed to enable the high Tx power option on the RFU.
- If a V3 or V4 EHP RFU is installed, a separate power supply connection (+/- 21 to 60 VDC) to its front panel 2W2 power connector is required. A power cable is supplied with the RFU.
- V1 or V2 RFUs cannot be installed in a V3 chassis.

- V1 and V2 ACUs are interchangeable. The V3 or V4 ACU is not.
  - A V1 ACU can be installed in a V2 chassis, and vice-versa.
  - V1 and V2 ACUs cannot be installed in a V3 or V4 chassis. Similarly, a V3 or V4 ACU cannot be installed in a V1 or V2 chassis.
- All IRUs are over-air compatible when used with a same RAC on both sides of the hop. For example, a 1+0 IRU 600v1 may be linked to a 1+0 IRU 600v2 or IRU 600v3, or IRU 600v4. Similarly, 1+1 HSB IRU 600v1 may be linked to a 1+1 HSB IRU 600v2 or IRU 600v3, or IRU 600v4. Hybrid configurations are also supported, such as FD linked to SD

## 5.8 GHz Unlicensed Band

The RFU for the 5.8 GHz unlicensed band is common to the L6 licensed band for easy transition and sparing (from unlicensed to licensed and vice-versa). Links can be rapidly deployed using 5.8 GHz unlicensed, and subsequently transitioned to L6 on license approval.

- The RFU is a high-power (HP) variant
  - With IRU 600v2 the HP RFU is used.
  - With IRU 600v3 the Std/HP RFU is used (the V3 EHP RFU is not presently available for use on the 5.8 GHz unlicensed band).
    - To operate the V3 Std/HP RFU at high Tx power, an HP license must be installed.
- The 5.8 GHz unlicensed band is designed to support easy and fast deployment. With a suitable antenna, installation can be 'immediate'.
- The common 5.8 GHz / L6 RFU design means subsequent conversion to L6 licensed operation only requires replacement of the ACU.



**NOTE:** 5.8 GHz operation supports fast turn-up for new link requirements. On receipt of a license, operation can be converted to L6 licensed band by replacing the ACU.

Eclipse IDUs and INUs with IRU 600 are compliant with the relevant parts of FCC CFR47, Part 15.407, and Industry Canada RSS-210 Annex 8, on ISM frequency band 5725 to 5850 MHz. International use is not supported; the system does not employ DFS and as such cannot be deployed within Europe or any country where DFS is a regulatory requirement for protection of radars.

### Features and Capabilities:

- ACU filters are tuned 30 MHz wide.
  - Filters are spot tuned (pre-tuned) on 5740.5/5805.5 MHz or 5769.5/5834.5 MHz.
  - With 30 MHz filters just two Tx/Rx pairs can be used to provide full coverage of the band.

- Operation is designed to meet all regulatory requirements associated with 47 CFR Part 15.407. As such, deployment is precluded within 0.5 Mhz of the band edges to comply with band edge emission requirements.
- Bandwidths 5, 10, 20, or 30 MHz.
- Tx and Rx can be paired on different sub-bands (Tx on one 30 MHz sub-band, RX on the other).
- Modulation can be adaptive (QPSK to 256 QAM), or fixed.
- Supports Ethernet and/or NxDS1, NxDS3, or OC3 payloads, with air-link capacities to 189 Mbit/s (30 MHz Ch BW).
- The common 5.8 GHz and L6 RFU supports easy migration from one band to the other (from unlicensed to licensed and vice-versa).
  - RFUs can be retained during migration, but ACU must be replaced (not re-tuned).
- Extensive protection and diversity options.
- Output power (at 5.8 GHz) is limited to 29 dBm at the antenna port to ensure compliance with the FCC 1 Watt rule.
- For Tx power, power control, and system gain figures, see the Eclipse Packet Node ANSI Datasheet.

### **Operational Limitations and Restrictions**

Unlicensed band operation means sharing the air-space with other operators of unlicensed band links. interference is possible.

- IRU 600 5.8 GHz operation is narrow-band (max 30 MHz) high-power; it competes/shares spectrum with other narrow-band links and with spread-spectrum links.
- Performance could deteriorate over time with the introduction of other links in the same geographical area.
- Antennas must be approved (FCC or Industry Canada) for the 5.8 GHz unlicensed band.
  - Eclipse 5.8 GHz is certified for use with a parabolic antenna with a maximum gain of 45.9 dBi or a flat panel antenna with a maximum gain of 28 dBi.

# Eclipse Licensing

---

Eclipse Node, IDU GE3 16x, IDU GE 20x, IDU ES, and IDU 300 20xV2 are subject to capacity licensing. Eclipse Node and IDU GE3 16x are additionally subject to feature licensing on advanced features.

Feature license operation is software release dependent. Ensure you have the relevant software release installed. Refer to [Licensing Requirements and Options on page 1](#).

## INUs:

- Flexible Node-based Licensing applies for Eclipse Node and Packet Node to replace/complement RAC-based licensing.
- Node-based licensing requires SW release 5.0 or later. (SW 5.0 or later must be installed in a Node before installing or upgrading to Node-based licensing).
- Node-based licensing is required for DPP operation and for feature licensing.
- Feature Licensing applies on selected Node features. The licensed features are:
  - **EZF-01:** Layer 1 Link Aggregation (DAC GE). Traffic is between the links on a byte-by-byte basis, based on the capacity of the links. Unlike L2, it is fully effective for just one active session, such as between routers, or where there are only a few concurrent sessions.
  - **EZF-02:** Adaptive Modulation (RAC 70, RAC 60/60E, RAC 6X/6XE). Packet Node adaptive coding and modulation (ACM) dynamically switches between modulation selections. QPSK, 16 QAM, 64 QAM, 256 QAM, 512 QAM, or 1024 QAM (2048 QAM, and 4096 QAM also on the RAC 70/7X). For the RAC 60/6X/60E/6XE, code settings additionally provide two sets of rates for each modulation; one for maximum-throughput, the other for maximum-gain, to provide eight modulation states in total.
  - **EZF-03:** Secure Management (NMS). Applies to Eclipse NMS access over the network, and to local access via the Portal craft tool. It also enables secure management access to Eclipse over an unsecured network, and protects Eclipse configurations from accidental or intentional modification by unauthorized personnel.
  - **EZF-04:** Payload Encryption (RAC 70, RAC 60/60E, 6X/6XE). Encrypts all traffic and management data over the wireless link to prevent eavesdropping.
  - **EZF-05:** Ethernet over TDM (DS3, E1, DS1). Enables mapping of Ethernet data to DS3, E1, or DS1 PDH interfaces using the DAC 3xDS3M or DAC 16x V2/V3. Supports transport of Ethernet data over existing DS3 or Nx E1/DS1 radio or leased-line circuits.
  - **EZF-06:** RADIUS Client. Enables connection validation to a radius server for

- centralized account management.
- **EZF-09:** Synchronous Ethernet. Enables Synchronous Ethernet operation on the DAC GE3.
- **EZF-10:** Ethernet OAM. Enables access to Ethernet Service OAM capabilities.
- **EZF-14 and EZF-1408: TDM Loop Switch**
  - EZF-1408 supports up to 8xE1/DS1 circuits (the max number of drop/insert tributaries supported on the NCM front panel).
  - EZF-14 supports up to 50xE1 or 63xDS1 tributary circuits (the max number of drop/insert tributaries supported on an INU/INUe - requires NCM together with DXR 16xV2 plug-ins).
- **EZF-42:** FIPS 140-2 Secure Operation. Enables secure management of Eclipse in compliance with the Federal Information Processing Standard (FIPS) Publication 140-2. Applies to the INUe only.
- **EZF-48:** FIPS 140-2 + UC-APL Secure Operation. Enables secure management of Eclipse in compliance with the Federal Information Processing Standard (FIPS) Publication 140-2, also includes Unified Capabilities (UC) Approved Products List (APL) compliance. Applies to the INUe only.
- **EZF-43:** Enables IPv6 operation. Includes OSPF IPv6 and RIPNG. Automatically enabled in software 8.1 or later.



**NOTE:** When ODU 300 EP is present in the terminal, IPv4 address is required for software loading.

- **EZF-51 to EZF-56:** ODU 600 high Tx power. Unlocks an additional 3dB of transmit power over standard power. Applies to ODU 600 only, on all modulations, on all bands. It also increases the manual and ATPC transmit power control range by 3dB.
  - EZF-51: ODU 600 High power option 1 x ODU
  - EZF-52: ODU 600 Nodal High power option 2 x ODU
  - EZF-53: ODU 600 Nodal High power option 3 x ODU
  - EZF-54: ODU 600 Nodal High power option 4 x ODU
  - EZF-55: ODU 600 Nodal High power option 5 x ODU
  - EZF-56: ODU 600 Nodal High power option 6 x ODU
- **EZF-61 to EZF-66:** IRU 600v3/v4 high Tx power. Unlocks an additional 3dB of transmit power over standard power. Applies on all modulations, on all IRU 600v3/v4 bands. It also increases the manual and ATPC transmit power control range by 3dB.
  - EZF-61 EZG-61 IRU 600 High power option 1 x RFU
  - EZF-62 EZG-62 IRU 600 Nodal High power option 2 x RFU
  - EZF-63 EZG-63 IRU 600 Nodal High power option 3 x RFU
  - EZF-64 EZG-64 IRU 600 Nodal High power option 4 x RFU

- EZF-65 EZG-65 IRU 600 Nodal High power option 5 x RFU
- EZF-66 EZG-66 IRU 600 Nodal High power option 6 x RFU
- IDU licensing for all IDUs except IDU GE3 16x is unchanged.



**NOTE:** You can upgrade to SW release 5.0 or higher and still continue to use RAC-based licensing but you will not have access to the benefits provided under Node-based licensing (DPP operation and licensed features).

All new Nodes ordered are default installed with the most recent SW release version. From SW release 5.0, can elect to use (order) a Node-based or RAC-based license.

### IDU GE3 16x:

Capacity-based licensing and feature licensing applies on selected features.

#### Capacity Licenses:

- **EZE-10020:** 20 Mbit/s
- **EZE-10050:** 50 Mbit/s
- **EZE-10100:** 100 Mbit/s
- **EZE-10150:** 150 Mbit/s
- **EZE-10200:** 200 Mbit/s
- **EZE-10400:** 400 Mbit/s

#### Feature Licenses:

- **EZF-10002:** Adaptive Modulation
- **EZF-10003:** Secure Management
- **EZF-10006:** RADIUS
- **EZF-10009:** Synchronous Ethernet
- **EZF-10010:** Ethernet OAM
- **EZF-10019:** Enable TDM Ports
- **EZF-10020:** Advanced QoS
- **EZF-10043:** Enables IPv6 operation. Includes OSPF IPv6 and RIPNG. Automatically enabled in software 8.1 or later.



**NOTE:** When ODU 300 EP is present in the terminal, IPv4 address is required for software loading.

- **EZF-10051:** ODU 600 high Tx power option 1 x ODU. Unlocks an additional 3dB of transmit power over standard power. Applies to ODU 600 only, on all modulations, on all bands. It also increases the manual and ATPC transmit power control range by 3dB.
- **EZF-10061:** IRU 600v3/v4 high Tx power option 1 x RFU. Unlocks an additional 3dB of transmit power over standard power. Applies on all modulations, on all IRU

600v3/v4 bands. It also increases the manual and ATPC transmit power control range by 3dB.

# Eclipse Configuration and Management

---

Eclipse is a software-driven product; there are no manual controls. Configuration and management is achieved via Portal and ProVision.

Portal is a PC based configuration and diagnostics tool for Eclipse.

ProVision is the Eclipse network element manager. ProVision also supports other Aviat Networks products, including legacy products.

**Portal** is supported in the Eclipse system software, such that once installed on a PC, it automatically downloads support from the radio as needed to ensure Portal always matches the version of system software supplied, or subsequently downloaded in any radio upgrade.

Portal has the look and feel of a Windows environment with screen-based views and prompts for all configuration and diagnostic attributes.

A Portal PC connects to an INU/INUe/IDU using Ethernet or V.24 options.

For more information see [Introduction to Portal](#).

**ProVision** is the network element manager for all Aviat Networks radios (current and legacy). ProVision also supports partner products, including multiplexors, switches, routers, and power systems.

ProVision is installed on a Windows or Solaris server, typically at a network operating center, and communicates with network elements using standard LAN/WAN IP addressing and routing; each radio has its own unique IP address.

For more information about ProVision, refer to the Aviat Networks ***ProVision User Guide***.

Secure Access from Portal and ProVision is enabled through the Secure Management and RADIUS Client strong security options.



# Eclipse Antennas

---

Antennas for operation on the 5.8GHz unlicensed band are (must be) FCC approved.

- Parabolic antennas for the 5.8 GHz unlicensed band must not exceed a maximum gain of 45.9 dBi.
- Flat panel antennas for the 5.8 GHz unlicensed band must not exceed a maximum gain of 28 dBi.

Antenna mounts are designed for use on industry-standard 115 mm OD (4.5 inch) pipe-mounts.

# Eclipse Power Supply

---

Eclipse is designed to operate from a -48 Vdc power supply (+ve earth) but will operate to specification over a voltage range of -40.5 to -60 Vdc.

A plug-in PCC option for the INU provides a voltage conversion function for locations where the power supply is +24 Vdc. It converts +24 (19 to 36) Vdc to -56 Vdc for connection to the INU -48Vdc input. -56 Vdc represents the typical float voltage for a battery-backed -48 Vdc supply.

The PCC supports:

- Up to a 200W in air-conditioned installations (ambient max 25<sup>0</sup>C / 77<sup>0</sup>F).
- Up to a 150W in non-air-conditioned installations (ambient max 45<sup>0</sup>C / 113<sup>0</sup>F).



**NOTE:** An external +24 Vdc to -48 Vdc converter can be used instead of the PCC. Contact Aviat Networks for details.

The dc power supply must be UL or IEC compliant for SELV (Safety Extra Low Voltage) output (60 Vdc maximum limited).

## Chapter 4. Introduction to Eclipse Installation

---

This section covers installation procedures for Eclipse devices, from unpacking and checking the equipment to completion of the physical installation and antenna alignment.

This section includes:

- [Installation Overview on page 84](#)
- [Before Going On Site on page 85](#)

For information on installing the Portal software to configure Eclipse, see [Installing and Connecting Portal on page 1](#).



**NOTE:** Eclipse has been tested for and meets EMC Directive 89/336/EEC. The equipment was tested using screened cable; if any other type of cable is used, it may violate compliance.



**CAUTION:** Eclipse is a Class A product. In a domestic environment it may cause radio interference: be prepared to resolve this. Eclipse equipment is intended to be used exclusively in telecommunications centers.



**WARNING:** You *must* comply with the relevant health and safety practices when working on or around Eclipse radio equipment. Refer to the section on [Health and Safety on page 25](#).

# Installation Overview

---

This section provides a basic guide, in order, of an Eclipse hardware installation process. Installation can be completed up to antenna alignment without the use of Eclipse Portal, the PC based craft tool. Portal is required to check and configure an Eclipse Node or Terminal.

Hardware installation typically proceeds as follows:

## 1. Pre-Installation

- Unpack equipment - see [Unpacking the Eclipse Equipment on page 86](#)
- Verify system configuration:
- Check basic components
- Check kits and accessories

## 2. Installation

- Antenna - see [See "Installing the Antenna"](#)
- ODU - see [ODU Installation on page 1](#)
- IRU 600 - see [IRU 600 Installation on page 87](#)
- INU / IDU chassis - see [Installing the INU and INUe on page 101](#) or [See "Installing the IDU"](#).
- INU plug-in cards - see [Plug-in Installation Requirements on page 121](#)
- Traffic and NMS cables - as required

## Before Going On Site

This section includes:

- [Installation Tools and Materials on page 85](#)
- [Unpacking the Eclipse Equipment on page 86](#)

## Installation Tools and Materials

Ensure you have the following tools and material before going to site. These are items to be sourced/supplied by the installer.

The items are indicative for standard installations. For non-standard installations additional materials and tools may be required.

**Table 5.** Required Tools and Material

Equipment	Tool/Material	Description
<b>Antenna</b>	As required by the manufacturer	Refer to the manufacturer's data supplied with each antenna for required and recommended installation tools and equipment. (Aviat Networks offers antennas from several suppliers).
<b>Eclipse Radios</b>	Basic electrician's toolkit	The kit must include a crimp lugs, a crimp tool for attaching the lugs to stranded copper cable, a multimeter, and for ODU polarization rotator bolts, a set of metric Allen keys.
	Open-ended spanners	19 mm (3/4 inch) open-ended spanner for attaching the ODU to the mounting collar.
	Torque wrench	Capable of 66 N-m or 50 ft-lb, with a selection of sockets for antenna mount fastening
	Crimp tool(s) for ODU cable connectors	The correct crimp and cut-off tools must be used to avoid damage to the cable outer and to ensure correct crimping of the connectors.
	Hot-air gun	For use on the heat-shrink tubing that may be supplied with some brands of Type N connector.
	Protective grease and zinc-rich paint	For weather-protecting grounding attachment points on towers and grounding bars.
	BNC cable	To access the RSSI voltage at the ODU for antenna alignment. This could be a BNC to banana-plugs cable for connection to a multimeter. Such a cable is available as an optional accessory. Refer to Accessories in the Eclipse Product Ordering Guide.
	4mm <sup>2</sup> (#12) green PVC insulated strand copper wire and grounding lugs	For grounding the indoor unit to the rack/frame
	16 mm <sup>2</sup> (#6) green PVC insulated strand copper wire and grounding lugs	For grounding the rack to the station ground. 16mm is also required for chassis grounding for NEBS compliance.

## Unpacking the Eclipse Equipment

To unpack Eclipse equipment:

1. Open the shipping boxes, carefully remove the equipment and place it on a clean, flat working surface.
2. Ensure all the basic components and accessories for your system have been included in the shipment by comparing the packaging, component part numbers and product descriptions against the packing list, and cross-checking against the installation datapack for the system to be installed.
3. If there has been shipping damage or there are discrepancies between the equipment expected and the equipment received, contact an Aviat Networks Help Desk or your supplier.

## Chapter 5. IRU 600 Installation

---



**NOTE:** Before commissioning an IRU 600 and companion INU, its antenna, waveguide, and waveguide pressurization equipment must be installed according to manufacturer's instructions.

For an overview of IRU 600 features and function, see [IRU 600 on page 67](#).

For information on installing an INU, see [Installing the INU and INUe on page 101](#).

For guidance on installing antennas, waveguide, and pressurization equipment, see the **Best Practices Guide** from Aviat Networks.

### **IRU 600 (v1), IRU 600v2, and IRU 600v3/v4 RFU Sparing Compatibility**

For information on sparing compatibility see [IRU 600 Compatibility on page 72](#).

# IRU 600 Compatibility

---

IRU 600v1 and IRU 600v2 share a common 3 RU chassis. Dimensions and mounting points for V1 and V2 RFUs and ACUs are identical.

IRU 600v3 and IRU 600v4 are housed in a compact 2 RU chassis. While the ACU is unique to each of the V3 and V4, the V3 and V4 RFUs (SP/HP or EHP) can be used in V1 and V2 chassis with existing v1 or v2 ACU using an adapter kit (Part N° 179-530112-002) for V3 and (Part N° 179-530508-001) for V4.

The following use guidelines apply:

- V1 and V2 RFUs are compatible sparing partners EXCEPT for HSB configurations where the ACU incorporates a coaxial relay Tx switch (IRU 600v2 ACUs). RFU V1 cannot control the Tx coaxial switch. This means that:
  - V1, V2 RFUs are interchangeable for configurations not using a Tx switch e.g. FD, 2+0, SD split Tx, 1+0. Applies to V1 and V2 ACUs.
  - In protected HSB or HSB-ready systems with a V1 ACU (Tx using mute/unmute instead of using an RF Tx switch), a V2 RFU can spare for a V1 by alternatively using mute/unmute instead of attempting to control an RF Tx switch like a v2 RFU normally does.
  - On V2 ACUs configured to use a Tx switch, the V1 RFU cannot spare for a V2 RFU.
  - V2 HP RFUs require installation of a separate power supply connection (+/- 21 to 60 Vdc) to its front panel 2W2 power connector. A power cable is supplied with the RFU.
- V3 and V4 RFUs can be installed in an IRU 600v1 or IRU 600v2 chassis using an adapter kit, which increases the V3 or V4 RFU unit height to match the mounting points provided for V1 and V2 RFUs.
  - The V3 or V4 RFU (with adapter kit installed) can be used in non-protected and protected (HSB or HSB/SD) V1 and V2 chassis.
- If installed in a 3 RMS chassis equipped with a V1 RFU, Tx combining applies for MHSB and MHSB/SD configurations.
- If installed in a 3 RMS chassis equipped with a V2 RFU, (with Tx protection switch)
- Tx switching applies for MHSB and MHSB/SD configurations.
- If a V3 or V4 SP/HP RFU is installed, an HP license must also be installed to enable the high Tx power option on the RFU.
- If a V3 or V4 EHP RFU is installed, a separate power supply connection (+/- 21 to 60 VDC) to its front panel 2W2 power connector is required. A power cable is supplied with the RFU.



- V1 or V2 RFUs cannot be installed in a V3 chassis.
- V1 and V2 ACUs are interchangeable. The V3 or V4 ACU is not.
  - A V1 ACU can be installed in a V2 chassis, and vice-versa.
  - V1 and V2 ACUs cannot be installed in a V3 or V4 chassis. Similarly, a V3 or V4 ACU cannot be installed in a V1 or V2 chassis.
- All IRUs are over-air compatible when used with a same RAC on both sides of the hop.
  - For example, a 1+0 IRU 600v1 may be linked to a 1+0 IRU 600v2 or IRU 600v3, or IRU 600v4. Similarly, 1+1 HSB IRU 600v1 may be linked to a 1+1 HSB IRU 600v2 or IRU 600v3, or IRU 600v4. Hybrid configurations are also supported, such as FD linked to SD.

**Table 6.** RAC Compatibility Over-Air Links Guidelines and Examples:

IRU 600	RAC	Link Direction	IRU 600	RAC
V3 or V4	60/6X	Same	V4 or V3	60/6X
V4 or V3	70/7X	Same	V3 or V4	70/7X
V3 or V4	60/6X	Independent	V4 or V3	70/7X
V4 or V3	70/7X	Independent	V3 or V4	60/6X

# IRU 600 Installation Procedure

---

This procedure applies to IRU 600v4, IRU 600v3, IRU 600v2, and IRU 600(v1).

- Unless otherwise stated, reference to IRU 600 refers to all IRU 600 variants.
- Unless otherwise stated, reference to a V2 RFU refers to standard power (Std) and high-power (HP) variants.
- Unless otherwise stated, reference to a V3/V4 RFU refers to standard power (Std), high-power (HP), and extra high-power (EHP) variants.

The IRU 600v3/v4 Std/HP RFU is SW configured for standard or high-power. The HP option requires installation of HP feature license EZF-61 to 66, or EZG-61 to 66. See [Node Feature Licensing on page 1](#).

See:

- [Chassis Installation on page 90](#)
- [Chassis Grounding on page 93](#)
- [Waveguide Installation on page 94](#)
- [Waveguide Connection to ACU on page 94](#)
- [Power Supply Connection on page 95](#)
- [Insertion Loss Labels on page 97](#)
- [IRU 600 Installation on page 87](#)
- [Expansion Port Use on page 97](#)
- [FAN Module on page 97](#)
- [IRU 600 Installation on page 87](#)
- [Chassis Adapter Kit for IRU 600v3 and IRU 600v4 RFUs on page 98](#)  
[Chassis Adapter Kit for IRU 600v3 and IRU 600v4 RFUs on page 98](#)  
[Chassis Adapter Kit for IRU 600v3 and IRU 600v4 RFUs on page 98](#)

## Chassis Installation

1. Fit the rack mounting brackets onto the chassis.
  - Brackets can be mounted in either a forward mount or a flush mount position.
  - Brackets can be mounted such that the grounding stud is to the left or right side.
2. Install the chassis. If installing multiple chassis:
  - For IRU 600(v1) and IRU 600v2 install with a 3RU space between the chassis to permit installation of an expansion or extension kit. This space can be used to

install an INU/INUE/IDU GE3 16x.

- For IRU 600v3/v4 no chassis spacing is required, but a 1RU space should be retained above the top and below the bottom of the chassis stack to ease hand access to RFU - ACU cable installation.

3. Locate and secure RFU(s) and ACU in the IRU 600 chassis.

- For IRU 600v3/v4 the chassis-mounted post fitted to secure the right side of the RFU / left side of the ACU front cover is removable.
- This is to assist connection/dis-connection of the RFU SMA connectors, and the DIN5 connector on 1+1 configurations.

**CAUTION:** When re-fitting the IRU 600v3/v4 removable post do not over-tighten. Thumb-tighten only to avoid thread-stripping.

**Figure 35.** IRU 600v3 Removable Post

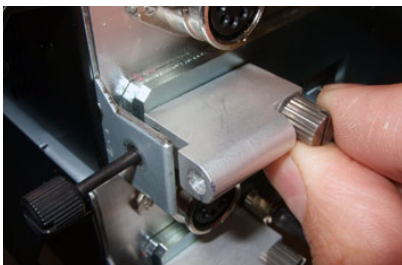

4. Connect the RFU(s) to the ACU using the supplied RF cables. Refer to the cabling diagram on the rear side of the ACU front panel. The lower RFU is A-side, the top B-side. A-side is the default online RFU in a 1+1 protected pairing.

**Figure 36.** Example Cabling Diagram on Rear of ACU Front Panel

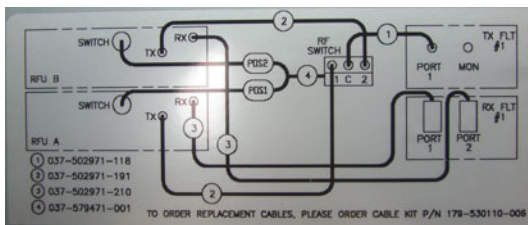

- For IRU 600v2 and IRU 600v3/v4 ACUs fitted with a Tx coaxial switch, fit the RFU-to-switch cable assembly.
  - For IRU 600v3/v4 the fixing post in front of the RFU connectors can be removed to aid connector access. See step 3 above.
  - Ensure cables connect to the correct RFU. Refer to the cabling diagram on the rear side of the ACU front cover.
  - Ensure DIN5 RFU cable connectors are correctly inserted and locked using the connector locking ring - turn the ring clockwise until clicked into its locked position.
  - Ensure the switch connector is held secure using its screw fasteners.

- The Tx switch cable must remain securely connected at all times. Incorrect communication between the RFU and Tx switch may result in mismatched A-side and B-side operation and loss of standby.

 **CAUTION:** Check installation of DIN5 RFU cable connectors. The lock ring should home with an audible click.

 **NOTE:** Multiple voltage piles are used to energize the Tx switch relay.

- Connect the RFU(s) to the INU/INUe RAC 70, RAC 60/60E or RAC 6X/6XE card(s) using the supplied IF cable(s). The minimum bend radius of the IF cable is 25 mm.
- For the IRU 600v2 HP RFU and for the IRU 600v3/v4 EHP RFU, which are additionally powered using a separate DC input on their front panel, refer to [Power Supply Connection on page 95](#) for DC power installation.

**Figure 37.** IRU 600 and INU



**Figure 38.** IRU 600v2 Tx Switch and RFUv2 Connections



**Figure 39.** IRU 600v3/v4 Tx Switch and RFUv3 Connections

**CAUTION:** Ambient temperatures must not exceed 55<sup>0</sup>C (131<sup>0</sup>F). If installed in a rack cabinet, it is the ambient within the cabinet.

## Chassis Grounding

The chassis grounding stud accommodates ground cables up to 16 mm<sup>2</sup> (AWG 6). The stud also provides jack plug connection for a wrist strap.

- Ground the IRU 600 from the grounding stud to the rack/frame ground bar using 4 mm<sup>2</sup> (AWG 12) green PVC insulated stranded copper wire with a suitably sized crimp lug at the ground bar end (supplied by the installer). For NEBS grounding compliance, see below.
- If the equipment rack/frame requires grounding, use 16 mm<sup>2</sup> (AWG 6) wire from its ground bar to the station ground.

## NEBS Compliant Grounding

These grounding requirements apply for a NEBS compliant installation.

- Ground the IRU 600 from the grounding stud to the rack/frame ground bar using 16 mm<sup>2</sup> (AWG 6) green PVC insulated stranded copper ground wire (not 4 mm<sup>2</sup>) together with a star washer under the grounding screw at the ground-bar end. Torque the grounding post screw to 1.2-1.5 Nm (10-13 in-lbs).
- Coat all bare conductors with an appropriate antioxidant compound before crimp connectors are fitted.
- Ensure all unplated connectors, braided strap, and bus bars are brought to a bright finish and then coated with an antioxidant before they are connected. This does not apply to tinned, solder-plated, or silver-plated connectors and other plated connection surfaces – but all must be clean and free of contaminants.

- Where metallic raceway fittings are installed ensure all fittings are tightened to provide a permanent low-impedance path.

## Safety Requirements for Equipment Grounding

- Do not assume that an existing rack or mounting frame is correctly grounded. Always check the integrity of the ground connections, which must include a check through to the master ground for the station, which should be located at the point of cable entry to the equipment building. Ground wires must provide a direct, low impedance path to the master ground bar.
- Do not connect other equipment to the same grounding cable as the INU. Each item of equipment in a rack must be separately grounded to the rack ground bar.
- The INU / IRU 600 must be located in the same immediate area (adjacent racks/cabinets) as all other equipment with a (ground) connection to a common DC supply source.
- All intra-building signal cabling must be shielded, and both ends of each shield must be grounded.
- There must be no switching or disconnecting devices in the grounded circuit conductor between the DC source and the point of connection of the grounding electrode conductor.

## Waveguide Installation

For instructions on waveguide installation and associated pressurization and grounding requirements, refer to the relevant documentation from the waveguide supplier. General guidance can be found in Aviat Networks **Best Practices Guide**.

## Waveguide Connection to ACU

Connect ACU antenna port(s) to waveguide(s) using flexible waveguide.

- Information on required waveguide flanges and recommended waveguide types are listed in the following table.
- Remove and discard any protective flange/port covers before installation.

**Figure 40.** ACU and Waveguide Connection

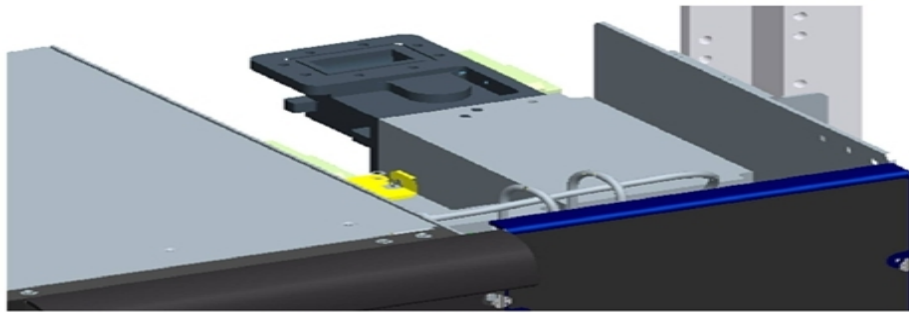

**Table 7.** ACU Flange Data

Freq, GHz	Flange Type	Holes	Screw Length	Waveguide
5.8/6	CPR 137 G	8 x #10-32 tapped holes	1/2"	WR 137

ACU Flange Type		ACU Frequency					
		5.8/6GHz (IRUv1/v2)	7/8GHz (IRUv1/v2)	10/11GHz (IRUv1/v2)	4GHz	5.8/6GHz (IRUv3)	11GHz (IRUv3)
ACU Antenna Port	Flange Type	CPR137-G	CPR112-G	CPR90-G	CMR187	CMR137	UG39
	Hole size	8X #10-32	8X #8-32	8X #8-32	8X #6-32	8X #6-32	4X #8-32
	Screw Length	1/2" *	7/16" *	7/16" *	7/16"	7/16"	7/16"
ACU Expansion Port	Flange Type	CMR137	CMR112	UG39	CMR187	CMR137	UG39
	Hole size	8X #6-32	8X #6-32	4X #8-32	8X #6-32	8X #6-32	4X #8-32
	Screw Length	7/16"	7/16"	7/16"	7/16"	7/16"	7/16"
Waveguide Body Size		WR137	WR112	WR90	WR187	WR137	WR90

\* The screw length assumes a flex twist mating flange thickness of 1/4".

## Power Supply Connection

**NOTE:** The DC power supply must be SELV compliant (maximum limited 60 Vdc).

For IRU 600 power consumption figures refer to [INU Power Supply on page 103](#).

### Power Supply Requirements

RFUs not fitted with a front-panel D-Sub M/F 2W2 power connector are powered via the IF cable from their associated INU/INUe. These are:

- Standard power IRU 600(v1) and IRU 600v2 RFUs
- Standard/High power IRU 600v3/v4 RFUs

RFUs fitted with a front-panel D-Sub M/F 2W2 power connector are *additionally* powered by a front panel connector. These are:

- High power IRU 600(v1) and IRU 600v2 RFUs
- Extra high-power (EHP) IRU 600v3/v4 RFUs
- The power connector and cable are identical to that used for the INU/INUe.

### **-48 Vdc and +24 Vdc Operation**

The associated INU/INUe requires a -48Vdc power input. For operation from a +24 Vdc power supply a +24 to -48 Vdc converter is required.

- The plug-in PCC (Power Converter Card) can be installed to convert +24 Vdc to -48 Vdc for connection to the -48 Vdc connector on the NCC. Two PCCs are required if an NPC is also installed.
  - A PCC supports power consumption for the INU/INUe plus a maximum of three V1 or V2 RFUs, or a maximum of two V3/V4 RFUs. See [PCC +24 Vdc Operation on page 1](#)
- Otherwise a suitable external converter can be used - contact Aviat Networks for details.

RFUs fitted with the front-panel D-Sub M/F 2W2 power connector support a wide-mouth +/- 21 to 60 Vdc connection.

- Both +ve and -ve pins are isolated from ground. They can be powered from +24 Vdc or -48 Vdc supplies.
- The integral DC/DC converter provides polarity protection, under/over voltage shutdown, over-current limit, and thermal shutdown. There are no serviceable fuses.
- Run the supplied power cable through to a dedicated circuit breaker on the rack power connect panel.
  - For a -48 Vdc supply, connect the blue wire to -48 Vdc (live), and the black wire to ground/+ve. The circuit breaker should have rating of 3 A.
  - For a +24 Vdc supply, connect the blue wire to +24 Vdc (live), and the black wire to ground/-ve. The circuit breaker should have rating of 5 A.
  - For NEBS compliance the battery return connection is to be treated as an isolated DC return (DC-I), as defined in GR-1089-CORE.



**CAUTION:** Use the RFU circuit breaker as the power connect/disconnect device - do not use the front-panel 2W2 DC connector for live power connect/disconnect.

### **IRU 600(v1) and IRU 600v2**

Standard power RFUs are powered over the IF cable from its INU/INUe.

High power RFUs (HP) are additionally powered using a separate DC input on their front panel.

### **IRU 600v3**

- The Std/HP RFU is powered over the IF cable from its INU/INUe.
  - The RFU is SW configured for standard or high-power. High power operation



requires installation of a feature license (EZF-61 to 66, or EZG-61 to 66).

- A feature license is not required for the EHP RFU.

## Insertion Loss Labels

Labels on the ACU provide factory-measured insertion loss data. These list the loss for each filter and circulator, and the total loss through the ACU (filters, circulators, cables, plus any protection components, such as Tx switch and couplers). Total (combined) loss figures are entered into Portal to enable computation of Tx power and RSL figures at the ACU antenna waveguide port(s) based on the RFU measured values of Tx power and RSL.

For IRU 600v2 and IRU 600v3/v4 an additional label shows the insertion loss of the Tx monitoring port. The value must be considered when measuring output power with a power meter.

## Expansion Port Use

The expansion port allows system expansion through the addition of co-located IRU 600 radios, or external radio equipment.

When multiple carriers are deployed on a common branching network (same antenna), the selection and installation of branching network components must be such that threshold degradation caused by intermodulation products is avoided.

- While the IRU 600 ACUs are specified to avoid placing undue constraints on frequency planning for multiple carrier systems, the following conditional requirements are intended to provide guidelines on the selection and installation of branching frequencies and components.
  - The intermodulation frequency products that result from combining two or more transmitter frequencies on a common antenna feeder should be 48 MHz or more above or below each of the receiver frequencies present on the same antenna feeder.
  - Systems employing carrier frequencies with potential to cause intermodulation products within 48 MHz of any of the receiver frequencies present on the same antenna branching network (feeder) must be designed and installed to mitigate the effects of such intermodulation products.

## FAN Module

The fan units in an RFU are removable for service/replacement. Fan module replacement is non-traffic affecting.



**CAUTION:** *Fan module hazard - keep away from moving fan blades.*

**CAUTION:** Handle the FAN module with care. Do not physically shock the module or touch the fan impeller blades. Doing so can move the impeller off-center and cause premature fan failure.

- For IRU 600(v1) and IRU 600v2 a fan cover is removed to expose the two fans. Removal and replacement is per-fan.
- For the IRU 600v3 the four fans are located on a removable/replaceable front-cover fan tray.
  - To remove, unscrew the fan tray fasteners, ease outwards, and carefully disconnect the rear cable connector. Fan replacement is per-tray.
  - When replacing the fan tray ensure the supply cable is routed so it is not pinched when the tray is fastened, and that during operation it cannot come into contact with a fan.
- Fan operation is monitored. Each fan has a matching alarm.
- For IRU 600(v1) and IRU 600v2 both fans are operated at a fixed speed.
- IRU 600v3 fan speed is temperature-dependent.

**NOTE:** If one fan needs to be replaced, replace all fans.

**Figure 41.** IRU 600v3 Fan Tray Removal



## Chassis Adapter Kit for IRU 600v3 and IRU 600v4 RFUs

An adaptor kit (part No. 179-530112-002) is available to enable installation of an IRU 600v3 RFU into an IRU 600v2 or IRU 600v1 chassis.

Adaptor kits to enable installation into an IRU 600v2 or IRU 600v1 chassis are as follows:

- (Part No. 179-530112-002) is available to enable installation for an IRU 600v3 RFU, and
- (Part No. 179-530508-001) for an IRU 600v4 RFU.

The kit is used where an existing V2 or V1 chassis is to be upgraded to V3/V4 capabilities – the existing V2 or V1 RFU is replaced by a V3/V4 Std/HP RFU, or EHP RFU.

One kit is required per IRU 600v3/v4 RFU.

 **NOTE:** For the IRU 600v3 or v4 to be recognized the installed Eclipse SW must be 07.03.56, or later compatible release.

The kit, comprises:

- A riser plate that properly locates the physically smaller IRU 600v3/v4 RFU within the V2 or V1 chassis.
- Extension plate for the V3 or V4 Fan Tray to provide a neat and integrated appearance in its V2 or V1 host chassis. The extension plate is designed for use with all V3 or V4 Fan Tray types.
- Various screws and an overlay to mask an unused screw hole.
- Installation instructions.

**NOTE:**

- Where the V3 or V4 Std/HP RFU is installed an HP feature license (EZF-61 to 66, or EZG-61 to 66) must be installed to enable the HP option.
- Where the V3 or V4 EHP RFU is installed a feature license is not required – the EHP capability is inclusive.
- Where a V3 or V4 RFU (or V2) RFU is used in a system with a V1 ACU, the 'Mute Offline Tx Power' tab on the IRU 600v3/v4 (or IRU 600v2) plug-ins RAC/RFU screen may be retained until Break/Create protection is toggled. In the Protection screen, break protection and click Send, followed by create protection and Send, after which the 'Mute Offline Tx Power' tab will be removed to reflect that it is operating in a V1 environment.

For information on V4, V3, V2, V1 compatibility see [IRU 600 Compatibility on page 72](#).

**Procedure**

- Install the adapter kit on the V3 or V4 RFU according to the adapter kit instruction sheet.
- If the V3 or V4 RFU is Std/HP and the HP capability is required, install the relevant HP feature license. (A feature license is not required for the EHP RFU).
- Install the V3 or V4 RFU in the IRU 600 V1 or V2 chassis according to the instruction sheet.
- For the V3 or V4 EHP RFU install the supplied DC power cable. Ensure it is terminated onto a correctly sized circuit breaker. See [Power Supply Connection on page 95](#).
- Configure the IRU 600 with V3 or V4 RFU according to the instructions provided in the Portal Chapter of this manual. See [Configuration Procedures for RAC 70/7X, RAC 60/6X and RAC 60E/6XE on page 1](#).

## Next Steps

- INU/INUe installation. Refer to [Installing the INU and INUe on page 101](#).

## Chapter 6. Installing the INU and INUE

---

The INU and the INUE are the indoor units for the Eclipse Node.

This chapter includes:

- [INU/INUE Description on page 102](#)
- [Compact Flash Card on page 1](#)
- [INU/INUE Installation Requirements on page 115](#)
- [Installation on page 118](#)
- [Plug-in Slot Configuration](#)
- [Plug-in Installation Requirements on page 121](#)

For a description of the plug-ins, refer to the *Eclipse Platform Product Description*.

For information on user-interface connector and cable data, refer to [INU/INUE and IDU Connector and Cable Data on page 1](#).



**CAUTION:** With the increase in the capabilities and complexity of some new plug-in modules, such as RAC 60E, RAC 6XE, DAC GE3, Compact Flash cards with increased capacity are required. See [Compact Flash Card on page 1](#).



**CAUTION:** Do not turn power off within 10 minutes of initial INU/INUE turn-on, or initial turn-on after a new compact flash card is installed.



**CAUTION:** There must be a minimum of 50 mm (2") of side spacing from the INU/INUE to any rack panels, cable bundles or similar, and 50 mm (2") of space to the front and back of the RF section to ensure proper ventilation.

## INU/INUe Description

The INU/INUe is a rack-mounted unit that pairs with one or more ODUs or one or more IRU 600s to make an Eclipse Node.

An INU/INUe comprises a chassis (IDC/IDCe) and plug-ins.

The IDC/IDCe has dedicated slots for the NCC and FAN plug-ins, and either four slots (IDC) or ten slots (IDCe) available for optional RAC, DAC, AUX and NPC plug-ins.

Refer to:

- IDC V1 and IDC V2 and INU Front Panel Layout in this section
- [FAN Air Filter Option on page 113](#)
- [Power Line Filter Option on page 114](#)
- [Plug-in Slot Configuration on page 1](#)

## INU Front Panel Layout

This figure is an example of an INU front panel, with one DAC x16, two RAC 30s, and a blanking panel over the unused slot. For a full description of all plug-ins and their front panel layouts, refer to the *Eclipse System Description*.

**Figure 42.** Typical INU Front Panel Layout

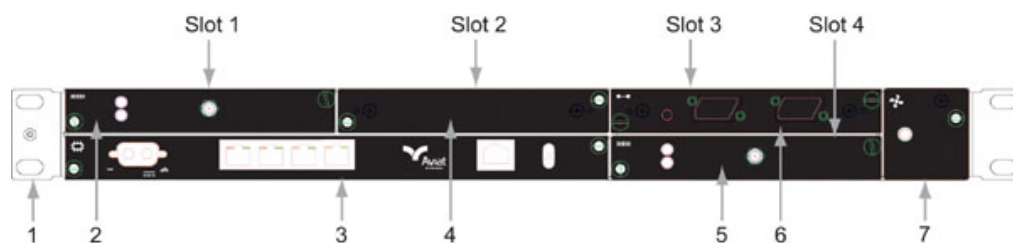

No	Item/Label	Description
1	Rack Ear and grounding stud	Rack attachment bracket for the IDC. One ear has a combined ESD and IDC grounding stud. The ears can be fitted either side, which provide flush-with-rack-front mounting.
2	RAC 30	RAC 30 fitted in slot 1
3	NCC	Mandatory Node Control Card (dedicated slot)
4	Blank Panel	Blanking panel fitted to slot 2
5	RAC 30	RAC 30 fitted in slot 4

No	Item/Label	Description
6	DAC 16x	16xE1/DS1 DAC fitted in slot 3
7	FAN	Mandatory fan plug-in (dedicated slot)

## INU Power Supply

INUs require a -48 Vdc power supply (+ve earth) but will operate to specification over a voltage range of -40.5 to -60 Vdc.

The return (+ve) pin on the NCC and NPC power supply connectors is clamped to chassis ground via polarity-protecting power FETs.

- NCC and NPC power inputs are reverse polarity protected (the input fuse will not blow if polarity is reversed).

For NEBS compliance the battery return connection is to be treated as a common DC return (DC-C), as defined in GR-1089-CORE.

Where operation from a +24 Vdc PSU is required, the plug-in PCC option provides voltage conversion from +24 (19 to 36) Vdc to -56 Vdc for connection to the NCC -48Vdc input. -56 Vdc represents a typical (maximum) float voltage for a battery-backed -48 Vdc supply. Otherwise an external +24 to -48 Vdc converter can be used - contact Aviat Networks for details.

The dc power supply must be UL or IEC compliant for SELV (Safety Extra Low Voltage) output (60 Vdc maximum limited).

Voltage changes due to the regulation of the power supply must not exceed a change-rate (linear variation slope) of 7 V/ms, as specified in TSI EN 300 132-2 V2.4.6. Applies over variations between -40.5 Vdc to -57 Vdc.

## Power Consumption and INU Load Maximums

Total power consumed is dependent on the number and type of plug-in cards, the number and type of ODU(s) or IRU 600, plus for the ODUs, the frequency band.

INU loading maximums, the number and type of RACs and DACs that can be installed in an INU, are determined by the load capacity and temperature limits of the DC converter in the NCC and NPC, which supply various DC rails to the plug-in cards. Load maximums are also dependent on the SW release in use, and the version of NCC and NPC installed. For more information see Node Card Maximums below.

- ODUs, IRU 600s and FANs are not powered via the NCC converter, meaning the ODU and IRU 600 type does not impact INU link loading. Their DC supply is taken from the -48 Vdc power supply input connector.
- However, if a PCC is installed for +24 Vdc operation, the INU cards *and* associated ODUs or IRU 600s are supplied from the PCC, meaning PCC power limits are

determined by the INU cards *and* by the number and type of ODUs or IRU 600s fitted.

- A PCC should always be installed to receive maximum FAN cooling. This means it should be installed in the immediate FAN-side slots in an INU/INUE.



**NOTE:** A suitable external +24 Vdc to -48 Vdc converter can be used instead of the PCC. Contact Aviat Networks for details.

## Power Consumption

Power consumption figures are for a -48 Vdc supply voltage at normal room ambients.

### Plug-in Cards

The table below lists nominal power consumption figures for Eclipse plug-ins.

- Use these together with the ODU or IRU600 consumption figures in the following tables to determine total nodal power consumption.
- When operated with an ODU, cable power dissipation should be considered.

**Table 8.** Typical Plug-in Power Consumptions

Item	Consumption W
RAC30v3, RAC 30A	8
RAC40	10
RAC 4X	15
RAC 3x	11
RAC 60/60E	12
RAC 6X/6XE	17
RAC 70	13
DAC ES, 16x, 16xV2, 4x, 3xE3/DS3, 3xE3/DS3M	2.5
DAC GE, 155o, 2x155o, 2x155e, 155oM, 155eM	4
DAC GE3	13
NCM	10
NCC	11
NPC	8
AUX	1
FAN 1RU*	2
FAN 2RU*	2

\* FANs are not powered via the NCC/NPC converter.



## IRU 600(v1) and IRU 600v2

The table below lists nominal figures.

- For a standard power RFU, DC power is provided from its INU/INUE via its RAC - RFU cable (in the same way as an ODU).
- For a high-power RFU, power is supplied via its RAC cable *and* additionally by a front-mounted DC connector to an external DC power source. High power is enabled through feature licensing. See [Licensing on page 1](#).

**Table 9.** Typical IRU 600(v1) and IRU 600v2 Power Consumption

Configuration	Band	Power Sourced from INU	Power Sourced from External DC Connector	Total DC Power
1+0 Configurations Std Power – Normal Operation	L6/U6	52W	N/A	52W
1+0 Configurations Std Power –All Tx Muted	L6/U6	30W	N/A	30W
1+0 Configurations High-Power – Normal Operation	5.8/L6/U6 /7/8/10/11	52W	38W	90W
	4GHz	N/A	80W	80W
1+0 Configurations High-Power – All Tx Muted	5.8/L6/U6 /7/8/10/11	30W	4W	34W
	4GHz	N/A	25W	25W
1+1 Configurations Std Power – Normal Operation	L6/U6	82W	N/A	82W
1+1 Configurations Std Power – All Tx Muted	L6/U6	60W	N/A	60W
1+1 Configurations High-Power – Normal Operation	5.8/L6/U6 /7/8/10/11	82W	42W	124W
	4GHz	N/A	105W	105W
1+1 Configurations High-Power – All Tx Muted	5.8/L6/U6 /7/8/10/11	60W	8W	68W
	4GHz	N/A	50W	50W
1+1 Configurations employing FD Std Power – Normal Operation	L6/U6	104W	N/A	104W
1+1 Configurations employing FD Std Power – All Tx Muted	L6/U6	60W	N/A	60W
1+1 Configurations employing FD High-Power – Normal Operation	5.8/L6/U6 /7/8/10/11	104W	76W	180W
	4GHz	N/A	160W	160W

Configuration	Band	Power Sourced from INU	Power Sourced from External DC Connector	Total DC Power
566651+1 Configurations employing FD High-Power – All Tx Muted	5.8/L6/U6 /7/8/10/11	60W	8W	68W
	4GHz	N/A	50W	50W
1+1 Configurations Std Power – MHSB (IRU 600v2 Only)	L6/U6	104W	N/A	104W
1+1 Configurations High-Power – MHSB (IRU600v2 Only)	5.8/L6/U6 /7/8/10/11	104W	76W	180W
	4GHz	N/A	160W	160W
1+1 Configurations Std Power – MHSB (IRU 600v2 Only)	L6/U6	82W (avg)	N/A	82W (avg)
		104W (peak)		104W (peak)
1+1 Configurations High-Power – MHSB (IRU600v2 Only)	5.8/L6/U6 /7/8/10/11	82W (avg)	42W (avg)	124W (avg)
		104W (peak)	76W (peak)	180W (peak)
	4GHz	N/A	105W (avg) 160W (peak)	105W (avg) 160W (peak)

### IRU 600v3

The table below lists typical and maximum power consumption figures at maximum Tx power settings.

- A common RFU is used for standard (SP) and high-power (HP) modes. High power is enabled through feature license. See [Licensing on page 1](#).
  - For both standard power and high-power operation DC power to the RFU(s) is provided from its INU/INUe via the RAC - RFU cable.
- The EHP RFU power is supplied via its INU/INUe RAC cable *and* additionally by a front-mounted DC connector to an external DC power source.

**Table 10.** Typical and Maximum IRU 600v3 Power Consumption

Configuration	Typical INU/INUe Source Pwr	Max INU/INUe Source Pwr	Typical External DC Source Pwr	Max External DC Source Pwr
1+0 Configurations IRU 600SPv3 – Normal Operation	58W	63W	N/A	N/A
1+0 Configurations IRU 600SPv3 – All TX Muted	42.5W	46.5W	N/A	N/A

1+0 Configurations IRU 600HPv3 – Normal Operation	63W	68W	N/A	N/A
1+0 Configurations IRU 600HPv3 – All TX Muted	42.5W	46.5W	N/A	N/A
1+0 Configurations IRU 600EHPv3 L6 – Normal Operation	58W	63W	56W	60W
1+0 Configurations IRU 600EHPv3 U6 – Normal Operation	61.5W	65.5W	60W	63.5W
1+0 Configurations IRU 600EHPv3 11GHz – Normal Operation	58W	63W	43W	46W
1+0 Configurations IRU 600EHPv3 L6/U6/11– All TX Muted	42.5W	46.5W	3.5W	4W
1+1 Configurations IRU 600SPv3 – HSB Mode	100.5W	109.5W	N/A	N/A
1+1 Configurations IRU 600SPv3 – All TX Muted	85W	93W	N/A	N/A
1+1 Configurations IRU 600HPv3 – HSB Mode	105.5W	114.5W	N/A	N/A
1+1 Configurations IRU 600HPv3 – All TX Muted	85W	93W	N/A	N/A
1+1 Configurations IRU 600EHPv3 – L6 - HSB Mode	100.5W	109.5W	59.5W	64W
1+1 Configurations IRU 600EHPv3 – U6 - HSB Mode	104W	112W	63.5W	67.5W
1+1 Configurations IRU 600EHPv3 – 11 - HSB Mode	104W	112W	43W	46W
1+1 Configurations IRU 600EHPv3 – L6 - All TX Muted	85W	93W	7W	8W
1+1 Configurations IRU 600EHPv3 – U6 - All TX Muted	85W	93W	7W	8W
1+1 Configurations IRU 600EHPv3 – 11 - All TX Muted	85W	93W	7W	8W
1+1 FD Configurations IRU 600SPv3 – Normal Operation	116W	126W	N/A	N/A
1+1 FD Configurations IRU 600SPv3 – All TX Muted	85W	93W	N/A	N/A
1+1 FD Configurations IRU 600HPv3 – Normal Operation	126W	136W	N/A	N/A
1+1 FD Configurations IRU 600HPv3 – All TX Muted	85W	93W	N/A	N/A
1+1 FD Configurations IRU 600EHPv3 – L6 - Normal Operation	116W	126W	112W	120W
1+1 FD Configurations IRU 600EHPv3 – U6 - Normal Operation	123W	131W	120W	127W
1+1 FD Configurations IRU 600EHPv3 – 11GHz - Normal Operation	116W	126W	86W	92W
1+1 FD Configurations IRU 600EHPv3 L6/U6/11– All TX Muted	85W	93W	7W	8W
1+1 Configurations IRU 600SPv3 – MHSB Mode	116W	126W	N/A	N/A
1+1 Configurations IRU 600HPv3 – MHSB Mode	126W	136W	N/A	N/A
1+1 Configurations IRU 600EHPv3 – L6-MHSB Mode	116W	126W	112W	120W
1+1 Configurations IRU 600EHPv3 – U6-MHSB Mode	123W	131W	120W	127W
1+1 Configurations IRU 600EHPv3 – 11-MHSB Mode	116W	126W	86W	92W
1+1 Configurations IRU 600SPv3 – P-MHSB Mode	100.5W Avg	109.5W Avg	N/A	N/A
	116W Peak	126W Peak		

1+1 Configurations IRU 600HPv3 – P-MHSB Mode	105.5W Avg 126W Peak	114.5W Avg 136W Peak	N/A	N/A
1+1 Configurations IRU 600EHPv3 –L6 - P-MHSB Mode	100.5W Avg 116W Peak	109.5W Avg 126W Peak	59.5W Avg 112W Peak	64W Avg 120W Peak
1+1 Configurations IRU 600EHPv3 –U6 - P-MHSB Mode	104W Avg 123W Peak	112W Avg 131W Peak	63.5W Avg 120W Peak	67.5W Avg 127W Peak
1+1 Configurations IRU 600EHPv3 –11 - P-MHSB Mode	100.5W Avg 116W Peak	109.5W Avg 126W Peak	46.5W Avg 86W Peak	50W Avg 92W Peak

### IRU 600v4

The table below lists maximum power consumption figures at maximum Tx power settings.

- A common RFU is used for standard (SP) and high-power (HP) modes. High power is enabled through feature license.
- For both SP and HP operation, DC power to the RFU(s) is provided from its INU/INUe via the RAC - RFU cable.
- The EHP RFU power is supplied via its INU/INUe RAC cable and additionally by a front-mounted DC connector to an external DC power source.

**Table 11.** Maximum Power Consumption (W) - IRU 600v4 with RAC 70

	Maximum Output Power (dBm)			
SP/HP Configuration, 1+0 unit (Typical)	31.5	27.0	22.0	Tx Muted
11 GHz	64.3	47.5	39.8	23



#### NOTE:

- For an EHP Configuration, 1+0 unit, the Maximum Power Consumption is 100 W.
- TX power values at RFM port, under ambient temperature of +30 °C.
- TX power level shown is referenced at the 1+0 ACU antenna port.
- The power consumption is channel bandwidth independent and is the same for any given TX power.
- The delta between TX output power at 1+0 ACU antenna port and the RFM port is the 1+0 ACU loss. For 11 GHz, ACU loss is 2.0 dB.

## Node Card Maximums

From SW release 5.04 improvements in the cooling fan operating logic allow higher card loadings coupled with maximum ambients to 55°C (131°F), or 45°C (113°F).

- From software release 5.04 fan logic improvements allow higher INUe loading when an NPC is installed.
- An NPC must be fitted in an INUe where specified below. The NPC provides power

supply load sharing with the NCC, allowing the overall loading to be increased. Should the NPC fail, airflow from the 2RU FAN is increased to compensate.

- Extended FAN failure/impairment detection is included. For example, an alarm will be raised on a reduction in fan speed (RPM), such as can occur as a result of bearing wear/friction.
- The loading maximums are designed to ensure systems will continue to operate correctly in the event of failure of either the NCC or NPC.

From November 2012 new card maximums (loading rules) apply with the availability of updated high-output NCC and NPC cards. These new cards have part numbers of EXN-003 and EXS-002 respectively.

- The updated NCC and NPC cards are required where node loading exceeds 120W.
- The prior NCC and NPC cards, those with part numbers EXN-002 and EXS-001 respectively, must only be retained where node loadings do not exceed 120W.



**CAUTION:** *When planning the number and type of cards to be installed in an INUe or INU, the following rules must be observed. These rules apply retrospectively (back to software release 5.04).*



**CAUTION:** *The loading rules below must be observed by the installer - there is no built-in mechanism to report or limit an incorrect dimensioning of power supply consumption.*

#### **INUe Loading Rules for Operation up to 55°C (131°F)**

The following loading rules must be followed when dimensioning the total power consumption of an INUe that is required to operate in ambient temperatures up to 55°C (131°F):

- If the total power consumption of all cards installed exceeds 85W, an NPC must be fitted, a 2RU FAN card must be fitted, and 5.04 or later SW loaded.
- With this configuration confirmed (NPC + 2RU FAN + 5.04 SW or later) the maximum INUe loading enabled is:
  - 120W with NCC EXN-002 and NPC EXS-001.
  - 125W with high-output NCC EXN-003 and NPC EXS-002.
  - The installed total of DAC GE3 cards must not exceed four.
- If an earlier version of SW is loaded, the maximum INUe loading allowed is 85 Watts. This applies whether or not an NPC and 2RU FAN are fitted.



**CAUTION:** *55°C (131°F) operation does not apply to the PCC. Operational ambient temperatures with a PCC installed must not exceed 45°C (113°F).*

Install a suitable external +24 Vdc to -48 Vdc converter to avoid the PCC operational ambient temperature limits. Contact Aviat Networks for details.

### INUE Loading Rules for Operation up to 45°C (113°F)

The following loading rules must be followed when dimensioning the total power consumption of an INUE that is operating in ambient temperatures that do not exceed 45°C (113°F):

- If the total power consumption of all cards installed exceeds 85W, an NPC must be fitted, a 2RU FAN card must be fitted, and 5.04 or later SW loaded.
- With this configuration confirmed (NPC + 2RU FAN + 5.04 SW or later) the maximum INUE loading enabled is:
  - 120W with NCC EXN-002 and NPC EXS-001.
  - 146W with high-output NCC EXN-003 and NPC EXS-002.
  - The installed total of DAC GE3 cards must not exceed four.
- If an earlier version of SW is loaded, the maximum INUE loading permitted is 100W. This applies whether or not an NPC and 2RU FAN are fitted.

Typical compliant loading examples are shown below with 5.04 SW or later (48Vdc power source).

**Table 12.** NCC EXN-002 with EXS-001, 45°C (113°F)

Total Watts:	119	118	120	120
Qty RAC 60E	6	0	0	6
Qty RAC 6x	0	4	4	0
Qty DAC 16xV2	0	1	2	0
Qty AUX	0	1	0	1
Qty NPC	1	1	1	1
Qty NCC	1	1	1	1
Qty FAN	1	1	1	1
Qty DAC GE3	2	2	2	2

**Table 13.** NCC EXN-003 with EXS-002, 45°C (113°F)

Total Watts	139	135	132	146
Qty RAC 60E	2	4	4	0
Qty RAC 6XE	4	2	0	4
Qty DAC 16xV2	0	2	4	2
Qty AUX	0	1	1	0
Qty NPC	1	1	1	1
Qty NCC	1	1	1	1
Qty FAN	1	1	1	1
Qty DAC GE3	2	2	4	4

### INU Loading Rules

The INU (1RU) chassis should not be loaded above the follow limits:

- 65 watts total for operation up to 45°C
- 50 watts total for operation up to 55°C

- A maximum of two DAC GE3 cards.

No improvements are introduced for the INU with 5.04 SW due to its use of smaller, lower volume cooling fans.



**NOTE:** Elevated ambient temperatures should be avoided. The ambient temperature is the air temperature in the immediate operating environment of the chassis, which if installed in a rack, is the ambient applying to its location within the rack.



**CAUTION:** *The ambient temperature maximums must not be exceeded. Over-temperature operation is a primary factor affecting long term component reliability.*

## PCC +24 Vdc Operation

The PCC is for use with standard +24 Vdc (-ve grounded) battery-backed power supply systems.

- One PCC supports:
  - Up to 200W in air-conditioned installations (ambient max 25<sup>0</sup>C / 77<sup>0</sup>F)
  - Up to 150W in non-air-conditioned installations (ambient max 45<sup>0</sup>C / 113<sup>0</sup>F).
  - Refer to power consumption figures above to determine a load maximum for a particular configuration.
- The PCC +ve and -ve input terminals are isolated from chassis (ground). The -ve input is grounded by the -ve grounded power supply connection.
- The PCC 20A fuse is fitted in the +ve input. It is a PCB mount type and is not field replaceable.
- Reverse polarity protection is provided. The PCC will automatically recover from a reverse polarity connection - the fuse will not blow. Over temperature thermal protection is included.
- The PCC conversion efficiency is nominally 10%. To determine the power consumed by the PCC, use a figure of 10% of the power consumed by the INU/INUe cards and RFUs (ODU / IRU 600).
- When installed in an INUe the INUe must be fitted with the 2RU FAN module as it provides almost double the air flow of the 1RU FAN modules.
- The PCC must be connected to the NCC before applying power to the PCC to avoid a current-inrush trip (overload) on the PCC.
- The PCC can be plugged into any INU/INUe option slot. It is not connected to the backplane and its function is not monitored within Portal.
  - The PCC should be installed next to the FAN card to get best air-flow cooling.
- Where an NPC is fitted, two PCCs are required for +24 Vdc operation, one for the NCC, the other for the NPC. This means an INUe must be used for NCC + NPC

operation.

- If the PCC front-panel LED is not lit, it indicates the existence of abnormal conditions such as output under-voltage, output over-voltage, loss of input power, output over-current, or open input fuse.

**NOTE:** The PCC function can be replaced by a suitable external +24 Vdc to -48 Vdc converter. Contact Aviat Networks for details.

## Power Cables

The INU power cable is supplied in the IDC Installation Kit. It is supplied with a D-sub M/F 2W2 connector fitted at one end and wire at the other. The cable is nominally 5 m (16 ft), and the wires are 4 mm<sup>2</sup> (AWG 12).

The cable is used for -48 Vdc connections to an NCC or NPC, or for +24 Vdc connections to a PCC.

The blue wire must be connected to live (-48 Vdc or +24 Vdc); the black wire to ground (+48 Vdc or -24 Vdc).

**Figure 43.** Power Cable and Connector



**CAUTION:** Use the INU circuit breaker as the power connect/disconnect device - do not use the front-panel 2W2 DC connector for live power connect/disconnect.

The PCC is supplied with a power cable to connect to an NCC or NPC.

Similarly, the optional NEBS power line filter unit is supplied with a power cable to connect to an NCC, NPC, or PCC.

This cable is fitted with a D-sub M/F 2W2 connector at each end. Note that a standard power cable is not included for the reason the cable supplied with an NCC (or NPC) is not used when powered from a PCC, or via a power line filter, so the cable is re-used as the power input cable for the PCC or filter unit.



## Fuses

The NCC and NPC are fitted with a fast-acting 25 A fuse fitted on the PCB behind the power cable connector. (Early production NCCs were fitted with a front panel fuse/switch with a 12.5 A slow-blow fuse).

The PCC is fitted with a fast-acting PCB-mounted 20A fuse.

NCC, NPC and PCC fuses are not field-replaceable.

## FAN Air Filter Option

A fan air filter option is available for installation with the FAN module in an INU, and with the 2RU FAN module in an INUe. Where Eclipse is required to be NEBS (Network Equipment-Building System) compliant, the fan air filter *must* be installed.



**NOTE:** The fan air filter must be inspected regularly and replaced when dust laden. In normal telecommunications equipment-room environments inspection must be at not more than 12 monthly intervals. In other environments where air quality is not controlled, more frequent inspection is required.



**CAUTION:** A heavily dust-laden filter will severely restrict fan air flow and may lead to over-heating.



**NOTE:** Excessive heat is the number one cause of premature equipment aging and failure. To maximize long term component reliability, the fan air filter must not be allowed to become clogged, and ambient temperature limits must not be exceeded.

## Fan Air Filter Installation

For the INUe a fan air filter kit is supplied, comprising a filter frame, filter element, and fastening screw. For the INU the filter it is a single-piece element. It is installed in the INU/INUe to the right side of the FAN module, as illustrated below for an INUe.

Remove the FAN module and slide the air filter into the chassis so that it locates to the right side of the FAN module backplane connector, and up against the chassis side. FAN module removal and replacement does not affect traffic.

Installation instructions are included with the fan filter kit.

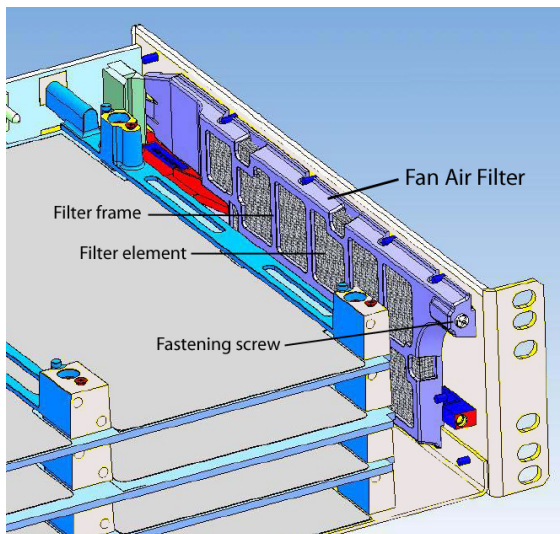
**Figure 44.** Location of Fan Air Filter in INUe

## Power Line Filter Option

An external DC power line filter option is available and must be installed with an INU/INUe for NEBS compliance. It ensures Eclipse meets EMI requirements specified within Telcordia GR-1089-CORE, Issue 4, June 2006.

It is 1RU tall and 140 mm wide (5.5") and is supplied as a kitset comprising the filter unit, bracket for left or right-side rack mounting, and a short 2W2 to 2W2 cable for connecting the filter unit to the NCC or NPC -48 Vdc inputs.









Where an NPC is fitted, two filter units are required, one for the NCC, the other for the NPC.







The standard power cable supplied with an INU or NPC is re-used as the power input cable for the filter unit.

**Figure 45.** Power Line Filter with Bracket

# INU/INUE Installation Requirements

**Table 14.** INU/INUE Installation Requirements

Function/Requirement	Priority	Details
<b>Restricted access</b>	 CAUTION	The INU/INUE and its associated dc power supply must be installed in a restricted access area such as a secure equipment room, closet, or cabinet. For NEBS compliance this equates to installation of the INU/INUE in a secure, restricted access central office (CO) or customer premises (CP) location.
<b>Required Rack Space</b>	 CAUTION	The INU requires 44.5 mm (1RU) of vertical rack space and 300 mm rack depth. The INUE requires 89mm (2RU) vertical rack space and 300 mm rack depth.
<b>Ventilation</b>	 CAUTION	INU/INUE requires unobstructed air passage to <i>each side</i> for ventilation purposes. There must be a minimum of 50 mm (2") of side spacing to any rack panels, cable bundles or similar. No space above or below is required for ventilation purposes.
<b>Maximum Ambient Temperature</b>	 CAUTION	The INU/INUE is specified for a maximum ambient temperature (T <sub>mra</sub> ) of +55° Celsius (131° Fahrenheit). Conditions apply - see <a href="#">INU Power Supply on page 103</a> . The maximum ambient temperature (T <sub>mra</sub> ) applies to the <i>immediate operating environment</i> of the INU, which if installed in a rack, is the ambient applying to its location within the rack.
<b>Physical stability</b>	 CAUTION	Ensure that adding an INU/INUE to a rack does not adversely impact the physical stability of the rack.
<b>Power Supply -48 Vdc</b>	 CAUTION	The INU/INUE PWR modules have the +ve pin on their dc power supply connector connected to the chassis. It must be used with a -48 Vdc power supply which has a +ve ground; the power supply ground conductor is the +ve supply to the INU. The power supply must have an accessible power disconnect device (main switch).
<b>Power Supply +24 Vdc</b>	 CAUTION	A PCC is required to provide a +24 Vdc to -48 VDC conversion. The dc power supply supplying the PCC must be -ve grounded. There must be no switching or disconnecting devices in the ground conductor between the dc power supply and the point of connection to a PCC.
<b>D.C. Supply Ground Connection</b>	 CAUTION	The INU/INUE has a connection between the earthed conductor of the d.c. supply circuit and the earthing conductor. The INU/INUE must be connected directly to the d.c. supply system grounding electrode conductor or to a bonding jumper from a grounding terminal bar or bus to which the d.c. supply system grounding electrode is connected. Switching or disconnecting devices must not be in the grounded circuit conductor between the d.c. source and the point of connection of the grounding electrode conductor.

Function/Requirement	Priority	Details
<b>Equipment Location</b>	 CAUTION	INU/INUE must be located in the same immediate area (such as, adjacent cabinets) as any other equipment that has a connection between the grounded conductor of the same d.c. supply circuit and the grounding conductor, and also the point of grounding of the d.c. system. The d.c. system shall not be grounded elsewhere.
<b>Location of D.C. Power Supply</b>	 CAUTION	The d.c. supply source for INU/INUE must be located within the same premises as the INU/INUE.
<b>D.C. Supply Compliance, Loading and Protection</b>	 CAUTION	<p>The dc power supply must be UL or IEC compliant for a SELV output (60 Vdc maximum).</p> <p>Check to ensure that connection of an INU/INUE to a new or existing dc supply does not overload the supply, circuit protection devices and wiring.</p> <p>The INU/INUE and optional NPC module must each be supported from a dedicated circuit breaker located on their rack power distribution panel.</p> <p>The circuit breaker(s) should have a rating of:</p> <ul style="list-style-type: none"> <li>12 A for the INU, and for optional NPC</li> <li>25 A for the INUE, and for optional NPC</li> <li>15A for the PCC</li> </ul> <p>The circuit breaker(s) must be used as the INU/INUE power connect/disconnect devices - do not use the front panel connectors as connect/disconnect devices.</p> <p>For NEBS compliance the battery return connection is to be treated as a common DC return (DC-C), as defined in GR-1089-CORE.</p>
<b>Cable routing</b>	 CAUTION	INU/INUE Cat5, tributary, auxiliary and NMS cables are not to be routed with any AC mains power lines. They are also to be kept away from any power lines which cross them.
<b>Chassis Grounding</b>	 CAUTION	The INU/INUE chassis must be grounded to the station or master ground, which must be the same ground as used for the dc power supply. Normally this is achieved by grounding the INU/INUE to the ground bar in its equipment rack or frame. This bar is most often located to one side of the rack or at rack top or bottom. In turn, the ground bar is grounded to the station ground.
<b>Fan Air Filter</b>	 CAUTION	The fan air filter must be installed where the INU/INUE is required to be NEBS compliant. The filter must be inspected regularly and replaced when dust laden. Inspection must be at not more than 12 monthly intervals in controlled air environments, or more frequently otherwise.
<b>Power Line Filter</b>	 CAUTION	The power line filter must be installed where the INU/INUE is required to be NEBS compliant.
<b>Compact Flash Card Compatibility</b>		Where plug-in cards such as RAC 60E, RAC 6XE , DAC GE3, are to be installed into an existing INU, first ensure the Compact Flash card fitted in the NCC will support the required capacity. See <a href="#">Compact Flash Card on page 1</a> .
<b>NCC Compatibility</b>		<p>Where a higher capacity Compact Flash Card is to be installed into an existing INU/NCC (NCC V2) to support RAC 60E, RAC 6XE, DAC GE3 operation, first ensure NCC compatibility with higher capacity Compact Flash cards. See <a href="#">Compact Flash Card on page 1</a>.</p> <p>For information on NCC V1 / NCC V2 compatibility refer to <a href="#">Plug-in Installation Requirements on page 121</a>.</p>

Function/Requirement	Priority	Details
<b>Intrabuilding interfaces and cabling (NEBS Compliance)</b>	 CAUTION	<p>Intrabuilding connections to/from Eclipse ports must only be connected via intrabuilding or unexposed wiring or cabling.</p> <p>Intrabuilding ports MUST NOT be metalically connected to interfaces that connect to the OSP or its wiring. These interfaces are designed for use as intrabuilding interfaces only (Type 2 or Type 4 ports as described in GR-1089-CORE, Issue 4) and require isolation from the exposed OSP cabling. The addition of Primary Protectors is not sufficient protection in order to connect these interfaces metalically to OSP wiring.</p> <p>Shielded and grounded cables must be used for intrabuilding cabling to/from Eclipse ports. Cables must be grounded at both ends.</p>

# Installation

---

## Procedure

- Fit the rack mounting ears to the chassis with the grounding stud to left or right side for the most direct ground wire path to the rack ground bar.
- Locate the INU/INUE in the equipment rack and secure it using four No.12 Phillips dome-head screws from the IDC installation kit.
- Ground the INU/INUE from the grounding stud to the rack/frame ground bar using a length of 4 mm<sup>2</sup> (AWG 12) green PVC insulated stranded copper wire with a suitably sized ground lug at the ground bar end (supplied by the installer). The grounding stud accommodates ground cables up to 16 mm<sup>2</sup> (AWG 6). The stud also provides jack plug connection for a wrist strap.
- If the equipment rack/frame requires grounding, use 16 mm<sup>2</sup> (AWG 6) wire from its ground bar to the station ground.

### Grounding Safety:

- Do not assume that an existing rack or mounting frame is correctly grounded. Always check the integrity of the ground connections, which must include a check through to the master ground for the station, which should be located at the point of cable entry to the equipment building. Ground wires must provide a direct, low impedance path to the master ground bar.
- Do not connect other equipment to the same grounding cable as the INU. Each item of equipment in a rack must be separately grounded to the rack ground bar.
- The INU must be located in the same immediate area (adjacent racks/cabinets) as all other equipment with a (ground) connection to a common DC supply source.

### For NEBS compliance:

- Install the fan air filter option. Options are available for the IRU INU and IRU INUE. See [FAN Air Filter Option on page 113](#).
- Install the NEBS power line filter unit. Install immediately below or above the INU. Separate filter units are required for the NCC and, where fitted, the NPC. Use the supplied 2w2 to 2w2 cable to connect the output of the filter unit to the input of the NCC or NPC.
- To ground the INU use 16 mm<sup>2</sup> (AWG 6) green PVC insulated stranded copper wire together with a star washer under the grounding screw at the ground-bar end. Torque the INU grounding post screw to 1.2-1.5 Nm (10-13 in-lbs).

- All bare conductors must be coated with an appropriate antioxidant compound before crimp connectors are fitted.
- All unplated connectors, braided strap, and bus bars must be brought to a bright finish and then coated with an antioxidant before they are connected. This does not apply to tinned, solder-plated, or silver-plated connectors and other plated connection surfaces – but all must be clean and free of contaminants.
- All raceway fittings must be tightened to provide a permanent low-impedance path.
- Install the plug-ins in their assigned slot positions, and check that their front panels are flush-fitted (not protruding) and held secure by their fasteners. Ensure unused slots are covered by blanking panels. See [See "Plug-in Slot Configuration"](#), and [Plug-in Installation Requirements on page 121](#).
  - If a FAN air filter is required, fit it prior to inserting the FAN.
  - Install the CompactFlash card in the NCC; insert in the socket on the right side of the PCB.
- For an ODU, fit the supplied jumper cable between the RAC and ODU cable, or where required to a lightning surge arrester. See [Arrester Installation at Building Entry on page 1](#). Secure the cable within the rack/frame using cable ties or similar. If the jumper cable is too short, make an extension cable. See [Jumper Cables on page 1](#).
- For an IRU 600, fit the supplied jumper cable between the RAC and companion IRU 600 RFU.
- Fit the DAC tributary cables. For information on the tributary cable sets, refer to [See "INU/INUE and IDU Connector and Cable Data"](#)



**NOTE:** For a DAC 16x, ensure correct orientation of the Mini RJ-21 connector before pushing it home. This can be checked by the scalloped key to one side of the connector. Additionally, a tributary cable supplied by Aviat Networks will have the cable exiting to the right side when viewed from the front. Do NOT over-tighten the Mini RJ-21 retaining screws.

The following steps describe the procedure for installing the power cable and preparing for power-on. *Do not connect* the power until *all* steps have been completed.

- Run the supplied power cable through to the power pick up point, which will normally be at a circuit breaker panel in the rack. A circuit breaker (or fuse) should have a capacity of 12 A for the INU and a 25 A for the INUE, however these ratings can be adjusted in line with the number of cards installed, and hence power consumption. For power consumption data, see [INU Power Supply on page 103](#).
- For a -48 Vdc supply, connect the blue wire to -48 Vdc (live), and the black wire to ground/+ve. (Power input on the NCC and NPC is polarity protected).
- For a +24 Vdc supply, connect the blue wire to +24 Vdc (live), and the black wire

to ground/-ve. (Power input on the PCC is polarity protected).

- Measure the voltage on the dc power connector.
  - For -48 Vdc operation the voltage should be -48 Vdc, +/- 2 Vdc for a non-battery floated supply, and nominally -56 Vdc for a battery floated supply. (Limits are - 40.5 to - 60 Vdc).
  - For +24 Vdc operation the voltage should be 24 +/- 2 Vdc for a non-battery floated supply, and nominally 30 Vdc for a battery floated supply. (Operating limits are 20 to 36 Vdc).



**NOTE:** This product meets the global product safety requirements for SELV (safety extra low voltage) rated equipment and the input voltage must be guaranteed to remain within the SELV limits (60 V maximum) in the event of a single internal fault.

Always check the integrity of the dc power supply to an INU/INUE *right to its source*. Never assume that the supply provided to the pick-up point in a rack is correct.

Eclipse dc power, IF, tributary, auxiliary and NMS cables are not to be routed with any AC mains power lines. They are also to be kept away from any AC power lines which cross them.

- Carry out a complete check of the installation. When all is checked and correct, the INU is ready for power-on.
  - If a PCC is installed, ensure the PCC to NCC/NPC cable is correctly fitted before power-on.



**CAUTION:** Once powered up the radio frequency units will be transmitting with the pre-configured or ex-factory frequency and power settings unless the start-up transmit mute option has been invoked. (All ODUs/RFUs shipped ex-factory have the transmit-mute set as the default unless otherwise specified). If frequency and power settings are not correct, interference can be caused to other links in the same geographical area.

- Turn power on. For -48 Vdc connect the power cable to the NCC, and to the NPC where fitted. For +24 Vdc operation, connect to the PCC input.
  - Where a power line filter is installed (for -48 Vdc), connect to the filter input.



**CAUTION:** Do not turn off an INU/INUE within 10 minutes of initial turn-on, or initial turn-on after a new compact flash card is installed.



**CAUTION:** 2W2 DC power connectors can be shorted inadvertently if applied at an angle. Always insert with correct alignment.



**CAUTION:** Ambient temperatures must not exceed 55°C (131°F). If installed in a rack cabinet, it is the ambient within the cabinet.

The Eclipse INU is ready for configuration and antenna alignment.





# Plug-in Installation Requirements





The table below details the plug-in requirements at installation. Unless specified by the customer, plug-ins will not be installed in an INU/INUE at shipment. Instead, each is individually packed within the shipping box.



For a description of the plug-ins, see the *Eclipse Platform Product Description*. For configuring plug-ins, see [Node and Terminal Plug-ins on page 1](#).

For information on user-interface connector and cable data, refer to [INU/INUE and IDU Connector and Cable Data on page 1](#).

**Table 15.** Plug-in Requirements

Function/Requirement	Priority	Details
<b>Slot Assignment</b>		
All slots filled	 CAUTION	All slots must be filled with either a plug-in or a blanking panel. Failure to do so will compromise EMC integrity and distribution of FAN cooling air.
Universal slots 1-4 on an INU 1-6 on an INUE		RAC, DAC, NCM, and AUX plug-ins can be fitted in any universal slot.
Restricted slots 7-9 on an INUE		DAC, NCM, and AUX plug-ins can be fitted in any restricted slot. The exceptions are the DAC 155oM, DAC 155eM, and AUX, which must only be installed in slots 1 to 6 <i>when they are to be configured to carry/access Eclipse NMS</i> , otherwise they can be installed in slots 7 to 9.
Dedicated slots		The NCC, FAN, and NPC plug-ins have dedicated slots.
Protected RACs INUE		Protected RACs (or ring-protected RAC with DAC 155oM) must only be installed in 'above and below' slots as indicated by the red arrows.
AUX		Multiple AUX plug-ins can be installed per INU/INUE.
NPC		Only one NPC is required to provide the NCC protection option. An NPC must be installed in slot 4 of an INU, or slot 10 of an INUE. If an NPC is not installed in an INU, slot 4 is available as a universal slot.
<b>Installing / Changing Plug-ins</b>		
ESD grounding strap	 CAUTION	Always connect yourself to the INU/INUE with an ESD grounding strap before changing or removing a plug-in. Failure to do so can cause ESD damage to the plug-ins. Avoid hand contact with the PCB top and bottom.

Function/Requirement	Priority	Details
Finger-grip fasteners	 CAUTION	Plug-ins must be withdrawn and inserted using their finger-grip fasteners/pulls. Never withdraw or insert using attached cables, as damage to the plug-in connector and its PCB attachment can occur. If not complied with, the Aviat Networks warranty may be voided.  <b>Do not over-tighten fasteners. Hand-tighten or use only light screwdriver pressure.</b>
Hot-swappable	 CAUTION	Plug-ins are hot-swappable. Removal of an in-service payload plug-in will interrupt its traffic. Removal of the NCC will affect all traffic - unless protected by an NPC. Removal / replacement of the FAN does not affect traffic.
Engaging backplane connector		When installing a plug-in, ensure its backplane connector is correctly engaged before applying sufficient pressure to bring the plug-in panel flush with the front panel.
Revision time lag		When swapping or installing plug-ins, up to 60 seconds can be required for the INU/INUE to show its revised status via the front panel LEDs, or via Portal.
EMC integrity	 CAUTION	Plug-ins and blanking panels are held in place by captive finger-screws. Ensure the finger-screws are fastened as failure to do so may compromise EMC integrity and fan cooling.
<b>NCCs</b>		
NCC Versions	 CAUTION	There are two NCC versions: V1 and V2. NCC V2 is recognized by the 4-port Ethernet NMS assembly, no front panel fuse holder, and a 2W2C D-series power connector. NCC V1 (obsolete) has a three port Ethernet NMS assembly, a front panel fuse holder, and a small two-pin power connector. The latest software version to support NCC V1 is 5.01.44. If attempts are made to upgrade an INU with an NCC V1 to 6.0 software, the action will not be executed; the software load will fail and the NCC will remain at the version it was originally loaded with.  Operation and inter-operation parameters for these two versions are as follows: NCC V1 and NCC V2 can be used within the same network. NCC V1 is only suitable for the INU. It will not operate in the INUE. NCC V2 supports <i>both</i> INU and INUE. NCC V1 only supports the power supply redundancy capability of the NPC plug-in option. It does not support NPC redundancy for backplane bus management (bus clock). NCC V2 supports NPC redundancy for power supply <i>and</i> backplane bus management.
<b>RACs</b>		

Function/Requirement	Priority	Details
Connecting and disconnecting the ODU cable at the RAC	 <p>CAUTION</p>	<p>Never disconnect or reconnect an ODU or IRU 600 RFU cable to a RAC without first turning the power off to the INU or withdrawing the RAC from the backplane.</p> <p><b>NOTE:</b> The ODU/RFU cable provides the power feed to the ODU/RFU. Arcing during connection and disconnection at the RAC on a live RAC can cause damage to connector contact surfaces. Power spikes caused by live connection and disconnection may also cause errors on other traffic passing through the INU/INUE. The only exception to live disconnection and connection should be for checks of protected operation at link commissioning.</p>
Removing RAC from a powered INU	 <p>CAUTION</p>	<p>When removing a RAC from a powered INU, always the disengage the RAC from the backplane before disconnecting its ODU cable. Similarly, before inserting an RAC, always reconnect the ODU cable before engaging the backplane.</p>
RAC combinations for INUE		<p>An INUE can be fitted with a maximum of six RACs for one of the following combinations:</p> <ul style="list-style-type: none"> <li>Six non-protected links</li> <li>One protected/diversity link plus four non-protected links</li> <li>Two protected/diversity links plus four non-protected links</li> <li>Three protected/diversity links</li> </ul> <p><i>Before installing more than four RACs refer to the Power Consumption and INU Load Maximums in <a href="#">INU Power Supply on page 103.</a></i></p>
<b>DACs</b>		
DAC combinations		<p>DACs can be fitted singly or in combination to provide a mix of interface types and capacities provided they have a common backplane configuration. The backplane can be set for:</p> <ul style="list-style-type: none"> <li>- 2 Mbit/s / E1</li> <li>- 1.5 Mbit/s / DS1</li> <li>- 8 Mbit/s / E3</li> <li>- 3 Mbit/s / DS3</li> <li>- 155 Mbit/s / STM1/OC3</li> </ul> <p>Mux version DACs allow a mix of interfaces from a common E1 or DS1 backplane configuration.</p>
Increasing node capacity		<p>To achieve a greater node capacity, two or more INUs can be interconnected via a DAC option.</p>
DAC 16x Mini RJ-21 tributary cable connector, or DAC 16xV2/V3 HDR tributary cable connector	 <p>CAUTION</p>	<p>Ensure correct orientation of the Mini RJ-21 connector on DAC 16x before pushing it home. This can be checked by the scalloped key to one side of the connector. Additionally, a tributary cable supplied by Aviat Networks will have the cable exiting to the right side when viewed from the front.</p> <p><b>Ensure the connector retaining screws are not over-tightened - hand tighten or use only light screwdriver pressure.</b></p>

Function/Requirement	Priority	Details
Line Protection (electrical DACs)		Line (interface) protection is supported for paired E1/DS1, E3/DS3 and STM1 electrical DACs.
Line Protection (optical DACs)		Line (interface) / card protection is supported for paired STM1/OC3 optical DACs.
Interface Protection, Ethernet DAC GE3		Interface / card protection is supported for paired DAC GE3 cards.
<b>NCM</b>		<p>Installed for E1 or DS1 loop switch operation.</p> <p>Two are installed for protected operation.</p> <p>One NCM (1+0 or 1+1) supports up to 8 E1 or DS1 tributaries directly on HDR connectors.</p> <p>One or more DAC 16xV2/V3s are additionally installed at sites requiring access to more than 8 tribs.</p> <p><b>Ensure the tributary connector retaining screws are not over-tightened - hand tighten or use only light screwdriver pressure.</b></p>
<b>General</b>		
Maximum Single Link Capacity via Eclipse Node backplane		<p>The maximum drop, through plus drop, or through capacity of an Eclipse Node comprising one INU/INUe is one of the following, depending on the backplane setting:</p> <ul style="list-style-type: none"> <li>200 Mbit/s / 100x E1</li> <li>196 Mbit/s / 127xDS1</li> <li>4xDS3</li> <li>310 Mbit/s / 2xSTM1/OC3</li> </ul>
Maximum Single Link Capacity via DPP (RAC 60/60E/6X/6XE DPP connected to DAC GE or DAC GE3)		366 Mbps for Ethernet traffic or mixed-mode Ethernet with TDM, using a 256 QAM maximum throughput modulation profile. This is the link (air) capacity. If all traffic is Ethernet, the nominal L2 throughput maximum is 365 Mbps (1518 byte frames); the nominal L1 throughput maximum is 465 Mbps (64 byte frames).
Antistatic bags		Enclose spare plug-ins, or plug-ins to be returned for service, in an antistatic bag. When handling a plug-in to or from an antistatic bag, do so at the INU/INUe and only when you are connected to the INU/INUe via an ESD ground strap.
Spare blank panels		Keep any removed blanking panels for future use.

## Appendix A. Antennas certified for use with IRU 600v4 at 5.8GHz

The following table lists all the antennas certified for use with IRU 600v4 at 5.8GHz.

Manufacturer	Part Number	Antenna Gain (dBi)	Antenna Size ft (meters)	Antenna Type
RFS	MA0528-19AN	19	0.5	Flat panel
RFS	MA0528-23AN	23	1	Flat panel
RFS	MA0528-28AN	28	2	Flat panel
RFS	SPF2-52CN1S	28.5	2 (0.6)	Parabolic
RFS	SPF3-52CN1S	32	3 (0.9)	Parabolic
RFS	SPF4-52CN1S	34.4	4 (1.2)	Parabolic
RFS	SPF6-52CN1S	38.1	6 (1.8)	Parabolic
RFS	SDF3-52CN1S1	32	3 (0.9)	Parabolic
RFS	SDF4-52CN1S1	34.4	4 (1.2)	Parabolic
RFS	SDF6-52CN1S1	38.1	6 (1.8)	Parabolic
RFS	UXA6-U57AC	39	6 (1.8)	Parabolic
RFS	UXA8-U57AC	41.6	8 (2.4)	Parabolic
RFS	PADX6-U57AC1S1R	38.9	6 (1.8)	Parabolic
RFS	PADX8-U57AC1S1R	41.4	8 (2.4)	Parabolic
RFS	PAD6-59BC1S1R	38	6 (1.8)	Parabolic
RFS	PAD8-59AC1S1R	40.7	8 (2.4)	Parabolic
RFS	SU6-59By	38.1	6 (1.8)	Parabolic
RFS	SU4-59By	34.7	4 (1.2)	Parabolic
RFS	DA6-59BC	38.4	6 (1.8)	Parabolic
RFS	DA8-59Ay	40.9	8 (2.4)	Parabolic
RFS	UA8-59Ay	40.9	8 (2.4)	Parabolic
RFS	SUX6-59By	37.8	6 (1.8)	Parabolic
RFS	SUX4-59Ay	33.8	4 (1.2)	Parabolic
RFS	DAX4-59AC	33.8	4 (1.2)	Parabolic
RFS	DAX6-59BC	38	6 (1.8)	Parabolic
RFS	DAX8-59Ay	40.7	8 (2.4)	Parabolic
RFS	UXA4-59Ay	33.8	4 (1.2)	Parabolic
RFS	UXA6-59Cy	38	6 (1.8)	Parabolic

APPENDIX A, ANTENNAS CERTIFIED FOR USE WITH IRU 600V4 AT 5.8GHZ

Manufacturer	Part Number	Antenna Gain (dBi)	Antenna Size ft (meters)	Antenna Type
RFS	UXA8-59By	40.6	8 (2.4)	Parabolic
RFS	PADX6-W59BC1S1R	37.9	6 (1.8)	Parabolic
RFS	PADX8-W59AC1S1R	40.4	8 (2.4)	Parabolic
RFS	UXA6-W59BC	38.1	6 (1.8)	Parabolic
RFS	UXA8-W59AC	40.6	8 (2.4)	Parabolic
RFS	SC3-W60y	31.5	3 (0.9)	Parabolic
RFS	SB4-W60y	34.3	4 (1.2)	Parabolic
RFS	SB6-W60y	38.2	6 (1.8)	Parabolic
RFS	SCX3-W60y	31.5	3 (0.9)	Parabolic
RFS	SBX4-W60y	34.3	4 (1.2)	Parabolic
RFS	SBX6-W60y	38.2	6 (1.8)	Parabolic
RFS	PA4-W57BC1S1	35.5	4 (1.2)	Parabolic
RFS	PA6-W57BC1S1	39	6 (1.8)	Parabolic
RFS	PA8-W57AC1S1	41.5	8 (2.4)	Parabolic
RFS	PAD6-W57BC1S1R	38.9	6 (1.8)	Parabolic
RFS	PAD8-W57AC1S1R	41.4	8 (2.4)	Parabolic
RFS	PADX6-W57AC1S1R	38.7	6 (1.8)	Parabolic
RFS	PADX8-W57AC1S1R	41.2	8 (2.4)	Parabolic
RFS	DA6-W57BC	39	6 (1.8)	Parabolic
RFS	DA6-W57BC	41.5	8 (2.4)	Parabolic
RFS	UXA6-W57AC	38.9	6 (1.8)	Parabolic
RFS	UXA8-W57AC	41.4	8 (2.4)	Parabolic
CommScope	P4F-52/A	34.9	4	Parabolic
CommScope	P6F-52/A	37.6	6	Parabolic
CommScope	PX4F-52/A	34.9	4	Parabolic
CommScope	PX6F-52/A	37.6	6	Parabolic
CommScope	P4F-57W/A	35	4	Parabolic
CommScope	P6F-57W/A	38.5	6	Parabolic
CommScope	P8F-57W	41.2	8	Parabolic
CommScope	P10F-57W	42.9	10	Parabolic
CommScope	P4-57W/A	35	4	Parabolic
CommScope	PL6-57W/A	38.5	6	Parabolic
CommScope	PL8-57W	41.2	8	Parabolic
CommScope	PL10-57W	42.9	10	Parabolic
CommScope	HP4F-57W/A	35	4	Parabolic

<b>Manufacturer</b>	<b>Part Number</b>	<b>Antenna Gain (dBi)</b>	<b>Antenna Size ft (meters)</b>	<b>Antenna Type</b>
CommScope	HP6F-57W/A	38.5	6	Parabolic
CommScope	HP8F-57W	41.2	8	Parabolic
CommScope	HP10F-57W	42.9	10	Parabolic
CommScope	HP4-57W/A	35	4	Parabolic
CommScope	HP6-57W/A	38.5	6	Parabolic
CommScope	HP8-57W	41.2	8	Parabolic
CommScope	HP10-57W	42.9	10	Parabolic
CommScope	PAR8-59	40.2	8	Parabolic
CommScope	PARX8-59	40.2	8	Parabolic
CommScope	HX6-6W	39.1	6	Parabolic
CommScope	USX6-6W	38.4	6	Parabolic
CommScope	HP6-59	37.9	6	Parabolic
CommScope	HP8-59	40.8	8	Parabolic
CommScope	HP10-59	42.3	10	Parabolic
CommScope	HP12-59	44.4	12	Parabolic
CommScope	PARX8-59	40.1	8	Parabolic
CommScope	PARX10-59	42.4	10	Parabolic
CommScope	UHX6-59	38.1	6	Parabolic
CommScope	UHX8-59	40.6	8	Parabolic
CommScope	UHX10-59	42.6	10	Parabolic
CommScope	UHX12-59	44.1	12	Parabolic
CommScope	HPX4-59	34.1	4	Parabolic
CommScope	HPX6-59	38.1	6	Parabolic
CommScope	HPX8-59	40.6	8	Parabolic
CommScope	HPX10-59	42.4	10	Parabolic
CommScope	PAR8-59	40.1	8	Parabolic
CommScope	PAR10-59	42.7	10	Parabolic

260-668066-001

[WWW.AVIATNETWORKS.COM](http://WWW.AVIATNETWORKS.COM)