

# **μLink Digital Radio**

## **System Manual**

**Publication Number: 862-01545**

**Issue 1b**  
**February 1999**

Tellumat (Pty) Limited  
Reg. No. 96/000957/07  
64/74 White Road, Retreat, 7945  
P.O. Box 30451, Tokai, 7966  
Telephone: +27 21 710-2911  
Fax No. +27 21 710-2333

## Federal Communications Commission Notice

### NOTE

The equipment has been tested and found to comply with the limits for a Class A digital devices, pursuant to Part 15 of the FCC Rules.

These limits are designed to provide reasonable protection against harmful interference when the equipment is operated in a commercial environment. This equipment generates, uses, and can radiate radio frequency energy and, if not installed and used in accordance with the instruction manual, may cause harmful interference to radio communications.

Operation of this equipment in a residential area is likely to cause harmful interference in which case the user will be required to correct the interference at his own expense.

The manufacturer is not responsible for any radio or TV interference caused by unauthorised modifications to this equipment. Such modifications could void the user's authority to operate the equipment.

This device complies with Part 15 of the FCC Rules. Operation is subject to the following two conditions: (1) this device may not cause interference, and (2) this device must accept any interference, including interference that may cause undesired operation of the device.

**This equipment must be professionally installed.**

	<p><b>WARNING- To comply with FCC RF exposure limits, the antennas for this transmitter must be fix-mounted to provide a separation distance of 1 meter (3.5 ft) or more from all persons to satisfy RF exposure requirements.</b></p>
---	--

**Document Issue Status**

When an issue status of this manual changes, the record below must be completed and initialled.

<b>Page No.</b>	<b>Issue Status</b>	<b>Authority (ECN No.)</b>	<b>Page No.</b>	<b>Issue Status</b>	<b>Authority (ECN No.)</b>
1 - 78	1				
1 - 82	1b				

## Table of Contents

	<b>Page</b>
<b>Chapter 1: Purpose and Planning .....</b>	<b>1</b>
Introduction to Chapter 1 .....	1
μLink Product Family .....	1
Role and Purpose.....	1
System Description.....	2
System Overview.....	2
Features.....	2
System Configuration Options.....	5
Interface Definitions.....	6
Planning Information .....	7
Site Evaluation .....	7
Multipath Effects .....	8
Installation Information.....	9
General Information .....	9
Indoor Unit.....	9
Outdoor Unit and Antenna.....	9
Operational Capabilities .....	10
Maintenance Features.....	11
Built-in Test Features .....	11
System Specifications .....	12
Performance Characteristics.....	12
Data Transmission Characteristics .....	12
Transmitter Characteristics.....	13
Receiver Characteristics.....	13
Wayside Service Channel.....	14
Auxiliary/Alarm Interfaces .....	14
Power Supply Characteristics.....	15
Controls and Displays.....	15
Antenna Characteristics (μLink -T) .....	16
Equipment Status Monitoring .....	17
Mechanical Characteristics .....	18
Environmental Characteristics.....	18
Frequency Band Plan.....	19

<b>Chapter 2: Installation</b> .....	21
Introduction to Chapter 2.....	21
Site Requirements.....	21
Parts and Accessories Supplied for Installation.....	22
Customer Furnished Tools and Equipment.....	23
Installation Overview.....	24
Antenna Installation.....	24
Outdoor Unit Installation.....	26
Indoor Unit Installation.....	29
Interconnection Cable Installation.....	31
System Commissioning.....	33
Information Required.....	33
Commissioning Procedure.....	33
Setting-up Procedure.....	33
Beaming-up.....	33
Set Critical Parameters.....	33
Link Error Performance Test.....	34
Appendix A to Chapter 2:.....	35
μLink External Connector Pin Details.....	35
Indoor Unit Connector Pin Details.....	35
Outdoor Unit Connector Pin Details.....	38
<b>Chapter 3: Operational Information</b> .....	39
Introduction to Chapter 3.....	39
Indoor Unit (IU) Controls, Indicators and Connectors.....	39
Front Panel.....	39
Indoor Unit (IU) Controls, Indicators and Connectors.....	43
Rear Panel.....	43
<b>Chapter 4: μLink Management System</b> .....	45
General Information.....	45
Hardware (supplied by Customer).....	45
Software and Hardware (supplied by Tellumat).....	46
Setting-up.....	46
Accessing the Software Program.....	47
Menu Structure.....	47
Main Screen.....	48
Short-cut Buttons Area.....	49

Station Control Screen .....	51
Indoor Unit: Configuration .....	52
Indoor Unit: Build State.....	53
Indoor Unit: Status .....	54
Outdoor Unit: Configuration.....	58
Outdoor Unit: Build State .....	60
Outdoor Unit: Status .....	61
<b>Chapter 5: Maintenance Information.....</b>	<b>63</b>
Introduction to Chapter 5 .....	63
Fault Diagnosis .....	63
<b>Chapter 6: Functional Description.....</b>	<b>65</b>
Introduction to Chapter 6 .....	65
µLink System Description .....	65
Indoor Unit.....	66
<b>Chapter 7: Parts List.....</b>	<b>67</b>
Introduction to Chapter 7 .....	67
Parts Lists .....	67

## List of Illustrations

<b>Figure</b>	<b>Page</b>
Figure 1. μLink Indoor Unit.....	3
Figure 2. μLink Outdoor Unit and Antenna. ....	3
Figure 3. System Overview Block Diagram.....	4
Figure 4. Multipath Effects. ....	8
Figure 5. Frequency Band Plan. ....	19
Figure 6. μLink Antenna. ....	25
Figure 7. μLink Outdoor Unit. ....	26
Figure 8. Indoor Unit Rear Panel. ....	30
Figure 9. Outdoor Unit Mounted on Antenna.....	32
Figure 10. IU Front Panel Controls, Indicators and Connectors.....	40
Figure 11. IU Rear Panel Controls, Indicators and Connectors.....	43
Figure 12. μLink Management Software: Typical Main Screen.....	48
Figure 13. Typical Station Control Screen.....	50
Figure 14. Indoor Unit: Typical Configuration Screen.....	52
Figure 15. Indoor Unit: Typical Build State Screen. ....	53
Figure 16. Indoor Unit: Typical Status Screen.....	54
Figure 17. Indoor Unit: Typical Failure Alarm Details Screen.....	55
Figure 18. Indoor Unit: Typical Site Alarms and Control Screen.....	56
Figure 19. Indoor Unit: Typical Service Alarm Details Screen. ....	57
Figure 20. Outdoor Unit: Typical Configuration Screen. ....	58
Figure 21. Outdoor Unit: Typical Build State Screen.....	60
Figure 22. Outdoor Unit: Typical Status Screen. ....	61
Figure 23. μLink System.....	68

## List of Tables

<b>Table</b>	<b>Page</b>
Table 1. μLink System Data Interface Variants.....	5
Table 2. μLink System RF Configurations.....	5
Table 3. μLink System: User Services.....	6
Table 4. Link Error Performance Check List.....	34
Table 5. IU Front Panel: Controls, Indicators and Connectors.....	41
Table 6. Status LEDs:.....	42
Table 7. IU Rear Panel: Controls, Indicators and Connectors.....	44
Table 8. μLink System Level Parts List.....	69

## Note to Reader

1. Users must be familiar with the Windows 95 operating environment.

---

© 1999 Tellumat (Pty) Limited

The information contained herein is the property of Tellumat (Pty) Limited and is supplied without liability for errors or omissions. No part may be reproduced, used or disclosed except as authorised by contract or other written permission. The copyright and the foregoing restriction on reproduction, use and disclosure extend to all media in which this information may be embodied, including magnetic or electronic storage etc.



## List of Abbreviations

AC	Alternate Current
AIS	All Ones (“1’s”) (detected)
BER	Bit Error Rate
BPSK	Binary encoded Phase Shift Keying
CBIT	Continuous Built in Test
CRC	Cyclic Redundancy Check
DC	Direct Current
DCE	Data Communications Equipment
DRL	Digital Radio Link
DRS	Digital Radio Station
DTE	Data Terminal Equipment
FPGA	Field Programmable Gate Array
IBIT	Initiated Built in Test
IU	Indoor Unit
LAN	Local Area Network
LED	Light Emitting Diode
LRU	Line Replaceable Unit
MDR	Microwave Digital Radio
MIB	Management Information Base
MMIC	Monolithic Microwave Integrated Circuit
MTBF	Mean Time Between Failure
MTTR	Mean Time To Repair
N.C	Normally Closed
N.O	Normally Open
NMS	Network Management System
OU	Outdoor Unit
PC	Personal Computer
PCB	Printed Circuit Board

PLL	Phase Locked Loop
QPSK	Quadrature Phase Shift Keying
RAM	Random Access Memory
RF	Radio Frequency
SBIT	Start-up Built in Test
SDC	Serial Data Channel
SNMP	Simple Network Management Protocol
SRD	System Requirements Definition
SRU	Shop Replaceable Unit
TMN	Transmission Management Network
TTL	Transistor-Transistor Logic
VSWR	Voltage Standing Wave Ratio
WAN	Wide Area Network

**This page intentionally left blank**



## Chapter 1: Purpose and Planning

---

### Introduction to Chapter 1

Chapter 1 is aimed at management and planning staff to enable them to assess the suitability and logistic requirements of the μLink Digital Radio, hereafter referred to as the μLink.

---

### μLink Product Family

The μLink design philosophy was to produce a range of products, with the data rate dependent purely on the Indoor Unit (IU) and the frequency band dependent purely on the Outdoor Unit (OU). Thus resulting in a common IU that can operate with different frequency OUs, or alternatively, an OU that remains unchanged while the data rate is altered or upgraded. This manual covers the OU with integral 18dBi antenna (EHC, THC referred to as -C), and the OU with N-Type connector for use with a separate antenna (EHD, THD referred to as -D).

---

### Role and Purpose

The μLink operates in the 2.4 GHz ISM frequency band. It provides a full duplex, point-to-point, digital radio link supporting user data rates up to 2048 kbit/s. It is used to transport digital data between two or more sites. Whether the digital information is voice, telephony, cellular, data or video as required by various applications, the μLink can be deployed in urban and rural networks as an interconnect solution.

Typical applications for the system include:

- Telecommunications companies, cellular operators and private carriers using low cost spread spectrum E1/T1 links to substitute for conventional copper or licences band microwave links
  - Providing last mile leg in urban areas where frequency bands are congested
  - Rural communications
  - Corporate Networks
-

## System Description

---

**System Overview** A μLink digital radio relay link (DRL) consists of at least one complementary pair of μLink stations that may be extended over longer distances by linking further station pairs in a multiple hop configuration. A single μLink station comprises an Indoor Unit (Figure 1), an Outdoor Unit and Antenna (Figure 2). The Indoor Unit (IU) and Outdoor Unit (OU) are interconnected by a custom cable. Figure 3 is a block diagram of an μLink DRL.

---

- Features** The μLink offers the following key features:
- T1 and E1 payload data interface options.
  - IU is independent of OU frequency band and the OU is independent of IU data interfaces.
  - Network management features, including remote performance monitoring and configurability are to be included in future upgrade products.
  - The equipment is compact and versatile, enabling fast deployment.
  - The system offers high data link reliability.
  - Maintenance requirements are minimal.
  - The system provides built-in-diagnostic and test features.
  - Co-locate two (2) antennas on a single mast.
-

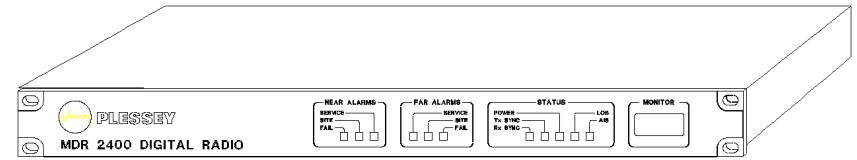

Figure 1. μLink Indoor Unit.

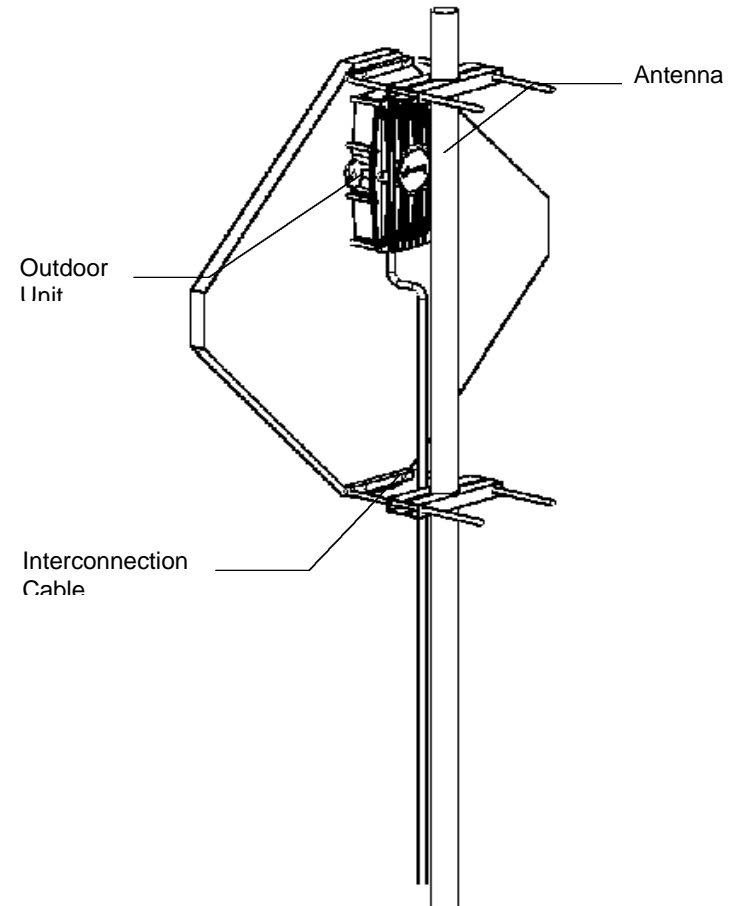

Figure 2. μLink Outdoor Unit and Antenna.

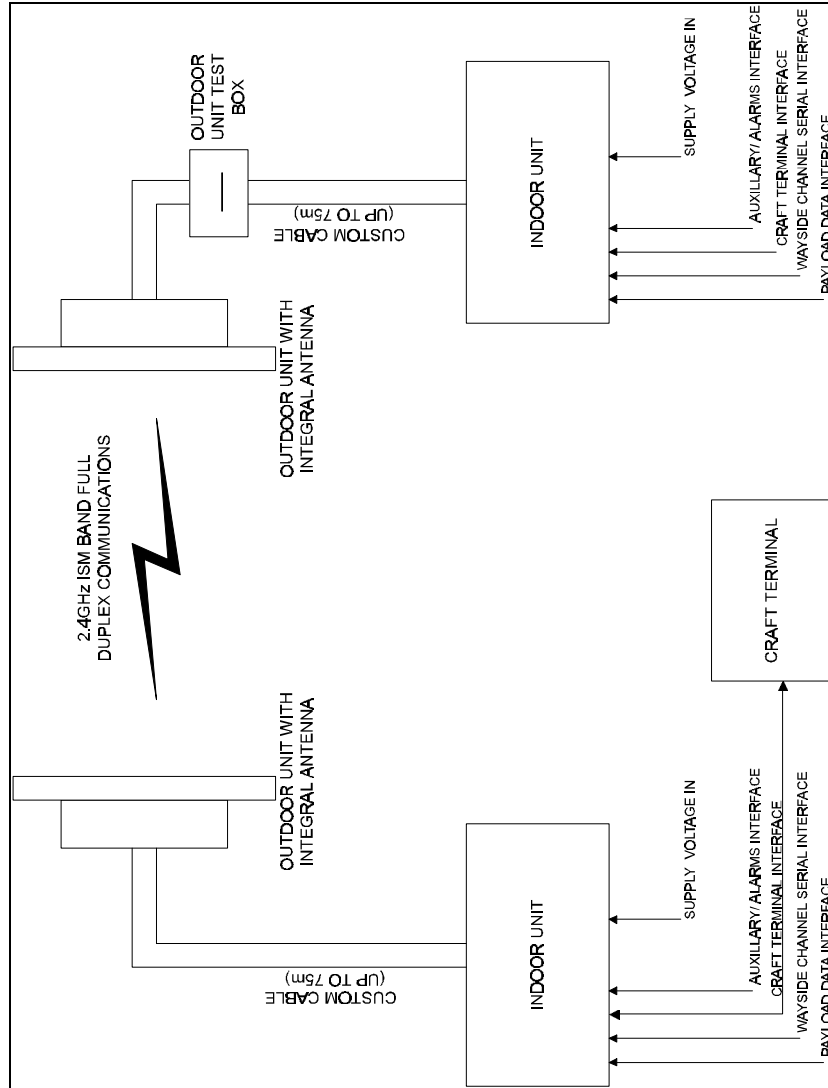

Figure 3. System Overview Block Diagram.



---

**System  
Configuration  
Options**

Table 1 lists the two model variants of the μLink System, with the input data classification and the radio link data rate. Table 2 lists the possible RF configurations with the output power, coupling type, antenna type and regulations with which the unit complies.

---

<b>Model Number</b>	<b>Payload Data Type and Rate</b>	<b>Link Rate</b>	<b>PN Code Length</b>
μLink - E	E1, 2048 kbit/s	2112 kbit/s	11
μLink - T	T1, 1544 kbit/s	2000 kbit/s	13

---

<b>Option</b>	<b>Output Power</b>	<b>Coupling</b>	<b>Antenna</b>	<b>Regulations</b>
μLink – LC	+14 dBm	Custom Non-ohmic	Flat Panel Tx = 8 dBi	ETSI-300-328
μLink – HC	+14 dBm +26 dBm	Custom Non-ohmic	Flat Panel Tx = 18 dBi	FCC-15.247
μLink – D	+10 dBm - +26 dBm	N-type Female	Customer Supplied	FCC-15.247/None

---

**Interface Definitions**

The μLink System has the following user services: (see Table 3).

<b>Table 3. μLink System: User Services</b>	
<b>Payload Data Interfaces</b>	
E1 Data Interface	120Ω RJ-45/75Ω BNC (factory set). Bipolar AMI or HDB3 selectable.
T1 Data Interface	100Ω/75Ω (factory selectable), RJ-45 or BNC Connector. Bipolar AMI or B8ZS selectable.
<b>Wayside Serial Data Channel</b>	
Provided for user data. Supports asynchronous full duplex serial data transfer (with hardware control). 300 to 19200 baud (software selectable).	
<b>Auxiliary / Alarm Inputs and Outputs</b>	
Inputs	Two (2) Switch Closure Sense inputs are provided.
Outputs	Two (2) isolated relay contact outputs are provided. These are presented to the customer as three output, namely <b>Common</b> , <b>NO</b> and <b>NC</b> .

**Planning  
Information****Site Evaluation**

When planning a site for a digital radio relay link, it is of the utmost importance that you take the operational environment of the proposed site into account.

The combined effect of atmospheric environmental factors such as rain and lightning, atmospheric attenuation, signal path obstruction, propagation fading, air temperature gradients, ice build-up, wind and solar radiation can contribute towards reducing the level of performance of the system (as measured in terms of its capability to transfer data without error).

In the higher frequency bands, rainfall is the main attenuation mechanism which limits error performance. Ice and snow will obviously have a similar effect. Severely cold, and excessively warm climatic conditions outside the scope of the operating temperature range can affect the function of the system, especially the outdoor equipment (see *Environmental Characteristics* on page 18 of this manual).

Also, if masts are not sufficiently rigid, very strong winds can affect the antenna beam alignment and outdoor equipment reliability due to wind force build-up and/or vibration in the mast mounted equipment. Non-atmospheric environmental factors such as the electromagnetic interference due to the presence of other antennas, path clutter and terrain topography can also have a detrimental effect on system performance and should be carefully assessed before and during installation.

**Multipath Effects**

Refer to Figure 4. The μLink digital radio operates at a frequency of 2.4 GHz. It is likely that it will be influenced by the effects of multipath. Understanding these effects will help to install the μLink digital radio link and maximise the reliability of the link.

Multipath fade occurs when the receiving antenna receives not only the direct signal from the transmitting antenna but also a signal from the transmitting antenna that has reflected off the ground or nearby obstacles. The reflected signal takes a longer path to reach the receiver and acts as an interferer since it is not in phase with the direct signal. The amplitude of this interferer can be almost equal to that of the direct path, thus degrading the link.

Multipath is dependent on transmit frequency and the specific geometry of the link such as antenna heights, distance between the antennas and the local terrain. To counteract multipath, the installer can change the frequency at which the link operates (a change by 1 channel should be sufficient) or slightly adjust the height of one or both of the antennas ( a change of 0.5m is typical, but this depends on the geometry of the link).

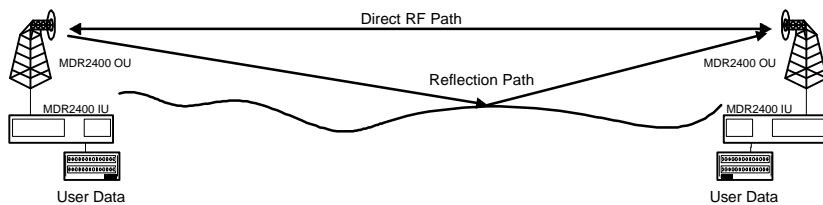

**Figure 4. Multipath Effects.**

**Installation  
Information**

---

**General Information**

This section contains only general information and installation guidelines for the μLink. Specific installation instructions for the Indoor Unit (IU), Outdoor Unit (OU), Antenna and Interconnection Cable are provided in Chapter 2 of this manual.

**Indoor Unit**

The IU is designed for mounting in the DIN 41494 (19") racking standard. It is 1U in height, 390 mm in depth and has a mass of < 6 kg. Optional table-top mounting is possible by fitting rubber feet.

The IUs main data, wayside data, power and alarm interfaces are located on the rear panel, suitable for rack installations. For commissioning and testing, the Monitor connector (used for the Craft Terminal) is located on the IU front panel.

**Outdoor Unit and Antenna**

The OU is fastened to the antenna. The OU / Antenna combination is then mounted to a pole (50 mm to 102 mm in diameter) using mounting brackets. Once installed, this allows for replacement of the OU without the need to realign the antenna.

---

---

**Operational Capabilities**

The user can view equipment status and configuration data of all MDR equipment attached in a multiple hop link from the IU to which the Craft Terminal is attached. The μLink has the following capabilities:

**Upload Indoor Unit Software.** Allows you to transfer a file of executable code from the Craft Terminal to the IU Microprocessor non-volatile memory.

**View Equipment Data.** Allows you to view the following:

- Equipment Status
- Alarms and Alarm History
- Equipment Configuration and Settings
- Data Transmission Performance Characteristics
- Data Channel Options
- Equipment Date and Time

**Control Equipment.** Allows you to configure and/or set system parameters such as; channel selection, RF power level, transmitter on/off, data options, plant alarm options, etc.

**Built-in Testing.** Performs the following built-in tests:

- Start-up BIT (SBIT)
- Continuous BIT (CBIT)
- Initiated BIT (IBIT) - user initiated

**Real Time Clock Interface.** Used to time stamp the command and error log with the current time.

**History Logging.** Logs all CBIT, SBIT commands and responses issued and received by the Indoor Unit.

---

---

**Maintenance Features**

- a. No routine maintenance required.
  - b. Mean time to repair after arrival on site is less than 30 minutes, provided that the units to be repaired are reasonably accessible.
  - c. Extensive self-diagnostics with software-based fault localisation.
  - d. Craft Terminal diagnostics, control and management functions are able to access any local or remote station equipment linked by radio.
  - e. IU alarm display allows for simple fault diagnostics.
  - f. IU common to all OUs.
  - g. All panels and covers can be removed with one tool.
  - h. No special external test equipment is required to maintain the system.
  - i. OU can be replaced without having to re-align the antenna.
- 

**Built-in Test Features**

The μLink has the following built-in test features:

- LED alarm and status indicators on IU Front Panel.
  - Remote unit alarms indicated similar to the local unit's alarms.
  - Historic alarm logging (last 1000 events).
  - CRC-4 error detection on user data.
  - Loss of Data Input Detection.
  - Loss of Frame Detection on Radio Frames.
  - Automatic AIS Insertion.
  - Input Data Loopback.
  - Output Data Loopback.
  - Payload data Output Enable/Disable function.
  - Real Time Clock for time-stamping of alarm and other events (Y2K compatible).
-

**System Specifications**

The μLink has the following specifications:

**Performance Characteristics**

**Link Range:**

**Low power Coupler type.** Up to 10 km. Provides a link margin of 18 dB based on a  $10E^{-5}$  BER for an E1 link.

**High Power Coupler type.** Up to 30km using a 18 dBi Tx/Rx antenna. Provides a link margin of 22 dB based on a  $10E^{-5}$  BER for an E1 link.

**High Power Diplexer type.** Up to 50 km using a 24 dBi antenna. Provides a link margin of 23 dB based on a  $10E^{-5}$  BER for an E1 link.

**System Start-up Time.** Less than ten (10) seconds (at 25 °C). If ambient temperature is < -15 °C, it takes 10 mins. before system operates to full specification.

**Data Transmission Characteristics**

Description	Characteristics
a. Frequency Band	2.400 GHz to 2.4835 GHz
b. Go/Return spacing	42 MHz (E1, T1)
c. Data Rate Options	2048, 1544 (T1) kbit/s.
d. Interface Standards	ITU-T G.703, G.704, G.706, G.823
e. Jitter and Wander	ITU-T G.823
f. Modulation	QPSK
g. Error Detection Code	CRC-4
h. Background BER	< $10^{-11}$



**Transmitter  
Characteristics**

---

<b>Description</b>	<b>Characteristic</b>
a. Carrier Frequency Band	2.400 to 2.442 GHz (LB) 2.442 to 2.4835 GHz (HB)
b. Modulation B/width (max)	23.5 MHz
c. Link Data Rate (max)	2142 kbit/s
d. Tx Power, max. oper.	+24 dBm (-C) +26 dBm (-D)
e. Tx Power, min. oper.	+10 dBm (All options)
f. Frequency Stability	$\pm 7$ ppm
g. Tuning method	Microprocessor- controlled PLLs
h. Transmitter disable under software control	
i. Modulation disable under software control	
j. Spurious Emissions comply fully with FCC 15.247, FCC 15.201 and ETSI 300-328	

---

**Receiver  
Characteristics**

<b>Description</b>
a. Sensitivity measured at radio module input connector (typical): <b>Data Rate (kbit/s)</b> <b>BER=<math>10^{-6}</math> (dBm)</b> 2048                          -90
b. Spurious Response Rejection complies with ETS 300-328
c. Spurious Emissions-see <i>Transmitter Characteristics</i>
d. Equipment Background BER < $10^{-11}$ (Receive level between 9 and 34 dB above threshold).

---

---

**Wayside Service Channel**

**Description**

- One (1) wayside service channel of RS-232 serial data up to a baud rate of 19200 is provided.
- The serial data channel provides simultaneous, full duplex serial data transfer between stations. Data rates range from 300 to 19200 baud. The RS-232 standard is provided, with the following signals : TxD, RxD and Signal Ground.
- The interface provides a DCE (Data Communications Equipment) interface mode.

---

**Auxiliary/Alarm Interfaces**

**Description**

- a. Two (2) inputs (for sensing contact closure or opening) are provided to sense site alarm inputs. The states of these alarm inputs are accessible from connected management equipment, as well as from the IU Front Panel.
  - b. Two (2) relay contact outputs, normally open (N.O.) and normally closed (N.C.) contacts, are provided as alarm / auxiliary outputs. Output states are software customised and controlled. The outputs are used to indicate alarm or other states selected by the operator.
-

---

**Power Supply  
Characteristics****Description**

- a. Input supply voltage (DC) 21.5 to 56 VDC
  - b. Input supply voltage (AC) 100 to 240 VAC
  - c. Power Consumption < 20 W
  - d. Selection of a single DC supply or an AC supply to the IU. The OU is supplied by an isolated single DC supply fed from the IU via the interconnecting cable.
  - e. Reverse voltage protection for equipment and supply (DC option only).
- 

**Controls and  
Displays****Description**

- a. The μLink IU has an LED *alarm* and *status* display. All control functions are accessed via the Craft Terminal.
  - b. The operator can perform all essential control and management functions of both the near and far end station equipment in the link using the Craft Terminal.
-

**Antenna Characteristics (μLink -C)**

---

Description	Characteristic
a. Size	550mm x 550mm x 25mm flat panel
b. Frequency	2.400 GHz to 2.4835 GHz
c. Gain Tx / Rx	18 dBi ± 0.2 dB / 18 dBi ± 0.4 dB
d. Connection	non-ohmic coupling to the OU
e. VSWR	< 1.5 : 1
f. Isolation Tx/Rx	> 40 dB
g. Polarisation	Tx / Rx Orthogonal

---

The μLink -D type can use antennas from other manufacturers. Refer to the setup procedures on page 27 to determine the transmitter power level settings required for different antenna gains. The following antennas have been tested with the -D type OU and conform to the FCC requirements.

**Antenna Types (μLink -D)**

---

Description	Characteristic	
Cushcraft Part No. PC2415N	Frequency	2.400 GHz to 2.4835 GHz
	Gain	17dBi
	Transmitter	Set to 7 (26dBm)
	Construction	15 Element Yagi
California Amplifier Part No. 130094-1	Frequency	2.400 GHz to 2.4835 GHz
	Gain	24dBi
	Transmitter	Set to 5 (24dBm)
	Construction	Grid Parabolic

---

---

**Equipment Status  
Monitoring****Description**

- a. **Indoor Unit Status.** The IU monitors the state of the baseband signals in the Information Base and informs the State and Mode Control function of any problems or failures.
  - b. **Outdoor Unit Status.** The OU transmits a periodic status message to the IU containing the status of the OU. The Fault and Status Manager in the IU monitors this, updates the Information Base and informs the State and Mode Control function of any problems.
  - c. **Far-end Radio Station Status.** The near end IU transmits a periodic status message to the remote IU. The Fault and Status Manager in the remote IU determines if the transmitting IU is functioning normally then updates the Information Base and informs the State and Mode Control function of any problems.
  - d. **Health Monitoring.** A background process continuously checks the health of the system hardware and software and reports any anomalies to the Management Information Base (MIB). The Fault Manager responds to this information.
-

**Mechanical  
Characteristics**

---

<b>Description</b>	<b>Characteristic</b>
a. Mass	
OU (no antenna)	< 4 kg
IU	< 6 kg
b. IU Racking	19" DIN 41494, 1U
Standard	
c. OU Mounting	Pole mount brackets.
Standard	50 to 102 mm pole diameter.

---

**Environmental  
Characteristics**

---

<b>Description</b>	<b>Characteristic</b>
a. Temp. Range	
• Indoor Unit	0 to +50°C (operating) -40 to +70°C (survival)
• Outdoor Unit	-20 to +70°C (operating) -40 to +70°C (survival)
b. Humidity	
• Indoor Unit	5 to >90% (weather protected locations)
• Outdoor Unit	8 to 100% (all weather)
c. Wind Speed (Outdoor Equipment)	up to 160 km/h (functional)
d. Operating Atmospheric Pressure	0.7 to 1.06 kPa
e. Lightning Protection	ITU-T K.20 for: PSU, Payload Data and Interconnection Cable

---

---

**Frequency Band Plan**

Refer to Figure 5. The μLink Digital Radio operates in the 2.4 GHz to 2.4835 GHz ISM frequency band. The μLink has predefined channels allocated within this band (Channels A and B). The recommended channel spacing between transmit and receive frequencies is 42 MHz. This is based on the bandwidth occupied by the spread spectrum signal and is used to maximise link performance.

---

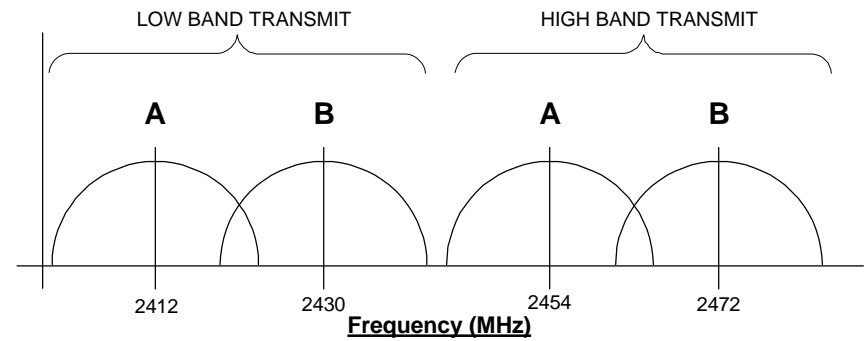

The recommended frequency pairs for the channel plan are :  
A : 2412 & 2454 MHz  
B : 2430 & 2472 MHz

**Figure 5. Frequency Band Plan.**

**This page intentionally left blank**



## Chapter 2: Installation

---

### Introduction to Chapter 2

Chapter 2 provides the installation personnel with the information required to assemble, install and commission the μLink System.

---

### Site Requirements

Before installing the μLink, ensure that the installation site meets the following requirements:

- Site characteristics are satisfactory (see *Planning Information* on page 7).
- Suitable mast (pole) used for Antenna and Outdoor Unit (OU) installation is firmly in position. Pole diameter may be between 50 and 102 mm.



**CAUTION**  
**THE POLE AND THE EQUIPMENT ROOM, WHICH HOUSES THE INDOOR UNIT (IU) MUST BE EARTHED FOR LIGHTNING PROTECTION ACCORDING TO STANDARD LOCAL PRACTICES.**

---

**Parts and Accessories Supplied for Installation**

The following parts and accessories are supplied by Tellumat for the installation of the µLink System. Note that this list relates to the parts supplied for a system at a DRS, ie. one end of a DRL.

Description	Qty	Remarks
Antenna	1	The antenna is shipped with a complete installation kit including O-rings, mounting brackets, nuts and bolts etc.
Outdoor Unit (OU)	1	Ensure OU is compatible with the antenna provided.  If the customer is using his own Antenna, the OU will be delivered pre-mounted on a pole adaptor plate.
Indoor Unit (IU)	1	
Data Interface Card	1	E1 or T1.
Interconnection Cable	1	10 m, 20 m, 50 m or 75 m in length as ordered. Used to connect the IU to the OU.

**Customer  
Furnished Tools  
and Equipment**

The following table lists all tools and equipment required to install the μLink System. Note that these items must be supplied by the customer

<b>Description</b>	<b>Qty</b>	<b>Remarks</b>
13 mm Spanner	1	Used to secure the Antenna to the Pole.
8 mm Spanner	1	Used to secure the Antenna Mounting Bracket to the Antenna.
Large Flat Screwdriver	1	As above.
Earth Cable or Strap with 5 mm earth lug	1	For earthing the IU. Braided tube, copper tinned. Gauge 4 mm CSA. 8 x 1 mm thick, 45 A, 24/12/0,16.
Cable Ties	A/R	Used to secure the cable to the mast at regular intervals.
AC Supply Cable	1	Standard 3-pin IEC AC plug. For AC supply connection to the rear panel of the IU.
OR	OR	
DC Supply Cable	1	Minimum 2.5 mm square conductor, rated for 10 A. For connection between the power supply and the IU DC connector on the rear panel.
Binoculars (optional)	1	Used for locating the far end site. This will assist in the antenna alignment operation.

**Installation Overview**

Installation of the μLink is described under the following four main headings:

- a. Installing the Outdoor Unit (OU) and Integral Antenna.
- b. Installing the Indoor Unit (IU).
- c. Installing the IU/OU Interconnection Cable.
- d. System Commissioning.

To supplement the installation procedure, the following appendix is provided at the end of this chapter:

- Appendix A provides connector pin details for the external connectors of the IU and OUs.

**Antenna Installation**

Follow these general steps to install the Antenna. Refer to the Antenna Manufacturer’s installation instructions for specific types of antennas.

Step	Action
1.	Secure the C-shaped mounting bracket to the Antenna using the two securing screws and bolts (see Figure 6).
2.	Position the antenna in the required position on the pole. Note the orientation of the antenna.
3.	Secure the antenna to the pole by tightening the mounting bracket securing nuts (two nuts on either end of the pole clamp).

	<p><b>CAUTION</b>  <b>ENSURE THAT THE POLE IS EARTHED FOR LIGHTNING PROTECTION ACCORDING TO STANDARD LOCAL PRACTICES.</b></p>
---	---

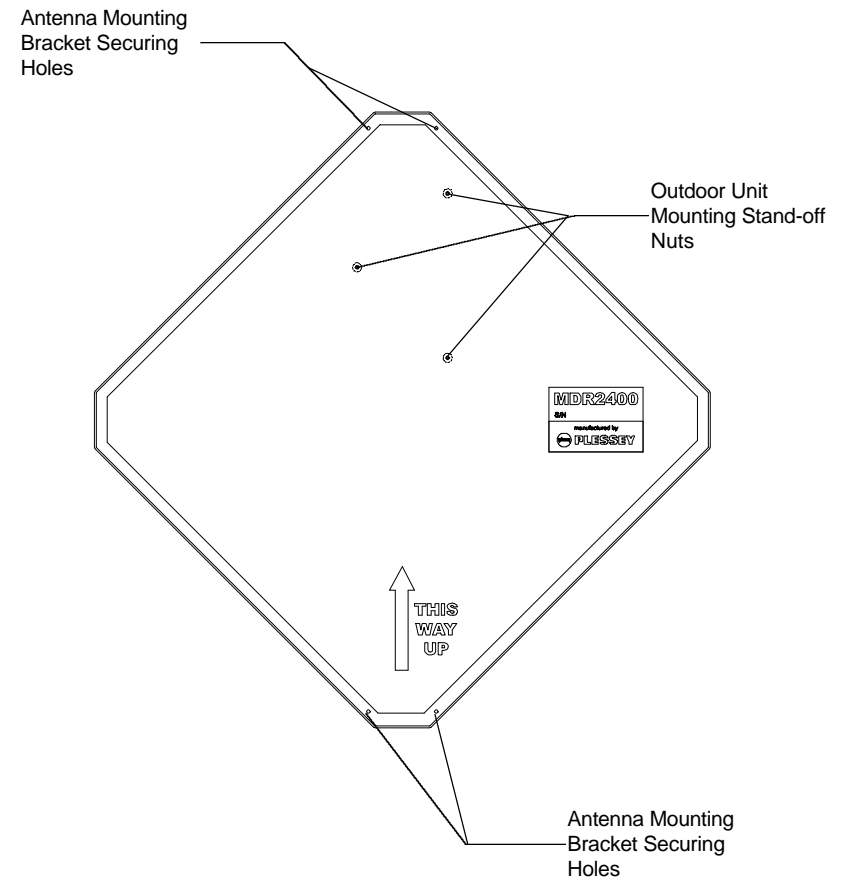

Figure 6. μLink -C Antenna.

**Outdoor Unit  
Installation**

Follow these steps to mount the OU onto the Antenna.  
See Figure 6 and Figure 7.

Step	Action
1.	Loosen the three OU securing stand-off nuts located on the Antenna (see Figure 6).
2.	Position the OU on the stand-off nuts through the three (3) key hole slots on the OU (see Figure 7).
3.	Tighten the securing stand-off nuts.

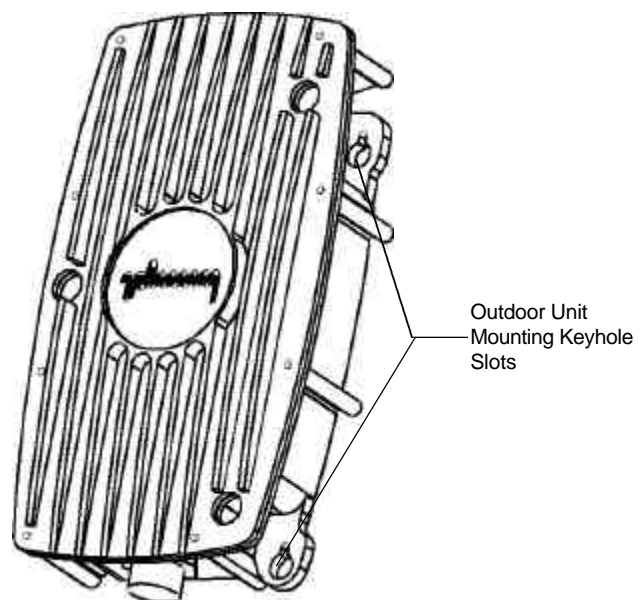

Figure 7. μLink Outdoor Unit.

**Outdoor Unit  
Power Levels**

Follow these steps to set the transmitter power level on the OU. Refer to table 4 for transmitter power levels.

Step	Action
1.	Determine the gain of the antenna, $A_T$ , to be installed with the OU.
2.	Calculate the transmitter power, $P_T$ , according to the following formula:  $P_T = 30\text{dBm} - (A_T - 6)/3 \text{ dBm}$
3.	Determine the power level to be used in NMS by consulting table 4.
4.	Install a fixed attenuator between the OU and the antenna if the power level can not be sufficiently reduced.
5.	Set the transmitter power level in NMS.
6.	Repeat for both stations.

<b>Example: Determining the transmitted power level.</b>	
Step	Action
1.	Install a 24dBi antenna.
2.	Transmitter power level to be used is:  $P_T = 30 \text{ dBm} - (24-6)/3 \text{ dBm}$ $= 30 \text{ dBm} - 6 \text{ dBm}$ $= 24 \text{ dBm}$
3.	Power level 5 corresponds to 24 dBm transmitter power (from table 4).
4.	Set the power level to level 5 in NMS.

<b>NMS Power Level Setting</b>	<b>Transmitter Power (dBm)</b>
1	20
2	21
3	22
4	23
5	24
6	25
7	26

---



**WARNING-** To comply with FCC RF exposure limits, the antennas for this transmitter must be fixed-mounted to provide a separation distance of 1 meter (3.5 ft) or more from all persons to satisfy RF exposure requirements.

---



**Indoor Unit  
Installation**

Follow these steps to install the IU. See Figure 8.

<b>Step</b>	<b>Action</b>
5.	Install the Data Interface module into the IU by sliding it in until the male connector on the module mates firmly with the female connector inside the IU.
6.	Secure the Data Interface module to the IU with the two (2) x M4 screws provided.
7.	Slide the IU into the 19" rack and secure to the rack using four (4) x M3 screws. Note that if the unit is to be table mounted, first fit the four (4) x rubber feet to each corner on the base of the IU.
8.	Earth the IU by connecting the earth cable or strap between the station earth and the earth stud on the IU rear panel.
9.	Observing the polarity of the supply, wire up the supplied power connector cable plug and connect it to the facility DC supply (21 to 56 V) through a minimum 10 A circuit breaker. Secure the connector screws to the unit. Check the supply voltage using the Multimeter. OR Connect the AC power cable from the station power source to the AC power connector on the rear panel of the IU.

Step	Action
10.	Make-off the 120Ω (E1)/100Ω (T1) - factory set tributary input and output connections and connect to the RJ-45 connector on the rear panel of the IU. Alternatively, connect the 75Ω (factory set) coaxial tributary connections to the BNC input and output connectors on the IU rear panel as required. See Appendix A at the end of this chapter for the pin details of the relevant tributary connector type. Ensure that all unused tributaries are disabled.
11.	Connect the 15-pin D-type Auxiliary I/O Connector (alarm interfaces) on the rear panel of the IU to the appropriate Krone block or other distribution rack (for further connection to appropriate supervisory equipment as required). See Appendix A at the end of this chapter for pin details.
12.	Connect the Serial Data interface cable to the Wayside connector on the IU rear panel.

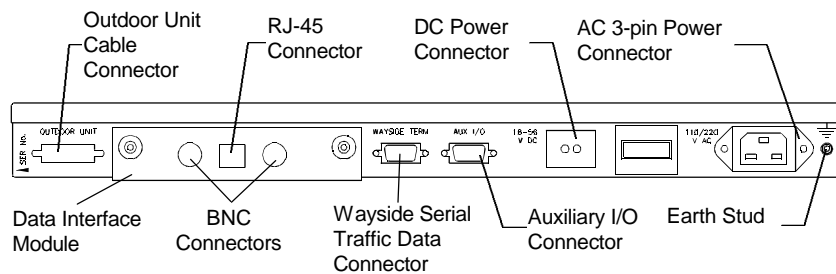

Figure 8. Indoor Unit Rear Panel.

**Interconnection  
Cable Installation**

Follow these steps to install the IU / OU interconnection cable.

**CAUTIONS**

**DO NOT EXCEED THE RECOMMENDED BENDING RADIUS OF THE CABLE, IE. 10 cm.**

**DO NOT OVER TIGHTEN THE CABLE STRAPS ON THE CABLE AND DO NOT FASTEN THE ACTUAL STRAP LOCKING MECHANISM OF THE CABLE STRAP ONTO THE CABLE.**

<b>Step</b>	<b>Action</b>
1.	Connect the interconnection cable to the connector on the base of the Outdoor Unit (see Figure 9).
2.	Using cable ties or straps, secure the cable to the pole at regular intervals.
3.	Connect the other end of the interconnection cable to the Outdoor Unit connector on the IU rear panel (see Figure 8).
4.	Tighten the Outdoor Unit connector securing screws on the IU rear panel.

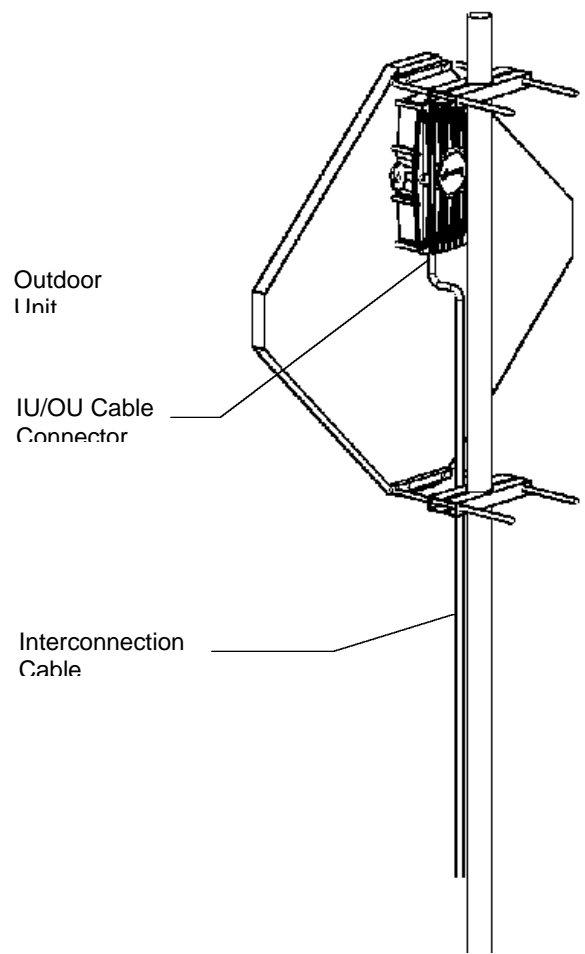

Figure 9. Outdoor Unit Mounted on Antenna.

---

**System  
Commissioning**

After completing the physical installation of the Indoor Unit, Antenna and Outdoor Unit, and the Interconnection Cable, you need to commission the System. This procedure describes how to set up the minimum requirements for successful μLink System operation.

---

**Information  
Required**

Before commissioning the system, you should know the proposed frequency band plan (Tx and Rx) for each station, and the PN sequence for the link.

---

**Commissioning  
Procedure*****Setting-up Procedure***

Perform the following steps at both stations:

- Locate the far site and point the antenna to the antenna at the far site, as accurately as possible.
- Switch the IU power ON.
- Install and Access the μLink Management Software (refer to Chapter 4 of this manual).
- Configure the radio channel as required.
- Configure the Tx and Rx PN sequences.
- Set the Tx power to maximum.

***Beaming-up***

1. Check the RSSI and BER levels.
2. Align the antenna until the Maximum RSSI and minimum BER levels are attained.

***Set Critical Parameters***

1. Reduce the Tx power until an RSSI of between -65 and -70 dBm is obtained. This is important to avoid interference to co-located systems.
-

---

**Link Error  
Performance Test**

Perform a link error performance test as follows:

1. Run data over the link for a period of 15 hours.
2. Record the RSSI
3. Record the BER
4. Record the LED statuses

Record all results on a check list. See Table 5 for an example.

---

	<b>Description</b>	<b>Setting/Remarks</b>
1.	Transmit Frequency/Channel	
2.	Final RSSI	
3.	Link Test BER	
4.	LED Status	

## Appendix A to Chapter 2:

### μLink External Connector Pin Details

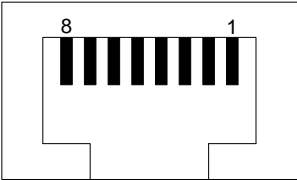
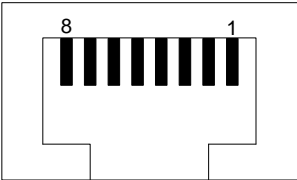
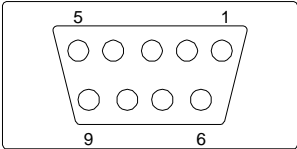
<b>Indoor Unit Connector Pin Details</b>		
<p><b><u>E1 DATA (IU Rear Panel)</u></b>  <b>8-pin RJ-45 Female Connector</b></p>		
	<b>Pin</b>	<b>Details</b>
	1	E1 Tx Data (+)
	2	E1 Tx Data (-)
	3	E1 Rx Data (+)
	6	E1 Rx Data (-)
		4, 5, 7, 8      Not Used
<p><b><u>T1 DATA (IU Rear Panel)</u></b>  <b>8-pin RJ-45 Female Connector</b></p>		
	<b>Pin</b>	<b>Details</b>
	1	T1 Tx Data (+)
	2	T1 Tx Data (-)
	3	T1 Rx Data (+)
	6	T1 Rx Data (-)
		4, 5, 7, 8      Not Used
<p><b><u>WAYSIDE TERM (IU Rear Panel)</u></b>  <b>9-pin D-type Female Connector</b></p>		
	<b>Pin</b>	<b>Details</b>
	2	Tx
	3	Rx
	5	Ground

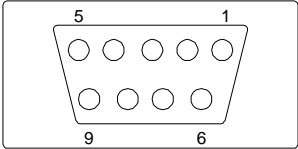
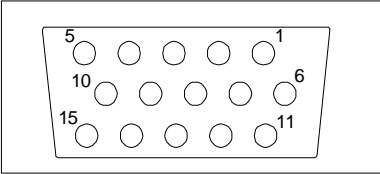
<b>Indoor Unit Connector Pin Details</b>		
<p><b><u>MONITOR</u> (IU Front Panel)</b>  <b>9-pin D-type Female Connector</b></p>		
	<p><b>Pin</b></p>	<p><b>Details</b></p>
	2	Tx
	3	Rx
	5	Ground
	1, 4, 6, 7, 8, 9	Not Used
<p><b><u>AUX I/O</u> (IU Rear Panel)</b>  <b>15-pin High Density D-type Female Connector</b></p>		
	<p><b>Pin</b></p>	<p><b>Details</b></p>
	1	Relay 1 Common
	2	Relay 1 N.O
	3	Relay 1 N.O
	4	Relay 1 N.C
	5	Relay 1 N.C
	6	Relay 1 Common
	7	Relay 2 Common
	8	Relay 2 Common
	9	Relay 2 N.O
	10	Relay 2 N.O
	11	Relay 2 N.C
	12	TTL Input 1
	13	TTL Input 1 Return
	14	TTL Input 2
	15	TTL Input 2 Return

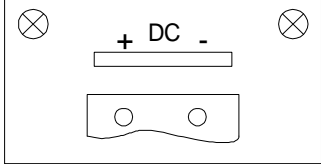
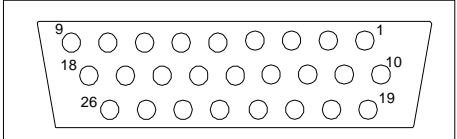

<b>Indoor Unit Connector Pin Details</b>		
<p><b>DC (IU Rear Panel)</b>  <b>2-pin Wieland Polarised 8213 Type</b></p> 	<p><b>Pin</b></p> <p>+</p> <p>-</p>	<p><b>Description</b></p> <p>Positive</p> <p>Negative</p>
<p><b>OUTDOOR UNIT (IU Rear Panel)</b>  <b>26-pin High Density D-type Female Connector</b></p> 		
	<p><b>Pin</b></p> <p>1</p> <p>2</p> <p>3</p> <p>4</p> <p>5</p> <p>6</p> <p>7</p> <p>8</p> <p>9</p> <p>10</p> <p>11</p> <p>12</p> <p>13</p> <p>14</p> <p>15</p> <p>16</p> <p>17</p> <p>18</p> <p>19</p> <p>20</p> <p>21 - 25</p>	<p><b>Details</b></p> <p>Tx Data +</p> <p>Tx Data -</p> <p>Rx Data GND</p> <p>Tx Clk +</p> <p>Tx Clk -</p> <p>Tx Clk GND</p> <p>Rx Data +</p> <p>Rx Data -</p> <p>Rx Data GND</p> <p>Rx Clk +</p> <p>Rx Clk -</p> <p>Rx Clk GND</p> <p>Rx Cntrl +</p> <p>Rx Cntrl -</p> <p>Rx Cntrl GND</p> <p>Tx Cntrl +</p> <p>Tx Cntrl -</p> <p>Tx Cntrl GND</p> <p>+Vsupply</p> <p>+Vsupply</p> <p>GND</p>

<b>Outdoor Unit Connector Pin Details</b>																																																							
<b><u>CABLE CONNECTOR (OU Base)</u></b>																																																							
	<table border="0"> <thead> <tr> <th><b>Pin</b></th> <th><b>Details</b></th> </tr> </thead> <tbody> <tr><td>A</td><td>24V</td></tr> <tr><td>B</td><td>24V</td></tr> <tr><td>C</td><td>TXC-</td></tr> <tr><td>D</td><td>TXC+</td></tr> <tr><td>E</td><td>TXDCLK-</td></tr> <tr><td>F</td><td>RXDCLK+</td></tr> <tr><td>G</td><td>TXDCLK+</td></tr> <tr><td>H</td><td>N/C</td></tr> <tr><td>J</td><td>RXDCLK+</td></tr> <tr><td>K</td><td>RXD+</td></tr> <tr><td>L</td><td>RXC-</td></tr> <tr><td>M</td><td>RXD-</td></tr> <tr><td>N</td><td>RXC+</td></tr> <tr><td>P</td><td>TXD-</td></tr> <tr><td>R</td><td>TXD+</td></tr> <tr><td>S</td><td>GND</td></tr> <tr><td>T</td><td>GND</td></tr> <tr><td>U</td><td>GND</td></tr> <tr><td>V</td><td>GND</td></tr> <tr><td>W</td><td>GND</td></tr> <tr><td>X</td><td>GND</td></tr> <tr><td>Y</td><td>GND</td></tr> <tr><td>Z</td><td>GND</td></tr> <tr><td>a</td><td>GND</td></tr> <tr><td>b</td><td>GND</td></tr> <tr><td>c</td><td>GND</td></tr> </tbody> </table>	<b>Pin</b>	<b>Details</b>	A	24V	B	24V	C	TXC-	D	TXC+	E	TXDCLK-	F	RXDCLK+	G	TXDCLK+	H	N/C	J	RXDCLK+	K	RXD+	L	RXC-	M	RXD-	N	RXC+	P	TXD-	R	TXD+	S	GND	T	GND	U	GND	V	GND	W	GND	X	GND	Y	GND	Z	GND	a	GND	b	GND	c	GND
<b>Pin</b>	<b>Details</b>																																																						
A	24V																																																						
B	24V																																																						
C	TXC-																																																						
D	TXC+																																																						
E	TXDCLK-																																																						
F	RXDCLK+																																																						
G	TXDCLK+																																																						
H	N/C																																																						
J	RXDCLK+																																																						
K	RXD+																																																						
L	RXC-																																																						
M	RXD-																																																						
N	RXC+																																																						
P	TXD-																																																						
R	TXD+																																																						
S	GND																																																						
T	GND																																																						
U	GND																																																						
V	GND																																																						
W	GND																																																						
X	GND																																																						
Y	GND																																																						
Z	GND																																																						
a	GND																																																						
b	GND																																																						
c	GND																																																						

## Chapter 3: Operational Information

---

### **Introduction to Chapter 3**

Chapter 3 provides the user with a description and the location of all controls, indicators and connectors located on the front and rear panels of the μLink Indoor Unit (IU).

---

### **Indoor Unit (IU) Controls, Indicators and Connectors**

#### ***Front Panel***

Figure 10 shows all items on the IU Front Panel. Table 6 describes the items shown in the illustration.

---

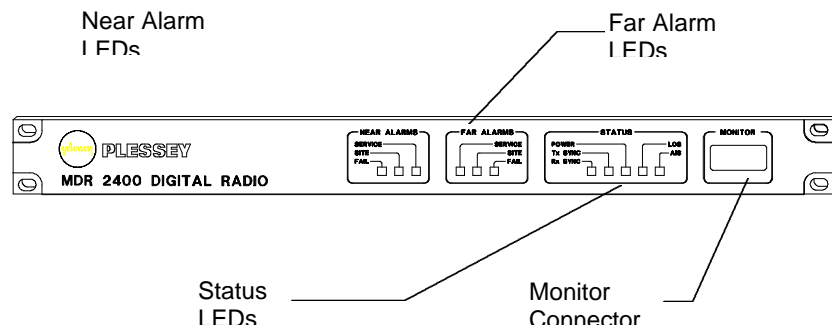

Figure 10. IU Front Panel Controls, Indicators and Connectors.

<b>Table 6. IU Front Panel: Controls, Indicators and Connectors</b>	
<b>Item</b>	<b>Description</b>
Near Alarm LEDs	Used to indicate <b>Failure</b> , <b>Service</b> and <b>Site</b> alarms or status. The LEDs are tri-colour to indicate <b>No Alarm</b> (Green), <b>Existing Alarm</b> (Red) and <b>Historic Alarm</b> (Amber) conditions. Refer to Chapter 5, Maintenance Information for more details about these alarms.
Far Alarm LEDs	As for Near Alarm LEDs.
Status LEDs	<p>The following status LEDs are located on the IU Front Panel:</p> <ul style="list-style-type: none"> <li>a. <b>Power ON</b></li> <li>b. <b>Tx Sync</b></li> <li>c. <b>Rx Sync</b></li> <li>d. <b>Loss of Signal (LOS)</b></li> <li>e. <b>Alarm Indication Signal (AIS)</b></li> </ul> <p>The <b>Power-ON</b> LED is red. If LED is ON, it indicates <b>Power-ON</b> if OFF, it indicates Power Off. LEDs b to e are tri-coloured to indicate <b>No Fault</b> (Green), <b>Existing Fault</b> (Red) and <b>Historic Fault</b> (Amber) conditions. Refer to Table 7 for more information about the Status LEDs.</p>
Monitor Connector	RS-232 standard 9-pin D-type connector for operation at a nominal 19200 baud. For use with the Craft Terminal.

<b>Table 7. Status LEDs:</b>		
<b>LED</b>	<b>Status</b>	<b>Remarks</b>
Power On	Off	Power Off
	Red	Power On
Tx Sync	Green	Tx Data Framelock
	Red	Loss of Tx Data Framelock
	Amber	Historic Tx Sync Framelock Loss
Rx Sync	Green	Rx Data Framelock
	Red	Loss of Rx Data Framelock
	Amber	Historic Rx Sync Framelock Loss
LOS	Green	Tx Data Present
	Red	No Tx Data Detected
	Amber	Historic LOS
AIS	Green	AIS Not Present
	Red	AIS Present
	Amber	Historic AIS

**Indoor Unit (IU)  
Controls,  
Indicators and  
Connectors**

**Rear Panel**

Figure 11 shows all items on the IU Rear Panel.  
Table 8 describes the items shown in the illustration.

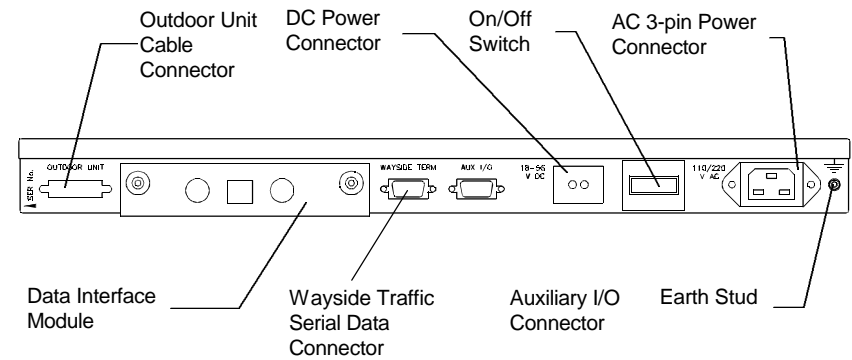

**Figure 11. IU Rear Panel Controls, Indicators and Connectors.**

---

<b>Table 8. IU Rear Panel: Controls, Indicators and Connectors</b>	
<b>Item</b>	<b>Description</b>
Outdoor Unit Cable Connector	26-pin, High Density D-type female connector for IU/OU interconnection cable.
Wayside Traffic Serial Data Connector	9-pin D-type female connector. Used for Wayside traffic channels.
DC Power Connector	Weiland 2-way chassis mounted connector.
Auxiliary I/O Connector	15-pin, High Density D-type female connector. Used mainly for diagnostics and maintenance purposes. Divided into two main sections: <ul style="list-style-type: none"> <li>• Plant Alarm Inputs</li> <li>• Equipment Control Relay Outputs.</li> </ul>
On/Off Switch	Power switch to switch the IU On or Off.
AC 3-pin Power Connector	Chassis mounted IEC AC Inlet. Accepts 100 VAC to 240 VAC.
Earth Stud	Screw type terminal for earth connection.
Payload Data Interface Connector	The connector types depend on the type of Data Interface module installed. Available options are: <b>E1</b> (120Ω/75Ω RJ-45/BNC), <b>T1</b> (100Ω/75Ω RJ-45/BNC).

---



## Chapter 4: μLink Management System

---

### General Information

The μLink Management Information System is a software tool for the management (installation, maintenance and support) of μLink digital radio links.

The software runs on an IBM compatible PC running Windows 95 (user supplied), connected to the Indoor Unit (IU) via a serial communications interface.

It provides extensive management functions on site and, via the microwave radio link, can be used to access any μLink station within a link domain.

---

### Hardware (supplied by Customer)

The hardware may be supplied by the customer. It is typically a laptop or notebook computer, and must have the following minimum characteristics:

- IBM PC compatible.
  - 486 processor, 25 MHz clock speed.
  - 16 Mbyte RAM
  - 120 Mbyte hard drive with Windows 95 installed.
  - 1.44 Mbyte floppy drive.
  - Mouse or other pointing device.
  - 1 x RS-232 serial port (Com port). This is in addition to the Com port that may be used by the mouse.
  - SVGA monitor (minimum screen resolution of 640 x 480).
-

**Software and Hardware (supplied by Tellumat)**

The software is the operator interface to the operation and control of the µLink System. It allows you to perform tasks such as; system configuration, controlling system parameters and accessing on-line help.

It is supplied by Tellumat on one 1.44 Mbyte, 3.5 inch stiffer diskette. It is supplied as executable code, supported with installation and other supplementary files.

In addition to the software, Tellumat also supplies an RS232 interconnection cable for use between the IU and the PC interface. Refer to Appendix A at the end of Chapter 2 in this manual for pin details of this cable interface (Monitor connector).

**Setting-up**

Follow these steps to set up the µLink Management Information System for use with the µLink:

Step	Action
1.	Connect the supplied interface cable between the RS-232 port on the rear of the computer, to the Monitor connector on the front panel of the Indoor Unit.
2.	Switch the computer On.
3.	Run the Windows operating system.
4.	Insert the application Software disk into the appropriate disk drive (A or B).
5.	In Windows 95, access the Control Panel and select the Add/Remove Programs. From the Install/Uninstall folder, select the Install button.

Step	Action
6.	Insert the installation disk of the software into the relevant drive (A or B) of the PC and then select <b>Next</b> . Run <b>*\Setup.exe</b> by selecting <b>Finish</b> (* being the drive identifier).
7.	Follow the screen prompts to install the software onto the hard drive of the computer.

---

#### Accessing the Software Program

After installing the software, open the program by selecting the μLink option from the Program Group in the Start Menu.

---

#### Menu Structure

The μLink Management Information Software is a menu driven program that provides you with a graphical interface of the μLink Station or Network. This interface allows you to select various options to configure, manage and interrogate the μLink System.

After accessing the software program, the Main Screen is displayed (see Figure 12).

---

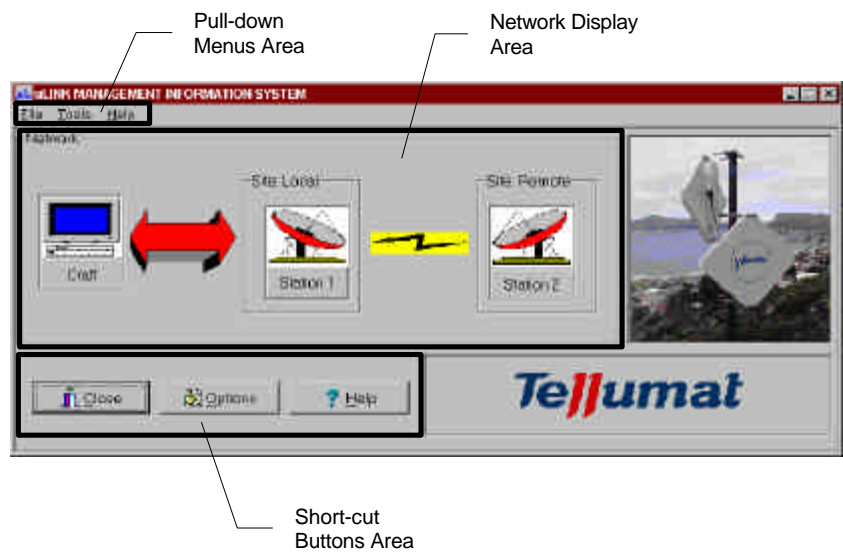

Figure 12. μLink Management Software: Typical Main Screen.

---

**Main Screen**

The Main Screen has the following three main functional areas:

- Pull-down Menus Area (see page 49)
  - Short-cut Buttons Area (see page 49)
  - Network Display Area (see page 50)
-

---

**Pull-down Menus Area**

The following pull-down menus are available from the Main Screen:

- File.** This menu provides you with an exit option, which allows you to exit from the μLink Management Software.
- Tools.** This menu provides the following options:
- **Options.** This option allows you to select the μLink Management Software terminal serial port. You can select No Port, COM1, COM2, COM3 or COM4.
  - **Local IU/Remote IU.** These options allows you to view the details of the selected site.
- Help.** This menu provides you with various help facilities.
- 

**Short-cut Buttons Area**

The following short-cut buttons are provided:

- Close.** Allows you to exit from the μLink Management Information System.
- Options.** As for Tools/Options (see *Pull-down Menus Area*).
- Help.** As for Help/About (see *Pull-down Menus Area*).
-

**Network Display Area**

The Network Display Area of the Main Screen provides a graphical display showing all the microwave links in the domain.

It provides the local and remote site station names and shows you the site to which the μLink Management Software is connected.

To view the details of a particular site, simply click on the required site. The Station Control screen for the selected site is displayed (see Figure 13).

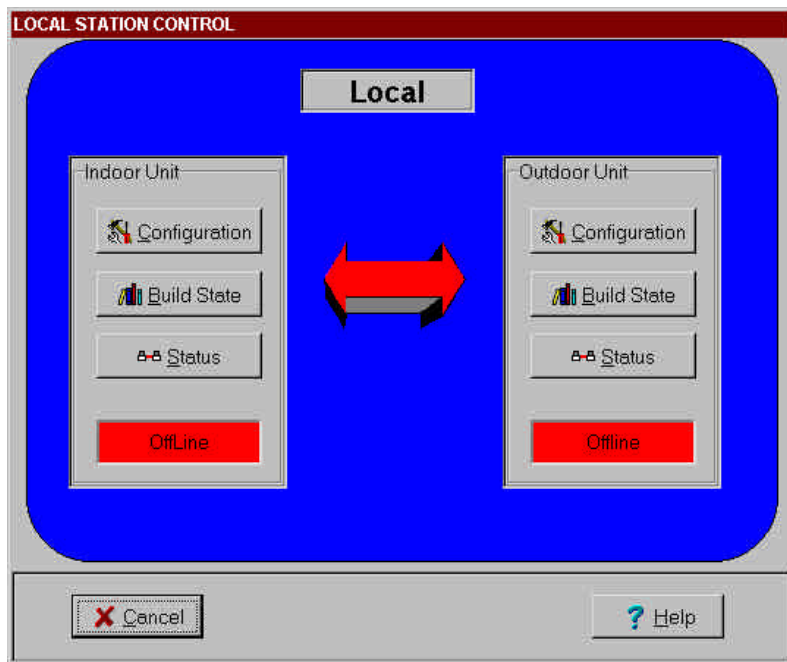

Figure 13. Typical Station Control Screen.

**Station Control  
Screen**

See Figure 13. This screen allows you access to the following parameters:

- a. Indoor Unit
  - Configuration
  - Build State
  - Status
- b. Outdoor Unit
  - Configuration
  - Build State
  - Status

Also provided on the screen are status indicators for both the IU and OU. These blocks are bi-coloured and indicate whether the unit is Online (Green) or Offline (Red).

---

**Indoor Unit:  
Configuration**

This screen allows you configure the following items (see Figure 14):

- Wayside Port
- Payload Data Interface Port
- Bit Error Rate Thresholds

To configure the ports, click on the required parameter(s).

Configure the BER thresholds as required. Payload is from the user equipment to the IU Payload Data connector and RF Link is from Antenna to Antenna. Note that the thresholds must be entered in scientific notation, eg. 1.0E-6. If the Minor or Major thresholds are exceeded, it will trigger a Service Alarm fault. If the Critical threshold is exceeded, it will trigger a Fail alarm.

When finished, click on the <Apply> button. This transmits the parameters to the selected IU.

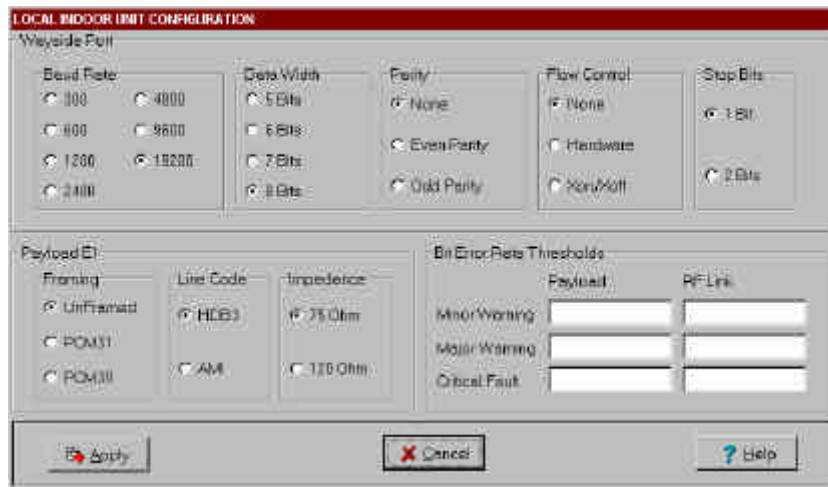

Figure 14. Indoor Unit: Typical Configuration Screen.



**Indoor Unit: Build State**

This screen (see Figure 15) allows you to view the build state details of the primary hardware and software components of the IU. This information is read from the IU microprocessor.

The screenshot displays a window titled "LOCAL INDOOR UNIT BUILD STATE". The window is divided into two main sections: "Production Main Board" and "Transceiver Board".

**Production Main Board:**

- Serial Number:
- Software Version:

**Transceiver Board:**

- Serial Number:
- Board Type:

At the bottom of the window, there are two buttons: "Cancel" (with a red 'X' icon) and "Help" (with a blue question mark icon).

Figure 15. Indoor Unit: Typical Build State Screen.

**Indoor Unit: Status** This screen (see Figure 16) allows you to monitor the network’s performance. It provides the following data:

- Status of the Near and Far site **Fail, Site** and **Service** alarms.
- Status of the **Rx Sync, Tx Sync, LOS** and **AIS** alarm LEDs.
- Transceiver Error Counts for **Code Violation, CRC4** and **FAS**.
- Bit Error Rate and Total Blocks of payload data transmitted.

If you want to clear the LEDs, simply click on the <Clear LEDs> button.

If you want to clear the Error Counts, simply click on the <Clear Counts> button.

You can see more details of the **Fail, Site** and **Service** alarms by clicking on the respective highlight button.

This initiates the selected site IU Detailed alarm screens (see Figure 17, Figure 18 or Figure 19 respectively).

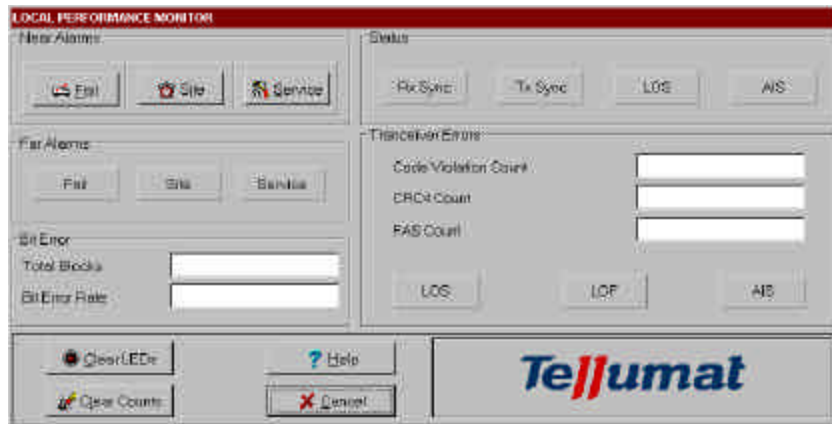

Figure 16. Indoor Unit: Typical Status Screen.

**Indoor Unit:  
Failure Alarm  
Details**

This screen (see Figure 17) provides more detailed information of the Near and Far site **Fail** alarms.

The specific cause of the error is shown by a tick in the adjacent check box of the suspected error.

Refer to Chapter 5 of this manual to fault-find the failure alarm.

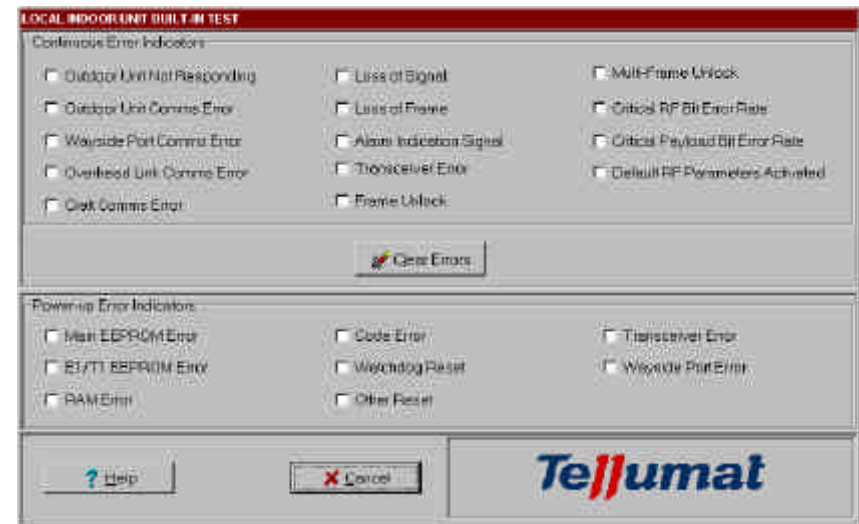

Figure 17. Indoor Unit: Typical Failure Alarm Details Screen.

**Indoor Unit: Site Alarms and Control**

This screen (see Figure 18) provides more detailed information of the selected sites **Site** alarms. It also allows you to test alarm relays.

The specific cause(s) of the site alarm is shown by a tick in the adjacent check box of the alarm.

To trigger (test) a relay, click in the relevant Control checkbox and the click on the <Apply> button. The selected relay will be triggered.

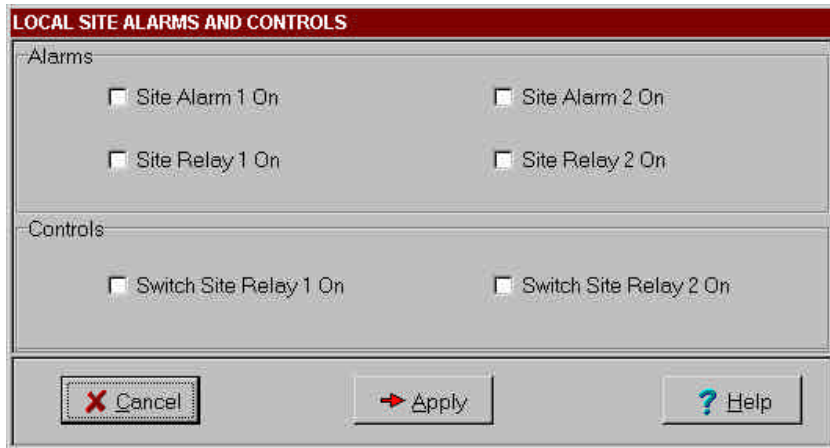

Figure 18. Indoor Unit: Typical Site Alarms and Control Screen.

**Indoor Unit:**  
**Service Alarms**

This screen (see Figure 19) provides more detailed information of the selected site's **Service** alarms.

The specific cause(s) of the alarm is shown by a tick in the adjacent check box of the listed BER warnings.

Refer to Chapter 5 of this manual to fault-find the Service alarm.

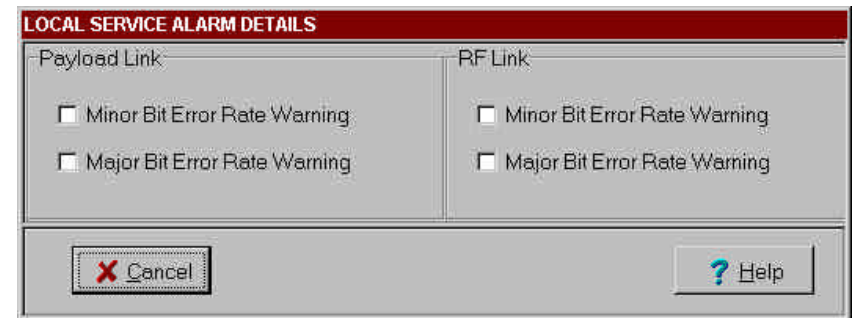

**Figure 19. Indoor Unit: Typical Service Alarm Details Screen.**

**Outdoor Unit:  
Configuration**

This screen allows you configure the following  
**Default** and **Current** OU parameters (see Figure 20):

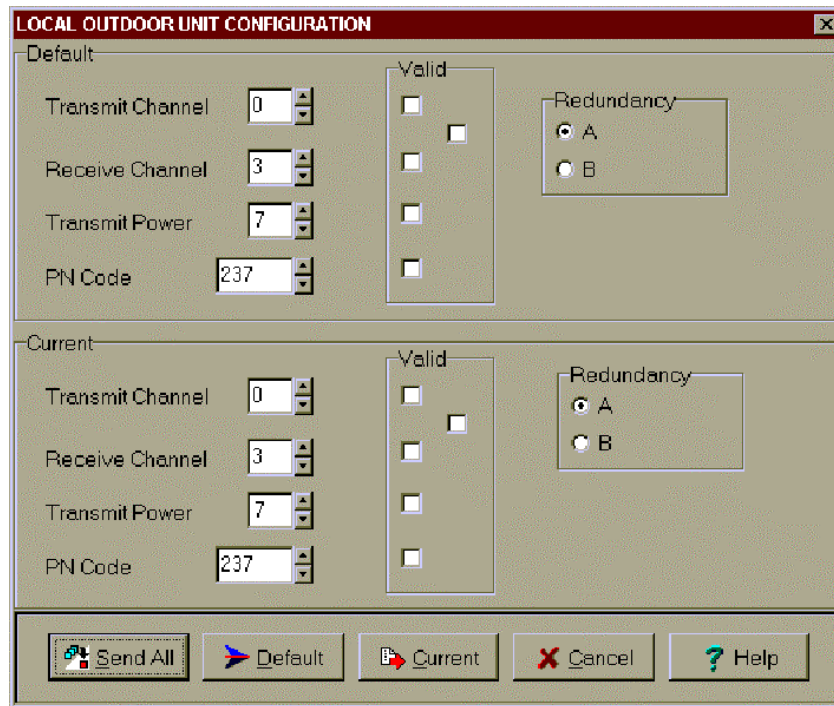

Figure 20. Outdoor Unit: Typical Configuration Screen.

**Default and  
Current  
Parameters**

---

The following parameters can be configured for **Default** and **Current** settings:

- **Transmit Channel.** Channel 0 to 11 (see *Frequency Band Plan* on page 19 of this manual).
- **Receive Channel.** Channel 0 to 11 (see *Frequency Band Plan* on page 19 of this manual). We recommend that transmit and receive channels be set at least three channels apart.
- **Transmit Power.** 1 to 7. 1 being the minimum power level (20 dBm) and 7 being the maximum power level (26 dBm).
- **PN Code.** A number between 0 and 999. For optimal performance this should be “237” (Barker code for an 11 bit PN sequence).
- **Redundancy (A or B).** If the hardware configuration allows (ie. equal gain antennas and standard power system), the transmit and receive paths can be swapped. This changes the effective polarisation's of the Tx and Rx signals and can be used to counteract multipath effects. Dual redundancy can also be used in the event of a RF transceiver failure.

To configure and program the default parameters, set the required parameters and then click on the <Default> button.

To configure and program the current parameters, set the required parameters and then click on the <Current> button.

To configure and program the default and current parameters, set the required parameters and then click on the <Send All> button.

If the parameters sent to the OU are valid, the relevant **Valid** check boxes will be ticked.

---

**Outdoor Unit:  
Build State**

This screen allows you to view the following build state details of the primary hardware and software components of the OU (see Figure 21). This information is read from the OU microprocessor.

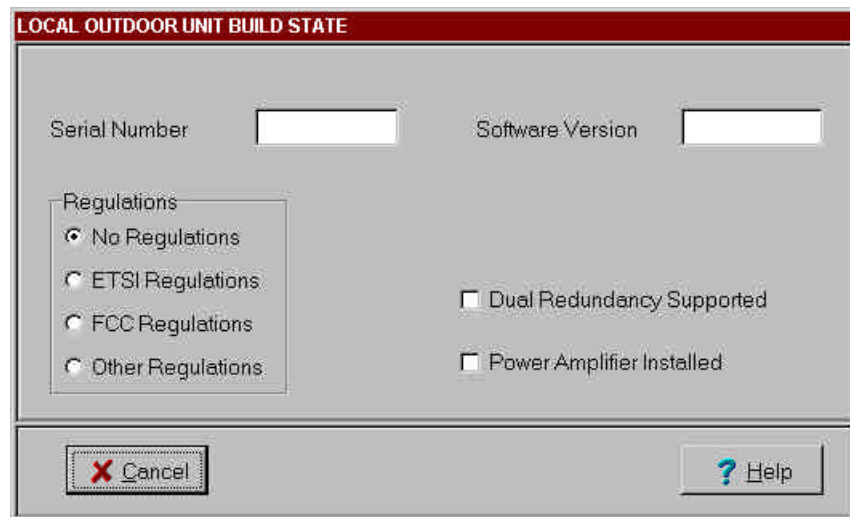

**Figure 21. Outdoor Unit: Typical Build State Screen.**



**Outdoor Unit:  
Status**

This screen allows you to view the following OU status information (see Figure 22):

- Last Restart
- Carrier Detect Present (Y/N)
- Received Signal Strength Indication (RSSI) in dBm.
- RSSI bar graph

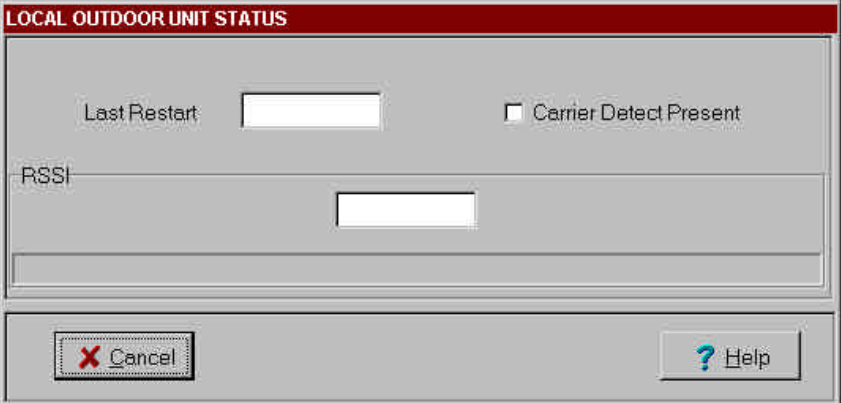

LOCAL OUTDOOR UNIT STATUS

Last Restart:   Carrier Detect Present

RSSI:

Figure 22. Outdoor Unit: Typical Status Screen.

**This page intentionally blank**

## Chapter 5: Maintenance Information

---

### Introduction to Chapter 5

Chapter 5 provides the technical personnel with the information necessary to diagnose and repair (by replacement) a fault on the μLink System.

Recommissioning information for the μLink is also provided to ensure that the system is functioning correctly after repair or replacement of the LRU/SRU.

---

### Fault Diagnosis

To ensure the minimum down-time of the μLink System, fault diagnosis is divided into two distinct categories:

- Diagnosing the most likely faulty site (Near or Far).
- Diagnosing the faulty LRU at the site, ie. Indoor Unit, Outdoor Unit, Antenna or Interconnection Cable.

**Information to follow**

---

**This page intentionally left blank**

## Chapter 6: Functional Description

---

### Introduction to Chapter 6

Chapter 6 provides a detailed description of the μLink System as well as a brief description of the Line Replaceable Units (LRUs) comprising the system. This chapter is aimed at providing the service technician with an understanding of the function and operation of the μLink System.

---

### μLink System Description

The μLink System is a Direct Sequence Spread Spectrum Digital Radio operating in the 2.4 GHz ISM frequency band. Various payload data interfaces can be installed, ie. T1 and E1. The μLink system can be extended to include other frequency bands merely by using a different microwave transceiver in the Outdoor Unit (OU). The Indoor Unit (IU) is not dependent on the frequency band used.

A μLink Radio Relay Station comprises a single IU, an OU (with integral antenna), interconnected by a custom cable. On-site management and maintenance is achieved by using a Craft Terminal that interfaces to the IU.

A radio relay link consists of a complementary pair of μLink stations. It is possible to extend range by linking further station pairs in a multiple hop configuration.

The following options may be added to a μLink Digital Radio System:

- Local area network for networking of multiple radio relay stations.
  - IP routers, bridges, and gateways for networking to the Telecommunications Network Management (TNM) system.
-

---

***Indoor Unit***

---

**Information to Follow**

## Chapter 7: Parts List

---

### Introduction to Chapter 7

Chapter 7 identifies, lists and describes all system level user replaceable parts and components comprising the μLink System. Part numbers for re-ordering purposes are also provided.

---

### Parts Lists

The columns in the parts lists provide the following information:

- **Item:** Indicates the annotation number referenced in the associated parts list illustration in Figure 23.
- **Part No.:** Gives the Tellumat part number for the specific item.
- **Description:** Provides a brief description of the item.
- **Qty.** States the quantity of the item used per Indoor Unit.
- **Remarks:** Provides any useful supplementary information.

Figure 23 shows the user replaceable parts and components at the system level. Table 9 shows the actual parts list.

---

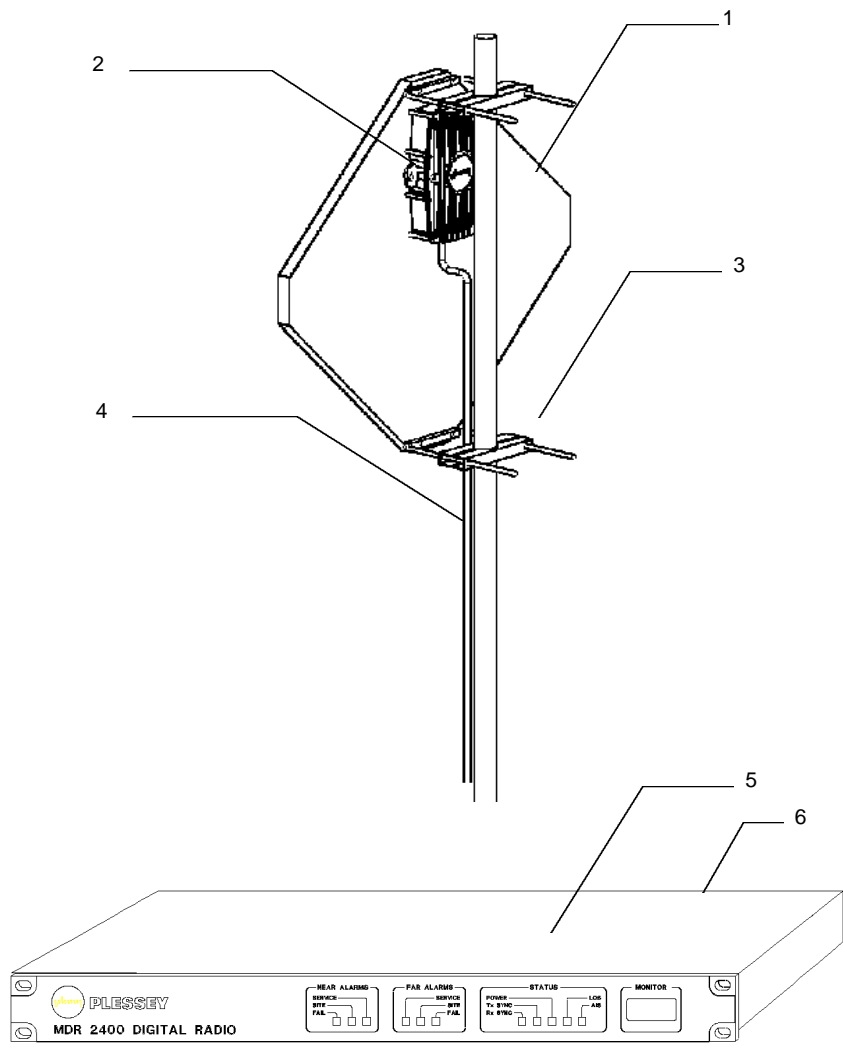

Figure 23. μLink System.



<b>Item</b>	<b>Part Number</b>	<b>Description</b>	<b>Qty.</b>	<b>Remarks</b>
1	651-03531	Antenna (18dBi Tx/18dBi Rx gain)	1	
2	651-03586	Outdoor Unit (E1 HB)	1	See Note 1
2	651-03587	Outdoor Unit (E1 LB)	1	See Note 1
2	651-03592	Outdoor Unit (T1 HB)	1	See Note 1
2	651-03593	Outdoor Unit (T1 LB)	1	See Note 1
2	651-03584	Outdoor Unit (E1 Diplexer HB)	1	See Note 1
2	651-03585	Outdoor Unit (E1 Diplexer LB)	1	See Note 1
2	651-03590	Outdoor Unit (T1 Diplexer HB)	1	See Note 1
2	651-03591	Outdoor Unit (T1 Diplexer LB)	1	See Note 1
3	651-03594	Antenna Mounting Bracket Set	1	
4	660-03152	IU/OU Interconnection Cable (10m)	1	
4	660-03531	IU/OU Interconnection Cable (20m)	1	
4	660-03150	IU/OU Interconnection Cable (50m)	1	
4	660-03149	IU/OU Interconnection Cable (75m)	1	
5	651-03533	Indoor Unit		
6	651-03526	E1 Interface Card		See Note 2
6	651-03527	T1 Interface Card		See Note 2

**Note 1: Check that Outdoor Units are ordered as a matched pair and ensure that they are of a complimentary type, ie. low band (LB) or high band (HB) types at opposite ends of the link.**

**Note 2: Only one interface card (E1 OR T1) is installed in the Indoor Unit.**

**This page intentionally left blank**