

MDR2400 and MDR5800

Digital Radio

User Manual

Document Number: 862-01881

Issue Status

Issue	Revised Pages/Amendments
1	1
2	31
3	2
4	General – terminology definition PER used instead of BER to remove interpretation ambiguity between Block Error Rate and Bit Error Rate. Note Block (equivalent to packet) concept is still maintained within sections describing G.826 parameters to maintain consistency with G.826 terminology.
5	MIB Description chapter added, RESET Button Additions, chapter on setup of a serial connection between a PC/Laptop and the Element Management Port, IP network address description diagrams.
6	Amendments related to customer furnished equipment, Outdoor Unit temperature range update, Maintenance and Ordering section updates, Appendix added regarding Antennas.
7	Update on RESET Button functionality description, MIB definition additions, product receive sensitivity level adjustment, FCC notice updates (Warning – this page, Antenna Information – Appendix E), NMS picture update. Appendix D Indoor Unit firmware Upgrade Notice added. Appendix B MIB Elements ResetAllRFPPerformanceData and ResetAllG826 deprecated.
8	Added detail for new MDR2400 Outdoor Unit Added detail for new Indoor Unit – balanced and unbalanced connectors

FEDERAL COMMUNICATIONS COMMISSION NOTICE

The equipment has been tested and found to comply with the limits for a Class A digital devices, pursuant to Part 15 of the FCC Rules.

These limits are designed to provide reasonable protection against harmful interference when the equipment is operated in a commercial environment. This equipment generates, uses, and can radiate radio frequency energy and, if not installed and used in accordance with the instruction manual, may cause harmful interference to radio communications.

Operation of this equipment in a residential area is likely to cause harmful interference in which case the user will be required to correct the interference at his own expense.

The manufacturer is not responsible for any radio or TV interference caused by unauthorized modifications to this equipment. Such modifications could void the user's authority to operate the equipment.

This device complies with Part 15 of the FCC Rules. Operation is subject to the following two conditions: (1) this device may not cause interference, and (2) this device must accept any interference, including interference that may cause undesired operation of the device.

	<p>WARNING- To comply with FCC RF exposure limits, the antennas for this transmitter must be fix-mounted to provide a separation distance of 2 meters (6.6 ft) or more from all persons to satisfy RF exposure requirements.</p>
---	---

This equipment must be professionally installed.

Note The MDR2400 frequency output must be limited to between 2412MHz and 2458MHz and the power to a maximum of +18dBm for the recommended antennas for compliance to FCC standards, U.S. only.

INDUSTRY CANADA NOTICE

This device has been designed to operate with an antenna having a maximum gain of 42 dB. Antenna having a higher gain is strictly prohibited per regulations of Industry Canada. The required antenna impedance is 50 ohms.

Operation is subject to the following two conditions: (1) this device may not cause interference, and (2) this device must accept any interference, including interference that may cause undesired operation of the device.

Exposure of Humans to RF Fields

The installer of this radio equipment must ensure that the antenna is located or pointed such that it does not emit RF field in excess of Health Canada limits for the general population; consult Safety Code 6, obtainable from Health Canada's website: www.hc-sc.gc.ca/rpb

Publication Number: 862-01881

Issue 8

June 2002

© 1999 Tellumat (Pty) Limited

The information contained herein is the property of Tellumat (Pty) Limited and is supplied without liability for errors or omissions. No part may be reproduced, used or disclosed except as authorised by contract or other written permission. The copyright and the foregoing restriction on reproduction, use and disclosure extend to all media in which this information may be embodied, including magnetic or electronic storage etc.

Table of Contents

	Page
1 INTRODUCTION	9
1.1 MDR2400 and MDR5800 Description	9
2 TECHNICAL DESCRIPTION	11
2.1 System Overview	11
2.2 Outdoor Unit	11
2.2.1 Frequency plans	11
2.2.2 RF Power Output Options	14
2.2.3 MDR2400 and MDR5800 Outdoor Units	14
2.3 Indoor Unit	15
2.3.1 Payload Interface Options	15
2.3.2 Reset/Configuration Button	16
2.3.3 Service (Wayside) Serial Data Channel	17
2.3.4 Element Manager Port	18
2.3.5 10BaseT Ethernet RJ45 Port	18
2.3.6 IU/OU Link LED	18
2.3.7 IU/OU Data Interconnect RJ45	18
2.3.8 IU/OU Power Interconnect	19
2.3.9 Auxiliary In/Out Port	19
2.3.10 DC Power Input	19
2.3.11 Fuse Holder	19
2.3.12 ON/OFF Switch	19
2.3.13 Ground Terminal	19
3 PLANNING	21
3.1 System Type Selection	21
3.1.1 Antenna selection (MDR5800)	21
3.1.2 Antenna selection (MDR2400)	21
3.2 Site Evaluation	22
3.3 Multipath Effects	22
3.4 Interference Considerations	23
3.5 Microcell Backhaul Applications of MDR Digital Radios	24

3.5.1	Setting the Transmitted Power Levels	24
3.5.2	Frequency Multiplexing	24
3.5.3	Antenna Isolation	24
4	INSTALLATION	26
4.1	Customer Furnished Tools and Equipment	27
4.2	Indoor Unit	28
4.2.1	Introduction	28
4.2.2	Installing the Indoor Unit in a Rack	28
4.2.3	Connecting a DC Power Supply	29
4.2.4	Balanced Payload Data	30
4.2.5	Unbalanced Payload Data	31
4.2.6	Connecting Auxiliary In/Out (Optional)	31
4.2.7	Connecting the Service (Wayside) Serial Channel (Optional)	32
4.2.8	Connecting the Element Manager Port	32
4.3	Outdoor Unit	33
4.3.1	MDR Outdoor Unit	33
4.4	Interconnection Cable Installation	34
4.4.1	INTERCONNECTION CABLE WIRING DESCRIPTION	35
5	ANTENNA ALIGNMENT AND SOFTWARE SETUP	37
5.1	Installation Equipment Required	37
5.2	Information Required	37
5.3	Antenna Alignment	37
5.3.1	Introduction	37
5.3.2	Alignment Procedure	38
5.3.3	Set Transmitted Power Level	39
5.4	Software Setup	40
5.5	Functional Test	40
5.5.1	Link Bit Error Rate Performance Test	40
5.6	MDR Installation Record	41
5.7	MDR Test Record	42
6	NMS SOFTWARE	44
6.1	Introduction to the Network Management System	44
6.2	General Information	44

6.2.1	Microwave Digital Radio	45
6.3	Main Screen	46
6.3.1	Link Elements Areas	47
6.4	NMS Menus	48
6.4.1	Main Screen Menus	48
6.4.2	Main Screen Short-cut Buttons	50
6.5	Indoor Unit Configuration	50
6.5.1	Controls	50
6.5.2	Menu Items	52
6.6	Outdoor Unit Configuration	56
6.6.1	Controls	56
6.6.2	Menu Items	57
6.6.3	OU Station Info	57
6.6.4	Outdoor Unit Status	58
6.7	RF Link Error Status Monitoring	58
6.7.1	RF Link Status	58
6.7.2	Packet Error Rate Thresholds	59
6.7.3	RF Link Error Monitor	60
7	MAINTENANCE INFORMATION	63
8	TECHNICAL DATA	65
8.1	Environmental Requirements	65
8.1.1	Outdoor Equipment	65
8.1.2	Indoor Equipment	65
8.2	Mechanical Information for Outdoor Equipment	65
8.2.1	MDR2400 and MDR5800 Outdoor Unit	65
8.3	Mechanical Information for Indoor Equipment	65
8.4	Power Supply Requirements	65
8.5	Electrical Performance	66
8.5.1	General Characteristics	66
8.5.2	Transceiver Characteristics	67
8.5.3	RF Interface	68
8.5.4	Payload Data Interfaces	68
8.5.5	Auxiliary Input Interface (CONTACT CLOSURE)	69

8.5.6	Auxiliary Output Interface	69
8.5.7	Wayside channel interface	69
8.5.8	Element Manager Port Interface	69
8.5.9	Indoor/Outdoor Unit Interface	69
8.6	Ordering Information	71
9	APPENDIX A: ELEMENT MANAGER PORT POINT-TO-POINT SERIAL COMMUNICATIONS SETUP	
	76	
9.1	Adding a Modem : Windows NT	76
9.2	Adding Dial-up Networking : Windows NT	81
9.2.1	To add dial-up networking	81
9.3	Adding a Modem : Windows 95/98	86
9.4	Adding Dial-up Networking : Windows 95/98	89
10	APPENDIX B: MANAGEMENT OF THE MDR2400 AND MDR5800	91
10.1	SNMP and the MDR	91
10.2	The MIB Elements – OID (Object ID) DESCRIPTIONS	93
10.3	The MIB elements – TRAP DESCRIPTIONS	106
11	APPENDIX C: SETUP OF A PC (WIN 95, 98, NT) TO ALLOW PINGING OF A 'REMOTE'-CONFIGURED INDOOR UNIT	108
11.1	IP CONFIGURATION OF THE MDR – ROUTING CONFIGURATION	108
11.2	IP CONFIGURATION OF THE MDR – BRIDGING AND ROUTING CONFIGURATION	110
12	APPENDIX D: MDR5800 HARDWARE VERSION 1, 2.X DIFFERENCES, COMPATIBILITY SUMMARY	
	111	
13	APPENDIX E: MDR5800 FIXED ANTENNAS	113
14	APPENDIX F: USEFUL WEB LINKS	114
15	APPENDIX F: MDR5800 SCALABLE 1-TO-4 E1 / 10 BASE-T ETHERNET FUNCTIONALITY	115

List of Abbreviations

BIT	Built-in-Test
AIS	Alarm Indication Signal
PER	Packet (or Block) Error Rate
DC	Direct Current
DCE	Data Communications Equipment
DRL	Digital Radio Link
DRS	Digital Radio Station
DTE	Data Terminal Equipment
IU	Indoor Unit
ISM	Industrial, Scientific and Medical
LED	Light Emitting Diode
LOS	Loss of signal
Mbps	Megabits per second
N.C	Normally-closed
N.O	Normally-open
NMS	Network Management System
OU	Outdoor Unit
PC	Personal Computer
RF	Radio Frequency
RSSI	Received Signal Strength Indication
SNMP	Simple Network Management Protocol

1 INTRODUCTION

1.1 MDR2400 and MDR5800 Description

The MDR2400 and MDR5800 are ISM band digital radio systems that provide short to medium range, point-to-point digital communication with high data security at rates of E1, 2E1 or 4E1. Alternatively, the radio can be software configured to convey T1, 2T1 or 4T1. The radio can also be configured to bridge or route IP via a 10BaseT port. The data rates scale depending on the number of enabled E1/T1 tributaries and whether the data is being bridged or routed. The products make use of spread spectrum technology and may be operated license-free in the 2.4GHz and 5.8GHz ISM bands. They are ideal for applications such as:

- Telecommunications companies, cellular operators and private carriers.
- Cellular/PCS base station interconnects.
- Internet distribution.
- Video surveillance data distribution.
- Rural communications.

The MDR2400 and MDR5800 consists of two main parts:

- An Outdoor Unit operating in the 2.4 GHz or 5.8 GHz ISM frequency bands.
- An Indoor Unit, available with a Telecommunications (1, 2 or 4E1 or 1, 2 or 4T1) interface and a Data interface (10BaseT Ethernet).

Interconnection between the Outdoor Unit and Indoor Unit is achieved using a low-cost UV-protected STP (Screened Twisted Pair: 4 pairs) data cable and a UV-protected 2-core power cable. The MDR2400 and MDR5800 series products use a split Indoor Unit and Outdoor Unit configuration for lowest loss between the antenna and the transceiver, thereby ensuring optimal long-range performance.

MDR2400 and MDR5800 Outdoor Units uses a Type-N RF (female) output connector for connection to any 2.4GHz or 5.8 GHz antenna for applications where long range is required.

The system is available for use in FCC regulated countries.

Table 1 lists the MDR5800 model variants.

Table 1. MDR5800 model variants			
Model Number	Interfaces	Antenna Coupling	Antenna Type
MDR5800-ET1	E1/T1 10BaseT Ethernet	N-type Female	Customer supplied
MDR5800-ET2	2 x E1 / 2 x T1 10BaseT Ethernet	N-type Female	Customer supplied
MDR5800-ET4	4 x E1 / 4 x T1 10BaseT Ethernet	N-type Female	Customer supplied

This table lists the MDR2400 model variants.

Table 2. MDR2400 model variants			
Model Number	Interfaces	Antenna Coupling	Antenna Type
MDR2400-ET1	E1/T1 10BaseT Ethernet	N-type Female	Customer supplied
MDR2400-ET2	2 x E1 / 2 x T1 10BaseT Ethernet	N-type Female	Customer supplied
MDR2400-ET4	4 x E1 / 4 x T1 10BaseT Ethernet	N-type Female	Customer supplied

Refer to section 8 for Ordering details.

The Network Management System provides control and management of the product. SNMP support via an SNMP agent in the Indoor Unit ensures open network management compatibility.

Comprehensive data and RF loop-back functions ensure that the system is easy to install and maintain.

2 TECHNICAL DESCRIPTION

2.1 System Overview

An MDR digital radio link (DRL) consists of a pair of MDR radio stations.

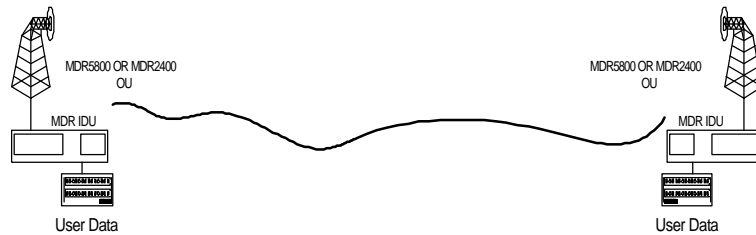

The MDR radio stations consists of two main parts:

- An Outdoor Unit operating in the 2.4GHz or 5.8 GHz ISM frequency bands. The Outdoor Unit provides the radio transceiver functionality by accepting radio link data from the Indoor Unit and converting it to the 2.4GHz or 5.8 GHz ISM frequency band using spread spectrum modulation. The received signal is de-spread and transmitted to the Indoor Unit in a digital format.
- An Indoor unit, available with 1, 2 or 4 E1 and 1, 2 or 4 T1 data interfaces (choice of E1 or T1 is software selectable). The Indoor Unit combines nE1 or nT1 data with Wayside Service Channel serial data and link IP data to be transmitted across the radio link. The Indoor Unit also provides power to the Outdoor Unit.

Interconnection between Outdoor Unit and Indoor Unit is achieved using low cost data and power cables.

2.2 Outdoor Unit

The MDR2400 and MDR5800 Outdoor Units make use of Spread Spectrum modulation technology for license-free operation in the 2.4GHz and 5.8 GHz ISM bands.

For MDR operation, the ISM bands are divided into upper and lower frequency sub-bands. An MDR 'High Band' Outdoor Unit transmits in the higher frequency sub-band and receives in the lower frequency sub-band, while a 'Low Band' Outdoor Unit transmits in the lower sub-band and receives in the higher sub-band. An MDR radio link will use a 'Low Band' Outdoor Unit on one end of the link to communicate with a 'High Band' Outdoor Unit on the other end.

The MDR Outdoor Units use a Type-N RF output connector for connection to suitable 2.4GHz and 5.8GHz antennas for applications where long range is required.

The system is available for use in FCC regulated countries.

2.2.1 Frequency plans

The MDR5800 Outdoor Units operate in the 5.725 GHz to 5.850 GHz ISM frequency band. The MDR5800 has predefined frequency channel plans (termed A, B, C and D).

The MDR2400 Outdoor Units operate in the 2.400 GHz to 2.4835 GHz ISM frequency band. The MDR2400 has predefined frequency channel plans (termed A, B and D).

2.2.1.1 MDR5800 Frequency Channel Plan A, B and C

The channel spacing is based on the bandwidth occupied by the spread spectrum signal (approximately 17 MHz) and is used to optimise link performance. In the case of plan A, plan B and C, note that both Outdoor Units of a link must be set up to the same frequency channel plan (i.e. A, B or C).

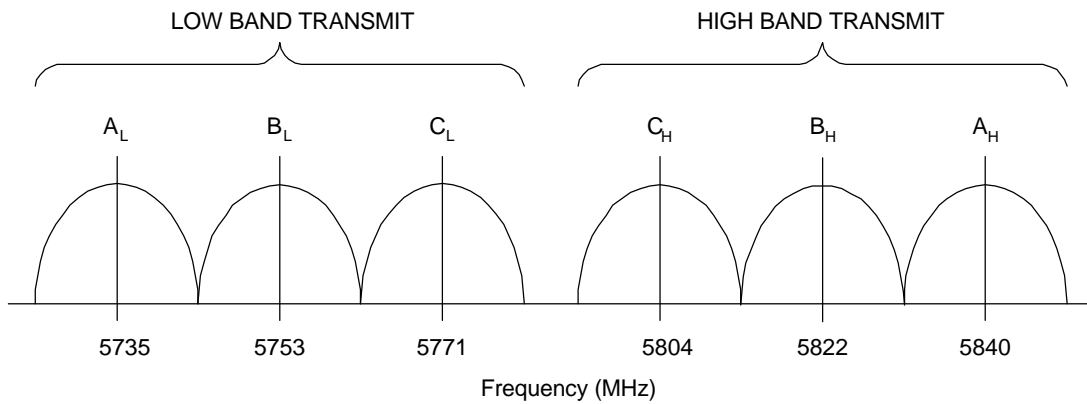

Figure 1. MDR5800 Frequency channel plans A, B and C

2.2.1.2 MDR2400 Frequency Channel Plan A, B (non-FCC)

The channel spacing is based on the bandwidth occupied by the spread spectrum signal (approximately 17 MHz) and is used to optimise link performance. In the case of plan A and B, note that both Outdoor Units of a link must be set up to the same frequency channel plan (i.e. A or B).

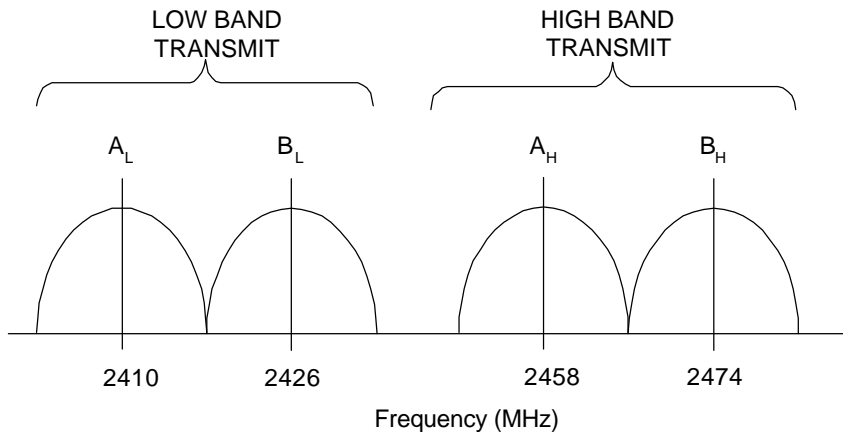

Figure 2. MDR2400 Frequency channel plans A and B

2.2.1.3 MDR2400 FCC Compliant Frequency Channels for the U.S. only

In countries where FCC compliance is required, only the following frequencies may be used:

Low band outdoor unit – 2412MHz to 2426MHz,

High band outdoor unit – 2458MHz.

Use frequency plan D (variable frequency) to set the outdoor unit.

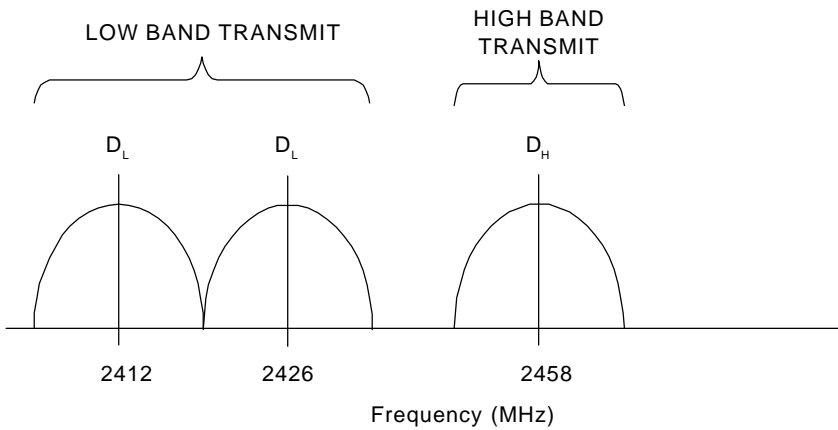

Figure 3. MDR2400 FCC Compliant Frequency Channels for the U.S. only

Frequency Channel Plan D

Frequency plan D allows independent control of transmit and receive frequencies. This enables a very flexible frequency plan and can be used to overcome interference in the 2.4GHz and 5.8 GHz ISM bands.

The frequencies that can be used in the lower or upper sub-bands can be selected in 1 MHz increments. Performance degradation can be expected when operating using channel plan D mode and the chosen frequencies are close to the sub-band edges i.e. a choice of one of the high frequencies in the lower sub-band and one of the lower frequencies in the upper sub-band.

The allocation of Channel plan D frequencies is shown in Table 3 and Table 4.

Note the allowable operation range in FCC countries, page 13.

Table 3. MDR2400 Channel plan D channel frequencies	
Sub-band	Center Frequency (MHz)
L	2410-2426
H	2458-2474

Table 4. MDR5800 Channel plan D channel frequencies	
Sub-band	Center Frequency (MHz)
L	5735-5771
H	5804-5840

2.2.2 RF Power Output Options

The Outdoor Unit is designed for use in countries that have adopted FCC standards. It is possible to adjust the output power on the OU using the supplied NMS software or a SNMP Management application. The FCC standards for the MDR2400 unit require a limited output power as stated on page 2, U.S. only.

2.2.3 MDR2400 and MDR5800 Outdoor Units

The MDR2400 and MDR5800 Outdoor Units transmit and receive RF through a diplexer interfaced via an RF cable to an external antenna. The unit has a type-N connector for connection to the RF cable used between the OU and the antenna.

The MDR Outdoor Units house the following main parts:

- Transmit/Receive Modules
- Baseband Modulator/Demodulator Circuitry
- Microcontroller/Framing & Buffering Circuitry
- Power Amplifier
- Diplexer

2.3 Indoor Unit

The Indoor Unit is designed for mounting in a 19" rack, occupying a 1U slot, or can be table-top standing.

The Indoor Unit accepts user nE1/nT1 and combines it with Wayside Service Serial Data and IP data to be transmitted across the radio link.

The Indoor Unit is fitted with a DC power supply.

A firmware variant exists that determines whether the Outdoor Unit is an MDR2400 or MDR5800. The Indoor Unit hardware is independent of the type of Outdoor Unit i.e. whether it is an MDR2400 or MDR5800.

2.3.1 Payload Interface Options

The Indoor Unit can be configured for nE1 or nT1 operation.

- 1, 2 or 4 x E1 (2.048 Mbps)
- 1, 2 or 4 x E1 (1.544 Mbps)

For E1 connectivity, bipolar AMI or HDB3 line coding is software selectable.

For T1 connectivity, bipolar AMI or B8ZS line coding is software selectable.

MDR MTE 75/120 OHM INDOOR UNIT 651-04008-02

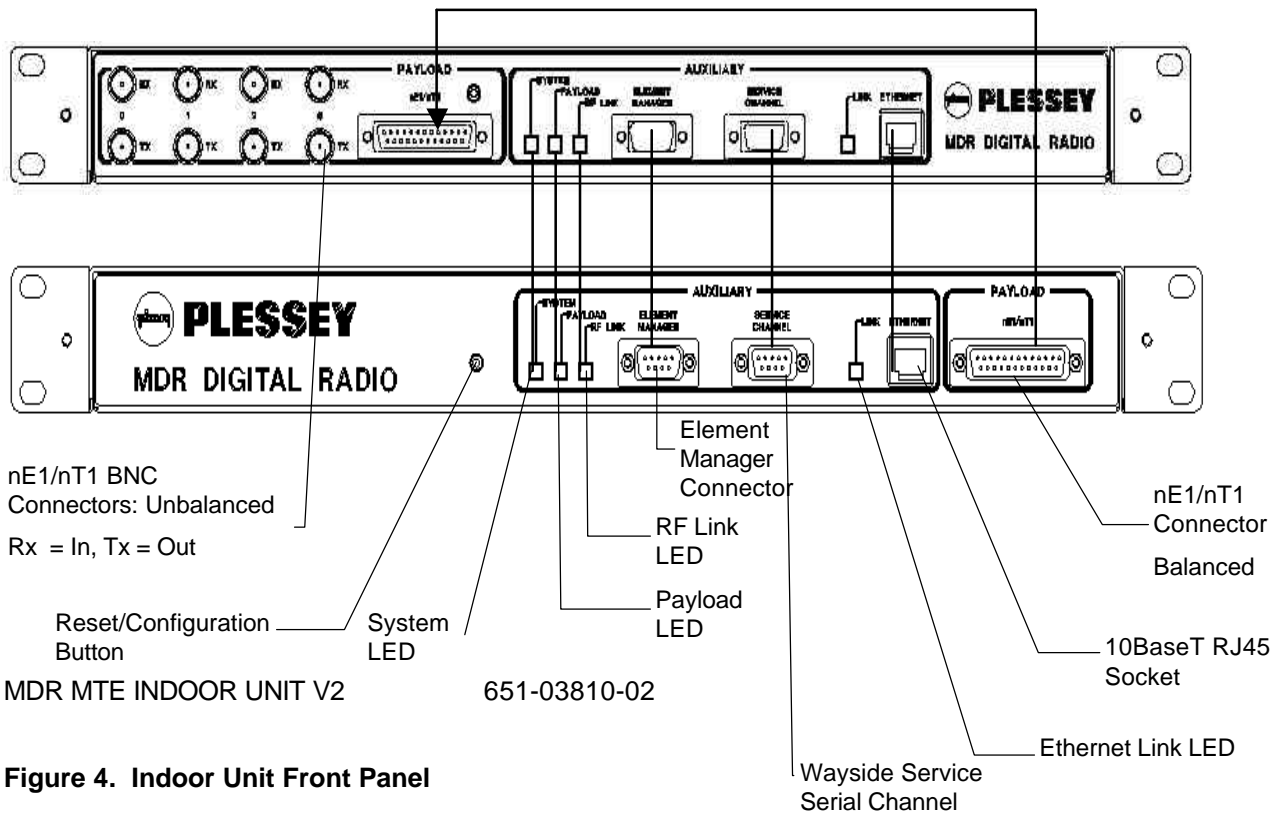

Figure 4. Indoor Unit Front Panel

The Indoor Unit LED functionality is described as follows:

SYSTEM

Green OK, Orange (OU/IU Comms Error), Red (OU/IU Comms Down)

PAYLOAD

Green OK, Orange (AIS Detected), Red (LOS Detected)

RF LINK

Green OK, Orange (FEC Correcting Errors), Red (FEC unable to correct errors)

In ALL cases flashing red and orange LEDs imply historic alarm conditions (The alarm can be cleared using the front panel button 'position 1' : see next section).

2.3.2 Reset/Configuration Button

The Front Panel Button has the following functionality used to setup a radio (as determined by different LEDs lighting up. 'Position 1' being RF Link LED (Green), 2 being Payload LED (Green), 3 being System LED (Green), 4 being RF Link LED (Orange), 5 being Payload LED (Orange) and 6 being System LED (Orange) etc.

1. Clear Front Panel LEDs (and associated alarms in IU)
2. Clear Event Log in the Indoor Unit
3. Reset the Indoor Unit (**don't** reset the non-volatile memory's store of the IU's configuration parameters)
4. Routed Configuration: Reset the IU configuration parameters that are stored in non-volatile memory (BATTERY-BACKED STATIC RAM) and configure as a 'Far Side IU' : i.e. for a ROUTED IP configuration, set the Ethernet IP address as 10.11.1.2, Element Manager IP address to 10.12.1.2
5. Routed Configuration: Reset the IU configuration parameters that are stored in non-volatile memory and configure as a 'Near Side IU' : i.e. for a ROUTED IP configuration set the Ethernet IP address as 10.2.1.2, Element Manager IP address to 10.13.1.2
6. Routed Configuration: If you are not sure how the IU is configured (NEAR or FAR side IU), reset it AS IS i.e. reset the 'Near Side IU' or 'Far Side IU' configuration parameters depending on how the IU is currently configured.
7. Bridged Configuration: Reset the IU configuration parameters that are stored in non-volatile memory (BATTERY-BACKED STATIC RAM) and configure as a 'Far Side IU' . For a BRIDGED IP configuration, see Appendix C of this document for a description of the default IP addresses.
8. Bridged Configuration: Reset the IU configuration parameters that are stored in non-volatile memory and configure as a 'Near Side IU'. For a BRIDGED IP configuration, see Appendix C of this document for a description of the default IP addresses.
- 9, 10, 11 RESERVED
12. Set up Indoor Unit with E1 tributaries.
13. Set up Indoor Unit with T1 tributaries.

14. Deactivate buttons 4 onwards.
15. Toggle SNMP and FTP Servers ON/OFF (V3.00+ firmware)
16. DHCP ON (V3.00+ firmware)
17. DHCP OFF (V3.00+ firmware)

NB : All buttons can be REACTIVATED (i.e. undoing a 14 'reset') by doing a power-on reset while holding the front-panel Reset Button in.

NOTE



POSITIONS 4, 5, 6, 7 and 8 RESET THE INDOOR UNIT TO FACTORY DEFAULTS – THESE RESETS ARE TYPICALLY ONLY USED ONCE (THESE CHOICES RESET CERTAIN ADJUSTABLE PARAMETERS IN NON-VOLATILE MEMORY IN THE INDOOR UNITS). IF CHANGES ARE MADE TO THE CONFIGURATION PARAMETERS AND THE USER DOES NOT WANT THESE TO CHANGE WHEN A UNIT IS RESET, THE INDOOR UNIT CAN BE POWER-CYCLED OR POSITION '3' MUST BE USED E.G. THIS TECHNIQUE IS USED IF THE IP ADDRESSES ASSOCIATED WITH THE NETWORK INTERFACES ARE ADJUSTED – THE PROCESSOR NEEDS TO BE RESET TO ALLOW THE CHANGE/S TO BE IMPLEMENTED.

IF YOU OVER-RUN THE SELECTION YOU REQUIRE, CONTINUE UNTIL THE LEDs GO BLANK – THEN, START AGAIN (OPTION AVAILABLE WITH RELEASE 2+ OF IU FIRMWARE).

2.3.3 Service (Wayside) Serial Data Channel

This port supports asynchronous full duplex, serial data transfer at a speed of 115200 bps.

The interface type is RS-232 configured as DCE (Data Communications Equipment).

Handshaking can be None, Hardware.

2.3.4 Element Manager Port

This port is used for communication with the NMS software or with an SNMP manager to control the MDR system. The port must be connected to a serial port (configured for a speed of 115200 bps) on a personal computer to use the NMS software.

The interface type is RS-232 configured as DTE (Data Terminal Equipment).

Hardware handshaking is used.

2.3.5 10BaseT Ethernet RJ45 Port

This port is used for communication with the NMS software or with an SNMP manager to control the MDR system.

The interface type is DTE (Data Terminal Equipment).

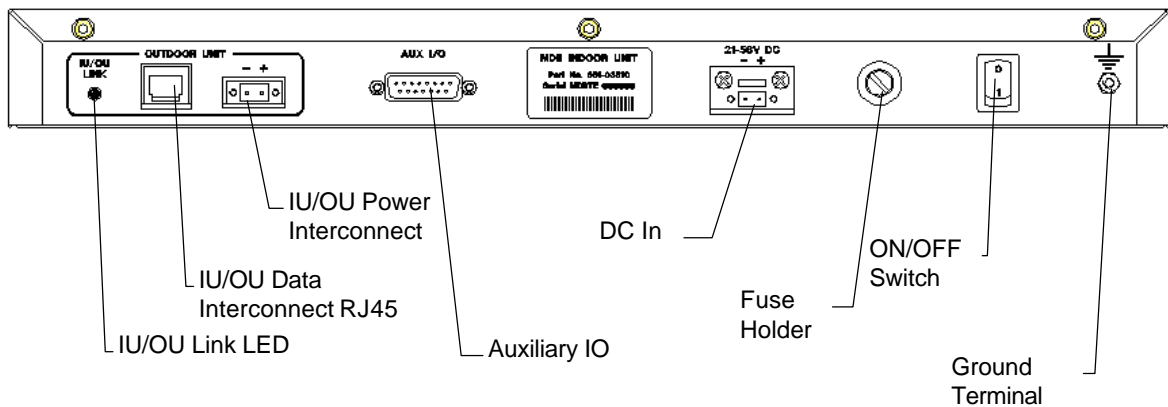

Figure 5. Indoor Unit Rear Panel : NOTE : SAME FOR BALANCED-ONLY (120 Ohm) AND 75/120 Ohm configurations.

2.3.6 IU/OU Link LED

This LED indicates if there is a suitable electrical connection between the Indoor and Outdoor Units¹.

2.3.7 IU/OU Data Interconnect RJ45

This receptacle accepts an RJ45 plug that connects to UV-protected STP (Screened twisted pair) cable used between the IU and the OU.

¹ Note that only the Ethernet Physical interface is checked on V1 hardware with this LED, not the RS232/485 interface. The integrity of the RS232/485 interface is checked using the front panel "System LED".

2.3.8 IU/OU Power Interconnect

This connector (socket) is used for power interconnection between the IU and the OU. The connection is made using UV-protected 2-core cable. The cable is connected to a GREEN connector, a plug. The polarity sense (labelled) must be maintained between the IU and the OU.

2.3.9 Auxiliary In/Out Port

The auxiliary in/out port is used for remote monitoring and control. The following are provided

- Two inputs (for sensing contact closure or opening) are provided to sense site alarm inputs. The states of these alarm inputs can be monitored with NMS, as well as from an SNMP Management Station.
- Two relay contact outputs, normally-open and normally-closed contacts, are provided as alarm / auxiliary outputs. Output states are software customised and controlled. The outputs are used to indicate alarm or other states selected by the operator via the NMS or a SNMP Management Station.

2.3.10 DC Power Input

This connector (socket) is used for power input to the IU. The connection is made using 2-core cable. The cable is connected to a GREY connector, a plug. The polarity-sense (labelled) must be observed and implemented.

2.3.11 Fuse Holder

This holder is used to hold a fuse (5A).

2.3.12 ON/OFF Switch

This switch is used to control power input to the Indoor Unit (and indirectly the Outdoor Unit).

2.3.13 Ground Terminal

This is used to accept connection to an earth strap, terminated with a crimped earth lug. Refer to the installation chapter for details on wire/earth lug requirements.

This page is left blank intentionally.

3 PLANNING

This chapter is aimed at management and planning staff to enable them to assess the requirements for installing an MDR digital radio link.

3.1 System Type Selection

The MDR system uses an Outdoor Unit with a type-N RF output for connection to a range of antennas.

The MDR is aimed at FCC regulated markets.

Antenna polarisation can be used to co-locate multiple MDR systems.

Antenna polarisation can be used to overcome interference.

3.1.1 Antenna selection (MDR5800)

The antenna type must be selected before the MDR5800 system is to be installed. The chosen antenna must enable the system to operate with sufficient link fade margin without excessive cost and allow the user's 'link availability requirements' to be met.

The main consideration when selecting an antenna is antenna gain measured in dBi. A path loss analysis is highly recommended to determine the antenna gain needed for adequate fade margin. The table below shows antenna selection guidelines for some configurations. The distances are calculated for a 20 dB link fade margin.

To reduce potential radio interference to other users, the antenna type and its gain should be so chosen that the equivalent isotropically radiated power (EIRP) is not more than that required for successful communication.

Table 5 MDR5800 Antenna Selection			
Antenna Type	Gain (dBi)	Distance (Km)	Power level (dBm)
0.15 m Flat panel	18	9	24
0.3 m Flat panel	24	30	24
0.6 m Flat panel	28	80	24

3.1.2 Antenna selection (MDR2400)

The antenna type must be selected before the MDR2400 system is to be installed. The chosen antenna must enable the system to operate with sufficient link fade margin without excessive cost and allow the user's 'link availability requirements' to be met.

The main consideration when selecting an antenna is antenna gain measured in dBi. A path loss analysis is highly recommended to determine the antenna gain needed for adequate fade margin. The table below shows an antenna selection guideline for a flat panel configuration. The distance is calculated for a 20 dB link fade margin.

To reduce potential radio interference to other users, the antenna type and its gain should be so chosen that the equivalent isotropically radiated power (EIRP) is not more than that required for successful communication.

Table 6 MDR2400 Antenna Selection			
Antenna Type	Gain (dBi)	Distance (Km)	Power level (dBm)
1.2 m Parabolic Antenna	27	80	18

3.2 Site Evaluation

When planning a site for a digital radio link, it is of the utmost importance that you take the operational environment of the proposed site into account.

The combined effect of atmospheric environmental factors such as rain and lightning, atmospheric attenuation, signal path obstruction, propagation fading, air temperature gradients, ice build-up, wind and solar radiation can contribute towards reducing the level of performance of the system. In the higher frequency bands, rainfall is the main attenuation mechanism that limits error performance. Ice and snow will have a similar effect. Severely cold and excessively warm climatic conditions outside the scope of the operating temperature range can affect the function of the system, especially the outdoor equipment (see *Environmental Characteristics* on page 65 of this manual).

Also, if masts are not sufficiently rigid, very strong winds can affect the antenna beam alignment and Outdoor equipment reliability due to wind force build-up and/or vibration of the mast-mounted equipment.

3.3 Multipath Effects

The MDR digital radio can be influenced by the effects of multipath propagation. Understanding these effects will help when installing an MDR digital radio link and maximise the reliability of the link.

Multipath fading occurs when the receiving antenna receives not only the direct signal from the transmitting antenna but also a signal from the transmitting antenna that has reflected off the ground or nearby obstacles. The reflected signal takes a longer path to reach the receiver and acts as interference since it is not in-phase with the direct path signal. The amplitude of the interference can be almost equal to that of the direct path signal, thus degrading the performance of the link.

Multipath propagation is dependent on transmit frequency and the specific geometry of the link such as antenna heights, distance between the antennas and the local terrain. To counteract multipath propagation, the installer can change the frequency at which the link operates or adjust the height of one or both of the antennas.

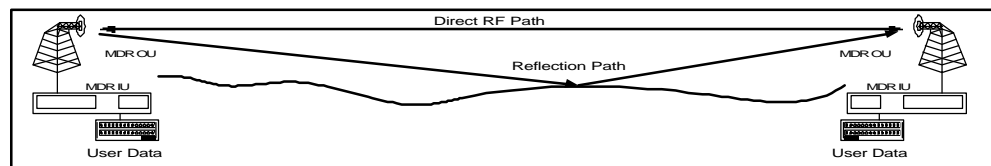

Figure 6. Multipath Effects.

3.4 Interference Considerations

The ISM frequency bands are used by devices that can cause interference to the MDR radio systems. Interference can be avoided by careful planning of the system installation. The available methods for providing isolation from interfering radiators are the following:

- Frequency diversity
- Antenna polarisation

It is recommended to scan the proposed installation areas (spectrum analyzer) to establish the presence of interference. The frequency spectrum should be scanned over a sufficient time period to ensure that periodic transmissions are recorded.

Interferers will cause problems if their amplitudes are not more than 20 dB below the intended receive power level. A link path loss calculation should be performed to determine the expected receive power level.

The procedure for selecting the optimum antenna polarisation and system frequency plan is the following:

- Perform a spectral analysis at each site in the link direction using a high gain antenna.
- Repeat the spectral analysis for vertical and horizontal polarisation.
- Select the polarisation with the lowest interfering levels as the system antenna polarisation.
- Consult the MDR frequency channel plans as shown in **section 2.2.1** and select the frequency plan that would operate in an interference-free band.
- Install the 'High Band' and 'Low Band' Outdoor Units at the sites where they would experience the lowest interference in their respective receive bands.

3.5 Microcell Backhaul Applications of MDR Digital Radios

In applications where more than one independent and separate links, need to radiate from a central site, a number of parameters can be taken advantage of, to provide isolation and minimise interference between these links:

- Frequency multiplexing
- Antenna polarisation
- Choice of High Antenna Gain

It is important to note that these methods only provide isolation between two radio Systems, and that power levels in the separate systems should be balanced to ensure correct operation.

3.5.1 Setting the Transmitted Power Levels

To minimise interference, received power levels should be balanced between separate radio links. This means that transmit power levels should be set to provide similar levels of received power, as indicated by the RSSI values of the adjacent receivers at the central site.

3.5.2 Frequency Multiplexing

The MDR2400 offers three frequency channel plans and the MDR5800 offers four frequency channel plans. A radio link requires two channels (one for transmit and one to receive) to provide full duplex operation. Each radio has a high and a low sub-band, one that it uses for transmission and another for reception. Terminology definition: the 'High-band Outdoor Unit' of a system transmits on the higher of the two sub-bands. The 'Low-band Outdoor Unit' of a system transmits on the lower of the two sub-bands. A system (link) always has one High Band and one Low Band Outdoor Unit. It is important to note that unwanted transmitted signals in adjacent frequency bands can affect other receivers operating in an adjacent band if insufficient antenna isolation is provided. A solution is to group high-band or low-band Outdoor Units at the central site, rather than group high and low-band Outdoor Units together.

3.5.3 Antenna Isolation

Separate links at a central site will have sufficient isolation when radio systems operate outside the radiation beamwidth or side lobes of the system antenna. The achievable isolation can be established by examining the measured radiation patterns of the system antennas. Directional isolation can be used if the antenna radiation is 15 dB or lower relative to the adjacent main beam. Antennas with high directionality will allow reduced angular separation of adjacent systems. Antenna cross-polarisation isolation can be used for adjacent radio links, radiating in the same direction. Typical isolation of 30 dB can be achieved using high quality antennas.

This page is left blank intentionally.

4 INSTALLATION

This chapter describes a recommended installation procedure for the MDR2400 and MDR5800.

Recommended installation procedure:

1. Install the Indoor Unit.
2. Prepare and connect the cables to the Indoor Unit.
3. Install the Outdoor Unit and antenna.
4. Install the Indoor-to-Outdoor Unit interconnection cables (the power and data cables).
5. Turn the Indoor Unit power on.
6. Perform the initial software setup using the supplied NMS application
7. Repeat item 1-5 for the remote site.
8. Align the antennas (use the RSSI voltage on the OU or the RSSI value from the MIB or the NMS Graphic User Interface to assist with the setup).
9. Perform a functional test and commission the link.
10. Connect to user data.
11. Start the system.

Installation of the MDR2400 or MDR5800 elements is described in the following sections:

- Installing the Indoor Unit.
- Installing the Outdoor Unit and Antenna.
- Installing the interconnection cables.

4.1 Customer Furnished Tools and Equipment

The following table lists tools and equipment required to install the MDR2400 or MDR5800 system.

General, IU-to-OU Interconnect

- Cable cutting and stripping tools.
- Earth lug crimp tools.
- 3 mm flat screwdriver - IU to OU power cable.
- RJ45 crimp tool - IU to OU data cable.
- Earth cable or strap rated at 45A with 5 mm earth lug for earthing the Indoor and Outdoor Units.
- Cable ties, used to secure the cables to the mast at regular intervals.

IU

- Pozi #2 screwdriver - IU mounting in a 19" rack and the earth lug.
- 2.5mm Allen key - To change the position of the IU mounting brackets.
- DC power supply cable: minimum 2.5 mm square conductor, rated for 10 A. For connection between the power supply and the Indoor Unit DC connector on the rear panel.
- IU earth lug: 10-4 (10 square mm for wire and hole big enough for M4 thread)

OU

- 13 mm wrench / spanner – used for attachment of OU to mounting bracket.
- 13 mm wrench / spanner – used for attachment of OU mounting bracket to pole.
- 2.5 mm Allen key - used to tighten OU connection box cover fasteners.
- OU earth lug: 10-8 (10 square mm for wire and hole big enough for M8 thread)

Please refer to Chapter 7 for details on the data and RF cables, which are also customer furnished equipment.

4.2 Indoor Unit

4.2.1 Introduction

This section describes the recommended installation procedure for the Indoor Unit. The Indoor Unit is designed for mounting in the DIN 41494 (19") racking standard and occupies a 1U high slot. Desktop mounting is also possible.

The Indoor Unit's payload (nE1, nT1 and 10BaseT Ethernet) and Service Channel ('Wayside serial') data interfaces and Element Management interface are located on the front panel. Input Power, Auxiliary alarm and 'IU/OU Interconnect' interfaces are located on the rear panel, suitable for rack installations.

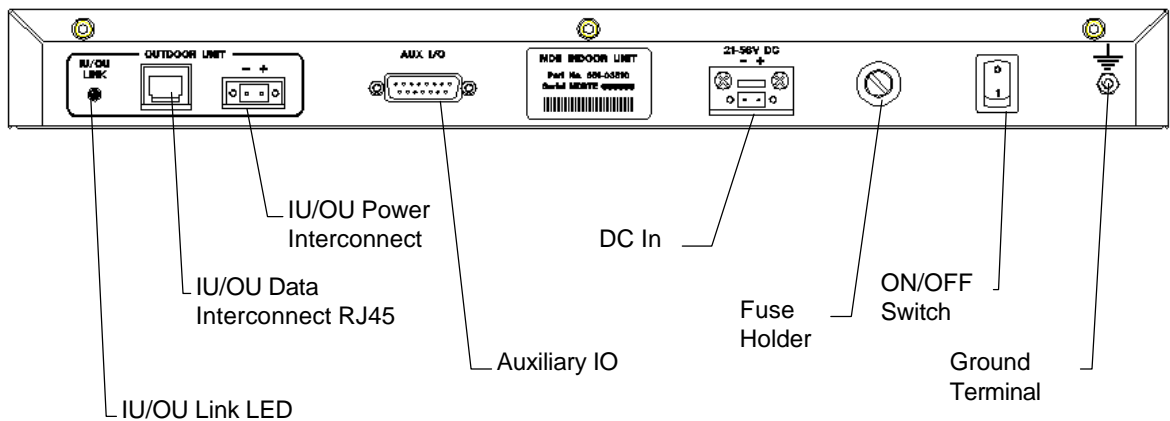

The recommended installation procedure for the Indoor Unit is the following:

- Install the Indoor Unit in the rack.
- Earth the Indoor Unit. This is required for safety and to minimise radiated emissions.
- Connect the DC power supply.
- Connect Payload data ports (front panel).
- Connect Auxiliary In/Out port (optional).
- Connect Service Channel (Wayside) serial port (optional).
- Connect the Element Manager port using the supplied cable (front panel).

4.2.2 Installing the Indoor Unit in a Rack

1. Slide the Indoor Unit into the 19" rack and secure to the rack using four M6 x 18 mm screws.
2. Earth the Indoor Unit by connecting the earth cable or strap between the station earth and the earth stud on the Indoor Unit rear panel.

4.2.3 Connecting a DC Power Supply



WARNING – See section 8.4 for specification of the power supply.

1. Observing the polarity of the supply, wire up the supplied power connector cable plug and connect it to the DC supply (21 to 56 V) through a minimum 5 A circuit breaker.
2. Check the supply voltage using a multimeter.
3. Secure the connector screws to the unit.

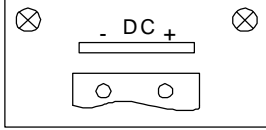
DC Power Connector Pinouts		
Indoor unit connector: GREY	Pin No	Signal
2-pin Wieland Type 8213 Socket 	+	DC POWER
	-	DC POWER RETURN

4.2.4 Balanced Payload Data

1. Assemble the (nE1) / (nT1) payload data input and output cable. See the table below for Indoor Unit connector pin assignments.
2. Connect the payload data cable to the DB25 connector on the front panel of the Indoor Unit.

Note: Rx implies IN (signal expected to go INTO the interface), Tx implies OUT (signal coming out of the interface)

D-Type Payload Data Connector Pin #	Pin Name	Tributary	Direction
1	GND Earth		N/A
2	RTIP1	1	RX +
3	RRING1	1	RX -
4	GND Earth		N/A
5	TTIP1	1	TX -
6	TRING1	1	TX +
7	GND Earth		N/A
8	GND Earth		N/A
9	RRING0	0	RX +
10	RTIP0	0	RX -
11	GND Earth		N/A
12	TRING0	0	TX -
13	TTIP0	0	TX +
14	TRING2	2	TX -
15	TTIP2	2	TX +
16	GND Earth		N/A
17	RRING2	2	RX+
18	RTIP2	2	RX-
19	GND Earth		N/A
20	TTIP3	3	TX-
21	TRING3	3	TX+
22	GND Earth		N/A
23	RTIP3	3	RX+
24	RRING3	3	RX-
25	GND Earth		N/A

4.2.5 Unbalanced Payload Data

For a later variant of the Indoor Unit, there is a set of 75 Ohm BNC's on the front panel.

- Rx implies IN (signal expected to go INTO the interface)
- Tx implies OUT (signal coming OUT of the interface)

4.2.6 Connecting Auxiliary In/Out (Optional)

The auxiliary in/out port is used to:

- Monitor switch-closure events using two isolated inputs.
- Control line connections using normally-open and normally-closed relay outputs.

Connect the port:

1. Assemble an auxiliary in/out cable using a 15 way D-type male connector according to connector pin assignments shown in Table 7.
2. Connect to the cable Indoor Unit auxiliary in/out connector.
3. Secure the connector using locking screws.

Table 7. Auxiliary In/Out Connector Pin Outs		
Indoor unit connector	Pin No	Signal
15-pin D-type female 	1	OUTPUT 1 COMMON
	2	OUTPUT 1 NORMALLY-OPEN
	3	OUTPUT 1 NORMALLY-OPEN
	4	OUTPUT 1 NORMALLY-CLOSED
	5	OUTPUT 1 NORMALLY-CLOSED
	6	OUTPUT 1 COMMON
	7	OUTPUT 2 COMMON
	8	OUTPUT 2 COMMON
	9	OUTPUT 2 NORMALLY-OPEN
	10	OUTPUT 2 NORMALLY-OPEN
	11	OUTPUT 2 NORMALLY-CLOSED
	12	INPUT 1
	13	INPUT 1 RETURN
	14	INPUT 2
	15	INPUT 2 RETURN

4.2.7 Connecting the Service (Wayside) Serial Channel (Optional)

This ‘clear’ serial channel can transport up to 115,200 bps across the radio link. This channel does not interfere with the payload data channels. The port is configured as DCE.

1. Connect the serial data interface cable to the Service channel connector on the Indoor Unit rear panel. The supplied serial data cable can be used to connect to this port after the software setup is completed.
2. See the table below for Indoor Unit connector pin assignments when a custom cable needs to be assembled.
3. Secure the connector using locking screws.

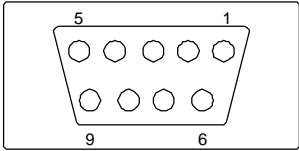
Service Channel Connector Pinouts		
Indoor Unit connector	Pin No	Signal
9-pin D-type Female Connector 	2	TD
	3	RD
	4	DTR
	5	GROUND
	6	DSR
	7	RTS
	8	CTS

4.2.8 Connecting the Element Manager Port

The Element Manager port is used to connect the Indoor Unit to a PC/Laptop serial port. This enables the Indoor Unit to be configured using the supplied NMS software or controlled via a PPP-dialup connection. The port can be connected to using the supplied serial data cable. The port is configured as DTE.

4.3 Outdoor Unit

Before installing the MDR Outdoor Unit, ensure that a suitable mast is used for the antenna and that the Outdoor Unit installation is firmly in position. The pole diameter must be between 50 and 102 mm.



CAUTION – ENSURE THAT THE POLE IS EARTHED FOR LIGHTNING PROTECTION.

4.3.1 MDR Outdoor Unit

Follow these steps to install the MDR Outdoor Unit:

1. Install the system antenna.
2. Adjust the mounting bracket to be slightly bigger than the pole diameter.
3. Secure the mounting bracket to the pole.
4. Secure the Outdoor Unit to the bracket using the screws on each bracket.
5. Connect the Outdoor Unit to the pole electrically by connecting the earth cable or strap between the pole earth and the Outdoor Unit earth point.
6. Connect the type-N RF output connector to the system antenna through an in-line lightning protection unit in areas with lightning activity.
7. Cover the connectors using an ultra violet protective, self-vulcanising tape.

4.3.1.1 RF Connection

1. The RF port is an N-type female connector.
2. The N-Type connector is used to connect to the antenna, typically using coaxial transmission line.
3. 1/2" or 5/8" coaxial cables are recommended. Coaxial cable that is 7/8" or larger can exhibit moding at 5.8 GHz and is not recommended for 5.8 GHz radios.
4. Do not use right angle N-type connectors with the radios: they may present high loss.
5. Do not use low quality cables. Some cable types, such as RG-8, may have too high a loss at 5.8 GHz.

4.4 Interconnection Cable Installation

Follow these steps to install the Indoor Unit to Outdoor Unit interconnection cables.



CAUTION

- **DO NOT OVER TIGHTEN THE CABLE STRAPS ON THE CABLES AND DO NOT FASTEN THE STRAP LOCKING MECHANISM OF THE CABLE STRAP ONTO THE CABLES.**

1. On the OU side, connect an RJ45 plug to the data cable. Place the RJ45 plug into the RJ45 socket in the Outdoor Unit connection box.
2. On the OU side, connect the DC power leads within the Outdoor Unit Connection Box. Use the +Ve and Return connections.

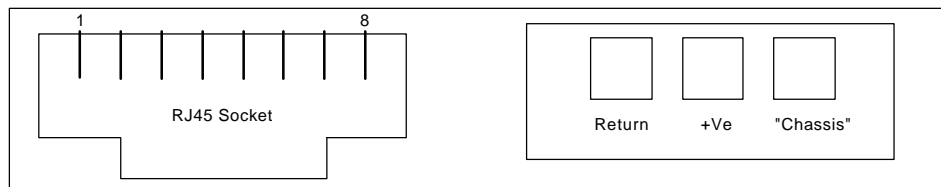

LOOKING AT THE REAR PANEL OF THE INDOOR UNIT

3. Close the Outdoor Unit Connection Box Cover using a 2.5mm Allen key. Make sure the rubber gaskets seal correctly over the power and data cables.
4. Using cable ties, secure the cable to the pole at regular intervals.
5. On the IU side, connect an RJ45 plug to the data cable. Place the RJ45 plug into the RJ45 socket in the rear of the Indoor Unit.
6. On the IU side, connect the DC power leads to the supplied GREEN Phoenix plug. Insert this plug into the green socket on the rear-panel of the IU.
7. The user can see that there is a suitable IU/OU data interconnection if the 'IU/OU Link' LED on the rear-panel of the IU is lit up green.



CAUTION

- **UNDO THE SCREWS OF THE "CONNECTION BOX" IN A UNIFORM MANNER. THIS ENSURES THAT THE "CONNECTION BOX" GASKET MATERIAL RELEASES STRESS UNIFORMLY AND DOES NOT LEAD TO THE SECURING SCREWS BEING BENT DUE TO THE PRESSURE PLACED ON THE CONNECTION BOX LID.**

4.4.1 INTERCONNECTION CABLE WIRING DESCRIPTION

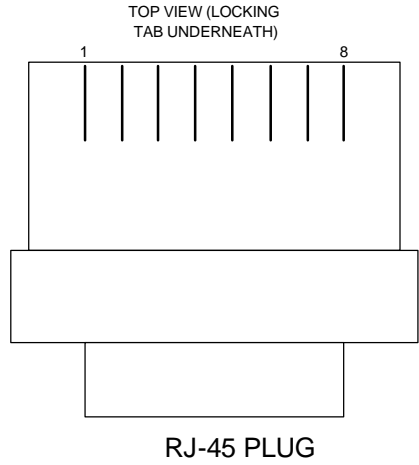

Pin	DTE (on INDOOR UNIT)	DCE (on OUTDOOR UNIT)	Wiring
1	TxD+	RxD-	Orange/White
2	TxD-	RxD+	White/Orange
3	RxD+	TxD+	Green/White
4†	TxC+	RxC+	Blue/White
5†	TxC-	RxC-	White/Blue
6	RxD-	TxD-	White/Green
7†	RxC+	TxC+	Brown/White
8†	RxC-	TxC-	White/Brown

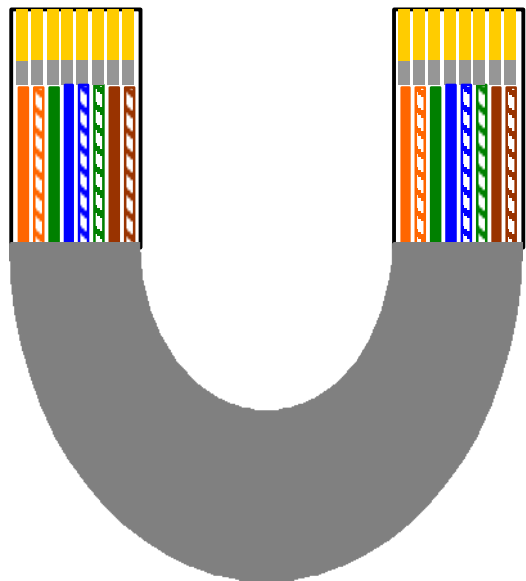

NOTE



† VERSION 1 AND 2 RELEASES OF THE HARDWARE (INDOOR AND OUTDOOR UNITS) CANNOT BE USED INTERCHANGEABLY. FOR VERSION 2 IU & OU HARDWARE, USE OF TxC+, TxC-, RxC+, RxC- **FALLS AWAY** AND ONLY TWO (2) TWISTED PAIRS ARE REQUIRED.

5 ANTENNA ALIGNMENT AND SOFTWARE SETUP

This chapter describes the procedure for software setup and antenna alignment. The setup is done with a PC running the supplied NMS software. See chapter 6 for details on using the NMS software.

5.1 Installation Equipment Required

The following tools and instruments are required for software setup and aligning the antenna:

- RSSI test cable
- Voltmeter
- Wrench / spanner (see appropriate details in installation chapter depending on the antenna being used)
- PC with NMS software and supplied serial data cable.
- Binoculars (optional) used for locating the far end site. This will assist in the antenna alignment operation.
- GPS or Standard Compass (optional) used for locating the far end site. This will assist in the antenna alignment operation.
- Bit Error Rate Tester and connecting leads.

5.2 Information Required

You should know:

- the proposed frequency channel plan for each station.
- the expected receive level based on the chosen system configuration and a path loss analysis.

5.3 Antenna Alignment

5.3.1 Introduction

The MDR OU should be installed on both sites before alignment starts. Perform the following steps at both stations:

1. Switch the Indoor Unit power ON.
2. Install and run the MDR NMS Software application.
3. Configure the radio channel plan as required.
4. Set the transmitted power to maximum.
5. Perform a RF loopback test at each site before starting the alignment procedure.

5.3.2 Alignment Procedure

1. Locate the far site and point the antenna to the antenna at the far site, as accurately as possible using binoculars or a compass.
2. Connect the multimeter to the RSSI connector on the Outdoor Unit using the supplied RSSI test cable and set the multimeter to measure volts.
3. Check the RSSI level and refer to the figure below for received power level.
4. Align the antenna until the maximum RSSI is attained.
5. Secure the antenna.
6. Measure the RSSI level and record the value (see section 5.7).
7. Compare with the value with that calculated for the link i.e. using the path loss calculation done when planning the link.

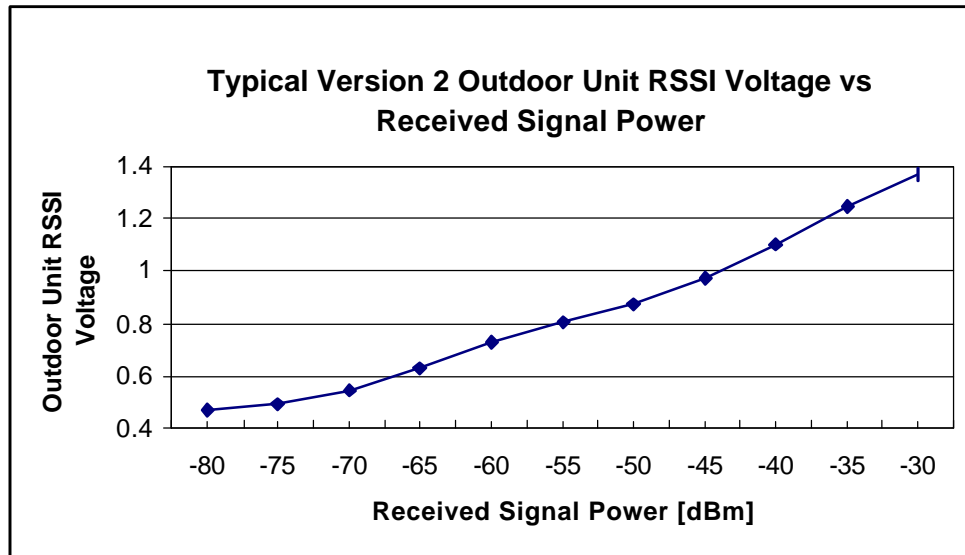

Figure 7. Typical Version 2 MDR5800 OU RSSI Voltage as a function of RF input power level

-80 dBm Average 0.436 ± 0.029 V : MIB RSSI 95 ± 1 dBm (see comment below)

-30 dBm Average 1.333 ± 0.047 V : MIB RSSI 54 ± 2 dBm (see comment below)

The MIB lists a dBm value representative of the received signal level. The value detected is representative of the level that would be measured should a CW signal be input at the Outdoor Unit's Diplexer RF Port - a Spread Spectrum signal will appear to be 20 dB lower. The NMS makes an adjustment for this by using a 20 dB offset (addition to the Indoor Unit MIB-indicated value).

The front panel RF Link LED, the Received Signal Strength Indicators (RSSI : on NMS, via SNMP or as an Electrical signal on the Outdoor Unit), Carrier-detect (NMS, SNMP) and Frame Lock (NMS, SNMP) indicators are available to assist with link installation and alignment.

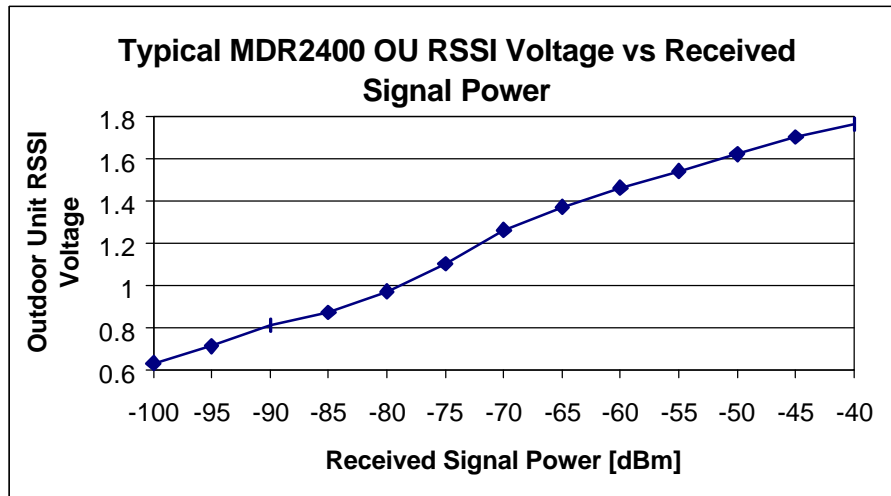

Figure 8. Typical MDR2400 OU RSSI Voltage as a function of RF input power level

5.3.3 Set Transmitted Power Level

It is good practice to match received power levels by adjusting transmitted powers if co-located systems are being installed. This is important to avoid interference between co-located systems. An attenuator can be fitted between the Outdoor Unit and the antenna if the power level cannot be sufficiently reduced. The dBm output at the OU N-type connector (socket) levels are set via the NMS or using a SNMP Management application.

5.4 Software Setup

Refer to chapter 6, for setting up the following:

- Payload interface.
- Service Channel (Wayside) serial port.
- Auxiliary in/out port.
- General link parameters.

5.5 Functional Test

After completing the physical installation of the Indoor Units, antennas, Outdoor Units and the interconnection cables, you need to commission the system. This procedure describes how to set up the minimum requirements for successful MDR system operation.

5.5.1 Link Bit Error Rate Performance Test

To start : when the link is setup correctly, the RF Link LEDs on both IUs on both sides of the RF link should be GREEN.

When the link has been setup and is running error-free:

1. Clear the Indoor Unit Log using Reset Button Position '2'
2. Clear the Indoor Unit Errors using Reset Button Position '1'

Perform a link bit error rate performance test as follows:

- Connect a bit error rate tester to the payload interface of the link.
- Run data over the link for a period of 24 hours.
- Record the BER.
- Record the LED statuses.

Check the Indoor Unit Packet Error Results via the NMS or via SNMP access to the Indoor Unit MIB – for the NMS, right-click on the antennas in the NMS for either side of the link and select the “Diagnostic/Error Monitor” option. Record the results by saving the data to a file. For SNMP access, use a MIB Browser and check the mdrmtcRFLinkPerf and mdrmtcG826 Performance groups.

Record all results on a test record. See MDR Test Record, section 5.7 for an example.

5.6 MDR Installation Record

Parameter	Unit	Site A	Site B
Site Name			
Antenna Type			
RF cable length	Meters		
Lightening protection unit	Yes/No		
Interconnecting cable length	Meters		
Outdoor Unit serial number			
Indoor Unit serial number			
Outdoor Unit earthed	Yes/No		
Indoor Unit earthed	Yes/No		
Power Supply	Volts DC/AC		

	Date	Name	Signature
Performed by			
Approved by			

5.7 MDR Test Record

Parameter	Unit	Site A	Site B
Frequency channel plan: Transmit Receive Note 1 : C is NOT used for the MDR2400. Note 2 : FCC requirements (U.S. only), page 2.	A/B/C/D A/B/C/D If D – List Transmit and Receive Frequencies [MHz]		
Transmitter output power (Note 2)	DBm		
Receiver input level (ON)	Volts		
Receiver input level (ON)	DBm		
Receiver input level (OFF)	Volts		
Receiver input level (OFF)	dBm		
Calculated input level	dBm		
Fade margin	dB		
Frame Lock indicator	Colour		
Fixed attenuator	dB		
BER-test	Hours BER		
Alarm Indicators	Clear (Yes/No)		

	Date	Name	Signature
Performed by			
Approved by			

This page is left blank intentionally.

6 NMS SOFTWARE

6.1 Introduction to the Network Management System

The purpose of the Network Management System, hereafter called the NMS, is to allow you to configure, manage or interrogate the following primary functional elements of a Digital Radio Link (Local or Remote Stations within the link):

- Indoor Unit
- Outdoor Unit

The NMS is a PC-based software package that provides you with a graphical interface that is used to perform on-site element management of a Microwave Digital Radio (MDR) System. It allows you to configure, manage and interrogate the MDR System by selecting various menus and options.

It provides extensive management functions on site and, via the microwave radio link, can be used to access the remote MDR station.

The hardware as well as the software constituting the NMS is collectively called the NMS Terminal.

The NMS Terminal is the principal system support equipment associated with the MDR System for system installation and commissioning.

It connects to a designated NMS Terminal port (labelled Element Manager) on the front panel of the Indoor Unit of a MDR Station installation, by means of a serial data interface (this cable is supplied in the IU box).

The NMS communicates with SNMP agent software that is contained in each MDR Indoor Unit. The NMS communicates with the agent's software: the software enables a unit to interpret MIB (Management Information Base) commands via SNMP (Simple Network Management Protocol).

6.2 General Information

1. To select a button/option, simply click the appropriate button/option.
2. Move the mouse pointer to the different areas of the screen. When the pointer changes into a hand, this indicates that the area can be activated by a left mouse button click. In some cases (opto inputs, relays, payload interfaces), hold the mouse hand cursor over the particular area of the screen and a hint appears indicating the state associated with the selected item. If the pointer changes to vertical bar, then the field may be edited if clicked.
3. The main screen has pull-down menus that are activated by clicking on the words of the menu (menu items).

4. A general help facility is available by clicking on the **Help** button on the **Main** screen. This opens the help file for the Network Management System. From here, you can search for a particular topic using the Index facility or you can use the Find facility to search for key words connected to the specific information required.

6.2.1 Microwave Digital Radio

A MDR link consists of at least one complementary pair of MDR stations that may be extended over longer distances by linking further station pairs in a multiple-hop configuration. A single MDR station comprises an Indoor Unit and an Outdoor Unit interconnected by a data cable (CAT5) and a 2-core DC supply cable.

6.3 Main Screen

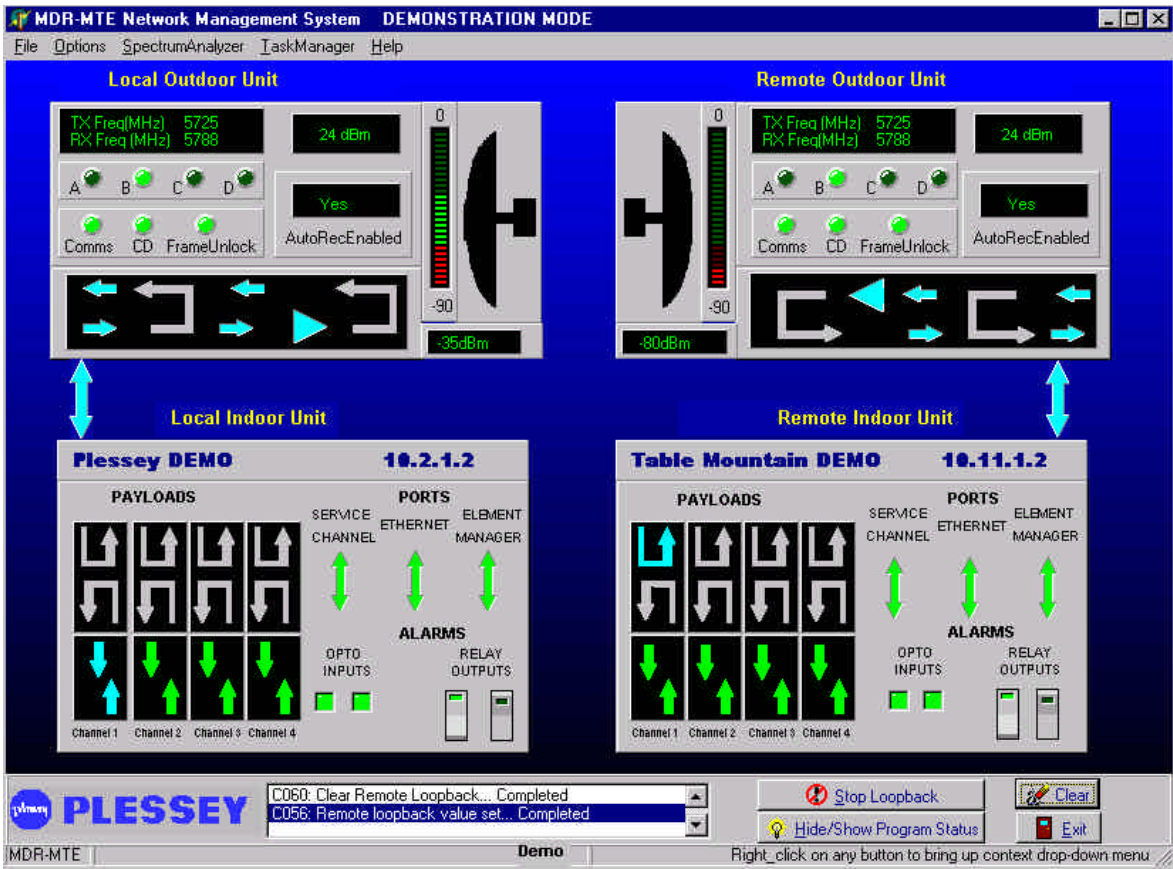

This screen displays the names of the stations/sites, their IP addresses and allows you to view or edit the parameters and status for the entire station. Indoor Unit and Outdoor Unit details are accessed by using the mouse to select the Indoor Unit and Outdoor Units of the local or remote sites.

Note that if the local Indoor Unit is offline, all controls for both station IUs and OUs are 'greyed out' and thus unavailable. If the Outdoor Unit is offline and the Indoor Unit is online, then only the Outdoor Unit controls are 'greyed out' and unavailable.

The Main screen shows a local station on the left hand side of the screen and a remote station on the right hand side of the screen.

The Main Menu area provides pull-down menus and controls that allow you to configure and monitor system link parameters and to perform basic tasks.

The station elements are displayed initially with no colours, but the controls in the blocks change colours when the NMS attempts to communicate with the link's primary elements.

The control buttons on the screen are short-cuts to MIB elements in the Indoor Units.

Move your mouse pointer to the required area of the screen and when the mouse pointer changes into a 'hand', click the right mouse button to display more detailed information. Click the left mouse button to activate relays and loopbacks.

6.3.1 Link Elements Areas

The Link Elements Areas on the Main Screen show an abbreviated status of the Indoor and Outdoor Unit interfaces. Move your mouse pointer to each block until a hand appears and click the right mouse button (right click) to see more information on each element.

If both Stations are online, the status bar at the bottom of the screen shows that the stations are being polled. If there is no communication with the remote side, the remote station will be greyed. If there is no communication with the local side's Outdoor Unit, it will be grey.

Display Indicators

- A **GREEN** status indicator shows that there are no current alarms or errors.
- A **YELLOW** status indicator shows that there was a historic alarm condition.
- A **RED** status indicator shows that there is a current alarm condition.

The main screen shows a **RSSI** (Received Signal Strength Indication) bar graph in dBm.

6.4 NMS Menus

6.4.1 Main Screen Menus

The following pull-down menus are available from the Main menu:

Menu	Sub-item	Result
File	Exit	Exit from NMS.
Options	Communications	Allows setup of which communications port is used on the PC or Laptop for communication with the Indoor Unit via the front panel Element Manager Serial Port.
	Local Trib Code	It is possible to purchase upgrades for E1/T1 Indoor Units (upgrades to 2E1/T1 or 4E1/T1). The user contacts the factory and provides the Indoor Unit Bar Code number details. The factory then supplies a "Tributary Code", unique to the Indoor Unit, which is entered using the MIB (Version 1 & 2 products) or using the NMS (Version 2 product).
	Remote Trib Code	See above.
	Local User Configuration	Allows the user to set the access control settings for the local station equipment to allow the user to log on as an 'Administrator' with full read/write configuration access or with 'Read-only' access. (Note: This option is only available if the IU firmware has been supplied with secure-features activated – the default is NOT to have this feature activated).
	Remote User Configuration	Allows the user to set the access control settings for the remote station equipment to allow the user to log on as an 'Administrator' with full read/write configuration access or with 'Read-only' access. (Note: This option is only available if the IU firmware has been supplied with secure-features activated – the default is NOT to have this feature activated).
Spectrum Analyzer		Allows the user to examine the RF spectrum using a RSSI (received signal strength indicator) value measured in the Outdoor Unit. If interference exists, this feature allows the user to examine the spectrum and decide where to set the transmit and receive frequencies for the local and remote stations.

6.4.1.1 Exiting from the NMS : File/Exit

You can exit from the NMS as follows:

Click on the **Exit** option from the **File** pull-down menu on the **Main** screen.

You are prompted for confirmation of the shutdown – answer **OK** or **Cancel** to this prompt.

6.4.1.2 Communications

This menu item allows you to configure the following NMS communications parameters:

- Serial Port
- Polling Cycle

The users can either:

Use the **Load Defaults** option or change to the required settings and then use the **Apply Changes** button.

Use the **Exit** button to exit without any changes being made.

6.4.1.2.1 Serial Port

Configure the serial port as follows:

1. Select **Communications** from the menu on the main screen.
2. Select the required port: **COM1**, **COM2**, **COM3** or **COM4**.

6.4.1.2.2 Polling Cycle

Set the polling cycle (minimum 3 seconds). This determines how often the information is updated.

6.4.1.3 Local User Configuration

Allows the user to set the access control settings for the local station equipment to allow the user to log on as an 'Administrator' with full read/write configuration access or with 'Read-only' access (only available with "security-enabled" versions of Indoor Unit firmware).

The user enters a 'Username', 'Password', 'Access level' and activates the user via an 'Active' input field.

With 'Administrator' access, the user can add new users.

Use the **Apply Changes** button once the changes are to be made in the Indoor Unit.

Use the **Exit** button to exit without any changes being made.

6.4.1.4 Remote User Configuration

As above, but controls access to the remote station's MIB.

6.4.2 Main Screen Short-cut Buttons

Short-cut buttons are provided to allow quick access to the above menu items.

6.5 Indoor Unit Configuration

The Indoor Units have graphical interface controls that allow you to configure the following items:

- Payload Data Interface Port
- Service Channel Port
- 'Loopback to Line' and 'loopback to RF Link'
- Opto Inputs
- Relays

Payload is from the user's 'line' equipment to the Indoor Unit Payload Data DB25 connector and **RF Link** is from Antenna to Antenna.

Right click on the Indoor Unit to get the following options

- Time/date entry
- Station Status
- Station Properties
- Station Info (Serial number, software version, bootkernel version)
- View Event Log
- Maintenance

6.5.1 Controls

6.5.1.1 Payload Data Interface Port

A label/name can be assigned to any of the payloads.

6.5.1.1.1 E1 Port Line Code

Default setting is **HDB3**. However, it can be set to either **HDB3** or **AMI**.

6.5.1.1.2 T1 Port Line Code

Default setting is **B8ZS**. However, it can be set to either **B8ZS** or **AMI**.

6.5.1.2 Payload Error Monitoring

Term	Name	Description
AIS	Alarm Indication Signal	This is an all 1's detection, incoming to the equipment on the payload tributaries. Note that there is independent monitoring for AIS on each of the 4 tributaries.
LOS	Loss of Signal	This is a loss of signal detected on the input to the payload data port tributaries. Note that there is independent monitoring for LOS on each of the 4 tributaries.

6.5.1.3 Service Channel Port

The service channel serial port provides a means to send asynchronous data across the link to the far side service channel port. Service channel ports can be connected back-to-back (i.e. Remote to Local) at a remote site so as to extend the channel in a multi-hop network. The service channel data is multiplexed with IP data onto the RF overhead link. Priority is given to IP data.

Use the **Load Defaults** option or change to the required settings and then use the **Apply Changes** button.

Use the **Exit** button to exit without any changes being made.

6.5.1.3.1 Baud Rate

Default setting is **115200 bit/s (Ver 1, 2)**.

6.5.1.3.2 Data Width

Default setting is **8 bits**.

6.5.1.3.3 Parity

Default setting is **None**.

6.5.1.3.4 Flow Control

Default setting is **None**.

6.5.1.3.5 Stop Bits

Default setting is **1 Bit**.

6.5.1.4 Relay Scripting (NA for Version 1, 2 releases)

Configure the various alarms that will switch on Indoor Unit relays as required. There are two relays on each Indoor Unit. Each relay can be programmed to switch on based on the occurrence of Payload or RF Link errors detected in the LOCAL/NEAR and/or REMOTE/FAR Indoor Units. The user can visually select those errors that will trigger the respective relays.

The following built-in test status can be monitored on a link:

RF Link	Link Unavailable
	Frame Unlock
	Minor PER Exceeded
	ESR Exceeded
Payload Interface	LOS
	AIS

Use the **Apply Changes** button to change settings.

Use the **Exit** button to exit without any changes being made.

6.5.1.5 Indoor Unit Loopback Controls

These controls allow you to set the loopbacks on the payload data.

- **IU Loopback to Line** - Used to loopback the data on the payload interface so that incoming user payload data is sent straight back to the user. The payload data does not go out over the RF link.
- **IU Loopback to RF Link** - Used to loopback the payload (Indoor Unit)/Outdoor Unit data so that payload data arriving over the RF link is looped and sent back across the RF link.

Perform a loopback as follows:

1. Select the Loopback Type by choice of arrows on the IU being tested.
2. Select the Loopback Timeout **Time** (in seconds). If enabled, the Loopback state will cancel after Time seconds and the unit will return to normal operation.
3. Click on the Loopback Timeout **Enable** checkbox.
4. Click on the **Apply Changes** button.

6.5.2 Menu Items

6.5.2.1 Date/Time Entry

In his menu, the user has the option of entering the:

- Date (change date using the calendar display)
- Time (change time using the spin button on the right-hand side of the control or enter manually).
- The user had the option of 'fetching' the date and time from the PC or Laptop and using this information.
- Use the **Apply Changes** button once the update in the Indoor Unit is to be made.

6.5.2.2 Station Status

6.5.2.3 General Status Indicators

These errors occur during the phase of continuous error checking. Errors are latched until the operator clears them on the NMS.

The following is a list of possible error indicators as well as the possible faults and corrective actions to solve each error.

Error Displayed	Possible Faults and Corrective Actions
General Faults	
Outdoor Unit Not Responding	<ul style="list-style-type: none"> The Outdoor Unit simply doesn't respond to any messages sent to it by the Indoor Unit. The Outdoor Unit could possibly be damaged or the cables to the Outdoor Unit are disconnected from the Indoor Unit or damaged.
Outdoor Unit Comms Error	<ul style="list-style-type: none"> Message from Outdoor Unit too long (data corruption). Received message frame invalid – the Outdoor Unit messages follow a strict data link layer frame protocol. There could data corruption. Partial message received from Outdoor Unit - remainder did not arrive in time (Outdoor Unit switched off?). CRC Error – data corruption. Software queuing/buffering errors in the Indoor Unit firmware.
Wayside Port Comms Error	<ul style="list-style-type: none"> Wayside port queue overruns - too high data rates or failed overhead link. Comms Error - errors caused by Rx Overrun (Indoor Unit processor could not service the received characters fast : too high data rates), parity error if odd or even parity enabled (data corruption or incorrect configuration), framing error (no valid stop bit where one was expected - invalid baud rate or data width or parity configuration or data corruption) or break detected (line shorted causing permanent break or corruption).
Overhead Link Comms Error	<ul style="list-style-type: none"> Overhead PPP link error: the buffering system of the overhead link cannot process data fast enough and received messages have been discarded (the software cannot process the data fast enough).
Ethernet Comms Error	<ul style="list-style-type: none"> The buffering system of the interface cannot process data fast enough and received messages have been discarded (the software cannot handle the data fast enough).
Element Manager Comms Error	<ul style="list-style-type: none"> Message from PC or laptop too long (data corruption). Software queuing/buffering errors in the NMS firmware.
Alarm 1 on	A digital optically isolated input used for general site alarm monitoring (Auxiliary Input 1).
Alarm 2 on	A digital optically isolated input used for general site alarm monitoring (Auxiliary Input 2).

6.5.2.3.1 Power-up Self Test Indicators

The following is a list of errors that can occur during the power-up phase of operation. These errors may only be cleared by switching the Indoor Unit off and then on again. The list also describes the possible faults and corrective actions to solve each error.

Error	Possible Faults and Corrective Actions
FLASH	The Application FLASH memory test failed. Only a faulty Application Flash device can cause this fault and the Application Flash device will have to be replaced.
DRAM Error	The DRAM test failed. Only a faulty DRAM device can cause this fault and the DRAM will have to be replaced.
SRAM Error	The battery-backed up SRAM test failed. Only a faulty SRAM device or battery can cause this fault and the Battery and/or SRAM will have to be replaced.
Watchdog Reset	Software error. Please contact the supplier. Processor triggered a watchdog restart because watchdog is no longer being toggled by the application. Either the application has become too overloaded or this is a software or design fault.
Hard Reset	A hardware reset was performed. This is an indication of the last reason for a reset and does not constitute a fault condition.
Unknown Reset	Another reset detected by the Indoor Unit's microprocessor (other than Watchdog and Hard Reset) was performed. This is an indication of the last reason for a reset and does not constitute a fault condition.
Line Interface Error	The line interface transceiver is not responding as expected and is most likely faulty. The transceiver is programmed for operation and then checked to see that the values programmed are valid (read correctly).
FPGA	The FPGA register interface is not responding correctly and is most likely faulty. The FPGA is programmed for operation and then checked to see that the values programmed are valid (read correctly).
Real Time Clock	The Real Time Clock (RTC) is not responding correctly and is most likely faulty. The RTC is programmed for operation and then checked to see that the values programmed are valid (read correctly).

Use the **Clear** button to clear alarm indicators.

6.5.2.4 Station Properties

In this menu, the user has the option of entering the:

- Indoor Unit Station name
- IP address of the Indoor Unit
- Netmask

Use the **Apply Changes** button once the update in the Indoor Unit is to be made.

6.5.2.5 Station Info

This information allows you to view the build state details of the primary hardware and software components of the selected Indoor Unit. Information provided is read from the Indoor Unit microprocessor.

Serial Number (Programmed into the Indoor Unit at time of manufacture),

Software Version (Programmed into the Indoor Unit during any software upgrade) and

Bootkernel Version Number (Programmed into the Indoor Unit at time of manufacture).

6.5.2.6 Indoor Unit Event Log

This screen is used for the viewing of the event log file. In the event of a persistent field fault it will be useful for you to save the logged data file and send it, with the faulty unit, to the repair department to assist in the repair of the unit. There is a maximum of 100 records stored in the Indoor Unit (one filled, earlier records are discarded in favour of newer records). The event log file is displayed from oldest to youngest i.e. ascending order by time. The log file columns are:

Date – the date of the event dd-mm-yyyy.

Time – the time of the event in hh:mm:ss.

Type – the type of event.

Event – a text description of the event itself.

Use the **Clear Log** button to clear the log in the Indoor Unit.

Use the **Refresh** button to collect the log from the Indoor Unit.

Use the **Save** button to save the log on the NMS PC or Laptop platform.

Use the **Exit** button to exit the Event Log menu.

6.5.2.7 Maintenance

This screen provides the ability to upgrade the Indoor Unit firmware on the local/near Indoor Unit only.

The user selects the file to be uploaded using the 'Select File' button. A file selection dialogue is presented which provides a means to retrieve the file from any directory on any drive.

Once the file is selected, the following information is displayed on the screen:

Application version - the Indoor Unit application code software version number as read from the Indoor Unit application).

Date and time - the Indoor Unit application code software date as read from the Indoor Unit application.

Bootkernel version - the Indoor Unit boot kernel code software version number as read from the boot kernel.

Upload Status box

Used to display the steps being undertaken during the programming and verification process. As the upload process proceeds, the user is informed of progress. Verification of upload is done once the file has been uploaded into DRAM. Thereafter the data is loaded into 'Application Flash'. The latest version is uploaded into one ½ of the flash device. The other half maintains the old version. In this way, there is an option to revert to the old version should there be an upload problem.

6.5.2.7.1 Programming an Indoor Unit

This procedure allows you to program factory-supplied firmware into the Application Flash IC on the Indoor Unit. Proceed as follows:

1. Switch off the Indoor Unit. Run the NMS application and connect to the Indoor Unit via the Element Manager Port.
2. Select the file to be uploaded into the Indoor Unit.
3. Switch on the Indoor Unit.
4. The upload process will proceed and the user is informed of the progress via the status box.
5. Once complete, the IU verifies the program code is valid.
6. Once verified, the data is transferred into the IU's Application Flash.
7. Once the code is programmed, the Indoor Unit application is restarted by the boot kernel.

6.6 Outdoor Unit Configuration

6.6.1 Controls

6.6.1.1 Loopback Controls

These controls allow you to set the loopbacks on the payload data.

- **OU Baseband Loopback** - Used to loopback the data at baseband processor level in the Outdoor Unit so that incoming user payload data is sent back to the user via the IU/OU interconnection data cable.
- **OU RF Loopback** - All RF data sent out of the Local Indoor Unit to the Outdoor Unit is looped back at the output stage of the Outdoor Unit and returned to the Indoor Unit.

Perform a loopback as follows:

1. Select the Loopback Type by choice of arrows on the OU being tested.
2. Select the Loopback Timeout **Time** (in seconds). If enabled, the Loopback state will cancel after Time seconds and the unit will return to normal operation.

3. Click on the Loopback Timeout **Enable** checkbox. If not enabled, then only the NMS can cancel the loopback condition.
4. Click on the **Apply Changes** button.

6.6.2 Menu Items

6.6.2.1 Station Configure

The current Outdoor Unit parameters for Channel plan, Transmit Power and Autorecovery are displayed. All Outdoor Unit operational parameters are stored in the Indoor Unit. The Outdoor Unit is unaware of what it has been programmed to do. The operational parameters are programmed automatically after a power up.

This screen allows you configure the following **Operational** Outdoor Unit parameters:

- Frequency channel Plan.
- Transmit Power.

6.6.2.1.1 Frequency Channel Plan

The MDR5800 Radios operate in the 5.725 GHz to 5.850 GHz ISM frequency band. The MDR5800 has predefined frequency channel plans (termed A, B, C and D).

The MDR2400 Radios operate in the 2.400 GHz to 2.4835 GHz ISM frequency band. The MDR2400 has predefined frequency channel plans (termed A, B and D).

Note : FCC requirements for the MDR2400, page 2.

6.6.2.1.2 Transmit Power

The Transmit power ranges from 2 to 24 dBm. There is also a mute setting.

Note : FCC requirements for the MDR2400, page 2.

6.6.2.1.3 Auto-recovery

This feature is used if the user is installing a link from one side and there is no technical staff assistance on the opposite side of the link. It mitigates against the link failing and not being able to be re-established.

If auto-recovery is enabled, the required operational RF parameters are programmed into the Outdoor Units by the local and remote Indoor Units. If communication between the two Indoor Units has not reactivated within 5 seconds, the previous (working) 'default' RF parameters are programmed into the respective Outdoor Units.

6.6.3 OU Station Info

The OU Station Info screen provides a brief report of the build state of the Outdoor Unit:

- Serial number – loaded into the Outdoor Unit at time of manufacture.
- Software version – loaded into the Outdoor Unit at time of manufacture.
- High Band Transmitter – affects the way the channel plan is implemented on the Outdoor Unit.
- Low Band Transmitter – affects the way the channel plan is implemented on the Outdoor Unit.
- FCC Regulations (None, FCC, Other).

6.6.4 Outdoor Unit Status

This screen allows you to view the following Outdoor Unit status information:

- **Last Restart.** This indicates the reason why the Outdoor Unit restarted, e.g. Power On, Watchdog Timeout.
- **OU Lock Detect Status:** indicates if there is a loss of lock of the IF, Transmit or Receive path phase-locked oscillators in the OU.

6.7 RF Link Error Status Monitoring

Selected by right-clicking the relevant antenna and choosing the Diagnostics/Error option.

6.7.1 RF Link Status

Link Unavailable	The RF Link is considered not available (see Link Availability definition on next page).
Frame Unlock	RF link only. It looks at data received from the link. If the link is quality is poor, i.e. high PER at the RF level, 'Frame Unlock' is the result. AIS is sent from the transceiver (from link direction) as long as 'Frame Unlock' is true and no reliable data is available.
Packet Error Rate Fault	The PER Monitoring has been enabled and the Instantaneous PER has exceeded the configured PER Fault Threshold for the RF link.
ESR Exceeded	RF Errored Second Ratio has been exceeded due to Packet errors on the RF link.
SESR Exceeded	RF Seriously Errored Second Ratio has been exceeded due to Packet errors on the RF link.
BBER Exceeded	RF Background Block/Packet Errors Ratio has been exceeded due to block errors on the RF link.

Default RF Parameters Activated

The Operational RF parameters were programmed into the Outdoor Unit by the local and remote Indoor Units. Communication between the two Indoor Units has not reactivated within 5 seconds. To recover communication the Indoor Unit has selected the 'Default' RF parameters and programmed the Outdoor Unit with them.

6.7.2 Packet Error Rate Thresholds

Packet error rate (PER) is calculated as the ratio of the number of uncorrectable blocks over the number of blocks transmitted per second. Three PER thresholds are provided for each monitored link, these are:

- **Minor PER Threshold** – this threshold defaults to 0.0002 and triggers an alarm if the calculated PER exceeds this value.
- **Major PER Threshold** – this threshold defaults to 0.02 and triggers an alarm if the calculated PER exceeds this value.
- **Fault PER Threshold** – this threshold defaults to 2.0 and triggers an alarm if the calculated PER exceeds this value.

6.7.2.1 G.826 Thresholds

Three G.826 thresholds are provided for each monitored link. Each of these ratios is calculated once every second and will trigger a fault condition if the ratios exceed the programmed thresholds that are:

- **Errored Second Ratio Threshold** – this threshold which defaults to 4×10^{-2} triggers an alarm if the calculated ESR exceeds this value over the measurement period (Report Time).
- **Severely Errored Second Ratio Threshold** – this threshold which defaults to 2×10^{-3} triggers an alarm if the calculated SESR exceeds this value over the measurement period (Report Time).
- **Background Block Error** – this threshold which defaults to 6.25×10^{-2} triggers an alarm if the calculated BBER exceeds this value over the measurement period (Report Time).

6.7.2.2 Link Availability

A period of unavailable time begins at the onset of ten consecutive SES events. These ten seconds are considered to be part of unavailable time. A new period of available time begins at the onset of ten consecutive non-SES events. These ten seconds are considered to be part of available time. The figure below illustrates this definition.

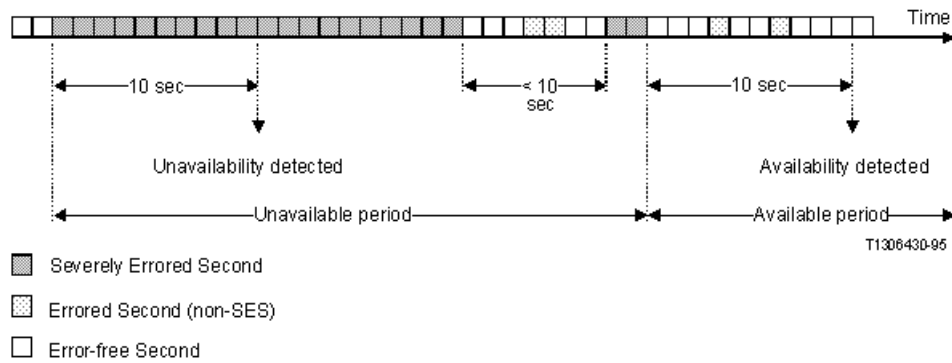

6.7.3 RF Link Error Monitor

The Link Error Monitor screen provides the user with detailed Packet Error Rate (PER), G.826 and link availability monitoring for the RF link. There is a status field, Total Seconds, which applies to the link. Total Seconds is the total number of seconds since the counts were last cleared. It is used to determine available and unavailable seconds on a link.

6.7.3.1 General

- **Errored Blocks Counter** - containing the number of blocks containing errors accumulated until cleared.
- **Errored Seconds Counter** - containing the number of seconds containing errored blocks since the counters were last cleared.
- **Severely Errored Seconds Counter** - a counter containing the number of seconds containing more than 30% errored blocks since the counters were last cleared.
- **Background Block Errors Counter** - a counter containing the number of blocks received in error excluding those contributing to severely errored seconds since the counters were last cleared.
- **Error Second Ratio** – a ratio of the number of Errored seconds to the total number of seconds since the counters were last reset.
- **Severely Error Second Ratio** – a ratio of the number of Severely Errored seconds to the total number of seconds since the counters were last reset.
- **Background Block Error Ratio** – a ratio of the number of Background Blocks in errors to the total number of blocks received since the counters were last reset.
- **Corrected Symbols** field shows the number of symbols that have been corrected by the FEC device within the Indoor Unit.

6.7.3.2 Packet Error Rate

- **Instantaneous Ratio** - This is the number of errored blocks as determined by the FEC on the RF Link, divided by the total number of blocks per second for

that link. If the instantaneous PER exceeds the minor or major PER thresholds, a fault is triggered and a RF Link error is indicated on the Indoor Unit Front Panel.

- **Maximised Ratio** - The highest Packet error rate reached since the errors were last cleared.

6.7.3.3 Link Availability

- **Available Seconds** – the number of seconds the link has been available since counts were last cleared.
- **Unavailable Seconds** – the number of seconds the link has been unavailable since counts were last cleared.

This page is left blank intentionally

7 MAINTENANCE INFORMATION

1. The user is advised to refer to the Technical Data section for details on IU/OU interconnection cables (customer-furnished).
2. The "Ordering Information" paragraph in the Technical Data section provides details on part numbers for items that can be ordered.
3. Section 4 of this manual lists customer furnished equipment that should be used for installing the MDR product.
4. There are two options to control the MDR products via SNMP.
 - a. One uses any open-standard-compliant SNMP Management package (HP OpenView, SNMPc etc): in this case, one has access to the full compliment of the product's MIB elements.
 - b. The NMS application package supplied with the product accesses a subset of the MIB. It has a graphical user interface carefully designed to assist installation and maintenance staff.

This page is left blank intentionally

8 TECHNICAL DATA

8.1 Environmental Requirements

8.1.1 Outdoor Equipment

Operating temperature:	-30°C to +60°C
Relative humidity:	8-100%
Atmospheric pressure:	0.7 to 1.06 kPa
Lightning protection	ITU-T K.20

8.1.2 Indoor Equipment

Operating temperature:	0°C to +50°C
Relative humidity:	5-90%
Lightning protection:	ITU-T K.20

8.2 Mechanical Information for Outdoor Equipment

8.2.1 MDR2400 and MDR5800 Outdoor Unit

Dimensions (HxWxD):	335mm x 231mm x 124mm
Weight:	5.9 Kg

8.3 Mechanical Information for Indoor Equipment

Dimensions (HxWxD):	45mm x 480 mm x 265mm
Mounting:	19" Rack, 1U high or Table top
Weight:	2.9 Kg

8.4 Power Supply Requirements

DC power supply:	21 to 56 VDC
DC power supply grounding:	Positively or negatively grounded
Power consumption:	35 W typical, 45 W maximum.

8.5 Electrical Performance

8.5.1 General Characteristics

MDR2400

Frequency Range:	2400 to 2483.5 MHz
Data Capacity:	E1 (2048 Mbps), T1 (1544 Mbps/s) 2E1 : 2T1 4E1 : 4T1
RF Channel Bandwidth:	17 MHz
Go/Return spacing:	Can be adjusted as fixed go-return spacing is NOT mandatory in the ISM licence-free bands.
Modulation:	CCK
Processing Gain:	11 dB
Frequency Channel Plan A:	2410 and 2460 MHz
Frequency Channel Plan B:	2426 and 2476 MHz
Transmission Delay:	600 us maximum for radios only (one-way)

MDR5800

Frequency Range:	5725 to 5850 MHz
Data Capacity:	E1 (2048 Mbps), T1 (1544 Mbps/s) 2E1 : 2T1 4E1 : 4T1
RF Channel Bandwidth:	17 MHz
Go/Return spacing:	Can be adjusted as fixed go-return spacing is NOT mandatory in the ISM licence-free bands.
Modulation:	CCK
Processing Gain:	11 dB
Frequency Channel Plan A:	5735 and 5804 MHz
Frequency Channel Plan B:	5753 and 5822 MHz
Frequency Channel Plan C:	5771 and 5840 MHz
Transmission Delay:	600 us maximum for radios only (one-way)

8.5.2 Transceiver Characteristics

8.5.2.1 Frequency Band: MDR2400 Lowband Outdoor Units

Transmit band: 2410 – 2426 MHz

Receive band: 2458 – 2474 MHz

8.5.2.2 Frequency Band: MDR2400 Highband Outdoor Units

Transmit band: 2458 – 2474 MHz

Receive band: 2410 – 2426 MHz

8.5.2.3 Frequency Band: MDR5800 Lowband Outdoor Units

Transmit band: 5725 – 5787 MHz

Receive band: 5787 – 5850 MHz

8.5.2.4 Frequency Band: MDR5800 Highband Outdoor Units

Transmit band: 5787 – 5850 MHz

Receive band: 5725 – 5787 MHz

8.5.3 RF Interface

Transmitted Power	+2 to +24 dBm, software adjustable (incl. mute)
Receiver Sensitivity:	4E1/4T1 : -88dBm for PER = 10^{-6} (2400) -86dBm for PER = 10^{-6} (5800)
Maximum Receive Level:	-30dBm

8.5.4 Payload Data Interfaces

8.5.4.1 1, 2 or 4 (i.e. nE1) Interface

Data Rate:	Full duplex E1 (2.048Mbit/s), 2E1 or 4E1
Digital Interface:	ITU-T G.703
Connectors:	Balanced 110 ohm on DB25 Unbalanced 75 ohm on BNC's (later variant of IU)
Line code:	HDB3 or AMI selectable
Jitter and Wander:	ITU-T G.823

8.5.4.2 1, 2 or 4 (i.e. nT1) Interface

Data Rate:	Full duplex T1 (1.544Mbit/s), 2T1 or 4T1
Digital Interface:	DSX-1, G.703 compliant
Connectors:	Balanced 110 ohm on DB25 Unbalanced 75 ohm on BNC's (later variant of IU)
Line code:	AMI or B8ZS selectable
Jitter and Wander:	ITU-T G.823

8.5.5 Auxiliary Input Interface (CONTACT CLOSURE)

Number of Inputs:	2
Maximum voltage:	12V
Logical zero:	Short from input to return pin
Logical one:	Open input to return pin

8.5.6 Auxiliary Output Interface

Number of outputs:	2
States:	Normally-open and normally-closed
Contact rating:	DC: 220 V, 1 A, 60 W AC: 250 V, 1 A, 125 VA

8.5.7 Wayside channel interface

Interface standard:	RS232, DCE
Handshaking:	None, Hardware
Port rate:	115,200 bps

8.5.8 Element Manager Port Interface

Interface standard:	RS232, DTE
Handshaking:	Hardware
Data rate:	115,200 bps

8.5.9 Indoor/Outdoor Unit Interface

The physical interface between the Indoor and Outdoor Unit is IEEE802.3 Ethernet. As such, the same considerations that apply between standard routers/switches/hubs and PC LAN cards should be adhered to when selecting lengths of cables between the OU and the IU. Cable lengths of up to 120 meters have been tested in a laboratory environment.

The following table lists information to assist the user to select cables to be used between the Indoor and Outdoor Units.

Interconnecting cable	
Data	
<u>South Africa</u> STP (FTP) 4 Pairs Solid Cat 5, PVC FR UV protected Polifin H2/J263/904 Outer Black. Outer diameter of cable : 7.3mm ± 0.5mm. (this is an “upjacketed” STP 4 Pair cable).	This is a standard FTP Cat 5 cable that is ‘upjacketed’ with suitable plastic for FR/UV (Flame retardant/Ultra Violet) protection.
Other cables: <ol style="list-style-type: none"> 1. Superior Essex BBDN CAT 5 cable P/N 04-0010-34 (7.8mm) 2. Superior Essex CAT 5 P/N 18-241-31 18-241-11 (5.1mm) 3. General Cable CAT 5 P/N 2137113 2137114 (5.6mm) 4. Belden CAT 5 P/N BC1002 (6.0mm) <p>Option 1 is the preferred choice. For the cables that have diameters less the required OD, one can use one or two pieces of heatshrink on the cable where it passes through the gasket.</p>	
Interconnecting cable	
Power	
<u>South Africa</u> Power 1.5mm sq stranded PVC Insulated, PVC FR UV protected Polifin H2/J263/904 Outer Black 300/500V Temp -20°C to +85°C. Cable outer diameter: between 7.4mm and 9mm i.e. 8.2mm ± 0.8mm.	
Other cables: <p>Superior Essex type SJOOW flexible cable P/N 441821* (7.4mm)</p> <p>Carol Cable (General Cable) SJOW/SJO P/N 02001 18 gauge 2 conductor (7.8mm)</p>	

8.6 Ordering Information

Part No	Model Number	Description
651-03853ET1HB or 651-03853ET1LB	MDR5800-ET1	MDR5800 Radio: Indoor Unit and High or Low Band Outdoor Unit, Type-N RF output, high power output for FCC and unregulated, Full E1/T1, 2Mbps or 1.5Mbps data interface
651-03853ET2HB or 651-03853ET2LB	MDR5800-ET2	MDR5800 Radio: Indoor Unit and High or Low band Outdoor Unit, Type-N RF output, high power output for FCC and unregulated, Full 2xE1/2xT1, 2x2Mbps or 2x1.5Mbps data interface
651-03853ET4HB or 651-03853ET4LB	MDR5800-ET4	MDR5800 Radio: Indoor Unit and High or Low band Outdoor Unit, Type-N RF output, high power output for FCC and unregulated, Full 4xE1/4xT1, 4x2Mbps or 4x1.5Mbps data interface

The MDR5800 operates from 21-56VDC, optional 110-220VAC power supply available below. A complete link requires two radios, one must be High Band (HB) and the other a Low Band (LB).

Part No	Model Number	Description
651-03994ET1HB or 651-03994ET1LB	MDR2400-ET1	MDR2400 Radio: Indoor Unit and High or Low Band Outdoor Unit, Type-N RF output, high power output for FCC and unregulated, Full E1/T1, 2Mbps or 1.5Mbps data interface
651-03994ET2HB or 651-03994ET2LB	MDR2400-ET2	MDR2400 Radio: Indoor Unit and High or Low band Outdoor Unit, Type-N RF output, high power output for FCC and unregulated, Full 2xE1/2xT1, 2x2Mbps or 2x1.5Mbps data interface
651-03994ET4HB or 651-03994ET4LB	MDR2400-ET4	MDR2400 Radio: Indoor Unit and High or Low band Outdoor Unit, Type-N RF output, high power output for FCC and unregulated, Full 4xE1/4xT1, 4x2Mbps or 4x1.5Mbps data interface

The MDR2400 operates from 21-56VDC, optional 110-220VAC power supply available below. A complete link requires two radios, one must be High Band (HB) and the other a Low Band (LB).

Accessories & Upgrades

Part Number	Description
651-03864	Bench Power Supply 110-220VAC to 48VDC
651-03865	MDR Upgrade 1xE1/T1 to 2xE1/T1
651-03866	MDR Upgrade 2xE1/T1 to 4xE1/T1
651-03867	MDR Upgrade 1xE1/T1 to 4xE1/T1

The MDR systems use standard CAT5 Ethernet cable and RJ-45 connectors for connecting the Indoor Unit to the Outdoor Unit. A two-wire power cable is also required between the Indoor Unit and the Outdoor Unit. Note Screened Cat5 cable and UV resistant cables are recommended for long term outdoor use.

Microwave Digital Radio System Spare Parts for MDR2400 and MDR5800

Part Number	Description
651-03810ET1	MDR MTE Indoor Unit 1xE1/T1 - Spare Part
651-03810ET2	MDR MTE Indoor Unit 2xE1/T1 - Spare Part
651-03810ET4	MDR MTE Indoor Unit 4xE1/T1 - Spare Part
651-04008ET1	MDR MTE 75/120 OHM Indoor Unit 1xE1/T1 - Spare Part
651-04008ET2	MDR MTE 75/120 OHM Indoor Unit 2xE1/T1 - Spare Part
651-04008ET4	MDR MTE 75/120 OHM Indoor Unit 4xE1/T1 - Spare Part
651-03806LB	MDR5800 Low Band Outdoor Unit - Spare Part
651-03806HB	MDR5800 High Band Outdoor Unit - Spare Part
651-03905LB	MDR2400 Low Band Outdoor Unit - Spare Part
651-03905HB	MDR2400 High Band Outdoor Unit - Spare Part
651-03868	MDR NMS Software Disk - Spare Part
651-03809	MDR OU Pole Mounting Kit - Spare Part
862-01881	MDR Digital Radio System User Manual - Spare Part
660-03405	MDR Cable Assembly: RSSI Test Loom - Spare Part

MDR5800 Ordering Information:

Part no's:

1E1/T1 Radio: 651-03853ET1HB or 651-03853ET1LB

2E1/T1 Radio: 651-03853ET2HB or 651-03853ET2LB

4E1/T1 Radio: 651-03853ET4HB or 651-03853ET4LB

Each **MDR5800** radio includes the following:

Part No	Description	QTY
651-03810ET1 or 651-03810ET2 or 651-03810ET4	MDR MTE Indoor Unit: 1xE1/T1 or 2xE1/T1 or 4xE1/T1	1
651-03806HB or 651-03806LB	MDR5800 Outdoor Unit	1
651-03809	MDR 5800 ODU Pole Mounting Kit	1
862-01881	MDR Digital Radio System User Manual	1
651-03868	NMS Software Disks	1
660-03405	RSSI Cable	1

It is possible to purchase upgrades for E1/T1 Indoor Units (upgrades to 2E1/T1 or 4E1/T1). The user contacts the factory and provides the Indoor Unit Bar Code number details. The factory then supplies a "Tributary Code", unique to the Indoor Unit, which is entered using the MIB (Version 1 & 2 product) or using the NMS (Version 2 product).

MDR2400 Ordering Information:

Part no's:

1E1/T1 Radio: 651-03994ET1HB or 651-03994ET1LB

2E1/T1 Radio: 651-03994ET2HB or 651-03994ET2LB

4E1/T1 Radio: 651-03994ET4HB or 651-03994ET4LB

Each **MDR2400** radio includes the following:

Part No	Description	QTY
651-03810ET1 or 651-03810ET2 or 651-03810ET4	MDR MTE Indoor Unit: 1xE1/T1 or 2xE1/T1 or 4xE1/T1	1
651-03905HB or 651-03905LB	MDR2400 ET4 Outdoor unit	1
651-03809	MDR 5800 ODU Pole Mounting Kit	1
862-01881	MDR Digital Radio System User Manual	1
651-03868	NMS Software Disks	1
660-03405	RSSI Cable	1

It is possible to purchase upgrades for E1/T1 Indoor Units (upgrades to 2E1/T1 or 4E1/T1). The user contacts the factory and provides the Indoor Unit Bar Code number details. The factory then supplies a "Tributary Code", unique to the Indoor Unit, which is entered using the MIB (Version 1 & 2 product) or using the NMS (Version 2 product).

9 APPENDIX A: ELEMENT MANAGER PORT POINT-TO-POINT SERIAL COMMUNICATIONS SETUP

This appendix summarises how to set up a network connection (using PPP) between a computer and the MDR Indoor Unit's Element Manager port. It lists how the connection can be setup and configured to allow data transfer and SNMP-based control of the MDR Indoor Unit.

Note : For both NT and Win 95 or 98 machines, check that a Network Adapter is installed.

The following screen capture shows the Windows help available to assist setting up a serial comms network adapter.

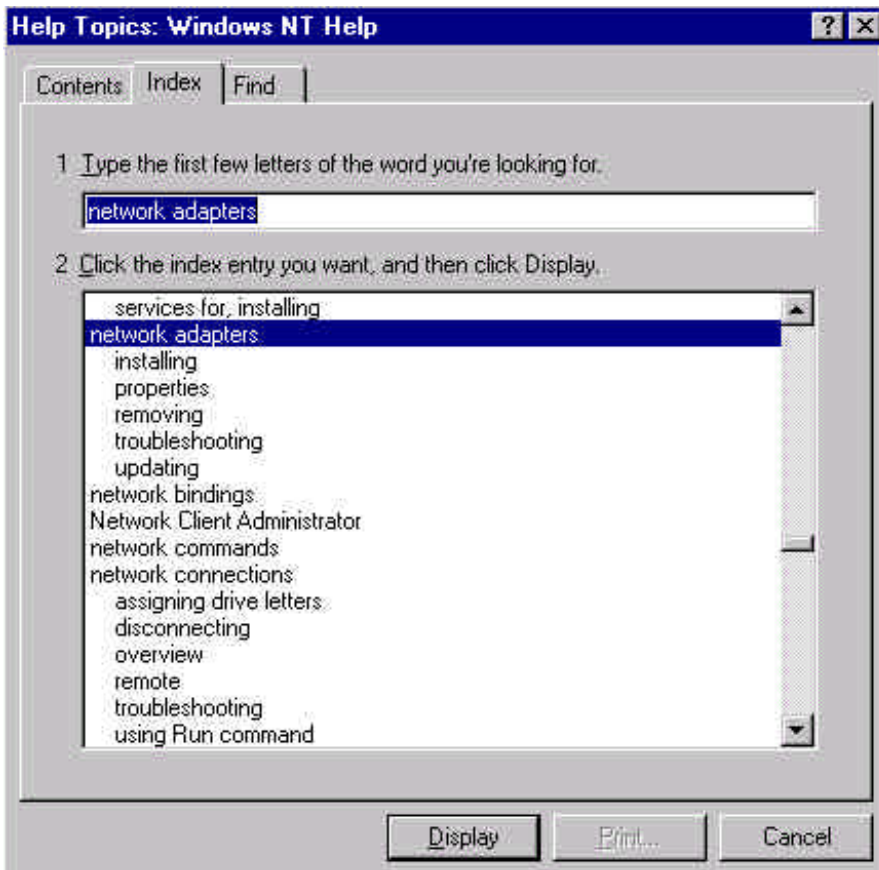

9.1 Adding a Modem : Windows NT

1. When working with a PC running a Windows NT, add a modem using the following screen as a guideline.



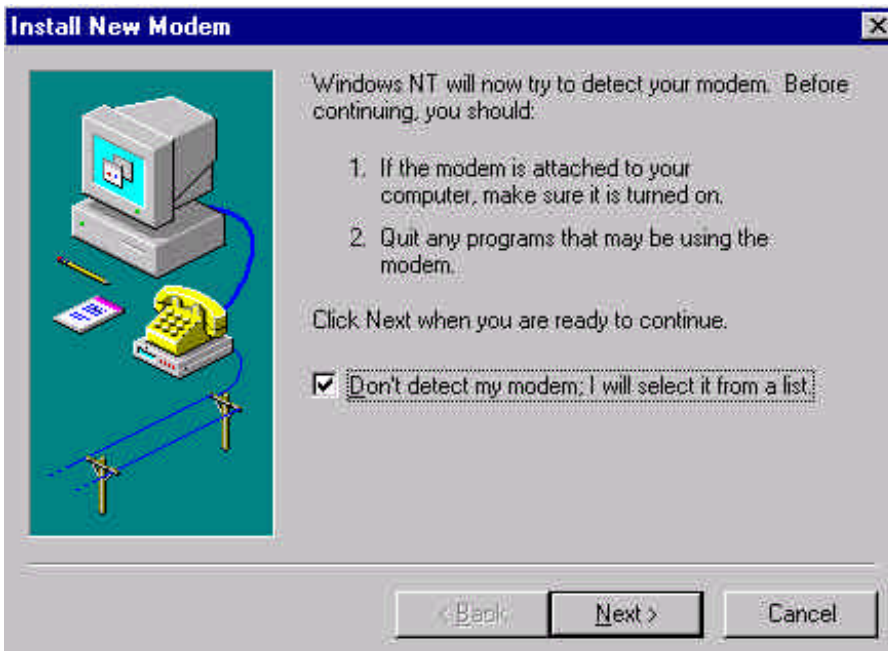
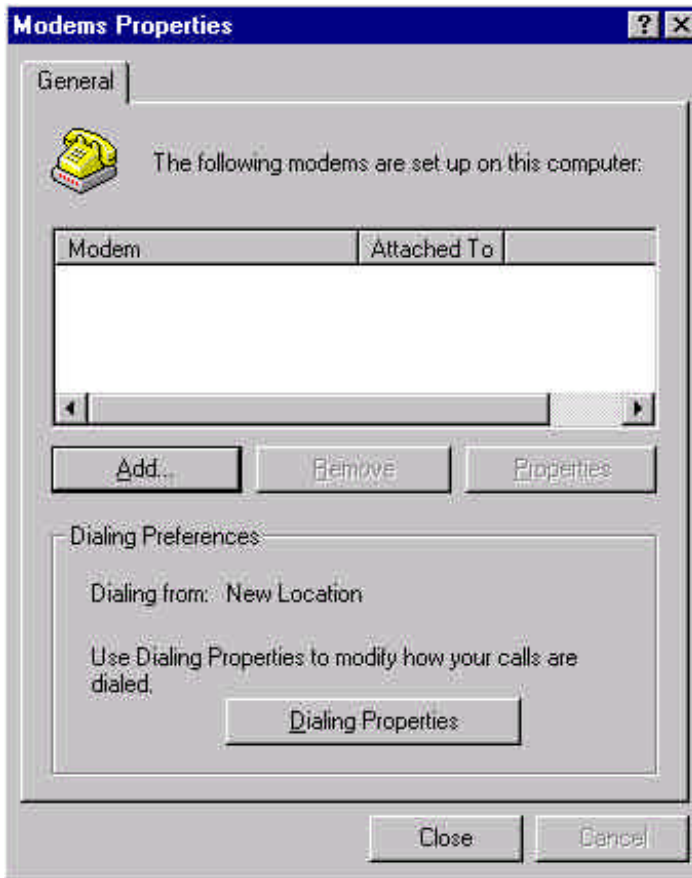

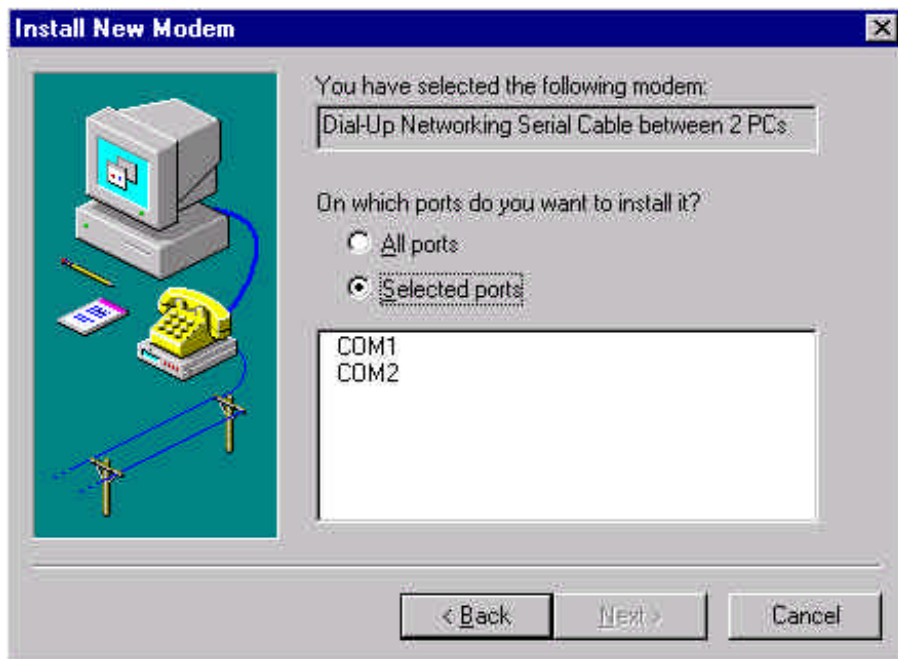
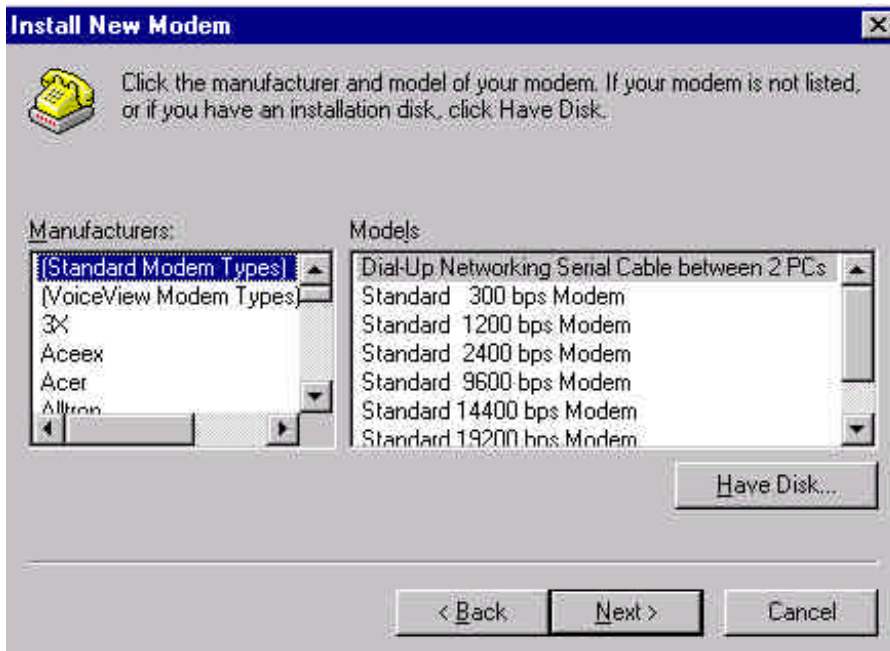

2. Select the COM port to use – push the Next when the COM port has been selected.



9.2 Adding Dial-up Networking : Windows NT

9.2.1 To add dial-up networking

1. From the desktop, open the My Computer icon and double-click the **Dial-up Networking** icon.

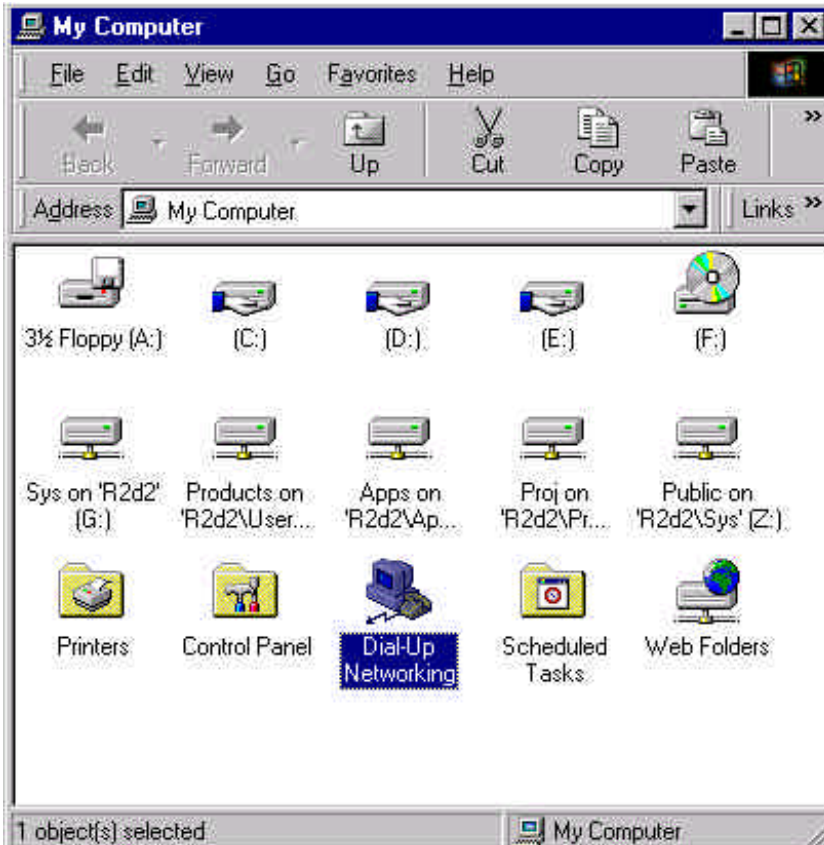

2. The following windows are displayed:

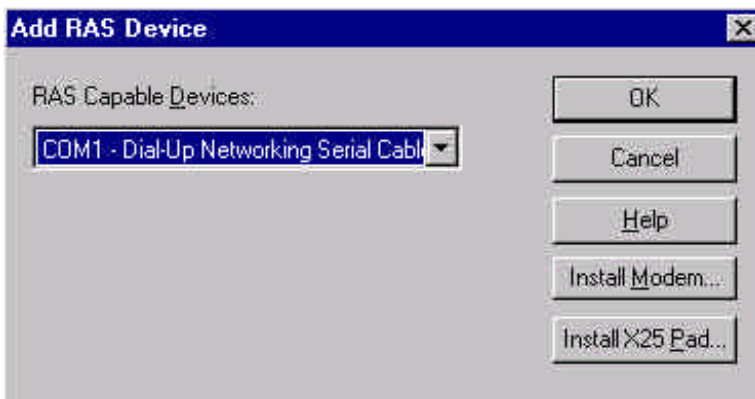

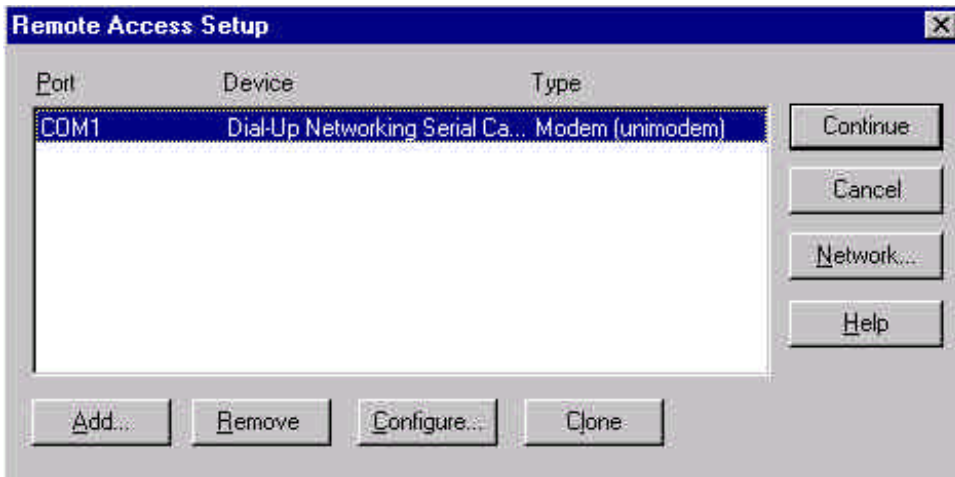

- Whether COM1 or COM2 is selected, setup the connection using the following screens as a guideline. This allows establishment of a PPP connection between the computer and the MDR Indoor Unit's Element Manager port.

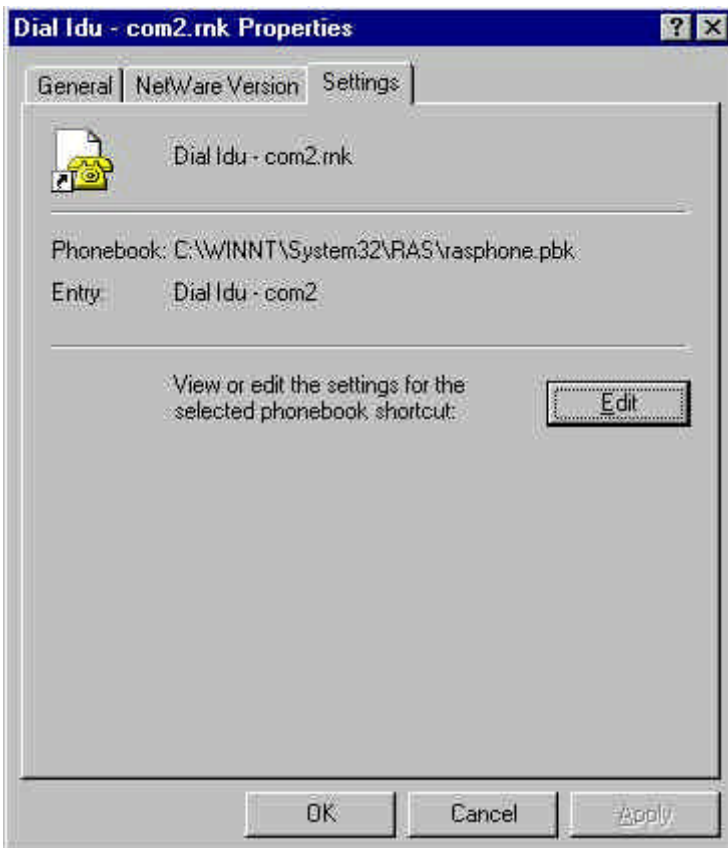

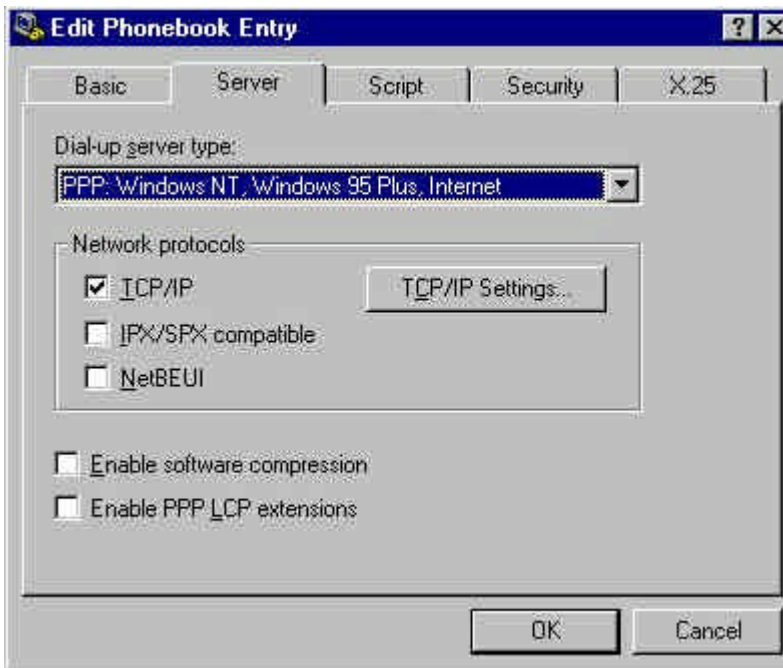
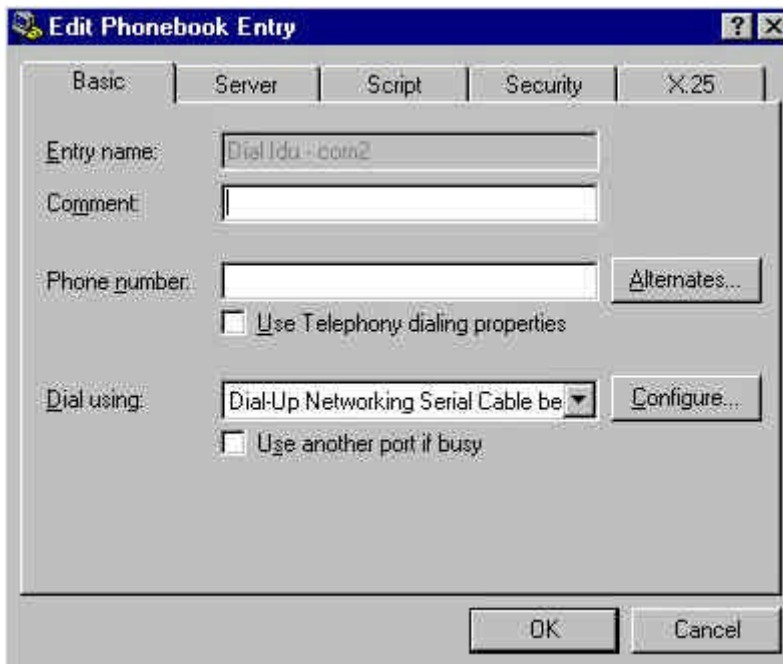



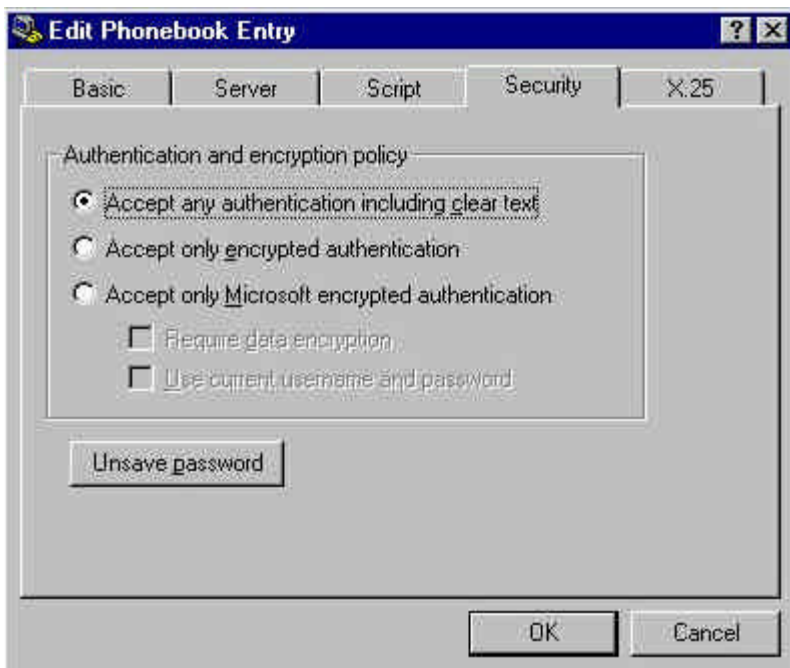

9.3 Adding a Modem : Windows 95/98

1. When working with a PC running a Windows 95/98, add a modem using the following screen as a guideline.

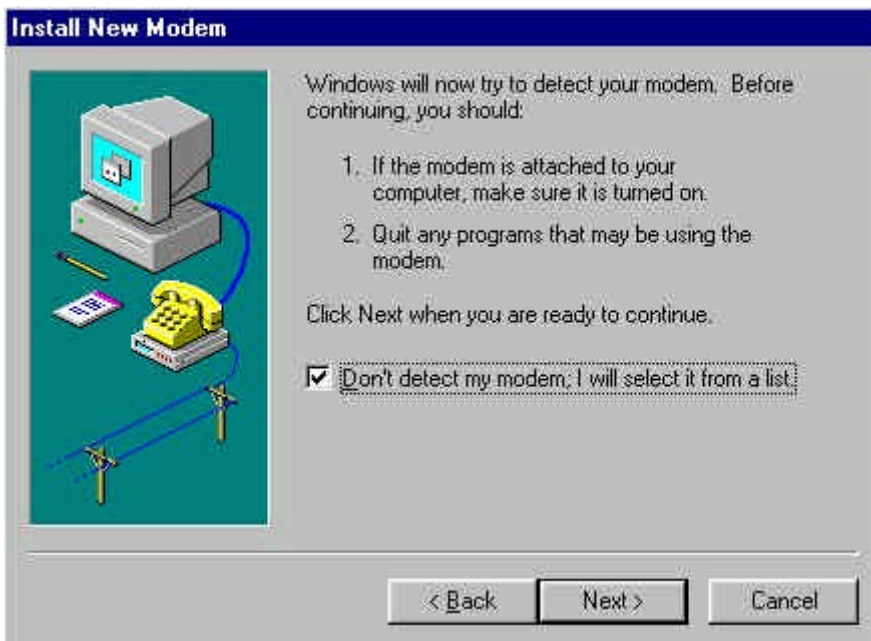

3. Use the mdmnull.inf to add a serial cable modem connection capability to the PC or laptop.

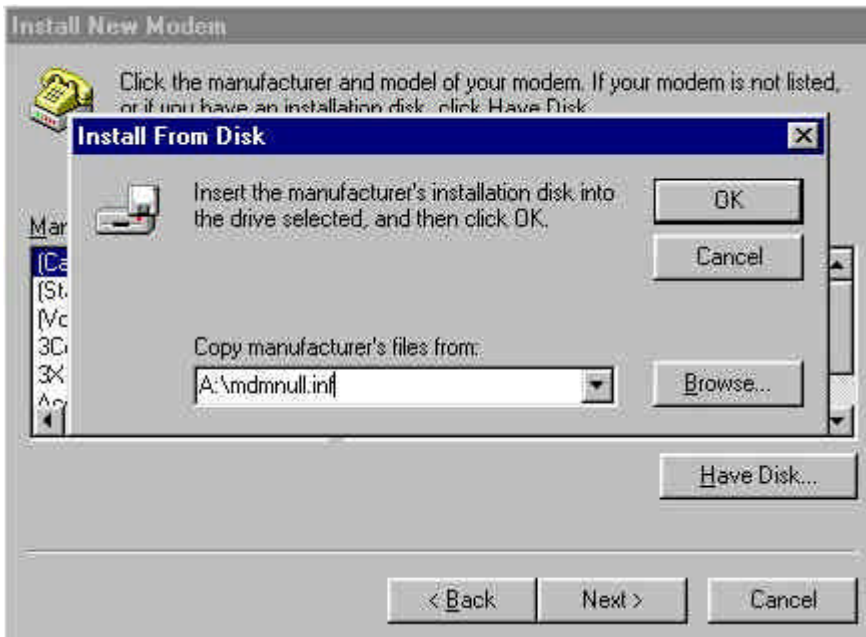

4. Once setup, use the following screens to set up the COM port's parameters.

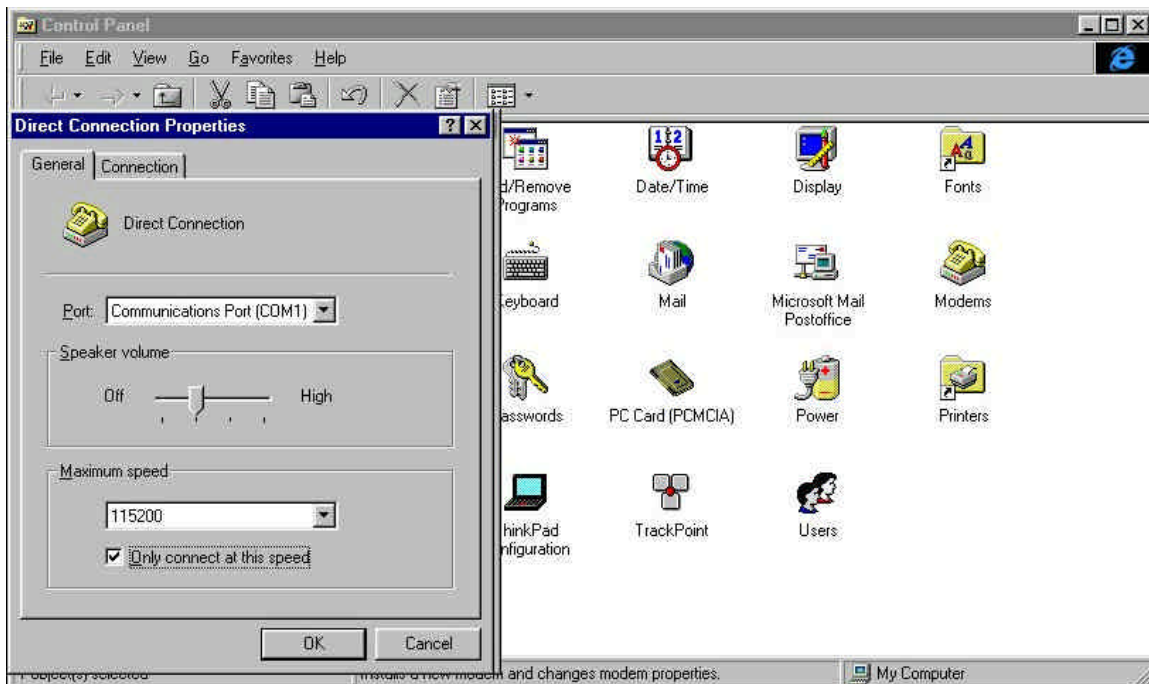

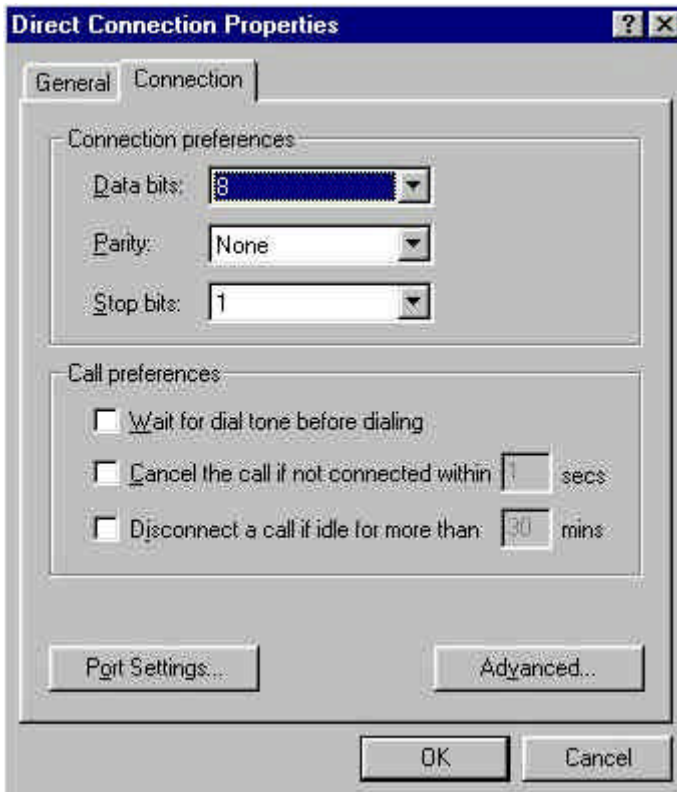

9.4 Adding Dial-up Networking : Windows 95/98

1. After adding the modem, set up the connection properties using the following screens as a guideline. This will allow establishment of a PPP connection between the computer and the MDR Indoor Unit's Element Manager port. A Null_Modem connection option as shown below will be created. If one doesn't exist, double click on the "Make New Connection" icon.

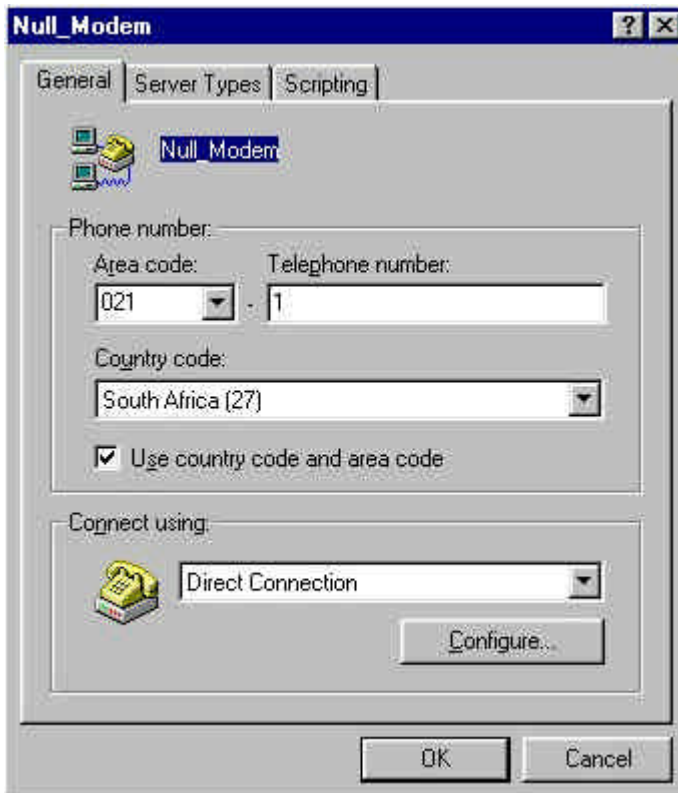
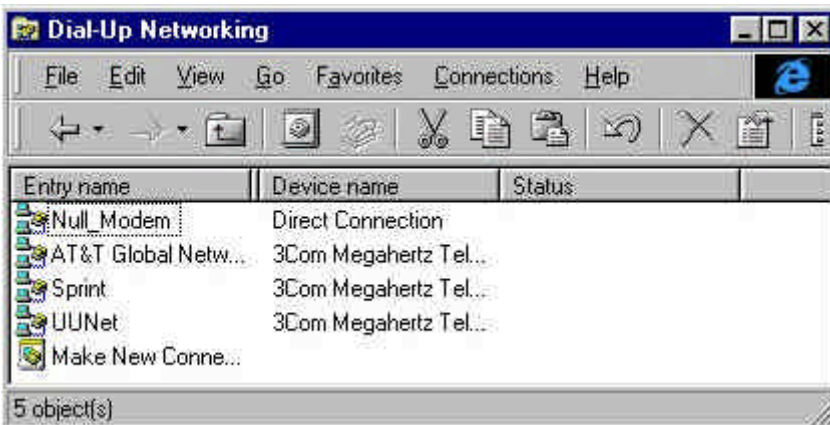

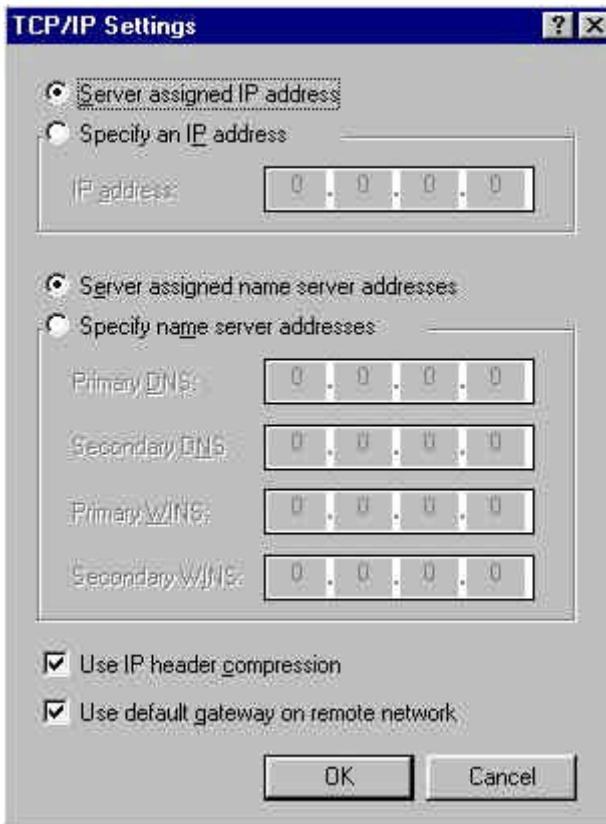
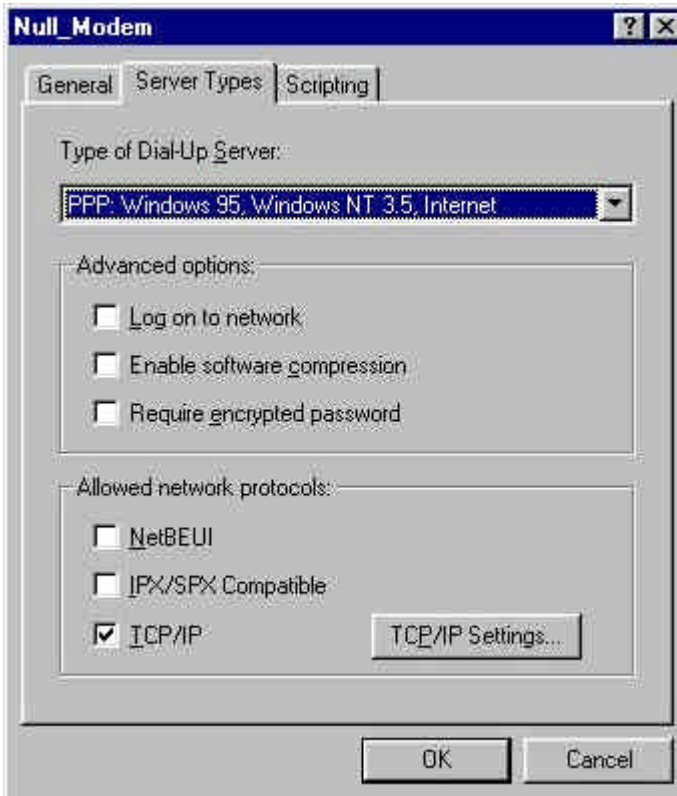

10 APPENDIX B: MANAGEMENT OF THE MDR2400 AND MDR5800

All management of the MDR product is implemented using SNMP (Simple Network Management Protocol), an open standard. The MDR product can be managed by:

1. Standard SNMP managers such as HP OpenView or SNMPc i.e. there is Open Network Management compatibility.
2. For rapid product installation, the NMS GUI Application (hereafter referred to as the NMS-GA) provides extensive management functions on site and, via the microwave radio link, can be used to access the MDR station on the opposite side of the link. The MDR NMS-GA is a software application that runs on a PC workstation such as a laptop or notebook computer that is connected to an MDR Indoor Unit (IU) serial port (DB9 DTE) or an Ethernet connection (10BaseT DTE) (both accessed via the IU front-panel).

10.1 SNMP and the MDR

Use of SNMP within the product allows remote: configuration, monitoring of performance, notification of alarms and firmware upgrades via an IP-network. Within an IP network supporting routing of IP data, the radios can be supported from any remote location. The product can be accessed via the Internet if the necessary gateways are provided. A GSM/PCS modem dial-up capability provides another remote management option.

The MDR Indoor Units have built-in SNMP agents and an extensive MIB (Management Information Base). The MDR product uses SNMP V1 (RFC1155, 1157). The user has access to an Enterprise MIB (obtainable through customer services) and MIB II (RFC 1213).

Access to the MIB via the IU SNMP agent is via Ethernet (10BaseT interface on the product's front panel) or PPP (RFC 1661) via the product's serial channel Element Manager port. The use of SNMP provides flexibility for operators with central equipment monitoring. It provides management access to radio configuration (all data interfaces), interface status and statistics, fault and maintenance information.

SNMP security (if enabled) is ensured by using a login and password to give the user administrator or basic user rights (a standard user rights option limits the ability to SET MIB variables).

The product has threshold-based alarm generation (there is an extensive SNMP trap list with a trap filter that is adjustable via SNMP). Network access (wired or wireless i.e. GSM/PCS Modem) allows over-the-air remote firmware uploading (FTP) with a load verification (and reversion) capability.

There are three principle requirements to use SNMP with the MDR Radio Stations.

1. A Management Station that runs a SNMP Management Software package that is installed on a networked or stand-alone PC that can be connected to an Indoor Unit either using a serial connection or an Ethernet connection. From the Management station, the agents within the MDR Indoor Units can be configured or polled for information.
2. Agent: The agent accepts SNMP GET, SET or GET-NEXT commands from the Management Application software and collects or adjusts information from the Indoor Unit's MIB.
3. Management Information Base (MIB): the MIB is a database that is accessed based on the OID (object ID) the SNMP Manager has chosen. The MDR Indoor Unit used an Enterprise MIB and a standard MIB (MIB II) to store or allow access to information relevant to the MDR Link.

10.2 The MIB Elements – OID (Object ID) DESCRIPTIONS

Object ID	Group	Object Type	Access	Description
1	Iso			
1.3	Org			
1.3.6	dod			
1.3.6.1	internet			
1.3.6.1.4	private			
1.3.6.1.4.1	enterprises			
1.3.6.1.4.1.1316	plessey			
1.3.6.1.4.1.1316.1	products			
1.3.6.1.4.1.1316.1.1	digitalradio			
1.3.6.1.4.1.1316.1.1.1	mdrmt			
1.3.6.1.4.1.1316.1.1.1.1	mdrmtPerformance			
1.3.6.1.4.1.1316.1.1.1.1.1	mdrmtPayloadPerf			
1.3.6.1.4.1.1316.1.1.1.1.1.1	mdrmtPpTable	SEQUENCE		
1.3.6.1.4.1.1316.1.1.1.1.1.1.1	mdrmtPpEntry	SYNTAX		
1.3.6.1.4.1.1316.1.1.1.1.1.1.1.1	mdrmtPpIndex	INTEGER		
1.3.6.1.4.1.1316.1.1.1.1.1.1.1.2	MdrmtPpLOS	INTEGER	read-only	A Loss of Signal has been detected on the input to a tributary - there are four, one for each tributary.
1.3.6.1.4.1.1316.1.1.1.1.1.1.1.3	MdrmtPpAIS	INTEGER	read-only	An Alarm Indication Signal has been detected on the input to a tributary - there are four, one for each tributary.
1.3.6.1.4.1.1316.1.1.1.1.1.2	mdrmtCrcErrors†	INTEGER	read-only	"The number of CRC4 or CRC6 errors seen on the selected tributary since the last time errors were cleared."
1.3.6.1.4.1.1316.1.1.1.1.1.3	mdrmtCrcTribSelect†	INTEGER	Rd-Write	"The tributary selected for CRC checking."
1.3.6.1.4.1.1316.1.1.1.1.1.4	mdrmtCrcLock†	INTEGER	read-only	"Indication of whether the CRC checking algorithm has locked onto a CRC frame signature in the payload data."
1.3.6.1.4.1.1316.1.1.1.1.1.5	MdrmtCrcEbit†	INTEGER	read-only	"Reflects the status of the 'E' bits in the frame."
1.3.6.1.4.1.1316.1.1.1.1.2	mdrmtRFLinkPerf			
1.3.6.1.4.1.1316.1.1.1.1.2.1	mdrmtCarrierDetect	INTEGER	read-only	Indicates if a RF Carrier has been detected by Outdoor Unit – if so, the header in the RF Packet has been identified as a potential valid packet - note however, that it could be received from another transmitter that uses the same

Object ID	Group	Object Type	Access	Description
				header format.
1.3.6.1.4.1.1316.1.1.1.1.2.2	MdmrteRSSI † ²	Gauge	read-only	A dBm value representative of the received signal level. The value detected is representative of the level that would be measured should a CW signal be input at the Outdoor Unit's Diplexer RF Port - a Spread Spectrum signal will appear to be 20 dB lower. The NMS makes an adjustment for this by using a 20 dB offset (addition to the Indoor Unit MIB-indicated value).
1.3.6.1.4.1.1316.1.1.1.1.2.3	mdrmteCurrentPER	DisplayString	read-only	This is the current Packet Error Rate and is based on the number of uncorrectable packets/blocks being detected by the FEC (Forward Error Correction) circuitry within the Indoor Unit (based on the number of errored packets divided by the total number of packets transmitted in a measurement period of 250msec).
1.3.6.1.4.1.1316.1.1.1.1.2.4	mdrmteMaximizedPER	DisplayString	read-only	This is the maximum Packet Error Rate detected during the last measurement period, based number of maximum number of uncorrectable packets/blocks detected by the FEC circuitry within the Indoor Unit.
1.3.6.1.4.1.1316.1.1.1.1.2.5	mdrmteLinkUnavailable	INTEGER	read-only	Based on G.826 criteria, this MIB element indicates RF Link Availability/Non-availability.
1.3.6.1.4.1.1316.1.1.1.1.2.6	mdrmteFrameUnlock	INTEGER	read-only	The data that is transmitted across the RF Link is conveyed in a frame, compiled within the Indoor Unit's FPGA. The received data frame is examined to see that the frame, with a suitable format has been received.
1.3.6.1.4.1.1316.1.1.1.1.2.7	mdrmteRemoteFrameUnlock†	INTEGER	read-only	Frame-lock (mdrmteFrameUnlock) as seen by the other end of the link is fed back here.
1.3.6.1.4.1.1316.1.1.1.1.2.8	MdmrteErrSecRatioExceeded	INTEGER	read-only	The ESR is a ratio of the number of Errored seconds (one second periods within which uncorrectable packets were counted by the FEC IC) to the total time in seconds.
1.3.6.1.4.1.1316.1.1.1.1.2.9	mdrmteSevErrSecRatioExceeded	INTEGER	read-only	The SESR is a ratio of the number of Severely Errored seconds (one second periods within which 30% of packets over the RF Link had uncorrectable errors) to the total time in seconds.
1.3.6.1.4.1.1316.1.1.1.1.2.10	mdrmteBkgndBlkErrRatioExceeded	INTEGER	read-only	The BBER is a ratio of the number of uncorrectable blocks/packets received to the total number of packets received.
1.3.6.1.4.1.1316.1.1.1.1.2.11	MdmrteMinorPERExceeded	INTEGER	read-only	This parameter indicates if the minor packet (uncorrectable by FEC) error rate has been exceeded based on the defined threshold listed in the mdrmtFAULT - mdrmtPerfTrapThreshold group.

² † indicates Version 2.00 MIB additions/name changes

Object ID	Group	Object Type	Access	Description
				A GH filter is applied to the calculation. This GH filter functions as a weighted average where the GH Average Filter Fraction is the proportion of the instantaneous PER used in the current seconds calculation. The remainder (1-Fraction(0.7)) is taken from the previous 250 millisecond calculation.
1.3.6.1.4.1.1316.1.1.1.1.2.12	mdrmteMajorPERExceeded	INTEGER	read-only	This parameter indicates if the major packet (uncorrectable by FEC) error rate has been exceeded based on the defined threshold listed in the mdrmtFAULT - mdrmtPerfTrapThreshold group.
1.3.6.1.4.1.1316.1.1.1.1.2.13	mdrmteCriticalPERExceeded	INTEGER	read-only	This parameter indicates if the critical packet (uncorrectable by FEC) error rate has been exceeded based on the defined threshold listed in the mdrmtFAULT - mdrmtPerfTrapThreshold group.
1.3.6.1.4.1.1316.1.1.1.1.2.14	mdrmtePrevParamsRestored	INTEGER	read-only	Indicates if "auto recovery" for the Outdoor Unit settings had to be invoked due to an unsuitable choice of frequency or power settings for the RF link.
1.3.6.1.4.1.1316.1.1.1.1.2.15	Deprecated1	INTEGER	write-only	Deprecated
1.3.6.1.4.1.1316.1.1.1.1.3	mdrmteG826			
1.3.6.1.4.1.1316.1.1.1.1.3.1	mdrmteStatus	INTEGER	read-only	Indicates if 'G.826-like' errored, severely errored and unavailable conditions have been monitored on the RF Link.
1.3.6.1.4.1.1316.1.1.1.1.3.2	mdrmteTotalSeconds	Counter	read-only	Indicates the total number of seconds, both available and unavailable.
1.3.6.1.4.1.1316.1.1.1.1.3.3	mdrmteAvailableSeconds	Counter	read-only	A period of unavailable time begins at the onset of ten consecutive SES events. These ten seconds are considered to be part of unavailable time. A new period of available time begins at the onset of ten consecutive non-SES events. These ten seconds are considered to be part of available time.
1.3.6.1.4.1.1316.1.1.1.1.3.4	mdrmteUnavailableSeconds	Counter	read-only	A period of unavailable time begins at the onset of ten consecutive SES events. These ten seconds are considered to be part of unavailable time. A new period of available time begins at the onset of ten consecutive non-SES events. These ten seconds are considered to be part of available time.
1.3.6.1.4.1.1316.1.1.1.1.3.5	mdrmteErroredSeconds	Counter	read-only	A one second period with one or more errored packets (uncorrectable packets) or at least one defect.
1.3.6.1.4.1.1316.1.1.1.1.3.6	mdrmteSeverelyErroredSeconds	Counter	read-only	A one-second period which contains > 30% errored blocks or at least one defect. SES is a subset of ES.
1.3.6.1.4.1.1316.1.1.1.1.3.7	mdrmteErroredBlocks	Counter	read-only	A packet that has been identified as containing uncorrectable bits by the FEC circuitry.
1.3.6.1.4.1.1316.1.1.1.1.3.8	mdrmteBackgroundBlockErrors	Counter	read-only	An errored block not occurring as part of a SES.

Object ID	Group	Object Type	Access	Description
1.3.6.1.4.1.1316.1.1.1.1.3.9	mdrmteErroredSecondsRatio	DisplayString	read-only	The ratio of ES to total seconds in available time during a fixed measurement interval.
1.3.6.1.4.1.1316.1.1.1.1.3.10	mdrmteSeverelyErroredSecondsRatio	DisplayString	read-only	The ratio of SES to total seconds in available time during a fixed measurement interval.
1.3.6.1.4.1.1316.1.1.1.1.3.11	mdrmteBackgroundBlockErrorRatio	DisplayString	read-only	The ratio of Background Block Errors (BBE) to total blocks in the available time during a fixed measurement interval. The count of total blocks excludes all blocks during SESs.
1.3.6.1.4.1.1316.1.1.1.1.3.12	Deprecated2	INTEGER	write-only	Deprecated
1.3.6.1.4.1.1316.1.1.1.1.3.13	mdrmteCorrectedSymbols	INTEGER	read-only	This parameter lists the number of corrected symbols i.e. those corrected by the FEC.
1.3.6.1.4.1.1316.1.1.1.1.4	Counters†			
1.3.6.1.4.1.1316.1.1.1.1.4.1	mdrmteLostEthRxPkts †	COUNTER	read-only	Indicates the total number of times an ethernet packet could not be buffered
1.3.6.1.4.1.1316.1.1.1.1.4.2	MdrmtelostLinkRxPkts †	COUNTER	read-only	Indicates the total number of times a link packet could not be buffered
1.3.6.1.4.1.1316.1.1.1.1.4.3	MdrmtelostWaySideTxPkts †	COUNTER	read-only	Indicates the total number of times a wayside packet could not be buffered
1.3.6.1.4.1.1316.1.1.1.1.4.4	mdrmteEtherRetries †	COUNTER	read-only	Indicates the total number of (collisions) packets that were retransmitted on Ethernet
1.3.6.1.4.1.1316.1.1.1.1.4.5	mdrmteScc1FullCnt†	COUNTER	read-only	Indicates the total number of times SCC1 was full to capacity
1.3.6.1.4.1.1316.1.1.1.1.4.6	mdrmteScc2FullCnt†	COUNTER	read-only	Indicates the total number of times SCC2 was full to capacity
1.3.6.1.4.1.1316.1.1.1.1.4.7	mdrmteScc1UnderrunCnt†	COUNTER	read-only	Indicates the total number of times SCC1 ran out of BDs
1.3.6.1.4.1.1316.1.1.1.1.4.8	mdrmteScc2UnderrunCnt†	COUNTER	read-only	Indicates the total number of times SCC2 ran out of BDs
1.3.6.1.4.1.1316.1.1.1.1.4.9	mdrmteScc2RxBdAbortCnt†	COUNTER	read-only	Indicates the total number of times SCC2 received an aborted frame
1.3.6.1.4.1.1316.1.1.1.1.4.10	mdrmteScc2RxBdNonOctCnt†	COUNTER	read-only	Indicates the total number of times SCC2 received a Non octet aligned frame
1.3.6.1.4.1.1316.1.1.1.1.4.11	mdrmteScc2RxBdCrcCnt†	COUNTER	read-only	Indicates the total number of times SCC2 received
1.3.6.1.4.1.1316.1.1.1.1.5	mdrmteResetAllPerfData	INTEGER	write-only	Reset all parameters associated with Packet Error and G.826 measurements for the RF Link.
1.3.6.1.4.1.1316.1.1.1.2	mdrmteConfiguration			
1.3.6.1.4.1.1316.1.1.1.2.1	MdrmtelayloadConf			
1.3.6.1.4.1.1316.1.1.1.2.1.1	MdrmtedataRate	INTEGER	read-write	Configure the tributary data interface rate - either E1 or T1.
1.3.6.1.4.1.1316.1.1.1.2.1.2	mdrmteLineCodeType	INTEGER	read-write	Defines the line code types for the tributaries, either HDB3 or AMI for E1 tributaries or B8ZS or AMI for T1 tributaries.
1.3.6.1.4.1.1316.1.1.1.2.1.3	mdrmtePcTable	SEQUENCE		
1.3.6.1.4.1.1316.1.1.1.2.1.3.1	mdrmtePcEntry	SYNTAX		
1.3.6.1.4.1.1316.1.1.1.2.1.3.1.1	mdrmtePcIndex	INTEGER		

Object ID	Group	Object Type	Access	Description
1.3.6.1.4.1.1316.1.1.1.2.1.3.1.2	mdrmtePcLabel	DisplayString	read-write	E1/T1 Payload configuration tributary label.
1.3.6.1.4.1.1316.1.1.1.2.1.3.1.3	mdrmtePcActive	INTEGER	read-write	Defines whether tributaries are active or inactive.
1.3.6.1.4.1.1316.1.1.1.2.2	mdrmteRFLinkConf			
1.3.6.1.4.1.1316.1.1.1.2.2.1	mdrmteTxPower	INTEGER	read-write	Allows setup of the output power available at the diplexer port of the Outdoor Unit.
1.3.6.1.4.1.1316.1.1.1.2.2.2	mdrmteBandPlan	INTEGER	read-write	The MDR5800 Outdoor Units operate in the 5.725 GHz to 5.850 GHz ISM frequency band. The MDR5800 has predefined frequency channel plans (termed A, B, C and D). Refer to the User's manual for details on defined frequencies.
1.3.6.1.4.1.1316.1.1.1.2.2.3	mdrmteTxFrequencyPlanD	INTEGER	read-write	Frequency plan D allows independent control of transmit and receive frequencies. This enables a very flexible frequency plan and can be used to overcome interference in the 5.8 GHz ISM band. The frequencies that can be used in the lower or upper sub-bands can be selected in 1 MHz increments. Performance degradation can be expected when operating using channel plan D mode and the chosen frequencies are close to the sub-band edges i.e. a choice of one of the high frequencies in the lower sub-band and one of the lower frequencies in the upper sub-band. The allocation of Channel plan D frequencies is Lower Sub-band - 5735-5771 MHz, Upper Sub-band - 5804-5840 MHz. The user must take note of whether the radio is a high or low band unit before choosing a set of transmit and receive frequencies. Note also that THE TX AND RX FREQUENCIES MUST BE SELECTED BEFORE BAND PLAN D OPTION IS SELECTED VIA THE MIB.
1.3.6.1.4.1.1316.1.1.1.2.2.4	mdrmteRxFrequencyPlanD	INTEGER	read-write	Refer to the mdrmtTxFrequencyPlanD description.
1.3.6.1.4.1.1316.1.1.1.2.2.5	mdrmteTransmitBand	INTEGER	read-only	This value is read from the Outdoor Unit via the Indoor Unit and defines whether it transmits in the Lower Sub-band - 5735-5771 MHz or Upper Sub-band - 5804-5840 MHz.
1.3.6.1.4.1.1316.1.1.1.2.2.6	MdrmtReserved2	INTEGER		
1.3.6.1.4.1.1316.1.1.1.2.2.7	mdrmteRegulations	INTEGER		This parameter is read from the Outdoor Unit via the Indoor Unit and defines regulatory compliance of the Outdoor Unit.
1.3.6.1.4.1.1316.1.1.1.2.2.8	mdrmteAutoRecovery	INTEGER	read-only	This feature is used if the user is installing a link from one side and there is no assistance on the opposite side of the link. It mitigates against the link failing and not being able to be re-established. If "auto recovery" is enabled, the required operational RF parameters are programmed into the Outdoor Units by the local and remote Indoor Units. If communication between the two

Object ID	Group	Object Type	Access	Description
				Indoor Units has not reactivated within 5 seconds, the previous (working) 'default' RF parameters are programmed into the respective Outdoor Units.
1.3.6.1.4.1.1316.1.1.1.2.2.9	mdrmteOURateOverride	INTEGER	read-write	Deprecated
1.3.6.1.4.1.1316.1.1.1.2.2.10	mdrmteOUDataRate	INTEGER	read-write	A settable rate that allows a reduced transfer data rate over the RF Link.
1.3.6.1.4.1.1316.1.1.1.2.2.11	mdrmteTxFrequencyCurrent	INTEGER	read-only	This value [MHz] is read back from the Outdoor Unit and defines the transmit frequency of the Outdoor Unit.
1.3.6.1.4.1.1316.1.1.1.2.2.12	mdrmteRxFrequencyCurrent	INTEGER	read-only	This value [MHz] is read back from the Outdoor Unit and defines the receive frequency of the Outdoor Unit.
1.3.6.1.4.1.1316.1.1.1.2.2.13	mdrmteNonAutoBandPlan	INTEGER	read-write	Same as mdrMTEBandPlan setting in this MIB group except "auto recovery" is not enabled - this allows control of the Outdoor Unit frequencies without the "auto recovery" feature attempting to intervene and re-establish setup of an operational RF Link.
1.3.6.1.4.1.1316.1.1.1.2.2.14	mdrmteNonAutoTxFreqPlanD	INTEGER	read-write	Same as mdrTxFrequencyPlanD setting in this MIB group except "auto recovery" is not enabled - this allows control of the Outdoor Unit Plan D frequencies without the "auto recovery" feature attempting to intervene and re-establish setup of an operational RF Link.
1.3.6.1.4.1.1316.1.1.1.2.2.15	mdrmteNonAutoRxFreqPlanD	INTEGER	read-write	Same as mdrTxFrequencyPlanD setting in this MIB group except "auto recovery" is not enabled - this allows control of the Outdoor Unit Plan D frequencies without the "auto recovery" feature attempting to intervene and re-establish setup of an operational RF Link.
1.3.6.1.4.1.1316.1.1.1.2.2.16	mdrmteNonAutoTxPower	INTEGER	read-write	Same as mdrTxPower setting in this MIB group except "auto recovery" is not enabled - this allows control of the Outdoor Unit power level setting without the "auto recovery" feature attempting to intervene and re-establish setup of an operational RF Link.
1.3.6.1.4.1.1316.1.1.1.2.3	mdrmteServiceChannel			
1.3.6.1.4.1.1316.1.1.1.2.3.1	mdrmteScDataRate ³	INTEGER	read-write	Bit rate used across the wayside service channel link.
1.3.6.1.4.1.1316.1.1.1.2.3.2	mdrmteScDataBits ⁴	INTEGER	read-write	The data width - can be 7 or 8 bits.
1.3.6.1.4.1.1316.1.1.1.2.3.3	MdrmtScParity	INTEGER	read-write	Serial channel - set to none, odd or even.
1.3.6.1.4.1.1316.1.1.1.2.3.4	MdrmtScStopBits	INTEGER	read-write	The number of stop bits can be set to 1 or 2.
1.3.6.1.4.1.1316.1.1.1.2.3.5	mdrmteScFlowControl	INTEGER	read-write	Either hardware or no flow control is used.

³ Fixed at 115.2kbps in Version 1.00 and 2.00, 2.01, 2.02 IU firmware releases.

⁴ Serial setting – 8 bits, no parity, 1 stop bit

Object ID	Group	Object Type	Access	Description
1.3.6.1.4.1.1316.1.1.1.2.3.6	mdrmteScStatusDump	INTEGER	read-write	Allows the wayside service (serial) channel to be used as a diagnostics port [deprecated].
1.3.6.1.4.1.1316.1.1.1.2.4	MdrmteGeneral			
1.3.6.1.4.1.1316.1.1.1.2.4.1	MdrmteStationName	DisplayString	read-write	The station name is stored in the Indoor Unit in non-volatile memory - limited to 14 characters in length.
1.3.6.1.4.1.1316.1.1.1.2.4.2	mdrmteIUSerialNumber	DisplayString	read-only	An electronic serial number is read from the Indoor Unit - this number is unique for each IU and is derived from an IC that is used within the product.
1.3.6.1.4.1.1316.1.1.1.2.4.3	mdrmteIUFirmwareVersion	DisplayString	read-only	The Indoor Unit firmware version is the version of application firmware that loaded into the product's application Flash.
1.3.6.1.4.1.1316.1.1.1.2.4.4	mdrmteIUBootkernelVersion	DisplayString	read-only	The Indoor Unit bootkernel version is the version of boot firmware that loaded into the product's Boot Flash.
1.3.6.1.4.1.1316.1.1.1.2.4.5	mdrmteOUsSerialNumber	INTEGER	read-only	The Outdoor Serial Number is programmed into the OU at time of manufacture and is read via the Indoor Unit.
1.3.6.1.4.1.1316.1.1.1.2.4.6	MdrmteOUPICFirmwareVersion	DisplayString	read-only	The Outdoor Unit PIC firmware number is programmed into the OU at time of manufacture and is read via the Indoor Unit.
1.3.6.1.4.1.1316.1.1.1.2.4.7	mdrmteOUPayloadSupport	INTEGER		Deprecated.
1.3.6.1.4.1.1316.1.1.1.2.4.8	mdrmteDate	DisplayString	read-write	This is a date record that is recovered from the Indoor Unit's Real Time Clock.
1.3.6.1.4.1.1316.1.1.1.2.4.9	mdrmteTime	DisplayString	read-write	This is a time record that is recovered from the Indoor Unit's Real Time Clock.
1.3.6.1.4.1.1316.1.1.1.2.4.10	mdrmteNOVRAMInit	INTEGER	read-write	If activated, the Nonvolatile memory is initialised to a set of default parameters.
1.3.6.1.4.1.1316.1.1.1.2.4.11	mdrmteFECBypass	INTEGER	read-write	This is primarily a laboratory test entry used to control whether the FEC circuitry within the Indoor Unit is activated. By default the FEC is not bypassed i.e. FEC is active.
1.3.6.1.4.1.1316.1.1.1.2.4.12	mdrmteFECCorrectableSymbols	INTEGER	read-write	This is primarily a laboratory test entry used to control the FEC correction power - 20 parity symbols are appended to the transmit packet - 10 is the maximum number of symbols the FEC circuitry can correct. At a maximum, 20 symbols in error can be detected but only 10 can be corrected - the higher the correction power selected, the greater the improvement in system gain.
1.3.6.1.4.1.1316.1.1.1.2.4.13	mdrmteTribCode	DisplayString	read-write	This is a text entry code (16 characters) used to allow activation of tributaries on the Indoor Units. It is unique to the Indoor Unit based on a hardware-dependent serial number in the IU.
1.3.6.1.4.1.1316.1.1.1.2.4.14	mdrmteIndoorUnitBarcodeNumber†	DisplayString	read-write	This is a text entry code used to allow storage of the Indoor Unit's bar code serial number (as seen on the outside of the on the outside of product's housing).

Object ID	Group	Object Type	Access	Description
1.3.6.1.4.1.1316.1.1.1.2.4.15	mdrmteIndoorUnitPCBrevision†	DisplayString	read-write	"This is a numeric entry code used to reflect the PCB revision number and modification status."
1.3.6.1.4.1.1316.1.1.1.2.5	mdrmteFirmware			
1.3.6.1.4.1.1316.1.1.1.2.5.1	mdrmteFTPServerStatus†	INTEGER	read-write	This allows activation/deactivation of the FTP server that runs in the Indoor Unit and is used to upload new revisions of firmware via a routed IP network.
1.3.6.1.4.1.1316.1.1.1.2.5.2	mdrmteFlashNewFirmware†	INTEGER	read-write	This entry determines the time when the new version of firmware will be activated.
1.3.6.1.4.1.1316.1.1.1.3	mdrmteFault			
1.3.6.1.4.1.1316.1.1.1.3.1	mdrmteInfo			
1.3.6.1.4.1.1316.1.1.1.3.1.1	mdrmteLEDTable	SEQUENCE		A group of LEDs on the front panel of the Indoor Unit.
1.3.6.1.4.1.1316.1.1.1.3.1.1.1	mdrmteLEDEntry	SYNTAX		A LED entry containing objects describing a particular LED.
1.3.6.1.4.1.1316.1.1.1.3.1.1.1.1	mdrmteLEDIndex	INTEGER		A unique value for each LED in the Indoor Unit. Its value ranges from 1 to the number of LEDs on the front panel of the Indoor Unit.
1.3.6.1.4.1.1316.1.1.1.3.1.1.1.2	mdrmteLEDLabel	DisplayString	read-only	SYSTEM Green OK, Orange (OU/IU Comms Error), Red (OU/IU Comms Down) PAYLOAD Green OK, Orange (AIS Detected), Red (LOS Detected)RF LINK Green OK, Orange (FEC Correcting Errors), Red (FEC unable to correct errors)In ALL cases flashing red and orange LEDs imply historic alarm conditions (The alarm can be cleared using the front panel button 'position 1': see next paragraph).
1.3.6.1.4.1.1316.1.1.1.3.1.1.1.3	mdrmteLEDState	INTEGER	read-only	The current state of the LED - for a detailed description of functionality, see the mdrmtLEDLabel entry.
1.3.6.1.4.1.1316.1.1.1.3.1.1.1.4	mdrmteLEDColour	INTEGER	read-only	The current colour of the LED - for a detailed description of functionality, see the mdrmtLEDLabel entry.
1.3.6.1.4.1.1316.1.1.1.3.1.2	mdrmteOutdoorUnitComms	INTEGER	read-only	Describes the state of communication with the Outdoor unit in terms of whether it is up or down completely. Alternatively, if there were errors, these are identified as comms errors (based on a CRC check) or content errors (i.e. undeclared, unused messages).
1.3.6.1.4.1.1316.1.1.1.3.1.3	mdrmteOutdoorUnitResetType	INTEGER	read-only	This message is read from the Outdoor Unit and identifies the last reason for a reset within the OU.
1.3.6.1.4.1.1316.1.1.1.3.1.4	mdrmteOutdoorUnitLockDetect	INTEGER	read-only	The transmit RF synthesizer, receive RF synthesizer and IF phased locked loop lock detect signals are monitored and reported via this MIB element.
1.3.6.1.4.1.1316.1.1.1.3.2	mdrmteSelfTest			
1.3.6.1.4.1.1316.1.1.1.3.2.1	mdrmteFlash	INTEGER	read-only	Identifies pass/fail status of the Indoor Unit's application flash.
1.3.6.1.4.1.1316.1.1.1.3.2.2	mdrmteDRAM	INTEGER	read-only	Identifies pass/fail status of the Indoor Unit's Dynamic RAM.

Object ID	Group	Object Type	Access	Description
1.3.6.1.4.1.1316.1.1.1.3.2.3	mdrmteSRAM	INTEGER	read-only	Identifies pass/fail status of the Indoor Unit's Static RAM.
1.3.6.1.4.1.1316.1.1.1.3.2.4	mdrmteLineInterface	INTEGER	read-only	Identifies pass/fail status of the Indoor Unit's Line Interface IC.
1.3.6.1.4.1.1316.1.1.1.3.2.5	mdrmteFPGA	INTEGER	read-only	Identifies pass/fail status of the Indoor Unit's FPGA interface registers to the microprocessor.
1.3.6.1.4.1.1316.1.1.1.3.2.6	mdrmteFEC	INTEGER	read-only	Identifies pass/fail status of the Indoor Unit's FEC IC electrical interface.
1.3.6.1.4.1.1316.1.1.1.3.2.7	mdrmteRealTimeClock	INTEGER	read-only	Identifies pass/fail status of the Indoor Unit's Real Time Clock.
1.3.6.1.4.1.1316.1.1.1.3.2.8	mdrmteIndoorUnitResetType	INTEGER	read-only	This message is read from the Indoor Unit and identifies the last reason for a reset within the IU.
1.3.6.1.4.1.1316.1.1.1.3.2.9	mdrmteLoopbackMode	INTEGER	read-write	Entry defines the loopback mode of a radio station in terms of loopback at either the payload line interface level, baseband processor level in an OU or RF loopback in the OU.
1.3.6.1.4.1.1316.1.1.1.3.2.10	mdrmteLoopbackTimeOut	INTEGER	read-write	This is the number of seconds the loopback will run for until it times out.
1.3.6.1.4.1.1316.1.1.1.3.3	mdrmteTrapManagement			
1.3.6.1.4.1.1316.1.1.1.3.3.1	mdrmteTrapFilter	INTEGER	read-write	Alarms within the MDR product are classified as critical, major, minor or informational. The trap filter allows screening of alarms before they are dispatched as traps.
1.3.6.1.4.1.1316.1.1.1.3.3.2	mdrmteNumberTrapManagers	INTEGER	read-only	This entry shows the number of trap managers allowed.
1.3.6.1.4.1.1316.1.1.1.3.3.3	mdrmteTrapManagerTable	SEQUENCE		
1.3.6.1.4.1.1316.1.1.1.3.3.3.1	mdrmteTrapManagerEntry	SYNTAX		
1.3.6.1.4.1.1316.1.1.1.3.3.3.1.1	mdrmteTrapManagerIndex	INTEGER		
1.3.6.1.4.1.1316.1.1.1.3.3.3.1.2	mdrmteTrapManagerIP	IpAddress	read-write	This is the IP address of the management station that is set up to detect and act upon received traps.
1.3.6.1.4.1.1316.1.1.1.3.3.3.1.3	mdrmteTrapManagerComm	DisplayString	read-write	This is the "SNMP community name" used for dispatch of traps.
1.3.6.1.4.1.1316.1.1.1.3.3.3.1.4	mdrmteTrapManagerActive	INTEGER	read-write	Defines whether a particular Trap Manager is active or inactive.
1.3.6.1.4.1.1316.1.1.1.3.4	mdrmtePerfTrapThreshold			
1.3.6.1.4.1.1316.1.1.1.3.4.1	mdrmteMinorPERThreshold	DisplayString	read-write	Defines the threshold used as a checking criterion for the Minor PER (Packet Error Rate).
1.3.6.1.4.1.1316.1.1.1.3.4.2	mdrmteMajorPERThreshold	DisplayString	read-write	Defines the threshold used as a checking criterion for the Major PER (Packet Error Rate).
1.3.6.1.4.1.1316.1.1.1.3.4.3	mdrmteCriticalPERThreshold	DisplayString	read-write	Defines the threshold used as a checking criterion for the Critical PER (Packet Error Rate).
1.3.6.1.4.1.1316.1.1.1.3.4.4	mdrmteErrSecRatioThreshold	DisplayString	read-write	Defines the threshold used as a checking criterion for the Errored Second Ratio.
1.3.6.1.4.1.1316.1.1.1.3.4.5	mdrmteSevErrSecRatioThreshold	DisplayString	read-write	Defines the threshold used as a checking criterion for the Severely Errored Second Ratio.
1.3.6.1.4.1.1316.1.1.1.3.4.6	mdrmteBkgmndBlkErrRatioThreshold	DisplayString	read-write	Defines the threshold used as a checking criterion for the Background Block Error Ratio.
1.3.6.1.4.1.1316.1.1.1.3.5	mdrmteEventLogTable	SEQUENCE		

Object ID	Group	Object Type	Access	Description
1.3.6.1.4.1.1316.1.1.1.3.5.1	mdrmteEventLogEntry	SYNTAX		
1.3.6.1.4.1.1316.1.1.1.3.5.1.1	mdrmteEventIndex	INTEGER		
1.3.6.1.4.1.1316.1.1.1.3.5.1.2	mdrmteEventDate	DisplayString	read-only	Lists the date on which the event occurred.
1.3.6.1.4.1.1316.1.1.1.3.5.1.3	mdrmteEventTime	DisplayString	read-only	Lists the time when the event occurred.
1.3.6.1.4.1.1316.1.1.1.3.5.1.4	mdrmteEventType	INTEGER	read-only	Lists the type of event - informational, minor, major or critical.
1.3.6.1.4.1.1316.1.1.1.3.5.1.5	mdrmteEventDescription	DisplayString	read-only	Textual description of the logged event.
1.3.6.1.4.1.1316.1.1.1.3.6	mdrmteClearEventLog	INTEGER	write-only	This entry is used to clear the Event Log.
1.3.6.1.4.1.1316.1.1.1.3.7	mdrmteResetAllFaults	INTEGER	write-only	
1.3.6.1.4.1.1316.1.1.1.3.8	mdrmteEnableDebug	INTEGER	read-write	This entry is used to enable test and debugging features
1.3.6.1.4.1.1316.1.1.1.3.9	mdrmteErrorWindow	INTEGER	read-write	This entry is used to set the time period in minutes during which errors are counted, but not logged.
1.3.6.1.4.1.1316.1.1.1.4	mdrmteAccess			
1.3.6.1.4.1.1316.1.1.1.4.1	mdrmteEthernetIPAddress	IpAddress	read-write	The IP address associated with product's Ethernet port (NOTE : USE A POWER-ON RESET OR RESET BUTTON POSITION '3' TO ALLOW ACCEPTANCE OF THE NEW IP ADDRESS – I.E. IT IS UPDATED IN NON-VOLATILE MEMORY AND GETS ACCEPTED BY THE INDOOR UNIT'S IP STACK AS A VALID ADDRESS).
1.3.6.1.4.1.1316.1.1.1.4.2	mdrmteEthernetNetMask	IpAddress	read-write	The netmask associated with the Ethernet port.
1.3.6.1.4.1.1316.1.1.1.4.3	mdrmteMaxNumUsers	INTEGER	read-only	If the firmware is complied with the security feature switched on, users can log into an IU. This value is read back from the IU and indicates the maximum number of users that can connect to an Indoor Unit.
1.3.6.1.4.1.1316.1.1.1.4.4	mdrmteMaxNumActiveUsers	INTEGER	read-only	If the firmware is built with the security feature switched on, users can log into an IU. This entry defines the maximum number of active users that can be connected to an Indoor Unit using IP.
1.3.6.1.4.1.1316.1.1.1.4.5	mdrmteNumActiveUsers	Gauge	read-only	If the firmware is built with the security feature switched on, users can log into an IU. This entry defines the number of active users logged into an IU.
1.3.6.1.4.1.1316.1.1.1.4.6	mdrmteUserTable	SEQUENCE		
1.3.6.1.4.1.1316.1.1.1.4.6.1	mdrmteUserEntry	SYNTAX		

Object ID	Group	Object Type	Access	Description
1.3.6.1.4.1.1316.1.1.1.4.6.1.1	mdrmteUserIndex	INTEGER		
1.3.6.1.4.1.1316.1.1.1.4.6.1.2	mdrmteUserName ⁵	DisplayString	read-write	If the firmware is built with the security feature switched on, users can log into an IU. This entry allows the user to enter a password associated with their sign-on name.
1.3.6.1.4.1.1316.1.1.1.4.6.1.3	mdrmteUserPassword	DisplayString	write-only	If the firmware is built with the security feature switched on, users can log into an IU – this entry allows password entry.
1.3.6.1.4.1.1316.1.1.1.4.6.1.4	mdrmteUserAccessLevel	INTEGER	read-write	If the firmware is built with the security feature switched on, users can log into an IU. The access entries that are used are "read_only" and "administrator". An administrator can add and delete new users, assign passwords, initialise NOVRAM via SNMP, enter tributary codes, adjust FTP server status, initiate new flash updates after an FTP upload. Read_only prevents the ability of the user to adjust the SETable variables in the MIB.
1.3.6.1.4.1.1316.1.1.1.4.6.1.5	mdrmteUserActive	INTEGER	read-write	Indicates if a user is active or not based on password entry.
1.3.6.1.4.1.1316.1.1.1.4.6.1.6	mdrmteUserAdd	INTEGER	write-only	In security-enabled mode, allows an administrator to add users.
1.3.6.1.4.1.1316.1.1.1.4.6.1.7	mdrmteUserDelete	INTEGER	write-only	In security-enabled mode, allows an administrator to delete users.
1.3.6.1.4.1.1316.1.1.1.4.7	mdrmteRFLinkIPAddress	IpAddress	read-write	PPP IP address for the RF Link. The user need not adjust this parameter.
1.3.6.1.4.1.1316.1.1.1.4.8	mdrmteRFLinkNetMask	IpAddress	read-write	PPP IP netmask for the RF Link. The user need not adjust this parameter.
1.3.6.1.4.1.1316.1.1.1.4.9	mdrmteRemotelIPAddress	IpAddress	read-write	Default PPP IP address for the other end of the RF link.
1.3.6.1.4.1.1316.1.1.1.4.10	MdrmteElementManagerIPAddress	IpAddress	read-write	Default PPP IP address for the the element manager port - 10.13.1.1 for a 'local IU' and 10.12.1.1 for a 'remote IU'.
1.3.6.1.4.1.1316.1.1.1.4.11	MdrmteElementManagerNetMask	IpAddress	read-write	IP netmask for the Element Manager PPP port.
1.3.6.1.4.1.1316.1.1.1.4.12	MdmrtelPNegotiable	INTEGER	read-write	Determines if the local PPP IP address is negotiable or not - does not need to be adjusted by the user.
1.3.6.1.4.1.1316.1.1.1.4.13	MdrmtePPPIsDefaultRoute	INTEGER	read-write	Determines if PPP interface is the default route - does not need to be adjusted by the user.
1.3.6.1.4.1.1316.1.1.1.4.14	MdrmteStaticRouteTable	SEQUENCE		
1.3.6.1.4.1.1316.1.1.1.4.14.1	MdrmteStaticRouteEntry	SYNTAX		
1.3.6.1.4.1.1316.1.1.1.4.14.1.1	MdrmteStaticRouteIndex	INTEGER		
1.3.6.1.4.1.1316.1.1.1.4.14.1.2	MdrmteStaticRouteIPAddressDestination	IpAddress	read-write	Ultimate destination.
1.3.6.1.4.1.1316.1.1.1.4.14.1.3	MdrmteStaticRouteIPAddressMask	IpAddress	read-write	net mask, 255.255.255.255 if destination is host address.
1.3.6.1.4.1.1316.1.1.1.4.14.1.4	mdrmteStaticRouteIPAddressNextHop	IpAddress	read-write	Where to forward to.
1.3.6.1.4.1.1316.1.1.1.4.14.1.5	mdrmteStaticRouteInterfaceForNextHop	INTEGER	read-write	Interface (net) for nexthop.

⁵ The default build for firmware DOES NOT include a SECURE LOGIN option.

Object ID	Group	Object Type	Access	Description
1.3.6.1.4.1.1316.1.1.1.4.15	mdrmteBridgeEnable†	INTEGER	read-write	Determines if the system is to act as a transparent bridge for all Ethernet packets received.
1.3.6.1.4.1.1316.1.1.1.4.16	mdrmteEthernetFullDuplex†	INTEGER	read-write	Determines if the Ethernet interface is full- or half-duplex.
1.3.6.1.4.1.1316.1.1.1.5	mdrmteRelayOutputs			
1.3.6.1.4.1.1316.1.1.1.5.1	mdrmteRelay1			
1.3.6.1.4.1.1316.1.1.1.5.1.1	mdrmteRelay1Label	DisplayString	read-write	A short, descriptive name indicating the primary function of the relay, most probably in terms of the equipment connected to it.
1.3.6.1.4.1.1316.1.1.1.5.1.2	mdrmteRelay1OpenStateLabel	DisplayString	read-write	A short, descriptive name indicating the primary function of the relay in the open state, most probably in terms of the equipment connected to it.
1.3.6.1.4.1.1316.1.1.1.5.1.3	mdrmteRelay1ClosedStateLabel	DisplayString	read-write	A short, descriptive name indicating the primary function of the relay in the closed state, most probably in terms of the equipment connected to it.
1.3.6.1.4.1.1316.1.1.1.5.1.4	mdrmteRelay1Reserved	INTEGER		
1.3.6.1.4.1.1316.1.1.1.5.1.5	mdrmteRelay1CurrentState	INTEGER	read-write	The current state of the relay. Used to activate/deactivate a relay.
1.3.6.1.4.1.1316.1.1.1.5.1.6	mdrmteRelay1ScriptTable	SEQUENCE		
1.3.6.1.4.1.1316.1.1.1.5.1.6.1	mdrmteRelay1ScriptEntry	SYNTAX		
1.3.6.1.4.1.1316.1.1.1.5.1.6.1.1	mdrmteRelay1ScriptIndex† ⁶	INTEGER		
1.3.6.1.4.1.1316.1.1.1.5.1.6.1.2	mdrmteRelay1ScriptID	INTEGER	read-write	Defines which of the listed alarms can cause a relay to activate.
1.3.6.1.4.1.1316.1.1.1.5.1.6.1.3	mdrmteRelay1ScriptActiveLocal	INTEGER	read-write	Defines if the script is active or not for local relay activation.
1.3.6.1.4.1.1316.1.1.1.5.1.6.1.4	mdrmteRelay1ScriptActiveRemote	INTEGER	read-write	Defines if the script is active or not for remote relay activation.
1.3.6.1.4.1.1316.1.1.1.5.2	mdrmteRelay2			
1.3.6.1.4.1.1316.1.1.1.5.2.1	mdrmteRelay2Label	DisplayString	read-write	A short, descriptive name indicating the primary function of the relay, most probably in terms of the equipment connected to it.
1.3.6.1.4.1.1316.1.1.1.5.2.2	mdrmteRelay2OpenStateLabel	DisplayString	read-write	A short, descriptive name indicating the primary function of the relay in the open state, most probably in terms of the equipment connected to it.
1.3.6.1.4.1.1316.1.1.1.5.2.3	mdrmteRelay2ClosedStateLabel	DisplayString	read-write	A short, descriptive name indicating the primary function of the relay in the closed state, most probably in terms of the equipment connected to it.
1.3.6.1.4.1.1316.1.1.1.5.2.4	mdrmteRelay2Reserved	INTEGER		
1.3.6.1.4.1.1316.1.1.1.5.2.5	mdrmteRelay2CurrentState	INTEGER	read-write	The current state of the relay. Used to activate/deactivate a relay.
1.3.6.1.4.1.1316.1.1.1.5.2.6	mdrmteRelay2ScriptTable	SEQUENCE		
1.3.6.1.4.1.1316.1.1.1.5.2.6.1	mdrmteRelay2ScriptEntry	SYNTAX		
1.3.6.1.4.1.1316.1.1.1.5.2.6.1.1	mdrmteRelay2ScriptIndex	INTEGER		
1.3.6.1.4.1.1316.1.1.1.5.2.6.1.2	mdrmteRelay2ScriptID	INTEGER	read-write	Defines which of the listed alarms can cause a relay to activate.

⁶ Relay scripting is not activated in Versions 1.00 & 2.00, 01, 02 of the IU firmware release.

Object ID	Group	Object Type	Access	Description
1.3.6.1.4.1.1316.1.1.1.5.2.6.1.3	mdrmteRelay2ScriptActiveLocal	INTEGER	read-write	Defines if the script is active or not for local relay activation.
1.3.6.1.4.1.1316.1.1.1.5.2.6.1.4	mdrmteRelay2ScriptActiveRemote	INTEGER	read-write	Defines if the script is active or not for remote relay activation.
1.3.6.1.4.1.1316.1.1.1.6	mdrmteOptoInputs			
1.3.6.1.4.1.1316.1.1.1.6.1	mdrmteOptoInput1			
1.3.6.1.4.1.1316.1.1.1.6.1.1	mdrmteOptoInput1Label	DisplayString	read-write	A short, descriptive name indicating the primary function of the contact-closure input in the closed state, most probably in terms of the equipment connected to it.
1.3.6.1.4.1.1316.1.1.1.6.1.2	mdrmteOptoInput1State	INTEGER	read-only	Indicates if the opto input contact-closure input is active (on) or not (off).
1.3.6.1.4.1.1316.1.1.1.6.2	mdrmteOptoInput2			
1.3.6.1.4.1.1316.1.1.1.6.2.1	mdrmteOptoInput2Label	DisplayString	read-write	A short, descriptive name indicating the primary function of the contact-closure input in the closed state, most probably in terms of the equipment connected to it.
1.3.6.1.4.1.1316.1.1.1.6.2.2	mdrmteOptoInput2State	INTEGER	read-only	Indicates if the opto input contact-closure input is active (on) or not (off).

10.3 The MIB elements – TRAP DESCRIPTIONS

1	MdrmtTrapUndefined: Informational	
2	MdrmtTrapPayloadLOS: Critical	Indicates a Loss of Signal identified on the INPUT TO a tributary.
3	MdrmtTrapPayloadAIS: Critical	Indicates an Alarm Indication Signal ' all 1's ' identified/sensed on the INPUT TO a tributary.
4	MdrmtTrapLinkUnavailable: Critical	Indicates, based on G.826 criteria if the RF Link has become unavailable.
5	MdrmtTrapLinkFrameUnlock: Critical	Indicates a Frame Unlock condition identified in the Indoor Unit.
6	MdrmtTrapLinkOuSynthUnlock: Critical	Indicates if a synthesizer unlock condition was identified in the Outdoor Unit.
7	MdrmtTrapLinkMinorPERExceeded: Minor	Indicates the minor packet error rate threshold was exceeded.
8	MdrmtTrapLinkMajorPERExceeded: Major	Indicates the major packet error rate threshold was exceeded.
9	MdrmtTrapLinkCriticalPERExceeded: Critical	Indicates the critical packet error rate threshold was exceeded.
10	MdrmtTrapLinkESRExceeded: Minor	Indicates the Link Errored Second Ratio Threshold limit was exceeded.
11	MdrmtTrapLinkSESRExceeded: Critical	Indicates the Link Severely Errored Second Ratio threshold limit was exceeded.
12	MdrmtTrapLinkBBERExceeded: Minor	Indicates the Link Background Block Error Rate threshold limit was exceeded.
13	MdrmtTrapFTPUploadDone: Informational	Indicates FTP Upload done.
14	MdrmtTrapFlashEraseFail: Informational	Indicates failure to erase Application flash.
15	MdrmtTrapFirmwareUpgradePass: Informational	Indicates that firmware was uploaded successfully.
16	MdrmtTrapFirmwareUpgradeFail: Informational	Indicates that there was a firmware upload failure.
17	MdrmtTrapInterstationCommsTimeOut: Major	Indicates an interstation communications timeout.
18	MdrmtTrapInterstationCommsInvalidResponse: Minor	Indicates a communications error on the interstation overhead link.
19	MdrmtTrapOUCommsTimeOut: Major	Indicates an Outdoor Unit communications timeout.
20	MdrmtTrapOUCommsInvalidResponse: Minor	Indicates an Outdoor Unit communications error - an invalid response was received.
21	MdrmtTrapOUCommsTxFail	Indicates Outdoor Unit communications transmit failure.
22	MdrmtTrapSSPCRCErrors: Minor	Simple Serial Protocol CRC error identified.
23	MdrmtTrapSSPLengthError: Minor	Simple Serial Protocol Length error identified.
24	mdrmtTrapOptoInput1Off: Major	Contact closure input off state detected - Opto 1.
25	mdrmtTrapOptoInput1On: Major	Contact closure input off state detected - Opto 1.
26	mdrmtTrapOptoInput2Off: Major	Contact closure input off state detected - Opto 2.
27	mdrmtTrapOptoInput2On: Major	Contact closure input on state detected - Opto 2.
28	mdrmtTrapUserLoginFailed: Informational	With security MODE ON - indicates a user attempted to log on and the attempt failed.
29	mdrmtTrapUserLogoutFailed: Informational	With security MODE ON - indicates a user attempted to log out and the attempt failed.
30	MdrmtTrapUserAddFailed: Informational	With security MODE ON - indicates there was an attempt to add a user, but the attempt failed.
31	mdrmtTrapUserDeleteFailed: Informational	With security MODE ON - indicates there was an attempt to remove/delete a user, but the attempt failed.
32	MdrmtTrapUserLogIn: Informational	With security MODE ON - indicates a user logged in.
33	MdrmtTrapUserLogOut: Informational	With security MODE ON - indicates a user logged out.
34	MdrmtTrapUserAdd: Informational	With security MODE ON - indicates a user was added successfully.
35	MdrmtTrapUserDelete: Informational	With security MODE ON - indicates a user was deleted successfully.
36	MdrmtTrapOUSetBandPlan: Informational	Indicates the Outdoor Unit channel/band plan was changed.
37	mdrmtTrapOUSetTxChannel: Informational	Indicates the Outdoor Unit transmit frequency was changed.
38	mdrmtTrapOUSetRxChannel: Informational	Indicates the Outdoor Unit receive frequency was changed.

39	MdrmtTrapOUEepromWrite: Minor	Indicates there was an attempt to write to the Outdoor Unit EEPROM.
40	mdrmtTrapOUSetTxPower: Informational	Indicates there was an attempt to change the transmit power.
41	MdrmtTrapOUSetPNCode – NA	Deprecated.
42	MdrmtTrapOUSetAutoRecovery	Indicates there was an attempt to change the “auto recovery” setting.
43	MdrmtTrapOUProgramConfig	Deprecated.
44	mdrmtTrapOUChangeRFLoopback: Informational	Indicates a change the OU RF Loopback setting was implemented.
45	mdrmtTrapOUChangeBBPLoopback: Informational	Indicates a change the Baseband Processor Loopback setting was implemented.
46	MdrmtTrapOUWriteBBP: Minor	Indicates there was an attempt to write to the Baseband Processor.
47	MdrmtTrapSetDate: Informational	Indicates the Indoor Unit date was adjusted.
48	MdrmtTrapSetTime: Informational	Indicates the Indoor Unit time was adjusted.
49	MdrmtTrapSynchronizeSwRTC: Informational	Indicates the Indoor Unit's time was synchronized with its real-time clock.
50	MdrmtTrapSetRelayLabel	A relay label was changed.
51	MdrmtTrapSetRelayOpenStateLabel	A relay open-state label was changed.
52	mdrmtTrapSetRelayClosedStateLabel	A relay closed-state label was changed.
53	MdrmtTrapSetRelayDefaultState: NA	Deprecated.
54	mdrmtTrapSetRelayCurrentState: Informational	Relay's current state has changed.
55	mdrmtTrapRelayScriptEnable	Relay scripting is enabled.
56	mdrmtTrapRelayScriptDisable	Relay scripting is disabled.
57	MdrmtTrapGetEventLog: Informational	Indoor Unit's event log is being accessed.
58	MdrmtTrapClearEventLog: Informational	Indoor Unit's event log is being cleared.
59	MdrmtTrapSelfTestFailure: Major	Indoor Unit's self test failed.
60	MdrmtTrapProcessorReset: Critical	There was an Indoor Unit processor reset.
61	MdrmtTrapEtherRx	There was an Indoor Unit Receive Ethernet buffer error.
62	MdrmtTrapTest: Informational	Test trap.
63	MdrmtTrapGenericText	Test trap.
64	mdrmtTrapGenericText_Data	Test trap.
65	mdrmtTrapGenericText_DecData	Test trap.
66	mdrmtTrapSocket_Error	Test trap.

11 APPENDIX C: SETUP OF A PC (WIN 95, 98, NT) TO ALLOW PINGING OF A 'REMOTE'-CONFIGURED INDOOR UNIT

The following diagram shows the default (factory) network IP addresses assigned to the various network ports on the MDR System: ROUTING CONFIGURATION

11.1 IP CONFIGURATION OF THE MDR – ROUTING CONFIGURATION

MDR - ROUTING CONFIGURATION

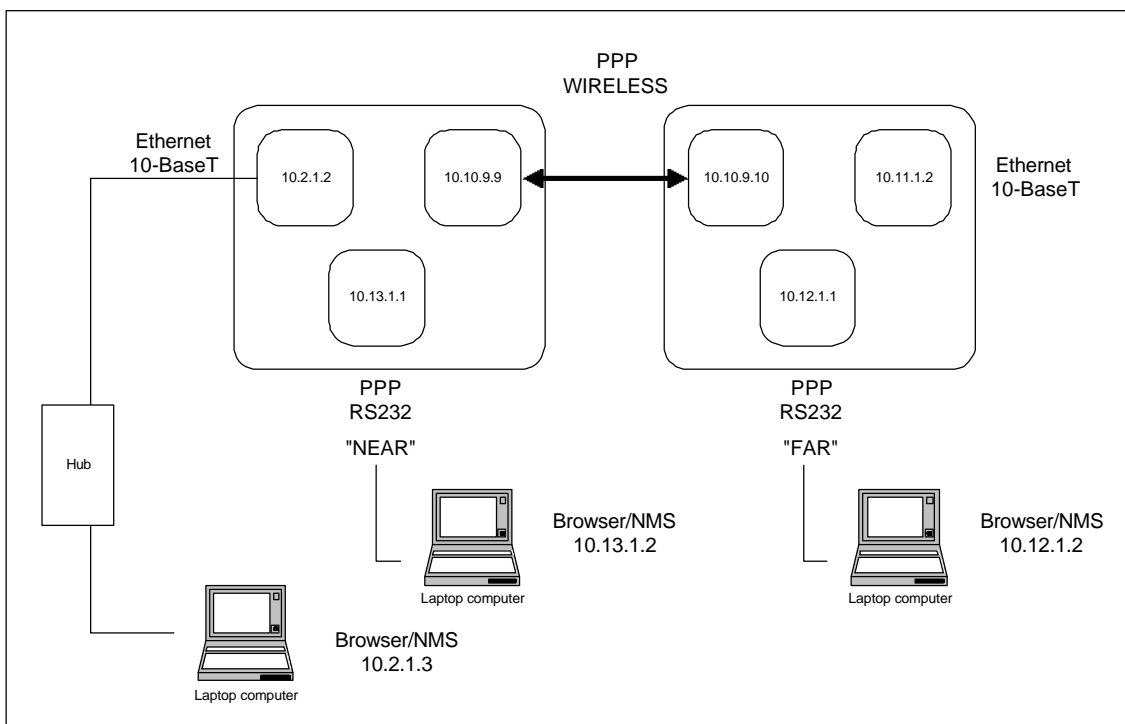

To allow pinging of an IU configured as a "remote unit" i.e. with an IP address of (10.11.1.2) when the PC has a 10.2.1.3 IP address, 10.2.1.2 default gateway and netmask 255.255.0.0, create batch files.

Batch file 1 - addroute.bat

```
route add 10.11.0.0 mask 255.255.0.0 10.2.1.3
```

Batch file 1 adds a route so that the IP stack on the PC "knows" where to send IP packets destined for the net 10.11.0.0

If you want to delete the route, use

Batch file 2 - delroute.bat

```
route delete 10.11.0.0
```

If you want a screen printout of the routes the PC is using, use the command line entry:

```
route print
```

NOTE



DO NOT ALLOW AN RF LINK TO ESTABLISH BEFORE DOING A PING on the remote IU (with 10.11.1.2 as an IP address) - if the RF link was established before, use the front panel button "position 3" to reset the IU before attempting to ping.

11.2 IP CONFIGURATION OF THE MDR – BRIDGING AND ROUTING CONFIGURATION

The following diagram shows the default (factory) network IP addresses assigned to the various network ports on the MDR System: BRIDGING AND ROUTING CONFIGURATION.

Note : For most networks, bridging is the preferred IP configuration.

MDR - BRIDGING OR ROUTING DEFAULT CONFIGURATION

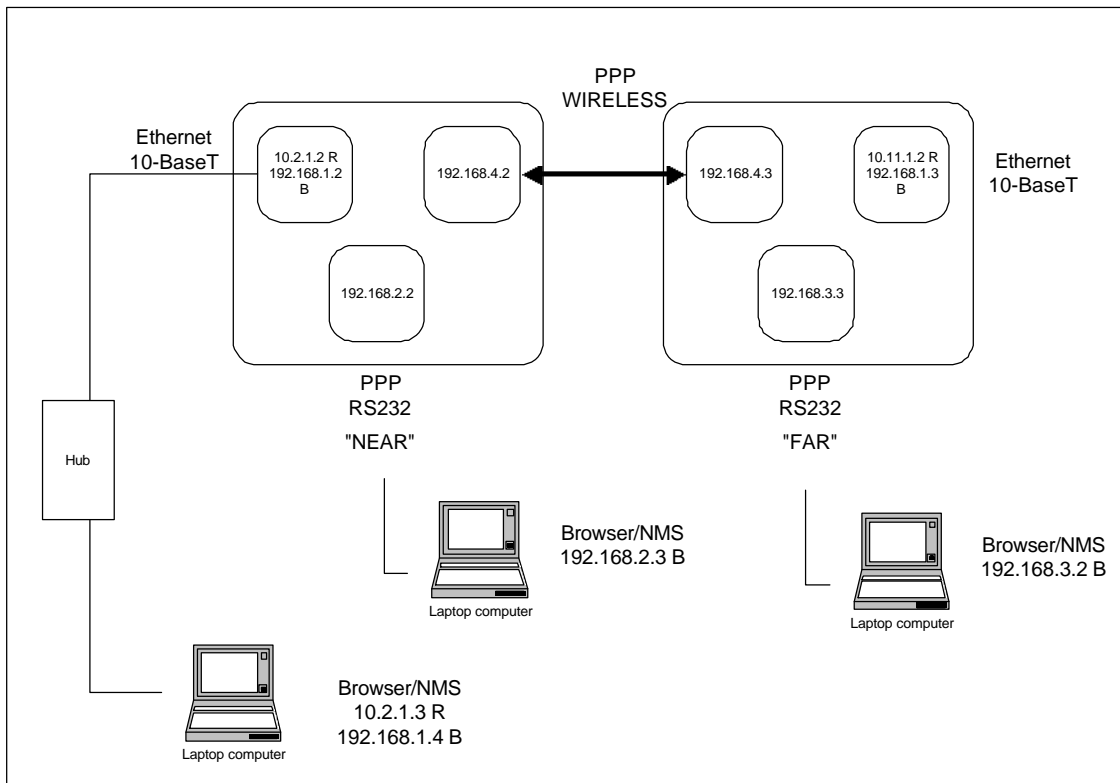

Note : The netmask for all the 192.168.x.x addresses is 255.255.255.0

The netmask for all the 10.x.x.x addresses is 255.255.0.0

R above refers to "IP routing"

B above refers to "Ethernet bridging"

12 APPENDIX D: MDR5800 HARDWARE VERSION 1, 2.X DIFFERENCES, COMPATIBILITY SUMMARY

Version 1 hardware (Indoor and Outdoor Units) is **incompatible** with Version 2.x hardware.

- The Indoor Unit /Outdoor Unit Twisted Pair Data Interconnection for Version 2 hardware uses 2 twisted pair cables to convey payload and Outdoor Unit control signals whereas Version 1 hardware uses 4 twisted pair cables.

Notes :

Version 2.x firmware (can be uploaded into the Indoor Unit using the NMS's Maintenance option) that can be used in Version 1.x hardware must be obtained from the product manufacturer. The file is **not** the same file that is used with Version 2.x hardware.

Updated RSSI and Power control functionality have been added to Version 2.x hardware and firmware.

Version 2.x firmware has

1. FTP upload functionality (needs to be activated via the MIB)
2. IP Bridging functionality (half and full duplex – selectable via the MIB). Appropriate IU hardware must be used.
3. Band Plan C
4. Refer to the MIB section of this manual and look for the † symbol to see what MIB-related functionality is in place/activated/planned for Version 2.x + firmware.
5. Functional RF Loopback built-in test feature.
6. Ethernet packet error monitoring and buffer monitoring added to MIB
7. E1 CRC4 payload monitoring added to MIB (only applicable for a single tributary)
8. Indoor Unit PCB hardware revision added to MIB
9. Periodic reporting of RF Link packet errors (adjustable in time, defaulted to 10 minutes) added to MIB.

Version 2.x NMS has

1. Ability to allow the user to connect to the Indoor Unit using PPP (via a serial cable interface to the IU's front panel Element Manager RS232 port) or via Ethernet (via the front panel RJ45 connector: 10BaseT).
2. Graphical Spectrum Analyzer display

By default, firmware provided for the Indoor Units does not provide a secure login feature (thereby limiting a user's ability to 'set' MIB variables). Suitably adapted firmware versions (dependent on hardware version) need to be requested from the product manufacturer to allow activation of this feature.

INDOOR UNIT FIRMWARE UPGRADE NOTICE

MDR Version 2 hardware Indoor Units are identified as having 200+ serial numbers, Outdoor Units have 250+ serial numbers.

If upgrading Indoor Units to use V2.02+ IU firmware, upgrade the IU firmware on **BOTH** sides of the RF Link.

Note that firmware upgrades of Version 1 Indoor Unit hardware do not require setting up of the PCB Issue in the MIB i.e. mdrmtIndoorUnitPCBreversion element. Upgrade to IU firmware Version 2+ of Version 1 hardware will **NOT** give improved RSSI functionality. This is only achieved with Version 2 hardware or modified version 1 hardware.

As a standard setting for mdrmtIndoorUnitPCBreversion, use MIB selection Issue_2. **HOWEVER**, if an appropriate Indoor PCB modification (made at the factory) has been made to allow Full Duplex Ethernet operation, the Issue_2_Mod_A selection option in the MIB **MUST** be used.

13 APPENDIX E: MDR5800 FIXED ANTENNAS

The table below identifies the distances where the 1mW/cm² exposure limits may be exceeded during continuous transmission using the proposed fixed antennas.

Manufacturer	Type	Model	Gain (dBi)	Numeric gain	Channel	Peak Power (mW)	Calculated Distance (m)	Minimum RF Exposure Separation Distance (m)
Gabriel	Dish	SSSP2 52B	29.0	794.3	3	239.9	1.2	2
Gabriel	Flat panel	DFPD1-52	23.9	245.5	3	239.9	0.7	2
MTI	Flat panel	MT-20004	28.0	631.0	3	239.9	1.1	2

WARNING: It is the responsibility of the professional installer to ensure that when using the outdoor antenna kits in the United States (or where FCC rules apply), only these antenna configurations shown in the table above are used. The use of any antenna other than those listed is expressly forbidden in accordance to FCC rules CFR47 part 15.204.

FCC Radiation Exposure Statement

This equipment complies with FCC radiation exposure limits set forth for an uncontrolled environment when installed as directed. This equipment should be installed and operated with fix-mounted antennas that are installed with a minimum of 2 meters of separation distance between the antenna and all persons body during normal operation and the antennas as shown above.

14 APPENDIX F: USEFUL WEB LINKS

The URL <http://www.plesseyinc.com/support.htm> provides a lot of detailed support information for the MDR product.

Please note that the MDR2400 referenced on the above site is the 1E1 variant.

The <http://www.plessmdr.co.za/> site is used to download the latest variants of IU firmware and NMS software.

15 APPENDIX F: MDR5800 SCALABLE 1-TO-4 E1 / 10 BASE-T ETHERNET FUNCTIONALITY

There is a total of 10 Mbps combined send-and-receive data throughput capability via the Ethernet interfaces on either side of an MDR5800 link.

As E1 tributaries are deactivated, more bandwidth becomes available for the 10BaseT Ethernet Interfaces.

Case 1 : 3 x E1's active, 2 Mbps 10BaseT Ethernet possible in both directions i.e. 4 Mbps aggregate.

Case 2 : 2 x E1's active, 4 Mbps 10BaseT Ethernet possible in both directions i.e. 8 Mbps aggregate.

Case 3 : 1 x E1 active, 10 Mbps aggregate shared in both directions.

e.g. with a maximum of 6 Mbps in any one direction (leaving 4 Mbps for return traffic when that occurs)

Case 4 : No E1's active, 10 Mbps aggregate shared in both directions.

e.g. with a maximum of 8 Mbps in any one direction (leaving 2 Mbps for return traffic when that occurs)