

# **GSM-EDGE REPEATERS**

**Product Description and  
User's Manual**



# GSM-EDGE 900, 1800 and 1900 Repeaters

## Product Description and User's Manual

This document is valid for Firmware version 1.03 and RMC version 2.12

This document is valid for the repeater models:

- CSR 922, CSR924, CSR 924H
- CSR 1822, CSR 1824
- CSR 1922, CSR 1924
- CSFT 922, CSFT 91822
- CSFT 1822, CSFT 18922
- CSFT 1922
- CSF 922

## Copyright © 2004 AVITEC AB

All rights reserved.

No part of this document may be copied, distributed, transmitted, transcribed, stored in a retrieval system, or translated into any human or computer language without the prior written permission of Avitec AB.

The manufacturer has made every effort to ensure that the instructions contained in this document are adequate and free of errors and omissions. The manufacturer will, if necessary, explain issues which may not be covered by this document. The manufacturer's liability for any errors in the document is limited to the correction of errors and the aforementioned advisory services.

This document has been prepared to be used by professional and properly trained personnel, and the customer assumes full responsibility when using them. The manufacturer welcomes customer comments as part of the process of continual development and improvement of the documentation in the best way possible from the user's viewpoint. Please submit your comments to the nearest Avitec AB sales representative.

## Table of Contents

<b>1</b>	<b>Repeater Technology .....</b>	<b>13</b>
1.1	Basic Features.....	13
1.2	Repeater Types .....	13
1.3	Repeater Applications .....	17
1.4	Software Overview .....	20
<b>2</b>	<b>Product Description .....</b>	<b>21</b>
2.1	Repeater Models.....	21
2.2	Characteristics .....	22
2.3	Casing.....	28
2.4	Connections .....	30
2.5	Power and Back-up Battery.....	34
2.6	Building Blocks .....	34
2.7	Internal Connections.....	40
2.8	Signal Paths .....	42
<b>3</b>	<b>Monitoring and Control .....</b>	<b>46</b>
3.1	Software Features .....	46
3.2	RF Parameters .....	50
3.3	Hardware Identification.....	54
3.4	Alarm System.....	55
3.5	Repeater Heartbeat .....	65
3.6	Traffic Measurement .....	66
3.7	Remote Communication.....	70
3.8	Upgrading Repeater Firmware .....	84
<b>4</b>	<b>Installation .....</b>	<b>85</b>
4.1	Prepare the Site.....	86
4.2	Install the Repeater .....	104
4.3	Start-up the Repeater .....	115
4.4	Configure the Repeater.....	120
4.5	Installation Checklists .....	136
<b>5</b>	<b>Maintenance .....</b>	<b>141</b>
5.1	General .....	141
5.2	Preventive Maintenance .....	141
<b>6</b>	<b>Specifications .....</b>	<b>142</b>
6.1	CSR 922 .....	142
6.2	CSR 924 .....	144

**PRODUCT DESCRIPTION AND USER'S MANUAL**

---

6.3	CSR 924 H.....	146
6.4	CSR1822 .....	148
6.5	CSR1824 .....	150
6.6	CSR1922 .....	152
6.7	CSR1924 .....	154
6.8	CSFT 922 .....	156
6.9	CSFT 1822 .....	160
6.10	CSFT 1922 .....	164
6.11	CSFT 91822 .....	168
6.12	CSFT 18922 .....	172
6.13	CSF 922.....	176

## Safety Instructions and Warnings

### Guarantees

All antennas must be installed with lightning protection. Damage to power modules, as a result of lightning are not covered by the warranty.

Switching on AC or DC power prior to the connection of antenna cables is regarded as faulty installation procedure and therefore not covered by the Avitec warranty.

#### **Caution**

This equipment has been tested and found to comply with the limits for a Class A digital device, pursuant to part 15 of the FCC Rules. These limits are designed to provide reasonable protection against harmful interference when the equipment is operated in a commercial environment. This equipment generates, uses, and can radiate radio frequency energy and, if not installed and used in accordance with the instruction manual, may cause harmful interference to radio communications. Operation of this equipment in a residential area is likely to cause harmful interference in which case the user will be required to correct the interference at his own expense.

### Safety to Personnel

Before installing or replacing any of the equipment, the entire manual should be read and understood. The user needs to supply the appropriate AC or DC power to the repeater. Incorrect power settings can damage the repeater and may cause injury to the user.

#### **Caution**

Please be aware that the equipment may, during certain conditions become very warm and can cause minor injuries if handled without any protection, such as gloves.

Throughout this manual, there are "Caution" warnings. "Caution" calls attention to a procedure or practice, which, if ignored, may result in injury or damage to the system, system component or even the user. Do not perform any procedure preceded by a "Caution" until the described conditions are fully understood and met.

#### **Caution**

This notice calls attention to a procedure or practice that, if ignored, may result in personal injury or in damage to the system or system component.  
Do not perform any procedure preceded by a "Caution" until described conditions are fully understood and met.

### Class IIIa Laser

Relevant for fibre fed repeaters only.

#### **Caution**

Un-terminated optical receptacles may emit laser radiation.  
Do not stare into beam or view with optical instruments.



Optical transmitters in the opto module can send out high energy invisible laser radiation. There is a risk for permanent damage to the eye.

## PRODUCT DESCRIPTION AND USER'S MANUAL

---

Always use protective cover on all cables and connectors which are not connected. Never look straight into a fibre cable or a connector. Consider that a fibre can carry transmission in both directions.

During handling of laser cables or connections ensure that the source is switched off. Regard all open connectors with respect and direct them in a safe direction and never towards a reflecting surface. Reflected laser radiation should be regarded as equally hazardous as direct radiation.

### Safety to Equipment

When installing, replacing or using this product, observe all safety precautions during handling and operation. Failure to comply with the following general safety precautions and with specific precautions described elsewhere in this manual violates the safety standards of the design, manufacture, and intended use of this product. Avitec AB assumes no liability for the customer's failure to comply with these precautions. This entire manual should be read and understood before operating or maintaining the repeater.

### Electrostatic Sensitivity

Observe electrostatic precautionary procedures.

**Caution**

ESD = Electrostatic Discharge Sensitive Device

Semiconductor transmitters and receivers provide highly reliable performance when operated in conformity with their intended design. However, a semiconductor may be damaged by an electrostatic discharge inadvertently imposed by careless handling.

Static electricity can be conducted to the semiconductor chip from the centre pin of the RF input connector, and through the AC connector pins. When unpacking and otherwise handling the repeater, follow ESD precautionary procedures including use of grounded wrist straps, grounded workbench surfaces, and grounded floor mats.

## References

[1] EN 301 502

Harmonized EN for Global System for Mobile communications (GSM); Base station and Repeater equipment covering essential requirements under article 3.2 of the R&TTE directive (GSM 13.21 version 8.1.2. Release 1999)

[2] ETS 300 342-3

Radio Equipment and Systems (RES); Electro-Magnetic Compatibility (EMC) for European Digital Cellular Telecommunications systems. Base Station Radio and ancillary equipment and Repeaters meeting phase 2 GSM requirements.

## Contact Information

Phone                   +46 8 475 47 00

Fax                      +46 8 475 47 99

Email                   [support@avitec.se](mailto:support@avitec.se)

Web                     <http://www.avitec.se>

Address                Avitec AB

                          Box 20116

                          S-161 02 Bromma

                          SWEDEN



## Definitions, Abbreviations and Acronyms

AEM	<p>Avitec® Element Manager</p> <p>A software tool for operation and monitoring a network consisting of Avitec products.</p>
ALC	Automatic Limit Control
Antenna	The part of a radio transmission system designed to radiate or receive electromagnetic waves
Antenna beamwidth	More properly referred to as the half-power beamwidth, this is the angle of an antenna pattern or beam over which the relative power is at or above 50% of the peak power
Antenna directivity	This is the relative gain of the main beam of an antenna pattern to a reference antenna, usually an isotropic or standard dipole
ARFCN	Absolute Radio Frequency Channel Number. A channel numbering scheme used to identify specific RF channels in a GSM radio system
Band	In wireless communication, band refers to a frequency or contiguous range of frequencies. Currently, wireless communication service providers use the 900 MHz, 1800 MHz and 1900 MHz bands for transmission
Base station	The central radio transmitter/receiver that maintains communications with a mobile radio equipment within a given range
BCCH	Broadcast Control Channel. A downlink point to multipoint logical channel in GSM used to send identification and organization information about common control channels and cell services
BSR	Band Selective Repeater
BTS	<p>Base Transceiver Station, one part of a base station.</p> <p>A base station is composed of two parts, a Base Transceiver Station (BTS) and a Base Station Controller (BSC). A base station is often referred to as BTS.</p> <p>The BTS is also sometimes called an RBS or Remote Base Station.</p>
Carrier recovery	A technique for extracting the RF carrier from a modulated signal so that it can be reinserted and used to recover the modulating signal
Carrier-to-interference ratio, C/I	The ratio of power in an RF carrier to the interference power in the channel
Carrier-to-noise ratio, C/N	The ratio of power in an RF carrier to the noise power in the channel
Channel	In all Avitec documentation a channel is the same as a carrier.
Coverage area	The geographical reach of a mobile communications network or system
Coverage hole	An area within the radio coverage footprint of a wireless system in which the RF signal level is below the design threshold. Coverage holes are usually caused by physical obstructions such as buildings, foliage, hills, tunnels and indoor parking garages
CSFT	(Channel Selective) Frequency Translating Repeater

---

**PRODUCT DESCRIPTION AND USER'S MANUAL**

---

CSR	Channel Selective Repeater. A repeater that operates on a specified channel within the operating band of the repeater.
dB	Decibel, A technique for expressing voltage, power, gain, loss or frequency in logarithmic form against a reference.
dB <sub>i</sub>	Decibels referenced to an isotropic antenna. A technique for expressing a power gain measurement in logarithmic form using a theoretical isotropic antenna as a reference
dB <sub>m</sub>	Decibels referenced to 1 mW. A technique for expressing a power measurement in logarithmic form using 1 mW as a reference.
Dead spot	An area within the coverage area of a wireless network in which there is no coverage or transmission falls off. Dead spots are often caused by electronic interference or physical barriers such as hills, tunnels and indoor parking garages. See also coverage area.
Distributed antenna system	A type of antenna system that is distributed or remotely located away from the transmitter. Such an antenna or series of antennas can be connected via coaxial cable, leaky feeder or optical fiber link.
DL, Downlink	The transmission path from the base station down to the mobile station
EAM	External Alarm Messaging
EDGE	Enhanced Data for Global Evolution. A technology that gives GSM and TDMA similar capacity to handle services for the third generation of mobile telecom. EDGE was developed to enable the transmission of large amounts of data at a high speed of 384 kilobit per second, or more.
EMC	Electromagnetic Compatibility The ability of a device or system to function in its intended electromagnetic environment
ERP	Effective Radiated Power
ETSI	European Telecommunications Standard Institute. The European standardization body for telecommunications
FH	Frequency Hopping. A periodic changing of frequency or frequency set associated with transmission. A sequence of modulated pulses having a pseudorandom selection of carrier frequencies.
FSR	Frequency Shifting Repeater
GND	Ground
GSM	Global System for Mobile Communication. Originally developed as a pan-European standard for digital mobile telephony, GSM has become the world's most widely used mobile system. It is used on the 900 MHz and 1800 MHz frequencies in Europe, Asia and Australia, and the 800 and 1900 MHz frequency in North America and Latin America.
Hand-over	The passing of a call signal from one base station to the next as the user moves out of range or the network software re-routes the call
ISI	Inter Symbol Interference. An interference effect where energy from prior symbols in a bit stream is present in later symbols. ISI is normally caused by filtering of the data streams
LED	Light Emitting Diode

## PRODUCT DESCRIPTION AND USER'S MANUAL

---

Link budget	A calculation involving the gain and loss factors associated with the antennas, transmitters, transmission lines and propagation environment used to determine the maximum distance at which a transmitter and receiver can successfully operate.
LMT	Local Maintenance Terminal
LNA	Low Noise Amplifier. A receive preamplifier having very low internal noise characteristics.
LO-signal	Local oscillator signal
Logical channel	A communications channel derived from a physical channel. A physical channel, i.e. RF channel, typically carries a data stream that contains several logical channels. These usually include multiple control and traffic channels.
LOS	Line of Sight. A description of an unobstructed radio path or link between the transmitting and receiving antennas of a communications system
MS	Mobile Station (e.g. mobile phone)
MTBF	Meantime Between Failures
NA	Not Applicable
NC	Not Connected
NF	Noise Figure
NMS	Network Management System
Noise figure	A figure of merit for receivers and preamplifiers representing the amount of excess noise added to the signal by the amplifier or receiving system itself. The lower the noise figure, the less excess noise is added to the signal
OFR	On Frequency Repeater
OMC	Operations and Maintenance Center. A location used to operate and maintain a wireless network
PA	Power Amplifier. A device for taking a low or intermediate-level signal and significantly boosting its power level. A power amplifier is usually the final stage of amplification in a transmitter.
PSTN	Public Switched Telephone Network, standard domestic and commercial phone service
Radio link	The equipment and transmission path (propagation channel) used to carry on communications. It includes the transmitting system, the propagation channel and receiving system
Repeater	A bi-directional Radio Frequency (RF) amplifier that can amplify and transmit a received Mobile Station (MS) signal in the MS transmit band. Simultaneously it amplifies and transmits a received Base Transceiver Station (BTS) RF signal in the BTS transmit band.
RF	Radio Frequency, 9 kHz – 300 GHz

Designation	Abbreviation	Frequencies
Very Low Frequency	VLF	9 kHz - 30 kHz
Low Frequency	LF	30 kHz - 300 kHz

---

**PRODUCT DESCRIPTION AND USER'S MANUAL**

---

	Medium Frequency	MF	300 kHz - 3 MHz
	High Frequency	HF	3 MHz - 30 MHz
	Very High Frequency	VHF	30 MHz - 300 MHz
	Ultra High Frequency	UHF	300 MHz - 3 GHz
	Super High Frequency	SHF	3 GHz - 30 GHz
	Extremely High Frequency	EHF	30 GHz - 300 GHz
RMC	Avitec® Repeater Maintenance Console Software tool to monitor and control Avitec repeaters via local or remote access		
RS232	Serial interface standard		
RS485	Serial Interface standard		
SCPA	Single Carrier Power Amplifier		
SDCCH	Slow Dedicated Control Channel. A low-speed bi-directional point-to-point control channel used to transmit service request, subscriber authentication, ciphering initiation, equipment validation and traffic channel assignment messages between the mobile and the network		
Service area	The specified area over which the operator of a wireless communications network or system provides services		
Signal-to-interference ratio, S/I	The ratio of power in a signal to the interference power in the channel. The term is usually applied to lower frequency signals, such as voice waveforms, but can also be used to describe the carrier wave. See also carrier-to-interference ratio.		
Signal-to-noise ratio, S/N, SNR	The ratio of power in a signal to the noise power in the channel. This term is usually applied to lower frequency signals, such as voice waveforms. See also carrier-to-noise ratio		
SIM card	Subscriber Identity Module Card. A small printed circuit board that must be inserted in any GSM-based mobile phone when signing on as a subscriber. It contains subscriber details, security information and memory for a personal directory of numbers. A Subscriber Identity Module is a card commonly used in a GSM phone. The card holds a microchip that stores information and encrypts voice and data transmissions, making it close to impossible to listen in on calls. The SIM card also stores data that identifies the caller to the network service provider		
SMS	Short Messaging Service. A store and forward message service available on most second generation digital systems that allows short messages (up to 160 characters) to be sent to the mobile and displayed on a small screen. The control and signaling channels are normally used to deliver these messages		
SMSC	Short Messaging Service Center		
SW	Software		
TCH	Traffic Channel. A logical channel that allows the transmission of speech or data. In most second generation systems, the traffic channel can be either full or half-rate		
Transceiver	A transmitter and receiver contained in one package. A 2-way radio or cell phone is an example of a transceiver		

---

**PRODUCT DESCRIPTION AND USER'S MANUAL**

---

Transmitter	Equipment which feeds the radio signal to an antenna, for transmission. It consists of active components such as the mixer, driver and PA and passive components such as the TX filter. Taken together, these components impress a signal onto an RF carrier of the correct frequency by instantaneously adjusting its phase, frequency, or amplitude and provide enough gain to the signal to project it through the ether to its intended target
UL, Uplink	The transmission path from the mobile station up to the base station
WDM	Wavelength Division Multiplexing. A technology that uses optical signals on different wavelengths to increase the capacity of fiber optic networks in order to handle a number of services simultaneously
VSWR	Voltage Standing Wave Ratio

# 1 Repeater Technology

## 1.1 Basic Features

A basic feature of a mobile communication system is to transmit RF signals between base stations and mobile radio equipment. If there is a blocking object such as a mountain or a building preventing the base station signal to reach the mobile equipment, a repeater can be used to extend the base station's coverage area.

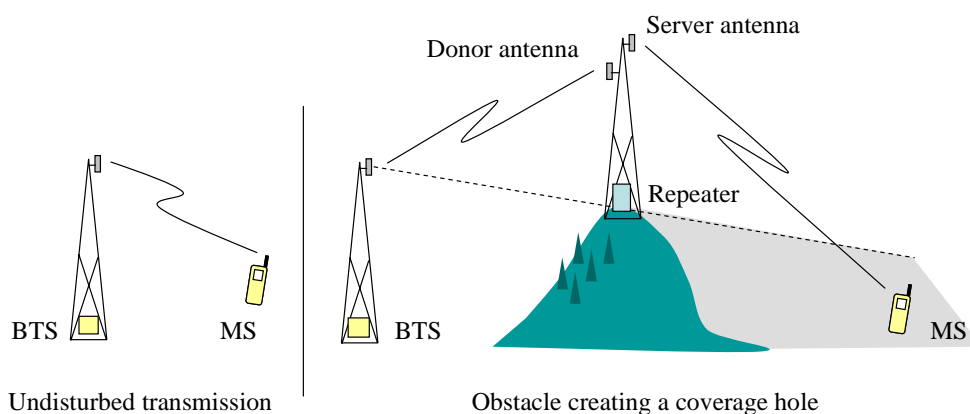

In the downlink path the repeater will pick up the signal from the existing transmitter via the donor antenna (see illustration), amplify it and re-transmit it into the desired coverage area via the server antenna. In the uplink path the repeater will receive signals from mobile transmitters in the covered area and re-transmit them back to the base station.

Other repeater applications are indoor coverage, tunnel coverage, coverage extension in low traffic areas and the possibility to install capacity in new locations without installing a new base station.

## 1.2 Repeater Types

### 1.2.1 Channel Selective Repeaters

Channel selective repeaters are mainly used for coverage of dead zones, shadows, in-building coverage or other areas with inadequate signal strength. The output power of a channel selective repeater is sufficient to cover an area shadowed by a building or other obstacle.

In a channel selective repeater each carrier is separately filtered, amplified and retransmitted. A channel selective repeater from Avitec can have 1 to 4 channels.

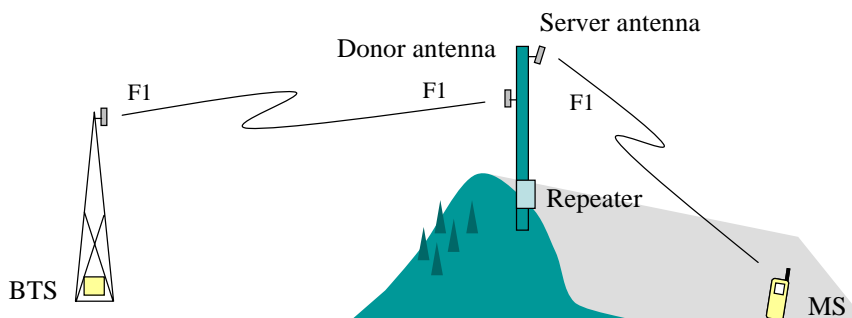

## PRODUCT DESCRIPTION AND USER'S MANUAL

A channel selective repeater system consists of one repeater unit complemented with one antenna facing the donor BTS and another antenna directed towards the coverage area. The repeater site needs to be located where the BTS signal strength is large enough to be usable by the system. Ideally the repeater's donor antenna should have line of sight (LOS) contact with the BTS antenna. If the signal strength is high enough, LOS may in some cases not be necessary.

The signal generated by the BTS is picked up at the repeater site via the donor antenna. The repeater filters and amplifies the signal before retransmitting it at the same frequency over the server antenna.

The isolation between the antennas at the repeater site has to be high in order to prevent degradation of signal quality and risk of oscillation. Ways to achieve this can be large physical separation between the antennas, usage of highly directional antennas with good front-to-interference ratio or external shielding between the antennas. Another option is to use a Frequency Translating repeater (see description below).

Channel selective repeaters may have higher output power per carrier and typically have better spurious rejection than band selective repeaters. The maximum output power per carrier can be several watts.

### 1.2.2 Band Selective Repeaters

Band selective repeaters have the same functionality as channel selective repeaters. The difference is that band selective repeaters do not separate out specific carriers but amplify and retransmit all signals within a defined frequency band.

The risk for intermodulation distortion leads in most cases to a lower output power per carrier in a band selective repeater than in a channel selective repeater.

### 1.2.3 Frequency Translating Repeaters

A frequency translating repeater provides output power levels comparable to a base station. The concept allows for high gain without the high antenna isolation required for channel selective repeaters.

The frequency translating repeater consists of two units; one donor unit and one remote unit.

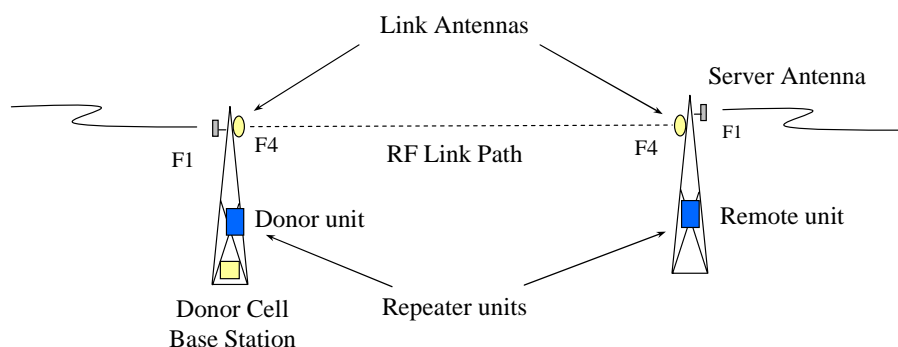

The donor unit is mounted at the base station site where the signal enters the repeater via a directional coupler. In the donor unit, the signal is translated into another frequency, the link frequency, amplified and transmitted via a link antenna. At the remote site, a link antenna picks up the signal and feeds it to the remote unit. The signal is translated back into the original frequency and retransmitted over the server antenna.

Only 2 guard channels are needed between the radio frequency and the link frequency.

The isolation between antennas at the remote site seldom needs to be more than 75dB. This value that can be achieved with a limited antenna displacement, often as low as 3 meters. The relatively modest isolation requirement allows the use of omni-directional antennas for the service area.

Important applications for frequency translating repeaters are road coverage, rural coverage or for transferring capacity from a base station to another area.

## Donor Unit

There are two types of donor units – single donor (SD) and double donor (DD).

A single donor (SD) unit has one input connector. The input signal from the BTS is split in two *within* the repeater unit. In the opposite direction – in the uplink – the signals are combined *within* the repeater before being sent to the BTS.

A double donor (DD) unit has dual inputs. This can be used in combination with a BTS that uses air combining, and hence has a separate antenna for each TRU. A double donor unit can alternatively handle two signals from two separate BTS.

## Remote Unit

There are two types of remote units – internal combining (IR) and external combining (ER).

In an internal combining (IR) remote unit output from the power amplifiers in the downlink is combined and filtered before being passed on to the server antenna. In the uplink the signal is separated within the remote unit.

An external combining remote (ER) unit has two server antenna ports and the signal is combined in the air. Since the ER model needs no combiner the output signal and gain is 3dB higher than in the IR model.

## 1.2.4 Band Translating Repeaters

Band translating repeaters are based on the same concept as frequency translating repeaters described above.

In contrast to a frequency translating repeater, which uses another frequency within the same band for the link, a band translating repeater uses another band. For instance can a repeater operating on the 900MHz band use the 1800MHz band for the link and vice versa. Other combinations are also possible.

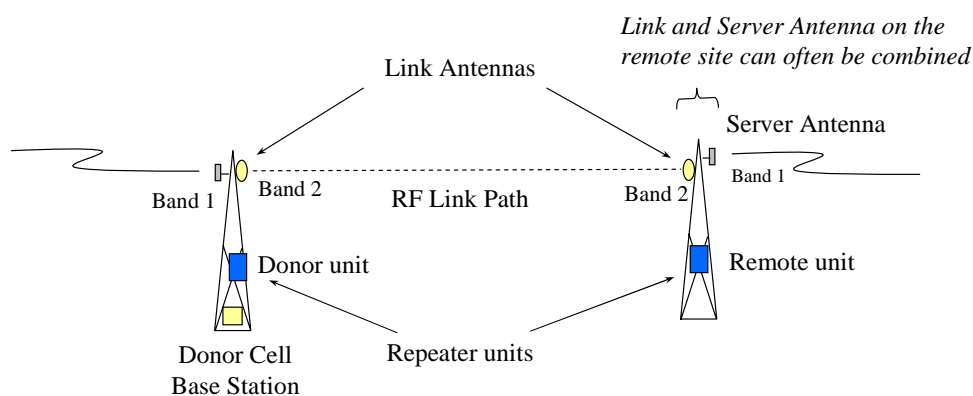

By using another band for the link the isolation between antennas at the remote site becomes very low. It is for most applications possible to use the same antenna for both the uplink and the downlink.



### 1.2.5 Fiber Fed Repeaters

The fiber fed repeater is primarily designed for coverage of tunnels and large buildings.

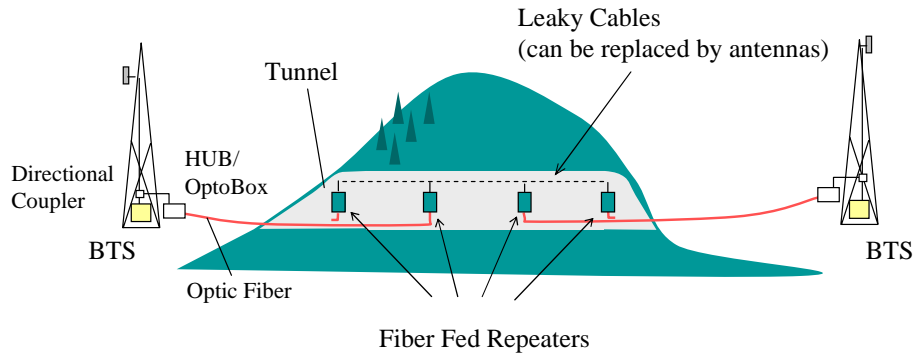

A fiber fed repeater can be either channel selective or band selective. It receives the RF signals from the base station via a unit which translates the RF signal to an optical signal and sends it to the repeater via a fiber optic cable. The repeater unit can be installed up to 20 km away from the base station.

Inside the tunnel leaky cables or antennas can be used for transmission to the mobile units.

## 1.3 Repeater Applications

### 1.3.1 Channel Selective Repeaters

#### 1.3.1.1 Shadow Coverage and Gap Filling

When there are coverage holes caused by buildings or mountains, a channel selective repeater can be used to extend coverage into the “dead zone”. The building can sometimes be used as physical shield to create the necessary antenna isolation.

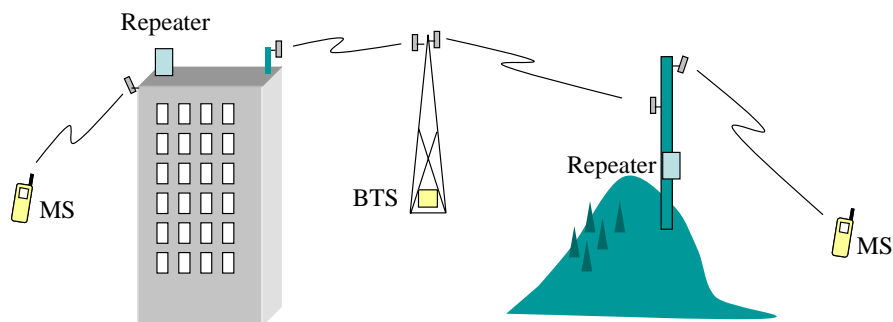

The terrain is often seen as a limiting factor when striving for flawless radio coverage. The gap-filler repeaters can be used as a complement to the network of base stations.

### 1.3.2 Frequency Translating Repeaters

#### 1.3.2.1 Low Traffic Coverage

The example shows coverage extension in an area with low traffic by using frequency translating repeaters.

A two sector BTS is extended with two frequency translating repeaters. Both donor units are mounted at the base station site and connected to the base station via directional couplers.

Each repeater has a different link frequency and transmits the frequency of the opposite base station sector, thus minimizing interference or multi-path propagation problems. A normal handover is performed between the repeater coverage area and the neighboring base station coverage area.

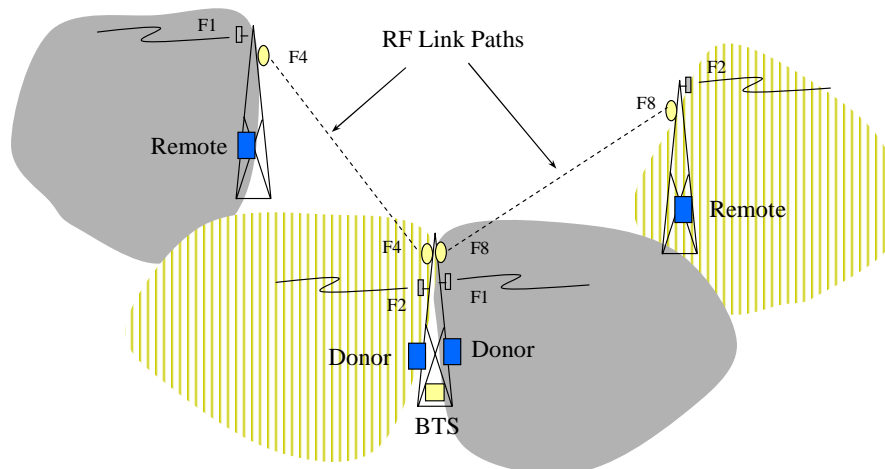

Since the installation of frequency translating repeaters requires moderate antenna isolation, remote site requirements are very moderate.

### 1.3.2.2 Highway Coverage

One two-sector BTS feeds two frequency translating repeaters, each covering an area comparable to the base station. This is a way to get maximum coverage out of the one BTS, with one connection point for transmission.

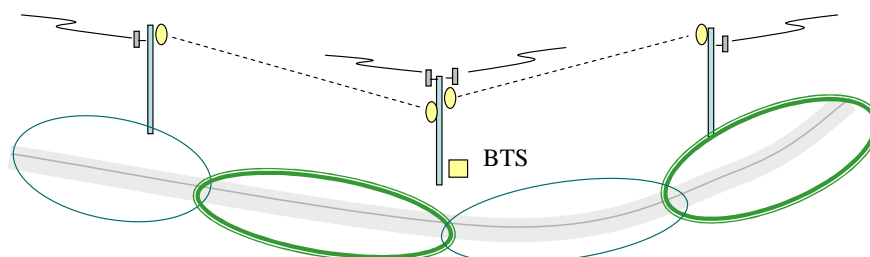

Since antenna isolation requirements are low for frequency translating repeaters, omni-directional antennas can be used at the remote sites to achieve good coverage.

### 1.3.2.3 "Fake site" – Moving Capacity

In this application the BTS is upgraded with an additional "sector" used for feeding a frequency translating repeater to cover an area up to 20km away from the BTS. This is an effective alternative when no transmission point is available in the area to be covered. The frequency translating repeater "moves" capacity from the base station site to the new location.

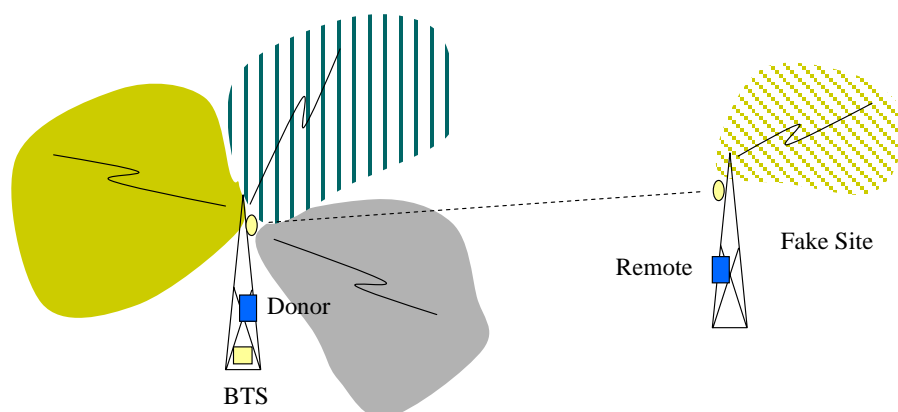

This type of installations uses takes full advantage of the high output power and high sensitivity of the frequency translating repeater.

## 1.3.3 Band Translating Repeater

A band translating repeater can be used in the same way as a frequency translating repeater if the user has access to frequencies on two different bands.

## 1.3.4 Fiber Fed Repeaters

### 1.3.4.1 Tunnel Coverage

Fiber optic fed repeaters makes it possible to cover long tunnels from one or two BTS sites nearby. The hub unit at the BTS site can feed up to 24 repeaters. The repeaters distribute the signal in the tunnel with antennas or radiating cables (leaky feeders).

Using leaky feeders is normally the most effective way to cover a tunnel, since the signal is evenly distributed along the tunnel. Achieving good coverage in a train tunnel, for instance, using antennas can be difficult as the trains tend to block signal propagation.

### 1.3.4.2 Open Area Coverage

A fiber optic fed repeater can be used in combination with a HUB or an OptoBox to move the repeater away from the base station to avoid antenna isolation problems.

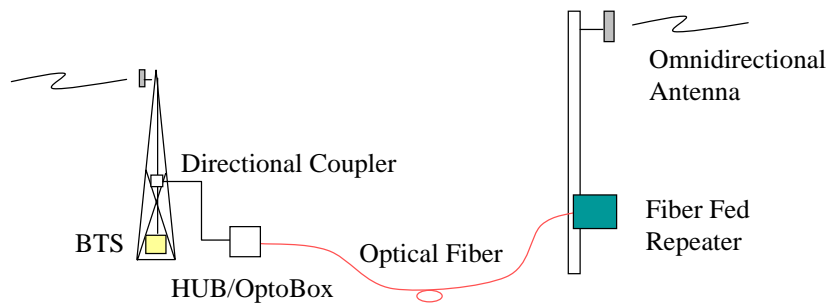

In this example a HUB/OptoBox is placed at the BTS site. The RF signal is tapped from the antenna by a directional coupler, translated into an optical signal and sent to the repeater over a fiber optic link. At the repeater site a fiber fed repeater receives the signal, translates it back to RF and sends it to the antenna. This antenna can be for instance omni-directional because the distance to the BTS is no longer a problem.

## 1.4 Software Overview

Avitec mainly supplies three different types of software; Repeater firmware, Repeater Maintenance Console and Avitec Element Manager.

### 1.4.1 Repeater Firmware

The repeater firmware is the software inside the Control Module of the repeater. It is command line based, with simple SET and GET commands. A rich variety of commands are available to control and monitor all subsystems of the repeater from a normal VT100 terminal emulation program, such as ProComm™ or HyperTerminal™. This also means that any standard laptop is able to control a repeater without additional software installed.

The repeater firmware has three main tasks:

- ♦ Set and configure parameters in the repeater, such as channel numbers, gain, power levels, and different report configurations
- ♦ Monitor and measure alarm sources, alarm parameters and repeater utilization
- ♦ Send reports and alarms to the repeater OMC

Communication with the repeater can be performed either locally on site or remotely via a modem to the built in GSM modem. For local communication a terminal with RS232 interface is needed. For remote communication a computer with a modem is needed as well as a serial communications program such as HyperTerminal™.

### 1.4.2 The RMC, Repeater Maintenance Console

RMC is an online software program with an intuitive graphical interface that simplifies control and installation of the repeater. The RMC is a graphical shell for the repeater's Control Module. It reads commands and attributes from the repeater's Control Module and displays them in an intuitive layout. This eliminates the need to learn commands and attributes for controlling the repeater.

Login to the repeater can be made locally via the LMT port or remotely via a modem. As soon as the RMC is connected it constantly polls the repeater for parameters such as power supply levels, in and out levels, temperature, traffic, etc.

The program can be installed from diskette or a CD. It is a Windows based application that runs on Windows NT4.0, Windows 2000 and Windows XP.

The Repeater Maintenance Console is available for all Avitec repeaters.

### 1.4.3 The AEM, Avitec Element Manager

AEM is a complete operations and maintenance centre for Avitec repeater networks.

The AEM takes control of the repeater once the installation at site is completed. The repeater gets integrated into the network and will be controlled by the Element Manager. During integration all repeater parameters and statuses are downloaded into a database. The database is regularly updated with all incoming alarms and reports, and will hence contain a copy of the repeater configuration so that current repeater information will be accessible without setting up communication with the repeaters.

Communication between the AEM and the repeaters are message based. This means that the operator does not have to await message delivery, but will be informed when the message is delivered to the repeater

The Avitec Element Manager is a Windows™ based application that runs on Windows NT4.0, Windows 2000 and Windows XP.

For more information please refer to the separate AEM User's Manual.

## 2 Product Description

### 2.1 Repeater Models

There are several repeater models in the Avitec GSM-EDGE program. This table provides an overview.

<b>Channel Selective Repeaters</b>		
	2 Channels	4 Channels
GSM-EDGE 900	CSR 922	CSR 924 / CSR 924H
GSM-EDGE 1800	CSR 1822	CSR 1824
GSM-EDGE 1900	CSR 1922	CSR 1924

<b>Frequency Translating Repeaters* (2 Channels)</b>				
	Donor Units		Remote Units	
	SD	DD	IR	ER
GSM-EDGE 900	CSFT922-SD	CSFT922-DD	CSFT922-IR	CSFT922-ER
GSM-EDGE 1800	CSFT1822-SD	CSFT1822-DD	CSFT1822-IR	CSFT1822-ER
GSM-EDGE 1900	CSFT1922-SD	CSFT1922-DD	CSFT1922-IR	CSFT1922-ER

\* Frequency Translating Repeaters consist of two units: one donor unit and one remote unit. There are two versions of both the donor and the remote units.

<b>Band Translating Repeaters* (2 Channels)</b>				
	Donor Units		Remote Units	
	SD	DD	IR	ER
GSM-EDGE 900	CSFT91822-SD	CSFT91822-DD	CSFT91822-IR	CSFT91822-ER
GSM-EDGE 1800	CSFT 18922-SD	CSFT 18922-DD	CSFT 18922-IR	CSFT 18922-ER

\* Band Translating Repeaters consist of two units: one donor unit and one remote unit. There are two versions of both the donor and the remote units.

<b>Fiber Fed Repeaters</b>		
	2 Channels	4 Channels
GSM-EDGE 900	CSF 922	CSF 924
GSM-EDGE 1800	CSF 1822	CSF 1824
GSM-EDGE 1900	CSF 1922	CSF 1924

## 2.2 Characteristics

These are some of the most important characteristics of the Avitec GSM EDGE repeaters. For detailed information please refer to chapter 6, Specifications, in this manual.

### 2.2.1 Channel Selective Repeaters

<b>CSR 922</b>	
System	GSM/EDGE 900MHz (E-GSM 900)
Channels	1-2 channels
Bandwidth	The operational bandwidth is 35 MHz and the channels can be set with 200 kHz channel spacing.
Output Power	Per carrier uplink and downlink: +37 dBm GSM/GMSK +34 dBm EDGE / 8-PSK average power
Repeater Gain	The repeater gain is 60 – 90 dB, adjustable in 1 dB steps
Power Supply	The power supply is 110/230 VAC, 50/60 Hz or 48 VDC, and the power consumption is 100 W typical / 200 W maximum (traffic dependent)
<b>CSR 924</b>	
System	GSM/EDGE 900MHz (E-GSM 900)
Channels	1-4 channels
Bandwidth	The operational bandwidth is 35 MHz and the channels can be set with 200 kHz channel spacing.
Output Power	Per carrier uplink and downlink: +34 dBm GSM/GMSK +31 dBm EDGE / 8-PSK average power.
Repeater Gain	The repeater gain is 54 - 84 dB, adjustable in 1 dB steps
Power Supply	The power supply is 110/230 VAC, 50/60 Hz or 48 VDC, and the power consumption is 180 W typical / 400 W maximum
<b>CSR 924 H (High Power)</b>	
System	GSM/EDGE 900 MHz (E-GSM 900)
Channels	1-4 channels
Bandwidth	The operational bandwidth is 25 MHz and the channels can be set with 200 kHz channel spacing.
Output Power	Per carrier uplink and downlink: +37 dBm GSM/GMSK +34 dBm EDGE / 8-PSK average power
Repeater Gain	The repeater gain is 63 - 93 dB, adjustable in 1 dB steps
Power Supply	The power supply is 110/230 VAC, 50/60 Hz or 48 VDC, and the power consumption is 180 W typical / 400 W maximum

**PRODUCT DESCRIPTION AND USER'S MANUAL**

---

<b>CSR 1822</b>	
System	GSM/EDGE 1800 MHz (DCS 1800)
Channels	1-2 channels
Bandwidth	The operational bandwidth is 75 MHz and the channels can be set with 200 kHz channel spacing.
Output Power	Per carrier uplink and downlink: +37 dBm GSM/GMSK +34 dBm EDGE / 8-PSK average power
Repeater Gain	The repeater gain is 60 - 90 dB, adjustable in 1 dB steps
Power Supply	The power supply is 110/230 VAC, 50/60 Hz or 48 VDC, and the power consumption is 100 W typical / 200 W maximum
<b>CSR 1824</b>	
System	GSM/EDGE 1800 MHz (DCS 1800)
Channels	1-4 channels
Bandwidth	The operational bandwidth is 75 MHz and the channels can be set with 200 kHz channel spacing.
Output Power	Per carrier uplink and downlink: +34 dBm GSM/GMSK +31 dBm EDGE / 8-PSK average power
Repeater Gain	The repeater gain is 54 -84 dB, adjustable in 1 dB steps
Power Supply	The power supply is 110/230 VAC, 50/60 Hz or 48 VDC, and the power consumption is 180 W typical / 400 W maximum
<b>CSR 1922</b>	
System	GSM/EDGE 1900 MHz (PCS 1900)
Channels	1-2 channels
Bandwidth	The operational bandwidth is 60 MHz and the channels can be set with 200 kHz channel spacing.
Output Power	Per carrier uplink and downlink: +37 dBm GSM/GMSK +34 dBm EDGE / 8-PSK average power
Repeater Gain	The repeater gain is 60 - 90 dB, adjustable in 1 dB steps
Power Supply	The power supply is 110/230 VAC, 50/60 Hz or 48 VDC, and the power consumption is 100 W typical / 200 W maximum
<b>CSR 1924</b>	
System	GSM/EDGE 1900 MHz (PCS 1900)
Channels	1-4 channels
Bandwidth	The operational bandwidth is 60 MHz and the channels can be set with 200 kHz channel spacing.



**PRODUCT DESCRIPTION AND USER'S MANUAL**

---

Output Power	Per carrier uplink and downlink: +34 dBm GSM/GMSK +31 dBm EDGE / 8-PSK average power
Repeater Gain	The repeater gain is 54 -84 dB, adjustable in 1 dB steps
Power Supply	The power supply is 110/230 VAC, 50/60 Hz or 48 VDC, and the power consumption is 180 W typical / 400 W maximum

## 2.2.2 Frequency Translating Repeaters

<b>CSFT 922</b>	
System	GSM/EDGE 900 MHz (E-GSM900)
Channels	1-2 channels
Bandwidth	The operational bandwidth is 35 MHz and the channels can be set with 200 kHz channel spacing
Output Power	Per carrier downlink (ER): +43 dBm GSM/GMSK +40 dBm EDGE / 8-PSK average power
	Per carrier downlink (IR): +40 dBm GSM/GMSK +37 dBm EDGE / 8-PSK average power
	Per carrier uplink (ER/IR): +37 dBm GSM/GMSK +34 dBm EDGE / 8-PSK average power
Repeater Gain	Downlink (ER) 78 – 108 dBm, adjustable in 1 dB steps
	Downlink (IR) 75 – 105 dBm, adjustable in 1 dB steps
	Uplink (ER) 78 - 108 dBm, adjustable in 1 dB steps
	Uplink (IR) 75 - 105 dBm, adjustable in 1 dB steps
Power Supply	The power supply is 110/230 VAC, 50/60 Hz or 48 VDC, and the power consumption is 100 W typical / 200 W maximum
<b>CSFT 1822</b>	
System	GSM/EDGE 1800 MHz (DCS 1800)
Channels	1-2 channels
Bandwidth	The operational bandwidth is 75 MHz and the channels can be set with 200 kHz channel spacing
Output Power	Per carrier downlink (ER): +43 dBm GSM/GMSK +40 dBm EDGE / 8-PSK average power
	Per carrier downlink (IR): +40 dBm GSM/GMSK +37 dBm EDGE / 8-PSK average power
	Per carrier uplink (ER/IR): +37 dBm GSM/GMSK

**PRODUCT DESCRIPTION AND USER'S MANUAL**

---

	+34 dBm EDGE / 8-PSK average power
Repeater Gain	Downlink (ER) 78 – 108 dBm, adjustable in 1 dB steps
	Downlink (IR) 75 – 105 dBm, adjustable in 1 dB steps
	Uplink (ER) 78 – 108 dBm, adjustable in 1 dB steps
	Uplink (ER) 75 – 105 dBm, adjustable in 1 dB steps
Power Supply	The power supply is 110/230 VAC, 50/60 Hz or 48 VDC, and the power consumption is 100 W typical / 200 W maximum
<b>CSFT 1922</b>	
System	GSM/EDGE 1900 MHz (PCS 1900)
Channels	1-2 channels
Bandwidth	The operational bandwidth is 60 MHz and the channels can be set with 200 kHz channel spacing
Output Power	Per carrier downlink (ER): +43 dBm GSM/GMSK +40 dBm EDGE / 8-PSK average power
	Per carrier downlink (IR): +40 dBm GSM/GMSK +37 dBm EDGE / 8-PSK average power
	Per carrier uplink (ER/IR): +37 dBm GSM/GMSK +34 dBm EDGE / 8-PSK average power
Repeater Gain	Downlink (ER) 78 – 108 dBm, adjustable in 1 dB steps
	Downlink (IR) 75 – 105 dBm, adjustable in 1 dB steps
	Uplink (ER) 78 – 108 dBm, adjustable in 1 dB steps
	Uplink (IR) 75 – 105 dBm, adjustable in 1 dB steps
Power Supply	The power supply is 110/230 VAC, 50/60 Hz or 48 VDC, and the power consumption is 100 W typical / 200 W maximum

### 2.2.3 Band Translating Repeaters

<b>CSFT 91822 (operates on 900 MHz, uses 1800 MHz for the link)</b>	
System	GSM/EDGE 900 MHz (E-GSM900)
Link Frequency Range	GSM/EDGE 1800 MHz
Channels	1-2 channels
Bandwidth	The operational bandwidth is 35 MHz and the channels can be set with 200 kHz channel spacing
Output Power	Per carrier downlink (ER): +43 dBm GSM/GMSK +40 dBm EDGE / 8-PSK average power

**PRODUCT DESCRIPTION AND USER'S MANUAL**

---

	Per carrier downlink (IR): +40 dBm GSM/GMSK +37 dBm EDGE / 8-PSK average power
	Per carrier uplink (ER/IR): +37 dBm GSM/GMSK +34 dBm EDGE / 8-PSK average power
Repeater Gain	Downlink (ER) 78 – 108 dBm, adjustable in 1 dB steps
	Downlink (IR) 75 – 105 dBm, adjustable in 1 dB steps
	Uplink (ER) 78 - 108 dBm, adjustable in 1 dB steps
	Uplink (IR) 75 - 105 dBm, adjustable in 1 dB steps
Power Supply	The power supply is 110/230 VAC, 50/60 Hz or 48 VDC, and the power consumption is 100 W typical / 200 W maximum
<b>CSFT 18922 (operates on 1800 MHz, uses 900 MHz for the link)</b>	
System	GSM/EDGE 1800 MHz (DCS 1800)
Link Frequency Range	GSM/EDGE 900 MHz
Channels	1-2 channels
Bandwidth	The operational bandwidth is 35 MHz and the channels can be set with 200 kHz channel spacing
Output Power	Per carrier downlink (ER): +43 dBm GSM/GMSK +40 dBm EDGE / 8-PSK average power
	Per carrier downlink (IR): +40 dBm GSM/GMSK +37 dBm EDGE / 8-PSK average power
	Per carrier uplink (ER/IR): +37 dBm GSM/GMSK +34 dBm EDGE / 8-PSK average power
Repeater Gain	Downlink (ER) 78 – 108 dBm, adjustable in 1 dB steps
	Downlink (IR) 75 – 105 dBm, adjustable in 1 dB steps
	Uplink (ER) 78 - 108 dBm, adjustable in 1 dB steps
	Uplink (IR) 75 - 105 dBm, adjustable in 1 dB steps
Power Supply	The power supply is 110/230 VAC, 50/60 Hz or 48 VDC, and the power consumption is 100 W typical / 200 W maximum

## 2.2.4 Fiber Fed Repeaters

<b>CSF 922</b>	
System	GSM/EDGE 900MHz (E-GSM 900)
Channels	1-2 channels
Bandwidth	The operational bandwidth is 35 MHz and the channels can be set with 200 kHz

**PRODUCT DESCRIPTION AND USER'S MANUAL**

---

	channel spacing.
Output Power	Per carrier uplink and downlink: +37 dBm GSM/GMSK +34 dBm EDGE / 8-PSK average power
Repeater Gain	The repeater gain is 38 - 68 dB, adjustable in 1 dB steps
Power Supply	The power supply is 110/230 VAC, 50/60 Hz or 48 VDC, and the power consumption is 100 W typical / 200 W maximum (traffic dependent)

## 2.3 Casing

Avitec repeaters are relatively small and have low power consumption (see table below). They are housed in a die cast aluminum box which makes them light and offers good heat conduction and waterproofing. Cooling is accomplished by convection.

The housing conforms to IP65 and NEMA 4 standards.

Dimensions, Weight and Power Consumption		
2-channel repeaters	Dimensions	470 x 340 x 145 mm
	Weight	16 kg
	Power Consumption	100W typical / 200 W maximum
4-channel repeaters	Dimensions	470 x 340 x 220 mm
	Weight	30 kg
	Power Consumption	180 W typical / 400 W maximum

2-channel models consist of a box with a lid attached by hinges. 4-channel models consist of two identical boxes, attached by hinges, where one box serves as a lid.



*2-channel repeater*



*4-channel repeater*

The repeaters can be closed by latches and locked with a key. The external connections at the bottom of the repeater are protected from unauthorized access with a cover which can be locked with the same key as the repeater.



## PRODUCT DESCRIPTION AND USER'S MANUAL

---

The repeaters are designed to be mounted on a wall, on a pole or in a 19" rack. They should always be mounted in a vertical position with the connectors facing downwards.

A label is attached to each repeater stating repeater type, frequency range and required power supply.



*Label position*



*Repeater label*

## 2.4 Connections

All connections are placed at the bottom of the repeater. Depending on type of repeater there are connections for antennas, directional coupler, fiber cable, power and external alarms.

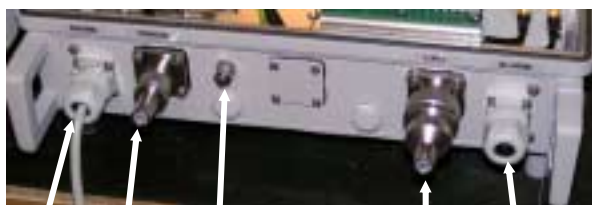

Power Donor antenna Ground Server antenna External alarms

*2-channel Channel Selective repeater*



Power Fiber connector Ground Server antenna External alarms

*Fiber fed repeater for indoor application with FC/APC fiber connector in the casing*



Power Fiber cable input Ground Server antenna External alarms



Fiber Connector, FC/APC

The fiber is pulled through the hole in the bottom panel of the repeater and connected to this connector on the opto module

*Fiber fed repeater for outdoor application with Pg 16 fitting for fiber cable insertion in the casing and an FC/APC connector on the opto module inside the repeater.*

- ◆ Antenna connections are DIN 7/16" connectors, female
- ◆ Connector to the directional coupler (frequency or band translating repeaters donor unit) is N-type, female
- ◆ Plinth connection for power is described in 4.2.6 Attach Fiber Cable
- ◆ Caution
- ◆ Un-terminated optical receptacles may emit laser radiation. Do not stare into beam or view with optical instruments.

## PRODUCT DESCRIPTION AND USER'S MANUAL



### 2.4.1.1 Fiber Connector in the Repeater Casing

Select fibre

Recommended fiber cable is single mode 9/125.

Connect the fiber cable

Connect the fibre directly to the FC/APC connector in the casing.

**Note!** Clean the fiber connector before it is connected to the Opto module, see instruction below.

**Note!** This installation is only suitable for indoor use. The IP 65 classification of the repeater casing is no longer valid.

### 2.4.1.2 Fiber Connector in the Opto Module

Select fibre

Recommended fiber cable is single mode 9/125.

Insert the fiber into the repeater into the repeater via the fitting

The casing of the repeater is equipped with a Pg connector for attachment of a corrugated hose (NW 17 mm, outer diameter 21.2 mm).

The hose, together with the Pg connector, meet the protection standard IP50. Supplemented by O-rings, the protection standard IP67 is met.

Attach the fiber to the connector in the Opto Module

Make sure the fiber is not too sharply bent. Put the excess fiber cable in soft bends in the repeater. See illustration. Fasten the cable to make sure it is not damaged when the repeater lid is closed.



**Note!** Clean the fiber connector before it is connected to the Opto module, see instruction below.

Make necessary measurements

Make necessary measurements to ensure a correct installation.

When the cable has been installed, the quality of the optical path should be checked for optical path loss and magnitude and location of any reflections. This can be done with an Optical Time Domain Reflectometer (OTDR). The total return loss should be  $> 45$  dB.

Optical reflections can degrade the noise and linearity of a fiber optic link. In particular, reflections that reach the laser can be a problem. Keep all discrete



**PRODUCT DESCRIPTION AND USER'S MANUAL**

Mount the hose to the connector	reflections to > 60 dB. The FC/APC connectors are polished to a return loss >60 dB.
Seal the hose	<p>The casing of the repeater is equipped with a Pg connector for attachment of a corrugated hose (NW 17 mm, outer diameter 21.2 mm). The hose, together with the Pg connector, meet the protection standard IP50. Supplemented by O-rings, the protection standard IP67 is met.</p> <p>Seal the hose according to the demands at hand. If the IP classification of the casing should be maintained O-rings should be used and both ends of the hose should be sealed with for instance silicon (free of acetic acid).</p>

If necessary to access the repeater end of the hose, the power plinth can be loosened (two screws) and moved forward.

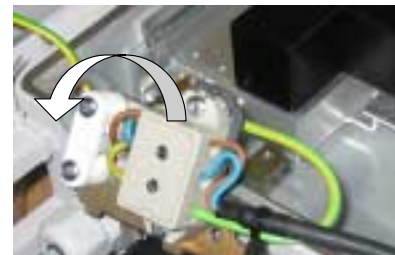
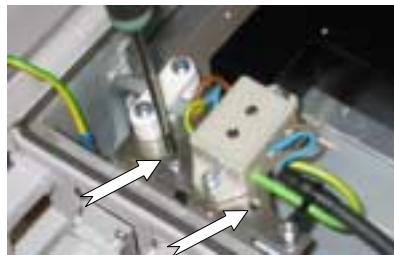

The repeater seen from the inside with the conduit marked by an arrow.

(No fiber is present in this illustration)



**Cleaning Optical Connectors**

Optical reflections from a discontinuity such as a poor connector interface appear on an RF spectrum analyzer trace as stable variations in the noise floor amplitude that are periodic with RF frequency. If the reflection is bad enough, it could impact the system performance. By far, the most common cause for a large discrete reflection is a dirty optical connector. A bit of dust or oil from a finger can easily interfere with, or block this light. Fortunately, it is very easy to clean the connector.

Be sure to use the correct procedure for the given connector. When disconnected, cap the FC/APC connector to keep it clean and prevent scratching the tip of the ferrule.

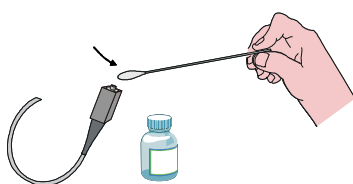

**Alternative 1**

Swipe the tip of the ferrule 2-3 times with a cotton swab soaked in alcohol. Let it air dry.



Alternative 2

Use a product specially designed for the purpose.

- ◆ Supply Power to the Repeater
- ◆ Plinth connection for external alarms is described in 4.2.9 Connect External Alarms
- ◆ Fiber connector is FC/APC. It is placed on the repeater's casing or on the opto module inside the repeater

## 2.5 Power and Back-up Battery

The repeater can be fed by 110/230 VAC, 50/60 Hz or 48 VDC (to be specified on order). The input is equipped with a surge, EMI, EMC suppression filter.



### Power Supply

There is a back-up battery. In the event of a power disruption this battery will supply the modem and the Control Module with power during enough time for the repeater to send out an alarm. The battery can be separately switched off.

For more information see 2.6.5 PSUP, Power Supply.

## 2.6 Building Blocks

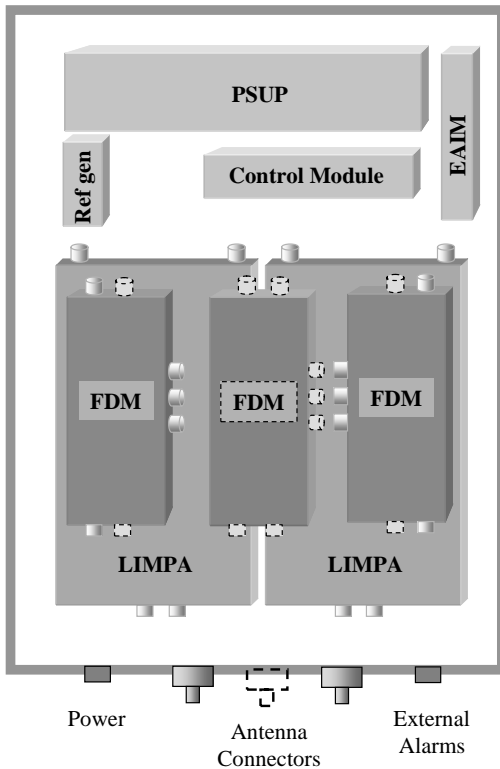

*Layout of a channel selective, frequency or band translating repeater*

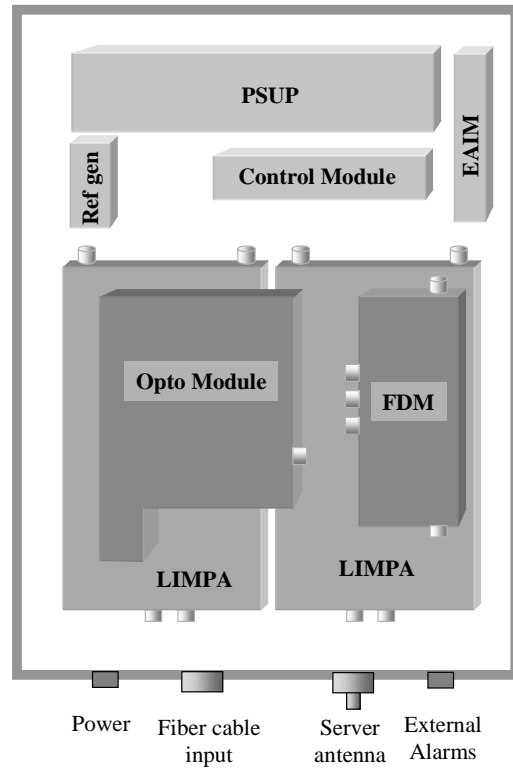

*Layout of a fiber fed repeater*

## PRODUCT DESCRIPTION AND USER'S MANUAL

---

All repeaters are realized with the same basic modules. The illustration to the left shows a 2-channel repeater. The FDM in the middle of the box is used in double donor units and in externally combined remote units for frequency and band translating repeaters. 4-channel repeaters are built up of two similar units linked by hinges to form one repeater box. In each part of a 4-channel repeater there is a splitter/combiner to distribute the signals between the LIMPA's. See also 2.7 Internal Connections.

The illustration to the right shows a fibre fed repeater. The fibre module translates the input optical signal to an RF signal in the downlink. In the uplink the translation is from RF to opto.

### 2.6.1 LIMPA, Leveling Intermediate frequency Module with Power Amplifier

The module named LIMPA, Leveling Intermediate frequency Module with Power Amplifier, consist of 4 main components:

- ◆ Power Amplifier (PA)
- ◆ Channelizer
- ◆ Synthesizer
- ◆ Microcontroller for communications with the Control Module



The PA is designed using linear temperature-compensated gain blocks and discrete RF-power transistors which are capable of delivering the required output power.

The channelizer part consists of a down-converter with IF SAW filters, an up-converter and a post amplifier. The channelizer also contains a power level and gain control unit.

The synthesizer feeds the up and down conversion mixers in the channelizer. The reference frequency for the synthesizer is generated externally in the Reference Generator. The synthesizer generates two LO<sup>1</sup>-signals used in the down- and up-conversion process. In conventional repeaters, the LO-signals have the same frequency, but for frequency translating repeaters, the LO-signals will be set on different frequencies. The synthesizer can be set with an increment of 200 kHz in accordance with GSM/EDGE channel spacing.

### 2.6.2 FDM, Filtering and Distribution Module

The module named FDM, Filtering and Distribution Module, consists of several parts:

- ◆ LNA, Low Noise Amplifier
- ◆ Splitter that divides the signal in two parts
- ◆ Combiner with high power capability that combines two signals into one
- ◆ Duplex filter for separation of the up-link and down-link RF signals with the given duplex distance. The filters consist of band-pass filters that provide excellent rejection of out-of-band signals.
- ◆ VSWR<sup>2</sup> detectors to monitor reflected power level on antenna port (downlink)
- ◆ Microcontroller for communications with the Control Module

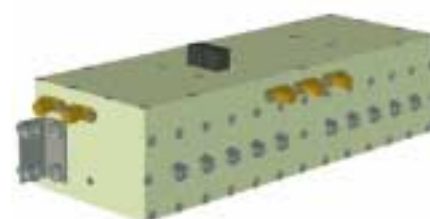

---

<sup>1</sup> Local oscillator

<sup>2</sup> Voltage standing wave ratio

### 2.6.3 Distribution Board

The distribution board serves as a distributor for power and internal communication within the repeater.



### 2.6.4 Control Module

The Control Module monitors and controls the repeater. Data is collected from various modules such as LIMPA, FDM and Power Supply utilizing a serial bus. The collected data is processed and if an error is detected the Control Module may send an alarm via Data Call or SMS using the built in wireless GSM modem to an Operations and Maintenance Center (OMC). The Control Module stores the latest 40 alarms in an alarm log.

In addition to collecting data from all modules utilizing the internal serial bus, the controller also collects status of four external alarm inputs connected to the External Interface board. The summary status of the repeater can be indicated on a relay port, available on the external interface connector. This relay can be used to indicate to external equipment if the repeater is functioning properly.



The internal serial bus utilized to retrieve the data from the various modules is master / slave based, where the Control Module is the master and all other units are slaves. The bus is based on a 4-wire RS485 multi drop bus. Communications protocol used between modules is the Avitec proprietary protocol AviNet. In case communication with a module fails, the module generates a communications alarm to the OMC.

The Control Module contains a RS232 port used for local access to the repeater. Furthermore, the GSM modem can be used for remote access.

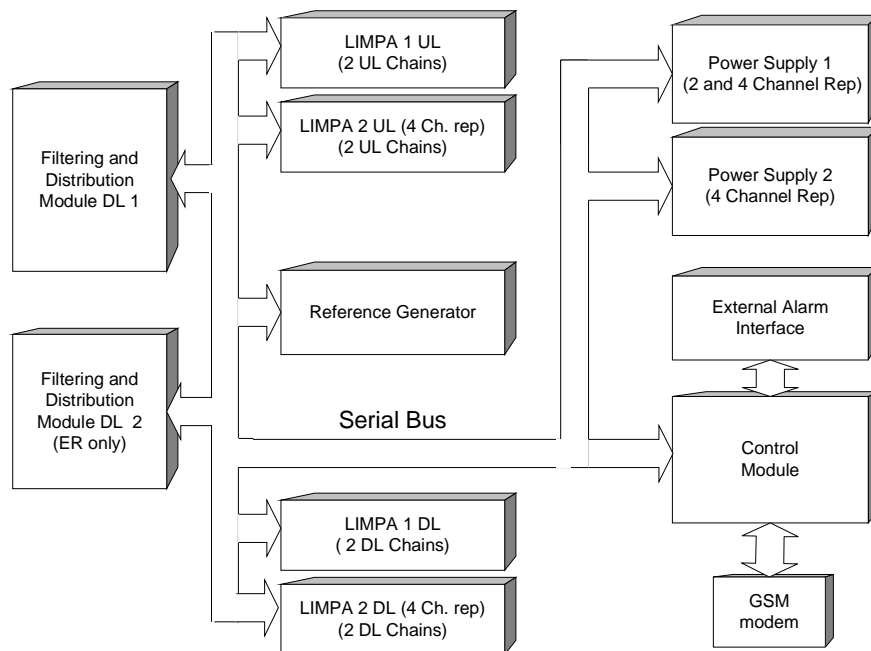

General repeater block diagram (from a controller perspective)

On regular intervals, the Control Module sends a heartbeat message to the OMC to confirm that the repeater is operational, and that the communications path between the repeater and the OMC is operational.



## PRODUCT DESCRIPTION AND USER'S MANUAL

The Control Module collects statistics on how many timeslots are utilized in the uplink path of the repeater. Once per day, a traffic report is sent to the OMC regarding the utilization of the repeater. This is used to get an estimate on how much traffic is generated from the repeater coverage area.

The Control Module includes a Real Time Clock (RTC). The RTC keeps track of at what time alarms and events occur. This RTC has its own backup battery in order to keep up proper time keeping even during long power failures.

The power supply unit contains a battery, which is used to backup the Control Module. In case of a power failure, the controller and built in wireless modem have sufficient power to report power failure alarms to the repeater OMC.

### Control Module LED

On the Control Module there are 3 LEDs to indicate the status. 1 2 3  
  

LED 1: green	
OFF	GSM Module switched OFF
Permanent ON	GSM Module Switched on, not registered on network
Slow Flash	GSM Module switched on, registered on network (approximately 1 flash per second)
Quick flash	Module switched on, registered on network, call active (approximately 3 flashes per second)
LED 2: red	
OFF	Control Module switched OFF
Slow Flash	Control Module switched on, status OK (once every 10 seconds)
Quick flash	Control Module switched on, one or more errors / alarms detected (except door status)
LED 3: blue	
OFF	Control Module switched OFF, or no one logged in
Slow Flash	Control Module switched on, nobody logged in locally OK (once every 10 seconds)
Quick flash	Control Module switched on, someone logged in remotely or locally

### 2.6.5 PSUP, Power Supply

The module named PSUP, Power Supply is dimensioned to handle a 2-channel repeater unit.

The PSUP is fed by 110/230 VAC, 50/60 Hz or 48 VDC. The PSUP generates secondary DC voltages for the repeater modules. The input is equipped with a surge, EMI, EMC suppression filter.

In the PSUP there is a backup battery module. It consists of a rechargeable battery pack, charging and supervision electronics. This backup battery will provide the Control Module and wireless modem with enough capacity to send an alarm in case of mains power failure.







The power supply module is connected to all other electronic modules via the distribution board.

## PRODUCT DESCRIPTION AND USER'S MANUAL

The power supply has a switch which allows it to be set in “on” position or in “stand by”.

### Power Supply LED

The power supply has 4 LEDs to indicate the status.

			
Mains Power	+6V	+15V	+28V

LED 1: Mains Power , green	
Slow flash	Power supply unit operating on AC or DC
OFF	Power supply unit not operating
LED 2: +6V, red	
Slow flash (every 10 seconds)	+6V power supply operating
Quick flash	+6V power supply not operating or operating with malfunction
LED 3: +15V, red	
Slow flash (every 10 seconds)	+15V power supply operating
Quick flash	+15V power supply not operating or operating with malfunction
LED 4: +28V, red	
Slow flash (every 10 seconds)	+28V power supply operating
Quick flash	+28V power supply not operating or operating with malfunction

### 2.6.6 Ref Gen, Reference Generator Module

The module named Ref Gen, Reference Generator Module consists of 4 parts: crystal oscillator, 10 power splitters, control circuitry and microcontroller for communication with Control Module.

The reference generator provides a reference signal to the synthesizers in the repeater and to the microcontrollers in the LIMPAs and FDMs. Depending on repeater type, two different crystal oscillators exist:

- ◆ On-Frequency repeaters: TXCO, temperature compensated crystal oscillator
- ◆ Frequency and Band Translating repeaters: OCXO oven controlled crystal oscillator with ultra high stability



### 2.6.7 EAIM, External Alarm and Interface Module

Four external alarm sources can be connected to the alarm module, EAIM. These sources must generate a voltage between 12 and 24 VDC. The presence or absence of this voltage will trigger the alarm depending on how alarm thresholds have been configured in the controller software.

The module can also supply +15V to external alarm sources. The maximum allowed load on this supply is 50mA.

One relay contact closure is provided for external use.

For operations of external alarms see 3.4.7 External Alarms and 4.2.9 Connect External Alarms.

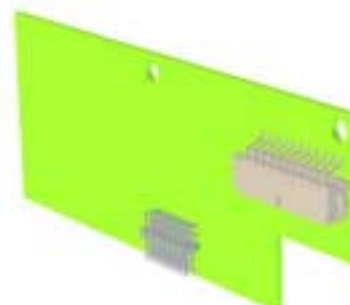

### 2.6.8 Split/Combiner

In 4-channel repeaters there are four LIMPAs. The split/combiners split and distribute the signals to the extra two LIMPAs as well as combine the signals from the extra LIMPAs.

### 2.6.9 Opto Module

The Opto Module contains both a receiver and a transmitter. The two optical signals are combined utilizing WDM technology (Wavelength Division Multiplexing). Hence only one fiber is necessary for transmission.

The Opto Module contains two alarm sources. These are alarms for transmitted and received optical signal level. The levels of the received optical signals can be monitored on-line via the RMC. This is convenient during installation and tuning of the system.



## 2.7 Internal Connections

### 2.7.1 Channel Selective Repeaters

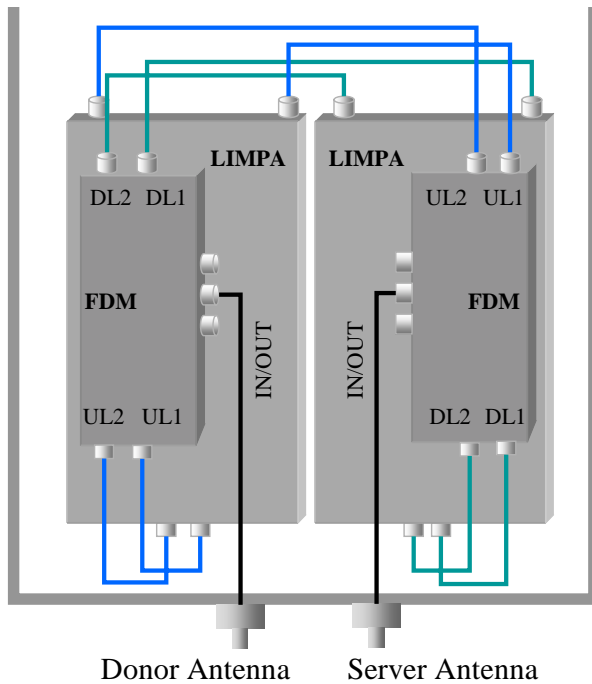

*LIMPA and FDM Connections for a Channel Selective 2-channel repeater*

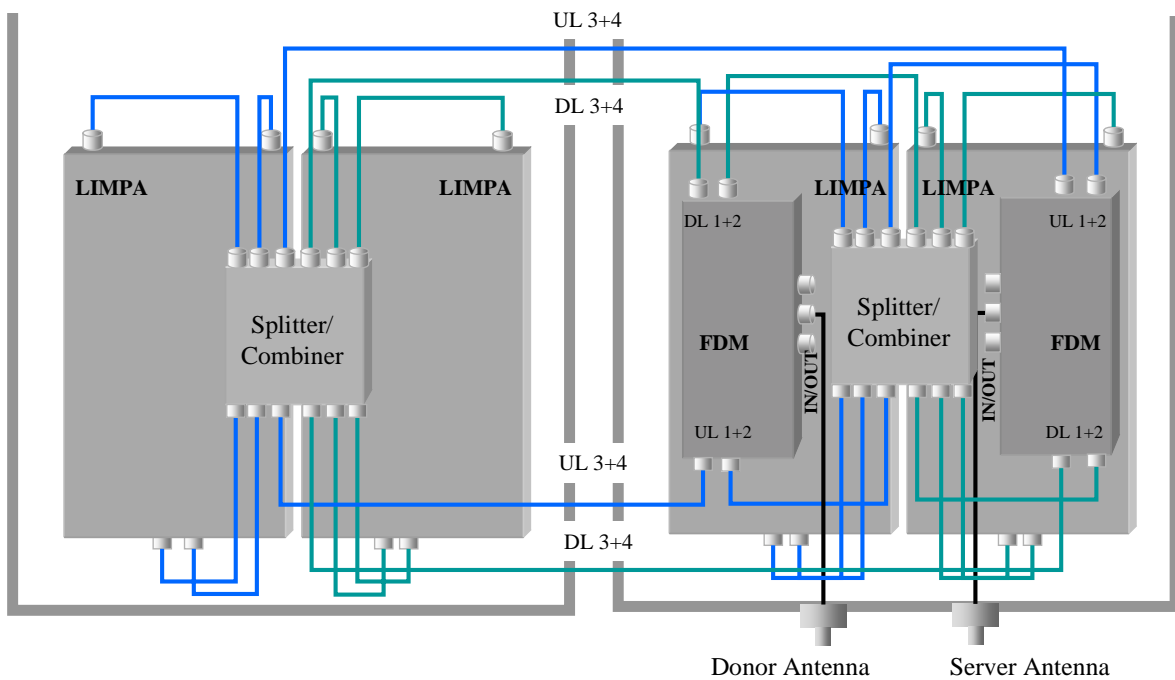

*LIMPA and FDM Connections for a Channel Selective 4-channel repeater*

### 2.7.2 Frequency and Band Translating Repeaters

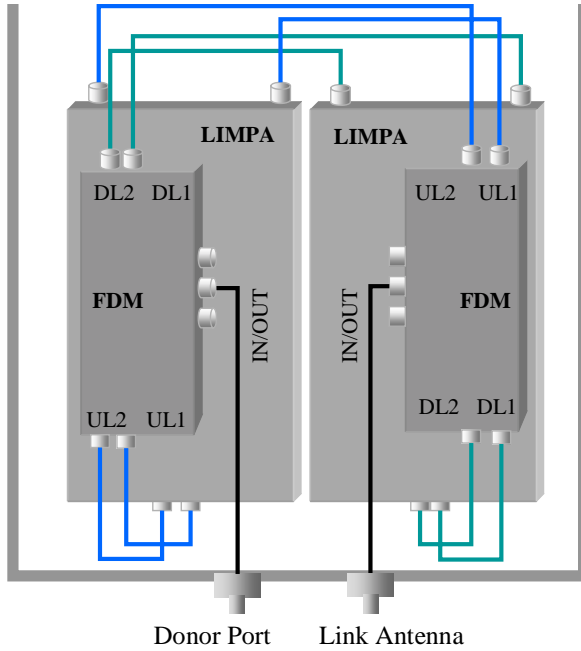

*LIMPA and FDM Connections for a 2-channel Single Donor (SD) unit*

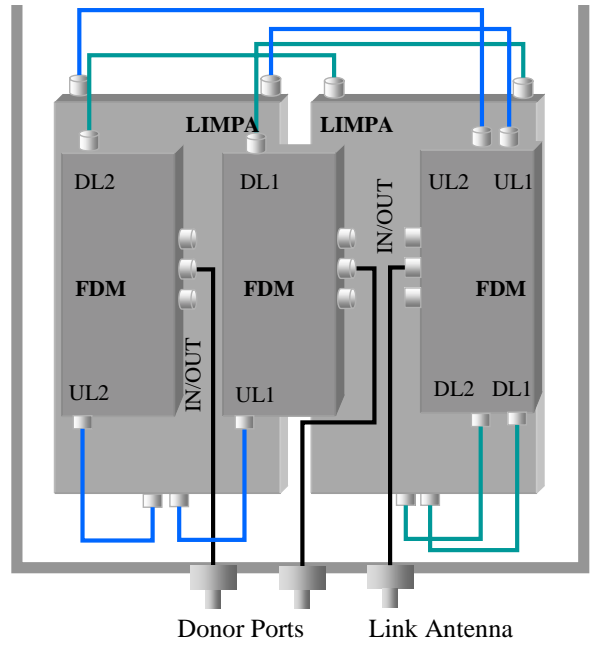

*LIMPA and FDM Connections for a 2-channel Double Donor (DD) unit*

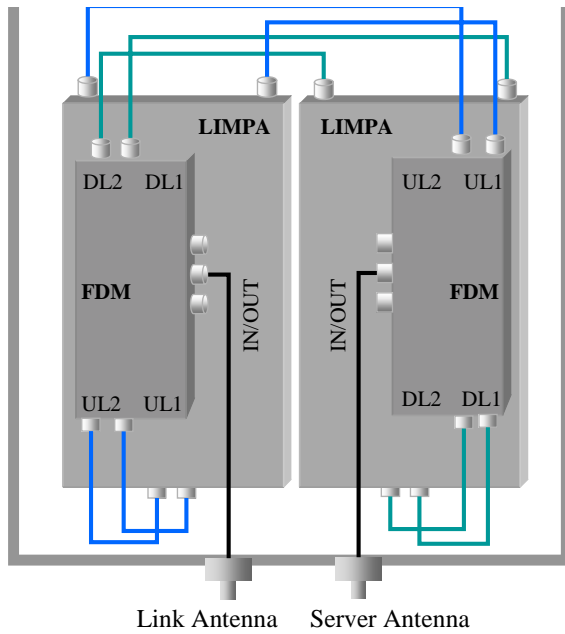

*LIMPA and FDM Connections for a 2-channel remote unit with an Internal Combiner (IR)*

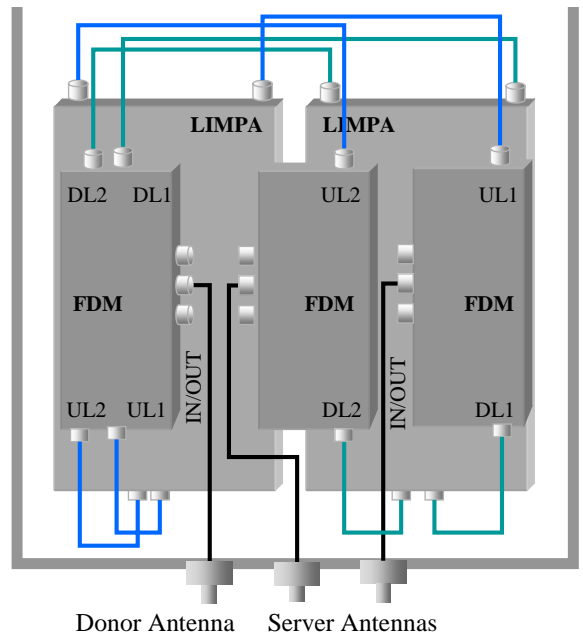

*LIMPA and FDM Connections for a 2-channel remote unit with an External Combiner (ER)*

## 2.8 Signal Paths

### 2.8.1 Channel Selective Repeaters

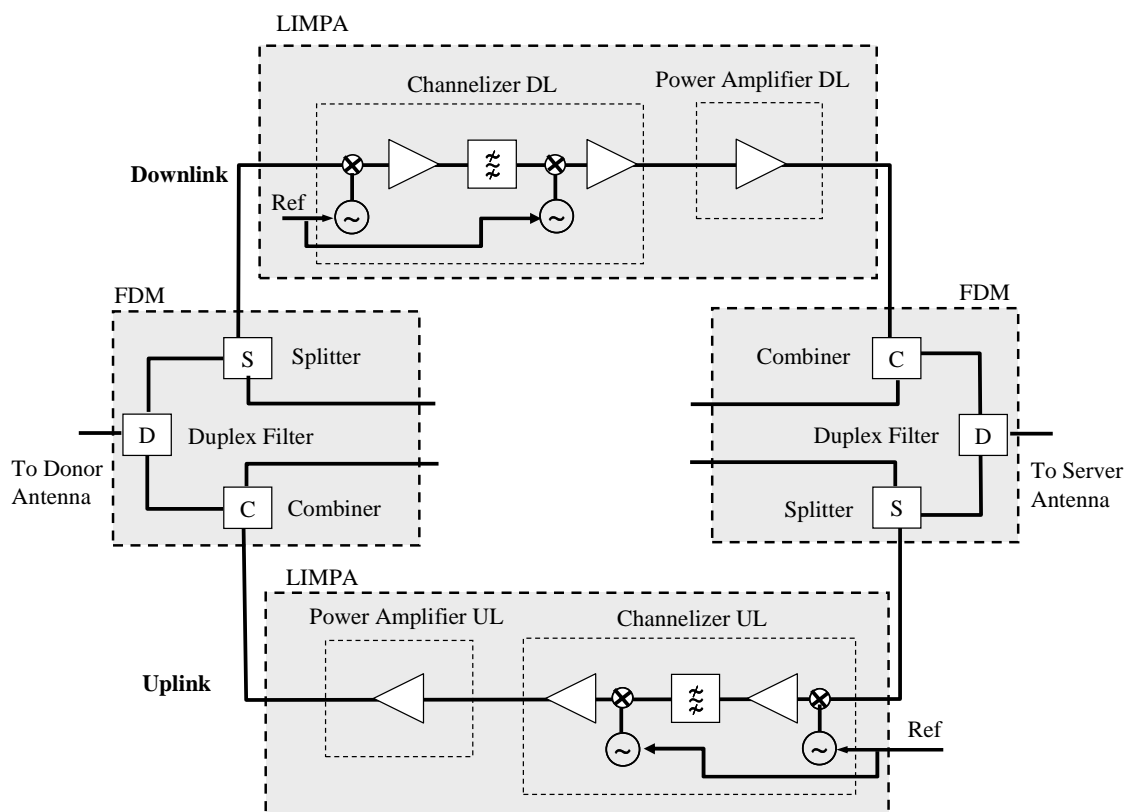

The signal from the antenna comes in to a duplex filter that separates and filters the uplink and downlink signals. After filtering, the signal goes to a splitter which distributes the signal equally to the channelizers.

Each channelizer is configured to operate on a unique narrow frequency band. In the channelizer the signal is mixed down to an intermediate frequency (IF), and is filtered on a GSM channel basis. After filtering, the signal is mixed up to the original desired frequency and amplified.

The signal is amplified in the power amplifier. It is then fed to the combiner and further on via a duplex filter to remove undesired out of band signals and intermodulated signals, to the antenna.

Four channel repeaters have the same layout as above but the signals are split/combed into four parallel flows.

### 2.8.2 Frequency and Band Translating Repeaters, Donor Unit

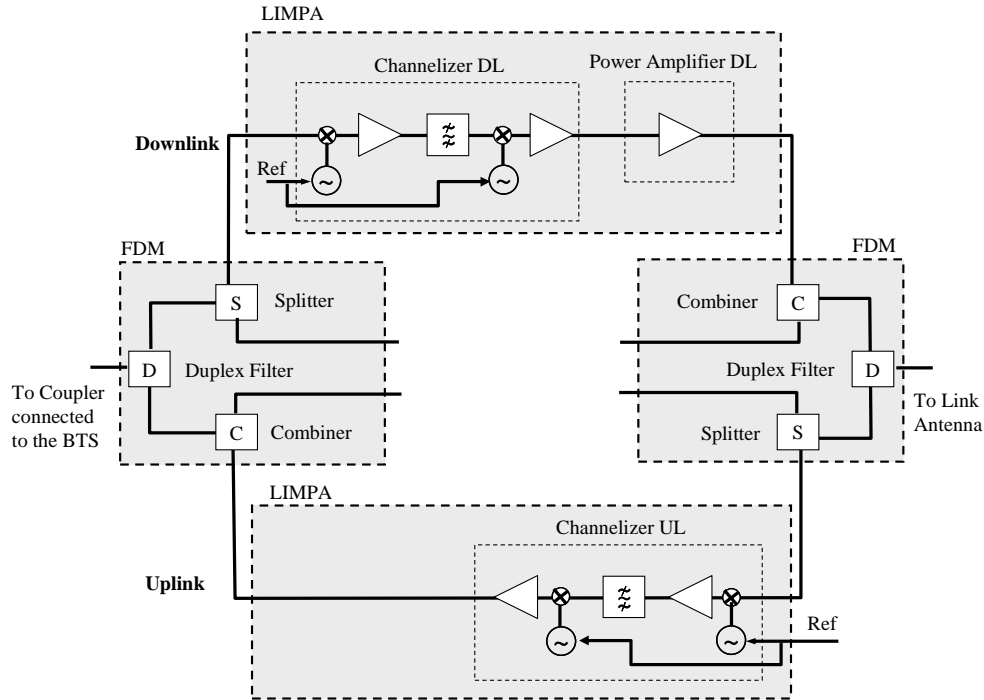

Single Donor

This illustration above shows a single donor unit where the signal from the base station is split into each channelizer in the downlink. Another alternative is the double donor where the base station uses air combining and hence has one antenna for each TRU and two signals are input to the repeater.

In the downlink the signal is mixed in the channelizer with a reference signal and transformed into another frequency – the link frequency. In the uplink the original RF frequency is restored.

There is no power amplifier in the uplink. The signal is fed directly into the base station via a 30dB coupler and hence doesn't need a high output power.

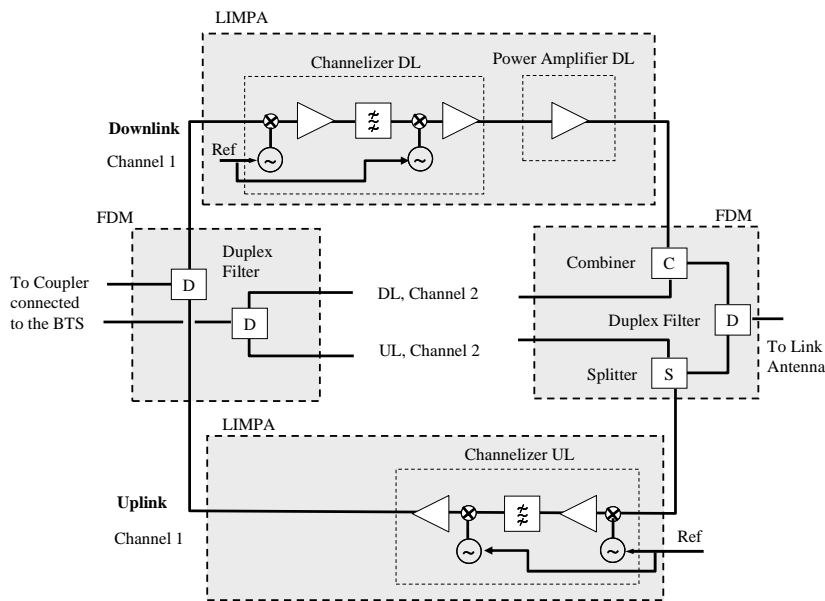

Double Donor

### 2.8.3 Frequency and Band Translating Repeaters, Remote Unit

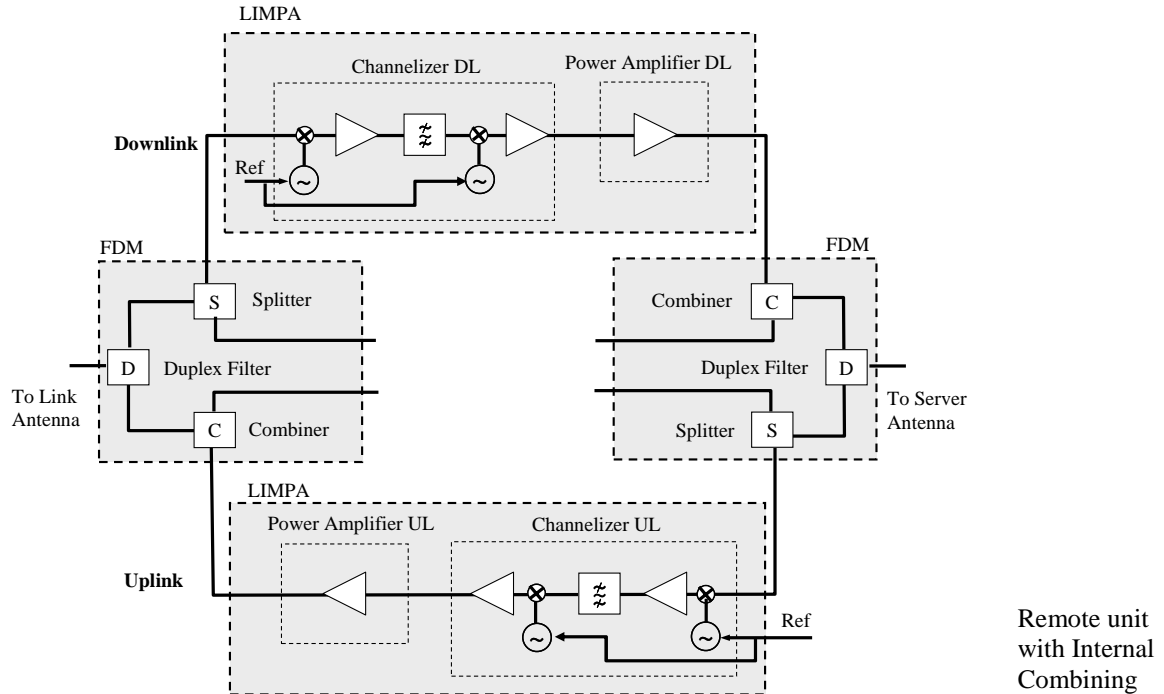

A frequency or band translating repeater has a reference generator which feeds all channelizers with a reference frequency. The channelizer contains two synthesizers, one for the down conversion from the input frequency  $F_1$  to the intermediate frequency, and one for the up conversion to  $F_2$ .

The illustration above shows a unit with internal combining, which means that in the downlink the output of the power amplifiers are combined, filtered and sent to the antenna. In units with external combining, the output from each amplifier is filtered separately and transmitted out on one antenna port each.

The output power in a -ER (external combiner) is roughly 3dB higher than in an -IR (internal combiner), since the combiner causes 3dB losses.

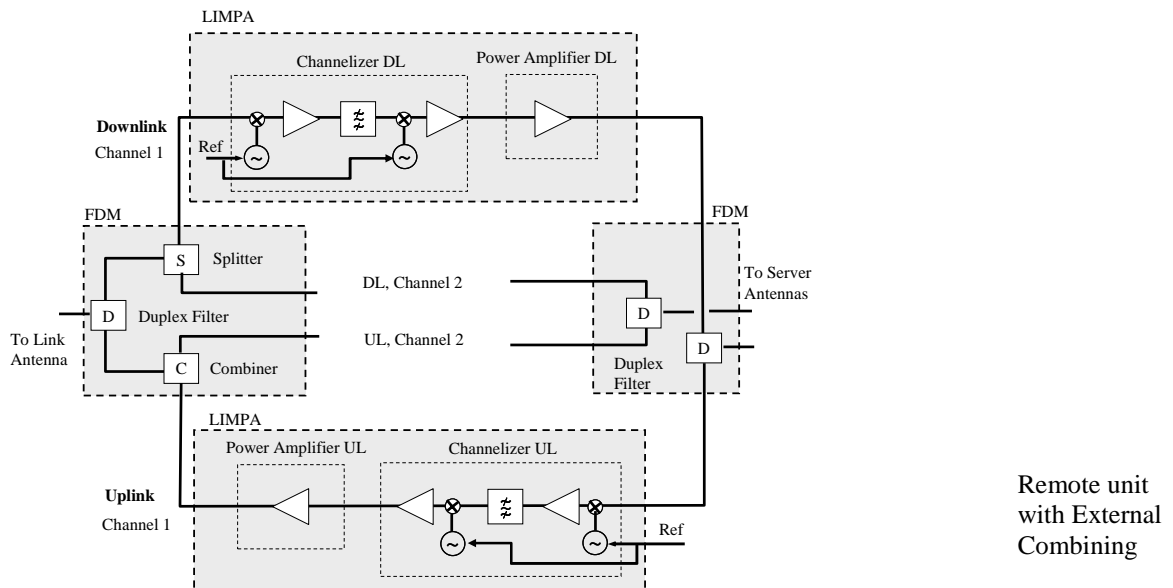

## 2.8.4 Fiber Fed Repeaters

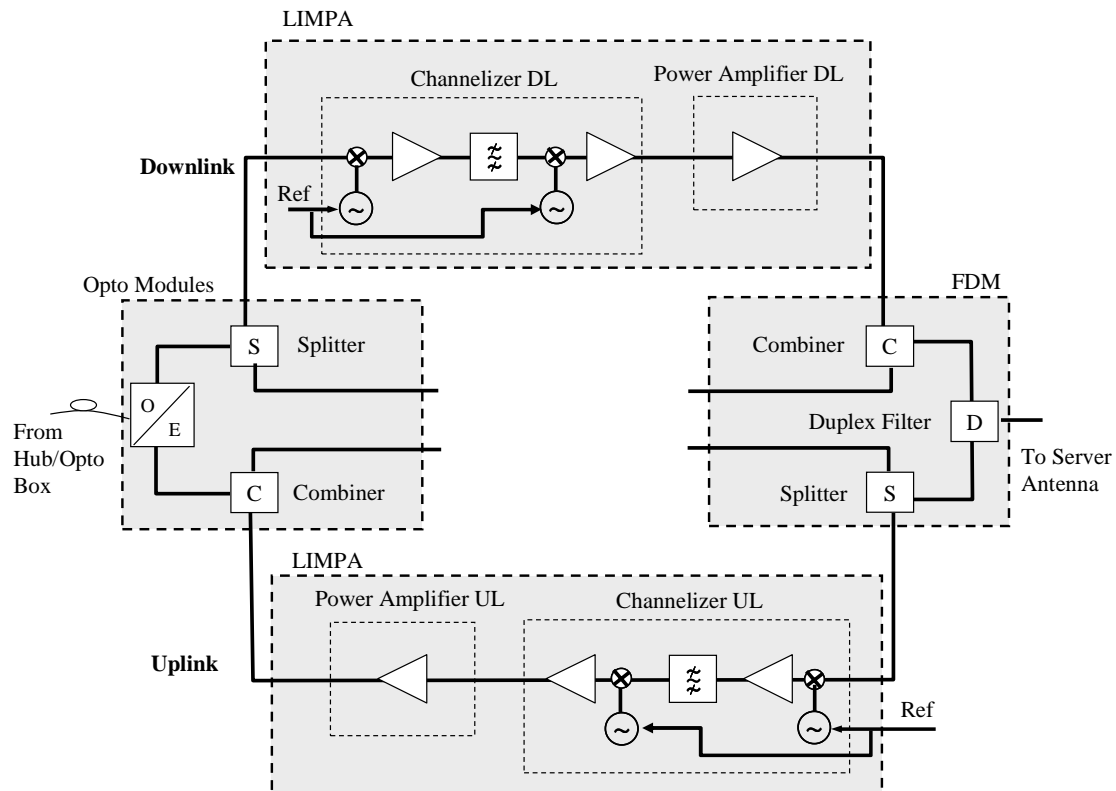

The signal from the Hub/Opto Box comes in to a converter that translates the optical signal to RF. The signal goes to a splitter which distributes the signal equally to the channelizers.

Each channelizer is configured to operate on a unique narrow frequency band. In the channelizer the signal is mixed down to an intermediate frequency (IF), and is filtered on a GSM channel basis. After filtering, the signal is mixed up to the original desired frequency and amplified.

The signal is amplified in the power amplifier. It is then fed to the combiner and further on via a duplex filter to remove undesired out of band signals and intermodulated signals, to the antenna.

In the uplink the same sequence is performed. At the end of the chain the signal is translated to an optical signal and fed back to the Hub/OptoBox.

## 3 Monitoring and Control

Avitec GSM-EDGE repeaters contain a Control Module, see 2.6.4 Control Module, which controls all parameters in the repeater, monitors alarm sources and sends reports and alarms to the AEM.

The repeaters can be accessed on site through the Local Maintenance Terminal (LMT) port or remotely over a built in modem.

When a RS232 cable is plugged in to the LMT port, there are two options for communication; terminal mode or RMC mode.

- ♦ Terminal mode is accessed by using a terminal emulation software, such as HyperTerminal™ or ProComm™. Settings should be ANSI or VT100 emulation, baud rate 9600, 8 data bits, 1 stop bit, No parity and No flow control. A simple command language is used to control the repeater in this mode.
- ♦ Repeater Maintenance Console (RMC) mode allows configuration and control of the repeater via a user friendly Windows software.

**Note!** All instructions in this chapter assumes that the repeater is controlled using the Repeater Maintenance Console, RMC.

For use of the terminal mode please refer to the document GSM-EDGE Repeater Command and Attribute Summary which contains detailed description of all attributes and commands.

### 3.1 Software Features

This first chapter contains an overview of the repeater software features. More in-depth descriptions are to be found in the following chapters.

Please also refer to the installation part of this manual for more information about repeater installation and configuration.

#### 3.1.1 User Access Levels

Only one user at a time can be logged in to each repeater. If someone is logged in locally to a repeater it will not respond to remote access attempts until the local user has logged off or has been logged off by the system after a configurable number of minutes of inactivity.



Four (4) different user accounts are available for a repeater. Two accounts have both read and write access, and two have read only access. The Avitec Element Manager has a unique username (with full read and write access).

These are the default usernames and passwords.

User Name	Password	Authority
USERNAM1	PASSWRD1	read/write
USERNAM2	PASSWRD2	read/write
USERNAM3	PASSWRD3	read only
USERNAM4	PASSWRD4	read only

The user names and passwords can be changed using the RMC. However, it is recommended to have a centralized password policy managed from the Avitec Element Manager.

## Change username or password

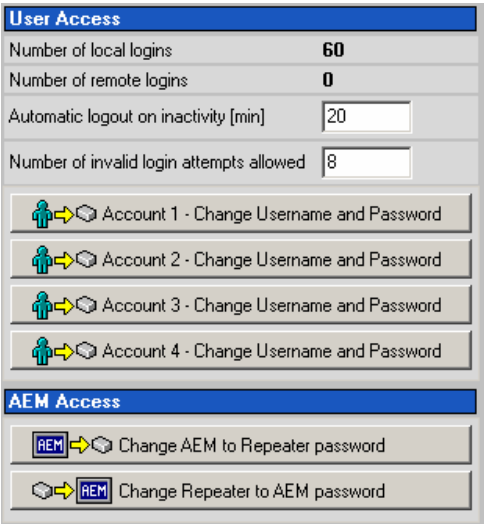
<p>Go to the User Access page</p>	 Select "Console" mode
	 Select "Configuration" window
	 Select "Communication" page
<p>Make the changes</p>	

### 3.1.2 RF-configurations, Statuses, Alarms and Levels

The firmware controls and monitors all repeater parameters. In the event of a failure, an alarm is logged in the repeater. If the repeater is controlled by the AEM, the alarm is also transmitted to the Avitec Element Manager.

The repeater can be configured to handle alarms concerning a number of different parameters. Each alarm can also be individually configured in a number of ways.

All statuses and measured levels can be read online from the RMC. This includes for instance voltage levels, RF-levels and temperatures.

### 3.1.3 Local Alarm Log

The repeater stores the latest 40 alarms in a local alarm log. The data that is stored for each alarm is the time at which an alarm occurred and the alarm information which consists of alarm source, alarm severity, alarm attributes and in some cases an additional alarm description.

If an alarm for some reason fails to be transmitted to the AEM, the repeater reads the alarm log entries and tries to retransmit the alarms a configurable number of times to the AEM or until successfully delivered to the AEM.

### 3.1.4 External Alarms

If the option for external alarms has been included four (4) external alarm sources can be connected to the repeater. These can be for instance fire alarms or external door sensors. These alarms operate on a voltage between 12 and 24VDC. The presence or absence of this voltage will trigger the alarm depending on how alarm thresholds have been configured. The external alarms have only two states – "ok" or "error".

As for all alarm sources a delay can be set that defines how many seconds an external alarm should be in error state before an alarm is generated.



### 3.1.5 Relay Connection

The repeater contains a relay, located on the External Alarm and Interface Module. This relay can be used to notify external monitoring equipment about malfunctions in the repeater

The relay can be configured to be activated on any number of external or internal alarms (while other alarm sources leave the relay unaffected).

### 3.1.6 Heartbeat Reports

On regular intervals, the repeater sends a heartbeat report to the AEM to confirm that the repeater is functioning. The heartbeat message contains information about the RF-configuration and the alarm sources. It ensures that the data communication from the repeater to the AEM is working properly.

The heartbeat interval can be set from 1 to 1440 minutes. Setting the heartbeat to 0 disables the transmission of heartbeats.

### 3.1.7 Traffic Measurements

Each uplink LIMPA contains circuitry to detect how many timeslots are active in the uplink path, i.e. detect ongoing traffic. In 15-minute intervals the total number of active timeslots in each chain is calculated and compared to the total number of timeslots. The percentage is saved in a log. Based on this information traffic reports are sent to the AEM on a configurable time of the day.

### 3.1.8 Modem Control

The repeater contains a GSM modem built in to the Control Module, utilizing the actual GSM network for remote communication with the repeater. The GSM modem should be equipped with a SIM-card when the repeater is installed at site, see 4.4.3 Set Up Remote Access.

The Control Module is responsible for enabling the power to the modem, unlocking the SIM-card, using the configured PIN-code and making sure the modem is logged in to the network correctly. Depending on network configuration and modem usage, the modem might require different modem initialization strings to work properly. This modem initialization string is set and verified during repeater setup.

At regular intervals, the Control Module polls the modem to see that the modem connection is functioning properly.

To ensure that the repeater is always remotely accessible, the controller can be configured for scheduled power cycling of the modem. This means that the modem is powered off, powered on, registered to the network and put back on line.

### 3.1.9 Battery Backup for Control Module and Modem

The repeater contains a back-up battery, mounted in the main power supply. This battery backs up the Control Module with the built in modem. In case of a power failure, the battery contains enough energy for the repeater to dial up the repeater OMC and inform about the power supply disruption.

In case the battery is not plugged in correctly, or the battery charge is too low (broken battery), an alarm is generated to the OMC.

### 3.1.10 SMS or Data Call for Alarms and Reports

The repeater can be controlled remotely via SMS or Data Call. If the repeater is configured to send alarms via SMS, it can still communicate via Data Call. However, if the repeater is configured for Data Call, incoming SMS messages will not be registered.

Please refer to 4.4.3 Set Up Remote Access for details about the remote communication using Data call and SMS.

**Note!** Avitec Element Manager does not support alarms via SMS.

### 3.1.11 Full Repeater Configuration Available

The Control Module keeps track of the exact repeater type it is controlling, and its performance parameters, including maximum uplink and downlink gain, serial number of repeater, software version in Control Module, controller hardware version, as well as hardware version of all included components.

Within the repeater the Control Module communicates with other devices using their serial number as an address. Serial numbers therefore have an important role in the repeater configuration.

### 3.1.12 Repeater Integration into AEM

When the repeater has been installed at site and the remote communication has been enabled, the repeater can be integrated to the Avitec Element Manager. This is done by the operator of the AEM. After entering the telephone number to the repeater, the AEM dials up the repeater, downloads all the repeater parameters and statuses into a database. When all parameters have been downloaded, the AEM configures the repeater with the telephone number where alarms and reports should be sent, and optionally with a secondary telephone number where the repeater can dial in case connection to primary number fails.

When heartbeat reports and alarms are sent from the repeater to the AEM also the latest information about the status and RF-configuration is included. This means that the AEM operator always has information about the current status in the AEM database (and do not need to call the repeater to find this out).

**Note!** Once the repeater is integrated to the AEM, all changes to the repeater should preferably be done from the Avitec Element Manager in order to ensure that the database always contains correct information.

### 3.1.13 Repeater ID and Tag

When the repeater is integrated into the Avitec Element Manager the repeater is assigned a repeater ID, which is a unique identifier in the repeater network. This ID is used by the AEM to keep track of the repeaters in the AEM database.

The repeater Tag can be used to give the repeater a more logical name, such as the site ID or installation place. If Tag is set during site installation, this can easily be read by the AEM during AEM integration, giving the AEM operator a clear identification of the site.

Refer to 4.4.2 Set Repeater Name (TAG) on how to set the repeater Tag.

### 3.1.14 Two separate software banks

The controller contains two different program banks. The software can be executed from one bank while new software is downloaded to the other. When new software has been completely downloaded, the execution is moved over to the new program bank. The software download can be done at site, or remotely via a modem.

See 3.8 Upgrading Repeater Firmware for description about how to upgrade the firmware.

**Note!** During software download no measurements will be made in the repeater. However, the RF transmission will still be fully operational.

### 3.1.15 Real Time Clock

The Control Module contains a battery backed-up real time clock, which will stay active even during a power failure. The real time clock is used for instance to keep track of when an alarm occurred, when to retransmit an alarm and at what time of the day to send traffic report to the AEM.

If the repeater is controlled by the Avitec Element Manager, the AEM will automatically time synchronize repeaters, to ensure that the time is always set correctly in the entire repeater network.

## 3.2 RF Parameters

### 3.2.1 Channel Assignments

Assigning channels to the repeater is easy using the Repeater Maintenance Console. Depending on the repeater's configuration there are different channel assignment options.

For channel selective repeaters with two or four channels only the repeated channels from the BTS need to be configured. For frequency translating repeaters also the link channels between donor and remote unit need to be configured. If some channels in the repeater are not used, these need to be switched off (see 4.4.1 Set up RF Configuration, for details).

Channels and links are configured using the standard ARFCN conventions.

**Note!** To ensure signal quality in the coverage area, it is important that all channels and link channels are separated by two guard channels. For example, if channel 34 is used, next allowed channel or link channel is 37.

**Note!** Always make sure that the BCCH channel is configured for chain one (1) in the repeater. The BCCH is used to monitor the output power level for alarming purposes. The BCCH is also used for timing purposes in traffic measurement.

### 3.2.2 Repeater Gain

Setting the gain in the repeater plays an important role in the repeater configuration. Since the gain affects the coverage area of the repeater, it is in most cases desired to have as high gain as possible. However, since incorrect gain settings might cause the repeater to oscillate, especially channel selective repeaters, it is important to configure the gain carefully.

The gain is adjusted by changing the attenuation of the repeater. The attenuation can be changed in 1 dB steps. If the attenuation for example is set to 30 dB, the repeater is downgraded 30 dB from its maximum performance. Maximum gain in the repeater can be read from the Product Information menu (choose Configuration/Product).

See 4.1.5 Link Budget, for more information about gain settings.



### 3.2.3 Power Level

The repeater has a constant gain in both uplink and downlink paths. The gain is set by defining the attenuation as described above.

The maximum output level from the repeater can also be defined. If the input signal amplified by the gain set exceeds the set output limit, an ALC (Automatic Level Control) loop is activated. This ALC ensures that the amplifier does not add distortion to the radio signal.

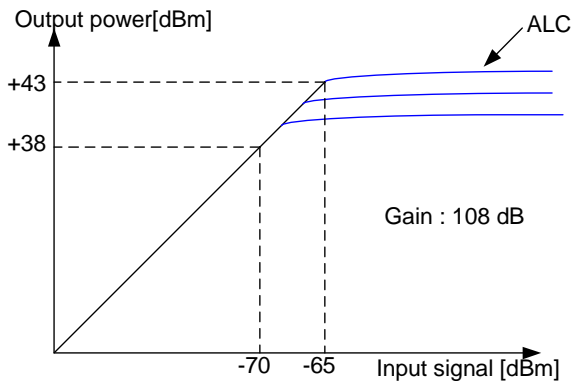

The maximum output power level is set in this RMC window. There are three values to choose from. The maximum power level can be set individually for uplink and downlink of each channel. The power level can also be set to OFF, meaning that no output power is transmitted out in the chain.

The power level in the downlink should be adjusted not to send radio signals too far into neighbouring cells, but yet be enough to cover the service area. In the uplink a signal from a user close to the repeater should not cause a transmit of too high power into the BTS antenna.

For frequency translating repeaters the signal strength of the link channel should not be set too high – just enough to reach between the donor and the remote site.

In channel selective repeaters, the uplink and downlink power levels are normally set to the same value, while the values in the frequency translating repeaters depend on the link budgets for the installation. See 4.1.5 Link Budget.

**Note!** Chains not used in the repeater must have power level set to OFF.

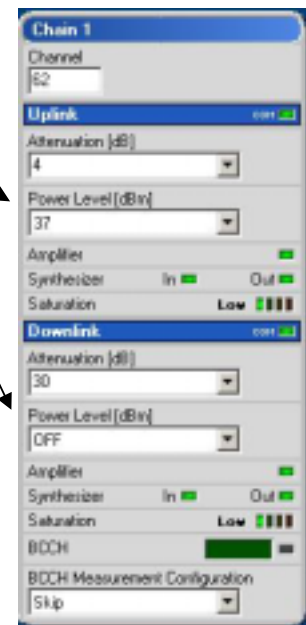

### 3.2.4 Amplifier Saturation

If the output power reaches a certain limit in the repeater the ALC is activated, as described above. For alarm and RF configuration purposes there is an Amplifier Saturation indicator and alarm parameter implemented. This indicator detects problems with the system setup or environment and can also be used during repeater installation and configuration.

The indicator has four levels:

- ♦ below optimum settings (low)
- ♦ working in the optimum range (ok)
- ♦ going into saturation (high)
- ♦ well into saturation (critical)

When the repeater is configured the BCCH gain in the downlink should be increased until the saturation indicator reaches the optimum range. This ensures that the repeater has optimized gain settings. See 4.1.5 Link Budget.



### 3.2.5 Input / Output Levels

The input and output power levels to and from the repeater are constantly monitored for each chain separately. The input level is measured directly at the input of the LIMPA. The output power is measured directly before the output of the LIMPA.

The measurable input power to the repeater ranges from -110 dBm to about -25 dBm. The output power level varies depending on repeater model. The dynamic range on the output power is roughly 25 dB, meaning that a repeater with a maximum output power of 37 dBm can detect output power levels down to approximately 12 dBm. If the output power level is lower than lowest detectable level, the RMC reports a dash.

By using these values together with the gain settings in the repeater it is possible to monitor the functionality of the amplifier chains. A too low output power in a chain might for instance indicate some problem with the LIMPA.

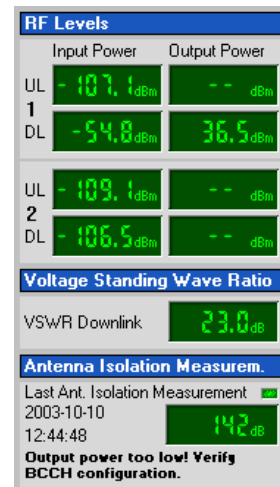

These measurements can also be useful during installation of the repeater, for example by monitoring the input signal level constantly while aiming antennas towards the donor unit detecting the direction for the maximum signal level. Monitoring the output level is helpful in determining how much the gain must be increased to reach maximum output power.

**Note!** The uplink power levels will only be displayed when there is a user in the repeater coverage area generating traffic. Also, DTX (Discontinuous Transmission Mode) enabled networks will cause the mobiles to generate traffic only when the subscriber is actually talking. This will cause the uplink meters to fluctuate a lot. The same applies to the downlink channels not configured as BCCH, since RF is only transmitted in the traffic channels if a call is handled by this TRX.

### 3.2.6 BCCH Configuration

The BCCH channel should always be configured to be transmitted through Chain 1. There are two major reasons for this:

- ♦ The repeater monitors the BCCH output power to ensure that the power level stays above a configurable threshold.
- ♦ The repeater extracts timing parameters for the traffic measurement system from the downlink BCCH signal configured in Chain 1.

There are a number of different ways to monitor the BCCH. Each chain can be configured in three different ways:

Required	the output power must be present on this chain
Either	the output power must be above the threshold on this or any of the other chains configured
Skip	the output power is not measured on this chain

By default, the repeater is configured with “Required” in chain 1, and “required” also in the other chains. This means that if the BCCH drops in chain 1, an alarm is generated.



Examples of how to use the BCCH configuration:

- ♦ Two 1-channel sectors are to be transmitted through a frequency translating –ER repeater, where each sector is transmitted out via separate antennas. Both channels need to have a constant output power above the threshold. In this case both chains should be configured as ”Required”.
- ♦ The base station supports BCCH “fall-over”, where the BCCH will automatically switch over to TRX 2 in case the default BCCH TRX fails. Configuring the repeater as “Either” will cause the repeater to require output power on chain 1 or 2. In this case the BTS will generate an alarm, why we do not need an alarm in the repeater OMC as well.

**Note!** When the BCCH jumps to chain 2, the traffic synchronization will be lost. This means that snapshot traffic data (number of timeslots used per frame) will be less accurate, but total traffic measurement will stay correct.

### 3.2.7 Return Loss (VSWR)

The server FDMs contains circuitry to measure the reflected power levels back from the connected server antenna cables. A too high level on the reflected power generates an alarm.

Typical reasons for a high reflected power level can be an antenna connector being improperly tightened, a broken cable or a broken antenna.

Frequency Translating –ER repeaters contain two FDM’s, one for each server antenna, and hence two reflected power levels are measured. All other repeater types contain only one server FDM.

The level for when to generate an alarm is configurable as number of dB’s difference between forward and reflected power levels. Default level is 10 dB, and normally this value should not be changed.

### 3.3 Hardware Identification

#### 3.3.1 Repeater Type Identification

When a login to a repeater is made using the Repeater Maintenance Console, the RMC detects the repeater type and adjusts the user interface correspondingly. The same RMC can be used for all repeater types.

#### 3.3.2 Hardware Inventory

A repeater contains a number of different building blocks such as FDMs, LIMPAs, Power Supply, etc. Some of these are so called active devices meaning that they contain a micro controller used for monitoring of module parameters. Some are passive devices, for example the distribution board.

The Control Module communicates with the active devices using a master/slave configuration, where the Control Module is the master and the active devices are slaves. Each active device uses its serial number as an address. A slave only replies to requests with the correct address information.

During production the repeater is configured with all the serial numbers of all the devices in the system. For passive devices, the article number of the device is added. Once the system is configured, the Control Module polls all the active devices for article numbers and production information as well as software versions and statistics of the active devices.

Via the RMC the full repeater inventory can be read, including statistics of the active devices.

Repeater TAG

Repeater ID

List of all hardware in the repeater

Control Module ID

List of all active devices

Information about a selected device

The screenshot shows the 'Configuration' window with several sections:

- General:** Model: CSR924, Serial number: 4040, TAG: RFID-2339, ID: 00-00-0000, Manufacturing info: BH, System init. time: 2003-11-26 10:40:00, System up time: 0 days, 2 h, 3 m, 29 s, Current Date: 2003-11-27, Current Time: 09:20:28.
- Control Module:** Serial number: 3XRS, Hardware version: H311001B, Software version: 1.0 Beta3, BIOS version: 1.1, PLD version: 11, Controller prod. date: 2003-11-20 13:45:00, Software build date: Nov 7 2003 11:04:45.
- RF Parameters:** Maximum Gain [dB]: UL: 84.0 DL: 84.0, PreAmp Gain [dB]: UL: 12.0 DL: 12.0, Loss after PA [dB]: UL: 8.0 DL: 8.0, Lowest Detectable Output [dBm]: UL: 15.0 DL: 15.0.
- Hardware Device List:** A table listing various components like LIMPAs, FDMs, and Distribution Boards.
- Active Device List (Click item for details):** A table listing active devices with their serial numbers and article numbers.
- Detailed Information about selected Device:** Shows details for a selected device (Serial No: 3ZYV, Article No: E401031B, Description: LIUL), including SW Version, Manufacturing Info, Module initialization, Uptime since reset, and Reset counters.

#### 3.3.3 Replacing/Reconfiguring Hardware Modules

If a module needs to be changed it is important to update the repeater with the new hardware information. For active devices this is crucial to ensure communication between the new module and the Control Module. For all devices it gives an up-to date inventory of the entire network.

The hardware is reconfigured by logging in to the repeater via the RMC and switching to Terminal Mode. If the change concerns an active or passive device the command syntax varies slightly.

**Format:**

```
HARDWARE REPLACE <OldSNO> <NewSNO> [Article Number]
```

<OldSNO> is the serial number of the module that has been removed

<NewSNO> is the serial number of the new module

[Article Number] is used if a passive module, such as a distribution board or external interface board is changed.

*Example 1:*

```
HARDWARE REPLACE 2J3A 3ASA
```

replaces the broken module 2J3A with the new module 3ASA.

*Example 2:*

```
HARDWARE REPLACE 3AZC 3EEF J691001A
```

replaces the old module 3AZC with the new module 3EEF, with article number J691001A.

If the repeater is controlled by the Avitec Element Manager a refresh of the repeater should be initiated from the AEM as soon as the hardware has been replaced and the repeater configuration has been updated. This ensures that the AEM also contains the latest hardware configuration.

**Note!** The current hardware configuration can be displayed in terminal mode by entering the command `HARDWARE` without parameters.

## 3.4 Alarm System

The Avitec repeaters contain a number of different alarm sources, both analog and digital, to ensure that the repeater works with desired performance.

### 3.4.1 Alarms and End of Alarms

When the Control Module detects a failure in the repeater, an alarm is transmitted to the Avitec Element Manager, informing the operator about the error condition. When the alarm has ceased, an end of alarm is sent to the AEM, stating that the alarm source is now OK.

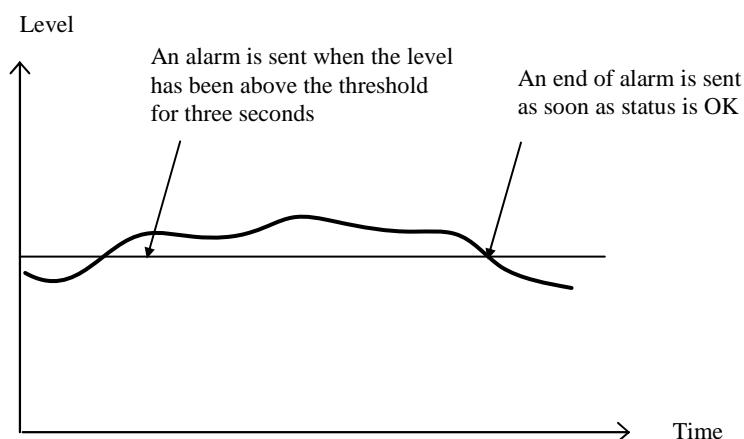

Each alarm and end of alarm updates the AEM database with the latest status of the alarm source, ensuring that the AEM operator always has the correct repeater status in the system.

- ◆ To generate an alarm a number of consecutive measurements must first show an error state.
- ◆ To generate an end of alarm only one OK measurement is needed.



PRODUCT DESCRIPTION AND USER'S MANUAL

Alarms can be of five different severity levels

Severity Level	Description
!! Critical	A critical error has occurred which affects the functionality of the repeater. This type of alarm requires immediate action.
! Major	A major error has occurred. This type of alarm should be investigated within a short time.
! Minor	A minor error has occurred. This type of alarm should be investigated, but is not urgent.
⚠ Warning	Something has occurred that does not affect the operation of the repeater but may be important to notice. For example, someone has logged on to the repeater.
OK Cleared	A cleared alarm. This is the end of alarm.

**Note!** User related alarms (as described in 3.4.6 Alarm Sources) do not send an end of alarm.

### 3.4.2 Alarm Acknowledgements and Retransmissions

The 40 latest alarms and end of alarms are stored in the repeater's local alarm log. In case an alarm is not acknowledged (see below), the alarm will be retransmitted to the AEM after a configurable number of minutes. The retransmission will be repeated a configurable number of times. Default retransmit interval is 10 minutes. Default number of retries is three.

Number of retransmissions

Repetition cycle

#### Alarm log

Repeater Message No

Date/Time

Description

Attribute/Alarm Source

Severity

Class

Alarm acknowledged

Acknowledgement using RMC

Msg. No.	Date/Time	Description	Attr.	Severity	Class	Ackn.
00003	2003-11-26 09:32:50	End of error in communication between controller...	CCM	Cleared	Equipment	✓
00002	2003-11-26 09:32:57	End of error in communication between controller...	CCM	Cleared	Equipment	✓
00001	2003-11-26 09:32:26	End of error in communication between controller...	CCM	Cleared	Equipment	✓
00070	2003-11-26 09:54:46	Error on communication between controller and rh...	CCM	Critical	Equipment	✓
00071	2003-11-26 09:54:44	Error on communication between controller and rh...	CCM	Critical	Equipment	✓
00072	2003-11-26 09:54:22	Error on communication between controller and rh...	CCM	Critical	Equipment	✓
00076	2003-11-26 09:48:30	End of error in communication between controller...	CCM	Cleared	Equipment	✓
00075	2003-11-26 09:48:37	Error on RXCH output level	PDL	Warning	Quality of s...	✓
00074	2003-11-26 09:48:34	End of error in communication between controller...	CCM	Cleared	Equipment	✓
00077	2003-11-26 09:48:33	End of error in communication between controller...	CCM	Cleared	Equipment	✓
00072	2003-11-26 09:34:04	Error on reflected power downlink	WRD	Critical	Quality of s...	✓
00071	2003-11-26 09:34:03	Data speed	DDO	Warning	Equipment	✓
00070	2003-11-26 09:34:01	Error on communication between controller and rh...	CCM	Critical	Equipment	✓
00069	2003-11-26 09:34:00	Error on communication between controller and rh...	CCM	Critical	Equipment	✓
00068	2003-11-26 09:33:37	Error on communication between controller and rh...	CCM	Critical	Equipment	✓
00066	2003-11-25 13:23:42	Error on reflected power downlink	WRD	Critical	Quality of s...	✓
00067	2003-11-25 13:23:41	Data speed	DDO	Warning	Equipment	✓
00066	2003-11-25 13:23:39	Error on communication between controller and rh...	CCM	Critical	Equipment	✓
00065	2003-11-25 13:23:38	Error on communication between controller and rh...	CCM	Critical	Equipment	✓
00064	2003-11-25 13:23:36	Error on communication between controller and rh...	CCM	Critical	Equipment	✓
00062	2003-11-25 13:22:01	Changes made by user logged in	CLR	Minor	Equipment	✓
00061	2003-11-25 13:22:00	User USERNAME1 logged out	LGO	Minor	Equipment	✓
00060	2003-11-25 13:21:59	User USERNAME1 logged in	ULI	Minor	Equipm...	✓
00049	2003-11-25 13:21:37	Error on reflected power downlink	WRD	Critical	Quality of s...	✓
00048	2003-11-25 12:58:59	User USERNAME1 logged out	LGO	Minor	Equipment	✓
00047	2003-11-25 12:49:29	User USERNAME1 logged in	ULI	Minor	Equipment	✓

### 3.4.2.1 Alarm Acknowledgement using the RMC

Each alarm can be manually acknowledged using the Repeater Maintenance Console. However, if the repeater is controlled by the Avitec Element Manager, a manual acknowledgement of the alarm means that the AEM will not be aware of the change in the repeater status.

### 3.4.2.2 Alarm Acknowledgement using the Avitec Element Manager

If the repeater is integrated to and controlled by the Avitec Element Manager, an alarm is considered acknowledged when the repeater has dialed the AEM, logged in to the AEM and delivered the alarm. Once delivered to the AEM, the acknowledgement of the event is taken care of locally at the AEM, why no dial-back needs to be performed to acknowledge the alarms in the repeater.

### 3.4.2.3 Alarm Acknowledgement using SMS

If the repeater is configured to send alarms using SMS, alarm acknowledgement can be made in two different ways.

- ♦ the alarm is acknowledged as soon as the alarm SMS is successfully received by the Short Message Service Centre
- or
- ♦ the alarm is acknowledged by sending a special alarm acknowledgement SMS back to the repeater from the alarm destination.

Choose Configuration./AEM Reports pick one alternative from the drop-down menu

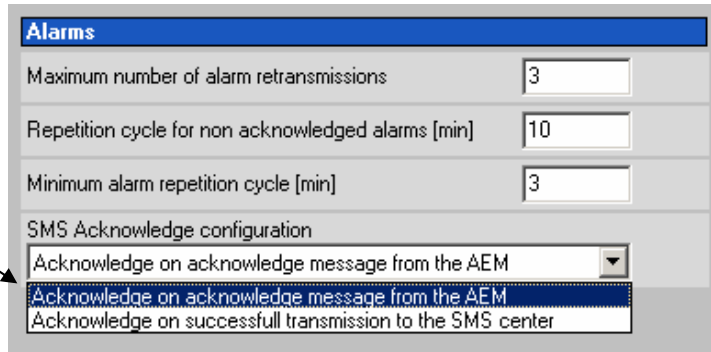

All alarms transmitted from the repeater contain a message number. Acknowledgement of an alarm is done by sending an SMS to the repeater containing this message number.

**Note!** Only the defined “Primary SMS address” can acknowledge alarms.

The table below displays the format of alarm acknowledgement messages.

Message field	Format	Description
Repeater ID	XX-YY-ZZZZ	ID of the repeater that the message is intended for
Message number	NNNNN	Message number from the main address (any 5-digit number)
Command	ACT	Action command
Argument	ACK	Acknowledge action
Argument	MMMMM	Message number of the alarm message to acknowledge

The message fields are separated with blanks.

For example, sending an SMS to the repeater with the text

01-42-4711 00242 ACT ACK 00023

will acknowledge alarm number 00023 from repeater 01-42-4711.

### 3.4.3 Alarm Repetition

As soon as the repeater detects an alarm or an end of alarm, a connection to the Avitec Element Manager is established and the alarm event is reported. Many alarm sources are configured for the error to be present during three seconds before an alarm is generated. End of alarm is triggered as soon as an OK state is detected.

If an alarm should constantly toggle between OK and ERROR the communications interface might be blocked. To prevent this there is a parameter called Minimum Alarm Repetition. This parameter defines how many minutes must elapse before a new alarm can be transmitted from the same alarm source.

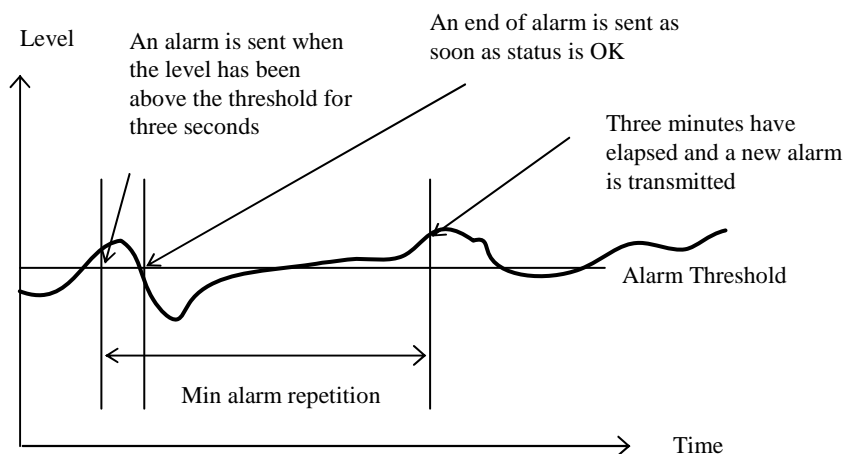

The example shows an alarm source with an upper threshold, and a fluctuating level around the alarm threshold. In this example, we will receive the first alarm as indicated, and also a new one that will be transmitted after three minutes, when the minimum alarm repetition period has elapsed.

Minimum time between alarms

Alarms	
Maximum number of alarm retransmissions	<input type="text" value="3"/>
Repetition cycle for non acknowledged alarms [min]	<input type="text" value="10"/>
Minimum alarm repetition cycle [min]	<input type="text" value="3"/>

### 3.4.4 Relay Output

The repeater can be ordered with a relay option. The relay, located on the External Alarm and Interface Module, can be used to indicate to external alarm equipment the summary status of the repeater. Each alarm source can be configured to be affecting the relay or not, see next section. If one or more alarm sources in the repeater are in error, the relay will be opened.

If the repeater is part of an antenna distribution system in for example a tunnel, all tunnel equipment can be monitored from one central location using current loops. This means that the tunnel service engineers can independently from the Avitec Element Manager staff be informed about the repeater status.

Each alarm source can be individually configured if the relay should be affected or not.

**Note!** The relay status is not affected by the login / logout alarm parameters.

For installation testing purposes, it is possible to test the open / close function of the relay. This test procedure makes sure the relay is closed for 2.5 seconds, then opens for 10 seconds, and finally closes for 2.5 seconds before going back to original state.

### 3.4.5 Alarm Configuration

A number of different parameters can be configured for how the alarms are transmitted to the repeater OMC. Each alarm source can also be individually configured in a number of different ways.

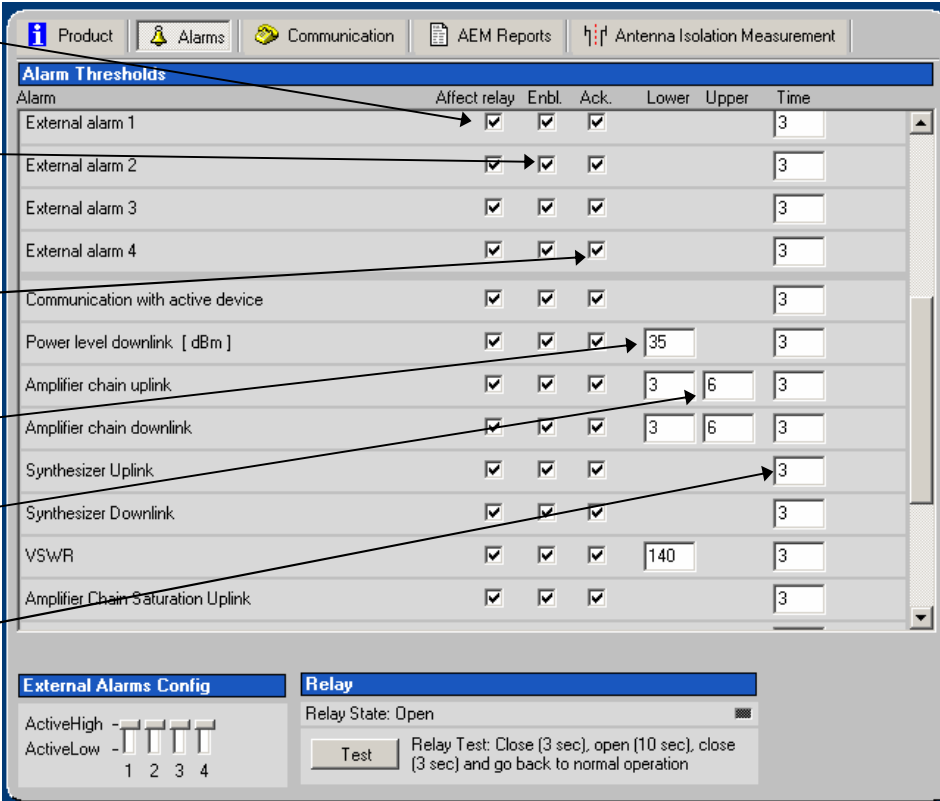

The screenshot shows the 'Alarm Thresholds' configuration window. The table below represents the data visible in the window:

Alarm	Affect relay	Enbl.	Ack.	Lower	Upper	Time
External alarm 1	<input checked="" type="checkbox"/>	<input checked="" type="checkbox"/>	<input checked="" type="checkbox"/>			3
External alarm 2	<input checked="" type="checkbox"/>	<input checked="" type="checkbox"/>	<input checked="" type="checkbox"/>			3
External alarm 3	<input checked="" type="checkbox"/>	<input checked="" type="checkbox"/>	<input checked="" type="checkbox"/>			3
External alarm 4	<input checked="" type="checkbox"/>	<input checked="" type="checkbox"/>	<input checked="" type="checkbox"/>			3
Communication with active device	<input checked="" type="checkbox"/>	<input checked="" type="checkbox"/>	<input checked="" type="checkbox"/>			3
Power level downlink [ dBm ]	<input checked="" type="checkbox"/>	<input checked="" type="checkbox"/>	<input checked="" type="checkbox"/>	35		3
Amplifier chain uplink	<input checked="" type="checkbox"/>	<input checked="" type="checkbox"/>	<input checked="" type="checkbox"/>	3	6	3
Amplifier chain downlink	<input checked="" type="checkbox"/>	<input checked="" type="checkbox"/>	<input checked="" type="checkbox"/>	3	6	3
Synthesizer Uplink	<input checked="" type="checkbox"/>	<input checked="" type="checkbox"/>	<input checked="" type="checkbox"/>			3
Synthesizer Downlink	<input checked="" type="checkbox"/>	<input checked="" type="checkbox"/>	<input checked="" type="checkbox"/>			3
VSWR	<input checked="" type="checkbox"/>	<input checked="" type="checkbox"/>	<input checked="" type="checkbox"/>	140		3
Amplifier Chain Saturation Uplink	<input checked="" type="checkbox"/>	<input checked="" type="checkbox"/>	<input checked="" type="checkbox"/>			3

Labels on the left side of the screenshot point to the following elements:

- Affect relay**: Points to the 'Affect relay' checkbox in the first row.
- Alarm transmission enabled**: Points to the 'Enbl.' checkbox in the first row.
- Requires acknowledgement**: Points to the 'Ack.' checkbox in the first row.
- Lower threshold**: Points to the 'Lower' input field in the 'Power level downlink' row.
- Upper threshold**: Points to the 'Upper' input field in the 'Amplifier chain uplink' row.
- Number of faulty measures**: Points to the 'Time' input field in the 'Amplifier chain uplink' row.

At the bottom of the window, there are two sections: 'External Alarms Config' with 'ActiveHigh' and 'ActiveLow' sliders, and 'Relay' with a 'Relay State: Open' indicator and a 'Test' button.

- ◆ Affect relay – If checked, an active alarm from the alarm source affects the relay status
  - ◆ Enabl. – If checked, the alarm is transmitted to the repeater OMC
- Note!** This only affects the transmission of the alarm. The alarm is still measured, and corresponding alarm status is still displayed in the repeater status screen and in the heartbeat reports transmitted to the repeater OMC.
- ◆ Ack. – All alarms will by default be transmitted to the repeater OMC requiring acknowledgement (the box is checked). Disabling this checkbox removes this requirement, which means that an alarm will only be transmitted once, regardless if an acknowledgement is received or not.
  - ◆ Lower – Lower threshold, not applicable for all alarm sources. Please refer to document GSM-EDGE Repeaters Command and Attribute Summary for details on the usage of thresholds for each alarm source.
  - ◆ Upper – Upper threshold, not applicable for all alarm sources. Please refer to document GSM-EDGE Repeaters Command and Attribute Summary for details on the usage of thresholds for each alarm source.
  - ◆ Time – Defines how many consecutive measurements from one alarm source that should be measured as ERROR before an alarm is triggered.

**Note!** In most cases, all default alarm configurations can be left unchanged, except the BCCH alarm configuration. Please refer to 3.2.6 BCCH Configuration for details about the BCCH alarm configuration.

### 3.4.6 Alarm Sources

#### Temperature Related Alarms

Alarm	Code	Description	Trigger
Temperature	TEM	Measures the temperature in the repeater. The temperature is located on the controller board.	Temperature too high or too low
Power Supply Temperature	PTM	Measures the temperature in the repeater's power supply	Temperature too high or too low

#### Power Related Alarms

Alarm	Code	Description	Trigger
Power Supply Level	PSL	Measures the mains power supply level. This is used to detect if the power supply in to the repeater is dropping too low or getting too high.	Level too high or too low
Power Supply 1	PW1	Measures the +28V generated by the repeater's power supply.	Level too high or too low
Power Supply 2	PW2	Measures the +15V generated by the repeater's power supply.	Level too high or too low
Power Supply 3	PW3	Measures the +6.45 V generated by the repeater's power supply	Level too high or too low
Power Supply 4	PW4	Measures the +6.45 V generated by the repeater's power supply feeding the controller	Level too high or too low
Battery for Mobile Equipment	BAT	Measures the battery charge in the repeater's backup battery	Charge drops below a defined threshold or is too high

#### User related Alarms

Alarm	Code	Description	Trigger
Valid Login to repeater	VLI	Detects a login to the repeater, either locally or via remote connection.	A successful login
User logged out from repeater	LGO	Detects a logout from the repeater.	A logout
Illegal Logins exceeded limit	ILI	Detects and counts the number of failed login attempts.  The counter is decreased by one every hour. A threshold can be set for number of allowed attempts before the login is blocked.	Threshold exceeded

## PRODUCT DESCRIPTION AND USER'S MANUAL

---

Changes made by logged in user	CLR	Detects all changes made to repeater settings by a user logged in to the repeater.	NA
--------------------------------	-----	--	----

### RF Related Alarms

Alarm	Code	Description	Trigger
Antenna Isolation Measurements	AIM	<p>Measures the antenna isolation.</p> <p>Two channels are used, one BCCH channel, and one so called Listener channel. By default, these channels are the ones configured in chain 1 and two, but can be changed using the RMC.</p> <p>The repeater can be configured to measure the antenna isolation on a certain time every day, and in case the isolation is too low, an alarm is generated.</p>	Isolation is outside defined interval
Input Overload Downlink	IOD	<p>Detects input overload on the downlink chain.</p> <p>This alarm is used to detect if there is other equipment in the frequency band causing the input of the repeater to be blocked, and hence decreasing the repeater performance. This can for example be a base station from another operator being mounted too close to the repeater's donor antenna.</p>	Overload
Input Overload Uplink	IOU	<p>Detects input overload on the uplink chain.</p> <p>This alarm is used to detect if there is other equipment within the frequency band causing the input of the repeater to be blocked, and hence decreasing the repeater's performance. This can for example be harmonics from TV-transmitters or other strong radio signals.</p>	Overload
Power Level BCCH Downlink	PDL	<p>Measures the output power of the BCCH channel in the downlink. If the BCCH drops below the configured threshold an alarm is generated.</p> <p>Reasons for the BCCH dropping might be an obstacle raised between the BTS and the repeater, or a reconfiguration of the BTS where the output power is decreased. A dropped BCCH output power from the repeater will decrease the repeater's coverage area.</p>	Output power level BCCH too low
Voltage Standing Wave Ratio Downlink	WRD	<p>Monitors the reflected power level at the server antenna port (s).</p> <p>An alarm might be caused by a broken antenna cable, or the antenna connector not being properly tightened.</p>	The difference between the transmitted and reflected power is too low

### Opto Related Alarms

Alarm	Code	Description	Trigger
Fiber Optic Receiver	FRX	Detects if the receiver is OK or not	Received signal too low
Fiber Optic Transmitter	FTX	Detects if the transmitter is OK or not	Transmitted signal too low

### Repeater Performance Related Alarms

Alarm	Code	Description	Trigger
Amplifier Chain Downlink	AMD	<p>This is a gain alarm.</p> <p>The repeater measures the input signal level in the downlink chains and compares it to expected output power with regards to attenuation in repeater. If the output power is too high or too low, something might be failing in the amplifier chain, and hence an amplifier chain alarm is triggered.</p>	Expected output power too high or too low compared to calculated output power.
Amplifier Chain Uplink	AMU	<p>This is a gain alarm.</p> <p>The repeater measures the input signal level in the uplink chains and compares it to expected output power with regards to the attenuation in repeater. If the output power is too high or too low, something might be failing in the amplifier chain, and hence an amplifier chain alarm is triggered.</p>	Expected output power too high or too low compared to calculated output power.
Amplifier Chain Saturation Downlink	ASD	<p>Measures saturation in the amplifier chain downlink.</p> <p>An amplifier chain going into saturation means that the repeater input signal level and/or gain is not set correctly. An amplifier going too deep into saturation might cause the signal quality to be decreased.</p> <p>There are four levels:</p> <ul style="list-style-type: none"> <li>◆ below optimum settings</li> <li>◆ working in the optimum range</li> <li>◆ going into saturation</li> <li>◆ well into saturation</li> </ul>	Saturation enters defined level
Amplifier Chain Saturation Uplink	ASU	<p>Measures saturation in the amplifier chain uplink. An amplifier chain going into saturation means that the repeater input signal level and/or gain is not set correctly. An amplifier going too deep into saturation might cause the signal quality to be decreased. There are four levels:</p>	Saturation enters defined level

## PRODUCT DESCRIPTION AND USER'S MANUAL

---

		<ul style="list-style-type: none"> <li>◆ below optimum settings</li> <li>◆ working in the optimum range</li> <li>◆ going into saturation</li> <li>◆ well into saturation</li> </ul>	
Synthesizer Downlink	SZD	Detects if a synthesizer in the downlink is unlocked	Synthesizer unlocked
Synthesizer Uplink	SZU	Detects if a synthesizer in the uplink is unlocked	Synthesizer unlocked
Communication Between Controller and Active Devices	COM	Detects errors in the communication between controller and active devices	Errors in the communication

### Door Alarm

Alarm	Code	Description	Trigger
Door	DOO	Checks if the repeater's door is open or closed	Door is open

### 3.4.7 External Alarms

If the option for external alarms has been included, four (4) external alarm sources can be connected to the repeater. These can be for instance fire alarms or external door sensors. These alarms operate on a voltage between 12 and 24VDC. The presence or absence of this voltage will trigger the alarm depending on how alarm thresholds have been configured. The external alarms have only two states – “ok” or “error”.

As for all alarm sources a delay can be set that defines how many seconds an alarm should be in error state before an alarm is generated

Alarm	Code	Description	Trigger
External Alarm 1	EX1	Monitors any alarm source, for example fire alarms or external door sensors connected to the external interface.	Error from alarm source
External Alarm 2	EX2	Monitors any alarm source, for example fire alarms or external door sensors connected to the external interface.	Error from alarm source
External Alarm 3	EX3	Monitors any alarm source, for example fire alarms or external door sensors connected to the external interface.	Error from alarm source
External Alarm 4	EX4	Monitors any alarm source, for example fire alarms or external door sensors connected to the external interface.	Error from alarm source

### 3.4.8 Alarm Format

Each alarm transmitted from the repeater contains a number of fields, in detail describing the event that caused the alarm. The alarm is transmitted as an ASCII text string, each field separated by a blank/white space.

Using the Avitec Element Manager to control the repeater, the alarm string is delivered to the Transceiver for further processing in the AEM system.



## PRODUCT DESCRIPTION AND USER'S MANUAL

---

When SMS is used to control the repeater, the string is sent as clear text to the alarm address (main address).

Message field	Format	Description
Repeater ID	XX-YY-ZZZZ	ID of the repeater causing the alarm. When monitoring the repeater using the AEM, this repeater ID is set by the AEM during the repeater installation phase. Using SMS, this repeater ID should be modified to uniquely identify the repeater in the network.
Message number	NNNNN	Message number from the repeater, increased for each message sent to this address
Message type	ALARM	Means that the message is an alarm or end of alarm (alarm cease)
Date	DDMMYY	Day, month and year when the alarm was detected
Time	HHMMSS	Hour, minute and second when the alarm was detected
Alarm Source	PW1, DOO...	Code for alarm source. Please refer to GSM-EDGE Repeater Command and Attribute Summary to obtain a detailed list of all available alarm sources in the repeater.
Severity	CC	Abbreviation for severity of the alarm. This severity varies between the different alarm sources. CR = critical MA = major MI = minor WA = warning CL = cleared When an and of alarm is sent, the severity is CL = cleared
Class	CC	Abbreviation for kind of alarm CO = communication alarm EN = environmental alarm QS = quality of service alarm PR = processing alarm EQ = equipment alarm
Status	C..C	Status for the Alarm Source generating the alarm. Please refer to document GSM-EDGE Repeater Command and Attribute Summary to obtain detailed information about the status. If for example Alarm Source is SZU (Synthesizer Uplink), status parameter format is described in the SZU attribute in the GSM-EDGE Repeater Command and Attribute Summary.
Additional alarm text	CC...CC	This quoted string contains additional alarm information, such as measured levels when the alarm condition was detected.

*Example:*

```
01-01-0001 00049 ALARM 251103 132137 WRD CR QS 1 "Current return loss is 9.0 dB"
```

This is an alarm message from repeater 01-01-0001, indicating that the reflected level (WRD) on the antenna port is 9.0 dB.

## 3.5 Repeater Heartbeat

On regular intervals, the repeater sends a heartbeat report to the AEM to confirm that the repeater is functioning. When monitoring the repeater using the Avitec Element Manager, the heartbeat reports play a key role. They contain the repeater configuration and are transmitted between the repeater and the AEM on regular intervals.

### 3.5.1 Heartbeat Tasks

With the heartbeat reports, a number of tasks are carried out.

#### 3.5.1.1 Ensuring Repeater to AEM Communications path

By configuring the repeater to regularly establish a connection to the AEM, the functionality of the data communications path between the repeater and the AEM is verified. This ensures that for instance the alarms will be transmitted properly.

If an expected heartbeat is not received by the AEM, an alarm is generated to the AEM operator. Reasons for a heartbeat message failing to be delivered can be:

- ◆ No power – the repeater site might experience a power failure, and the battery backing up the controller and modem is empty
- ◆ Broken donor antenna – If the repeater antennas have been tampered with, the repeater might not get adequate signal to establish a connection to the AEM
- ◆ Failing BTS – If the feeding BTS for some reason goes down, the repeater will lose its network connection, and hence fail to establish a connection to the Avitec Element Manager.

#### 3.5.1.2 AEM Database Synchronization

The Avitec Element Manager stores all repeater parameters in a database. This database is populated during the repeater integration into the AEM, when the AEM downloads all the repeater parameters. If the AEM operator wants to monitor the configuration of the repeater, the parameters can be read from the database without having to connect to the repeater.

In case of an alarm, the AEM updates the database with the status of the alarm source. In case the repeater failed to deliver the alarm to the AEM, there will be a discrepancy between the repeater configuration and the configuration in the database. Furthermore, if a technician at site makes changes to the RF-configuration of the repeater, the configuration will differ from the AEM configuration.

For this reason, each heartbeat report contains all the relevant RF-parameters and status of all the alarm sources in the repeater. This means that each heartbeat report will update the AEM with all status and RF parameters.

**Note!** Once the repeater is integrated to the Avitec Element Manager, it is recommended that all reconfigurations are made from the AEM.

**Note!** If a user logs in to the repeater making changes, as soon as the user logs out, an alarm will be transmitted to the AEM informing the operator that a change has been made. When this alarm is received, the operator can initiate repeater synchronization where all repeater parameters will be updated.

#### 3.5.1.3 Time Synchronization

Each heartbeat message transmitted to the AEM contains a time stamp of the local time inside the repeater. Upon reception in the AEM, the time stamp is compared to the Avitec Element Manager time. If the difference between the repeater and AEM time is too big, time synchronization is initiated by the AEM, adjusting the time in the repeater. In this way, we ensure that a repeater integrated to the Avitec Element Manager always contains the correct time information.

**Note!** If the time is adjusted by a user logged in to the repeater, once the user logs out, a heartbeat is sent to the AEM to ensure that the time is correctly synchronized.

### 3.5.2 Configuring the Heartbeat

The Heartbeat is configured to be transmitted on a regular interval. As soon as the report is successfully delivered, the repeater will wait the configured interval before transmitting the report again. The interval can be set from once per minute to once every 1440 minutes (24 hours). Setting the heartbeat interval to zero disables transmission of the heartbeat reports.

If the heartbeat report was not successfully transmitted, it will be retransmitted again after a configurable number of minutes. The Control Module will try a configurable number of times to transmit the report to the Avitec Element Manager / repeater OMC.

Default retransmit interval is one minute, and three retries will be made to transmit the report. In this example a heartbeat is sent every 24 hours and the number of retransmits has been set to 2 with a one minute interval.

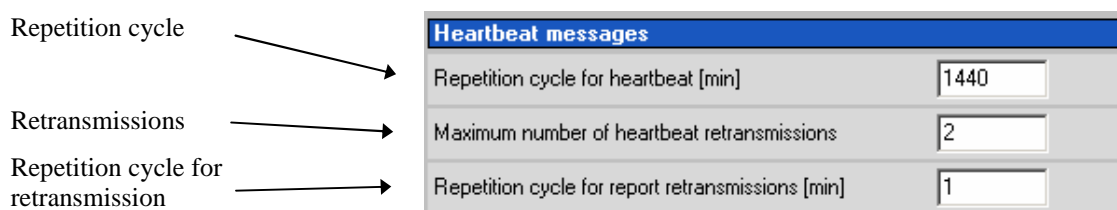

**Note!** The report retransmit interval and number of report retransmissions also applies to the traffic reports.

**Note!** When monitoring the repeater using the Avitec Element Manager, the heartbeat interval is decided by the AEM operator as a part of the repeater to AEM integration procedure.

### 3.5.3 Heartbeat Format

The heartbeat report is transmitted as an ASCII text string, with a number of fields representing the RF-configuration and status parameters, each field separated by a blank/white space.

Using the Avitec Element Manager to control the repeater, the heartbeat report is delivered to the Transceiver for further processing in the AEM system.

When SMS is used to control the repeater, the report is sent as clear text to the main address.

Since the different EDGE-GSM repeater types contain different number of configurations and alarm parameters, the formats of the heartbeats vary between repeater types. Please refer to document GSM-EDGE Repeater Command and Attribute Summary for details on the various heartbeat formats.

## 3.6 Traffic Measurement

Avitec repeaters constantly monitor the radio signal in the uplink path. By doing this, it is possible to detect how much traffic is generated from within the repeater's coverage area.

On a regular basis, a traffic report is transmitted to the Avitec Element Manager, allowing for traffic analysis to identify peak hours and hotspots in the radio network covered by the Avitec repeaters.

### 3.6.1 Traffic Measurement Procedure

The repeater software allows for real time tracing of the repeater utilization in the uplink path of the repeater.

Each chain in the repeater/LIMPA contains an RSSI (Received Signal Strength Indicator), which detects the input level. By monitoring this RSSI all the active timeslots in the uplink above a configurable threshold can be detected. A counter inside the LIMPA microcontroller counts all the detected active timeslots on a chain by chain basis.

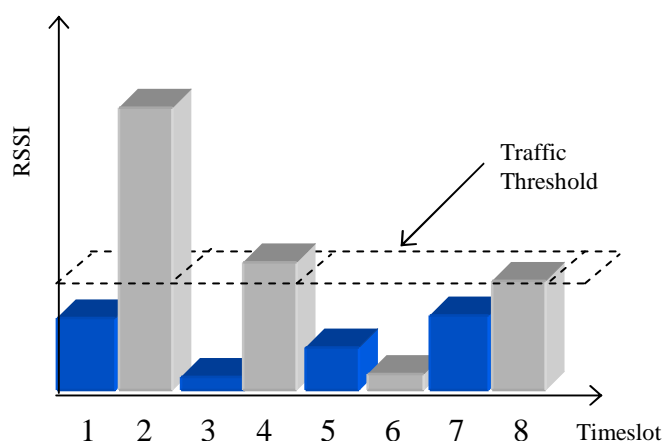

*In the example above, timeslots 2, 4 and 8 are above the configured traffic threshold*

When logged in to the repeater, real time tracking allows monitoring of how many timeslots in each GSM frame is utilized. The frame time is extracted from the BCCH signal in the downlink path.

**Note!** In order to get accurate snapshot information on how many time slots are utilized, the BCCH should always be configured for chain 1.

In case the frame time cannot correctly be extracted from the BCCH, the repeater will make an approximation. This means that the snapshot information might not be entirely accurate. However, the total number of detected timeslots does not require the BCCH to be properly configured.

Once every 15 minutes, the controller calculates the percentage of all active timeslots being above the threshold. The result is stored in a traffic log. On a configurable time of the day, the utilization for the last 24 hours is transmitted to the repeater OMC, after which the log is cleared.

The utilization is calculated as:

$$\text{Utilization} = \text{All detected timeslots} / \text{Total number of timeslots} * 100$$

### 3.6.2 Active Intervals

The repeater calculates the utilization in the uplink for each 15 minute interval (96 intervals per day). An active interval is defined as an interval where detected number of active timeslots is above a certain threshold. By default, an interval is considered active when 8 timeslots or more are detected. This feature is useful for trouble shooting purposes in low traffic areas. If no intervals have been active during the last day or so, a suspicion might be that there is an erroneous configuration or a failing server antenna.

The repeater also saves the time point for when last timeslot was detected in the uplink path of the repeater.

### 3.6.3 Viewing Traffic Reports from the RMC

Traffic reports can be monitored via the RMC.

Current 15 minute interval

Earlier intervals

Report to AEM

Real time traffic



### 3.6.4 Interpreting Traffic Data

The traffic data should not be treated as definite facts for two major reasons:

- ♦ Most GSM-EDGE networks today have DTX (Discontinuous Transmission Mode) enabled. When DTX is enabled there is only transmission from the mobile station when the user is talking. This means that even though there is a call going through the repeater there is no detectable traffic when the user is silent.
- ♦ GPRS enabled networks can use one or more timeslots, depending on network configuration, mobile type and subscriber activity.

It is not possible to make definite decisions as to how many calls are going through a repeater or if a repeater site / base station is reaching its capacity limit, but gives a very good indication about trends on the site. For a non-GPRS enabled network, reaching utilizations of up to 30% of the interval at the same time as the base station indicates 100% utilization probably means that most calls are originated from within the repeater coverage area.

### 3.6.5 Traffic Measurement Configuration

A number of different parameters are available in order to configure the behavior of the traffic measurements and traffic reports.

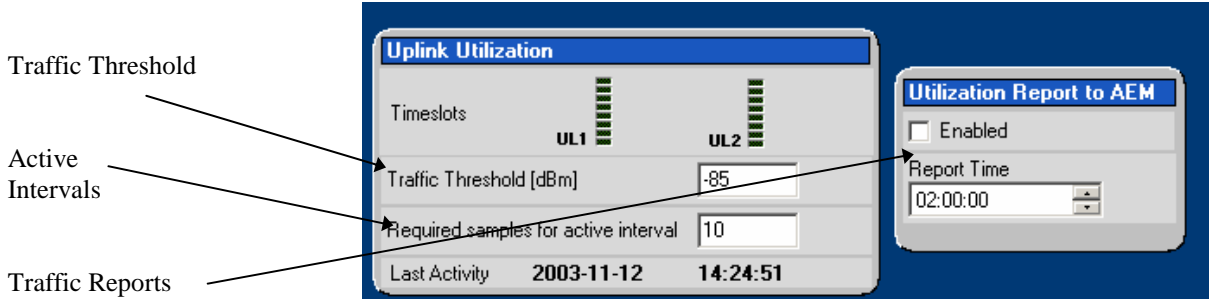

#### 3.6.5.1 Traffic Threshold

A traffic threshold can be set to define on what level measured should start. The value is set in dBm. If the traffic threshold is set to -85, any signal above -85 dBm is considered as traffic originated from within the repeater's coverage area.

#### 3.6.5.2 Active Intervals

For each 15 minute interval, all timeslots are counted. If the number of timeslots is above the active interval's threshold, the current interval is considered as an Active Interval.

This threshold is set as number of timeslots. Default value is 8 timeslots.

#### 3.6.5.3 Traffic Reports

The Traffic Report is configured to be transmitted on a fixed time point of the day. By default the repeater transmits the traffic data at 02.00.00 in the morning. A recommendation is to transmit the traffic data to the repeater OMC during low traffic hours, for example during night/early morning.

In case the traffic report was not successfully transmitted, it will be retransmitted again after a configurable number of minutes. The controller will try a configurable number of times to transmit the report to the Avitec Element Manager / repeater OMC.

Default retransmit interval is one minute, and three retries will be made to transmit the report. (Same setting as for the heartbeat)

**Note!** The report retransmit interval and number of report retransmissions also applies to the heartbeat reports.

**Note!** When monitoring the repeater using the Avitec Element Manager, the traffic report time point is decided by the AEM operator as a part of the repeater to AEM integration procedure.

**Note!** By default, in frequency translating donor repeaters, transmission of traffic data to the AEM is disabled. Since the same traffic should be transmitted through the remote and the donor unit, disabling the traffic report eliminates redundant information in the Avitec Element Manager database.

### 3.6.6 Traffic Report Format

Each traffic report transmitted from the repeater describes the repeater utilization for the last 24 hours. The traffic report is transmitted as an ASCII text string, with a number of fields describing the utilization in detail, each field separated by a blank/white space.

Using the Avitec Element Manager to control the repeater, the traffic report is delivered to the Transceiver for further processing in the AEM system.

When SMS is used to control the repeater, the string is sent as clear text to the main address.

Message field	Format	Description
Repeater ID	XX-YY-ZZZZ	ID of the repeater sending the traffic report. When monitoring the repeater using the AEM, this repeater ID is set by the AEM during the repeater installation phase. Using SMS, this repeater ID should be modified to uniquely identify the repeater in the network.
Message number	NNNNN	Message number from the repeater, increased for each message sent to this address
Message type	PERFO	Means that this is a traffic report
Date	DDMMYY	Day, month and year when message is generated
Time	HHMMSS	Hour, minute and second when message is generated
First Measure Date	DDMMYY	Date of the first traffic measurement
First Measure Time	HHMMSS	Time of the first traffic measurement
Utilization Data	M..M	M..M shows information about the 96 measured 15 minute intervals. M = '0' means a utilization of 0% to 2% M = '1' means a utilization of 2% to 4% ... M = '9' means a utilization of 18% to 20% M = 'A' means a utilization of 20% to 22% M = 'B' means a utilization of 22% to 24% ... ... M = 'T' means a utilization of 58% to 60% M = 'a' means a utilization of 60% to 62% M = 'b' means a utilization of 62% to 64% M = 't' means a utilization of 98% to 100% If no data is available, a dash ('-') is reported.

*Example:*

```
01-01-0323 00755 PERFO 270803 020001 260803 020000
00000001011212233468BCDCBCBDGKDFDEDFHJGFDCCBA9BCBDEFGEFGLKHEDEDA986867865
422321210100010000
```

This example shows a traffic report from the repeater 01-01-0323. First measurement is done at 2 AM, 26<sup>th</sup> of august 2003, and traffic report is transmitted 24 hours later.

## 3.7 Remote Communication

Avitec repeaters contain a GSM module for remote communication. There are two different ways of communication:

- ♦ Using data call / modem connection.  
**Note!** This requires the SIM-card in the GSM module to be configured with data service.
- ♦ Using SMS to configure the repeater with simple text messages.

The Avitec Element Manager always uses data call communication with the repeater, why all repeaters being controlled by the AEM must have data service enabled on the SIM card.

Configuring the repeater to send alarms and reports via SMS it is still possible to establish data calls to the repeater, as long as the SIM card is data service enabled.

The repeater contains a back-up battery, mounted in the main power supply. This battery backs up the Control Module with the GSM module. In case of a power failure, the battery contains enough energy for the repeater to dial up the repeater OMC and inform about the power supply disruption.

This section describes in detail how the remote communication works. For a step by step instruction on how to configure the remote communication, please refer to 4.4.3 Set Up Remote Access.

### 3.7.1 Modem Control

Since repeaters might be installed in remote areas and be difficult to reach, it is important that the remote communication is reliable and that a repeater can be recovered from network failures or power failures.

A number of features are implemented in order maximize the remote access availability.

#### 3.7.1.1 Tracing Modem Activity

When no one is logged in to the repeater, all activity performed between the controller and the modem is sent out via the LMT port. By connecting a cable to the LMT port and starting the RMC in Terminal Mode (or by using a terminal emulation software as described in section 1.4.1 Repeater Firmware), all controller activity can be traced. This is useful for troubleshooting the modem connection as described later.

#### 3.7.1.2 GSM Module Initialization

After a power failure, and upon user request, the controller performs a full initialization of the GSM module. This consists of three steps:

1. If the SIM-card in the GSM module has the PIN code enabled, the control module unlocks the PIN code. In case wrong PIN-code is configured, the controller will not try to unlock the SIM again until the PIN-code is changed. This avoids the SIM card being locked by a controller repeatedly trying to unlock the SIM with the wrong PIN code.
2. Once the SIM is unlocked, the controller waits for the SIM to log in to the GSM network. Depending on signal quality and network configuration this might take a while. The controller will wait a configure number of the seconds (default 50 seconds) for the GSM-module to login to the network. In case no network is found, a modem power cycle will be initiated.
3. When the module is successfully logged in to the network, the controller configures the modem with the modem initialization string as configured when setting up the remote configuration. The modem initialization string is a network dependent string. The default initialization string is suitable for most networks, but some networks might require some tweaking of this string. Refer to section 3.7.5 Troubleshooting Remote Communication, for more information.

#### 3.7.1.3 Monitoring Modem Connection

The controller constantly monitors the status of the modem connection to ensure that it is working properly, and that the modem is logged in to the GSM network.

In case the modem is not registered to the network, or the controller cannot properly communicate with the modem, a power cycling of the modem is initiated, after which the modem will reinitialized.

#### 3.7.1.4 Scheduled Modem Power Cycling

In addition to polling the modem to ensure the repeater online status, the controller can be configured to perform an automatic power cycling on a scheduled time of the day, see 4.4.3 Set Up Remote Access. Power cycling the modem ensures the latest network configuration for the GSM module, such as the HLR Update Interval etc.

**Note!** By default, the scheduled modem power cycling is disabled.

### 3.7.2 Local or Remote Access

The controller contains a connection manager that only allows for one connection at a time. This means that if a user is logged in to the repeater locally the modem will not answer incoming calls. If someone is logged



in to the repeater over the modem or the controller is busy dialing the Avitec Element Manager to deliver alarms and reports, no local login can be performed. To deliver an alarm or a report to the OMC takes from 20 to 50 seconds depending on network and modem configuration. Hence, the time the modem is occupied reporting to the AEM is very short. The controller can only configure the modem when no user is logged in to the system.

A trace of all modem initialization activities is sent out via the LMT port. This is useful when verifying and trouble shooting the remote communication.

### 3.7.3 Remote Communication using Data Call

When the repeater is configured to use data call for remote communication, the modem connection is used for delivering alarms and reports and for remote communication with the repeater.

Chapter 4.4.3 Set Up Remote Access contains step by step instruction for how to configure the repeater for communication using data call.

#### 3.7.3.1 Avitec Element Manager Addresses

The controller can be configured with two different addresses (telephone numbers) to which alarms and reports are delivered. In case the repeater cannot deliver alarms and reports to the primary address, the next call will be made to the secondary address.

A fallback functionality is available, which means that the controller falls back to the primary address after a configurable number of minutes. If this interval is set to 0, the fallback will not be performed. A user can always force the controller to fall back to the primary address.

**Note!** When the repeater is integrated to the Avitec Element Manager system, these addresses are set by the AEM, why they need not be configured during site installation.

#### 3.7.3.2 Verifying the Remote Communication

When the remote configuration has been set up and the user is logged out, the communication can be verified using the modem feature of the RMC and dialing the data number. The remote communication is verified as soon as a successful remote login to the repeater has been performed.

However, as a first step, it is recommended to verify that the modem is initialized correctly. After configuring the modem using the RMC, make sure to initiate a power cycling of the modem. This is done from the RMC menu.

Click on the drop-down menu Actions, choose Power Cycle Modem on Logout

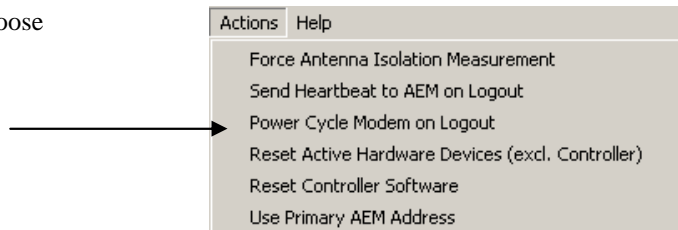

When the user logs out the controller power cycles the modem, after which the GSM modem is initialized and registered onto the network. The modem is now ready for remote access.

In case the initialization procedure reports an error, please refer to Trouble Shooting section later in this chapter.

Verify the remote communication either by having someone attempting to integrate the repeater from the Avitec Element Manager, or by dialing the repeater using the Repeater Maintenance Console.

When a successful login is made, the controller redirects the output to the modem, as in this example.

```
User logged out.
Modem powered off...
Modem powered on, waiting...
Modem reset
Disabling modem echo.
Initializing GSM module...
Registering on network.....Connected.
Initializing GSM-modem specific parameters...OK
DOME
Modem initialized
Alarm from source 88 detected. Alarmname: VLI
Device disabled - message not sent
Retransmitting alarm message.
Device disabled - message not sent
Next time to send alarm: 083315 281103
Alarm from source 89 detected. Alarmname: LGO
Device disabled - message not sent
Remote call, answering...
Redirecting output to remote login...
-
```

**Note!** It is very important to dial the data number of the SIM. In case the voice number is dialed, the call is answered, but almost immediately the call will be hung up.

### 3.7.3.3 SIM-card Using Single Numbering Scheme

If the network is configured using Single Numbering Scheme (SNS), some special considerations apply.

The Avitec repeaters are by default configured so that networks using SNS always will have calls routed to the data service in the modem. When dialing from within the network to a repeater having an SNS-configured SIM will operate normally, since the call originator informs the system that the bearer is of type DATA. However, when dialing from outside the GSM-network trying to connect to the repeater can be difficult. Depending on the interface to the roaming network or to the PSTN network if an analog modem is used, the bearer type can default to voice. If the bearer is set to voice, the data service cannot be converted to DATA, and a call setup cannot be completed.

**Note!** This is not a repeater related problem; the solution is to verify how the external network interfaces handles the VOICE vs. DATA bearer type.

## 3.7.4 Remote Communication using SMS

By configuring the repeater to communicate using SMS it is possible to receive reports and alarms, and to perform remote configuration of the repeater using simple SMS / text messages.

### 3.7.4.1 SMS Communications Overview

The SMS (Short Message Service) system in a GSM network is a point-to-point packed based messaging system, which enables mobile phones to send and receive short text messages, SMS-messages. The SMS packet can have a maximum length of 160 characters. Each message also contains information about the originator address, where the telephone numbers are referred to as MSISDN addresses.

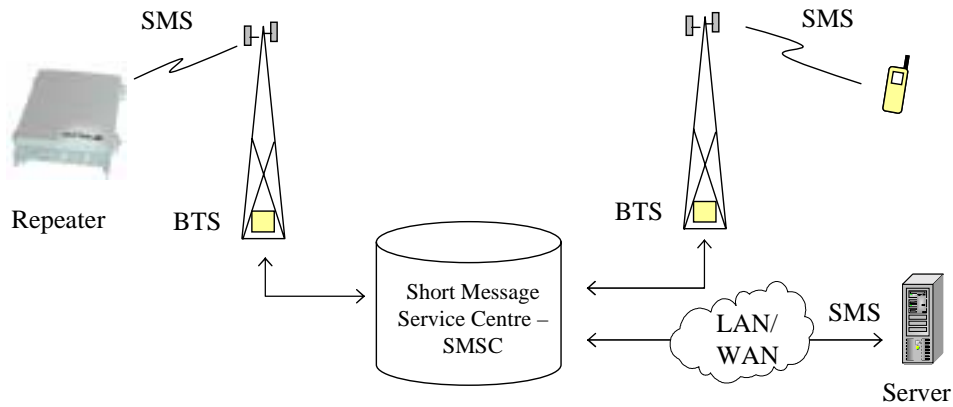

When the repeater wants to send a message to a mobile phone, the message is first sent to the Short Message Service Center (SMSC). The SMSC communicates with the network to determine where the destination mobile is located, after which the message is forwarded to the destination address as shown above. If the destination mobile phone is not within coverage or turned off, the message will be stored in the SMSC. When the mobile is turned on and logs in to the network, the SMSC will send the stored message(s) to the mobile. The SMSC center will store undelivered messages for a configurable number of hours before they are discarded (normally 3-5 days).

Optionally, a dedicated server having direct network (LAN/WAN) connection to the SMSC can be used as a repeater OMC. This means that messages coming to the SMSC from the repeater will be forwarded to the server. The server is assigned its own MSISDN within the network / SMSC, allowing for the same repeater configuration to work in this setup.

**Note!** Avitec Element Manager does not support the SMSC interface or monitoring of repeaters using SMS.

### 3.7.4.2 Repeater Access Control using SMS

When configuring the repeater for SMS communication, a repeater access list is configured, containing up to four different telephone numbers. Alarms and reports are always sent to a dedicated address, the Primary Address.

Select "Configuration" window, "Communication" page.

Choose SMS

Primary address

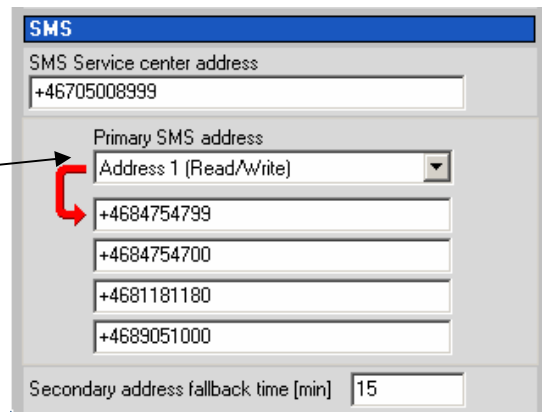

When SMS messages are sent to the repeater to read or write parameters, the repeater checks the MSISDN for the originator of the message. If the message is any of the first two telephone numbers in the access list, full access to the repeater is allowed (SET, GET and ACT messages). If the message is from any of the other numbers in the list, read-only commands (GET). Messages from any other MSISDN than those four in the list are discarded.

### 3.7.4.3 Message Formats for Repeater Configuration

Configuring the repeater is done by sending SET, GET and ACT commands in the same way as when entering commands in terminal mode. For a detailed description of all available commands, refer to document GSM- EDGE Repeaters Command and Attribute Summary.

Reading parameters will always return a reply, while setting parameters will not generate a reply message. If the syntax of the message is wrong, the repeater will reply with a message explaining the syntax error. Sending ACT (ACTion) messages will not return a reply, but might cause alarms or heartbeat reports to be sent, depending on action request.

All messages to the repeater must start with the repeater ID. In case the repeater ID is set incorrectly, the repeater replies back with an error reply containing the correct repeater ID.

All fields in the messages to and from the repeaters are separated by blanks. Maximum message length to and from the repeater is always 160 characters.

**Note!** Please refer to separate chapters on alarm format and format on traffic and heartbeat reports.

#### Format on Sending Messages

Message field	Format	Description
Repeater ID	XX-YY-ZZZZ	ID of the repeater that the message is intended for
Message number	NNNNN	Message number from the main address (any 5-digit number)
Command	GET, SET, ACT	Command type
Attribute	SSS	A three letter attribute following the GET, SET or ACT attribute
Parameters	<Text>	Optional parameters.

#### Repeater Reply Format

Message field	Format	Description
Repeater ID	XX-YY-ZZZZ	ID of the repeater sending the message
Message number	NNNNN	5-digit message number increased for every message sent from the repeater to this address.
Message Reference	MMMMM	This is a 5 digit number reference to the message number sending the message generating this reply.
Command	GET	Command type sent to the repeater, originating the message.
Attribute	SSS	Attribute sent to the repeater
Reply	<Text>	Reply message.

#### Error Reply Format

Message field	Format	Description
Repeater ID	XX-YY-ZZZZ	ID of the repeater sending the message
Message number	NNNNN	5-digit message number increased for every message sent from the repeater to this address.

Text	ERROR	Text field indicating that this is an error message.
Message Reference	MMMMM	This is a 5-digit number reference to the message number sending the message generating this reply.
Error Type	SSS	WID = Wrong repeater ID VAL = Wrong value of parameter sent COM = Command error. Unknown command or attribute.
Error Message	<Text>	A textual description of the error in the message.

*Example 1:*

## Sending

```
01-01-0001 00003 GET TAG
```

gets the site tag / name as defined during repeater installation.

*Reply:*

```
01-01-0001 00017 00003 GET TAG RFID-2339
```

indicating that the name of this site is RFID-2339.

*Example 2:*

## Sending

```
01-01-0001 00004 SET TAG RFID-2339-VALLEY
```

changes the site name to RFID-2339-VALLEY.

*Example 3:*

## Sending

```
01-01-0001 00003 SET CHA 1 125
```

generates the reply

```
01-01-0001 00018 ERROR 281103 175900 00003 VAL Error(12): Illegal channel
number, channel number is from 1 to 124.
```

### 3.7.5 Troubleshooting Remote Communication

The Avitec Repeaters are equipped with a GSM module embedded on the Control Module of the repeater. This allows for remote communication with the repeater over the GSM network. Since many networks have their own "personality", performing first time configuration of the remote communication sometimes requires tweaking of the modem parameters.

This section describes some trouble shooting techniques if configuring the repeater for remote access fails.

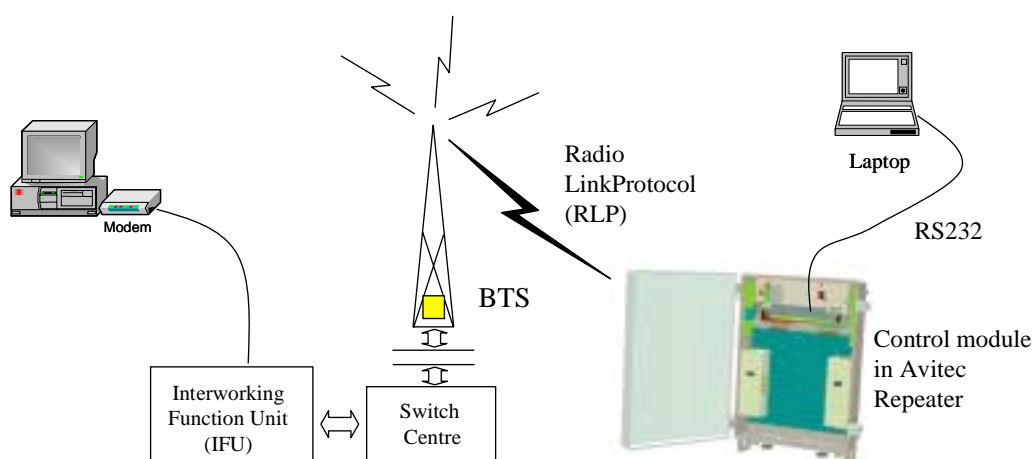

This illustration is a simplified schematic of the remote communication between a GSM module in a repeater and an analog modem. The analog modem in the computer communicates with the Interworking Function Unit (IFU), which is the GSM network analog network interface. The call is routed via the switch center over the air interface to the data call number in the SIM-card of the GSM module.

The controller is responsible for establishing connections with the Avitec Element Manager, and to answer incoming calls to the repeater.

As described in previous sections, the controller only accepts one login at a time, either via Local Maintenance port (LMT) or modem connection. Hence, when verifying the remote access of the repeater, it is important to log out from the repeater locally before trying to access the repeater remotely.

### 3.7.5.1 Modem Initialization Errors

As described in section 3.7.3.2 Verifying the Remote Communication, it is recommended to switch over to terminal mode after doing the modem configuration, to log out from the repeater and observe the output from the controller.

A number of different failure messages can be identified.

In this example the controller fails to initialize the modem. The most common reason for this failure is that the SIM-card is not inserted correctly, or that the SIM is broken.

```
User logged out.
Modem powered off...
Modem powered on, waiting...
Modem reset
Disabling modem echo.
Initializing GSM module...
Cannot initialize modem!
Checking modem connection...Modem not initialized!
Disabling modem echo.
Initializing GSM module...
Cannot initialize modem!
ERROR
Switching modem off-line...
```

## PRODUCT DESCRIPTION AND USER'S MANUAL

---

As stated in this screen dump, this failure is caused by the wrong PIN-code being configured. No more attempts will be made to unlock the PIN-code until the code is reconfigured. Try configuring the correct PIN-code by logging in to the RMC again. Optionally, disable the PIN-code request on the SIM. This is easiest configured by disabling the PIN-code request of the SIM using a normal GSM phone.

```
User logged out.
Modem powered off...
Modem powered on, waiting...
Modem reset
Disabling modem echo.
Initializing GSM module...
Cannot initialize modem, wrong PIN code configured.
Checking modem connection...Modem not initialized!
Disabling modem echo.
Initializing GSM module...
Cannot initialize modem, wrong PIN code configured.
ERROR
Switching modem off-line..._
```

This error is reported when the wrong modem initialization string is configured. Login to the RMC and verify that the correct modem initialization string is set. For details on the different modem initialization strings, please refer to the document GSM Module - AT Command Reference.

```
User logged out.
Modem powered off...
Modem powered on, waiting...
Modem reset
Disabling modem echo.
Initializing GSM module...
Registering on network.....Connected.
Initializing GSM-modem specific parameters...Cannot initialize modem!
Retransmitting alarm message.
Device disabled - message not sent
Alarm from source 88 detected. Alarmname: VLI
Device disabled - message not sent
Retransmitting alarm message.
Device disabled - message not sent
Next time to send alarm: _
```

The modem failing to register on the network mainly depends on that the GSM signal detected by the modem is too low.

```
User logged out.
Modem powered off...
Modem powered on, waiting...
Modem reset
Disabling modem echo.
Initializing GSM module...
Registering on network.....
.....No network found!
Cannot initialize modem!
Checking modem connection...Modem not initialized!
Disabling modem echo.
Initializing GSM module...
Registering on network..._
```

The signal level might be too low because of some different reasons:

1. The GSM network is temporarily out of service.
2. Signal from the BTS is too low (misaimed antennas or broken feeder cables).
3. The modem cable between the Donor FDM and the modem has been tampered with.

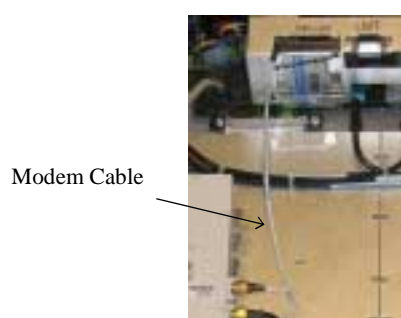

#### 4. Modem broken.

The modem normally needs a signal level of -105 dBm or better to successfully log in to the network.

Please refer to 3.7.5.4 Common Problems, on how to read the modem signal level when logged in locally to the repeater.

#### 3.7.5.2 Direct Modem Access

To allow for advanced trouble shooting of the communications, it is possible to access the modem directly via the Control Module from a laptop.

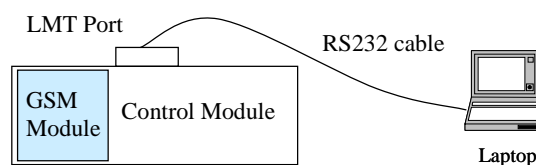

Log in to the repeater as usual, either with RMC, or with a terminal emulation program, such as HyperTerminal™. If using RMC. When the login is completed, select Terminal Mode, this will give access to the repeater command prompt in the same way as with HyperTerminal.

When the repeater prompt is accessible, type in the command

```
ACCESS MODEM
```

press <Enter>.

When typing ACCESS MODEM, the controller will send all the characters typed directly out the modem port. All characters replied back from the modem will directly go out the LMT port back to the computer.

To abort an ACCESS MODEM session, press <Ctrl-C> or press three '-' in a row (all three within one second) to come back to the repeater command prompt.

**Note!** When accessing the modem port the modem might be configured with “echo off”, meaning that the characters entered will not be echoed back to the screen. In order to enable “echo”, press Enter.

After that, type

```
ATE1
```

(invisible), followed by Enter. The modem should then reply with

```
OK
```

indicating that the echo is enabled. All characters entered will now be echoed back to the terminal program.

#### 3.7.5.3 Manually answering incoming calls

It is possible to manually answer incoming calls without involving the repeater software at all, to verify that the remote access and the network itself works as intended. In order to verify the remote communication, make sure to have someone stand by to dial up the repeater with a terminal emulation program, for example HyperTerminal™.

Go in to Direct Modem Access as described earlier. When in direct access mode, ask the person standing by to dial up the repeater.

As soon as a call is received, the text

```
RING
```

will repeatedly be displayed on the screen.



## PRODUCT DESCRIPTION AND USER'S MANUAL

---

Type the modem command

ATA

press enter. This will inform the modem to answer (ATtention Answer).

When the connection is established, a connect message will be displayed including the connection speed. Sometimes the information comes together with some miscellaneous information, such as error correction protocols etc.

**Note!** Make sure the remote peer dials the Data Call number

As seen in the example, if the voice number is dialed instead of the data number, or if the modem contains an illegal modem initialization string, the message

OK

or

NO CARRIER

will be displayed almost immediately.

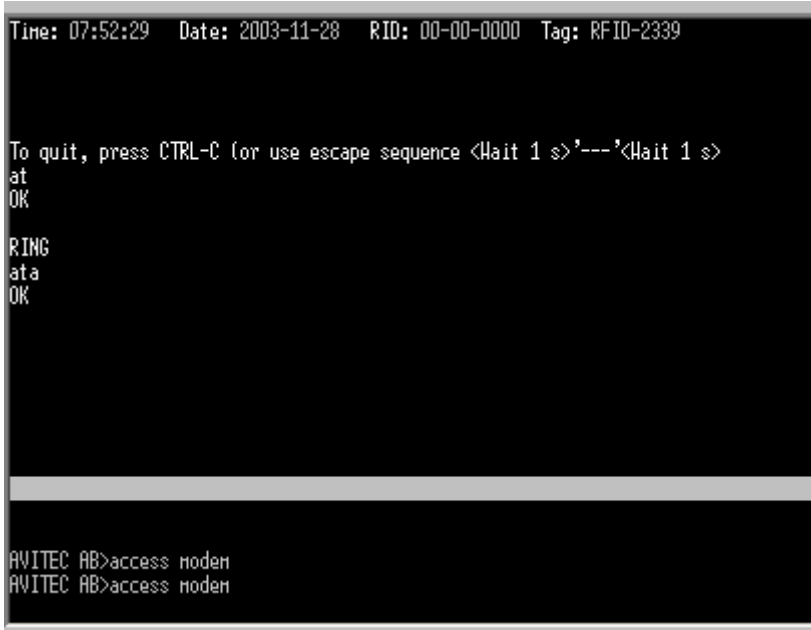

```

Time: 07:52:29 Date: 2003-11-28 RID: 00-00-0000 Tag: RFID-2339

To quit, press CTRL-C (or use escape sequence <Hait 1 s>^---^<Hait 1 s>
at
OK

RING
ata
OK

AVITEC AB>access modem
AVITEC AB>access modem
  
```

Try to change the modem initialization string. The modem initialization string mainly used to configure the remote communication is AT+CBST.

Successful modem initialization strings used by Avitec includes (most common first):

```

AT+CBST=7,0,1
AT+CBST=0,0,1
AT+CBST=7,0,3
AT+CBST=7,0,1
  
```

Once the modem initialization string is entered, try again to dial up the repeater. For details on the different modem initialization strings, please refer to the document GSM Module - AT command reference.

If the setup is successful, the connect message will be brought up;

```
CONNECT 9600
```

This means that an online connection is established to the remote peer. From now on, all characters typed on the keyboard will end up on the remote peer's screen. Similarly, all characters typed by the remote peer will be displayed on the screen.

In the example, the incoming call was successfully answered, and the remote user entered the text message.

```
Time: 08:03:49 Date: 2003-11-28 RID: 00-00-0000 Tag: RFID-2339

To quit, press CTRL-C (or use escape sequence <Hait 1 s>'---'<Hait 1 s>
at
OK

RING
ata
CONNECT 9600
This communication seems to work fine!!!

AVITEC AB>
AVITEC AB>
AVITEC AB>
AVITEC AB>access modem
```

In order to come back to modem command mode, press +++ (three pluses) rapidly (within one second).

Receiving

OK

means that the modem is back in command mode.

Typing

ATH

followed by <Enter> terminates the connection to the remote peer. The message

NO CARRIER

will be displayed.

#### 3.7.5.4 Common Problems

##### Problem

When enabling the remote access for the repeater, the modem fails to log in to the network.

##### Solution

Signal strength from the donor site is too low. The signal strength can be read directly from the modem. Go in to Direct Modem Access as described earlier. Use the command AT+CSQ (documented below) to read out the signal strength.

In order to have good signal quality, Avitec recommends that the signal strength should be better than -95 dBm. If signal strength is lower, try to adjust the antennas to get a better signal strength from the donor.

## **6.1 Signal Quality +CSQ**

### **6.1.1 Description :**

This command is used to know the *received signal strength indication* (<rssI>) and the *channel bit error rate* (<ber>) with or without any SIM card inserted.

### **6.1.2 Syntax :**

Command syntax : AT+CSQ

Command	Possible responses
AT+CSQ	+CSQ: <rssI>,<ber> OK <i>Note : &lt;rssI&gt; and &lt;ber&gt; as defined below</i>

### **6.1.3 Defined values :**

<rssI> :	0	: -113 dBm or less
	1	: -111 dBm
	2...30	: -109 to -53 dBm
	31	: -51dBm or greater
	99	: not known or not detectable
<ber> :	0...7	: as RXQUAL values in the table GSM 05.08
	99	: not known or not detectable

*Documentation of +CSQ command from modem manual*

In the example the reply to AT+CSQ is 0,7 meaning 7\*2 dB above -113 dBm; the modem detects a signal level of -99 dBm.

```

Time: 07:57:46 Date: 2003-11-28 RID: 00-00-0000 Tag: RFID-2339

To quit, press CTRL-C (or use escape sequence <Hait 1 s>'---'<Hait 1 s>
at+creg?
+CREG: 0,1

OK
at+csq
+CSQ: 7,0

OK

AVITEC AB>
AVITEC AB>
AVITEC AB>
AVITEC AB>access modem

```

## Problem 1

Repeater is configured properly, and answers the incoming call, but when trying to dial the repeater using an analogue mode, no modem handshaking is heard from the dialing modem.

## Problem 2

When dialing the repeater, the repeater answers the incoming call, but no connection is established, and after a while the repeater disconnects the call.

### Solution to the above problems

The most common cause is that the number called is the voice number of the SIM, not the data number. Therefore, make sure to dial the data number.

If data call is used, the problem probably is an illegal modem initialization string.

In order to change the modem string, go to the repeater command prompt. Try changing the modem initialization string and log out to let the controller reinitialize the modem.

If problem remains, try a few different modem initialization strings. Avitec have been successful with the following modem initialization strings:

```
AT+CBST=7,0,1
AT+CBST=0,0,1
AT+CBST=7,0,3
AT+CBST=7,0,1
```

Please refer to the modem manual for detailed description of the modem initialization strings.

## Problem

It is possible to call the repeater from another GSM mobile, but not from an analog modem.

### Solution

This problem is most likely related to the modem configuration and/or the configuration of the IFU unit. Try to decrease the communications speed and make sure that the modem error correction is supported by the IFU. Verify the IFU configuration to see if there are any known problems with the modem connections.

## Problem

When dialing the repeater, or when the repeater is dialing the Element Manager, the connection is terminated before the handshaking is completed.

### Solution

When a repeater is answering an incoming modem call, or calling up the OMC to deliver an alarm or a report, the repeater will wait a configurable number of seconds for the call to be established. If no communication is established within this time, the call will be hung up. If this interval is set too low, the handshaking is terminated too fast. In the RMC, verify the Modem Connect Time to see that it is set to at least 30 seconds.

## 3.8 Upgrading Repeater Firmware

The software installed in the repeater is called firmware. Using the RMC it is possible to see what firmware is installed, install upgrades etc

The firmware can be upgraded in the field while the repeater is operational.

The RMC is used to upload software to the controller. Since the controller contains two separate software banks, software can be downloaded to one bank while executing from the other. Once software is successfully uploaded, the new software is executed.

All repeater configurations remain unchanged when upgrading the software to a new version.

Firmware Control via RMC	
View the currently installed firmware	<ol style="list-style-type: none"> <li>1. Open the <i>Firmware upload</i> view in RMC.</li> </ol> <p>In the box labeled <i>Installed Firmware</i> information about the currently installed firmware is displayed.</p>
Upload new firmware	<ol style="list-style-type: none"> <li>1. Open the <i>Firmware upload</i> view in RMC. In the box labeled <i>Firmware Location</i> select the directory where your firmware files (ARF files) are located.</li> <li>2. Select the firmware to upload from the firmware list, labeled <i>Select new firmware to upload</i>. For each firmware available, there is information about version and compatibility with the repeater you are currently connected to. Below this list there is a box with detailed information about the selected firmware.</li> <li>3. Click <i>Start Upload</i>. During upload a status screen displays upload progress information while you wait. The upload takes about 10 minutes with a local connection and 15 minutes over the GSM network.</li> <li>4. Upload completed.</li> <li>5. The user is logged out and the new firmware is initiated.</li> </ol>

## 4 Installation

### 4.1 Prepare the Site

- 4.1.1 Site Selection
- 4.1.2 Antennas
- 4.1.3 Antenna Isolation Test
- 4.1.4 Site Installation Advice
- 4.1.5 Link Budget
- 4.1.6 Engineering Considerations

### 4.2 Install Repeater

- 4.2.1 Unpack the Repeater
- 4.2.2 Mount the Repeater
- 4.2.3 Ensure Proper Grounding
- 4.2.4 Ensure Good EMV Protection
- 4.2.5 Attach Antenna Cables
- 4.2.6 Supply Power to the Repeater
- 4.2.7 Mount the Coupler
- 4.2.8 Connect External Alarms

### 4.3 Start up Repeater

### 4.4 Configure Repeater

- 4.4.1 Set up RF Configuration
- 4.4.2 Set Repeater Name
- 4.4.3 Set up Remote Access
- 4.4.4 Alarm Configuration
- 4.4.5 Heartbeat Configuration
- 4.4.6 AEM Report Configuration

### 4.5 Installation Checklists

## 4.1 Prepare the Site

### 4.1.1 Site Selection

Site selection is one of the most critical decisions affecting the overall performance of the system.

#### Repeater locations

These are examples of common repeater locations.

- ♦ roofs of buildings adjacent to the affected area with the antennas mounted to the penthouse or building sides
- ♦ top of a hill that is obstructing the donor site's coverage, with the antennas mounted on poles at ground level
- ♦ a water tower with antennas mounted at the top
- ♦ an existing utility pole with equipment and antennas mounted below any existing power lines
- ♦ a newly installed pole or tower

#### Important Issues

There are a few important considerations to be made while choosing the best possible site for a repeater:

- ♦ Ensure access to commercial power (sun-panels is an option)
- ♦ Ensure adequate signal strength. For example: to obtain the maximum output, e.g. +37 dBm, from a channel selective repeater an input signal of approximately -53 dBm is needed into the repeater<sup>3</sup>. To obtain the maximum output from a Frequency Translating Repeater's remote site, e.g. +40dBm, an input signal of -65 dBm is needed.
- ♦ A conventional channel selective repeater must be located where the BTS signal strength is great enough to be recognized by the system. It should also be located no more than 15 km from the donor site and 5 km from the furthest area to be served.
- ♦ Ensure line of sight (LOS) between the BTS antenna and the repeater's donor antenna for channel selective repeaters, and between the link antennas for frequency translating repeaters. If the signal strength is adequate, LOS may in some cases not be necessary.

### 4.1.2 Antennas

Select antennas for the system with the proper directivity and high front-to-interference ratio in order to optimize repeater coverage and system noise performance.

Ensure adequate antenna insulation for the chosen repeater type.

Link antennas typically have a narrow horizontal and vertical beam width (less than 35 degrees) and high gain (15 – 25 dBi). The narrow horizontal beam width will keep interference from the repeater link channel to a minimum. Parabolic disc antennas which offer beam widths of <10 degrees are ideal for both donor and remote link antennas.

Server antennas are determined by the type of area to be covered. For a conventional repeater it can be any standard GSM base station antenna that has a good front to back ratio ( $\geq 25$  dB) and between 30 and 120 degrees horizontal beam width, depending on the desired coverage area. For a frequency translating antenna it may be an omni antenna.

Use compass or planning tool to get the exact direction and tilt of the antenna

---

<sup>3</sup> The input signal to the antenna needs to be -71 dBm if the antenna gain is 18dBi

## Antenna Types

For server antenna purposes panel antennas are suitable for Channel Selective Repeaters and omni antennas or directional antennas for Frequency Translating Repeaters.

Link antennas and pick-up antennas are often narrow beam panel antennas with high gain for Channel Selective repeaters and narrow beam antennas with gain depending on distance for Frequency Translating Repeaters

## Antenna Direction

Direct repeater coverage away from the donor cell to minimize RF signal coverage overlap. If the BTS has different sectors always choose to use the carriers used in the sector facing away from the remote site in order to avoid inter symbol interference (ISI).

### 4.1.3 Antenna Isolation

The antenna isolation is the difference between the output signal on the server antenna and the signal leaking into the donor or link antenna.

At a conventional installation with a channel selective repeater the antenna isolation needs to be large enough not to cause any signal distortion. For EDGE-signals (8-PSK) as much as 25 dB of margin (antenna isolation – repeater gain) may be required to maintain signal quality. At the remote site of a frequency translating repeater installation the antenna isolation needs to be approximately 75dB.

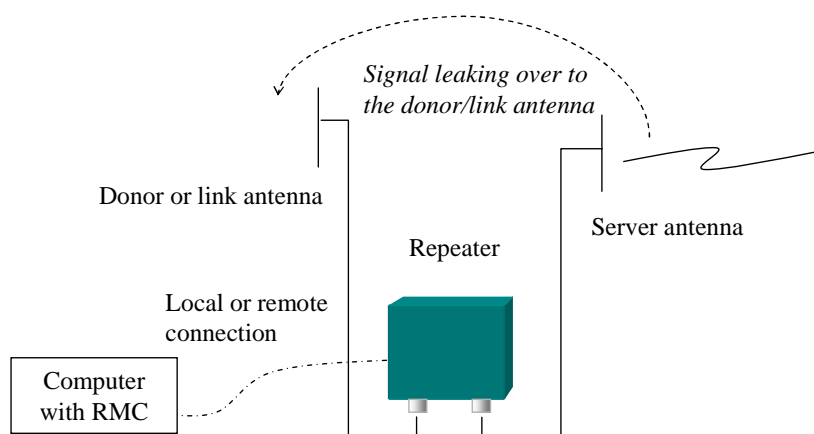

The antenna isolation can be measured through the use of a function in the RMC. The measurement can be made at the time the repeater is configured as well as regularly when the repeater is up and running. The measurement can be made when the repeater is operational.

**Note!** The measurement only takes a few seconds, but if the repeater is operational at the time of the measurement there is a risk of loosing calls during the time the parameters are changed.



PRODUCT DESCRIPTION AND USER'S MANUAL

Prepare for the measurement

Ensure that the BCCH is in chain 1.

Use a “silent” channel in chain 2. This channel will be used for detecting the leaking signal and needs to be free of traffic.

Initiate a single measurement

Select RMC “Console” mode and the “RF/status” window

Use the Actions drop down menu and select “Force Antenna Isolation Measurement”

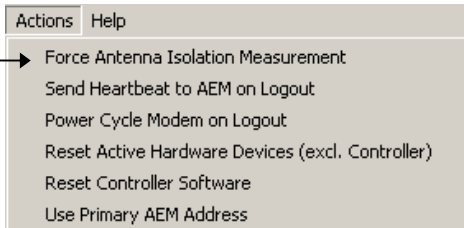

Click on  to monitor the result

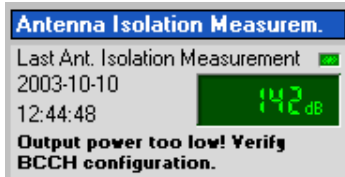

Initiate regular measurements

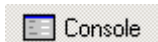

Select RMC “Console” mode



Select “Configuration” window



Select “Antenna Isolation Measurement” page

Tick “Enable Daily Antenna Measurement”. Set the time point for the measurement and define the channels to be used. The default value is the BCCH.

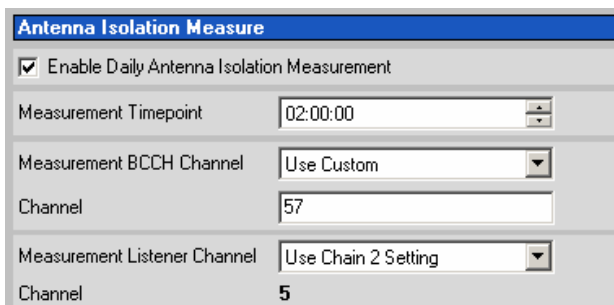

#### 4.1.3.1 Alternative method for antenna isolation measurement

The antenna isolation can also be measured by use of a signal generator and a spectrum analyzer. Use a signal generator to generate a carrier wave signal on the server antenna, and a spectrum analyzer to measure the signal leaking over to the donor antenna. The repeater does not need to be connected.

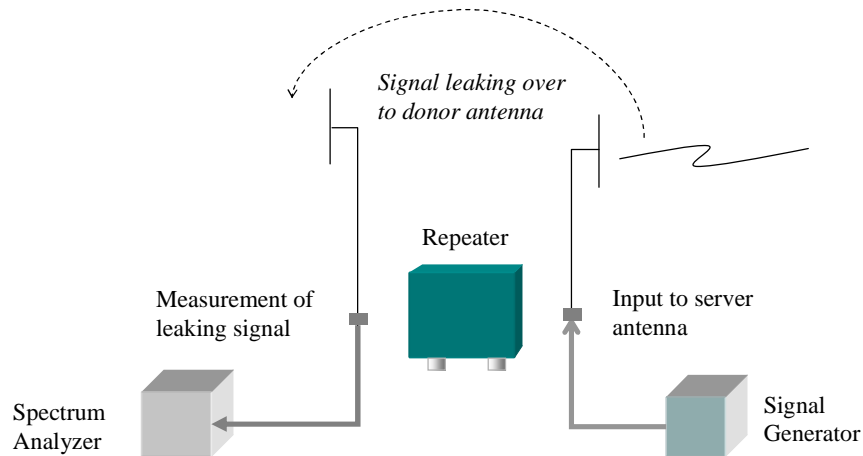

## 4.1.4 Site Installation Advice

### 4.1.4.1 Channel Selective Repeaters

In a channel selective repeater there are two antennas – one donor antenna to pick up the signal from the BTS and one server antenna to serve the coverage area.

An input signal to the repeater of more than -49 dBm must be present to obtain +37 dBm output. This example illustrates the various signal levels and antenna gains needed to form a properly functioning repeater system.

Received signal level	-72 dBm
Donor antenna (4 ft dish)	+25 dBi
<u>Cable loss (100 ft of 7/8 inch)</u>	<u>-2 dB</u>
Input to repeater	-49 dBm
<u>Gain of repeater (example)</u>	<u>+86 dB</u>
Output from repeater	+37 dBm
Cable loss (100 ft of 7/8 inch)	-2 dB
<u>Server antenna gain</u>	<u>+13 dBi</u>
Repeater ERP	+48 dBm

The donor antenna faces the BTS. Free line of sight is desirable but not necessary if the signal strength at the exact location of the antenna is strong enough.

The server antenna may be mounted above or below the donor antenna depending on the site conditions. Important is the vertical separation needed to achieve adequate isolation between antennas. The isolation has to be at least 10-25 dB higher than the repeater gain (the higher number for EDGE). This may well be in the region of 20 meters or more. Other alternatives are metal screening with wire mesh or horizontal antenna separation.

A high gain antenna will help in minimizing the overall path loss to achieve the desired output power. Donor antenna gains are typically 20 to 25 dBi, while server antennas are often 10 to 15 dBi. The server antenna normally has a horizontal beam of 60° to 120°. Donor antennas should have a horizontal and vertical beam width of less than 30° to correctly select the donor base station (instead of other nearby base stations).

This table can be used as a guideline for antenna separation. Antennas are assumed to be highly directional and pointed in the opposite direction.

Vertical Antenna separation		Horizontal Antenna Separation	
Separation (m)	Isolation (dB)	Separation (m)	Isolation (dB)
5	75	5	45.5
10	87.1	10	51,7
20	99,1	50	65,5
30	106.2	100	71.5
40	111,2	150	75,1
50	115	250	77,6

*The table demonstrates that vertical separation is much more effective.*

## PRODUCT DESCRIPTION AND USER'S MANUAL

---

The physical separation between the donor and server antennas has been calculated using the following formulas.

Vertical Separation:  $I \text{ (dB)} = 28 + 40 \log (D/\lambda)$

Horizontal Separation:  $I \text{ (dB)} = 22 + 20 \log (D/\lambda) - (G_d - G_s)$

I	=	Isolation
D	=	Distance between donor and server antennas (m)
$\lambda$	=	Wavelength (m)
G <sub>d</sub>	=	Gain of donor antenna facing server antenna (dB)
G <sub>s</sub>	=	Gain of server antenna facing donor antenna (dB)

### Site Installation Channel Selective Repeater

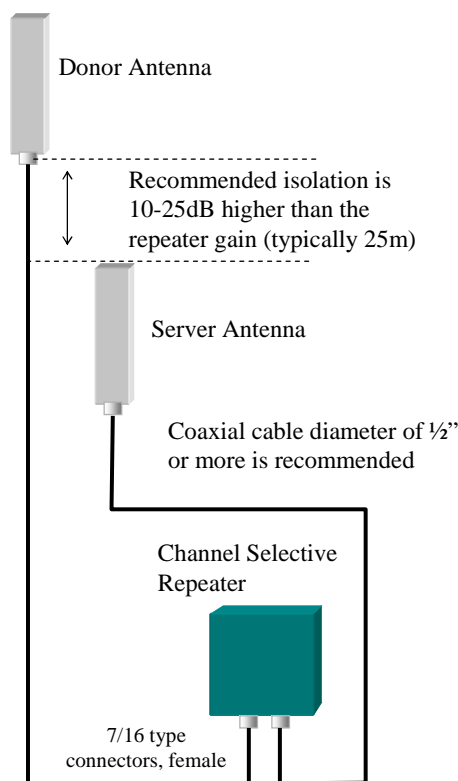

#### *Site installation for channel selective repeaters*

#### 4.1.4.2 Frequency Translating Repeaters

A Frequency Translating Repeater consists of two parts – a donor unit and a remote unit. The donor unit is installed at the base station site and connected to the base station through a 30 dB RF coupler.

A separation of at least 2 carrier bands (600 kHz) is necessary between the link frequencies and the Broadcast Carrier Frequencies. In the illustration below the link carriers are F6 and F7 and the Broadcast Carrier Frequencies are F1 and F2 which gives more separation than is needed.

**PRODUCT DESCRIPTION AND USER'S MANUAL**

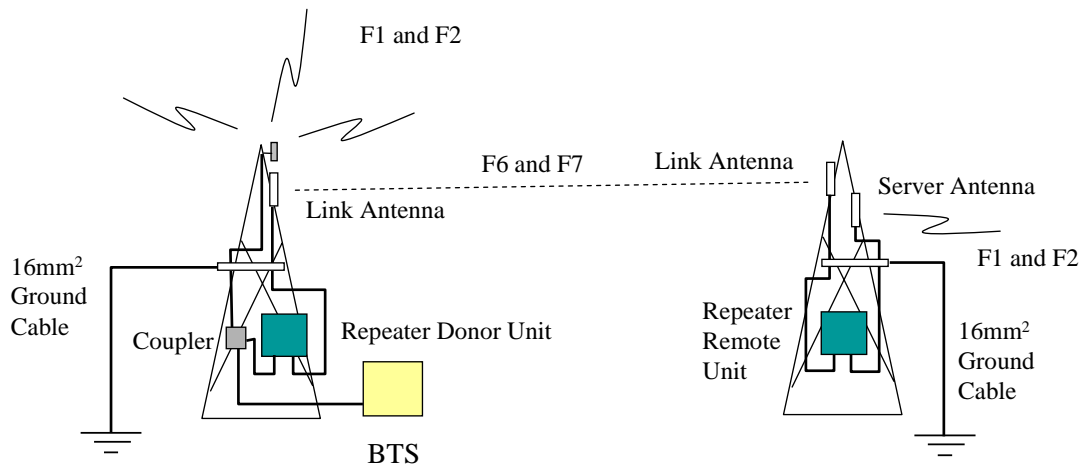

It is important to remember that a whole sector must be used when installing a Frequency Translating Repeater. The base station sector using F1 and F2 is transmitted to the repeater. The base station sector used must have the same number of carriers as the repeater.

At the remote site an input signal greater than -75dBm is desired. An input of -65 dBm is necessary to deliver an output of +40dBm.

This example illustrates the signal levels and antenna gains needed to form a properly functioning repeater system.

Received signal level	-87 dBm
Donor antenna (4 ft dish)	+25 dBi
<u>Cable loss (100 ft of 7/8 inch)</u>	<u>-2 dB</u>
Input to repeater	-64 dBm
<u>Gain of repeater (example)</u>	<u>+105 dB</u>
Output from repeater	+41 dBm
Cable loss (100 ft of 7/8 inch)	-2 dB
<u>Server antenna gain</u>	<u>+13 dBi</u>
Repeater ERP	+52 dBm

The isolation between antennas at the remote site seldom needs to be more than 75dB. This value can be achieved with a limited antenna displacement, often as low as 3 meters. The relatively modest isolation requirement allows the use of omni-directional antennas for coverage.

A high gain antenna will help in minimizing the overall path loss to achieve the desired output power. Donor antenna gains are typically 20 to 25 dBi, while server antennas are often 10 to 15 dBi. The coverage antenna normally has a horizontal beam of 60° to 120°. Donor antennas should have a horizontal and vertical beam width of less than 30° to correctly select the donor base station (instead of other nearby base stations).

This table can be used as a guideline for antenna separation. Antennas are assumed to be highly directional and pointed in the opposite direction.

Vertical Antenna separation		Horizontal Antenna Separation	
Separation (m)	Isolation (dB)	Separation (m)	Isolation (dB)
5	75	5	45.5

**PRODUCT DESCRIPTION AND USER'S MANUAL**

---

10	87,1	10	51,7
20	99,1	50	65,5
30	106,2	100	71,5
40	111,2	150	75,1
50	115	250	77,6

*The table demonstrates that vertical separation is much more effective*

The physical separation between the donor and server antennas has been calculated using the following formulas.

Vertical Separation:  $I \text{ (dB)} = 28 + 40 \log (D/\lambda)$

Horizontal Separation:  $I \text{ (dB)} = 22 + 20 \log (D/\lambda) - (G_d - G_s)$

I = Isolation

D = Distance between donor and server antennas (m)

$\lambda$  = Wavelength (m)

G<sub>d</sub> = Gain of donor antenna facing server antenna (dB)

G<sub>s</sub> = Gain of server antenna facing donor antenna (dB)

Site Installation Frequency Translating Repeater

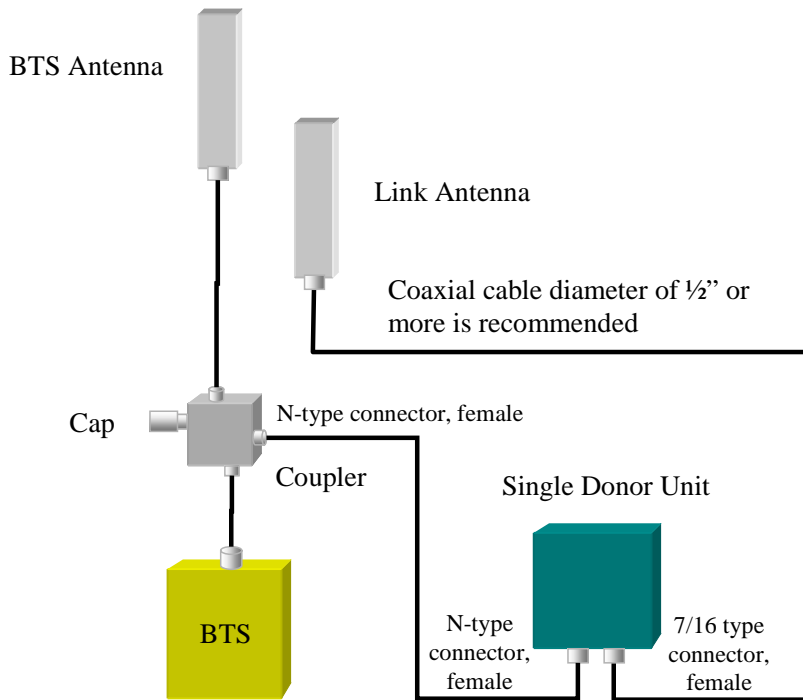

Site Installation for Frequency or Band Translating Repeater – Single Donor Unit

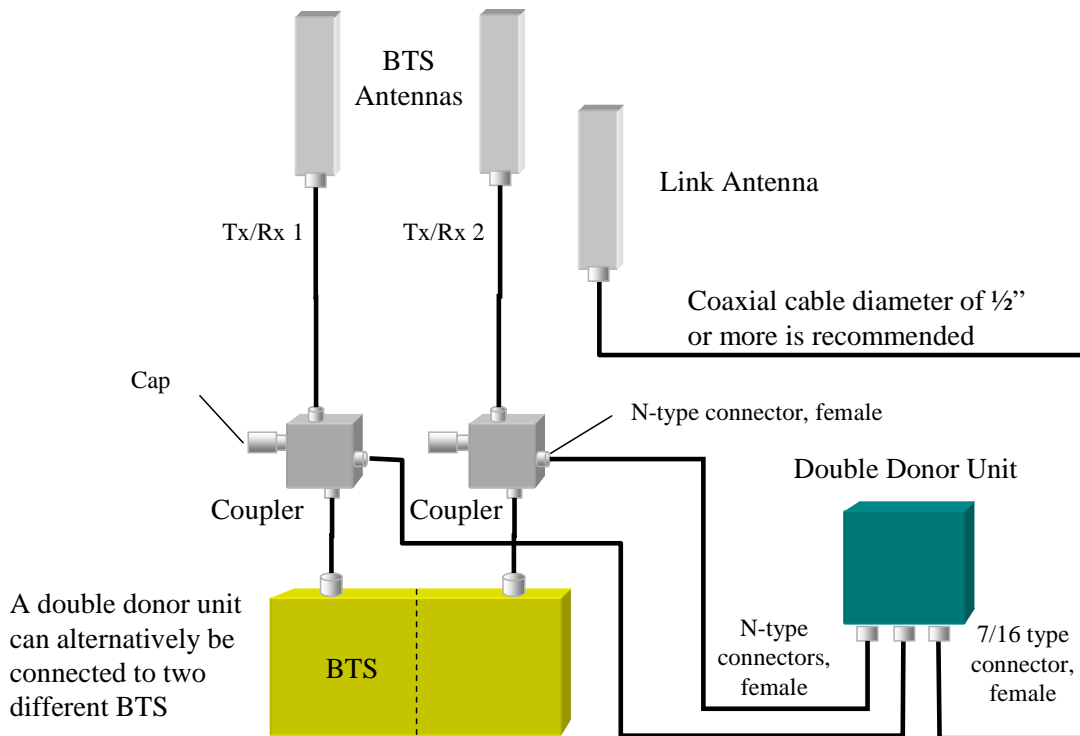

Site Installation for Frequency Translating Repeater – Double Donor Unit

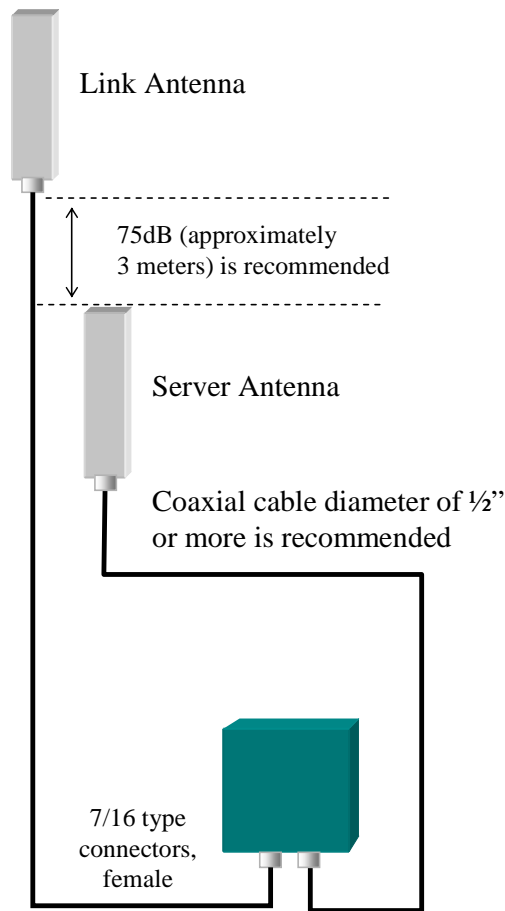

*Site Installation for Frequency Translating Repeater – Internal Combiner Unit (IR)*

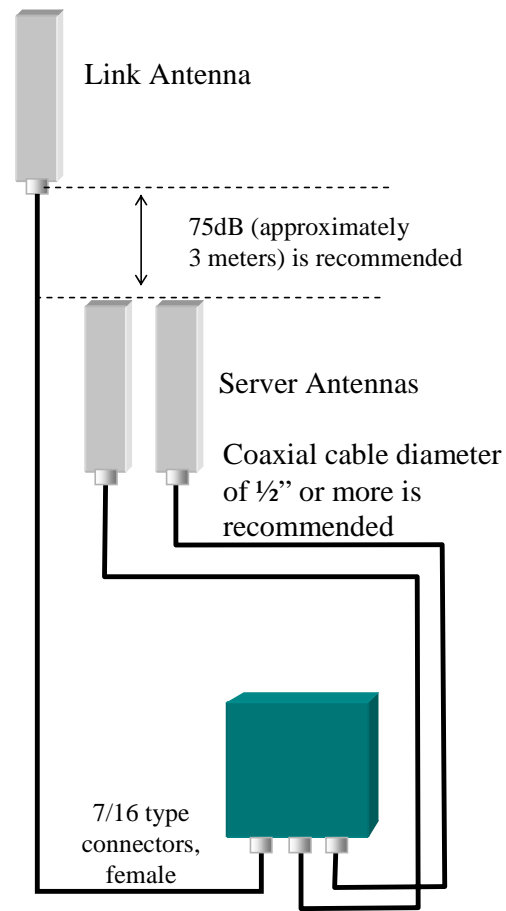

*Site Installation for Frequency Translating Repeater – External Combiner Unit (ER)*

#### 4.1.4.3 Band Translating Repeaters

A Band Translating Repeater is identical with a frequency translating repeater; the only difference is that the link is on another band than the broadcast frequency.

By using another band for the link the isolation between antennas at the remote site becomes very low. It is for most applications possible to use the same antenna for both the link and the service area.



#### 4.1.4.4 Fiber Fed Repeaters

A fiber fed repeater needs to be fed from a Hub or an Opto Box which translates the RF signal to an optical signal.

The server antenna is often replaced by a leaky cable.

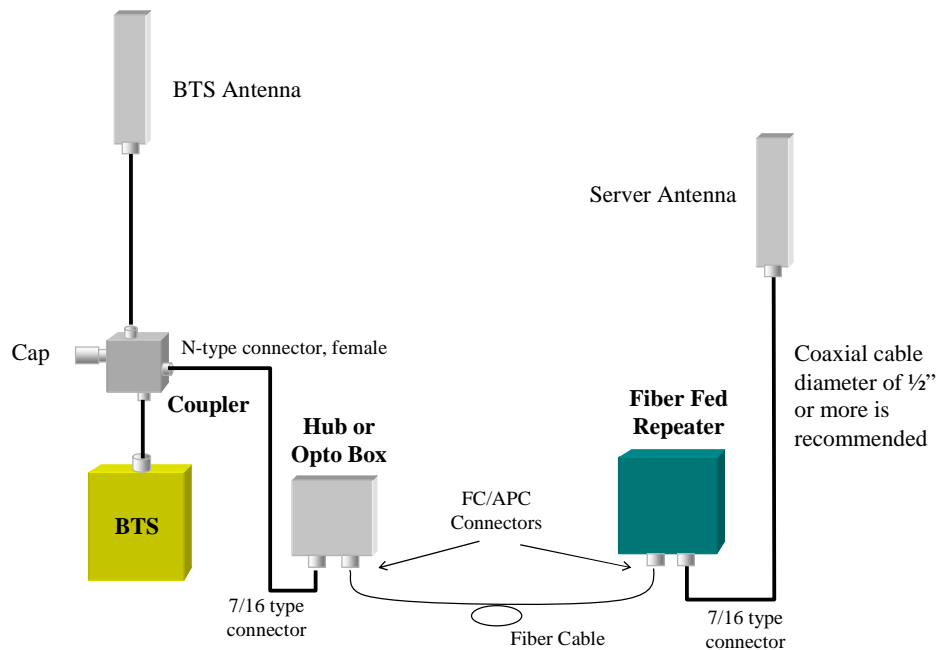

*Site installation for fiber fed repeaters*

### 4.1.5 Link Budget

It is important to make a link budget before the installation is completed. This budget will give the necessary input for tuning the system and to ensure good system performance.

In this example these fixed parameters are used:

BTS sensitivity (without diversity gain)	-106 dBm
BTS output Power	+41 dBm
Donor unit output power	+33 dBm
Remote unit output power	+40 dBm

#### 4.1.5.1 Downlink Path

The Downlink path is quite straightforward to set up in a repeater installation, and also gives a good indication of the actual path loss between the donor and the remote unit. The gain in the units is simply adjusted until the desired output levels are achieved. This procedure is simplified by the built in monitoring functions in the Avitec repeaters.

Remember though, that the repeater is not a piece of measurement equipment, and has a limited accuracy when presenting input and output levels. (+/-3dB and +/-2dB respectively)

Here two different link path losses will be analyzed, representing two extremes regarding the distance between the donor and remote unit: 6.5 and 26 kilometers. Free space path loss is assumed in both cases. (Feeder losses are varied to get further extreme values).

Total Link loss (6.5km):

$$-0.5 + 15 - 108 + 15 - 0.5 = -79\text{dB}$$

				-----	Feeder loss between Remote unit and Link antenna
			-----		Link antenna at Remote site 15dBi
		-----			Free space path loss at 925MHz / 6.5km
	-----				Link antenna at Donor site 15dBi
-----					Feeder loss between Donor unit and link antenna

Total Link loss (26km):

$$-2.5 + 15 - 120 + 15 - 2.5 = -95\text{dB}$$

				-----	Feeder loss between Remote unit and Link antenna
			-----		Link antenna at Remote site 15dBi
		-----			Free space path loss at 925MHz / 26km
	-----				Link antenna at Donor site 15dBi
-----					Feeder loss between Donor unit and link antenna

The downlink path based on the above link loss calculation for 6.5 and 26 kilometers.

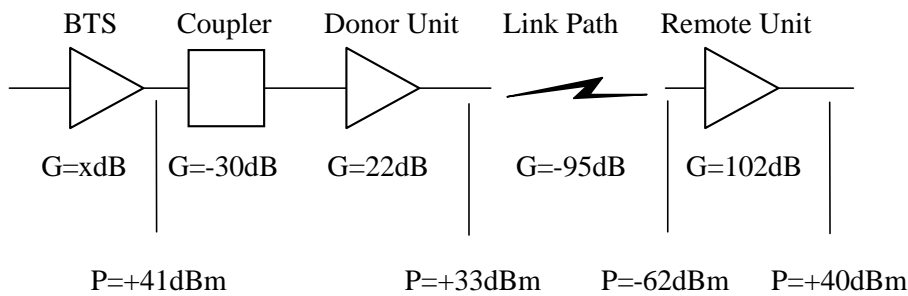
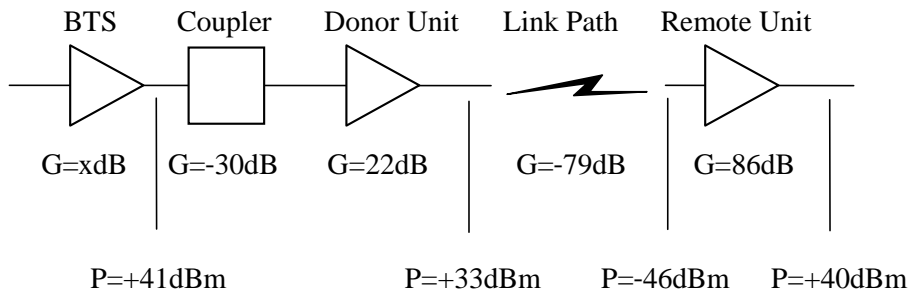

Note that the shorter link distance gives the opportunity to reduce the donor downlink gain and increase the remote downlink gain. This will reduce the output power in the link antenna and minimize interference caused by the link, and thereby simplify frequency planning.

The longer link distance is probably close to the maximum useful distance, since timing advance will only allow a repeater cell radius of 5-6 kilometers in this case. (The delay through the repeater chain is typically 2 x 6 us, equal to an increase of timing advance by 6-7 units)

In the case of a BTS with extended range capability longer link paths are possible, but then link antennas with more gain should be considered. 20dBi antennas have been used in some installations, reducing total link loss by 10dB compared to the above numbers. Keeping everything else constant, this would allow for another 23km of link distance.

**4.1.5.2 Uplink Path**

The settings of the Repeater Uplink path requires much more careful planning than the Downlink. Very different results can be obtained depending on the Repeater Uplink gain setting, and there will always be a trade off situation between the Repeater cell sensitivity and BTS cell sensitivity. Low Repeater Uplink gain will result in poorer Repeater cell sensitivity but only a small BTS cell sensitivity degradation. The opposite is also true; high Repeater Uplink gain will result in good repeater cell sensitivity but a larger reduction in BTS cell sensitivity.

The calculations to determine the sensitivity in the Repeater cell and the BTS cell is based on the formula for determining the total noise figure for a cascade of amplifiers and attenuators:

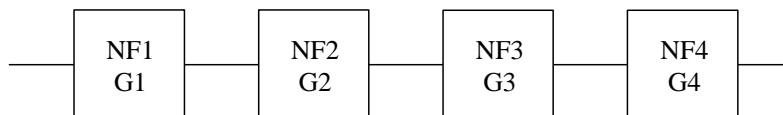

♦  $NF_{tot} = NF1 + (NF2-1)/G1 + (NF3-1)/(G1*G2) + (NF4-1)/(G1*G2*G3) + \dots$  (units, *not* dB's)

This equation is basically used to find the total noise figure at *two* points in the cascade made up by the repeater installation. Note that if there is a device in the chain that is affected by thermal noise from an

**PRODUCT DESCRIPTION AND USER'S MANUAL**

antenna, the equation has to be modified for that device. E.g. if device 3 is connected via an aerial connection, its contribution to the total gain is  $NF3/(G1*G2)$ .

5. The first point is the entire chain *including* the BTS receiver noise figure. This value is then directly used to calculate the repeater cell sensitivity.
6. The second point is the same cascade *excluding* the BTS receiver *and coupler* noise figure. This noise figure is, in combination with the gain to this point, converted to an equivalent noise floor. This is then added to the BTS receiver equivalent noise floor. The sum of the noise is then converted back to a noise figure used to calculate the BTS cell sensitivity.

First the equivalent BTS noise figure corresponding to the BTS sensitivity must be calculated from the following equation:

$$\text{Eq. BTS noise figure} = -106 - (-174 + 54 + 8) \text{ dB} = 6 \text{ dB}$$

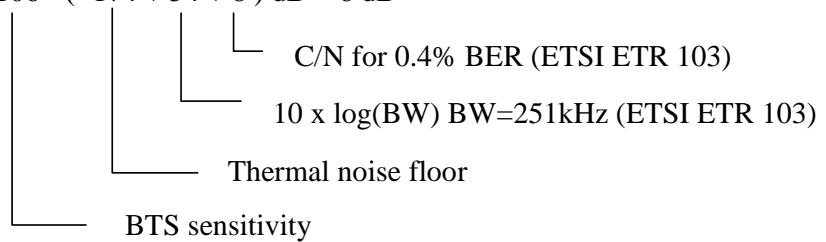

This value is used in all calculations below.

**Example 1: Rule of thumb setup with 26km link**

As a starting point ("rule of thumb") the uplink gain can be set equal to the downlink gain settings.

For the -95dB link this will give the situation shown in the figure below:

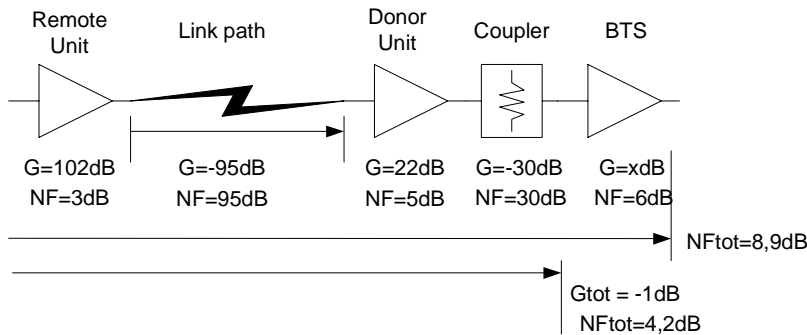

The 8.9dB noise figure through the repeater chain corresponds to a sensitivity of

$$-174 + 54 + 8 + 8.9 \text{ dBm} = -103.1 \text{ dBm}$$

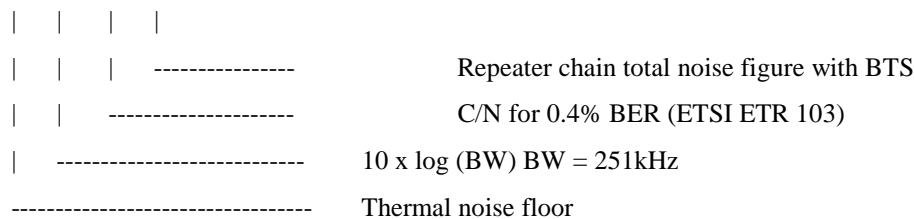

## PRODUCT DESCRIPTION AND USER'S MANUAL

---

The noise floor from the repeater chain at the BTS receiver input is:

$$-174 + 54 + 5.5 - 1 \text{ dBm} = -115.5 \text{ dBm}$$

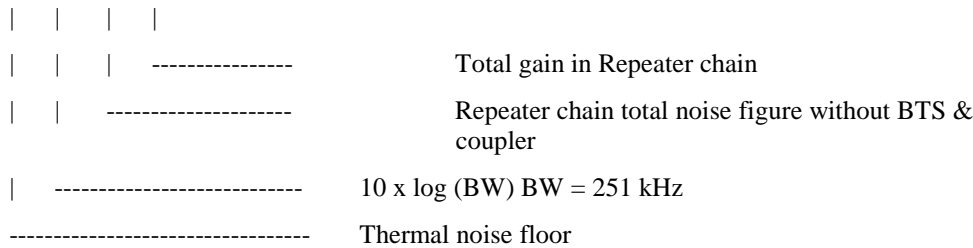

This must now be added to the BTS receiver noise floor, which is:

$$-174 + 54 + 6 \text{ dBm} = -114.0 \text{ dBm}$$

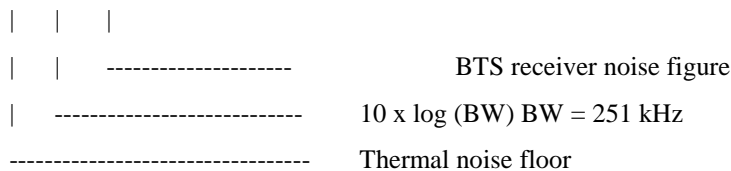

And when they are added the total noise floor at the BTS receiver input becomes:

$$10 * \text{LOG} [10^{(-115.5/10)} + 10^{(-114.0/10)}] = -111.7 \text{ dBm}$$

This is a 2.3dB higher BTS receiver noise floor compared to the starting value (114-111.7=2.3), which means that the BTS receiver sensitivity has degraded from -106 dBm to -103.7dBm without diversity.

Summary of example 1:

The calculations in example 1 used a very simple setup technique for the uplink path. The gain in the Uplink was simply set equal to the Downlink gain in both the Donor and Remote unit. This resulted in:

Sensitivity in Repeater cell = -103.1 dBm

Sensitivity in BTS cell = -103.7 dBm without diversity, a reduction of 2.3dB.

Note that the BTS Diversity receiver will maintain its original sensitivity of -106dBm since no Repeater noise is emitted into its input. However, the diversity gain will be lower than normal because of the Repeater noise emitted into the BTS main receiver input.

Also note that all traffic through the Repeater will only enter the BTS main receiver input, NOT the diversity receiver input. This may cause a "Diversity alarm" on some types of BTS's. This is normal and should be a simple matter of configuring the alarms in the BTS.

### Example 2: 26km link with high Repeater cell sensitivity

To get good Repeater cell sensitivity, the Uplink gain must be increased compared to example 1. If the gain from the Repeater server cell antenna to the BTS receiver antenna input is positive (larger than 0 dB), the Repeater can in fact be considered to be Tower Mounted Amplifier (TMA). The major difference is of course that the antenna is located 26km from the BTS in this case. The sensitivity of the original BTS cell will be degraded more than in example 1 because the noise floor will be higher at the BTS receiver input.

The example 2 setup looks like the figure below:

PRODUCT DESCRIPTION AND USER'S MANUAL

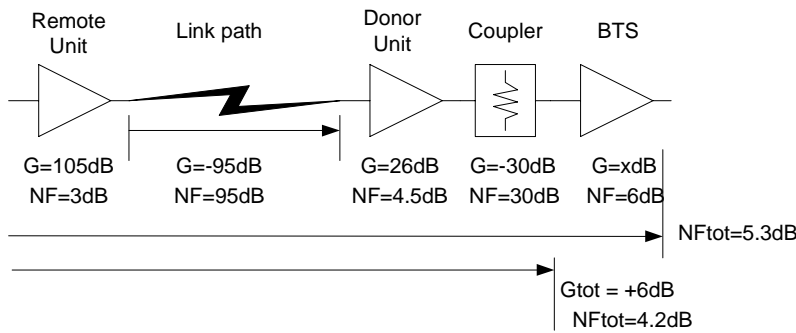

Doing the calculations yields:

Sensitivity in Repeater cell = -106.7 dBm

Sensitivity in BTS cell = -100.2 dBm without diversity, a reduction of 5.8dB.

It is obvious that the increased Uplink gain has improved Repeater cell sensitivity on the cost of the BTS cell sensitivity.

Example 3: 6.5km link with 2dB lower gain in the downlink compared to uplink

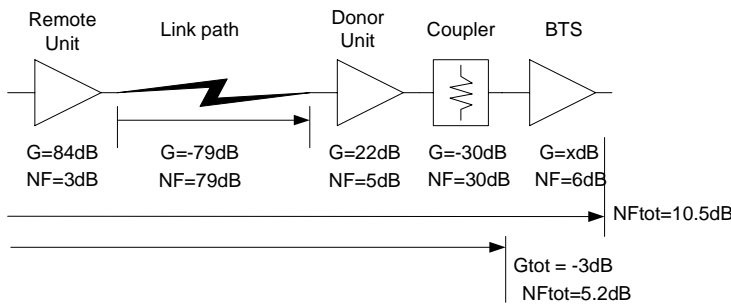

Doing the calculations yields:

Sensitivity in Repeater cell = -101.5 dBm

Sensitivity in BTS cell = -104.5 dBm without diversity, a reduction of 1.5dB.

This example shows a relatively small reduction in the BTS cell sensitivity on the cost of a rather poor Repeater cell sensitivity. In this case however, it is possible to increase the Uplink gain in the Remote unit and reduce it equally much in the Donor unit. This will improve the overall noise figure as dictated by the NFtot equation on page 3. This is examined in the next example.

Example 4: 6.5km link with high BTS sensitivity and optimized Repeater sensitivity

The Donor Uplink gain in example 3 was 22dB. Since the minimum configurable gain in the Donor unit is 12dB, it can be reduced by 10dB. This is compensated for in the Remote unit and this setup looks like:

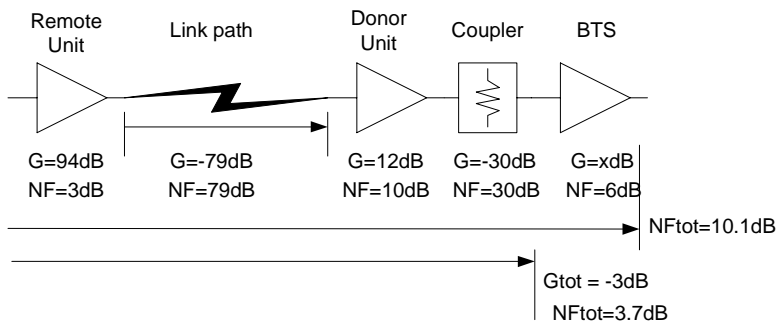

## PRODUCT DESCRIPTION AND USER'S MANUAL

Doing the calculations yields:

Sensitivity in Repeater cell = -101.9 dBm

Sensitivity in BTS cell = -104.9 dBm without diversity, a reduction of 1.1dB.

Although the improvement compared to Example 3 is only a few tens of a dB, the "cost" of the improvement is just a few moments of calculations. With more total Uplink gain the improvement is larger. See the next example.

### Example 5: 6.5km link with optimised Repeater sensitivity

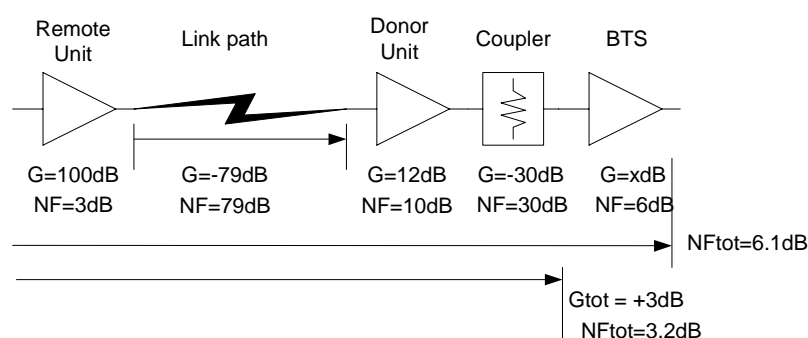

Doing the calculations yields:

Sensitivity in Repeater cell = -105.9 dBm

Sensitivity in BTS cell = -102.9 dBm without diversity, a reduction of 3.1dB.

Compared to example 4, the repeater sensitivity has been improved by 4dB but the BTS sensitivity has been reduced by 2dB.

## Summary

It has been shown by several calculation examples that some care is needed when the Uplink gain is configured in a CSFT installation if optimum sensitivity is desired. However, "rule of thumb" setup will only cause a small BTS sensitivity degradation with a typical BTS, but Repeater cell sensitivity will not be optimum.

Note that feeder losses between Repeater server antenna and Remote unit are **not** included in the calculations.

## 4.1.6 Engineering Considerations

### 4.1.6.1 Channel Separation

Avitec recommends a spacing of two GSM channels between the carriers in the amplifier chains. These two "guard channels" create a centre-to-centre separation of 600 kHz.

Decreasing the spacing may lead to degraded performance.

### 4.1.6.2 Minimum Link Channel Spacing

When setting up a frequency translating repeater Avitec recommends a spacing of two GSM channels between the link frequency and the radio frequency. These two "guard channels" create a centre-to-centre separation of 600 kHz.

Decreasing the spacing may lead to degraded performance.

#### 4.1.6.3 Gain Adjustment

Use only the required power to cover blind spots or coverage areas, to minimize border overlap with the donor BTS

Optimize repeater gain levels to achieve system path balance and an acceptable noise level contribution

Reflections, phase fluctuations and other variables can all affect the quality of radio traffic and on site adjustments and measurement will always have to be carried out to ensure reliable radio communication.

#### 4.1.6.4 Overlapping Coverage

Ideally, the repeater system will be engineered with minimal overlapping coverage between the donor base station and the repeater. However, the mobile unit will occasionally receive signals from both the donor and the repeater at similar levels. This situation is comparable to a mobile receiving multiple signals at varying times due to multi-path propagation.

The GSM standards require that systems must accommodate up to 16 $\mu$ s of multi-path delay for two received signals that are less than or equal to 10dB apart. The CSR922 repeater contributes a maximum signal delay of 6 $\mu$ s.

#### 4.1.6.5 Are calls possible on link frequencies for frequency translating repeaters?

Calls cannot be connected via the link frequencies for the following reasons.

The mobile station (MS) searches for the Broadcast Control Channel (BCCH) beamed from the Base Transceiver Station (BTS) Even though the MS may find the frequency translated link signal BCCH transmission; it will not be possible to initiate a call through it.

When a call is initiated, the BTS switches from BCCH to the Stand Alone Control Channel (SDCCH), which (apart from other information) instructs the MS which frequency (ARFCN) to use during the call. This makes the MS switch back to the non-frequency translated ARFCN (BTS frequency), where it will find no BTS signal and the call is aborted. The same is true when logging into the network.

**Note!** The BCCH, SDCCH, and TCH channels are logical GSM channels, not to be confused with Absolute Radio Frequency Channels (ARFCN). Only the latter are associated with specific frequencies.

#### 4.1.6.6 Frequency Hopping and Repeaters

Frequency hopping usually means that the input baseband traffic at frame level is switched between fixed frequency RF-channels. In order for the hopping to be effective, four or more channels are used. The Avitec channel selective repeater with appropriate number of channels can function with this kind of hopping.

However, frequency hopping can also mean that the frequency of each transceiver is changed in phase with transmission frames. This is usually called synthesized hopping. Being more complex than the baseband type, it has not been widely implemented in GSM networks.

When GSM is evolving into EDGE, traffic will be IP-packet based. IP-traffic studies show that frequency hopping does not improve the capacity or performance of the channel. A tendency is that frequency hopping will not be frequently used in EDGE networks.