

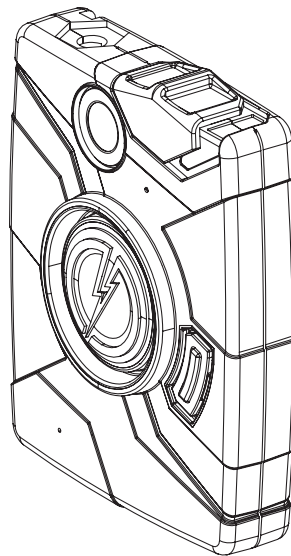

TASER

Axon Body Camera

User Manual



IMPORTANT SAFETY INSTRUCTIONS.

Read all warnings and instructions. Save these instructions.

The most up-to-date warnings and instructions are available at www.TASER.com.

MMU0046 Rev: C

Contents

- 3 Chapter 1: Introduction**
 - 3 What Is the Axon Body System?
 - 3 Additional Reading

- 4 Chapter 2: Getting to Know Your Axon Body Camera**
 - 5 Accessories

- 7 Chapter 3: Recording with the Axon Body Camera**
 - 7 Operating Modes
 - 7 BUFFERING Mode
 - 8 EVENT Mode
 - 8 Battery Status
 - 8 Adjusting the Audio Prompt Volume
 - 9 Turning off the Camera LEDs

- 10 Chapter 4: Audio Prompts**

- 11 Chapter 5: Care and Maintenance**
 - 11 Cleaning the Axon Body Camera
 - 11 Charging the Battery

- 12 Chapter 6: Troubleshooting**
 - 12 Reset Functioning
 - 12 Customer Service
 - 12 Warranty Policy
 - 12 Warnings
 - 13 Radio Waves

- 15 Chapter 7: CE Declaration of Conformity**

What Is the Axon Body System?

The Axon Body camera is a camera system incorporating an audio and video recording device. This camera is designed for use in tough environmental conditions encountered in law enforcement, corrections, military, and security activities. The Axon Body camera is designed to record events in real time for secure storage, retrieval, and analysis via the Evidence.com services or in an offline configuration to your local computer. The recorded events are transferred to your storage solution via the evidence transfer manager (ETM), the Evidence.com Dock, or by using Evidence Sync software installed on a Windows computer.

The Axon Body camera has two operating modes designed to accommodate the needs of law enforcement, corrections, security, and the military. The default mode, or BUFFERING mode, provides pre-event buffering to capture activities that occur prior to the user activating the EVENT mode. In addition, the Axon Mobile application enables playback of footage on a smart phone for review prior to storing the data.

Instructional videos for using Axon systems are available at www.TASER.com under Training Videos.

Additional Reading

This manual explains how to operate the Axon Body camera hardware. Other manuals cover additional aspects of the Axon Body system. These documents are available at www.TASER.com.

The *TASER Axon System End-to-End Deployment Guide* explains how to register for the Evidence.com website, configure settings, install Evidence Sync software, assign personnel to cameras, recharge your camera, and transfer video from an Axon device to a computer.

Detailed instructions for using Axon cameras and other TASER products with Evidence Sync are available in the *Evidence Sync User Manual*.

For instructions on using your Axon camera with a smart device, see the *Axon Mobile for Android Devices User Manual* or the *Axon Mobile for IOS Devices User Manual*, as appropriate.

If you have an Evidence.com Dock, see the *Evidence.com Dock User Manual* for how to transfer information and recharge your camera.

Getting to Know Your Axon Body Camera

2

The Axon Body camera includes physical controls to enable video capture with audio records while providing visual and audible notifications of the Axon Body camera's state of operation.

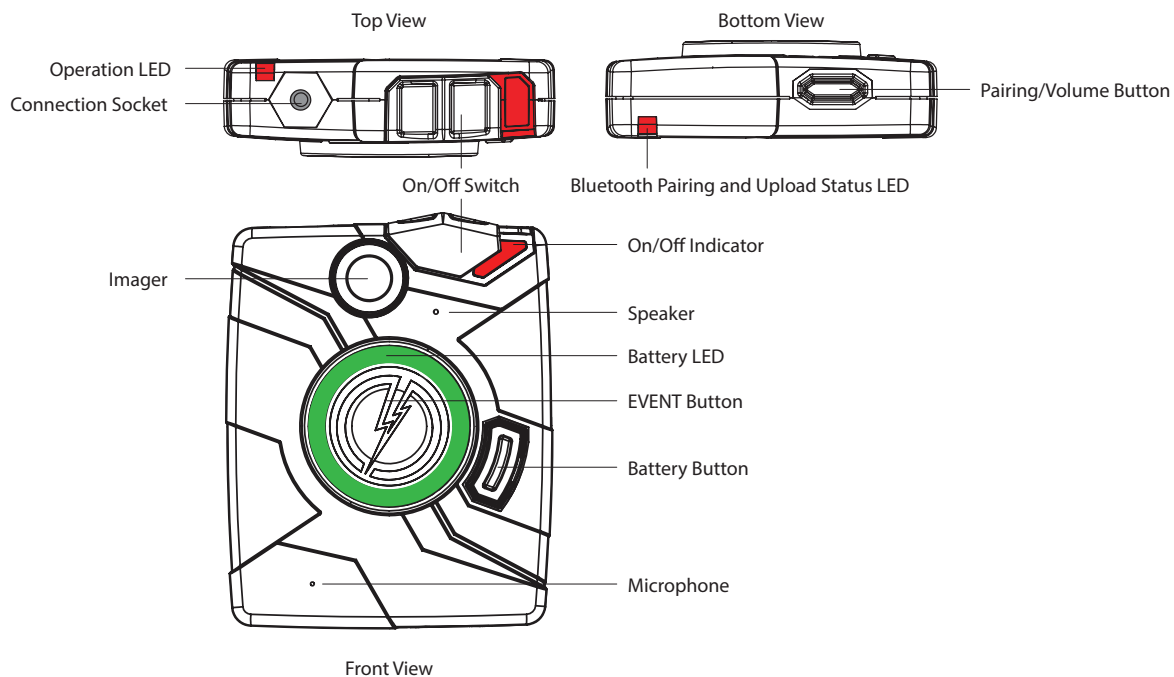

1 Operation LED – Shows the Axon Body camera's current operating mode:

Operating Mode	Operation LED
Recording	Blinking red
Buffering	Blinking green
Booting up/powering down	Solid red

NOTE: For battery status, see the Battery LED, described below.

- 2 Connection Socket** – Enables data transfer and recharging.
- 3 On/Off Switch** – Turns the camera's power on or off.
- 4 On/Off Indicator** – When the camera's power is turned on, the red portion is exposed. When the camera power is turned off, the red portion is covered from view.
- 5 Speaker** – Provides audio notifications.

- 6 **EVENT Button** – Used to start and stop recording. (Double-press to start; hold for 3 seconds to stop recording.)
The camera might take several additional seconds to close out of the video when it is taken out of EVENT mode.
- 7 **Battery Button** – When pressed, the Battery button lights up the Battery LED, which momentarily indicates the remaining battery capacity only (it does not indicate the operating mode).
- 8 **Battery LED** – When lit, momentarily indicates the remaining battery capacity (it does not indicate the operating mode).

Battery Status	Battery LED
Battery capacity is 41–100 percent.	Green
Battery capacity is 20–40 percent.	Yellow
Battery capacity is less than 20 percent.	Red during operation; flashing red and yellow during charging
Battery is critically low	Blinking red and yellow

When you turn the camera on, the operation LED turns solid red until the system is ready to use. Then the Operation LED blinks green (BUFFERING mode) and the Battery LED goes out.

- 9 **Microphone** – For audio recording.
- 10 **Pairing/Volume Button** – When pressed, adjusts the volume of audio prompts. It also is used to pair the Axon Body camera with a smart mobile device (e.g., phone or tablet).
- 11 **Bluetooth Pairing and Upload Status LED** – Indicates status when the camera is downloading data to your computer or uploading data to Evidence.com. This LED also indicates status when you are configuring your Axon Body camera to work with a mobile device such as a smart phone.
- 12 **Imager** – The camera lens.

Pressing buttons causes the Axon Body camera to emit audio alerts (beeps) to indicate system actions. See *Chapter 4: Audio* for more information.

Accessories

The Axon Body camera is designed to be worn in a holster that can be clipped to your shirt. The holster incorporates a plug that goes into the camera’s connection socket when the camera is holstered. The plug is intended to filter excessive ambient noise and prevent dust debris from entering the socket.

Additional holster options are available. Visit www.TASER.com for more information.

Keep the plug inserted into the connection socket. If the plug is not plugged into the socket, audio recording will be distorted.

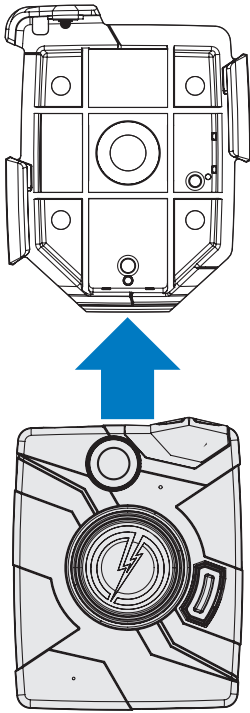

Ensure the Axon Body camera is completely inserted into holster.

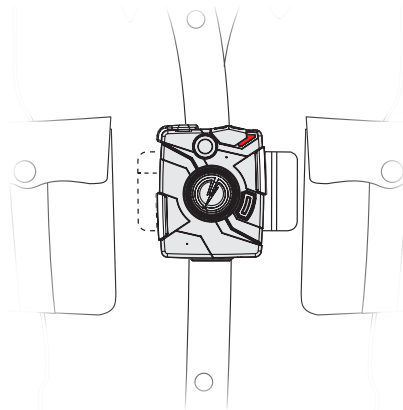
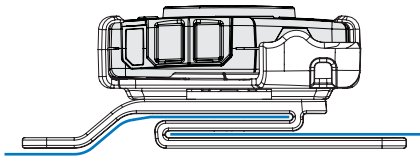

When you are wearing the camera, you can use the Axon Mobile application's live streaming feature to determine whether your camera is capturing the view you intended. See the ***Axon Mobile Application for Android Devices User Manual*** or ***Axon Mobile Application for IOS Devices User Manual*** for more information.

Operating Modes

The Axon Body camera has two operating modes:

- 1 BUFFERING
- 2 EVENT

BUFFERING Mode

- 1 Move the ON/OFF switch on the camera to the ON position.

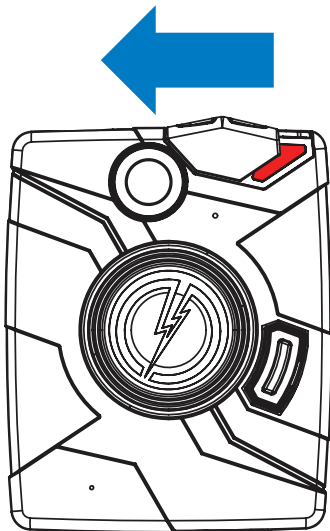

With the camera turned on, the Axon system is in the BUFFERING mode. When BUFFERING begins:

- The Operation LED on the camera will blink green.
- The camera will be capturing video but no audio, and will not record to permanent memory while in BUFFERING mode.
- Buffered video duration is up to 30 seconds (00:00:30).

When you activate the EVENT mode, the buffered video (not audio) captured directly before the event, up to 30 seconds, will be saved and attached to the event in permanent memory. This feature is intended to capture the video of an incident just before your activation of EVENT mode.

Because the system does not capture audio in BUFFERING mode, the first 30 seconds of a recorded event will be video-only. Buffering mode starts only after the Axon Body camera is turned on. The system does not record when the camera is turned off.

NOTE: An agency can turn off the BUFFERING mode. If your agency has deactivated the BUFFERING mode, your Axon system will operate the same way as described in this manual, but the camera will not record anything until you double-press the EVENT button.

EVENT Mode

- 1 When you need to record, quickly double-press the EVENT button on the camera.

The system now records audio as well as video. The “buffered” video directly preceding the event will be saved and attached to the event recording. (Remember, the buffered video will not contain audio.) The moment you double-press the EVENT button, both video and audio will be recorded from the camera and GPS coordinates (if the system is paired to a GPS-capable smart phone) will be recorded. This will continue throughout the duration of the recording until you terminate the recording.

The camera provides you with indications that it is recording in EVENT mode:

- At the start of an event and every 2 minutes during an event, the system will beep twice.
 - The Operation LED on top of the camera will blink red.
- 2 To stop recording and return to BUFFERING mode, press and hold the EVENT button for approximately 3 seconds. The system will beep once.
 - 3 To end a recording and turn off the system, move the on/off switch to the “off” position. When you end a recording with the on/off switch you will not go into BUFFERING mode; instead the system will turn off completely.

NOTE: An event not recorded by the camera cannot be played back or downloaded to your computer.

Battery Status

Press the Battery button to determine the percentage remaining in the battery. See *Chapter 2 Getting to Know Your Axon Body Camera* for details on the battery LED functions.

Adjusting the Audio Prompt Volume

Press the volume/pairing button on the camera to adjust the volume of the audio prompts.

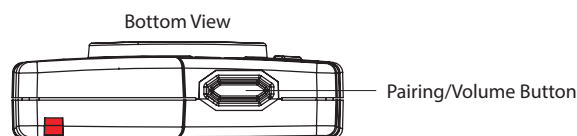

The volume has four settings. At each level, the camera beeps, providing you with a sample of the volume:

- Low
- Medium

- High
- Off

Other than the audio prompt beeps heard on the audio recordings, the volume/pairing button has no effect on the audio recording captured by the camera.

Turning off the Camera LEDs

For some situations, you may wish to turn off the lights on your camera.

- 1 Press and hold the Battery button for 10 seconds.
 - The Operation LED flashes red, yellow, and then green before shutting down the lights.
 - Pressing the Battery button will momentarily light both the Operation LED and the Battery LED, displaying the current operating mode and battery level. For interpreting the LED colors, see ***Chapter 2 Getting to Know Your Axon Body Camera***.
- 2 To turn the lights back on, press and hold the Battery button for 10 seconds.

The Axon Body camera emits beeping sounds called “audio prompts” to notify you of the system status. These audio prompts usually occur after you perform an action with the body camera.

Operating Mode	Audio Notification
Powering on or off	One beep
Recording an event	Two beeps (every two minutes)
Press the Battery button while the camera is recording	Two beeps
The device is ending an event and returning to BUFFERING mode	One long beep
The battery is at 20 percent capacity or lower	Four quick beeps (every 20 seconds)
The camera memory is full	Three beeps. The camera will not start recording.

Cleaning the Axon Body Camera

Use a soft, damp cloth to clean the surface of the Axon Body camera. Do not use harsh cleaners or solvents.

Do not immerse the Axon Body camera in water or cleaning solutions.

If the Axon Body camera lens becomes dirty, use a lens blower brush to clean it and then wipe it with a soft cloth if necessary.

You may moisten the cloth with isopropyl alcohol.

- Do not use Windex or similar type cleaners on the camera lens.
- Do not place the lens under running water or apply jets of water to the camera lens.

Charging the Battery

A fully charged camera battery should provide enough power for approximately 12 hours of normal operation. Recharging a battery after a 12-hour use can take up to 6 hours if you are recharging your Axon Body camera from a wall outlet, Evidence.com Dock, or an ETM. Recharging could take considerably longer if you are recharging from a computer.

If the battery depletes significantly during use, you will hear 4 quick tones repeating every 20 seconds. This message indicates that less than approximately 20 percent of the battery capacity remains.

Always recharge a depleted battery as soon as reasonably possible. You can use an ETM, Evidence.com Dock, wall charger, or computer to charge the battery. Using a non-TASER approved wall charger may degrade device performance and will void the warranty.

If you experience difficulty with your Axon Body camera, first power the device down, and start it again.

If experiencing difficulty with the Axon Mobile application, power down the mobile device, turn the device back on, and re-pair your smart device with the Axon Body camera. See the *Axon Mobile for Android Devices User Manual* or *Axon Mobile for IOS Devices User Manual*, as appropriate, for more information.

Reset Functioning

You might experience a reset while operating the Axon Body camera. During a reset, the camera will shut down, restart, and return to the mode (BUFFERING or EVENT) in which it was operating before the reset occurred.

If a reset occurs in BUFFERING mode, the camera will beep once while shutting down. The LED will go from blinking green (BUFFERING mode) to blinking yellow, and then it will turn solid red. The LED will then cycle back through solid red (booting). The camera will then beep once, and the LED will blink green (BUFFERING). This will repeat until the Axon system is booted up.

If the reset occurs in the EVENT mode, the camera will beep once while shutting down. The LED will go from blinking red (EVENT mode) to blinking yellow, and then it will turn solid red. The LED will then cycle back through solid red (booting). The camera will then beep once, and the LED will blink green (BUFFERING) and then blink red (EVENT). This will repeat until the camera is booted up.

Customer Service

Visit www.TASER.com and view the Support options.

Warranty Policy

TASER International warranty provisions are applicable on all Axon Body system products. See TASER International's website, www.TASER.com, for detailed warranty information.

Warnings

For a full list of the warning associated with this product, see www.TASER.com.

Radio Waves



Changes or modifications to the equipment not expressly approved by the manufacturer could void the product warranty and the user's authority to operate the equipment.

Your wireless device is a radio transmitter and receiver. It is designed and manufactured not to exceed the emission limits for exposure to radio frequency (RF) energy set by the Federal Communications Commission (FCC) of the U.S. Government. These limits are part of comprehensive guidelines and establish permitted levels of RF energy for the general population. The guidelines are based on standards that were developed by independent scientific organizations through periodic and thorough evaluation of scientific studies. The standards include a substantial safety margin designed to assure the safety of all persons, regardless of age and health. Before a device model is available for sale to the public, it must be tested and certified to the FCC that it does not exceed the limit established by the government-adopted requirement for safe exposure. This equipment has been tested and found to comply with the limits for a Class B digital device, pursuant to part 15 of the FCC Rules. These limits are designed to provide reasonable protection against harmful interference in a residential installation. This equipment generates, uses and can radiate radio frequency energy and, if not installed and used in accordance with the instructions, may cause harmful interference to radio communications. However, there is no guarantee that interference will not occur in a particular installation. If this equipment does cause harmful interference to radio or television reception, which can be determined by turning the equipment off and on, the user is encouraged to try to correct the interference by one or more of the following measures:

- Reorient or relocate the receiving antenna
- Increase the separation between the equipment and receiver.
- Connect the equipment into an outlet on a circuit different from that to which the receiver is connected.
- Consult TASER International Customer Service for help.

FCC/IC NOTICE: This device meets the body worn human exposure limits found in OET Bulletin 65, 2001, and ANSI/IEEE C95.1, 1992. Proper operation of this equipment according to the instructions found in this guide will result in exposure substantially below the FCC's recommended limits. To comply with the FCC and ANSI C95.1 RF exposure limits, this device has been tested for compliance with FCC RF Exposure limits in the typical configuration. The radiated output power of this wireless device is far below the FCC radio frequency exposure limits.

Section 7.1.3 of RSS-GEN

This Device complies with Industry Canada License-exempt RSS standard(s). Operation is subject to the following two conditions: 1) this device may not cause interference, and 2) this device must accept any interference, including interference that may cause undesired operation of the device.

Cet appareil est conforme aux normes d'exemption de licence RSS d'Industrie Canada. Son utilisation est soumise aux conditions suivantes : 1) cet appareil ne doit pas causer de brouillage, et 2) doit accepter tout brouillage, y compris le brouillage pouvant entraîner un fonctionnement indésirable.

Section 7.1.2 of RSS-GEN

Under Industry Canada regulations, this radio transmitter may only operate using an antenna of a type and maximum (or lesser) gain approved for the transmitter by Industry Canada. To reduce potential radio interference to other users, the antenna type and its gain should be so chosen that the equivalent isotropically radiated power (e.i.r.p.) is not more than that necessary for successful communication.

Conformément à la réglementation d'Industrie Canada, le présent émetteur radio ne peut fonctionner qu'au moyen d'une antenne d'un seul type et d'un gain maximal (ou inférieur) approuvé pour l'émetteur par Industrie Canada. Dans le but de réduire les risques de brouillage radioélectrique pour les autres utilisateurs, il faut choisir le type d'antenne et son gain de sorte que la puissance isotrope rayonnée équivalente (p.i.r.e.) ne dépasse pas celle requise pour établir une communication satisfaisante.

THIS MODEL DEVICE MEETS THE GOVERNMENT'S REQUIREMENTS FOR EXPOSURE TO RADIO WAVES.

CE Declaration of Conformity



7

TASER International declares that this Axon system is in compliance with the essential requirements and other relevant provisions of Directive 1999/5/EC. A copy of the original Declaration of Conformity can be found at www.TASER.com.



Product functions and specifications may change without notice and the actual product may vary from the illustrations in this manual.

Android is a trademark of Google, Inc., Bluetooth is a trademark of Bluetooth SIG, IOS is a trademark of Cisco Technology, Inc., and Windex is a trademark of S. C. Johnson & Son, Inc.

Evidence.com and  AXON are trademarks of TASER International, Inc., and Axon and  are trademarks of TASER International, Inc., registered in the US and other countries. For more information, visit www.TASER.com/legal. All rights reserved.

© 2015 TASER International, Inc.