



UNII Config & User Guide

version 5.2

March 10, 2003

Company Confidential

Axxcelera Broadband Wireless

175 Science Pkwy.

Rochester, NY 14620

1 Revision History

Version	Date	Author	Comments
5.0	Jan 9, 02	Matt Olson	Updated for 5.0 system software
5.0	Jan 14, 2002	Joe Higgs	Format edits
5.0	Feb 19, 2002	Matt Olson	More 5.0 updates
5.0	Feb 20, 2002	Matt Olson	Added sections from old UNII Config & User Guide.
5.1	Dec 13, 2002	Matt Olson	Updated for the 5.1.8 System Software & 5.1.6 EMS.
5.2.x	Apr 17, 2003	Matt Olson	Updated for the 5.2.x System software.

PLEASE READ THESE SAFETY PRECAUTIONS!

RF Energy Health Hazard



The radio equipment described in this guide uses radio frequency transmitters. Although the power level is low, the concentrated energy from a directional antenna may pose a health hazard. **Do not allow people to come in within 20cm to the front of the antenna while the transmitter is operating.**

Protection from Lightning

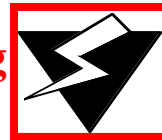

Article 810 of the US National Electric Department of Energy Handbook 1996 specifies that radio and television lead-in cables must have adequate surge protection at or near the point of entry to the building. The code specifies that any shielded cable from an external antenna must have the shield directly connected to a 10 AWG wire that connects to the building ground electrode.

FCC Notice, USA

The AB-Access units comply with Part 15 of the FCC rules. Operation is subject to the following two conditions:

- This device may not cause harmful interference.
- This device must accept any interference received including interference that may cause undesired operation.

This device is specifically designed to be used under Part 15, Subpart E of the FCC Rules and Regulations. Any unauthorized modification or changes to this device without the express approval of Axxcelera Broadband may void the user's authority to operate this device. Furthermore, this device is intended to be used only when installed in accordance with the instructions outlined in this manual. Failure to comply with these instructions may also void the user's authority to operate this device and/or the manufacturer's warranty

Conditions specific to AB-Extender:

AB-Extender complies with Part 15 of the FCC rules. The device is specifically designed to be used under Part 15, Sub-part E of the FCC rules and regulations. Operation is subject to following conditions:

- The device to utilize a fixed mount antenna, for use on a permanent outdoor structure.
- The device to be installed by qualified installation/deployment personnel, and a minimum of 1.5 meters of separation must exist between the device and persons, when the device is operating.
- The device installers and operators should be aware of the transmitter operating conditions, specified in the AB-Extender installation manual and other associated user documentation, as well as the antenna co-location requirements of Part 1.1307 (b) (3), of FCC rules, pertaining to RF exposure.
- The device may not cause harmful interference.
- The device must accept interference received, including interference that may cause undesired operation.

The device is intended to be used only when installed in accordance with instructions outlined in this manual. Failure to comply with these instructions may void the user's authority to operate this device and/or the manufacturer's warranty. Furthermore, any unauthorized modification or changes to this device without the express approval of Axxcelera Broadband may also void the user's authority to operate this device.

Table of Contents

1	Revision History.....	2
	<u>PLEASE READ THESE SAFETY PRECAUTIONS!</u>	3
2	Document Overview	11
3	AB-Access Overview	12
3.1	Topologies.....	12
3.1.1	CLIP (RFC 1577)	12
3.1.2	1483 Bridging (RFC 1483).....	12
3.1.3	Native ATM	12
3.1.4	PPPoA (RFC 2364).....	12
4	AB-Access Reference Model	13
4.1	Subnetting	14
4.2	Peak Cell Rate - PCR	14
4.3	ATM Switch.....	15
5	Static Configurations.....	16
5.1	resolve	16
5.1.1	device	16
5.1.2	nat	17
5.1.3	subnet.....	17
5.1.4	rip accept.....	17
5.1.5	rip send.....	18
5.1.6	rip relay.....	18
5.1.7	route add	18
5.1.8	ipatm lifetime	19
5.1.9	relay	19
5.1.10	ipatm pvc add	19
5.2	system.conf.....	21
5.2.1	channel	21
5.2.2	antenna.....	21
5.2.3	mode	21
5.2.4	mid	22
5.2.5	bid	22
5.2.6	interface.....	22
5.2.7	duplex.....	23
5.2.8	backoff.....	23
5.2.9	provider	23
5.2.10	key.....	23
5.2.11	mask	24
5.2.12	leds	25
5.2.13	max_mid	25
5.3	initswitchcli	25
5.3.1	tp	25
5.3.2	sp	26
5.3.3	add	26
5.4	initmr1483.....	27
5.4.1	floodmode	27
5.4.2	up	28
5.5	initr1483	28
5.5.1	pvc	28
5.6	initbridge.....	29
5.6.1	spanning.....	29
5.6.2	device add.....	29

- 5.7** **dhcpd.conf**.....**30**
 - 5.7.1** **subnet**.....**30**
 - 5.7.2** **range**.....**30**
 - 5.7.3** **option routers****30**
 - 5.7.4** **max-lease-time**.....**31**
 - 5.7.5** **option domain-name****31**
 - 5.7.6** **option domain-name-servers****31**
- 5.8** **snmpinit**.....**31**
 - 5.8.1** **access write****31**
- 6** **CLIP_T**.....**33**
 - 6.1** **Interactive CLIP_T Eth AP**.....**33**
 - 6.1.1** **Adding AP and SU to EMS****33**
 - 6.1.2** **Troubleshooting****35**
 - 6.1.2.1 AP Object 35
 - 6.1.2.2 SU Object 36
 - 6.2** **Static CLIP_T Eth AP**.....**38**
 - 6.2.1** **AP Configuration Files**.....**39**
 - 6.2.1.1 AP resolve 39
 - 6.2.1.2 AP system.conf..... 39
 - 6.2.2** **SU Configuration Files**.....**40**
 - 6.2.2.1 SU resolve 40
 - 6.2.2.2 SU system.conf 40
 - 6.2.3** **Troubleshooting****41**
 - 6.2.3.1 Can't ping the radio from the terrestrial interface 41
 - 6.2.3.2 Can't ping across the wireless link 41
 - 6.3** **Static CLIP_T ATM AP**.....**42**
 - 6.3.1** **AP Configuration Files**.....**43**
 - 6.3.1.1 AP resolve 43
 - 6.3.1.2 AP system.conf..... 43
 - 6.3.2** **SU Configuration Files**.....**44**
 - 6.3.2.1 SU resolve 44
 - 6.3.2.2 SU system.conf 44
 - 6.3.3** **Troubleshooting****45**
 - 6.3.3.1 Can't ping the radio from the terrestrial interface 45
 - 6.3.3.2 Can't ping across the wireless link 47
 - 6.4** **Hybrid CLIP_T Eth AP****48**
 - 6.4.1** **AP Configuration Files**.....**49**
 - 6.4.1.1 AP resolve 49
 - 6.4.1.2 AP system.conf..... 49
 - 6.4.1.3 AP Switchcli..... 50
 - 6.4.2** **SU1 Configuration Files**.....**50**
 - 6.4.2.1 SU1 resolve 50
 - 6.4.2.2 SU1 system.conf 51
 - 6.4.3** **SU2 Configuration Files**.....**51**
 - 6.4.3.1 SU2 resolve 51
 - 6.4.3.2 SU2 system.conf 52
 - 6.4.4** **Troubleshooting****52**
 - 6.4.4.1 Can't ping the radio from the terrestrial interface 52
 - 6.4.4.2 Can't ping across the wireless link 52
- 7** **CLIP_S**.....**54**
 - 7.1** **CLIP_S Interactive****54**
 - 7.1.1** **Adding AP and SU to EMS****55**
 - 7.1.2** **Troubleshooting****56**
 - 7.1.2.1 AP Object 56
 - 7.1.2.2 SU Object 57
 - 7.2** **Static CLIP_S (routed management)****60**

7.2.1	Routed Management PRO/CON	60
7.2.2	AP Configuration Files	61
7.2.2.1	AP resolve	61
7.2.2.2	AP system.conf.....	61
7.2.2.3	AP initswitchcli.....	62
7.2.3	SU Configuration Files	62
7.2.3.1	SU resolve	62
7.2.3.2	SU system.conf	63
7.2.4	Troubleshooting	63
7.2.4.1	Can't ping the radio from the terrestrial interface	63
7.2.4.2	Can't ping across the wireless link	65
7.3	Static CLIP_S (switched management)	67
7.3.1	Switched Management PRO/CON	67
7.3.2	AP Configuration Files	68
7.3.2.1	AP resolve	68
7.3.2.2	AP system.conf.....	68
7.3.2.3	AP initswitchcli.....	69
7.3.3	SU Configuration Files	69
7.3.3.1	SU resolve	69
7.3.3.2	SU system.conf	70
7.3.4	Troubleshooting	70
7.3.4.1	Can't ping the radio from the terrestrial interface	70
7.3.4.2	Can't ping across the wireless link	71
8	Hybrid CLIP_S	73
8.1.1	AP1 Configuration Files	73
8.1.1.1	AP1 resolve	73
8.1.1.2	AP1 system.conf.....	74
8.1.1.3	AP1 initswitchcli.....	75
8.1.2	SU1 Configuration Files	75
8.1.2.1	SU1 resolve	75
8.1.2.2	SU1 system.conf	76
8.1.3	AP2 Configuration Files	76
8.1.3.1	AP2 resolve	76
8.1.3.2	AP2 system.conf.....	77
8.1.3.3	AP2 initswitchcli.....	77
8.1.4	SU2 Configuration Files	78
8.1.4.1	SU2 resolve	78
8.1.4.2	SU2 system.conf	78
8.1.5	Troubleshooting	79
8.1.5.1	Can't ping the radio from the terrestrial interface	79
8.1.5.2	Can't ping across the wireless link	81
9	1483_T	82
9.1	Interactive 1483_T	82
9.1.1	Adding AP or SU to EMS	82
9.1.2	Troubleshooting	84
9.1.2.1	AP Object	84
9.1.2.2	SU Object	85
9.2	Static 1483_T	87
9.2.1	AP Configuration Files	87
9.2.1.1	AP resolve	87
9.2.1.2	AP initbridge	88
9.2.1.3	AP initmr1483	88
9.2.1.4	AP system.conf.....	88
9.2.2	SU Configuration Files	88
9.2.2.1	SU resolve	88
9.2.2.2	SU initbridge.....	89

9.2.2.3	SU system.conf	89
9.2.2.4	SU inetr1483.....	89
9.2.3	Troubleshooting	89
9.2.3.1	Can't ping the radio from the terrestrial interface.....	89
9.2.3.2	Can't ping the radio across the wireless link.....	90
10	1483_S.....	91
10.1	Interactive 1483_S	91
10.1.1	Adding AP and SU to EMS	92
10.1.2	Troubleshooting	93
10.1.2.1	AP Object	93
10.1.2.2	SU Object.....	94
10.2	Static 1483_S (routed management).....	97
10.2.1	Routed Management PRO/CON	97
10.2.2	AP Configuration Files.....	98
10.2.2.1	AP resolve	98
10.2.2.2	AP system.conf.....	98
10.2.2.3	AP initswitchcli.....	99
10.2.3	SU Configuration Files.....	99
10.2.3.1	SU resolve.....	99
10.2.3.2	SU initbridge.....	99
10.2.3.3	SU system.conf	100
10.2.3.4	SU inetr1483.....	100
10.2.4	Troubleshooting	100
10.2.4.1	Can't ping the radio from the terrestrial interface.....	100
10.2.4.2	Can't ping the radio across the wireless link.....	102
10.3	Static 1483_S (switched management)	104
10.3.1	Switched Management PRO/CON.....	104
10.3.2	AP Configuration Files.....	105
10.3.2.1	AP resolve	105
10.3.2.2	AP system.conf.....	105
10.3.2.3	AP initswitchcli.....	106
10.3.3	SU Configuration Files.....	106
10.3.3.1	SU resolve	106
10.3.3.2	SU initbridge.....	106
10.3.3.3	SU system.conf	107
10.3.3.4	SU inetr1483.....	107
10.3.4	Troubleshooting	107
10.3.4.1	Can't ping the radio from the terrestrial interface.....	107
10.3.4.2	Can't ping across the wireless link	109
11	Native ATM.....	110
11.1	Static Native ATM	110
11.1.1	AP Configuration Files.....	111
11.1.1.1	AP resolve	111
11.1.1.2	AP system.conf.....	111
11.1.1.3	AP initswitchcli.....	112
11.1.2	SU Configuration Files.....	112
11.1.2.1	SU resolve	112
11.1.2.2	SU system.conf	113
11.1.2.3	SU initswitchcli.....	113
11.1.3	Troubleshooting	113
11.1.3.1	Can't ping the radio from the terrestrial interface.....	113
11.1.3.2	Can't ping the radio across the wireless link.....	115
12	Extender.....	117
12.1	Ethernet Extender.....	117
12.1.1	BHM Configuration Files	118
12.1.1.1	BHM resolve.....	118

12.1.1.2	BHM initbridge	118
12.1.1.3	BHM initr1483	118
12.1.1.4	BHM system.conf	118
12.1.2	BHS Configuration Files	119
12.1.2.1	BHS resolve	119
12.1.2.2	BHS initbridge	119
12.1.2.3	BHS system.conf	119
12.1.2.4	BHS initr1483	119
12.1.3	Troubleshooting	120
12.1.3.1	Can't ping the radio from the terrestrial interface	120
12.1.3.2	Can't ping the radio across the wireless link	120
12.2	ATM Extender	121
12.2.1	BHM Configuration Files	122
12.2.1.1	BHM resolve	122
12.2.1.2	BHM system.conf	122
12.2.1.3	BHM initswitchcli	123
12.2.2	BHS Configuration Files	123
12.2.2.1	BHS resolve	123
12.2.2.2	BHS system.conf	124
12.2.2.3	BHS initswitchcli	124
12.2.3	Troubleshooting	124
12.2.3.1	Can't ping the radio from the terrestrial interface	124
12.2.3.2	Can't ping the radio across the wireless link	126
13	RF Design and Planning	128
13.1	Overview	128
13.2	The U-NII & ISM Channel Plan	128
13.3	Air Interface	128
13.4	Wireless MAC	128
13.4.1	Downstream burst	129
13.4.1.1	Access Point Turnaround Time (ATT)	129
13.4.1.2	Frame Descriptor Header (FDHDR)	129
13.4.1.3	Reservation Grant (RG)	129
13.4.1.4	Downstream Acknowledgement (DACK)	130
13.4.1.5	Downstream Data Cells (DCELL)	130
13.4.1.6	Subscriber Turnaround Time (STT)	130
13.4.1.7	Reservation Request (RR)	130
13.4.1.8	Upstream Acknowledgement (UACK)	130
13.4.1.9	Upstream Cell (UCCELL/UCCELLR)	130
13.5	Delay Compensation	130
13.6	RF Channels spacing and output power	132
13.7	TDD (Time Division Duplex)	132
13.8	AP and SU Specifications	133
13.8.1	AP/SU/Extender Functional Block Diagram	133
13.8.2	Radio Specifications	134
13.8.3	Subscriber Unit Antenna	135
13.8.4	Access Point Antenna	136
13.8.5	Extender Antenna	137
13.9	Topology Types	138
13.10	Interference Types	139
13.10.1	Type 1 Interference	140
13.10.2	Type 2 Interference	140
13.10.3	Type 3 Interference	141
13.10.4	Type 4 Interference	141
13.11	Recommended Channel Plans	142
13.11.1	Six-Sector, Three-Frequency Plan	142
13.11.2	Six-Sector, Six-Frequency Plan	143

- 13.12 Antenna Spacing143**
- 14 SNMP145**
- 15 Rupee146**
 - 15.1 LINUX146**
 - 15.2 DOS146**
 - 15.3 Rupee Option Definitions.....147**
- 16 RTFD (Return To Factory Default).....148**
 - 16.1 RTFD IP Configurations148**
 - 16.2 Recover.....148**
 - 16.3 Procedure to restore the default configuration149**
 - 16.4 Disabling the RTFD Feature.....149**

2 Document Overview

This document covers technical specifications and configuration information for the AB-Access system. It also covers some general troubleshooting steps to resolve issues that may occur while configuring or deploying the AB-Access system. This document should only be used as a reference for the 5.1.6 EMS and 5.1.5 or newer System Software.

3 AB-Access Overview

3.1 Topologies

There are three topologies that are available with the AB-Access units CLIP, 1483 Bridging, and Native ATM. There are several configuration variations within these topologies but all will be referred by these names with an extension.

3.1.1 CLIP (RFC 1577)

CLIP stands for Classical IP and is a routed topology. The AP or SU acts as a standard Layer 3 IP router, which means when data comes into the unit it analyzes the IP header and sends it out one of its interfaces based on the information in the header and its routing tables. It is important to note that only IP traffic can be passed over the units in this configuration.

3.1.2 1483 Bridging (RFC 1483)

1483 Bridging is a Layer 2 bridge, which will pass any valid Ethernet frame regardless of protocol. 1483 is also referred to as MPoA (Multi-protocol over ATM). The basic concept of how the bridge works is simple. It has two tables one for the terrestrial interface and one for the wireless interface. The terrestrial table stores all source MAC address it has learned from the terrestrial interface. It learns the MAC addresses by storing the source MAC address of any packet that has originated from a device on its terrestrial interface. If a packet is received that has a destination MAC address that is already in the table it will be discarded. The reason for this is if the destination MAC address is in the table it must mean that the device with that MAC address is on the terrestrial side of the radio. The wireless table works in the same manor except it learns the source MAC address of packets that have been received from the wireless interface. It is important to note that all broadcast packets will be sent over the link. It is also important to note that the implementation of 1483 bridging that the AB-Access system uses is LLC/SNAP encapsulation and we do not support the VC multiplexing implementation.

3.1.3 Native ATM

Native ATM is a mode where both the AP and the SU act as an ATM switch. In this mode ATM cells are simply passed through the switching layer of the radio at layer 2. It is important to note that the AB-Access radio only supports PVC and not SVC.

3.1.4 PPPoA (RFC 2364)

PPPoA is no longer supported.

4 AB-Access Reference Model

The diagram below is the architectural reference model for this document. Depending upon the required architecture, certain layers of this model may or may not be used.

Please note that both the wireless and terrestrial interfaces have access to all of the

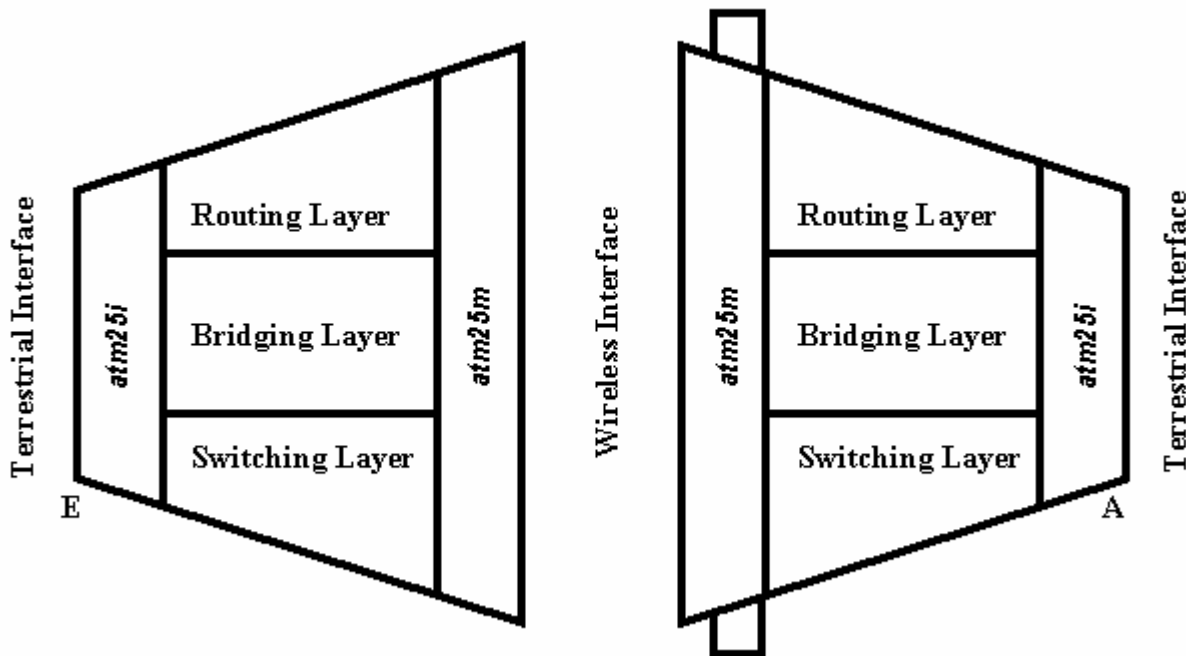

functions of the unit. This is designed to allow the reader to understand where an incoming service is terminating and where its configuration is managed. Management files (on Flashfs) for each layer are as follows:

All: system.conf

Routing Layer: resolve

Bridging Layer: resolve, initbridge, initmr1483 or initr1483

Switching Layer: initswitchcli

An E or A will indicate the Terrestrial interface type below the interface at the corner. As an example, the diagram above shows an SU (on the left) with an Ethernet terrestrial interface and an AP (on the right) with an ATM interface. The Wireless interface is always ATM.

Additional services/clients such as NAT and/or DHCP will be depicted at the appropriate interface.

4.1 Subnetting

Subnetting within the AB-Access radios is done in hexadecimal format. There for it is necessary to know the decimal to hex conversions for commonly used subnets. CIDR notation is also used to define the subnets in all the diagrams, so refer to the chart below for any questions on subnetting.

Decimal Subnet	HEX Subnet	CIDR
0	00	/24
128	80	/25
192	C0	/26
224	E0	/27
240	F0	/28
248	F8	/29
252	FC	/30

4.2 Peak Cell Rate - PCR

The Peak Cell Rate is policing not pacing, there for it will discard all cells received over the limit and not buffer them. This means the cells will have to be retransmitted via an upper layer protocol. To calculate the Peak Cell Rate you simply divide the desired bandwidth by the number of bits in an ATM cell. An ATM cell is 53 bytes consisting of a 5-byte header and a 48-byte payload. In the following example, the PCR for a 1 Megabit circuit is calculated. PCR values are rounded to the nearest integer.

$$1024000 \text{ bps} / (48 \text{ bytes-per-cell} * 8 \text{ bits-per-byte}) = 2667$$

The following table lists PCR values for several, common data rates.

Data Rate	PCR
56 kbps	146
128 kbps	333
256 kbps	667
512 kbps	1333

Data Rate	PCR
1 Mbps	2667
2 Mbps	5333
5 Mbps	13333

4.3 ATM Switch

ATM switches are referenced throughout this document. The ATM switch used for illustration purposes is the FVC Access NGI. The switch used for the troubleshooting screenshots represents FVC software version 5.07. Some of the commands for older FVC switch software are different.

5 Static Configurations

Before one creates a static system you must first know what everything in the configuration files mean. The files listed below are all the configuration files that can be configured on the system.

5.1 resolve

The resolve file stores the IP configuration information such as IP address, netmask, and the routing table.

5.1.1 device

device add *device interface drivers mtu mtusize ipaddress*

device	<i>{atm0 atm1 eth0}</i> This name is used to define a virtual device.
interface	<i>{atm ether}</i> Used to define the physical medium of the device It is important to know that the wireless interface is always ATM and the terrestrial interface can be either ATM or Ethernet.
drivers	<i>{//bun //edd //bridge}</i> <i>//bun</i> = ATM interface <i>//edd</i> = Ethernet interface <i>//bridge</i> = Ethernet interface via bridge (all interactive modes and 1483 bridging mode)
mtusize	<i>maximum transmission unit (max: 1500)</i>
ipaddress	<i>{a.b.c.d dhcp}</i> IP address that will be associated with the device.

Example

The following example shows an ATM device for the terrestrial interface.

```
device add atm0 atm //bun mtu 1500 192.168.2.50
```

5.1.2 nat

nat add device

device	<i>{atm0 atm1 eth0}</i> Corresponds to the device in the device line that you want NAT enabled on. NAT should be enabled on the WAN interface.
--------	--

Example

The following example shows NAT enabled on the atm1 device.

nat add atm1

5.1.3 subnet

subnet add device . networkID subnetmask

device	<i>{atm0.home atm1.home eth0.home bridge.home}</i> Is used to define what device the subnet is being defined for.
networkID	<i>{a.b.c.d}</i> The networkID, which is defined in a decimal format.
subnetmask	<i>{ff:ff:ff:ff}</i> The subnet mask in hexadecimal.

Example

The following example shows a subnet defined for the device that was defined in x.

NOTE: There is a period before the networkID, this is part of the syntax and needs to be included.

subnet add atm0.home . 192.168.2.32 ff:ff:ff:e0

5.1.4 rip accept

rip accept interface version

interface	<i>{device all}</i> This will correspond to the device defined on the device line.
version	<i>{1 2 1 2 none}</i> Defines which version of RIP you want to accept.

Example

The following example shows the Ethernet interface accepting RIP version 1 & 2.

rip accept eth0 1 2

5.1.5 rip send

rip send interface version

interface	<i>{device all}</i> This will correspond to the device defined in device line.
version	<i>{1 2 1 2 none}</i> Defines which version of RIP you want to accept.

Example

The following example shows the wireless ATM interface sending RIP version 2.

rip send atm1 2

5.1.6 rip relay

rip relay version remoteip device timeout

version	<i>{1 2 1 2}</i> Version of RIP to send.
remoteip	<i>{a.b.c.d}</i> Remote IP address to send RIP to.
device	<i>{device}</i> Device that RIP is to be sent from. This will usually be atm1 or atm0.
timeout	<i>{seconds}</i> The number of seconds until connection will timeout. This parameter is optional, if not set the rip relay will not timeout.

Example

The following example shows rip version 2 being sent over the wireless interface.

rip relay 2 192.168.10.3 atm1

5.1.7 route add

route add name network gateway netmask cost

name	Unique name used to identify the route.
network	<i>{a.b.c.d}</i> Network ID of remote network.

gateway	<i>{a.b.c.d}</i> Target IP address for path to remote network.
netmask	<i>{ff:ff:ff:ff}</i> Subnet mask of remote network.
cost	<i>{#}</i> Hop count to destination network, also referred to as metric. Cost is optional, and will be set to 1 if nothing is set. If this is not set correctly and you are running RIP it could overwrite the static route.

Example

The following example shows a default route. A # sign can be used to put comments after the route. In the example it is used to state that it is a manual route.

```
route add default 0.0.0.0 192.168.2.1 00:00:00:00 1 # MAN
```

5.1.8 ipatm lifetime

```
ipatm lifetime seconds
```

seconds	<i>{?-?}</i> The number of seconds an ATM cells can traverse a network before it will timeout, like the TTL of an Ethernet frame.
---------	---

Example

The following example shows the lifetime set to 60 seconds, which is the default.

```
ipatm lifetime 60
```

5.1.9 relay

```
relay interface
```

interface	<i>{all}</i> There are more options for this, but for the purpose of keeping this simple just use “all”. Refer to the CLI document for more options.
-----------	--

Example

The following example shows relay command being used to relay between all devices.

```
relay all
```

5.1.10 ipatm pvc add

```
ipatm pvc add interface port vpi/vci pcr pcr-rx/pcr-tx remoteip ipaddress
```

interface	<i>{atm1 atm0}</i> This defines which device you want to bind the ipatm pvc to.
port	<i>{atm25m atm25i}</i> atm25m = wireless port atm25i = terrestrial port
vpi	<i>{0-7}</i> Currently only VPI 0 is supported on the wireless interface. The terrestrial interface can use any in the range.
vci	<i>{32-65535}</i> Virtual Circuit Identifier
pcr-rx, pcr-tx	<i>{0-70000}</i> Peak Cell Rate, used to define the maximum cells arrival/transmission rate at/from the wireless interface (ATM cells per second). rx = data received from the wireless interface to be sent over the terrestrial interface. tx = data received from the terrestrial interface to be sent over the wireless interface.
ipaddress	<i>{a.b.c.d}</i> The remote IP address of the other device.

Example

The following example is an ipatm pvc for the wireless interface bound to the device atm1. It is using VPI 0 & VCI 768 with a peak cell rate of 60000 and a destination IP address of 192.168.10.3.

```
ipatm pvc atm1 atm25i 0/768 pcr 70000/70000 remoteip 192.168.10.3
```

Old syntax

Note: The following old syntaxes are no longer valid.

```
ipatm pvc atm1 atm25i 0/768 pcr 60000 remoteip 192.168.10.3
```

```
ipatm pvc atm1 768/192.168.10.3/60000 atm25i
```

5.2 system.conf

5.2.1 channel

channel number

number	<p><i>{0-14}</i> This defines the RF channel.</p> <p>0-4 = lower power (indoor only)</p> <p>5-9 = mid power (outdoor)</p> <p>10-16 = high power (outdoor)</p>
--------	---

Note: The channel plans can vary in different countries.

Example

The following example shows a unit transmitting on channel 14, which is a high power channel.

channel 14

5.2.2 antenna

antenna polarization

polarization	<p><i>{vertical horizontal}</i> Defines the antenna.</p>
--------------	--

Example

The following example shows the antenna set to vertical polarization.

antenna vertical

5.2.3 mode

mode operation

operation	<p><i>{static interactive}</i> Defines the mode of operation.</p> <p>static = puts radio in stand alone mode</p> <p>Interactive = puts radio in mode that needs EMS to operate</p>
-----------	--

Example

The following example shows a unit operating in a static mode, which means the unit is in a stand alone mode.

mode static

5.2.4 mid

mid number

number	<i>{0-254}</i> Mobile ID is a unique identifier per radio in a sector. MID 0 is always used for the AP, and can't be used for an SU. MID 255 is reserved and used as the broadcast MID. Also no MIDs can be duplicated in a sector.
--------	--

Example

The following example shows a AP's mid.

mid 0

5.2.5 bid

bid number

number	<i>{0}</i> The bid is currently not used.
--------	---

Example

The following example shows bid of 0. The bid is not used at this time and should just be left to the default of 0.

bid 0

5.2.6 interface

interface type

type	<i>{atm0 eth0}</i> Defines the interface type for the terrestrial interface.
------	--

Example

The following example shows a unit that has an Ethernet interface defined. It is important to know that this is the only setting that makes a unit ATM or Ethernet on the physical layer.

interface eth0

5.2.7 duplex

duplex type

type	<i>{half full}</i> Sets the Ethernet interface to half or full duplex.
------	--

Example

The following example shows a unit's interface set to full duplex.

duplex full

NOTE: If set to full duplex unit must be connected to a switch or router and not a hub. The unit will not auto-negotiate in full duplex, so you must set switch to 10Mb Full Duplex.

5.2.8 backoff

backoff dB

dB	<i>{0-20}</i> Reduces the transmit power and is measured in dB. Backoff should only be used indoors or in rare situations that call for less power to be transmitted from the antenna. Backoff should also be set the same on all units in the sector.
----	--

Example

The following example shows a unit that is not backed off. This is how most of units in the field will be configured.

backoff 0

5.2.9 provider

provider text

text	Text field that can hold up to 24 characters.
------	---

Example

The following example shows the Provider as "abw".

provider abw

5.2.10 key

key code

code	Text field that can hold up to 14 characters. This function is not currently enabled.
-------------	---

Example

The following example shows an authentication key that is default. Units currently ignore this field.

key Axxcelera

5.2.11 mask

mask mask#

mask#	<i>{5 digit hex #}</i> This is only used in an interactive system. It prevents the radio from scanning specific RF channels.
--------------	--

RF Channel Bit Map Table for Creating Mask#

Channel	16	15	14	13	12	11	10	9	8	7	6	5	4	3	2	1	0
Binary Position Value	1	8	4	2	1	8	4	2	1	8	4	2	1	8	4	2	1
Decimal Value	1	15			15			15			15						
Hexadecimal Value	1	f			f			f			f						

Decimal to Hexadecimal Conversion Table

Decimal	0	1	2	3	4	5	6	7	8	9	10	11	12	13	14	15
Hex	0	1	2	3	4	5	6	7	8	9	a	b	c	d	e	f

Example

The following example shows a unit that is masked to not scan channels 0-9 (Binary: 1:1111:1100:0000:0000 = Decimal: 1:15:12:0:0)

mask 1fc00

5.2.12 leds

leds mode

mode	<p><i>{active debug}</i> Defines the interpretation for the LEDs on the wallbox.</p> <p>Active = Upon boot the yellow light will go solid indicating the unit has power. The green light is then a data traffic light and flashes when data is transmitted on the terrestrial interface.</p> <p>Debug = Upon boot the yellow light defines the terrestrial interface, once for Ethernet, twice for ATM. The green light becomes an RF link status light flashing once if the modems have not synchronized and 5 times if they have.</p>
-------------	---

Example

The follow example puts the unit’s wallbox into active mode.

leds active

5.2.13 max_mid

max_mid #

#	<p><i>{1-254}</i> This is only set in the AP and sets the number of interactive SUs that are allowed to register with the AP.</p>
---	---

Example

The following example specifies 32 as the maximum MID supported by the AP and effectively limits the number of SUs to 32.

max_mid 32

5.3 initswitchcli

5.3.1 tp

tp name service pcr

name	<p><i>{name default}</i> Can be assigned a name or the default.</p>
service	<p><i>{UBR CBR ABR VBR}</i> UBR is currently the only service that is supported.</p>

pcr	<i>{0-70000}</i> Peak Cell Rate, used to define the maximum cells arrival/transmission rate at/from the wireless interface (ATM cells per second).
------------	--

Example

TP (traffic parameter) sets the type of service that is desired and peak cell rate. The following example shows the TP default set to Unspecified Bit Rate with a Peak Cell Rate of 2667.

```
tp default UBR 2667
```

NOTE: When setting PCR for a bi-directional PVC the following applies.

atm25i – atm25m = terrestrial – wireless : which is the same as the tx in the ipatm pvc settings.

atm25m – atm25i = wireless – terrestrial : which is the same as the rx in the ipatm pvc settings.

5.3.2 sp

```
sp name buffer stats
```

name	<i>{name default}</i> Can be assigned a name or the default.
buffer	<i>{cells}</i> Number of cells that can be buffered.
stats	<i>{stats}</i> Is optional, but needs to be used for the stats command to work.

Example

SP (switch parameter) sets the size of the buffer in the switchcli and whether or not stats are recorded. The following shows the buffer set to 256 cells and stats recording enabled. This should be the default for all configs using the switchcli.

```
sp default 256 stats
```

N

5.3.3 add

```
add iport ivpi ivci oport ovpi ovci tp sp type epd
```

iport	<i>{atm25i atm25m}</i> In port of uni-directional PVC. atm25i = terrestrial atm25m = wireless
ivpi	<i>{0-7}</i> Currently only VPI 0 is supported on the wireless interface. The terrestrial interface can use any in the range.
ivci	<i>{32-65535}</i> In port VCI.
oport	<i>{atm25i atm25m}</i> Out port of the uni-directional PVC.
ovpi	<i>{0-7}</i> Currently only VPI 0 is supported on the wireless interface. The terrestrial interface can use any in the range.
ovci	<i>{32-65535}</i> Out port VCI.
tp	<i>{name}</i> This is the name of the traffic parameter (previously set) that applies to this PVC mapping.
sp	<i>{name}</i> This is the name of the switch parameter (previously set) that applies to this PVC mapping.
type	<i>{perm soft none}</i> For all static configurations “perm” should be used.
epd	<i>{epd}</i> Early Packet Discard will discard arriving cells when buffering is below 32 cells.

Example

The following example shows a uni-directional PVC mapped from the terrestrial to wireless port.

```
add atm25i 0 100 atm25m 0 256 default default perm epd
```

5.4 initmr1483

Use this file only on APs. The corresponding file for an SU is initr1483.

5.4.1 floodmode

floodmode mode

mode	<i>{0 1}</i> 0 = Flooding of unlearned unicast packets is disabled.
------	--

	1 = Flooding of unlearned unicast packets is enabled.
--	---

Example

The following example configures the mr1483 device to forward all unlearned unicast packets.

floodmode 1

5.4.2 up

up mid vci port pcr-rx pcr-tx

mid	<i>{1-254}</i> MID of the SU that the data will be sent to.
vci	<i>{MID*256}</i> The MID of the SU multiplied by 256.
port	<i>{atm25m}</i> Only the wireless port can be used for this device.
pcr-rx	<i>{0-70000}</i> Peak Cell Rate, used to define the maximum cells passed per second.
pcr-tx	<i>{0-70000}</i> Peak Cell Rate, used to define the maximum cells passed per second.

Example

The following example sets up a mr1483 PVC to an SU with MID 3.

up 3 768 atm25m 70000 70000

5.5 initr1483

Use this file only on SUs. The corresponding file for an AP is initmr1483.

5.5.1 pvc

pvc vpi/vci port pcr-rx pcr-tx

vpi	<i>{0}</i> Only VPI 0 is supported.
vci	<i>{MID*256}</i> The MID of the SU multiplied by 256.
port	<i>{atm25m}</i> Only the wireless port can be used for this device.
pcr-rx	<i>{0-70000}</i> Peak Cell Rate, used to define the maximum cells

	arrival rate from the wireless interface (ATM cells per second).
pcr-tx	<i>{0-70000}</i> Peak Cell Rate, used to define the maximum cells transmission rate at the wireless interface (ATM cells per second).

Example

The following example sets up a r1483 PVC to an AP from an SU with MID 3.

```
pvc 0/768 atm25m 70000 70000
```

5.6 initbridge

5.6.1 spanning

spanning mode

mode	<i>{disable enable}</i> Currently spanning tree is not supported so you must choose the disable option.
------	---

Example

The following example shows spanning tree disabled. Spanning tree is not supported at this time.

```
spanning disable
```

5.6.2 device add

device add device

device	<i>{edd mr1483 r1483}</i> edd = Ethernet interface mr1483 = multi-port 1483 bridge (AP only) r1483 = single-port 1483 bridge (SU, Backhaul Master, Backhaul Slave)
--------	---

Example

The follow example adds the Ethernet interface to the bridge.

```
device add edd
```

5.7 dhcpd.conf

The dhcpd.conf file follows the same syntax as a Linux or UNIX dhcpd.conf file.

5.7.1 subnet

subnet networkid **netmask** subnet

networkid	<i>{a.b.c.d}</i> The network ID for the leased addresses.
subnet	<i>{a.b.c.d}</i> The subnet for the leased addresses.

Example

The following example sets the subnet for the 10.10.10.0 network with a class C netmask.

subnet 10.10.10.0 netmask 255.255.255.0

5.7.2 range

range startip stopip

startip	<i>{a.b.c.d}</i> First IP address in the range that will be leased out to clients.
stopip	<i>{a.b.c.d}</i> Last IP address in the range that will be leased out to clients.

Example

The following example shows the range of IP that the DHCP server can lease out to clients.

range 10.10.10.10 10.10.10.20

5.7.3 option routers

option routers gateway

gateway	<i>{a.b.c.d}</i> Gateway IP for the computers leasing addresses.
---------	--

Example

The following example sets the default route (gateway) address for all clients that lease an address from the server.

option routers 10.10.10.1

5.7.4 max-lease-time

max-lease-time seconds

seconds	<i>{0-86400}</i> Time in seconds that a client can hold a leased address from the DHCP server. A setting of 0 seconds will make the lease never timeout.
---------	--

Example

The following example sets the lease time to 24 hours (=24x60x60).

max-lease-time 86400

5.7.5 option domain-name

option domain-name dnsname

dnsname	<i>{name}</i> Name of the DNS Server.
---------	---------------------------------------

Example

The following example sets the DNS suffixes that the clients will use.

option domain-name www.dns.com

5.7.6 option domain-name-servers

option domain-name-servers dnsip

dnsip	<i>{a.b.c.d}</i> IP address of the DNS Server.
-------	--

Example

The following example sets the DNS server that all the clients will use.

option domain-name-servers 192.168.1.254

5.8 snmpinit

5.8.1 access write

access write password

password	<i>{password}</i> Sets the password for the unit.
----------	---

Example

The following example sets the password to “atmos”.

```
access write atmos
```

NOTE: AB-Access only supports write access and does not support read access.

6 CLIP_T

The CLIP_T configuration is when both the AP and SU are setup as routers. This means that when data arrives on any interface it is analyzed at layer 3 and based on the destination IP address is forwarded out the proper interface.

6.1 Interactive CLIP_T Eth AP

All assumptions for troubleshooting Interactive CLIP_T Eth AP will be based on the following diagram.

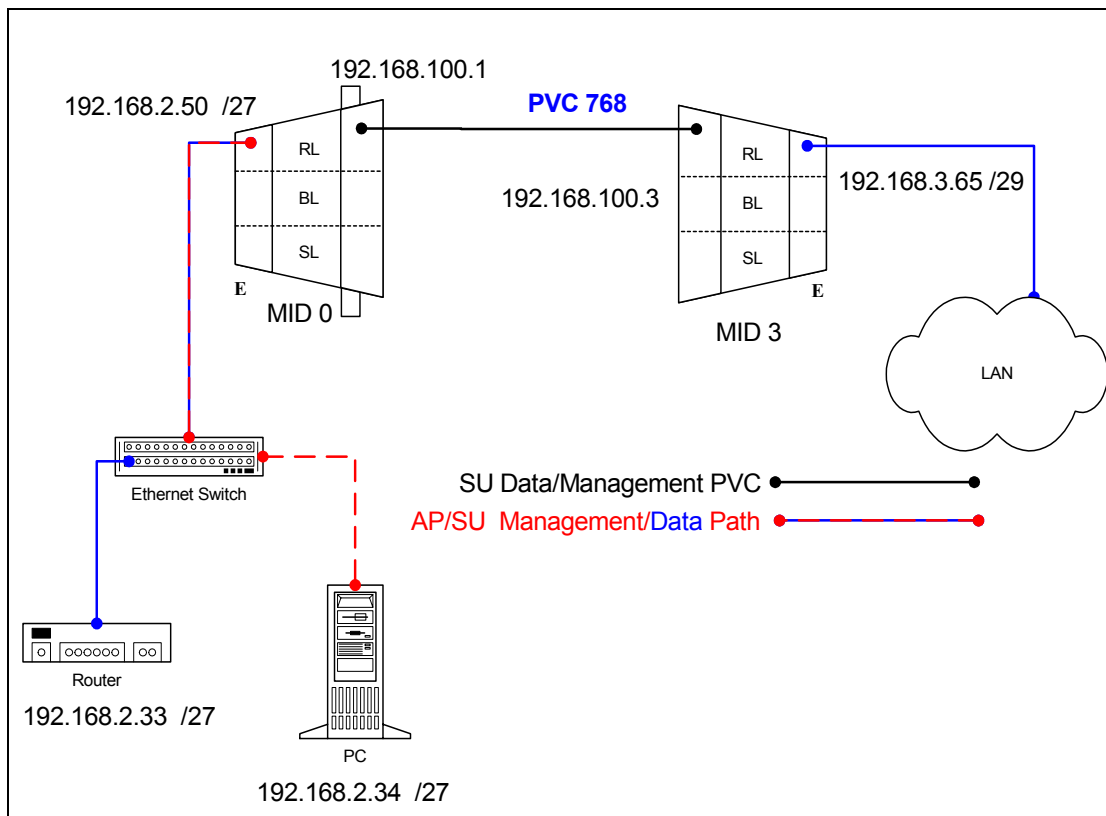

6.1.1 Adding AP and SU to EMS

Dialogue boxes showing the information needed to add an AP or SU are shown below.

New Access Point

Config | Alarm

Name: CLIP_T AP

Configuration: CLIP terminated (RFC 1577)

Interface: Ethernet

General

MAC address: 00:c0:69:0c:52:2f Unit type: U-NII

Location: Lab Alarm profile: (default)

Base Station: Lab BS Availability state: Available

Telnet password: *****

IP

Management address: 192.168.2.50

Radio

Channel: 0 Direction: 180

Polarization: Horizontal

OK Apply Cancel

New Subscriber Unit

Config | Alarm

Name: CLIP_T SU

Configuration: CLIP terminated (RFC 1577)

Interface: Ethernet

General

MAC address: 00:c0:69:0b:58:7f Alarm profile: (default)

Location: Lab Availability state: Available

Unit type: U-NII Authentication key: axx

Telnet password: ***** Assigned Access Point: Dynamic

IP

Management address: 192.168.3.65

Management netmask: 255.255.255.248

ATM

Upstream PCR: 70000 Cells/s

Downstream PCR: 70000 Cells/s

OK Apply Cancel

6.1.2 Troubleshooting

6.1.2.1 AP Object

If the AP will not register make sure all the fields in the EMS database are correctly filled in. Here are a few important points that should be kept in mind if the AP doesn't register.

1. See if you can ping the unit. The default configuration is to have the AP receive a DHCP address from the CS. If it has not received it you will not be able to ping it. So if you are unable to ping the AP you should check and see that the dhcpd.conf file is setup properly. Notice that in the example AP1 has a fixed address set, each AP must be given the same address every

time it leases an address. It is important to be aware that by default most routers will not pass DHCP request unless they are specifically configured to do so.

```
#eth0
subnet 192.168.2.0 netmask 255.255.255.224 {
    range 192.168.2.34 192.168.2.50;
    option routers 192.168.2.33;
}

host AP1 {
    hardware ethernet 0:c0:69:0c:52:2f;
    fixed-address 192.168.2.50;
}
```

For various reasons it may be desired to not use DHCP to give an AP an address. In this case the IP address can be statically assigned to the unit. To do this you will need to create a resolve file that looks identical to the CLIP_T static resolve file described in the section for Static 1483_T.

2. Make sure the MAC address is correct. Without the correct MAC address the AP can not register. You can verify this by tailing the adapcs.log file. In this example an SU with the indicated MAC address is trying to register and is not found in the database. Either the SU was not added to the EMS or was entered with the wrong MAC address.

```
[root@cs1 /root]# tail -f /var/log/adapcs.log
```

```
CS[12399.8192](16Dec 21:33:39.524 ): Protocol: 00 00 00 00 01 00 02 00 00 14 00 01 00 c0 69 0c 52 2f 77 94
CS[12399.8192](16Dec 21:33:39.524 ): DynAccessPointImpl (CLIP_T AP): handleEstablishConnection (AP 00c0690c522f)
CS[12399.8192](16Dec 21:33:39.524 ): DynAccessPointImpl (CLIP_T AP): Received ESTABLISH_CONNECTION message
from unknown AP ap_02 1216_135100016_111
```

3. If the CS is on a different network, than the default route in the AP must be correct.

6.1.2.2 SU Object

If the SU will not register make sure all the fields in the EMS database are filled in properly. Here are a few important points that should be kept in mind if the SU doesn't register. Many different things can cause the SU not to register so after verifying all of these points and it still doesn't register the next step will be to troubleshoot the RF link. See RF troubleshooting document.

1. Make sure the MAC address is correct. Without the correct MAC address the AP can not register. You can verify this by tailing the adapcs.log file. In this example an SU with this MAC address is trying to register and is not found in the database, which means when you created the object it had the wrong MAC address.

```
[root@cs1 /root]# tail -f /var/log/adapcs.log
CS[12801.8192](16Dec 21:39:20.034 ): Protocol: 00 00 00 00 01 00 00 05 00 14 00 04 00 c0 69 0b 58 7f b5 10
CS[12801.8192](16Dec 21:39:20.034 ): RegistrarProtocol: SU 00c0690b587f is already registering
CS[12801.8192](16Dec 21:39:20.555 ): EMSProtocol: received message REGMSG_REGISTER_SU for CS
CS[12801.8192](16Dec 21:39:20.555 ): Protocol: message contents (20 bytes)
```

2. Make sure the default route is correct if the SU is on a different network than the Control Server.

3. Verify that the SU has been upgraded to the CLIP_T interactive configuration.

6.2 Static CLIP_T Eth AP

All assumptions for troubleshooting Static CLIP_T Eth AP will be based on the following diagram.

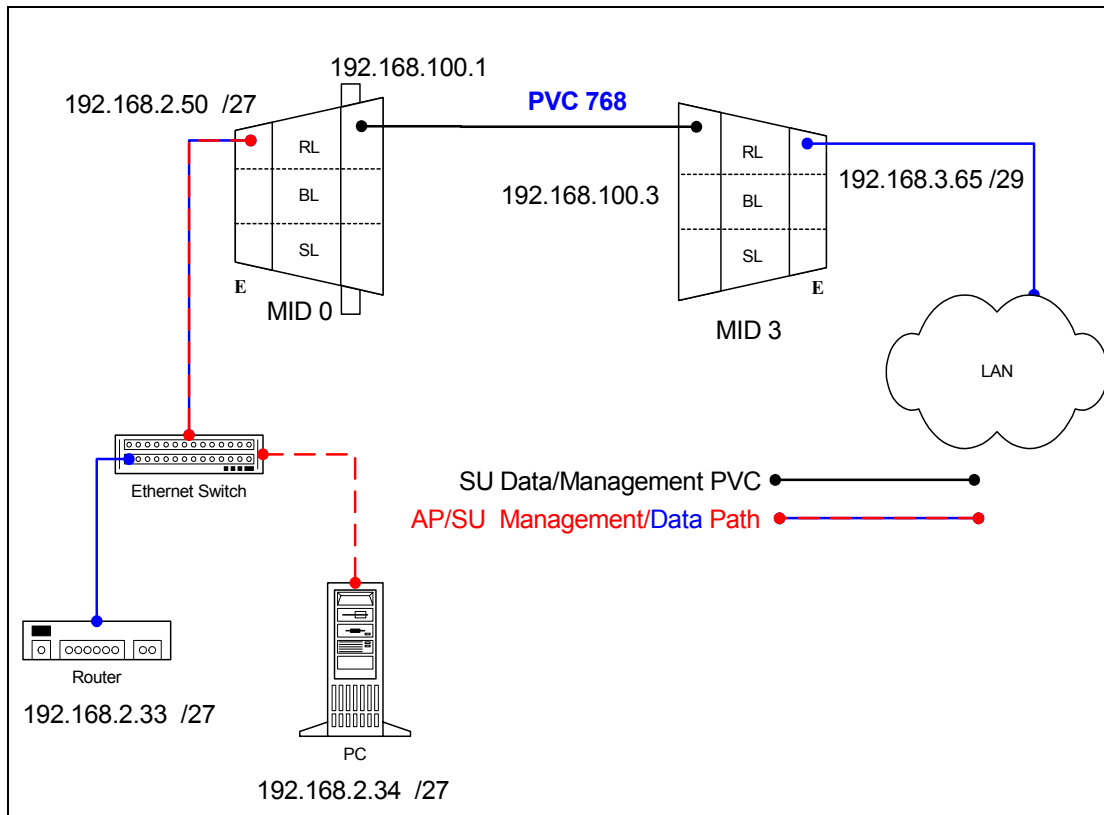

6.2.1 AP Configuration Files

6.2.1.1 AP resolve

```
device add eth0 ether //edd mtu 1500 192.168.2.50
device add atm1 atm //bun mtu 1500 192.168.100.1

subnet add eth0.home . 192.168.2.32 ff:ff:ff:e0
subnet add atm1.home . 192.168.100.0 ff:ff:ff:00

rip send all none
rip accept all none

route add default 0.0.0.0 192.168.2.33 00:00:00:00 1 # MAN
route add su1 192.168.3.64 192.168.100.3 ff:ff:ff:f8 1 # MAN

relay all

ipatm pvc lifetime 60

ipatm pvc atm1 atm25m 0/768 pcr 70000/70000 remoteip 192.168.100.3
```

6.2.1.2 AP system.conf

```
channel 0
antenna horizontal
mode static
mid 0
bid 0
interface eth0
duplex half
backoff 0
provider abw
key Axxcelera
mask 1ffff
leds active
max_mid 254
```

6.2.2 SU Configuration Files

6.2.2.1 SU resolve

```
device add eth0 ether //edd mtu 1500 192.168.3.65
device add atm1 atm //bun mtu 1500 192.168.100.3

subnet add eth0.home . 192.168.3.64 ff:ff:ff:f8
subnet add atm1.home . 192.168.100.0 ff:ff:ff:00

rip send all none
rip accept all none

route add default 0.0.0.0 192.168.100.1 00:00:00:00 1 # MAN

relay all

ipatm lifetime 60

ipatm pvc atm1 atm25m 0/768 pcr 70000/70000 remoteip 192.168.100.1
```

6.2.2.2 SU system.conf

```
channel 0
antenna horizontal
mode static
mid 3
bid 0
interface eth0
duplex half
backoff 0
provider abw
key Axxcelera
mask 1fff
leds active
```

6.2.3 Troubleshooting

6.2.3.1 Can't ping the radio from the terrestrial interface

1. Check all physical connections. The radio is a network device, which means if you connect it to a PC (NIC) you will use a straight-through cable. To connect the radio to a network device (hub, switch, router) use an Ethernet cross-over cable (1-3, 2-6). It is also important to check that the cable is punched down correctly in the wall box and that the cable is terminated correctly at the radio. The termination at the radio uses 568B (wo,o,wg,bl,wbl,g,wbr,br).

2. Make sure the computer you are pinging from is on the same network as the AP. If you are on a different network than the radio make sure you have the proper routes in the radio and the computer you are trying to ping from.

6.2.3.2 Can't ping across the wireless link

There are numerous reason why you couldn't ping across the wireless link. After following these troubleshooting steps and you still can't ping across the wireless link refer to the RF troubleshooting document.

1. Check that SU has the proper MID.

```
192.168.3.65 hmm> system mid
MID 3
```

2. Check the "ipatm pvc" is correct in relation to the MID and remoteip

AP

```
192.168.2.50 ip> ipatm pvc
ipatm pvc atm1 atm25m 0/768 pcr 70000/70000 remoteip 192.168.100.3
```

SU

```
192.168.3.65 ip> ipatm pvc
ipatm pvc atm1 atm25m 0/768 pcr 70000/70000 remoteip 192.168.100.1
```

3. Check the default route in the SU.

```
192.168.3.65 ip> route
route add default 0.0.0.0 192.168.100.1 00:00:00:00 1 # MAN via atm1
```

4. Check that there is a route in the AP that points to the SU's terrestrial network.

```
192.168.2.50 ip> route
route add su1 192.168.3.64 192.168.100.3 ff:ff:ff:f8 1 # MAN via atm1
route add default 0.0.0.0 192.168.2.33 00:00:00:00 1 # MAN via eth0
```

6.3 Static CLIP_T ATM AP

All assumptions for troubleshooting Static CLIP_T ATM AP will be based on the following diagram.

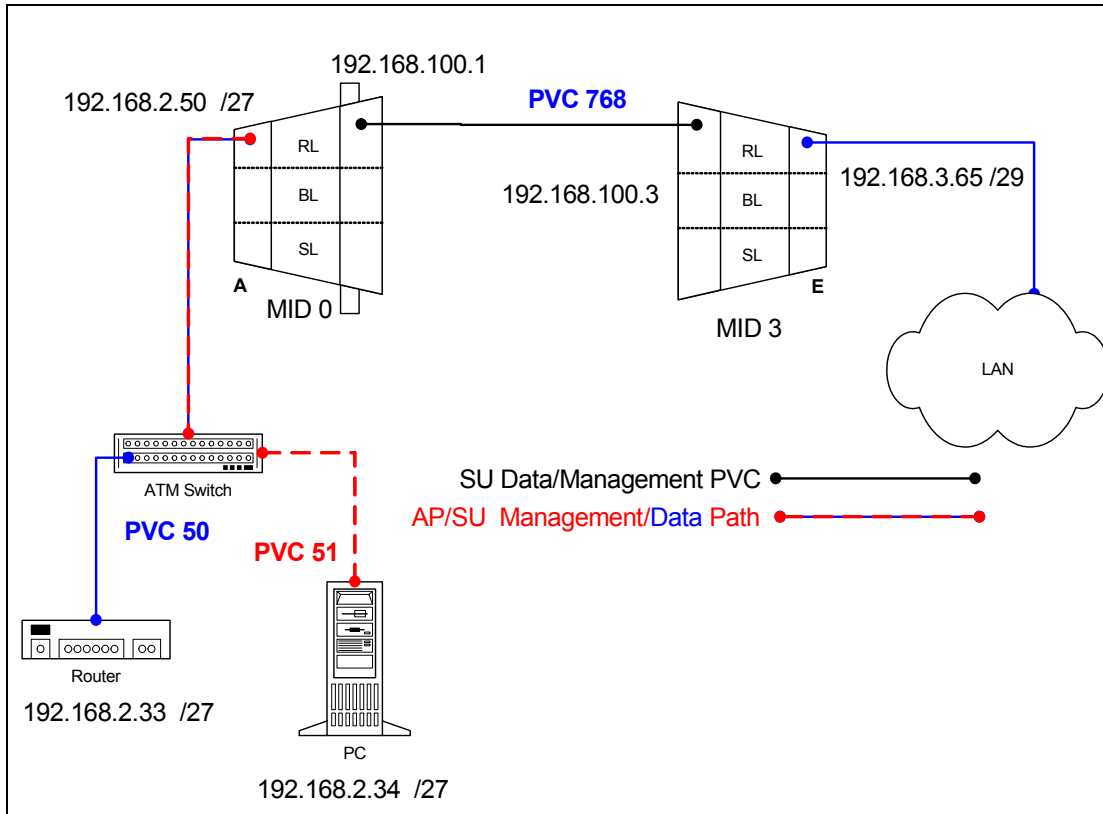

6.3.1 AP Configuration Files

6.3.1.1 AP resolve

```
device add atm0 atm //bun mtu 1500 192.168.2.50
device add atm1 atm //bun mtu 1500 192.168.100.1

subnet add atm0.home . 192.168.2.32 ff:ff:ff:e0
subnet add atm1.home . 192.168.100.0 ff:ff:ff:00

rip send all none
rip accept all none

route add default 0.0.0.0 192.168.2.33 00:00:00:00 1 # MAN
route add su1 192.168.3.64 192.168.100.3 ff:ff:ff:f8 1 # MAN

relay all

ipatm pvc lifetime 60

ipatm pvc atm0 atm25i 0/50 pcr 70000/70000 remoteip 192.168.2.33
ipatm pvc atm0 atm25i 0/51 pcr 70000/70000 remoteip 192.168.2.34
ipatm pvc atm1 atm25m 0/768 pcr 70000/70000 remoteip 192.168.100.3
```

6.3.1.2 AP system.conf

```
channel 0
antenna horizontal
mode static
mid 0
bid 0
interface atm0
duplex half
backoff 0
provider abw
key Axxcelera
mask 1fff
leds active
max_mid 254
```

6.3.2 SU Configuration Files

6.3.2.1 SU resolve

```
device add eth0 ether //edd mtu 1500 192.168.3.65
device add atm1 atm //bun mtu 1500 192.168.100.3

subnet add eth0.home . 192.168.3.64 ff:ff:ff:f8
subnet add atm1.home . 192.168.100.0 ff:ff:ff:00

rip send all none
rip accept all none

route add default 0.0.0.0 192.168.100.1 00:00:00:00 1 # MAN

relay all

ipatm lifetime 60

ipatm pvc atm1 atm25m 0/768 pcr 70000/70000 remoteip 192.168.100.1
```

6.3.2.2 SU system.conf

```
channel 0
antenna horizontal
mode static
mid 3
bid 0
interface eth0
duplex half
backoff 0
provider abw
key Axxcelera
mask 1fff
leds active
```

6.3.3 Troubleshooting

6.3.3.1 Can't ping the radio from the terrestrial interface

AP

1. Check all physical connections. It is a straight cable from the CS to the Switch, and a rollover twist from the wall box to the switch (1-7,2-8).

2. Check to see if your atmarp entries are in the ARP table on the CS. (./atmarp if you are already in the /usr/local/sbin directory)

- Add an atmarp entry

```
root@cs1 11:11:14 (4) [~] # atmarp -s 192.168.2.50 0.0.34
```

- View an atmarp table

```
root@cs1 11:12:52 (5) [~] # atmarp -a
---- If 0 (192.168.2.1, netmask 255.255.255.0) ----
Default QOS: ubr,aal5:max_sdu=9188
IP 192.168.2.50, state VALID, addr <none>, flags 0x4<PERM> 0.0.34
---- Unknown incoming connections ----
---- Incoming unidirectional connections ----
---- End of dump ----
```

- Delete an atmarp entry

```
root@cs1 11:13:42 (6) [~] # atmarp -d 192.168.2.50
```

3. Check route on CS, by typing route at the Command line.

- Add a route

```
root@cs1 11:17:19 (8) [~] # route add -net 192.168.100.0 netmask 255.255.255.0 gw 192.168.2.50
```

- View the routing table

```

root@cs1 11:18:51 (9) [-] # route
Kernel IP routing table
Destination Gateway Genmask Flags Metric Ref Use Iface
10.9.144.1 * 255.255.255.255 UH 0 0 0 eth0
192.168.100.0 192.168.2.50 255.255.255.0 UG 0 0 0 atm0
192.168.2.0 * 255.255.255.0 U 0 0 0 atm0
10.9.144.0 * 255.255.255.0 U 0 0 0 eth0
127.0.0.0 * 255.0.0.0 U 0 0 0 lo

```

- Delete a route

```

root@cs1 11:20:26 (10) [-] # route del -net 192.168.100.0 netmask 255.255.255.0

```

4. Check the Switch for the correct PVC's.

- Log into the ATM switch and check that the PVCs are mapped correctly. The following commands are for an FVC switch.

- Add a PVC

```

ADMIN Access_NGI>set pvc add 101 0 34 be 102 0 34 be

```

```

Adding PVC i=101/0/34 o=102/0/34 to switch fabric
Updating FLASH memory. Please wait ... Done.

```

- Show the PVCs mapped in the switch

```

ADMIN Access_NGI>show pvc list id 0
-----
PVC ID IPort IVPI IVCI BW OPort OVPI OVCI BW
-----
1 101 0 34 0 102 0 34 0

```

- Delete a PVC

```

ADMIN Access_NGI>set pvc del 1

```

SU

1. Check all physical connections. The radio is a network device, which means if you connect it to a PC (NIC) you will use a straight cable. If you connect the radio to a network device (hub, switch, router) you will use a Ethernet cross-over cable(1-3, 2-6). It is also important to check that the cable is punched down correctly in the wall box and the cable is

terminated correctly at the radio. The termination at the radio uses 568B (wo,o,wg,bl,wbl,g,wbr,br).

2. Make sure the computer you are pinging from is on the same network as the AP. If you are on a different network than the radio make sure you have the proper routes in the radio and the computer you are trying to ping from.

6.3.3.2 Can't ping across the wireless link

There are numerous reasons why you couldn't ping across the wireless link. After following these troubleshooting steps and you still can't ping across the wireless link refer to the RF troubleshooting document.

1. Check that SU has the proper MID.

```
192.168.3.10 hmm> system mid
MID 3
```

2. Check the ipatm pvc is correct in relation to the MID and remoteip

AP

```
192.168.2.50 ip> ipatm pvc
ipatm pvc atm1 atm25m 0/768 pcr 70000/70000 remoteip 192.168.100.3
```

SU

```
192.168.3.65 ip> ipatm pvc
ipatm pvc atm1 atm25m 0/768 pcr 70000/70000 remoteip 192.168.100.1
```

3. Check the default route in the SU.

```
192.168.3.65 ip> route
route add default 0.0.0.0 192.168.100.1 00:00:00:00 1 # MAN via atm1
```

4. Check that there is a route in the AP that points to the SU's terrestrial network.

```
192.168.2.50 ip> route
route add su1 192.168.3.64 192.168.100.3 ff:ff:f8 1 # MAN via atm1
route add default 0.0.0.0 192.168.2.34 00:00:00:00 1 # MAN via atm0
```

6.4 Hybrid CLIP_T Eth AP

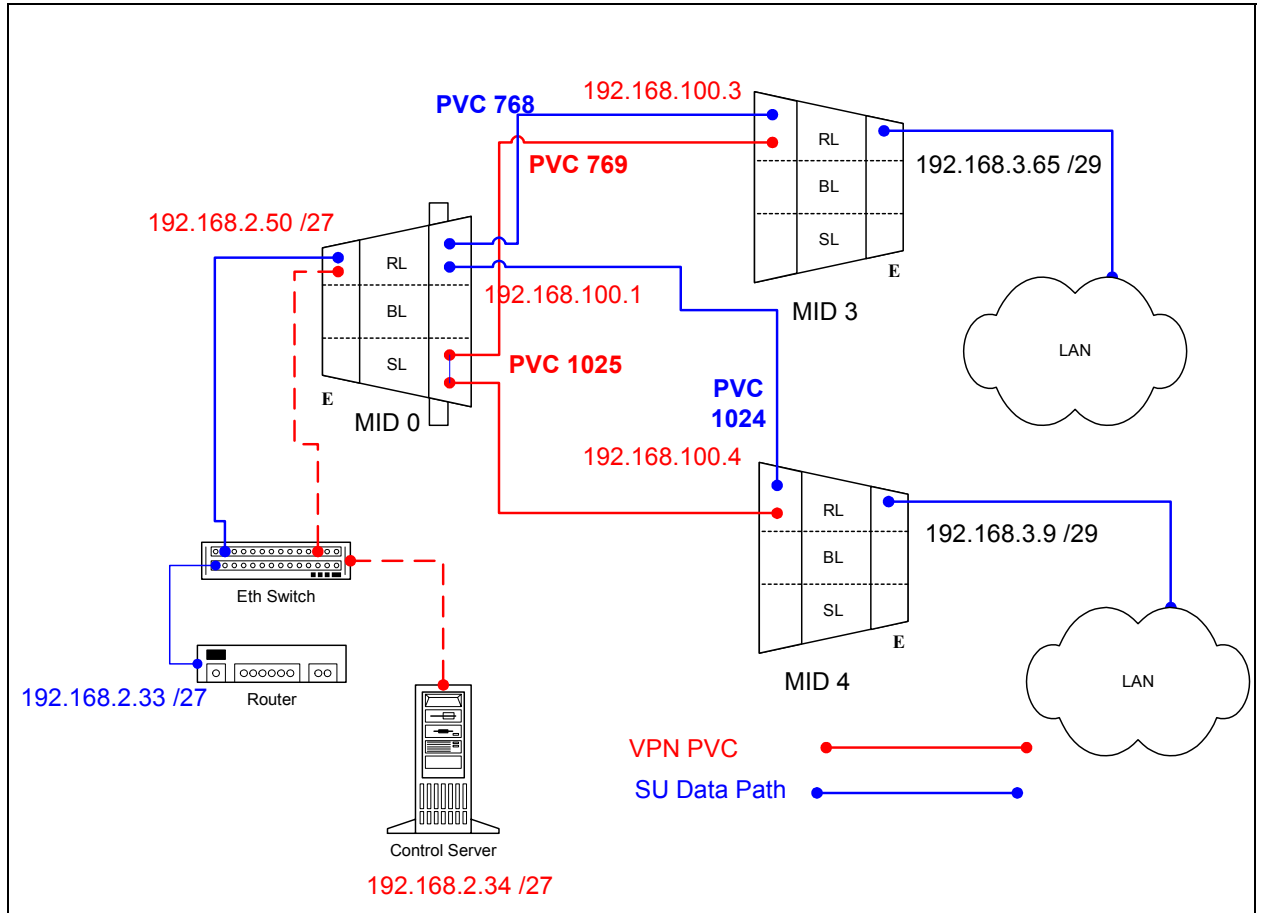

6.4.1 AP Configuration Files

6.4.1.1 AP resolve

```
device add eth0 ether //edd mtu 1500 192.168.2.50
device add atm1 atm //bun mtu 1500 192.168.100.1

subnet add eth0.home . 192.168.2.32 ff:ff:ff:e0
subnet add atm1.home . 192.168.100.0 ff:ff:ff:00

rip send all none
rip accept all none

route add default 0.0.0.0 192.168.2.33 00:00:00:00 1 # MAN
route add su1 192.168.3.64 192.168.100.3 ff:ff:ff:f8 1 # MAN
route add su2 192.168.3.8 192.168.100.4 ff:ff:ff:f8 1 # MAN

relay all

ipatm pvc lifetime 60

ipatm pvc atm1 atm25m 0/768 pcr 70000/70000 remoteip 192.168.100.3
ipatm pvc atm1 atm25m 0/1024 pcr 70000/70000 remoteip 192.168.100.4
```

6.4.1.2 AP system.conf

```
channel 0
antenna horizontal
mode static
mid 0
bid 0
interface eth0
duplex half
backoff 0
provider abw
key Axxcelera
mask 1ffff
leds active
max_mid 254
```

6.4.1.3 AP Switchcli

```
tp default UBR 2667
sp default 256 stats
add atm25m 0 769 atm25m 0 1025 default default perm epd
add atm25m 0 1025 atm25m 0 769 default default perm epd
```

6.4.2 SU1 Configuration Files

6.4.2.1 SU1 resolve

```
device add eth0 ether //edd mtu 1500 192.168.3.65
device add atm1 atm //bun mtu 1500 192.168.100.3

subnet add eth0.home . 192.168.3.64 ff:ff:ff:f8
subnet add atm1.home . 192.168.100.0 ff:ff:ff:00

rip send all none
rip accept all none

route add default 0.0.0.0 192.168.100.1 00:00:00:00 1 # MAN
route add su2 192.168.3.8 192.168.100.4 ff:ff:ff:f8 1 # MAN

relay all

ipatm lifetime 60

ipatm pvc atm1 atm25m 0/768 pcr 70000/70000 remoteip 192.168.100.1
ipatm pvc atm1 atm25m 0/769 pcr 70000/70000 remoteip 192.168.100.4
```

6.4.2.2 SU1 system.conf

```
channel 0
antenna horizontal
mode static
mid 3
bid 0
interface eth0
duplex half
backoff 0
provider abw
key Axxcelera
mask 1ffff
leds active
```

6.4.3 SU2 Configuration Files

6.4.3.1 SU2 resolve

```
device add eth0 ether //edd mtu 1500 192.168.3.9
device add atm1 atm //bun mtu 1500 192.168.100.4

subnet add eth0.home . 192.168.3.8 ff:ff:ff:f8
subnet add atm1.home . 192.168.100.0 ff:ff:ff:00

rip send all none
rip accept all none

route add default 0.0.0.0 192.168.100.1 00:00:00:00 1 # MAN
route add su1 192.168.3.64 192.168.100.3 ff:ff:ff:f8 1 # MAN

relay all

ipatm lifetime 60

ipatm pvc atm1 atm25m 0/1024 pcr 70000/70000 remoteip 192.168.100.1
ipatm pvc atm1 atm25m 0/1025 pcr 70000/70000 remoteip 192.168.100.3
```

6.4.3.2 SU2 system.conf

```
channel 0
antenna horizontal
mode static
mid 4
bid 0
interface eth0
duplex half
backoff 0
provider abw
key Axxcelera
mask 1ffff
leds active
```

6.4.4 Troubleshooting

6.4.4.1 Can't ping the radio from the terrestrial interface

1. Check all physical connections. The radio is a network device, which means if you connect it to a PC (NIC) you will use a straight-through cable. To connect the radio to a network device (hub, switch, router) use an Ethernet cross-over cable (1-3, 2-6). It is also important to check that the cable is punched down correctly in the wall box and that the cable is terminated correctly at the radio. The termination at the radio uses 568B (wo,o,wg,bl,wbl,g,wbr,br).

2. Make sure the computer you are pinging from is on the same network as the AP. If you are on a different network than the radio make sure you have the proper routes in the radio and the computer you are trying to ping from.

6.4.4.2 Can't ping across the wireless link

There are numerous reason why you couldn't ping across the wireless link. After following these troubleshooting steps and you still can't ping across the wireless link refer to the RF troubleshooting document.

1. Check that SU has the proper MID.
192.168.3.65 hmm> system mid
MID 3
2. Check the "ipatm pvc" is correct in relation to the MID and remoteip

AP

```
192.168.2.50 ip> ipatm pvc  
ipatm pvc atm1 atm25m 0/768 pcr 70000/70000 remoteip 192.168.100.3
```

SU

```
192.168.3.65 ip> ipatm pvc  
ipatm pvc atm1 atm25m 0/768 pcr 70000/70000 remoteip 192.168.100.1
```

3. Check the default route in the SU.

```
192.168.3.65 ip> route  
route add default 0.0.0.0 192.168.100.1 00:00:00:00 1 # MAN via atm1
```

4. Check that there is a route in the AP that points to the SU's terrestrial network.

```
192.168.2.50 ip> route  
route add su1 192.168.3.64 192.168.100.3 ff:ff:ff:f8 1 # MAN via atm1  
route add default 0.0.0.0 192.168.2.33 00:00:00:00 1 # MAN via eth0
```

7 CLIP_S

The CLIP_S configuration is when the AP acts as an ATM switch and the SU acts as a router. This means that the AP will pass ATM cells at layer 2, and the SU will act as a router analyzing all data at layer 3 and based upon destination IP address forward the data out the proper interface.

In static mode you can configure the management traffic in either routed or a switched configuration. Each section describes the pros and cons of each configuration so you can decide which is best for your network.

7.1 CLIP_S Interactive

All assumptions for troubleshooting CLIP_S are based on the following diagram.

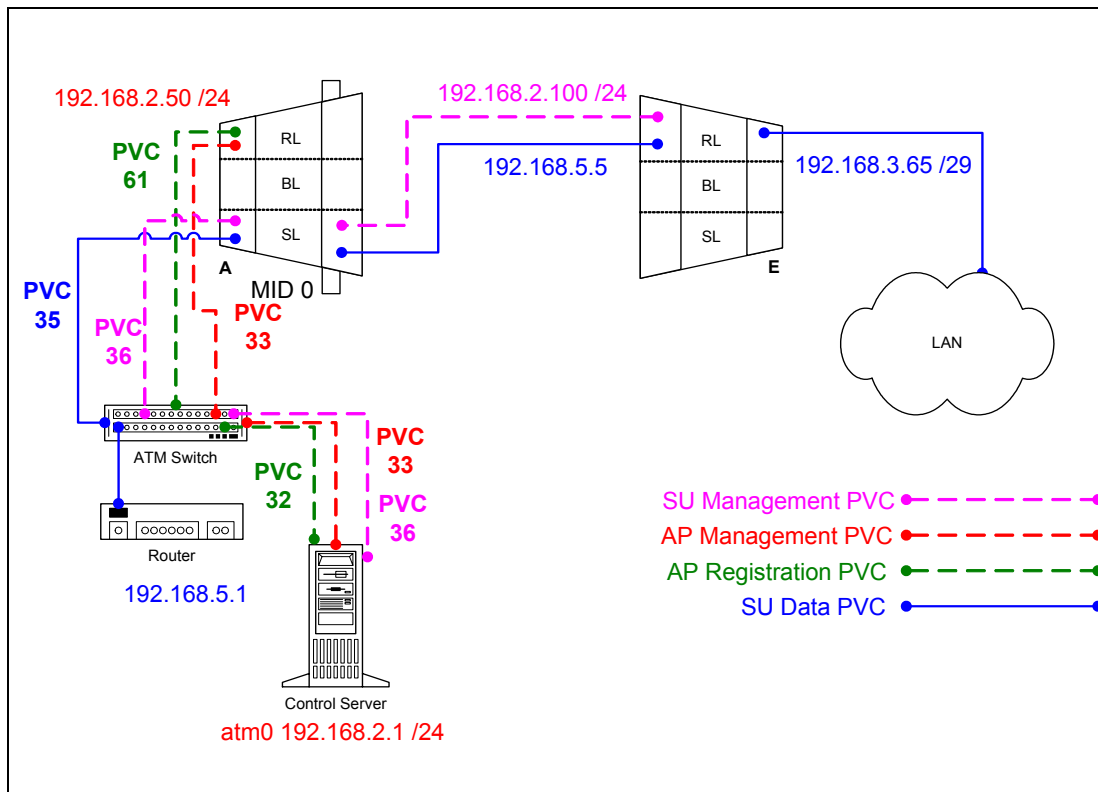

7.1.1 Adding AP and SU to EMS

Dialogue boxes showing the information needed to add an AP or SU are shown below.

New Access Point

Config | Alarm

Name: CLIP_S AP

Configuration: CLIP switched (RFC 1577)

Interface: ATM

General

MAC address: 00:c0:69:0c:52:2f Unit type: U-NII

Location: LAB Alarm profile: (default)

Base Station: Lab BS Availability state: Available

Telnet password: *****

IP

Management address: 192.168.2.50

Management netmask: 255.255.255.0

Radio

Channel: 0 Direction: 180

Polarization: Horizontal

ATM

Management VC at CS: 0.33 Management VC at AS: 0.33

Registration VC at CS: 0.32 Registration VC at AS: 0.32

AS port: 101

OK Apply Cancel

New Subscriber Unit

Config | Alarm

Name: CLIP_S SU

Configuration: CLIP switched (RFC 1577)

Interface: Ethernet

General

MAC address: 00:c0:69:0b:58:7f Alarm profile: (default)

Location: lab Availability state: Available

Unit type: U-NII Authentication key: axx

Telnet password: ***** Assigned Access Point: Dynamic

IP

Management address: 192.168.2.100 Data target: 192.168.5.1

Management netmask: 255.255.255.0 Wired address: 192.168.3.65

Data address: 192.168.5.5 Wired netmask: 255.255.255.248

Data netmask: 255.255.255.0

ATM

Data VC at AS: 0.35 Upstream PCR: 70000 Cells/s

Management VC at AS: 0.36 Downstream PCR: 70000 Cells/s

Management VC at CS: 0.36

OK Apply Cancel

7.1.2 Troubleshooting

7.1.2.1 AP Object

If the AP will not register make sure all the fields in the EMS database are correctly filled in. Here are a few important points that should be kept in mind if the AP doesn't register.

1. Make sure the MAC address is correct. Without the correct MAC address the AP can not register. You can verify what MAC address the AP is attempting to register with by tailing the adapcs.log file. In the following example an AP is trying to register and is not found in the database, which means when you created the object it had the wrong MAC address.

```
[root@cs1 /root]# tail -f /var/log/adapcs.log
CS[5025.8192](16Dec 12:36:03.027 ): AtmAccessPointImpl: Unknown ATM AP 00c0690c522f trying to register
```

2. The management address must be on the same subnet as the atm0 interface on the Control Server.

3. Check that the PVCs are mapped correctly in the switch. Since the problem is with the AP registering, pay close attention to how the registration PVC (61) and management PVC are mapped.

```
ADMIN Access_NGI>show pvc list id 0
ADMIN Access_NGI>
```

PVC ID	IPort	IVPI	IVCI	BW	OPort	OVPI	OVCI	BW
1	101	0	32	0	102	0	61	0
2	101	0	33	0	102	0	33	0

4. The “AS Port” has to be filled in with the proper port if you have chosen to manage the anchor switch with the EMS (selected when creating the Control Server).

5. Make sure the Control Server has the created the proper atmarp entries in it. There should be an atmarp entry for every management address.

- Lists atmarp entries

```
[root@cs1 /root]# atmarp -a
---- If 0 (192.168.2.1, netmask 255.255.255.0) ----
Default QOS: ubr,aal5:max_sdu=9188
IP 192.168.2.50, state VALID, addr <none>, flags 0x4<PERM> 0.0.33
---- Unknown incoming connections ----
---- Incoming unidirectional connections ----
---- End of dump ----
```

7.1.2.2 SU Object

If the SU will not register make sure all the fields in the EMS database are filled in properly. Here are a few important points that should be kept in mind if the SU doesn't register. Many different things can cause the SU not to register so after verifying all of these points and it still doesn't register the next step will be to troubleshoot the RF link. See RF troubleshooting document.

1. Make sure the MAC address is correct. Without the correct MAC address the SU can not register. You can verify this by tailing the adapcs.log file. In this example an SU with this MAC address is trying to register and is not found in the database, which means when you created the object it had the wrong MAC address.

```
[root@cs1 /root]# tail -f /var/log/adapcs.log
CS[5494.8192](16Dec 12:48:34.926 ): Protocol: 00 00 00 00 01 00 00 01 00 14 00 04 00 c0 69 0b 58 7f b5 10
CS[5494.8192](16Dec 12:48:34.926 ): RegistrarProtocol: Registering SU 00c0690b587f (MID 1)
CS[5494.8192](16Dec 12:48:34.926 ): DynAccessPointImpl (CLIP_S AP): handleRegisterSU (SU 00c0690b587f)
CS[5494.8192](16Dec 12:48:34.926 ): DynAccessPointImpl (CLIP_S AP): no key - fetch details from EMSAgent
CS[5494.8192](16Dec 12:48:34.930 ): DynAccessPointImpl: CORBA::BAD_PARAM exception thrown (minor code=0)
CS[5494.8192](16Dec 12:48:34.930 ): DynAccessPointImpl: An SU is trying to register but I can't talk to an EMSAgent
CS[5494.8192](16Dec 12:48:34.931 ): DynAP (CLIP_S AP): Couldn't get details for registering SU 00c0690b587f
CS[5494.8192](16Dec 12:48:34.931 ): RegistrarProtocol: Deferring deregistration of MID 1
CS[5494.8192](16Dec 12:48:35.426 ): EMSProtocol: received message REGMSG_REGISTER_SU for CS
CS[5494.8192](16Dec 12:48:35.426 ): Protocol: message contents (20 bytes)

CS[5494.8192](16Dec 12:48:35.426 ): Protocol: 00 00 00 00 01 00 00 01 00 14 00 04 00 c0 69 0b 58 7f b5 10
CS[5494.8192](16Dec 12:48:35.426 ): RegistrarProtocol: SU 00c0690b587f is already registering
```

2. The management address must be on the same subnet as the atm0 interface on the Control Server. This only applies for the management address.

3. Check that the PVCs are mapped correctly in the switch. Since the problem is with the SU not registering, pay close attention to the registration (61) and management (280) PVC mapping.

```
ADMIN Access_NGI>show pvc list id 0
ADMIN Access_NGI>
-----
PVC ID IPort IVPI IVCI BW OPort OVPI OVCI BW
-----
1 101 0 32 0 102 0 61 0
2 101 0 33 0 102 0 33 0
3 101 0 36 0 102 0 36 0
4 101 0 35 0 106 0 35 0
```

4. Make sure the Control Server has the created the proper atmarp entries in it. There should be an atmarp entry for every management address.

- Lists atmarp entries

```
[root@cs1 /root]# atmarp -a
----- If 0 (192.168.2.1, netmask 255.255.255.0) -----
Default QOS:ubr,aal5:max_sdu=9188
IP 192.168.2.100, state VALID, addr <none>, flags 0x4<PERM>
  0.0.36
IP 192.168.2.50, state VALID, addr <none>, flags 0x4<PERM>
  0.0.33
----- Unknown incoming connections -----
----- Incoming unidirectional connections -----
----- End of dump -----
```

7.2 Static CLIP_S (routed management)

All assumptions for troubleshooting CLIP_S (routed management) are based on the following diagram.

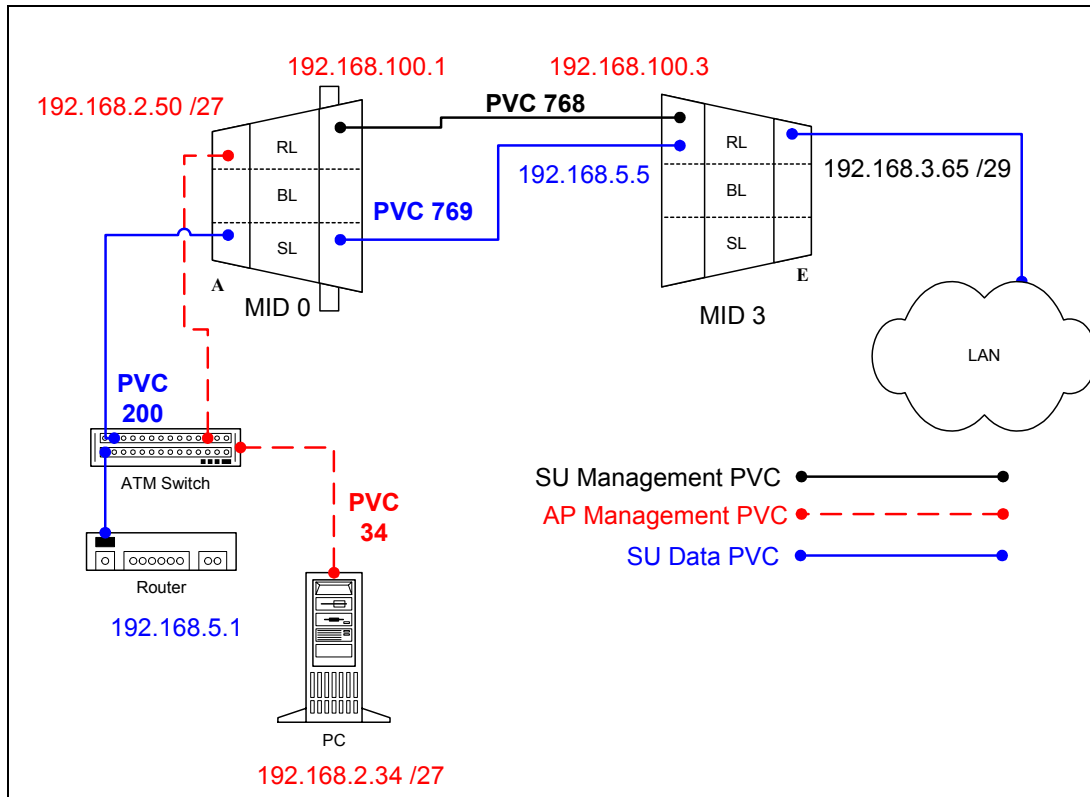

7.2.1 Routed Management PRO/CON

CLIP_S can be configured with switched management or routed management. Read PRO/CON of both to help you decide which you would like use.

PRO

- Only one ATMARP entry will need to be added to the termination router.
- Can be easier to troubleshoot and isolate a problem in the network.

CON

- Need to add a route and ipatm pvc for every SU that is added to the AP.
- May need to add a route to multiple routers for each SU depending upon network design.

7.2.2 AP Configuration Files

7.2.2.1 AP resolve

```
device add atm0 atm //bun mtu 1500 192.168.2.50
device add atm1 atm //bun mtu 1500 192.168.100.1

subnet add atm0.home . 192.168.2.32 ff:ff:ff:e0
subnet add atm1.home . 192.168.100.0 ff:ff:ff:00

rip send all none
rip accept all none

route add default 0.0.0.0 192.168.2.34 00:00:00:00 1 # MAN

relay all

ipatm lifetime 60

ipatm pvc atm0 atm25i 0/34 pcr 70000/70000 remoteip 192.168.2.34
ipatm pvc atm1 atm25m 0/768 pcr 70000/70000 remoteip 192.168.100.3
```

7.2.2.2 AP system.conf

```
channel 0
antenna horizontal
mode static
mid 0
bid 0
interface atm0
backoff 0
provider abw
key Axxcelera
mask 1ffff
leds active
max_mid 254
```

7.2.2.3 AP initswitchcli

```
tp default UBR 2667
sp default 256 stats
add atm25m 0 769 atm25i 0 200 default default perm epd
add atm25i 0 200 atm25m 0 769 default default perm epd
```

7.2.3 SU Configuration Files

7.2.3.1 SU resolve

```
device add eth0 ether //edd mtu 1500 192.168.3.65
device add atm1 atm //bun mtu 1500 192.168.100.3
device add atm2 atm //bun mtu 1500 192.168.5.5

subnet add eth0.home . 192.168.3.64 ff:ff:ff:f8
subnet add atm1.home . 192.168.100.0 ff:ff:ff:00
subnet add atm2.home . 192.168.5.0 ff:ff:ff:00

rip send all none
rip accept all none

route add default 0.0.0.0 192.168.5.1 00:00:00:00 1 # MAN
route add mgmt 192.168.2.32 192.168.100.1 ff:ff:ff:e0 1 # MAN

relay all

ipatm lifetime 60

ipatm pvc atm1 atm25m 0/768 pcr 70000/70000 remoteip 192.168.100.1
ipatm pvc atm2 atm25m 0/769 pcr 70000/70000 remoteip 192.168.5.1
```

7.2.3.2 SU system.conf

```
channel 0
antenna horizontal
mode static
mid 3
bid 0
interface eth0
duplex half
backoff 0
provider abw
key Axxcelera
mask 1ffff
leds active
```

7.2.4 Troubleshooting

7.2.4.1 Can't ping the radio from the terrestrial interface

AP

1. Check all physical connections. It is a straight cable from the CS to the Switch, and a rollover twist from the wall box to the switch (1-7,2-8).
2. Check to see if your atmarp entries are in the ARP table on the CS. (./atmarp if you are already in the /usr/local/sbin directory)

- Add an atmarp entry

```
root@cs1 11:11:14 (4) [~] # atmarp -s 192.168.2.50 0.0.34
```

- View an atmarp table

```
root@cs1 11:12:52 (5) [~] # atmarp -a
---- If 0 (192.168.2.1, netmask 255.255.255.0) ----
Default QOS: ubr,aal5:max_sdu=9188
IP 192.168.2.50, state VALID, addr <none>, flags 0x4<PERM> 0.0.34
---- Unknown incoming connections ----
---- Incoming unidirectional connections ----
---- End of dump ----
```

- Delete an atmarp entry

```
root@cs1 11:13:42 (6) [~] # atmarp -d 192.168.2.50
```

3. Check route on CS, by typing route at the Command line.

- Add a route

```
root@cs1 11:17:19 (8) [~] # route add -net 192.168.100.0 netmask 255.255.255.0 gw 192.168.2.50
```

- View the routing table

```
root@cs1 11:18:51 (9) [~] # route
```

```
Kernel IP routing table
```

Destination	Gateway	Genmask	Flags	Metric	Ref	Use	Iface
10.9.144.1	*	255.255.255.255	UH	0	0	0	eth0
192.168.100.0	192.168.2.50	255.255.255.0	UG	0	0	0	atm0
192.168.2.0	*	255.255.255.0	U	0	0	0	atm0
10.9.144.0	*	255.255.255.0	U	0	0	0	eth0
127.0.0.0	*	255.0.0.0	U	0	0	0	lo

- Delete a route

```
root@cs1 11:20:26 (10) [~] # route del -net 192.168.100.0 netmask 255.255.255.0
```

4. Check the Switch for the correct PVC's.

- Log into the ATM switch and check that the PVCs are mapped correctly. The following commands are for an FVC switch.

- Add a PVC

```
ADMIN Access_NGI>set pvc add 101 0 34 be 102 0 34 be
```

```
Adding PVC i=101/0/34 o=102/0/34 to switch fabrice
```

```
Updating FLASH memory. Please wait ... Done.
```

- Show the PVCs mapped in the switch

```
ADMIN Access_NGI>show pvc list id 0
```

```
-----
PVC ID IPort IVPI IVCI BW OPort OVPI OVCI BW
-----
1 101 0 34 0 102 0 34 0
```

- Delete a PVC

```
ADMIN Access_NG1>set pvc del 1
```

SU

1. Check all physical connections. The radio is a network device, which means if you connect it to a PC (NIC) you will use a straight cable. If you connect the radio to a network device (hub, switch, router) you will use a Ethernet cross-over cable(1-3, 2-6). It is also important to check that the cable is punched down correctly in the wall box and the cable is terminated correctly at the radio. The termination at the radio uses 568B (wo,o,wg,bl,wbl,g,wbr,br).

2. Make sure the computer you are pinging from is on the same network as the AP. If you are on a different network than the radio make sure you have the proper routes in the radio and the computer you are trying to ping from.

7.2.4.2 Can't ping across the wireless link

There are numerous reason why you couldn't ping across the wireless link. After following these troubleshooting steps and you still can't ping across the wireless link refer to the RF troubleshooting document.

1. Check that SU has the proper MID.

```
192.168.3.10 hmm> system mid  
MID 3
```

2. Check the ipatm pvc is correct in relation to the MID and remoteip

AP

```
192.168.2.50 ip> ipatm pvc  
ipatm pvc atm1 atm25m 0/768 pcr 70000/70000 remoteip 192.168.100.3
```

SU

```
192.168.3.65 ip> ipatm pvc  
ipatm pvc atm1 atm25m 0/768 pcr 70000/70000 remoteip 192.168.100.1
```

3. Check the default route in the SU.

```
192.168.3.65 ip> route  
route add default 0.0.0.0 192.168.100.1 00:00:00:00 1 # MAN via atm1
```

4. Check that there is a route in the AP that points to the SU's terrestrial network.

```
192.168.2.50 ip> route
route add su1 192.168.3.64 192.168.100.3 ff:ff:f8 1 # MAN via atm1
route add default 0.0.0.0 192.168.2.34 00:00:00:00 1 # MAN via atm0
```

7.3 Static CLIP_S (switched management)

All assumptions for troubleshooting CLIP_S are based on the following diagram.

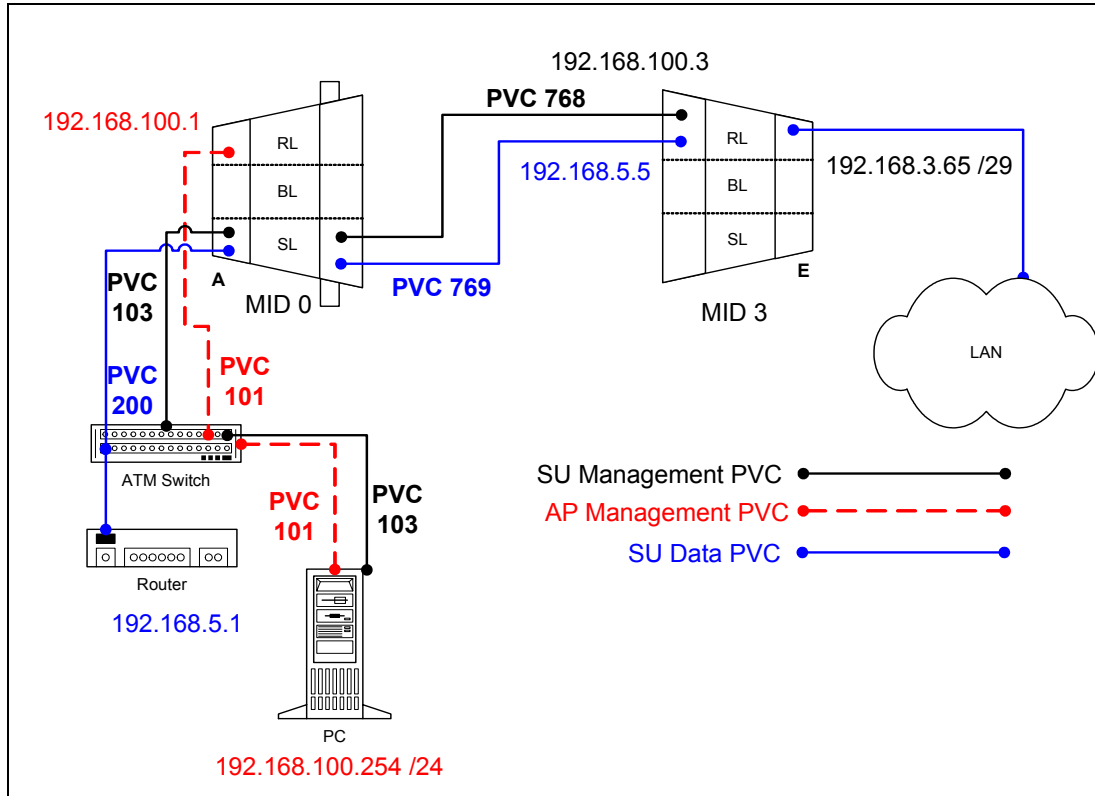

7.3.1 Switched Management PRO/CON

CLIP_S can be configured with switched management or routed management. Read PRO/CON of both to help you decide which you would like use.

PRO

- No extra mgmt routes will have to be added to the termination router.
- Multiple routes will not have to be added to network routers with the addition of each SU.

CON

- Will need to add an atmarp entry for each SU in the termination router.
- Will need to add a management PVC in the switchcli of the AP for each SU.

7.3.2 AP Configuration Files

7.3.2.1 AP resolve

```
device add atm0 atm //bun mtu 1500 192.168.100.1

subnet add atm0.home . 192.168.100.0 ff:ff:ff:00

rip send all none
rip accept all none

route add default 0.0.0.0 192.168.100.254 00:00:00:00 1 # MAN

relay all

ipatm lifetime 60

ipatm pvc atm0 atm25i 0/101 pcr 70000/70000 remoteip 192.168.100.254
```

7.3.2.2 AP system.conf

```
channel 0
antenna horizontal
mode static
mid 0
bid 0
interface atm0
backoff 0
provider abw
key Axxcelera
mask 1ffff
leds active
max_mid 254
```

7.3.2.3 AP initswitchcli

```
tp default UBR 2667
sp default 256 stats
add atm25m 0 768 atm25i 0 103 default default perm epd
add atm25i 0 103 atm25m 0 768 default default perm epd
add atm25m 0 769 atm25i 0 200 default default perm epd
add atm25i 0 200 atm25m 0 769 default default perm epd
```

7.3.3 SU Configuration Files

7.3.3.1 SU resolve

```
device add eth0 ether //edd mtu 1500 192.168.3.65
device add atm1 atm //bun mtu 1500 192.168.100.3
device add atm2 atm //bun mtu 1500 192.168.5.5

subnet add eth0.home . 192.168.3.64 ff:ff:ff:f8
subnet add atm1.home . 192.168.100.0 ff:ff:ff:00
subnet add atm2.home . 192.168.5.0 ff:ff:ff:00

rip send all none
rip accept all none

route add default 0.0.0.0 192.168.5.1 00:00:00:00 1 # MAN

relay all

ipatm lifetime 60

ipatm pvc atm1 atm25m 0/768 pcr 70000/70000 remoteip 192.168.100.254
ipatm pvc atm2 atm25m 0/769 pcr 70000/70000 remoteip 192.168.5.1
```

7.3.3.2 SU system.conf

```
channel 0
antenna horizontal
mode static
mid 3
bid 0
interface eth0
duplex half
backoff 0
provider abw
key Axxcelera
mask 1ffff
leds active
```

7.3.4 Troubleshooting

7.3.4.1 Can't ping the radio from the terrestrial interface

AP

1. Check all physical connections. It is a straight cable from the CS to the Switch, and a rollover twist from the wall box to the switch (1-7,2-8).
2. Check to see if your atmarp entries are in the ARP table on the CS. (./atmarp if you are already in the /usr/local/sbin directory)

- Add an atmarp entry

```
root@cs1 11:11:14 (4) [~] # atmarp -s 192.168.100.1 0.0.101
```

- View an atmarp table

```
root@cs1 11:12:52 (5) [~] # atmarp -a
---- If 0 (192.168.100.254, netmask 255.255.255.0) ----
Default QOS: ubr,aal5:max_sdu=9188
IP 192.168.100.1, state VALID, addr <none>, flags 0x4<PERM> 0.0.101
---- Unknown incoming connections ----
---- Incoming unidirectional connections ----
---- End of dump ----
```

- Delete an atmarp entry

```
root@cs1 11:13:42 (6) [~] # atmarp -d 192.168.100.1
```

3. Check the Switch for the correct PVC's.
 - Log into the ATM switch and check that the PVCs are mapped correctly. The following commands are for an FVC switch.

- Add a PVC

```
ADMIN Access_NGI>set pvc add 101 0 101 be 102 0 101 be
```

```
Adding PVC i=101/0/34 o=102/0/34 to switch fabric
Updating FLASH memory. Please wait ... Done.
```

- Show the PVCs mapped in the switch

```
ADMIN Access_NGI>show pvc list id 0
```

```
-----
PVC ID IPort IVPI IVCI BW OPort OVPI OVCI BW
-----
1 101 0 101 0 102 0 101 0
```

- Delete a PVC

```
ADMIN Access_NGI>set pvc del 1
```

SU

1. Check all physical connections. The radio is a network device, which means if you connect it to a PC (NIC) you will use a straight cable. If you connect the radio to a network device (hub, switch, router) you will use a Ethernet cross-over cable(1-3, 2-6). It is also important to check that the cable is punched down correctly in the wall box and the cable is terminated correctly at the radio. The termination at the radio uses 568B (wo,o,wg,bl,wbl,g,wbr,br).

2. Make sure the computer you are pinging from is on the same network as the AP. If you are on a different network than the radio make sure you have the proper routes in the radio and the computer you are trying to ping from.

7.3.4.2 Can't ping across the wireless link

There are numerous reason why you couldn't ping across the wireless link. After following these troubleshooting steps and you still can't ping across the wireless link refer to the RF troubleshooting document.

1. Check that SU has the proper MID.

```
192.168.3.10 hmm> system mid
MID 3
```

2. Check the that the pvc information is correct in relation to the MID and remoteip

AP

```
192.168.100.254 switchcli> list all all perm
```

Displaying permanent entries for all ports.

port	vp	vc	port	vp	vc
atm25i	0	103 ==>	atm25m	0	768
atm25m	0	768 ==>	atm25i	0	103
atm25i	0	200 ==>	atm25m	0	769
atm25m	0	769 ==>	atm25i	0	200

SU

```
192.168.3.65 ip> ipatm pvc
```

```
ipatm pvc atm1 atm25m 0/768 pcr 70000/70000 remoteip 192.168.100.1
```

3. Check the default route in the SU.

```
192.168.3.65 ip> route
```

```
route add default 0.0.0.0 192.168.100.254 00:00:00:00 1 # MAN via atm1
```

8 Hybrid CLIP_S

The Hybrid CLIP_S configuration is a configuration that can be added onto an existing CLIP_S static configuration. What this configuration allows you to do is create a VPN type tunnel between two SUs across a network. This allows for two data paths: one to another private network, and another to the internet. This can be done with either a switched or routed management system.

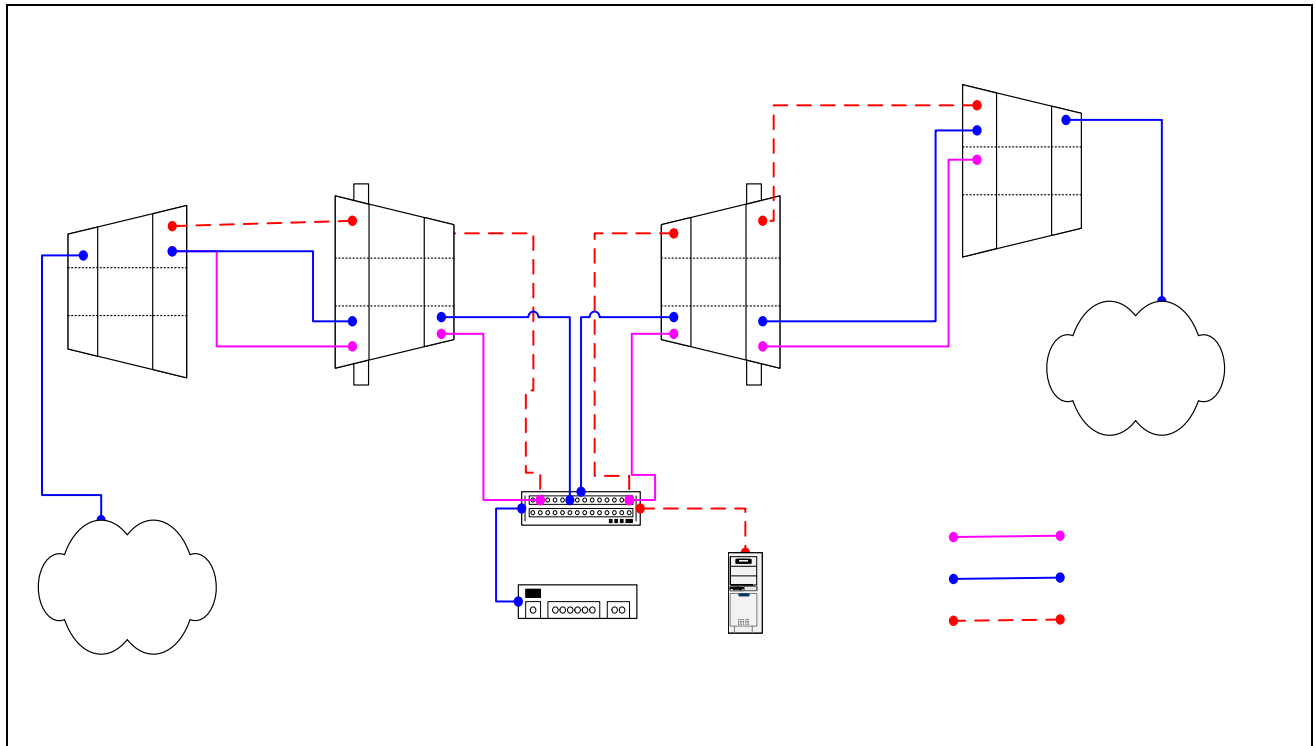

8.1.1 AP1 Configuration Files

8.1.1.1 AP1 resolve

```
device add atm0 atm //bun mtu 1500 192.168.2.50
device add atm1 atm //bun mtu 1500 192.168.100.1

subnet add atm0.home . 192.168.2.32 ff:ff:ff:e0
subnet add atm1.home . 192.168.100.0 ff:ff:ff:00

rip send all none
rip accept all none

route add default 0.0.0.0 192.168.2.34 00:00:00:00 1 # MAN

relay all

ipatm lifetime 60

ipatm pvc atm0 atm25i 0/50 pcr 70000/70000 remoteip 192.168.2.34
ipatm pvc atm1 atm25m 0/768 pcr 70000/70000 remoteip 192.168.100.3
```

8.1.1.2 AP1 system.conf

```
channel 0
antenna horizontal
mode static
mid 0
bid 0
interface atm0
backoff 0
provider abw
key Axxcelera
mask 1fff
leds active
max_mid 254
```

8.1.1.3 AP1 initswitchcli

```
tp default UBR 2667
sp default 256 stats
add atm25m 0 769 atm25i 0 100 default default perm epd
add atm25i 0 100 atm25m 0 769 default default perm epd
add atm25m 0 770 atm25i 0 200 default default perm epd
add atm25i 0 200 atm25m 0 770 default default perm epd
```

8.1.2 SU1 Configuration Files

8.1.2.1 SU1 resolve

```
device add eth0 ether //edd mtu 1500 192.168.3.65
device add atm1 atm //bun mtu 1500 192.168.100.3
device add atm2 atm //bun mtu 1500 192.168.5.5

subnet add eth0.home . 192.168.3.64 ff:ff:ff:f8
subnet add atm1.home . 192.168.100.0 ff:ff:ff:00
subnet add atm2.home . 192.168.5.0 ff:ff:ff:00

rip send all none
rip accept all none

route add default 0.0.0.0 192.168.5.1 00:00:00:00 1 # MAN
route add su2 192.168.4.64 192.168.5.6 ff:ff:ff:f8 1 # MAN
route add mgmt 192.168.2.32 192.168.100.1 ff:ff:ff:e0 1 # MAN

relay all

ipatm lifetime 60

ipatm pvc atm1 atm25m 0/768 pcr 70000/70000 remoteip 192.168.100.1
ipatm pvc atm2 atm25m 0/769 pcr 70000/70000 remoteip 192.168.5.1
ipatm pvc atm2 atm25m 0/770 pcr 70000/70000 remoteip 192.168.5.6
```

8.1.2.2 SU1 system.conf

```
channel 0
antenna horizontal
mode static
mid 3
bid 0
interface eth0
duplex half
backoff 0
provider abw
key Axxcelera
mask 1fff
leds active
```

8.1.3 AP2 Configuration Files

8.1.3.1 AP2 resolve

```
device add atm0 atm //bun mtu 1500 192.168.2.51
device add atm1 atm //bun mtu 1500 192.168.101.1

subnet add atm0.home . 192.168.2.32 ff:ff:ff:e0
subnet add atm1.home . 192.168.101.0 ff:ff:ff:00

rip send all none
rip accept all none

route add default 0.0.0.0 192.168.2.34 00:00:00:00 1 # MAN

relay all

ipatm lifetime 60

ipatm pvc atm0 atm25i 0/51 pcr 70000/70000 remoteip 192.168.2.34
ipatm pvc atm1 atm25m 0/768 pcr 70000/70000 remoteip 192.168.101.3
```

8.1.3.2 AP2 system.conf

```
channel 2
antenna horizontal
mode static
mid 0
bid 0
interface atm0
backoff 0
provider abw
key Axxcelera
mask 1ffff
leds active
max_mid 254
```

8.1.3.3 AP2 initswitchcli

```
tp default UBR 2667
sp default 256 stats
add atm25m 0 769 atm25i 0 101 default default perm epd
add atm25i 0 101 atm25m 0 769 default default perm epd
add atm25m 0 770 atm25i 0 200 default default perm epd
add atm25i 0 200 atm25m 0 770 default default perm epd
```

8.1.4 SU2 Configuration Files

8.1.4.1 SU2 resolve

```
device add eth0 ether //edd mtu 1500 192.168.4.65
device add atm1 atm //bun mtu 1500 192.168.101.3
device add atm2 atm //bun mtu 1500 192.168.5.6

subnet add eth0.home . 192.168.4.64 ff:ff:ff:f8
subnet add atm1.home . 192.168.101.0 ff:ff:ff:00
subnet add atm2.home . 192.168.5.0 ff:ff:ff:00

rip send all none
rip accept all none

route add default 0.0.0.0 192.168.5.1 00:00:00:00 1 # MAN
route add su1 192.168.3.64 192.168.5.5 ff:ff:ff:f8 1 # MAN
route add mgmt 192.168.2.32 192.168.101.1 ff:ff:ff:e0 1 # MAN

relay all

ipatm lifetime 60

ipatm pvc atm1 atm25m 0/768 pcr 70000/70000 remoteip 192.168.101.1
ipatm pvc atm2 atm25m 0/769 pcr 70000/70000 remoteip 192.168.5.1
ipatm pvc atm2 atm25m 0/770 pcr 70000/70000 remoteip 192.168.5.5
```

8.1.4.2 SU2 system.conf

```
channel 2
antenna horizontal
mode static
mid 3
bid 0
interface eth0
duplex half
backoff 0
provider abw
key Axxcelera
mask 1fff
leds active
```

8.1.5 Troubleshooting

8.1.5.1 Can't ping the radio from the terrestrial interface

AP

1. Check all physical connections. It is a straight cable from the CS to the Switch, and a rollover twist from the wall box to the switch (1-7,2-8).

2. Check to see if your atmarp entries are in the ARP table on the CS. (./atmarp if you are already in the /usr/local/sbin directory)

- Add an atmarp entry

```
root@cs1 11:11:14 (4) [~] # atmarp -s 192.168.2.50 0.0.34
```

- View an atmarp table

```
root@cs1 11:12:52 (5) [~] # atmarp -a
----- If 0 (192.168.2.1, netmask 255.255.255.0) -----
Default QOS:ubr,aal5:max_sdu=9188
IP 192.168.2.50, state VALID, addr <none>, flags 0x4<PERM> 0.0.34
----- Unknown incoming connections -----
----- Incoming unidirectional connections -----
----- End of dump -----
```

- Delete an atmarp entry

```
root@cs1 11:13:42 (6) [~] # atmarp -d 192.168.2.50
```

3. Check route on CS, by typing route at the Command line.

- Add a route

```
root@cs1 11:17:19 (8) [~] # route add -net 192.168.100.0 netmask 255.255.255.0 gw 192.168.2.50
```

- View the routing table

```

root@cs1 11:18:51 (9) [-] # route
Kernel IP routing table
Destination Gateway Genmask Flags Metric Ref Use Iface
10.9.144.1 * 255.255.255.255 UH 0 0 0 eth0
192.168.100.0 192.168.2.50 255.255.255.0 UG 0 0 0 atm0
192.168.2.0 * 255.255.255.0 U 0 0 0 atm0
10.9.144.0 * 255.255.255.0 U 0 0 0 eth0
127.0.0.0 * 255.0.0.0 U 0 0 0 lo

```

- Delete a route

```

root@cs1 11:20:26 (10) [-] # route del -net 192.168.100.0 netmask 255.255.255.0

```

4. Check the Switch for the correct PVC's.

- Log into the ATM switch and check that the PVCs are mapped correctly. The following commands are for an FVC switch.

- Add a PVC

```

ADMIN Access_NGI>set pvc add 101 0 34 be 102 0 34 be

```

```

Adding PVC i=101/0/34 o=102/0/34 to switch fabric
Updating FLASH memory. Please wait ... Done.

```

- Show the PVCs mapped in the switch

```

ADMIN Access_NGI>show pvc list id 0
-----
PVC ID IPort IVPI IVCI BW OPort OVPI OVCI BW
-----
1 101 0 34 0 102 0 34 0

```

- Delete a PVC

```

ADMIN Access_NGI>set pvc del 1

```

SU

1. Check all physical connections. The radio is a network device, which means if you connect it to a PC (NIC) you will use a straight cable. If you connect the radio to a network device (hub, switch, router) you will use a Ethernet cross-over cable(1-3, 2-6). It is also important to check that the cable is punched down correctly in the wall box and the cable is

terminated correctly at the radio. The termination at the radio uses 568B (wo,o,wg,bl,wbl,g,wbr,br).

2. Make sure the computer you are pinging from is on the same network as the AP. If you are on a different network than the radio make sure you have the proper routes in the radio and the computer you are trying to ping from.

8.1.5.2 Can't ping across the wireless link

There are numerous reason why you couldn't ping across the wireless link. After following these troubleshooting steps and you still can't ping across the wireless link refer to the RF troubleshooting document.

1. Check that SU has the proper MID.

```
192.168.3.10 hmm> system mid
MID 3
```

2. Check the ipatm pvc is correct in relation to the MID and remoteip

AP

```
192.168.2.50 ip> ipatm pvc
ipatm pvc atm1 atm25m 0/768 pcr 70000/70000 remoteip 192.168.100.3
```

SU

```
192.168.3.65 ip> ipatm pvc
ipatm pvc atm1 atm25m 0/768 pcr 70000/70000 remoteip 192.168.100.1
```

3. Check the default route in the SU.

```
192.168.3.65 ip> route
route add default 0.0.0.0 192.168.100.1 00:00:00:00 1 # MAN via atm1
```

4. Check that there is a route in the AP that points to the SU's terrestrial network.

```
192.168.2.50 ip> route
route add su1 192.168.3.64 192.168.100.3 ff:ff:f8 1 # MAN via atm1
route add default 0.0.0.0 192.168.2.34 00:00:00:00 1 # MAN via atm0
```

9 1483_T

The 1483_T configuration is where both the AP and the SU act as a layer 2 bridge. It is important to understand that in this configuration data can only go from SU-AP & AP-SU within the sector. Data will not be able to from SU-SU within the same sector. This can only be done by connecting a router to the AP and redirecting that traffic back to the AP.

9.1 Interactive 1483_T

All assumptions for troubleshooting 1483_T are based on the following diagram.

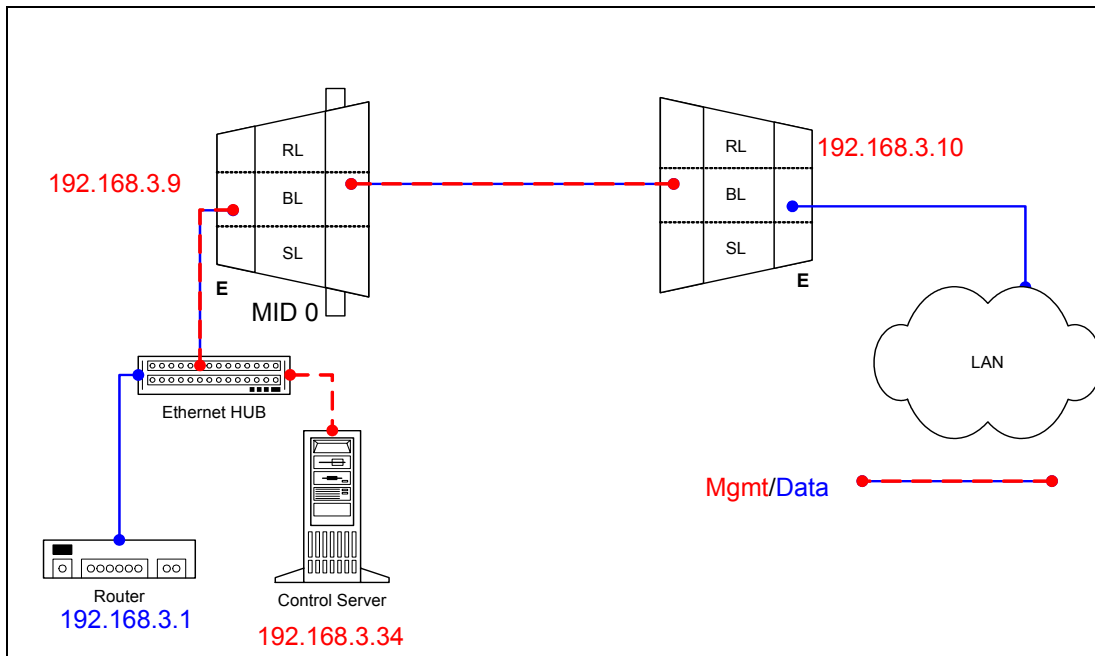

9.1.1 Adding AP or SU to EMS

Dialogue boxes showing the information needed to add an AP or SU are shown below.

New Access Point

Config | Alarm

Name: 1483_T AP

Configuration: 1483 terminated (RFC 1483)

Interface: Ethernet

General

MAC address: 00:c0:69:0c:52:2f Unit type: U-NII

Location: Lab Alarm profile: (default)

Base Station: Lab BS Availability state: Available

Telnet password: *****

IP

Management address: 192.168.3.9

Radio

Channel: 0 Direction: 180

Polarization: Horizontal

OK Apply Cancel

New Access Point

Config Alarm

Name: 1483_T AP

Configuration: 1483 terminated (RFC 1483)

Interface: Ethernet

General

MAC address: 00:c0:69:0c:52:2f Unit type: U-NII

Location: Lab Alarm profile: (default)

Base Station: Lab BS Availability state: Available

Telnet password: *****

IP

Management address: 192.168.3.9

Radio

Channel: 0 Direction: 180

Polarization: Horizontal

OK Apply Cancel

9.1.2 Troubleshooting

9.1.2.1 AP Object

If the AP will not register make sure all the fields in the EMS database are correctly filled in. Here are a few important points that should be kept in mind if the AP doesn't register.

1. See if you can ping the unit. The default configuration is to have the AP receive a DHCP address from the CS. If it has not received it you will not be able to ping it. So if you are unable to ping the AP you should check and see that the dhcpd.conf file is setup properly. Notice that in the example AP1 has a fixed address set, each AP must be given the same address every time it leases an address. It is important to be aware that by default most routers will not pass DHCP request unless they are specifically configured to do so.

```
#eth0
subnet 192.168.3.0 netmask 255.255.255.0 {
    range 192.168.3.1 192.168.3.100;
    option routers 192.168.3.1;
}

host AP1 {
    hardware ethernet 0:c0:69:0c:52:2f;
    fixed-address 192.168.3.9;
}
```

For various reasons it may be desired to not use DHCP to give an AP an address. In this case the IP address can be statically assigned to the unit. To do this you will need to create a resolve file that looks identical to the 1483_T static resolve file described in the section for Static 1483_T.

2. Make sure the MAC address is correct. Without the correct MAC address the AP can not register. You can verify this by tailing the adapcs.log file. In this example an SU with the indicated MAC address is trying to register and is not found in the database. Either the SU was not added to the EMS or was entered with the wrong MAC address.

```
[root@cs1 /root]# tail -f /var/log/adapcs.log
```

```
CS[12399.8192](16Dec 21:33:39.524 ): Protocol: 00 00 00 00 01 00 02 00 00 14 00 01 00 c0 69 0c 52 2f 77 94
CS[12399.8192](16Dec 21:33:39.524 ): DynAccessPointImpl (1483_T AP): handleEstablishConnection (AP 00c0690c522f)
CS[12399.8192](16Dec 21:33:39.524 ): DynAccessPointImpl (1483_T AP): Received ESTABLISH_CONNECTION message
from unknown AP ap_02 1216_135100016_111
```

3. If the CS is on a different network, than the default route in the AP must be correct.

9.1.2.2 SU Object

If the SU will not register make sure all the fields in the EMS database are filled in properly. Here are a few important points that should be kept in mind if the SU doesn't register. Many different things can cause the SU not to register so after verifying all of these points and it still doesn't register the next step will be to troubleshoot the RF link. See RF troubleshooting.

1. Make sure the MAC address is correct. Without the correct MAC address the AP can not register. You can verify this by tailing the adapcs.log file. In this example an SU with this MAC address is trying to register and is not found in the database, which means when you created the object it had the wrong MAC address.

```
[root@cs1 /root]# tail -f /var/log/adapcs.log
```

```
CS[12801.8192](16Dec 21:39:20.034 ): Protocol: 00 00 00 00 01 00 00 05 00 14 00 04 00 c0 69 0b 58 7f b5 10
CS[12801.8192](16Dec 21:39:20.034 ): RegistrarProtocol: SU 00c0690b587f is already registering
```

CS[12801.8192](16Dec 21:39:20.555): EMSProtocol: received message REGMSG_REGISTER_SU for CS
CS[12801.8192](16Dec 21:39:20.555): Protocol: message contents (20 bytes)

2. Make sure the default route is correct if the SU is on a different network than the Control Server.
3. Verify that the SU has been upgraded to the 1483_T interactive configuration.

9.2 Static 1483_T

All assumptions for troubleshooting 1483_T will be based on the following diagram.

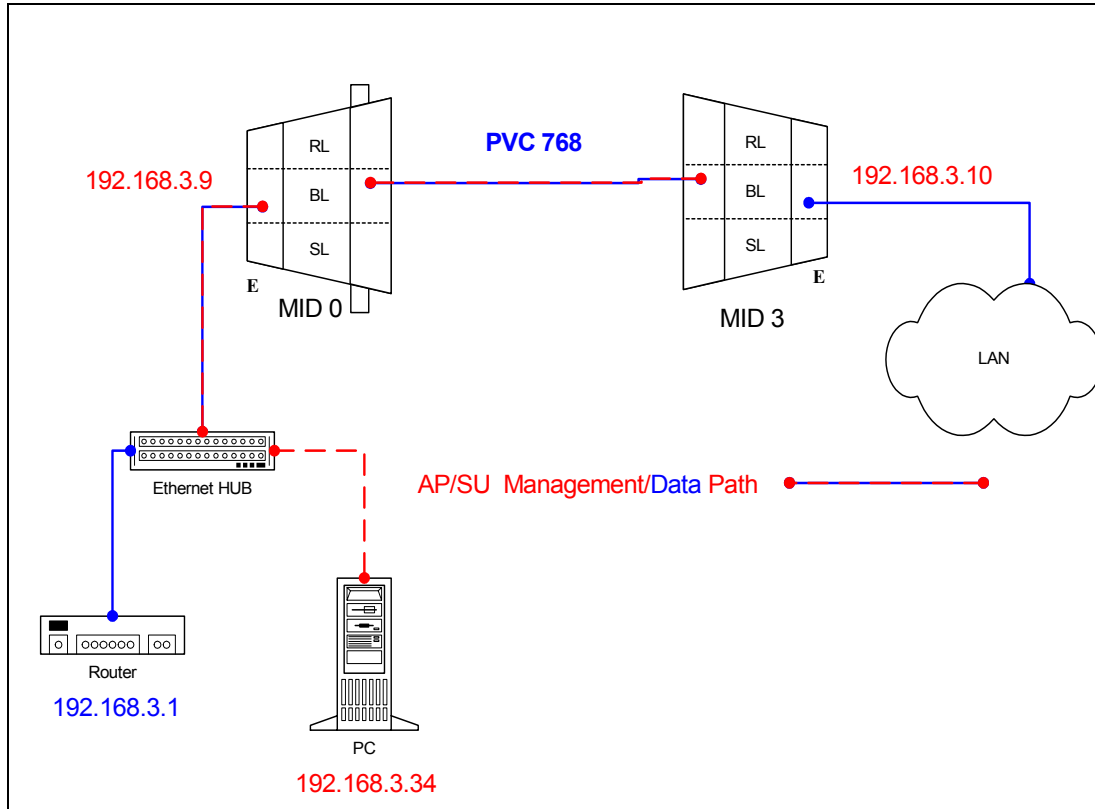

9.2.1 AP Configuration Files

9.2.1.1 AP resolve

```
device add bridge ether //bridge mtu 1500 192.168.3.9
subnet add bridge.home . 192.168.3.0 ff:ff:ff:00
rip send all none
rip accept all none
route add default 0.0.0.0 192.168.3.1 00:00:00:00 1 # MAN
relay all
ipatm lifetime 60
```

9.2.1.2 AP initbridge

```
spanning disable  
device add edd  
device add mr1483
```

9.2.1.3 AP initmr1483

```
floodmode 1  
up 3 768 atm25m 70000 70000
```

9.2.1.4 AP system.conf

```
channel 0  
antenna horizontal  
mode static  
mid 0  
bid 0  
interface eth0  
backoff 0  
provider abw  
key Axxcelera  
mask 1fff  
leds active  
max_mid 254
```

9.2.2 SU Configuration Files**9.2.2.1 SU resolve**

```
device add bridge ether //bridge mtu 1500 192.168.3.10  
subnet add bridge.home . 192.168.3.0 ff:ff:ff:00  
rip send all none  
rip accept all none  
route add default 0.0.0.0 192.168.3.1 00:00:00:00 1 # MAN  
relay all  
ipatm lifetime 60
```

9.2.2.2 SU initbridge

```
spanning disable
device add add
device add r1483
```

9.2.2.3 SU system.conf

```
channel 0
antenna horizontal
mode static
mid 3
bid 0
interface eth0
backoff 0
provider abw
key Axxcelera
mask 1fff
leds active
```

9.2.2.4 SU in1483

```
pvc 0/768 atm25m 70000 70000
```

9.2.3 Troubleshooting**9.2.3.1 Can't ping the radio from the terrestrial interface.**

1. Check all physical connections. The radio is a network device, which means if you connect it to a PC (NIC) you will use a straight cable. If you connect the radio to a network device (hub, switch, router) you will use a Ethernet cross-over cable(1-3, 2-6). It is also important to check that the cable is punched down correctly in the wall box and the cable is terminated correctly at the radio. The termination at the radio uses 568B (wo,o,wg,bl,wbl,g,wbr,br).

2. Make sure the computer you are pinging from is on the same network as the AP. If you are on a different network than the radio make sure you have the proper routes in the radio and the computer you are trying to ping from.

9.2.3.2 Can't ping the radio across the wireless link.

There can be numerous reasons why you can't ping across the wireless link. After following these troubleshooting steps and you still can't ping across the wireless link refer to the RF troubleshooting document.

1. Check the 1483 processes in the radios. Make sure they are active and have the correct PVC mapped.

AP (mr1483 command)

```
192.168.3.9 > mr1483 status 3
Device 3 is active
Active PVC: 768 Active port: atm25m
Pending PVC: 768 Pending port: atm25m
Active devices:
3
1 active in total
```

SU (r1483 command)

```
192.168.3.10 > r1483 pvc
Active PVC: 0/768
Active port: atm25m
```

10 1483_S

In this configuration the AP acts as at ATM switch passing all cells at layer 2. The SU acts as a 1483 Bridge.

10.1 Interactive 1483_S

All assumptions for troubleshooting 1483_S are based on the following diagram.

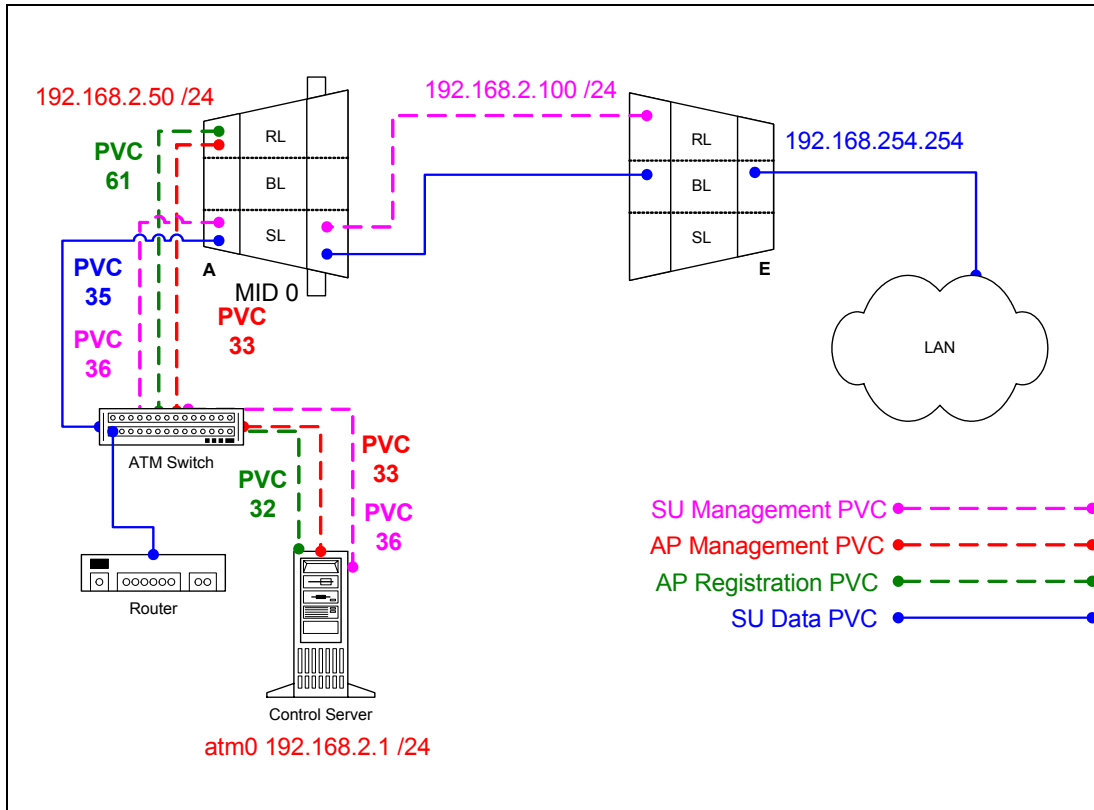

10.1.1 Adding AP and SU to EMS

Dialogue boxes showing the information needed to add an AP or SU are shown below.

New Access Point

Config | Alarm

Name: 1483_S AP

Configuration: 1483 switched (RFC 1483)

Interface: ATM

General

MAC address: 00:c0:69:0c:52:2f Unit type: U-NII

Location: Lab Alarm profile: (default)

Base Station: Lab BS Availability state: Available

Telnet password: *****

IP

Management address: 192.168.2.50

Management netmask: 255.255.255.0

Radio

Channel: 0 Direction: 180

Polarization: Horizontal

ATM

Management VC at CS: 0.33 Management VC at AS: 0.33

Registration VC at CS: 0.32 Registration VC at AS: 0.32

AS port: 101

OK Apply Cancel

New Subscriber Unit

Config | Alarm

Name: 1483_S SU

Configuration: 1483 switched (RFC 1483)

Interface: Ethernet

General

MAC address: 00:c0:69:0b:58:7f Alarm profile: (default)

Location: Lab Availability state: Available

Unit type: U-NII Authentication key: axx

Telnet password: ***** Assigned Access Point: Dynamic

IP

Management address: 192.168.2.100

Management netmask: 255.255.255.0

ATM

Data VC at AS: 0 . 35 Upstream PCR: 70000 Cells/s

Management VC at AS: 0 . 36 Downstream PCR: 70000 Cells/s

Management VC at CS: 0 . 36

OK Apply Cancel

10.1.2 Troubleshooting

10.1.2.1 AP Object

If the AP will not register make sure all the fields in the EMS database are correctly filled in. Here are a few important points that should be kept in mind if the AP doesn't register.

1. Make sure the MAC address is correct. Without the correct MAC address the AP can not register. You can verify what MAC address the AP is attempting to register with by tailing the adapcs.log file. In the following example an AP is trying to register and is not found in the database, which means when you created the object it had the wrong MAC address.

```
[root@cs1 /root]# tail -f /var/log/adapcs.log
```

```
CS[5025.8192](16Dec 12:36:03.027): AtmAccessPointImpl: Unknown ATM AP 00c0690c522f trying to register
```

2. The management address must be on the same subnet as the atm0 interface on the Control Server.

3. Check that the PVCs are mapped correctly in the switch. Since the problem is with the AP registering, pay close attention to how the registration PVC (61) and management PVC are mapped.

```
ADMIN Access_NGI>show pvc list id 0
ADMIN Access_NGI>
-----
PVC ID IPort IVPI IVCI BW OPort OVPI OVCI BW
-----
1 101 0 32 0 102 0 61 0
2 101 0 33 0 102 0 33 0
```

4. The “AS Port” has to be filled in with the proper port if you have chosen to manage the anchor switch with the EMS (selected when creating the Control Server).

5. Make sure the Control Server has the created the proper atmarp entries in it. There should be an atmarp entry for every management address.

- Lists atmarp entries

```
[root@cs1 /root]# atmarp -a
---- If 0 (192.168.2.1, netmask 255.255.255.0) ----
Default QOS: ubr,aal5:max_sdu=9188
IP 192.168.2.50, state VALID, addr <none>, flags 0x4<PERM> 0.0.33
---- Unknown incoming connections ----
---- Incoming unidirectional connections ----
---- End of dump ----
```

10.1.2.2 SU Object

If the SU will not register make sure all the fields in the EMS database are filled in properly. Here are a few important points that should be kept in mind if the SU doesn't register. Many different things can cause the SU not to register so after verifying all of these points and it still doesn't register the next step will be to troubleshoot the RF link. See RF troubleshooting document.

1. Make sure the MAC address is correct. Without the correct MAC address the SU can not register. You can verify this by tailing the adapcs.log file. In this example an SU with this MAC address is trying to register and is not found in the database, which means when you created the object it had the wrong MAC address.

```
[root@cs1 /root]# tail -f /var/log/adapcs.log
CS[5494.8192](16Dec 12:48:34.926 ): Protocol: 00 00 00 00 01 00 00 01 00 14 00 04 00 c0 69 0b 58 7f b5 10
CS[5494.8192](16Dec 12:48:34.926 ): RegistrarProtocol: Registering SU 00c0690b587f (MID 1)
CS[5494.8192](16Dec 12:48:34.926 ): DynAccessPointImpl (1483_S AP): handleRegisterSU (SU 00c0690b587f)
CS[5494.8192](16Dec 12:48:34.926 ): DynAccessPointImpl (1483_S AP): no key - fetch details from EMSAgent
CS[5494.8192](16Dec 12:48:34.930 ): DynAccessPointImpl: CORBA::BAD_PARAM exception thrown (minor code=0)
CS[5494.8192](16Dec 12:48:34.930 ): DynAccessPointImpl: An SU is trying to register but I can't talk to an EMSAgent
CS[5494.8192](16Dec 12:48:34.931 ): DynAP (1483_S AP): Couldn't get details for registering SU 00c0690b587f
CS[5494.8192](16Dec 12:48:34.931 ): RegistrarProtocol: Deferring deregistration of MID 1
CS[5494.8192](16Dec 12:48:35.426 ): EMSProtocol: received message REGMSG_REGISTER_SU for CS
CS[5494.8192](16Dec 12:48:35.426 ): Protocol: message contents (20 bytes)

CS[5494.8192](16Dec 12:48:35.426 ): Protocol: 00 00 00 00 01 00 00 01 00 14 00 04 00 c0 69 0b 58 7f b5 10
CS[5494.8192](16Dec 12:48:35.426 ): RegistrarProtocol: SU 00c0690b587f is already registering
```

2. The management address must be on the same subnet as the atm0 interface on the Control Server. This only applies for the management address.

3. Check that the PVCs are mapped correctly in the switch. Since the problem is with the SU not registering, pay close attention to the registration (61) and management (280) PVC mapping.

```
ADMIN Access_NGI>show pvc list id 0
ADMIN Access_NGI>
-----
PVC ID IPort IVPI IVCI BW OPort OVPI OVCI BW
-----
1 101 0 32 0 102 0 61 0
2 101 0 33 0 102 0 33 0
3 101 0 36 0 102 0 36 0
4 101 0 35 0 106 0 35 0
```

4. Make sure the Control Server has the created the proper atmarp entries in it. There should be an atmarp entry for every management address.

- Lists atmarp entries

```
[root@cs1 /root]# atmarp -a
----- If 0 (192.168.2.1, netmask 255.255.255.0) -----
Default QOS: ubr,aal5:max_sdu=9188
IP 192.168.2.100, state VALID, addr <none>, flags 0x4<PERM>
  0.0.36
IP 192.168.2.50, state VALID, addr <none>, flags 0x4<PERM>
  0.0.33
----- Unknown incoming connections -----
----- Incoming unidirectional connections -----
----- End of dump -----
```

10.2 Static 1483_S (routed management)

All assumptions for troubleshooting 1483_S are based on the following diagram.

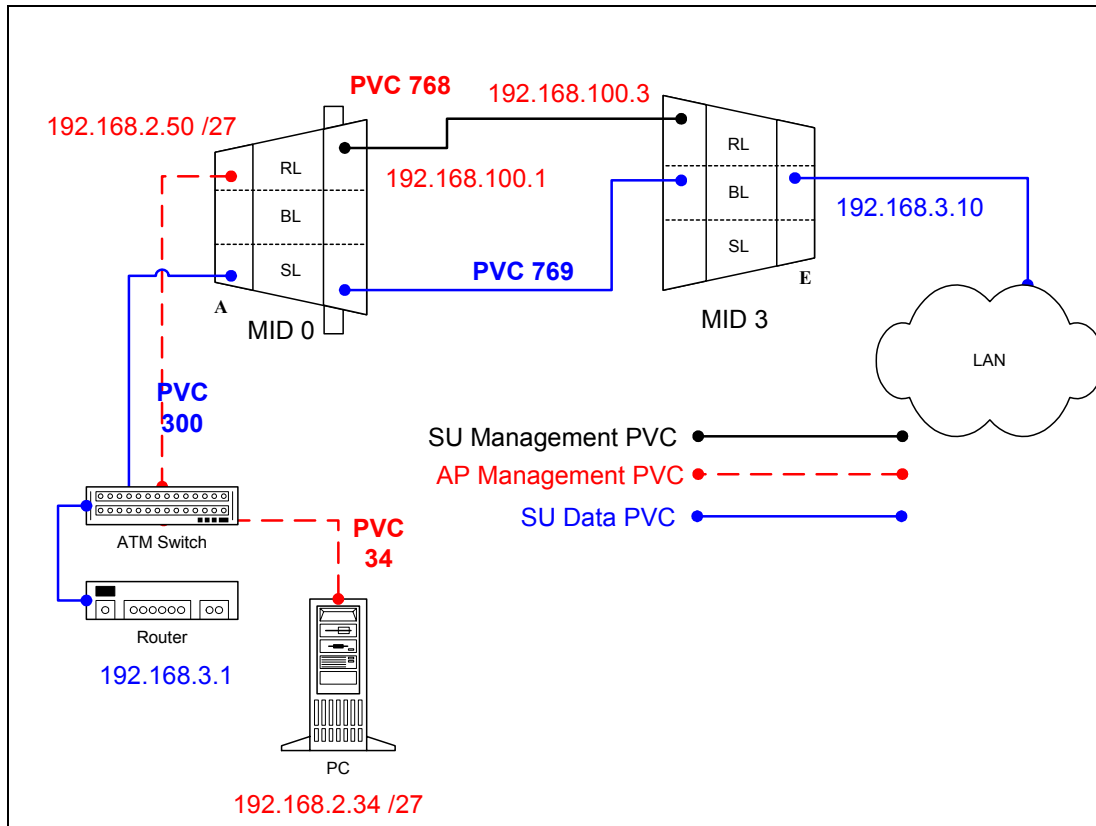

10.2.1 Routed Management PRO/CON

1483_S can be configured with switched management or routed management. Read PRO/CON of both to help you decide which you would like use.

PRO

- Only one ATMARP entry will need to be added to the termination router.
- Can be easier to troubleshoot and isolate a problem in the network.

CON

- Need to add a route and ipatm pvc for every SU that is added to the AP.
- May need to add a route to multiple routers for each SU depending upon network design.

10.2.2 AP Configuration Files

10.2.2.1 AP resolve

```
device add atm0 atm //bun mtu 1500 192.168.2.50
device add atm1 atm //bun mtu 1500 192.168.100.1

subnet add atm0.home . 192.168.2.32 ff:ff:ff:e0
subnet add atm1.home . 192.168.100.0 ff:ff:ff:00

route add default 0.0.0.0 192.168.2.34 00:00:00:00 1 # MAN

relay all

ipatm lifetime 60

ipatm pvc atm0 atm25i 0/34 pcr 70000/70000 remoteip 192.168.2.34
ipatm pvc atm1 atm25m 0/768 pcr 70000/70000 remoteip 192.168.100.3
```

10.2.2.2 AP system.conf

```
channel 0
antenna horizontal
mode static
mid 0
bid 0
interface atm0
backoff 0
provider abw
key Axxcelera
mask 1fff
leds active
max_mid 254
```

10.2.2.3 AP initswitchcli

```
tp default UBR 70000
```

```
sp default 256 stats
```

```
add atm25m 0 769 atm25i 0 300 default default perm epd
```

```
add atm25i 0 300 atm25m 0 769 default default perm epd
```

10.2.3 SU Configuration Files**10.2.3.1 SU resolve**

```
device add bridge ether //bridge mtu 1500 192.168.3.10
```

```
device add atm1 atm //bun mtu 1500 192.168.100.3
```

```
subnet add bridge.home . 192.168.3.0 ff:ff:ff:00
```

```
subnet add atm1.home . 192.168.100.0 ff:ff:ff:00
```

```
rip send all none
```

```
rip accept all none
```

```
route add default 0.0.0.0 192.168.3.1 00:00:00:00 1 # MAN
```

```
route add mgmt 192.168.2.32 192.168.100.1 ff:ff:ff:e0 1 # MAN
```

```
relay all
```

```
ipatm lifetime 60
```

```
ipatm pvc atm1 atm25m 0/768 pcr 70000/70000 remoteip 192.168.100.1
```

10.2.3.2 SU initbridge

```
spanning disable
```

```
device add edd
```

```
device add r1483
```

10.2.3.3 SU system.conf

```
channel 0
antenna horizontal
mode static
mid 3
bid 0
interface eth0
backoff 0
provider abw
key Axxcelera
mask 1ffff
leds active
```

10.2.3.4 SU in1483

```
pvc 0/769 atm25m 70000 70000
```

10.2.4 Troubleshooting

10.2.4.1 Can't ping the radio from the terrestrial interface

AP

1. Check all physical connections. It is a straight cable from the CS to the Switch, and a rollover twist from the wallbox to the switch (1-7,2-8).

2. Check to see if your atmarp entries are in the ARP table on the CS (./atmarp if you are already in the /usr/local/sbin directory).

- Add an atmarp entry
root@cs1 11:11:14 (4) [~]# atmarp -s 192.168.2.50 0.0.340
- View an atmarp table

```

root@cs1 11:12:52 (5) [~] # atmarp -a
----- If 0 (192.168.2.1, netmask 255.255.255.0) -----
Default QOS: ubr,aal5:max_sdu=9188
IP 192.168.2.50, state VALID, addr <none>, flags 0x4<PERM>
0.0.34
----- Unknown incoming connections -----
----- Incoming unidirectional connections -----
----- End of dump -----

```

- Delete an atmarp entry

```
root@cs1 11:13:42 (6) [~] # atmarp -d 192.168.2.50
```

3. Check route on CS, by typing route at the Command line.

- Add a route

```
root@cs1 11:17:19 (8) [~] # route add -net 192.168.100.0 netmask 255.255.255.0 gw 192.168.2.50
```

- View the routing table

```

root@cs1 11:18:51 (9) [~] # route
Kernel IP routing table
Destination Gateway Genmask Flags Metric Ref Use Iface
10.9.144.1 * 255.255.255.255 UH 0 0 0 eth0
192.168.100.0 192.168.2.50 255.255.255.0 UG 0 0 0 atm0
192.168.2.0 * 255.255.255.0 U 0 0 0 atm0
10.9.144.0 * 255.255.255.0 U 0 0 0 eth0
127.0.0.0 * 255.0.0.0 U 0 0 0 lo

```

- Delete a route

```
root@cs1 11:20:26 (10) [~] # route del -net 192.168.100.0 netmask 255.255.255.0
```

4. Check the Switch for the correct PVC's.

- Log into the ATM switch and check that the PVCs are mapped correctly. The following commands are for an FVC switch.
 - Add a PVC

```
ADMIN Access_NGI>set pvc add 101 0 34 be 102 0 34 be
```

```
Adding PVC i=101/0/34 o=102/0/34 to switch fabric
Updating FLASH memory. Please wait ... Done.
```

- Show the PVCs mapped in the switch

```
ADMIN Access_NGI> show pvc list id 0
```

```
-----
PVC ID IPort IVPI IVCI BW OPort OVPI OVCI BW
-----
      1  101  0   34  0  102  0   34  0
```

- Delete a PVC

```
ADMIN Access_NGI> set pvc del 1
```

SU

1. Check all physical connections. The radio is a network device, which means if you connect it to a PC (NIC) you will use a straight cable. If you connect the radio to a network device (hub, switch, router) you will use a Ethernet cross-over cable(1-3, 2-6). It is also important to check that the cable is punched down correctly in the wall box and the cable is terminated correctly at the radio. The termination at the radio uses 568B (wo,o,wg,bl,wbl,g,wbr,br).

2. Make sure the computer you are pinging from is on the same network as the AP. If you are on a different network than the radio make sure you have the proper routes in the radio and the computer you are trying to ping from.

10.2.4.2 Can't ping the radio across the wireless link.

There can be numerous reasons why you can't ping across the wireless link. After following these troubleshooting steps and you still can't ping across the wireless link refer to the RF troubleshooting document.

1. Check that SU has the proper MID.

```
192.168.3.10 hmm> system mid
MID 3
```

2. Check the ipatm pvc is correct in relation to the MID and remoteip

AP

```
192.168.2.50 ip> ipatm pvc  
ipatm pvc atm1 atm25m 0/768 pcr 70000/70000 remoteip 192.168.100.3
```

SU

```
192.168.3.65 ip> ipatm pvc  
ipatm pvc atm1 atm25m 0/768 pcr 70000/70000 remoteip 192.168.100.1
```

3. Check the default route in the SU.

```
192.168.3.65 ip> route  
route add default 0.0.0.0 192.168.100.1 00:00:00:00 1 # MAN via atm1
```

10.3 Static 1483_S (switched management)

All assumptions for troubleshooting 1483_S are based on the following diagram.

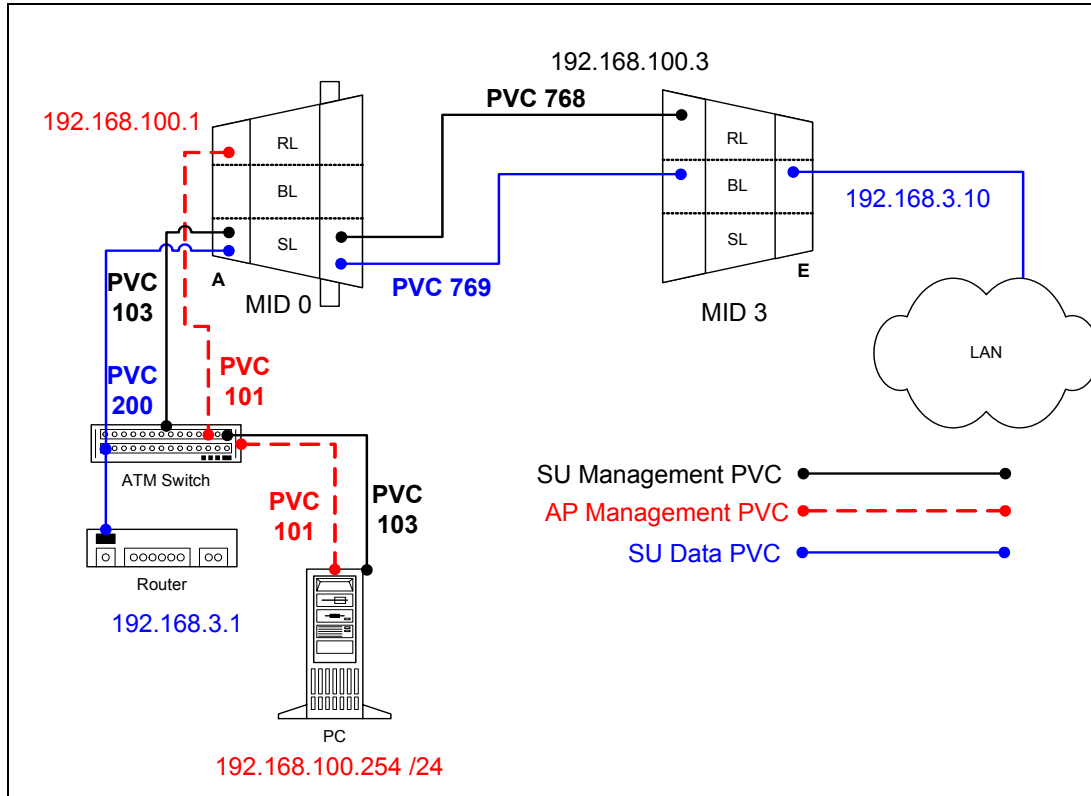

10.3.1 Switched Management PRO/CON

CLIP_S can be configured with switched management or routed management. Read PRO/CON of both to help you decide which you would like use.

PRO

- No extra mgmt routes will have to be added to the termination router.
- Multiple routes will not have to be added to network routers with the addition of each SU.

CON

- Will need to add an atmarp entry for each SU in the termination router.
- Will need to add a management PVC in the switchcli of the AP for each SU.

10.3.2 AP Configuration Files

10.3.2.1 AP resolve

```
device add atm0 atm //bun mtu 1500 192.168.100.1
subnet add atm0.home . 192.168.100.0 ff:ff:ff:00
route add default 0.0.0.0 192.168.100.254 00:00:00:00 1 # MAN
relay all
ipatm lifetime 60
ipatm pvc atm0 atm25i 0/101 pcr 70000/70000 remoteip 192.168.100.254
```

10.3.2.2 AP system.conf

```
channel 0
antenna horizontal
mode static
mid 0
bid 0
interface atm0
backoff 0
provider abw
key Axxcelera
mask 1fff
leds active
max_mid 254
```

10.3.2.3 AP initswitchcli

```
tp default UBR 70000
sp default 256 stats
add atm25m 0 768 atm25i 0 103 default default perm epd
add atm25i 0 103 atm25m 0 768 default default perm epd
add atm25m 0 769 atm25i 0 200 default default perm epd
add atm25i 0 200 atm25m 0 769 default default perm epd
```

10.3.3 SU Configuration Files

10.3.3.1 SU resolve

```
device add bridge ether //bridge mtu 1500 192.168.3.10
device add atm1 atm //bun mtu 1500 192.168.100.3

subnet add bridge.home . 192.168.3.0 ff:ff:ff:00
subnet add atm1.home . 192.168.100.0 ff:ff:ff:00

rip send all none
rip accept all none

route add default 0.0.0.0 192.168.3.1 00:00:00:00 1 # MAN
relay all
ipatm lifetime 60
ipatm pvc atm1 atm25m 0/768 pcr 70000/70000 remoteip 192.168.100.254
```

10.3.3.2 SU initbridge

```
spanning disable
device add edd
device add r1483
```

10.3.3.3 SU system.conf

```
channel 0
antenna horizontal
mode static
mid 3
bid 0
interface eth0
backoff 0
provider abw
key Axxcelera
mask 1ffff
leds active
```

10.3.3.4 SU in1483

```
pvc 0/769 atm25m 70000 70000
```

10.3.4 Troubleshooting**10.3.4.1 Can't ping the radio from the terrestrial interface**

AP

1. Check all physical connections. It is a straight cable from the CS to the Switch, and a rollover twist from the wall box to the switch (1-7,2-8).
2. Check to see if your atmarp entries are in the ARP table on the CS. (./atmarp if you are already in the /usr/local/sbin directory)

- Add an atmarp entry

```
root@cs1 11:11:14 (4) [~] # atmarp -s 192.168.100.1 0.0.101
```

- View an atmarp table

```
root@cs1 11:12:52 (5) [~] # atmarp -a
---- If 0 (192.168.100.254, netmask 255.255.255.0) ----
Default QOS: ubr,aal5:max_sdu=9188
IP 192.168.100.1, state VALID, addr <none>, flags 0x4<PERM> 0.0.101
---- Unknown incoming connections ----
---- Incoming unidirectional connections ----
---- End of dump ----
```

- Delete an atmarp entry
root@cs1 11:13:42 (6) [~] # atmarp -d 192.168.100.1

3. Check the Switch for the correct PVC's.

- Log into the ATM switch and check that the PVCs are mapped correctly. The following commands are for an FVC switch.

- Add a PVC

```
ADMIN Access_NGI>set pvc add 101 0 101 be 102 0 101 be
```

```
Adding PVC i=101/0/34 o=102/0/34 to switch fabric
Updating FLASH memory. Please wait ... Done.
```

- Show the PVCs mapped in the switch

```
ADMIN Access_NGI>show pvc list id 0
```

```
-----
PVC ID IPort IVPI IVCI BW OPort OVPI OVCI BW
-----
      1  101  0   101  0   102  0   101  0
```

- Delete a PVC

```
ADMIN Access_NGI>set pvc del 1
```

SU

1. Check all physical connections. The radio is a network device, which means if you connect it to a PC (NIC) you will use a straight cable. If you connect the radio to a network device (hub, switch, router) you will use a Ethernet cross-over cable(1-3, 2-6). It is also important to check that the cable is punched down correctly in the wall box and the cable is terminated correctly at the radio. The termination at the radio uses 568B (wo,o,wg,bl,wbl,g,wbr,br).

2. Make sure the computer you are pinging from is on the same network as the AP. If you are on a different network than the radio make sure you have the proper routes in the radio and the computer you are trying to ping from.

10.3.4.2 Can't ping across the wireless link

There are numerous reason why you couldn't ping across the wireless link. After following these troubleshooting steps and you still can't ping across the wireless link refer to the RF troubleshooting document.

1. Check that SU has the proper MID.

```
192.168.3.10 hmm> system mid
MID 3
```

2. Check the that the pvc information is correct in relation to the MID and remoteip

AP

```
192.168.100.254 switchcli> list all all perm
```

Displaying permanent entries for all ports.

port	vp	vc	port	vp	vc
atm25i	0	103 ==>	atm25m	0	768
atm25m	0	768 ==>	atm25i	0	103
atm25i	0	200 ==>	atm25m	0	769
atm25m	0	769 ==>	atm25i	0	200

SU

```
192.168.3.65 ip> ipatm pvc
ipatm pvc atm1 atm25m 0/768 pcr 70000/70000 remoteip 192.168.100.1
```

3. Check the default route in the SU.

```
192.168.3.65 ip> route
route add default 0.0.0.0 192.168.100.254 00:00:00:00 1 # MAN via atm1
```

11 Native ATM

In this configuration the AP and the SU act as an ATM switch. Both AP and SU will pass any ATM cells without looking at upper level protocols.

11.1 Static Native ATM

All assumptions for troubleshooting Native ATM are based on the following diagram.

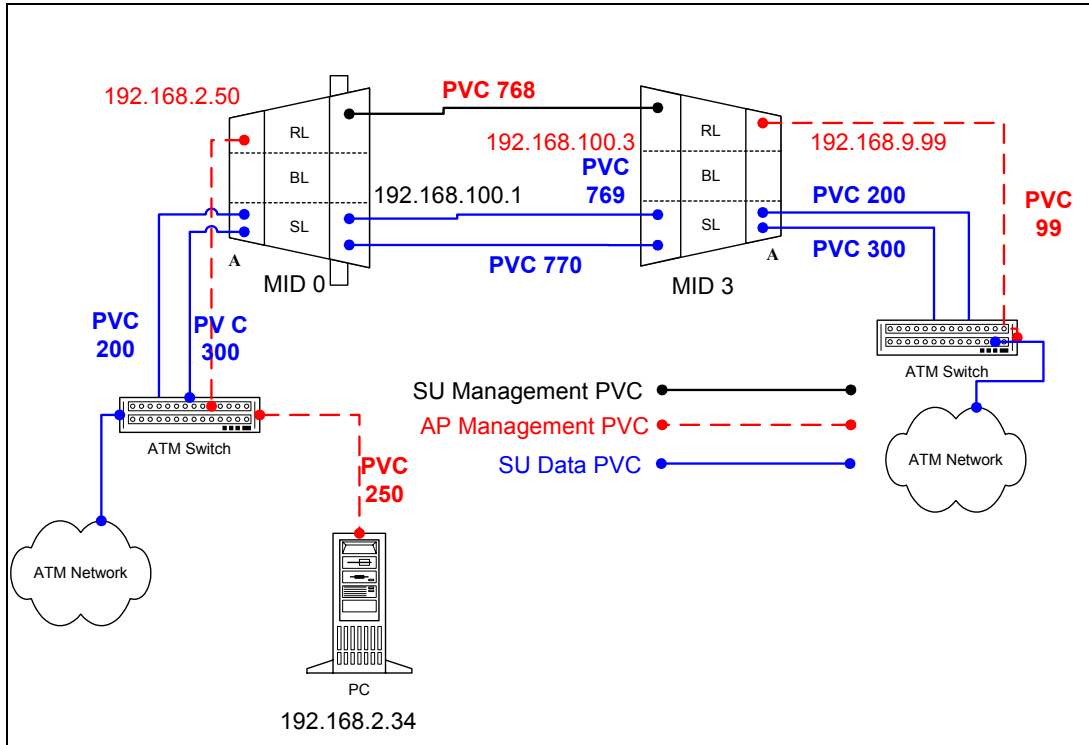

11.1.1 AP Configuration Files

11.1.1.1 AP resolve

```
device add atm0 atm //bun mtu 1500 192.168.2.50
device add atm1 atm //bun mtu 1500 192.168.100.1

subnet add atm0.home . 192.168.2.0 ff:ff:ff:00
subnet add atm1.home . 192.168.100.0 ff:ff:ff:00

rip send all none
rip accept all none

route add default 0.0.0.0 192.168.2.34 00:00:00:00 1 # MAN

relay all

ipatm lifetime 60
ipatm pvc atm0 atm25i 0/250 pcr 70000/70000 remoteip 192.168.2.34
ipatm pvc atm1 atm25m 0/768 pcr 70000/70000 remoteip 192.168.100.3
```

11.1.1.2 AP system.conf

```
channel 0
antenna horizontal
mode static
mid 0
bid 0
interface atm0
backoff 0
provider abw
key Axxcelera
mask 1ffff
leds active
```

11.1.1.3 AP initswitchcli

```
tp default UBR 70000
sp default 256 stats

add atm25m 0 769 atm25i 0 200 default default perm epd
add atm25i 0 200 atm25m 0 769 default default perm epd

add atm25i 0 300 atm25m 0 770 default default perm epd
add atm25m 0 770 atm25i 0 300 default default perm epd
```

11.1.2 SU Configuration Files**11.1.2.1 SU resolve**

```
device add atm0 atm //bun mtu 1500 192.168.9.99
device add atm1 atm //bun mtu 1500 192.168.100.3

subnet add atm1.home . 192.168.100.0 ff:ff:ff:00
subnet add atm0.home . 192.168.9.0 ff:ff:ff:00

rip send all none
rip accept all none

route add default 0.0.0.0 192.168.100.1 00:00:00:00 1 # MAN
relay all

ipatm lifetime 60
ipatm pvc atm0 atm25i 0/99 pcr 70000/70000 remoteip 192.168.9.1
ipatm pvc atm1 atm25m 0/768 pcr 70000/70000 remoteip 192.168.100.1
```

11.1.2.2 SU system.conf

```
channel 0
antenna horizontal
mode static
mid 3
bid 0
interface atm0
backoff 0
provider abw
key Axxcelera
mask 1ffff
leds active
```

11.1.2.3 SU initswitchcli

```
tp default UBR 70000
sp default 256 stats
add atm25m 0 769 atm25i 0 200 default default perm epd
add atm25i 0 200 atm25m 0 769 default default perm epd

add atm25i 0 300 atm25m 0 770 default default perm epd
add atm25m 0 770 atm25i 0 300 default default perm epd
```

11.1.3 Troubleshooting

11.1.3.1 Can't ping the radio from the terrestrial interface

AP

1. Check all physical connections. It is a straight cable from the CS to the Switch, and a rollover twist from the wallbox to the switch (1-7,2-8).

2. Check to see if your atmarp entries are in the ARP table on the CS. (./atmarp if you are already in the /usr/local/sbin directory)

- Add an atmarp entry

```
root@cs1 11:11:14 (4) [~]# atmarp -s 192.168.2.50 0.0.250
```

- View an atmarp table

```
root@cs1 11:12:52 (5) [~] # atmarp -a
----- If 0 (192.168.2.1, netmask 255.255.255.0) -----
Default QOS: ubr,aal5:max_sdu=9188
IP 192.168.2.50, state VALID, addr <none>, flags 0x4<PERM>
0.0.250
----- Unknown incoming connections -----
----- Incoming unidirectional connections -----
----- End of dump -----
```

- Delete an atmarp entry

```
root@cs1 11:13:42 (6) [~] # atmarp -d 192.168.2.50
```

3. Check route on CS, by typing route at the Command line.

- Add a route

```
root@cs1 11:17:19 (8) [~] # route add -net 192.168.100.0 netmask 255.255.255.0 gw 192.168.2.50
```

- View the routing table

```
root@cs1 11:18:51 (9) [~] # route
Kernel IP routing table
Destination Gateway Genmask Flags Metric Ref Use Iface
10.9.144.1 * 255.255.255.255 UH 0 0 0 eth0
192.168.100.0 192.168.2.50 255.255.255.0 UG 0 0 0 atm0
192.168.2.0 * 255.255.255.0 U 0 0 0 atm0
192.168.2.0 * 255.255.255.0 U 0 0 0 atm0
10.9.144.0 * 255.255.255.0 U 0 0 0 eth0
127.0.0.0 * 255.0.0.0 U 0 0 0 lo
```

- Delete a route

```
root@cs1 11:20:26 (10) [~] # route del -net 192.168.100.0 netmask 255.255.255.0
```

4. Check the Switch for the correct PVC's.

- Log into the ATM switch and check that the PVCs are mapped correctly. The following commands are for an FVC switch.

- Add a PVC

```
ADMIN Access_NGI>set pvc add 101 0 250 be 102 0 250 be
```

```
Adding PVC i=101/0/250 o=102/0/250 to switch fabric
Updating FLASH memory. Please wait ... Done.
```

- Show the PVCs mapped in the switch

```
ADMIN Access_NGI> show pvc list id 0
```

```
-----
PVC ID IPort IVPI IVCI BW OPort OVPI OVCI BW
-----
      1  101  0   250  0   102  0   250  0
```

- Delete a PVC

```
ADMIN Access_NGI> set pvc del 1
```

SU

1. Check all physical connections. The radio is a network device, which means if you connect it to a PC (NIC) you will use a straight cable. If you connect the radio to a network device (hub, switch, router) you will use a Ethernet cross-over cable(1-3, 2-6). It is also important to check that the cable is punched down correctly in the wall box and the cable is terminated correctly at the radio. The termination at the radio uses 568B (wo,o,wg,bl,wbl,g,wbr,br).

2. Make sure the computer you are pinging from is on the same network as the AP. If you are on a different network than the radio make sure you have the proper routes in the radio and the computer you are trying to ping from.

11.1.3.2 Can't ping the radio across the wireless link.

There can be numerous reasons why you can't ping across the wireless link. After following these troubleshooting steps and you still can't ping across the wireless link refer to the RF troubleshooting document.

1. Check that SU has the proper MID.

```
192.168.3.10 hmm> system mid
MID 3
```

2. Check the ipatm pvc is correct in relation to the MID and remoteip

AP

```
192.168.2.50 ip> ipatm pvc  
ipatm pvc atm1 atm25m 0/768 pcr 70000/70000 remoteip 192.168.100.3
```

SU

```
192.168.3.65 ip> ipatm pvc  
ipatm pvc atm1 atm25m 0/768 pcr 70000/70000 remoteip 192.168.100.1
```

3. Check the default route in the SU.

```
192.168.3.65 ip> route  
route add default 0.0.0.0 192.168.100.1 00:00:00:00 1 # MAN via atm1
```

12 Extender

The Extender (PTP) units operate in the same manner as the AB-Access (PMP) units.

The Ethernet Extender configuration and operation are almost identical to the 1483_T configuration except they use a single port bridge which is more efficient.

The ATM Extender configuration and operation is identical to the Native_ATM configuration, where as the AP and the SU act as an ATM switch. Both AP and SU will pass any ATM cells without looking at upper level protocols.

BHM = Backhaul Master

BHS = Backhaul Slave

12.1 Ethernet Extender

All assumptions for troubleshooting the Ethernet Extender are based on the following diagram.

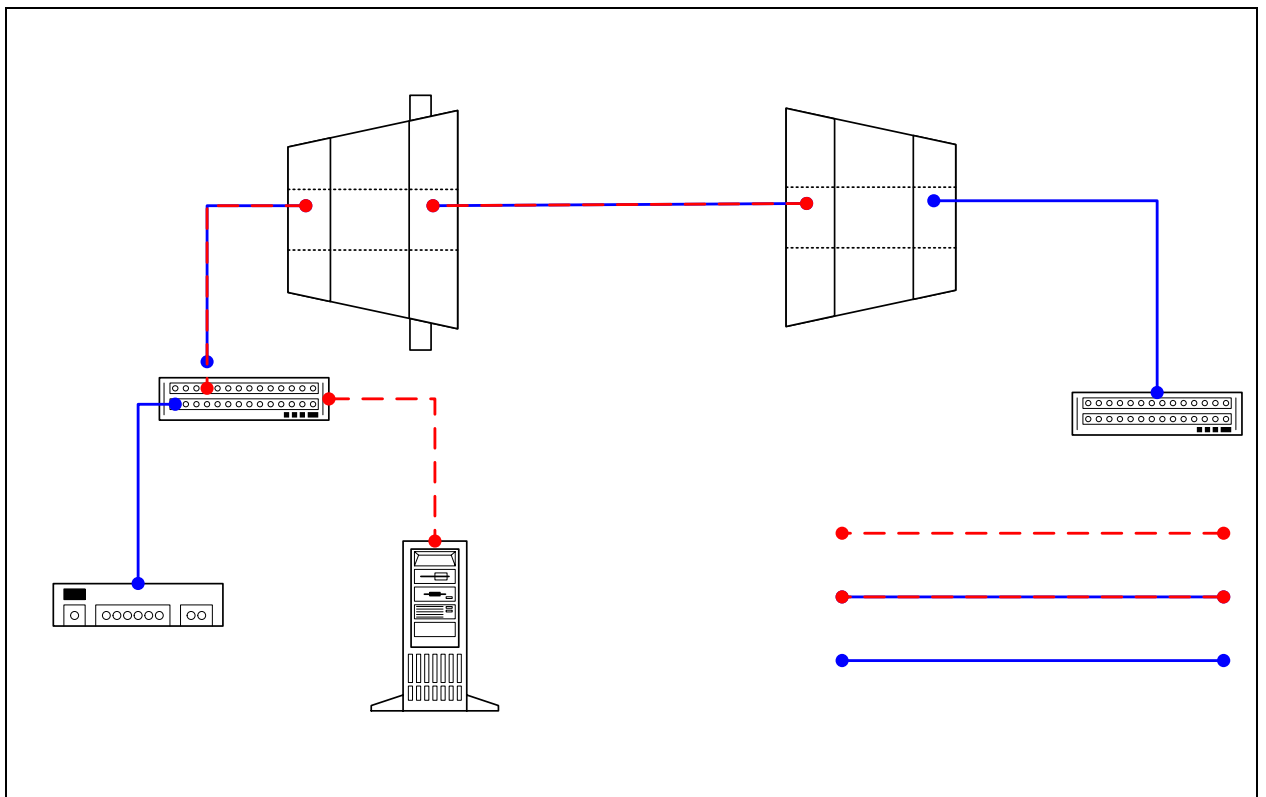

12.1.1 BHM Configuration Files

12.1.1.1 BHM resolve

```
device add bridge ether //bridge mtu 1500 192.168.3.9
subnet add bridge.home . 192.168.3.0 ff:ff:ff:00
rip send all none
rip accept all none
route add default 0.0.0.0 192.168.3.1 00:00:00:00 1 # MAN
relay all
ipatm lifetime 60
```

12.1.1.2 BHM initbridge

```
spanning disable
device add edd
device add r1483
```

12.1.1.3 BHM initr1483

```
pvc 0/768 atm25m 70000 70000
```

12.1.1.4 BHM system.conf

```
channel 0
antenna horizontal
mode static
mid 0
bid 0
interface eth0
backoff 0
provider abw
key Axxcelera
mask 1fff
leds active
max_mid 254
```

12.1.2 BHS Configuration Files

12.1.2.1 BHS resolve

```
device add bridge ether //bridge mtu 1500 192.168.3.10
subnet add bridge.home . 192.168.3.0 ff:ff:ff:00
rip send all none
rip accept all none
route add default 0.0.0.0 192.168.3.1 00:00:00:00 1 # MAN
relay all
ipatm lifetime 60
```

12.1.2.2 BHS initbridge

```
spanning disable
device add edd
device add r1483
```

12.1.2.3 BHS system.conf

```
channel 0
antenna horizontal
mode static
mid 3
bid 0
interface eth0
backoff 0
provider abw
key Axxcelera
mask 1ffff
leds active
```

12.1.2.4 BHS initr1483

```
pvc 0/768 atm25m 70000 70000
```

12.1.3 Troubleshooting

12.1.3.1 Can't ping the radio from the terrestrial interface.

1. Check all physical connections. The radio is a network device, which means if you connect it to a PC (NIC) you will use a straight cable. If you connect the radio to a network device (hub, switch, router) you will use a Ethernet cross-over cable(1-3, 2-6). It is also important to check that the cable is punched down correctly in the wall box and the cable is terminated correctly at the radio. The termination at the radio uses 568B (wo,o,wg,bl,wbl,g,wbr,br).

2. Make sure the computer you are pinging from is on the same network as the AP. If you are on a different network than the radio make sure you have the proper routes in the radio and the computer you are trying to ping from.

12.1.3.2 Can't ping the radio across the wireless link.

There can be numerous reasons why you can't ping across the wireless link. After following these troubleshooting steps and you still can't ping across the wireless link refer to the RF troubleshooting document.

1. Check the 1483 processes in the radios. Make sure they are active and have the correct PVC mapped.

```
BHM (r1483 command)
192.168.3.9 > r1483 pvc
Active PVC: 3/768
Active port: atm25m
```

```
BHS (r1483 command)
192.168.3.10 > r1483 pvc
Active PVC: 0/768
Active port: atm25m
```

12.2 ATM Extender

All assumptions for troubleshooting the ATM Extender are based on the following diagram.

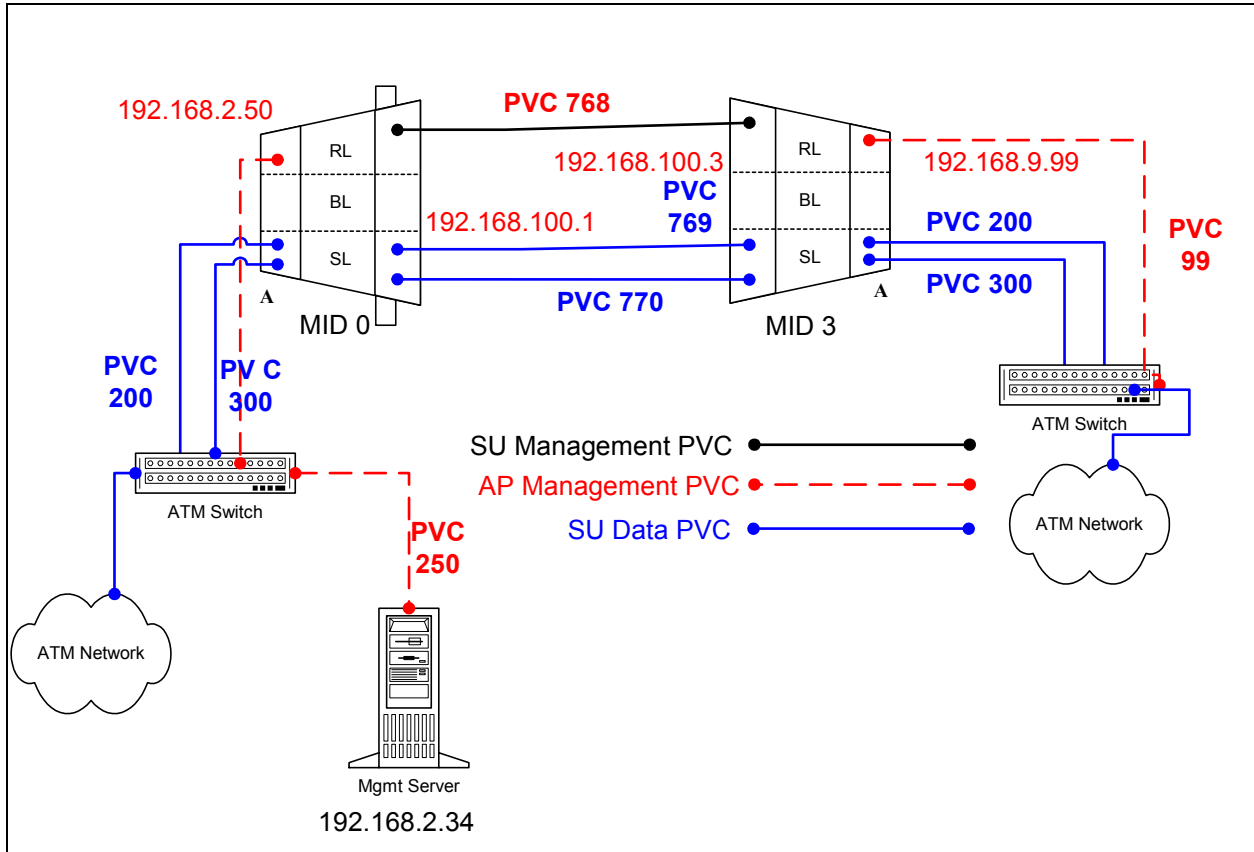

12.2.1 BHM Configuration Files

12.2.1.1 BHM resolve

```
device add atm0 atm //bun mtu 1500 192.168.2.50
device add atm1 atm //bun mtu 1500 192.168.100.1

subnet add atm0.home . 192.168.2.0 ff:ff:ff:00
subnet add atm1.home . 192.168.100.0 ff:ff:ff:00

rip send all none
rip accept all none

route add default 0.0.0.0 192.168.2.34 00:00:00:00 1 # MAN

relay all

ipatm lifetime 60
ipatm pvc atm0 atm25i 0/250 pcr 70000/70000 remoteip 192.168.2.34
ipatm pvc atm1 atm25m 0/768 pcr 70000/70000 remoteip 192.168.100.3
```

12.2.1.2 BHM system.conf

```
channel 0
antenna horizontal
mode static
mid 0
bid 0
interface atm0
backoff 0
provider abw
key Axxcelera
mask 1fff
leds active
```

12.2.1.3 BHM initswitchcli

```
tp default UBR 70000
sp default 256 stats

add atm25m 0 769 atm25i 0 200 default default perm epd
add atm25i 0 200 atm25m 0 769 default default perm epd

add atm25i 0 300 atm25m 0 770 default default perm epd
add atm25m 0 770 atm25i 0 300 default default perm epd
```

12.2.2 BHS Configuration Files

12.2.2.1 BHS resolve

```
device add atm0 atm //bun mtu 1500 192.168.9.99
device add atm1 atm //bun mtu 1500 192.168.100.3

subnet add atm1.home . 192.168.100.0 ff:ff:ff:00
subnet add atm0.home . 192.168.9.0 ff:ff:ff:00

rip send all none
rip accept all none

route add default 0.0.0.0 192.168.100.1 00:00:00:00 1 # MAN
relay all

ipatm lifetime 60
ipatm pvc atm0 atm25i 0/99 pcr 70000/70000 remoteip 192.168.9.1
ipatm pvc atm1 atm25m 0/768 pcr 70000/70000 remoteip 192.168.100.1
```

12.2.2.2 BHS system.conf

```
channel 0
antenna horizontal
mode static
mid 3
bid 0
interface atm0
backoff 0
provider abw
key Axxcelera
mask 1ffff
leds debug
```

12.2.2.3 BHS initswitchcli

```
tp default UBR 70000
sp default 256 stats
add atm25m 0 769 atm25i 0 200 default default perm epd
add atm25i 0 200 atm25m 0 769 default default perm epd

add atm25i 0 300 atm25m 0 770 default default perm epd
add atm25m 0 770 atm25i 0 300 default default perm epd
```

12.2.3 Troubleshooting**12.2.3.1 Can't ping the radio from the terrestrial interface**

AP

1. Check all physical connections. It is a straight cable from the CS to the Switch, and a rollover twist from the wallbox to the switch (1-7,2-8).

2. Check to see if your atmarp entries are in the ARP table on the CS. (./atmarp if you are already in the /usr/local/sbin directory)

- Add an atmarp entry

```
root@cs1 11:11:14 (4) [~]# atmarp -s 192.168.2.50 0.0.250
```

- View an atmarp table

```
root@cs1 11:12:52 (5) [~] # atmarp -a
----- If 0 (192.168.2.1, netmask 255.255.255.0) -----
Default QOS: ubr,aal5:max_sdu=9188
IP 192.168.2.50, state VALID, addr <none>, flags 0x4<PERM>
0.0.250
----- Unknown incoming connections -----
----- Incoming unidirectional connections -----
----- End of dump -----
```

- Delete an atmarp entry

```
root@cs1 11:13:42 (6) [~] # atmarp -d 192.168.2.50
```

3. Check route on CS, by typing route at the Command line.

- Add a route

```
root@cs1 11:17:19 (8) [~] # route add -net 192.168.100.0 netmask 255.255.255.0 gw 192.168.2.50
```

- View the routing table

```
root@cs1 11:18:51 (9) [~] # route
Kernel IP routing table
Destination Gateway Genmask Flags Metric Ref Use Iface
10.9.144.1 * 255.255.255.255 UH 0 0 0 eth0
192.168.100.0 192.168.2.50 255.255.255.0 UG 0 0 0 atm0
192.168.2.0 * 255.255.255.0 U 0 0 0 atm0
192.168.2.0 * 255.255.255.0 U 0 0 0 atm0
10.9.144.0 * 255.255.255.0 U 0 0 0 eth0
127.0.0.0 * 255.0.0.0 U 0 0 0 lo
```

- Delete a route

```
root@cs1 11:20:26 (10) [~] # route del -net 192.168.100.0 netmask 255.255.255.0
```

4. Check the Switch for the correct PVC's.

- Log into the ATM switch and check that the PVCs are mapped correctly. The following commands are for an FVC switch.

- Add a PVC

```
ADMIN Access_NGI>set pvc add 101 0 250 be 102 0 250 be
```

```
Adding PVC i=101/0/250 o=102/0/250 to switch fabric
Updating FLASH memory. Please wait ... Done.
```

- Show the PVCs mapped in the switch

```
ADMIN Access_NGI> show pvc list id 0
```

```
-----
PVC ID IPort IVPI IVCI BW OPort OVPI OVCI BW
-----
      1  101  0   250  0  102  0   250  0
```

- Delete a PVC

```
ADMIN Access_NGI> set pvc del 1
```

SU

1. Check all physical connections. The radio is a network device, which means if you connect it to a PC (NIC) you will use a straight cable. If you connect the radio to a network device (hub, switch, router) you will use a Ethernet cross-over cable(1-3, 2-6). It is also important to check that the cable is punched down correctly in the wall box and the cable is terminated correctly at the radio. The termination at the radio uses 568B (wo,o,wg,bl,wbl,g,wbr,br).

2. Make sure the computer you are pinging from is on the same network as the AP. If you are on a different network than the radio make sure you have the proper routes in the radio and the computer you are trying to ping from.

12.2.3.2 Can't ping the radio across the wireless link.

There can be numerous reasons why you can't ping across the wireless link. After following these troubleshooting steps and you still can't ping across the wireless link refer to the RF troubleshooting document.

1. Check that SU has the proper MID.

```
192.168.3.10 hmm> system mid
MID 3
```

2. Check the ipatm pvc is correct in relation to the MID and remoteip

AP

```
192.168.2.50 ip> ipatm pvc  
ipatm pvc atm1 atm25m 0/768 pcr 70000/70000 remoteip 192.168.100.3
```

SU

```
192.168.3.65 ip> ipatm pvc  
ipatm pvc atm1 atm25m 0/768 pcr 70000/70000 remoteip 192.168.100.1
```

3. Check the default route in the SU.

```
192.168.3.65 ip> route  
route add default 0.0.0.0 192.168.100.1 00:00:00:00 1 # MAN via atm1
```

13 RF Design and Planning

13.1 Overview

The AB-Access system is a communications system using wireless technology in the U-NII & ISM frequency bands. Therefore understanding Radio Frequency (RF) system design is necessary to ensure good link quality and, thus, good system performance. This section discusses the basics of RF Design and Planning from the perspective of deploying the AB-Access System.

13.2 The U-NII & ISM Channel Plan

In 1997 the FCC amended its Part 15 rules to make 300 MHz of spectrum available for high-speed wireless digital communications with unlicensed operation. This band, called the Unlicensed National Information Infrastructure or U-NII band, provides the spectrum at 5.15 to 5.25 GHz for indoor use, and 5.25 to 5.35 and 5.725 to 5.825 GHz for outdoor use. The peak output power permitted is limited to 23 dBm EIRP in the lower (indoor) band, 30 dBm in the mid-band, and 36 dBm in the upper band.

The 5.8 GHz ISM (Industrial Scientific and Medical) band ranges from 5.725-5.850 GHz. Which is an unlicensed frequency limited to 36 dBm for PTMP equipment. The limit for PTP is higher than PTMP.

NOTE: AB-Access uses both the U-NII and ISM band for its upper band channels.

NOTE: BPSK modulation is only approved by the FCC for the upper band channels.

13.3 Air Interface

The SU talks to the AP over a proprietary airlink protocol on a single 15 MHz channel using QPSK or BPSK modulation and a technique called Time Division Duplex (TDD). Both upstream and downstream traffic time-share this channel.

13.4 Wireless MAC

When data is sent over the wireless link it must first be put into a structure that each end unit will understand. The hardware that does this is called the MAC (Medium Access Controller).

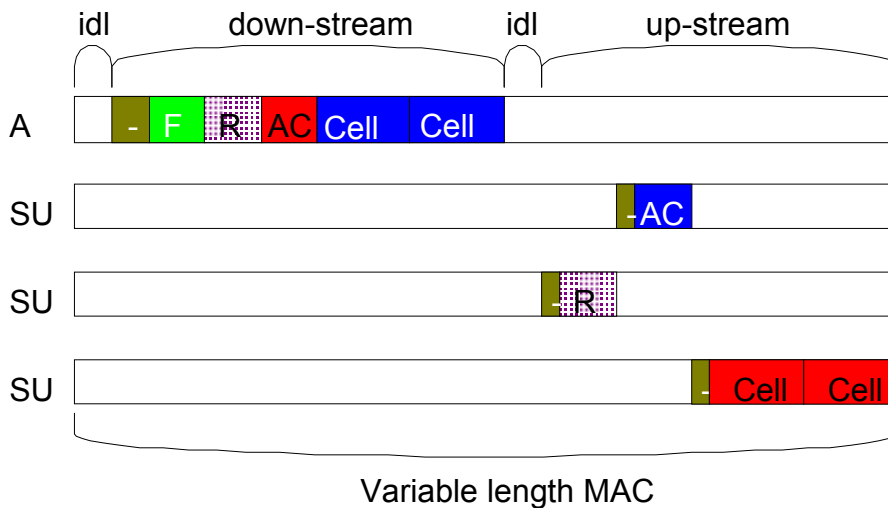

ATT	FDHDR	RG	DACK	DCELL	STT	RR	UACK	UCELL/ UCELLR
-----	-------	----	------	-------	-----	----	------	------------------

13.4.1 Downstream burst

13.4.1.1 Access Point Turnaround Time (ATT)

AB-Access system is TDD (Time Division Duplexing), meaning that the AP and SUs transmit and receive on the same frequency. It is therefore necessary to have a small delay between the transmit and receive processes, because it is using the same hardware to perform both functions.

13.4.1.2 Frame Descriptor Header (FDHDR)

Downstream bursts begin with a Frame Descriptor Header (FDHDR) this portion of the MAC frame is seen by all SUs in that sector. The FDHDR contains a map of all traffic upstream and downstream, to occur within the MAC frame. This is why you assign a unit a MID, when an SU sees an FDHDR it looks for its MID in the FDHDR to see if it is going to receive any cells. If it does not see its MID it will ignore the rest of the frame.

13.4.1.3 Reservation Grant (RG)

The next field in the downstream burst is the Reservation Grant Response (RGR). An RGR is a response to an Reservation Grant Request (Upstream Burst). The RGR acknowledges a request and tells the SU that it can transmit on the upstream burst.

13.4.1.4 Downstream Acknowledgement (DACK)

The Downstream Acknowledgement (DACK) is an acknowledgement sent from the AP, which contains bit maps corresponding to the success or failure of individual cells sent to an SU in the previous frame. If any cells were missed or dropped they will be resent in the next frame.

13.4.1.5 Downstream Data Cells (DCELL)

The Data Cells are the actual ATM cells that contain data. The maximum ATM cells per frame are 32. The maximum ATM cells that can be sent to an individual SU is 6 per frame.

13.4.1.6 Subscriber Turnaround Time (STT)

AB-Access system is TDD (Time Division Duplexing), meaning that the AP and SUs transmit and receive on the same frequency. It is therefore necessary to have a small delay between transmit and receive processes, because it is using the same hardware to perform both functions. There is also a set delay for each individual SU. This delay in turnaround is to compensate for propagation delay.

13.4.1.7 Reservation Request (RR)

The Reservation Grant Request (RR) is a request sent by the SU to the AP when it has data to send. The RGR is a contention based request, meaning it performs like an Ethernet network where there is no guarantee that it will be received by the AP on the first try. This would happen when another SU wants to transmit at the same time and would cause a collision. If a collision occurs the SU will try again until it is acknowledged with a Reservation Grant Response.

13.4.1.8 Upstream Acknowledgement (UACK)

The Upstream Acknowledgement (UACK) contains bit maps corresponding to the success or failure of individual cells from an AP. If any cells were missed or dropped they will be resent in the next frame.

13.4.1.9 Upstream Cell (UCCELL/UCCELLR)

The UCCELL's are the actual ATM cells that contain data. The maximum ATM cells per frame are 32. The maximum ATM cells that can be sent to an AP by an individual SU is 6 per frame. The UCCELLR is a data cell that also has a Reservation Grant Request if the SU has more than 6 data cells to send. The reason for this is so that the SU doesn't have to contend for another Reservation Grant in the contention slot.

13.5 Delay Compensation

During the upstream portion of the MAC several SUs transmit in sequence. Since SUs are separated from the AP by anywhere from 0m to 16km, there is a wide range of propagation times for the full path for the AP to the SUs and back. In order for the SUs transmissions to

arrive at the AP properly aligned, some active compensation of propagation delay is performed. An SU must delay compensate before it can transmit data, if it was allowed to transmit without delay compensating it would confuse the AP because it would be receiving cells out of order.

As you can see in this diagram the dark green portion of the MAC frame represent time delays.

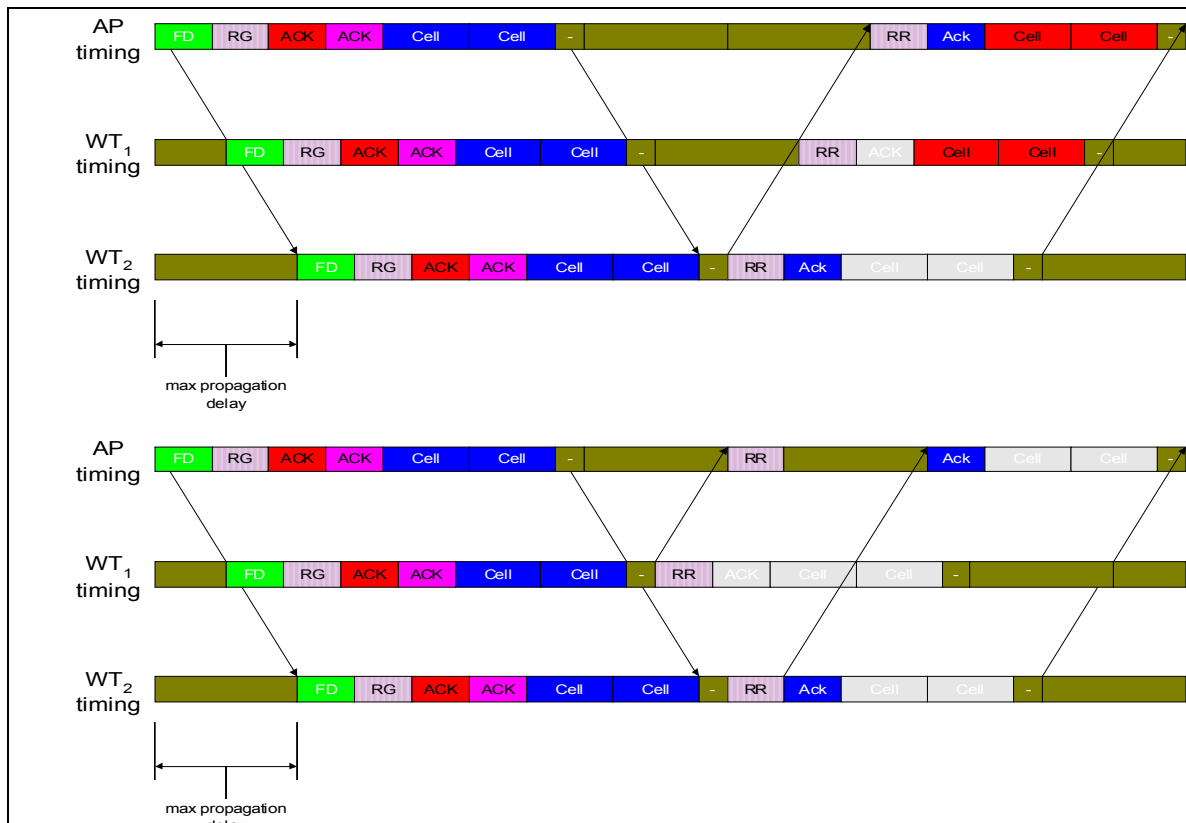

13.6 RF Channels spacing and output power

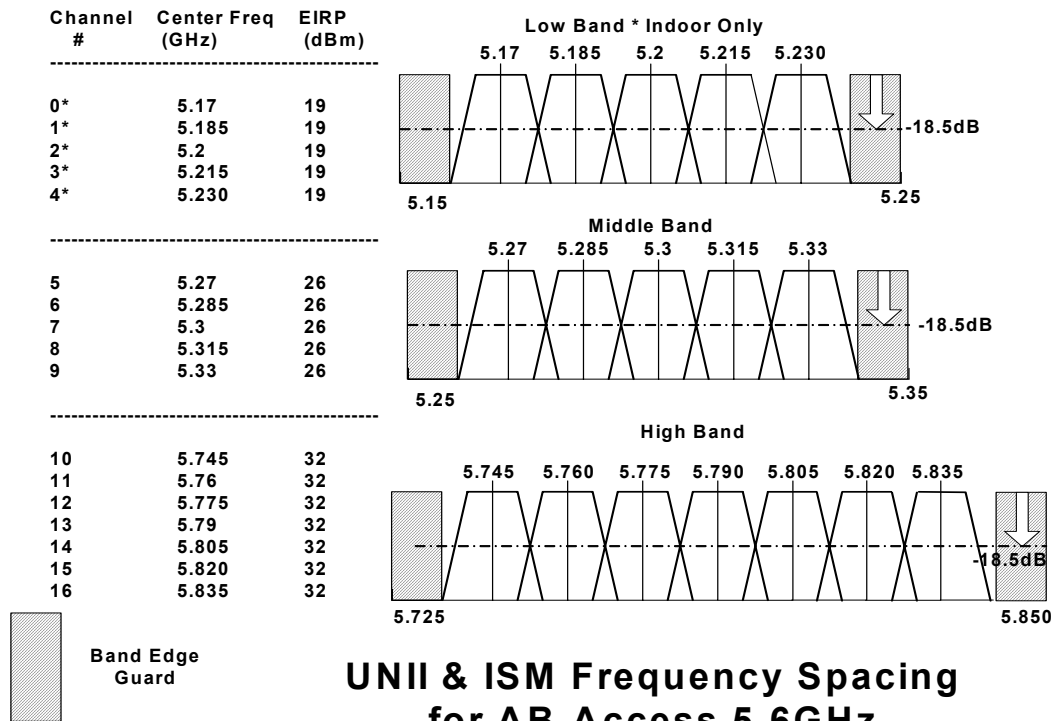

UNII & ISM Frequency Spacing for AB-Access 5-6GHz

13.7 TDD (Time Division Duplex)

The AB-Access system uses TDD (Time Division Duplex) to transfer data across the wireless link as opposed to FDD (Frequency Division Duplex). The AB-Access implementation of the TDD architecture allows the TDD frame to dynamically vary in size according to the offered load: short frames when fewer users are sharing the channel, longer frames when there are many simultaneous users. The TDD guard time is also adaptive, as it is set to round trip propagation delay to the farthest SU. TDD has a number of advantages over a FDD system. These include:

- **Spectral Efficiency** – TDD can be deployed using less spectrum than a comparable FDD system. A single TDD channel can be deployed per sector instead of two channels needed for FDD. Likewise, a multi-cell deployment can be installed using a total of three RF channels (both polarizations), whereas FDD needs four to six channels.
- **Complexity** – Since each transceiver is wither transmitting or receiving, but never both at once, a single RF front end can be shared reducing the radio complexity.
- **Power Control** – In cellular systems, where channels are reused many times throughout the system in order to increase capacity, the highest efficiency is realized when the power in each direction can be minimized. This reduces the amount of

energy that is ‘leaked’ into surrounding areas, which appears as interference. In FDD systems, it is quite difficult to accurately control the channel’s power since a feedback path is required. No such path is needed in a TDD system since the same channel is used in both directions. The SU needs to only measure the received power from the AP in order to know how much to attenuate its upstream transmission.

- **Channel Efficiency** – Because each frame carries upstream and downstream traffic in proportion to the offered load in each direction, adaptive TDD systems are highly efficient in its use of bandwidth. FDD systems have to make an estimate of the traffic mixture and allocate channel bandwidth accordingly. As shown in the chart below, any variation from this estimate (in this case 15:1 downlink) will result in wasted bandwidth. This variation is inevitable due to the diurnal variation of business usage during the daytime hours, residential usage in the afternoon and evening, a varying mixture of user types according to the geographic location, and an ever-changing set of user applications.

13.8 AP and SU Specifications

13.8.1 AP/SU/Extender Functional Block Diagram

The Access Point and Subscriber Unit functional block diagram is shown below. The analog radio portion is highlighted in blue, while the digital section containing the modem is in yellow.

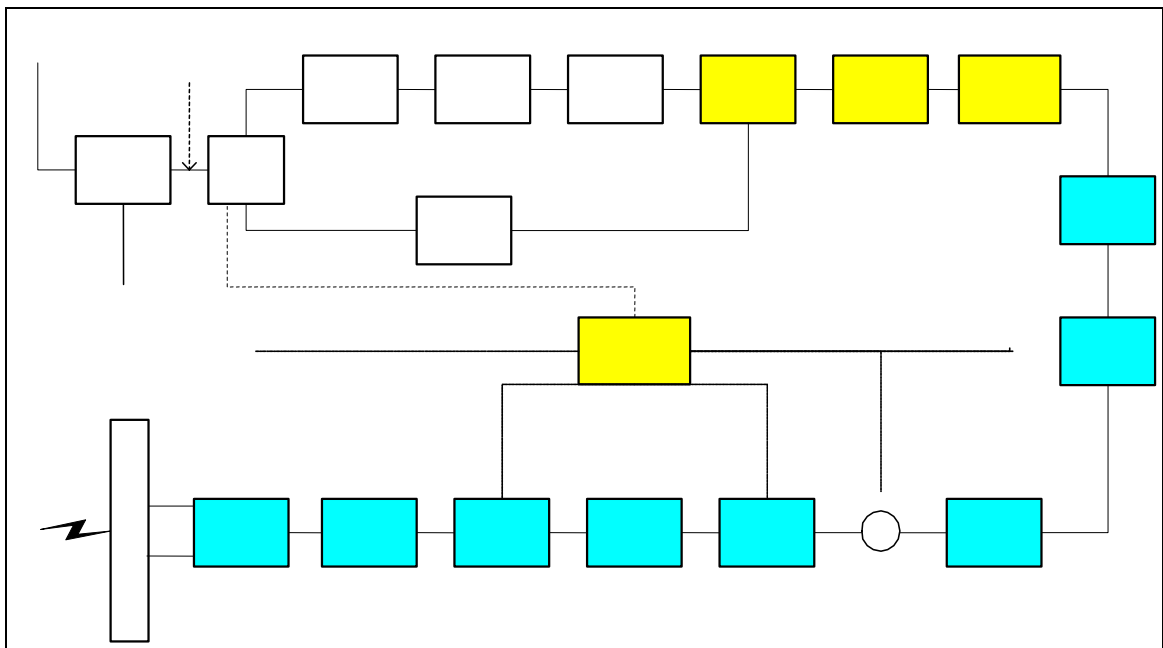

13.8.2 Radio Specifications

This table represents the radio specifications for AP, SU, and Extender units.

Frequency of operation	5.150GHz to 5.350GHz & 5.725GHz to 5.850 GHz
RF bandwidth	325 MHz
Channelization	15 MHz
FCC 26 dB Bandwidth	17.5 MHz (assumes QPSK with Raised Cosine Filtering, $\alpha=0.35$) typical
Output Power into antenna	Lower-band 1 dBm (include 3.5 dB backoff, max) Mid-band 8 dBm (includes 3.5 dB backoff, max) Upper-band 14 dBm (5.6km units) (includes 3.5 dB backoff, max) Upper –band 16 dBm (8.0km units)(includes 3.5 backoff, max)
Spurious emissions	-17 dBm/MHz within 10 MHz of upper band (max) -27 dBm/MHz beyond 10 MHz of upper band (max)
Blocking rejection	60 dB fc \pm 50 MHz to \pm 100 MHz (min) 70 dB fc + 100 MHz to 8 GHz (min) 70 dB fc 100 MHz to 4 GHz (min) 80 dB DC to 4 GHz and 7 to 12 GHz (min)
U-NII & ISM band blocking level	-41 dBm
Adjacent channel rejection	-25 dB (min)
Receiver noise figure	-7 dB (max)
Sensitivity	-81.6 dBm for 10^{-4} demodulated BER
AGC range	55 dB
AGC accuracy	± 1 dB
AGC response time	<200 ns
Transmit / receive switching time	<5 μ s
Receive / transmit switching time	<2 μ s

Channel switching time	<100 μ s
Horizontal / Vertical antenna switching time	<5 μ s

13.8.3 Subscriber Unit Antenna

Peak gain	18 dBi
3 dB beamwidth	20° azimuth x 20° elevation
Front-to-back ratio	30 dB (min)
Sidelobe suppression	15 dB (min)
Input impedance	50 ohms
Polarization	Linear – vertical or horizontal switchable
VSWR	2:1 (max)

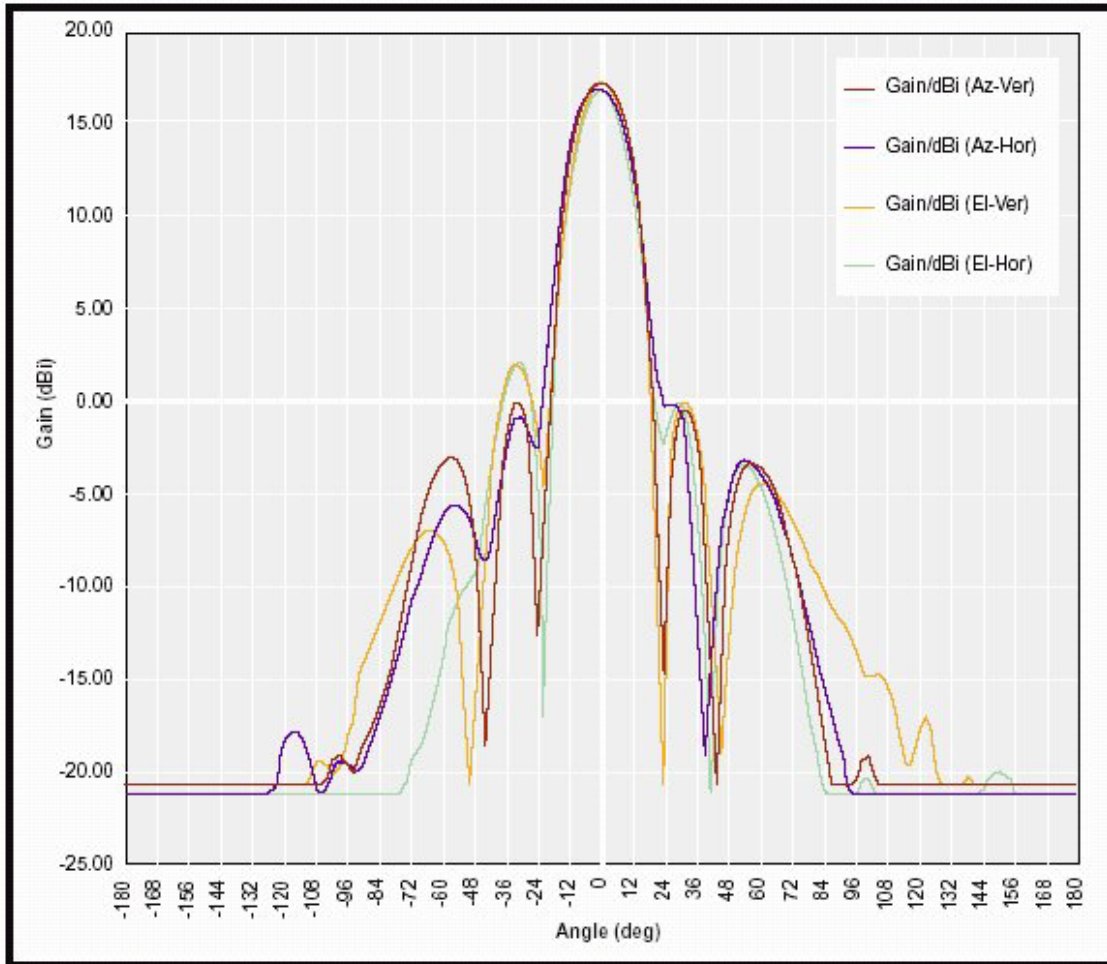

13.8.4 Access Point Antenna

Peak gain	18 dBi
3 dB beamwidth	60° azimuth x 7° elevation
Front-to-back ratio	25 dB (min)
Sidelobe suppression	15 dB (min)
Input impedance	50 ¾ ohms
Polarization	Linear – vertical or horizontal switchable
VSWR	2:1 (max)

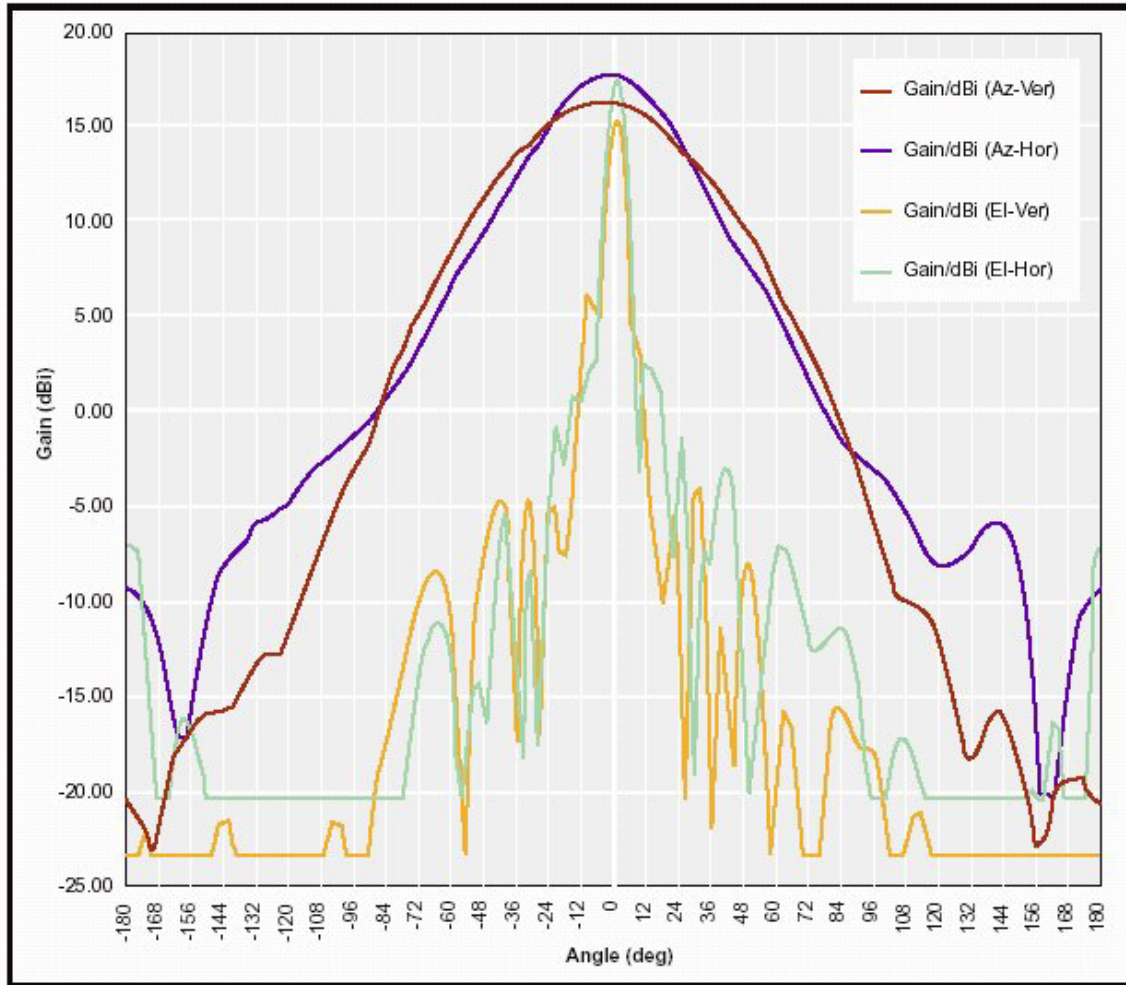

13.8.5 Extender Antenna

Peak gain	23 dBi
3 dB beamwidth	10° azimuth x 10° elevation
Front-to-back ratio	25 dB (min)
Sidelobe suppression	15 dB (min)
Input impedance	50 ¾ ohms
Polarization	Linear – vertical or horizontal switchable
VSWR	2:1 (max)

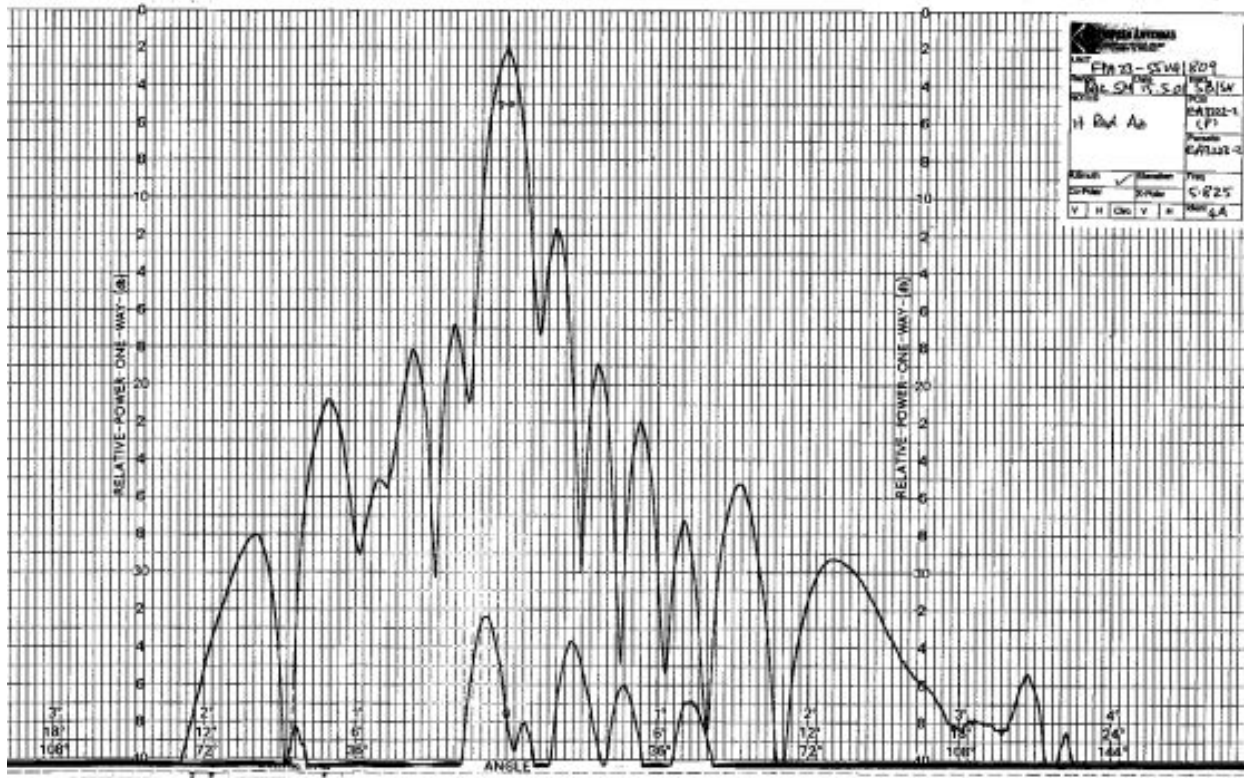

13.9 Topology Types

To properly deploy the AB-Access System, one must understand the geographical physical topology. While the real world possibilities are endless, the following three distinctive geographic topologies will be covered:

- Macrocells
- Microcells
- Picocells

A Macrocell design should be used when you are trying to provide ubiquitous coverage over a large area. Each cell has many Subscribers. The fundamental limit in deploying in this manner is usually coverage zone (cell radius) due to U-NII & ISM EIRP limits, as well as building and terrain obstructions.

A Microcell is normally used when you are trying to provide high density coverage to a smaller geographic area. Each cell sector has many subscribers per sector. The fundamental limit in deploying in this manner is co-channel interference due to LOS interference paths.

A Picocell design normally covers an extremely small geographic area such as a neighbourhood or a Multiple Dwelling Unit (MDU) complex. There are normally

many sectors and few subscribers per sector. The fundamental limit in deploying in this manner is Line of Sight (LOS) coverage.

While the above are generalizations, they can be used effectively as a starting point for developing an RF plan for deployment. However, based upon the specifications of the AB-Access equipment, it is necessary to have some pre-defined RF coloring schemes. To better understand the benefits of different coloring schemes, a basic concept of interference types should be understood.

13.10 Interference Types

There are four distinct types of interference that can occur in a cellular reuse pattern. Each unique in its geometry and imposes unique frequency reuse constraints.

EFFECT	INTERFERENCE TYPE
Would affect only the one SU. Could affect other units if they are in the same area.	Type 1 – Downlink Downlink to Subscriber Unit Interfered with by another Access Point transmission.
Would affect only the one SU. Could affect other units if they are in the same area.	Type 2 – Downlink Downlink to Subscriber Unit Interfered with by a Subscriber Unit Uplink in another cell.
Would affect all units in the sector. This would be a constant source of interference.	Type 3 – Uplink Uplink to Access Point Interfered with by another Access Point transmission. Becomes critical if facets using same frequency face each other.
Would affect all units in the sector. Could be an intermittent problem based on the amount of data that interfering SU is transmitting.	Type 4 – Uplink Uplink to Access Point Interfered with by a Subscriber Unit uplink from another cell. Hardest to eliminate and will reduce the performance of the whole system.

13.10.1 Type 1 Interference

Downlink to Subscriber Unit interfered with by another Access Point Downlink. All Access Points power control for full service at the sector edge (in cusp). The worst case scenario is when the SU (Cell 1) has the interfering AP at Boresight (Cell 2) and is towards the edge of its sector, i.e. min CNR from its AP.

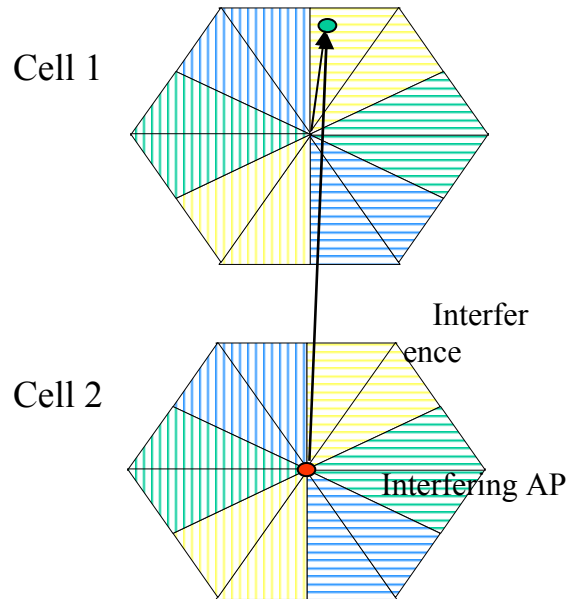

13.10.2 Type 2 Interference

Downlink to Subscriber Unit interfered with by a Subscriber Unit Uplink in another cell. Worst case scenario is interfering SU at range (max Tx power), and victim SU at range (lowest CNR) and SUs facing each other, e.g. Cells 1 and 3. The interference is reduced if SUs using the same frequencies do not face each other, e.g., Cells 1 and 2.

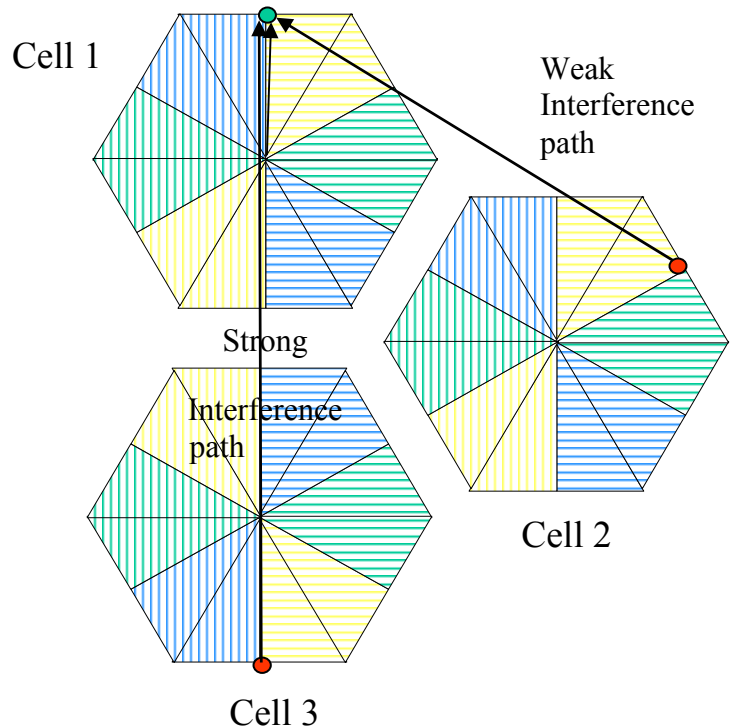

13.10.3 Type 3 Interference

Uplink to Access Point interfered with by another Access Point Downlink. This is only an issue if sectors using the same frequency face each other in the reuse pattern, e.g., Cell 1 and Cell 3. Otherwise it is a benign interference type, e.g., Cell 1 and Cell 2.

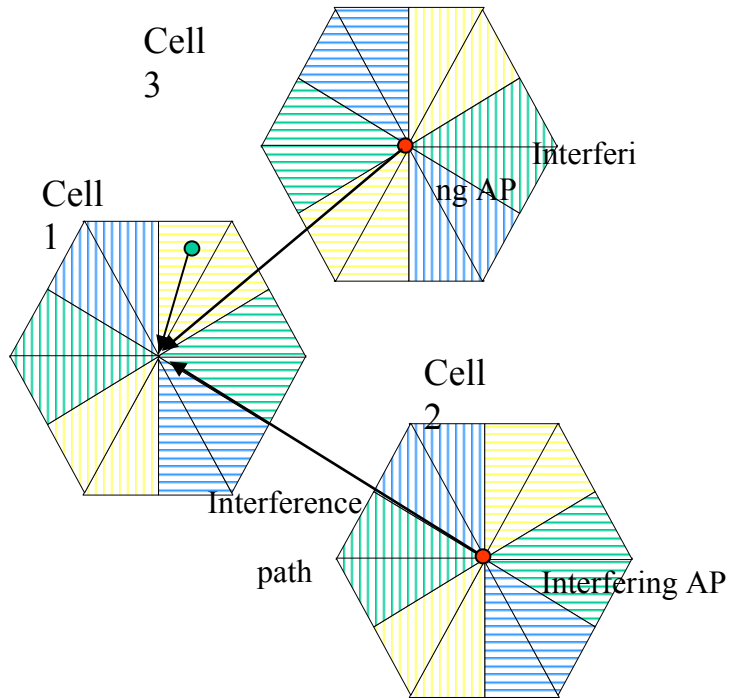

13.10.4 Type 4 Interference

Uplink to Access Point interfered with by a Subscriber Unit Uplink in another cell. This is the worst case of intercell interference, as one SU, e.g., in Cell 2, interferes with all the users on the same frequency and polarization in Cell 1 (whenever the SU in Cell 2 is transmitting). As the system has power control for SUs, the worst case Type 4 interference will be caused by SUs deployed at range and at the edge of their sector, i.e., in the Access Point Antenna Cusp.

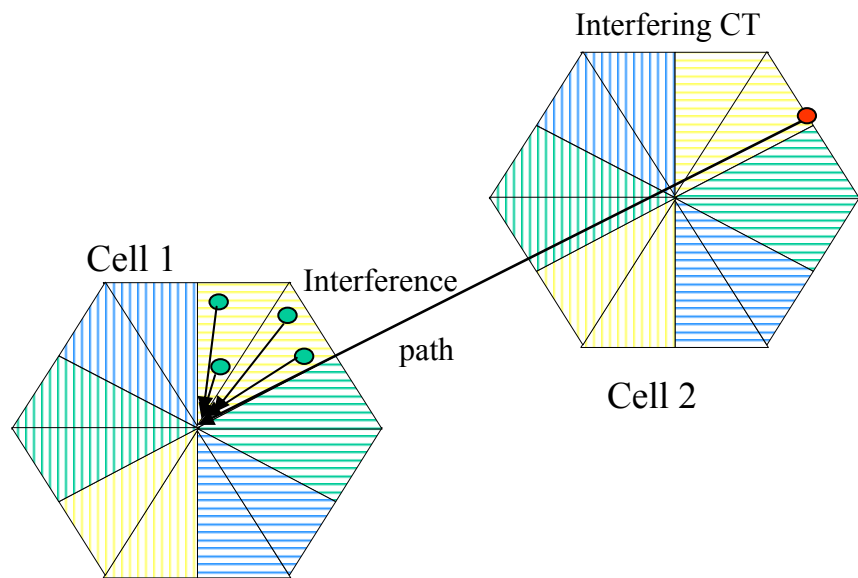

13.11 Recommended Channel Plans

The following sections will describe some pre-defined coloring schemes that will work in the U-NII & ISM band with the AB-Access equipment.

13.11.1 Six-Sector, Three-Frequency Plan

This plan is good for Macrocells on relatively flat terrain:

- Use 1 channel guardband/separation between sectors
- Use opposite polarization in opposite directions
- Use 4 meter back-to-back separation (or equivalent isolation)
- Use >1 meter separation between sectors
- Use same frequencies and sector allocations in each cell.

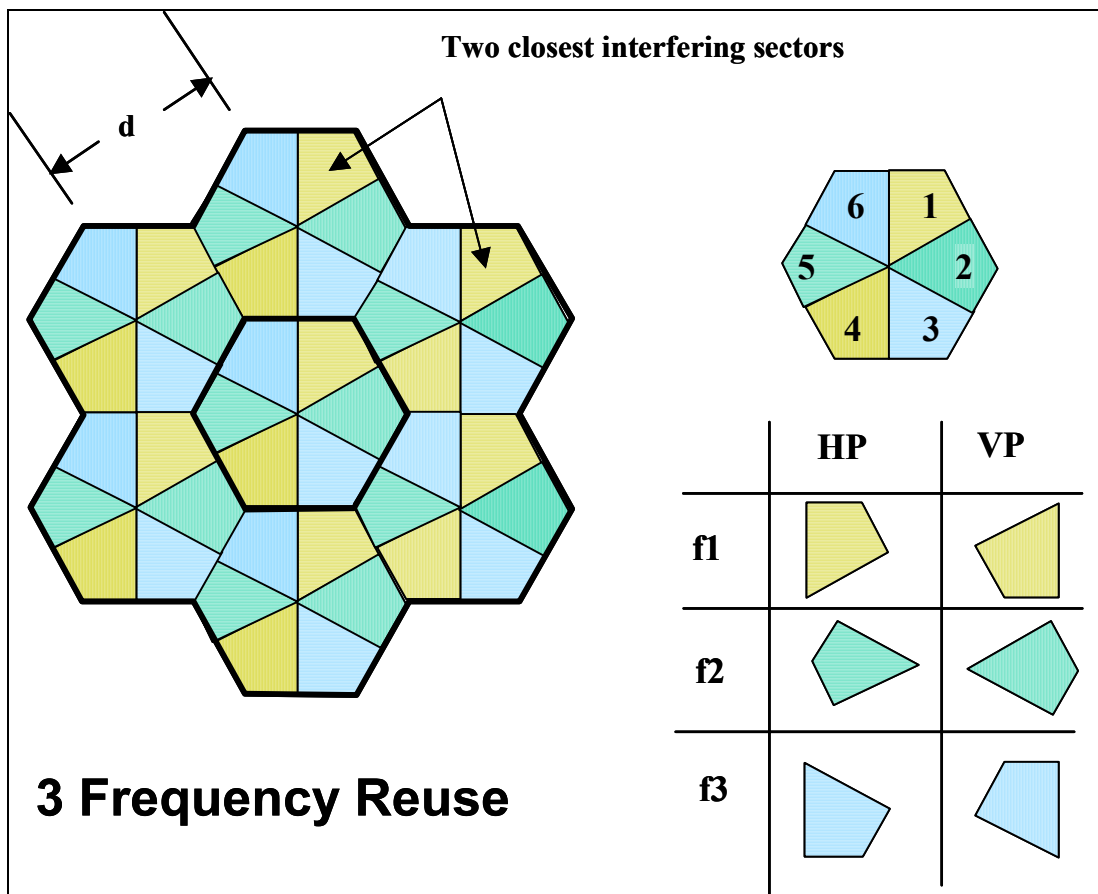

13.11.2 Six-Sector, Six-Frequency Plan

This plan is good for Microcells or Macrocells on uneven terrain:

- Use 1 channel guardband/separation between sectors
- Use opposite polarization in opposite directions
- Use 4 meter separation (or equivalent isolation)
- Use >1 meter separation between sectors
- Use a different set of three frequencies on alternating cells.

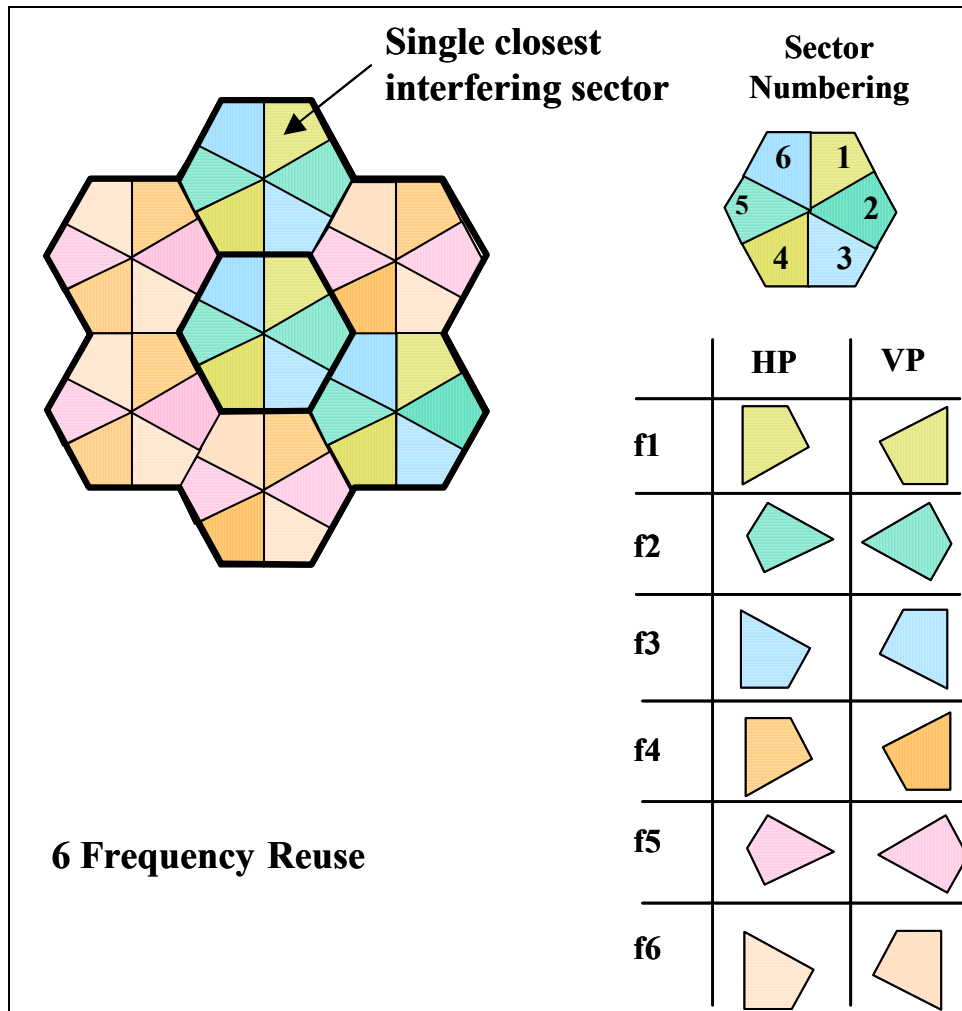

13.12 Antenna Spacing

In most Base Station deployments, multiple APs are placed on a single building or tower. To minimize AP to AP interference, it is necessary to mount the antennas with proper spacing. Based on the frequency plan identified, the following minimum spacing shown in the table below should be maintained.

	0 deg - Verticle		0 deg - Horizontal		60 deg		120 deg		180 deg	
Polarization	CO	OPP	CO	OPP	CO	OPP	CO	OPP	CO	OPP
Co-Channel	NA	NA	NA	NA	NA	NA	NA	NA	NA	4m
Adjacent Channel	NA	NA	NA	NA	NA	>8m+	1m	1m	1m	1m
2nd Adjacent	6"	6"	1m	1m	1m	1m	<1inch	<1inch	0.5m	0.5m

NA = Not acceptable

14 SNMP

SNMP access has been added to AB-Access in software load 5.1.x and newer. This allows you to monitor various parameters within the radio. Listed below are the non-standard MIB's added to AB-Access.

Object Name	Object Descriptor	AB-Access Info
snmpTotalSetVars	1.3.6.1.2.1.11.14	RSSI (only available on SU)
snmpOutSetRequests	1.3.6.1.2.1.11.27	PP processor loading (%)
snmpOutTooBigs	1.3.6.1.2.1.11.20	Channel Number
snmpOutNoSuchNames	1.3.6.1.2.1.11.9	Antenna polarization (0=H, 1=V)
snmpOutBadValues	1.3.6.1.2.1.11.22	SU distance from AP (meters)
snmpInSetRequests	1.3.6.1.2.1.11.17	# of ARP entries in the ARP table

15 Rupee

There are configurations that are not covered by the upgrade scripts. Even if they are covered, you will probably want to add settings that are specific to your network. To do this you can edit the individual files and rupee them to the units. **This is not meant to replace the upgrade script. It is only meant to send individual configuration files to a unit.**

You can send individual files from DOS or LINUX; unlike the upgrade scripts. The reason for this is that the upgrade script is using expect scripting and can only be run from a Unix based OS. One note about the rupee-dos is that it can only be run be a true DOS based OS (Win95 or Win98 not NT). NT uses a Virtual DOS Machine (NTVDM) and will not work with the rupee-dos command.

WARNING

If you rupee a file or files to a unit and do not reboot the unit, and then rupee another file or files to the unit only the last set of files will be saved to the flash.

15.1 LINUX

1. Make sure you can ping the unit that you want to send files to.
2. Change to the directory that the configuration files are in. The rupee-unix file must also reside in this directory.
3. To upload individual files:

```
./rupee-unix -p atmos -d 2 -r <IP Address> <file> <file>
```

Note: You might have to change the permissions on the rupee-unix command using “chmod”

```
chmod +x ./rupee-unix
```

15.2 DOS

1. Make sure you can ping the unit that you want to send files to.
2. Change to the directory that the configuration files are in. The rupee-unix file must also reside in this directory.
3. To upload individual files:

```
rupee-dos -p atmos -d 2 -r <IP Address> <file> <file>
```

15.3 Rupee Option Definitions

- p <passwd>** Specifies the password to use to allow write access to the AP/SU.
- d 2** Display debug level 2. Allows you to see what is being sent to the unit.
- r** Reboot unit when done programming. Make sure all of your configuration files are correct if you use this option. When the unit reboots, changes are final.

16 RTFD (Return To Factory Default)

The new Return To Factory Default (RTFD) feature allows IP connectivity to be established with units that have unknown or invalid configurations. Using this feature, the AB-Access unit will adopt a known IP configuration enabling Command Line Interface access via telnet through the physical Ethernet interface.

Following a restart or power up, the AB-Access/AB-Extender units will listen for 1 second for a proprietary coded UDP packet on their Ethernet interface; adopting the appropriate IP configurations as indicated below.

If the unit receives the UDP packet, it will retain the active configuration for 30 minutes, after which the normal start-up procedures will continue with the IP and interface configuration taken from the unit's Flash files. If during the 30 minute period, a subsequent coded UDP packet is received, the timeout will be restarted.

NOTE

On Windows 2K and XP you may need to disable the auto media sense. Some NICs will be capable of disabling this feature from their configuration parameters. If this option is not available on your NIC you will have to add a registry entry. Axxcelera has created a reg edit that can be installed by simply double clicking on the *media-sense.reg* file. Or you can enter the following register key via regedit.

[HKEY_LOCAL_MACHINE\SYSTEM\CurrentControlSet\Services\Tcpip\Parameters]

"DisableDHCPMediaSense"=dword:00000001

16.1 RTFD IP Configurations

Ethernet Interface Access:	IP Address	192.168.3.254
	Netmask	255.255.255.0
	Default Route	192.168.3.1

16.2 Recover

To supply the coded UDP packet the "recover" utility is provided with the system software in two forms.

recover-dos.exe - For use with a DOS prompt under Microsoft Windows.

Recover-unix - For use with Linux installations utilizing glibc 2.1.3.

16.3 Procedure to restore the default configuration

1. Connect a PC (Windows or Linux) to the wallbox of the unit, ensuring that there is appropriate connectivity at the physical and IP levels.
2. Start the recovery utility. A sequence of dots will be displayed to indicate successful network transmissions.

```
[root@temp SU_TEMPLATE]# ./recover-unix ethernet  
SU/AP recovery client
```

.....

3. Restart the AB-Access unit.
4. When the recover utility terminates, the AB-Access unit has been successfully configured and can be contacted over the physical interface via a telnet session.
5. It is best to do a full system upgrade after a unit has been recovered to a state that IP connectivity is regained. This will insure the unit will function properly once redeployed.

16.4 Disabling the RTFD Feature

RTFD can be disabled by writing a file to flash with the name “no_rtf”. The file must be a text file; i.e. only containing ASCII characters. A suggested first line for the file is “disable RTFD” – though the actual content of the file will not be referenced: only the presence or absence of the file is significant.