



ADAPTIVE BROADBAND[®]

**AB-ACCESS
SYSTEM**

U-NII PRODUCT INSTALLATION MANUAL

**for Subscriber Units, Base Stations, Access Points
and AB-Access Extender Units**

Internal DRAFT Copy

Document Number: ABA-U-NII-PIM-3 (part2 – chapters 7 to 11)

May 2001

SECTION 7

Subscriber Unit Installation

7 Subscriber Unit Installation

TBD: Update the figure numbers etc. in this section an onwards.

7.1 Installation Overview

The Subscriber Unit installation steps are as follows:

1. Install the mounting pole and mount the outdoor Subscriber Unit (see Figure 6-1).
2. Install the indoor junction box.
3. Route the interconnect cable. Connect it to the outdoor Subscriber Unit and the indoor junction box.
4. Ground both the outdoor Subscriber Unit and indoor junction box.
5. Perform initial startup and testing.

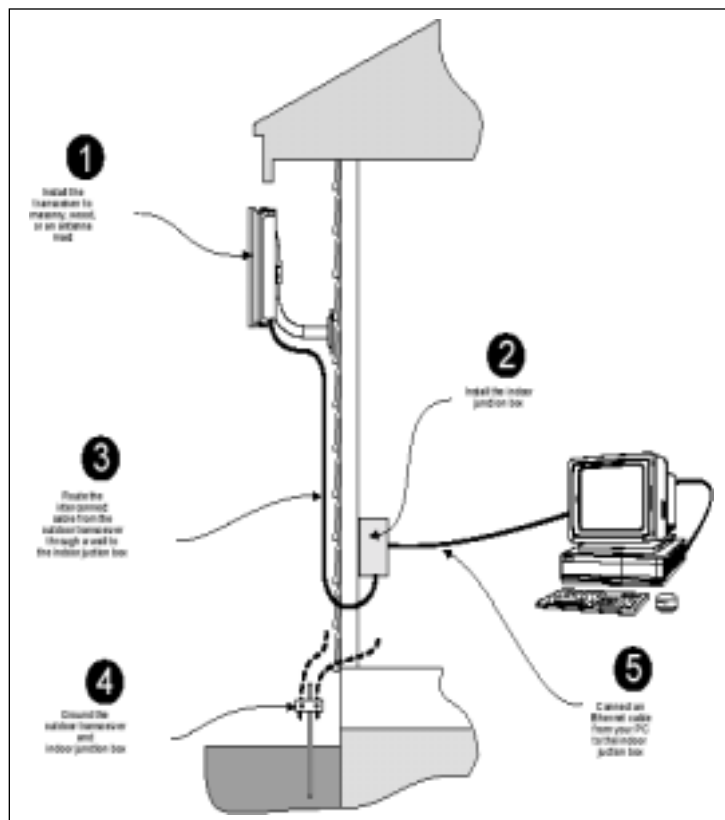

Figure 7-1 AB-Access Subscriber Unit Installation Overview

7.2 Installing Mounting Pole

Once you have selected a site for installing the outdoor transceiver/Subscriber Unit, determine what type of surface you will use for your installation. Select from the following list:

- *Installing on a Brick Or Masonry Wall*
- *Installing on a Wall With Wood Siding*
- *Installing on an Antenna Mast*

The following sections describe the installation procedure for each of the above.

7.2.1 Installing on a Brick or Masonry Wall

Table 7-1 describes the tools and equipment needed when installing on a brick or masonry wall.

Table 7-1 Required Tools And Equipment

Tools	Equipment	Quantity
Power drill	Mounting pole	1
¼ inch masonry drill bit	Anchor sleeves	4
A bubble level or plumb line	Lag bolts	4
Phillips head screwdriver or power drill		1
Hammer or mallet		1
Adjustable wrench		1

1. Place the mounting plate against the wall.
2. Using a level, be sure that the mounting pole is perpendicular to the ground.
3. Using a pencil, mark the hole locations for the drilled hole locations (Figure 6-2).

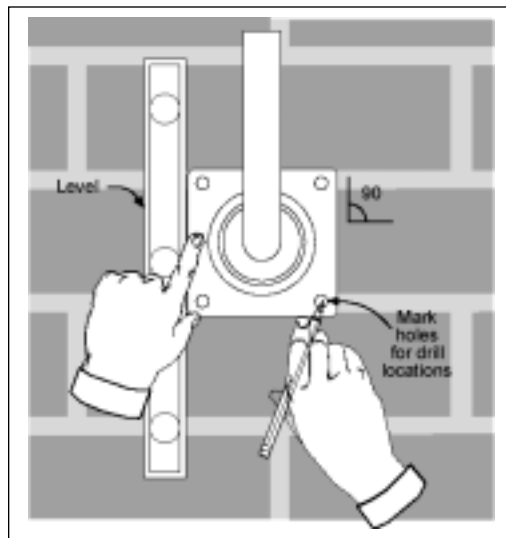

Figure 7-2 Mounting Pole Drill Locations

4. Set the mounting pole aside.
5. Using a ¼ inch masonry drill bit, drill holes approximately ½ inch deep at the marked locations.
6. Insert the anchor sleeves into the drilled holes. Using a small hammer, gently tap the anchor sleeves into the masonry until tight. Check that the anchor sleeves are flush with the wall. (Figure 6-3)
7. Align the mounting pole with the drilled holes.
8. Insert a lag bolt in each of the holes and hand tighten.
9. Tighten all lag bolts with a wrench, being careful not to over tighten.

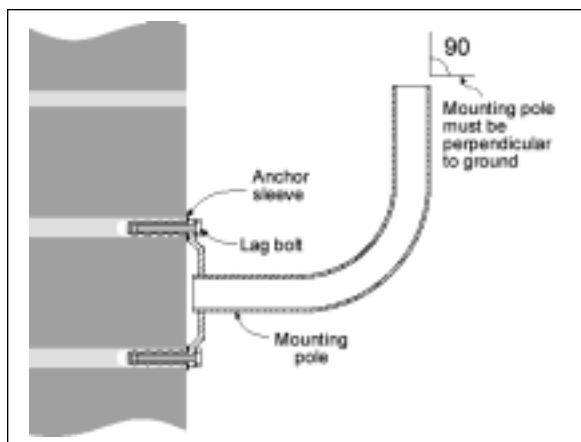

Figure 7-3 Mounting Pole Installation Using Expansion Sleeves and Lag Bolts

Attention! The mounting pole must be mounted in a vertical position. Failure to do so may result in improper alignment of the outdoor transceiver.

IMPORTANT – Before you install the SU, be sure to record, for future reference, the MAC address found on the SU.

10. Now proceed to *Installing the Outdoor Subscriber Unit* in Section 6.3.

7.2.2 Installing on a Wall with Wood Siding

Table 7-2 describes the tools and equipment needed when installing on a wall with wood siding.

Table 7-2 Required Tools and Equipment

Tools	Equipment	Quantity
Power Drill	Mounting pole	1
1/8 inch drill bit	#6 wood screws	4
Bubble level or plumb line	Spacers	1
Phillips head screwdriver or power drill		1

1. Place the mounting plate against the wall. Using a level, be sure that the mounting pole is perpendicular to the ground.

This procedure is similar to that shown previously in Figure 6-2.

Note that when mounting on clapboard siding, you may need to use spacers to make sure that the mounting pole is perpendicular, as shown in Figure 6-4.

Attention! The mounting pole must be in a vertical position for proper alignment of the outdoor transceiver.

2. Mark the locations for the drilled holes.
3. Remove the mounting pole and set it aside.
4. Drill 1/8 inch diameter in the places marked.
5. Use #10 or #12 wood screws to secure the mounting pole to the wall and hand tighten.
6. Using the level, check that the mounting plate is perpendicular to the ground. Readjust if necessary (you might need to add or remove spacers) and then tighten all screws with a screwdriver or power drill, being careful not to over tighten.

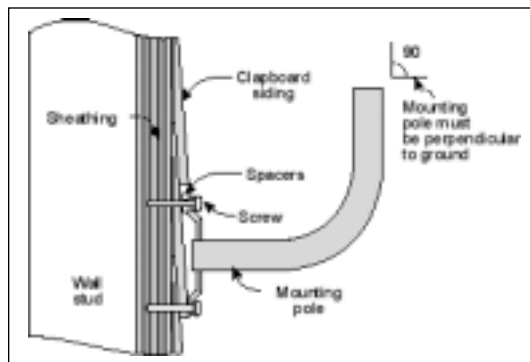

Figure 7-4 Mounting Pole on Clapboard Siding

7. Now proceed to *Installing the Outdoor Transceiver*.

7.2.3 Installing on an Antenna Mast

Table 7-3 describes the tools and equipment needed when installing on an antenna mast.

Table 7-3 Required Tools and Equipment

Tools	Equipment	Quantity
Adjustable wrench	U-bolts	2
	Washers	4
	Hex nuts	4

1. Position the mounting pole on the pole or antenna mast (Figure 6-5).
2. Insert the U-bolts around the pole and through the holes in the mounting pole.
3. Install a washer and nut to each side of the threaded U-bolts and hand tighten.

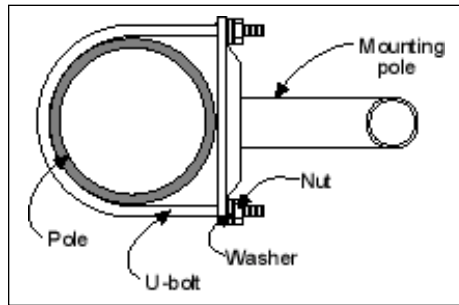

Figure 7-5 Mounting Pole Installed on Pole or Antenna Mast

4. Tighten nuts equally until mounting pole is secure and cannot rotate.

Attention! The mounting pole must be mounted in a vertical position. Failure to do so may result in improper alignment of the outdoor transceiver.

Warning! The mounting pole must be grounded. See *Grounding the System* in Section 6.6.

7.3 Installing the Outdoor Subscriber Unit

Now that you have installed the mounting pole, you are now ready to install the outdoor Subscriber Unit (SU) to the mounting pole. Table 7-4 describes the tools and equipment needed to install the SU.

Table 7-4 Required Tools and Equipment

Tools	Equipment	Quantity
Phillips-head screwdriver	Pole clamp	2
3/16" hex wrench	Washers	2
	Mounting screws	2

1. Loosen the mounting screws and place the outdoor Subscriber Unit on the mounting pole, as shown in Figure 6-6.
2. Hand tighten the mounting screws.
3. Rotate the outdoor transceiver in the direction of the Access Point.
4. Tighten the mounting screws.



Figure 7-6 Outdoor Subscriber Unit Mounted on Wall

7.4 Preparing The Indoor Junction Box

This section explains how to prepare the indoor junction box for installation. You will drill the mounting holes, but leave the box uninstalled, as it is easier to route the interconnect cable. Table 7-5 describes the tools and equipment you will need.

Table 7-5 Required Tools and Equipment

Tools Required	Equipment Required	Quantity
Phillips-head screwdriver	Screws	2
Flat head screwdriver	Wallboard inserts	2
Power drill		1
1/8 inch drill bit		1

1. Select a location for the junction box. This should be:
 - Somewhere you can easily connect to your PC and a power outlet.
 - Somewhere that is accessible for service and troubleshooting (not too close to the floor).
2. Remove the two screws which attach the junction box faceplate to the wall mount.
3. Set aside the faceplate with PCB and jack.

Attention! Be careful not to damage the two LEDs when removing the PCB.

4. On the Wall Mount portion of the Wall Box, use a flat head screwdriver, or a pair of thin-nosed pliers, to break out the pre-scored section of casing wall along the bottom edge of the junction box (see Figure 7-7). This is where later on you will route the interconnect cable.

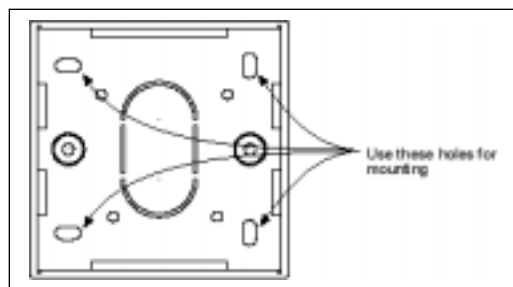

Figure 7-7 Junction Box Wall Mount (Face Plate and PCB Removed)

5. Using the wall plate as a template, mark the mounting hole locations, as shown in Figure 6-7.
6. Drill 1/8 inch diameter holes at the marked locations.
7. Insert the wallboard inserts.

For now, set the junction box to one side, leaving it disassembled. You will reassemble it and mount it on the wall when you have prepared and routed the interconnect cable and grounded the system.

7.5 Installing the Interconnect Cable

7.5.1 Routing the Interconnect Cable

Now that you have installed the outdoor Subscriber Unit and indoor junction box, you are ready to route the interconnect cable.

1. Select where the cable will enter the building from the outside (Figure 7-8).

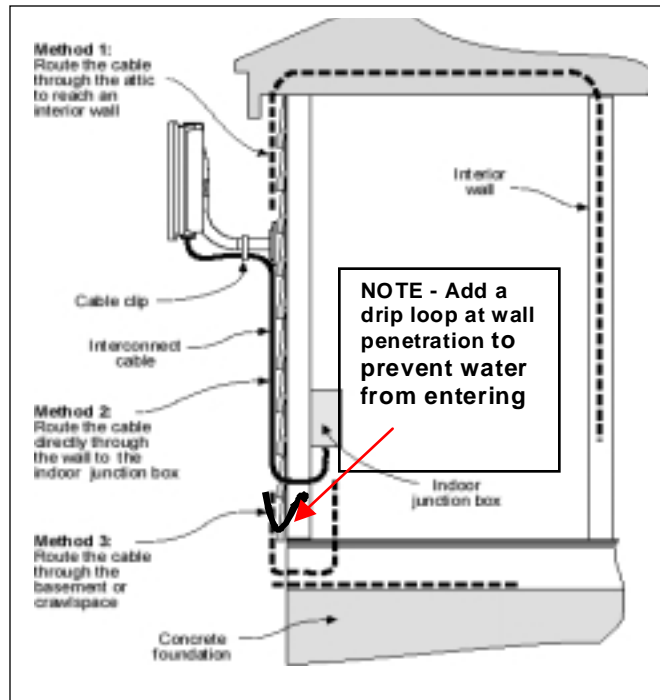

Figure 7-8 Interconnect Cable Routing Solutions

2. Once you have chosen the route, determine the length of cable required. Allow three extra feet on each end to allow for strain relief as well as any bends and turns.
3. Install the cable, leaving the ends free and ready to fit the RJ-45 connector (transceiver end), and install to the indoor junction box.
4. Remember to form a drip loop on the exterior of the building where the cable enters the penetration. This will help prevent water from entering.

7.5.2 Preparing the Interconnect Cable

Table 7-6 shows the tools you need to install an RJ-45 connector on the outdoor subscriber end of the interconnect cable.

Table 7-6 Required Tools and Equipment

Tools	Equipment	Quantity
Crimping tool (specific to RJ-45 used)	RJ-45 connector (metal bodied)	1
Wire stripper		
Small wire cutters		

1. Remove the grommet (Figure 7-9) and clamping plate from the Subscriber Unit by undoing the two screws. Be careful not to lose them if you are working on a ladder.

NOTE: The Grommet is made of a special conductive material used to complete the ground between the Subscriber Unit and indoor junction box.

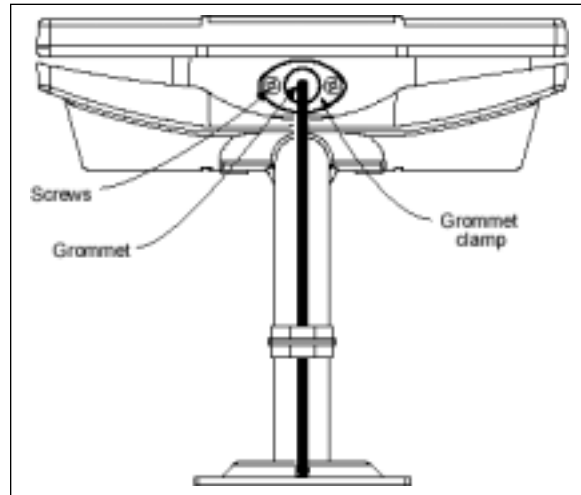

Figure 7-9 Grommet Location -- Underside of Subscriber Unit

2. Insert the cable end through the grommet clamping plate (Figure 7-10).
1. Insert the cable end through the grommet. The tapered end of the grommet should be opposite the cable end.
2. Strip 1 inch of insulation off the cable end. Leave 3/8 inch of shielding showing, and trim the wire ends flat 1/2 inch from there.
3. Using a piece of 1 inch squared tinned copper foil, wrap the foil around the shield/braid and sheath with the left edge aligned with the edge of the braid, as shown in the following Figures 7-10 and 7-11.

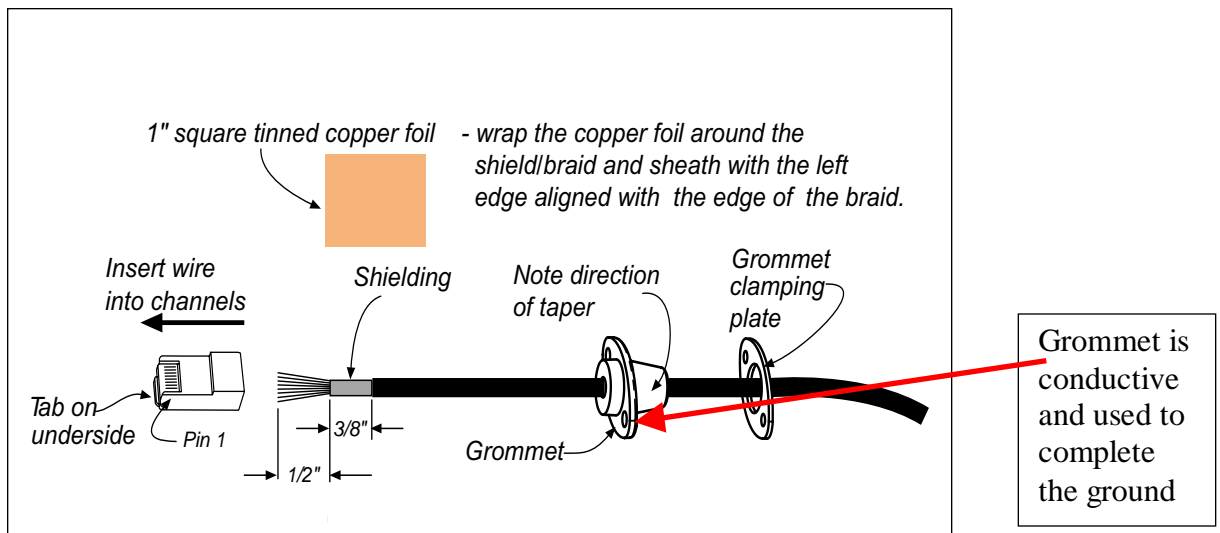

Figure 7-10 Outdoor Subscriber Unit of the Interconnect Cable with Cable Preparation

- Separate the twisted pair wires and align by color code in the order listed in the following Table 7-7.

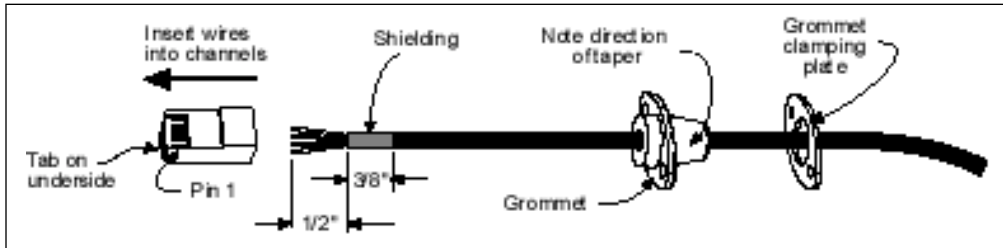

Figure 7-11 Outdoor Subscriber Unit End of the Interconnect Cable with Shielding

Table 7-7 Cable Legend for Interconnect Cable

Pin	Color Code
1	White / Orange
2	Orange
3	White / Green
4	Blue
5	White / Blue
6	Green
7	White / Brown
8	Brown

- Using pin 1 as a reference, insert the individual wires into the channels of the RJ-45 connector. Each wire should penetrate the channels until flush with the connector end. The copper foil tape should extend past the casing of the RJ-45 connector by approximately 1/2 inch.
- When all wires are inserted into the channels in their correct order, use the crimping tool to permanently crimp the wires to the connector.

Attention! Carefully read the instructions for the crimping tool you are using. Use the correct crimping tool for the RJ-45 connector you are using. Incorrect installation of the RJ-45 connector may result in a bad connection between the outdoor transceiver and the indoor junction box.

7.5.3 Connecting to the Outdoor Subscriber Unit Transceiver

Now that you have prepared the interconnect cable, you are ready to connect the cable to the outdoor Subscriber Unit.

Attention! Always Disconnect Power from wall box BEFORE inserting RJ-45 connector into transceiver. This prevents arcing damage from occurring.

1. Insert the RJ-45 connector into the receptacle located underneath the outdoor Subscriber Unit (refer to Figure 6-9). Make sure that the connector tab engages the slot in the receptacle.
2. Slide the grommet up the cable and press it into the bottom of the outdoor transceiver.
3. Slide the grommet clamp up the cable and align the holes with the mounting holes on the bottom of the outdoor transceiver.
4. Insert the two screws in the mounting holes and tighten until the grommet has a slight bulge. Be sure to tighten both screws equally so that the grommet is seated correctly.
5. Secure the interconnect cable to the mounting pole with the cable clip, as shown in Figure 7-12.

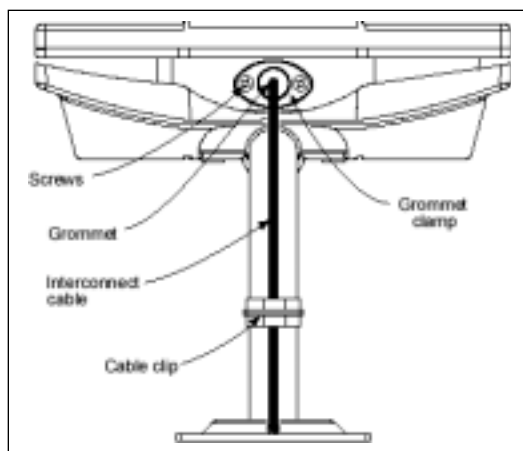

Figure 7-12 Interconnect Cable Installation to Subscriber Unit -- Bottom View

7.5.4 Connecting to the Indoor Junction Box

Note that the junction box should still be disassembled and not screwed to the wall at this point.

1. Strip 2 inches of insulation off the junction box end of the interconnect cable.

Attention! Don't cut off the shield from the cable – you will need it to ground the system later.

2. Insert the cable end through the notched out section of the junction box.
3. Reinstall the PCB into the junction box using the two screws, allowing enough of the interconnect cable to be able to reach the punch down block and wrap around the mounts of the cover plate for strain relief.
4. Using Figure 7-13 as a guide, use the 110 punch down tool to punch down each wire into the slot on the punch down block (reference the following Figure 6-16 which shows the inside of the Junction Box).

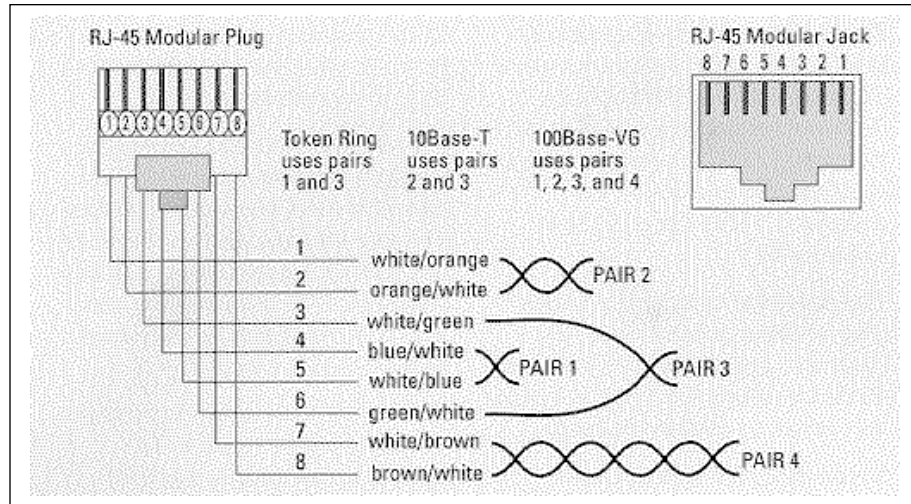

Figure 7-13 Interconnect Cable Connections to Indoor Junction Box

5. Snip off excess wire ends, if necessary.

Attention! Avoid excessive wire loops when connecting the wire to the punch down block.

For now, set the junction box to one side leaving it disassembled. You will reassemble it and mount it on the wall when you have grounded the system.

7.6 Grounding The System

The AB-Access System must be properly grounded in order to protect it and the building it is installed on from lightning damage. This requires grounding both the outdoor transceiver and indoor junction box. The following Table 7-8 describes the tools you will need to ground the system.

Table 7-8 Required Tools and Equipment

Tools	Equipment	Quantity
Mallet	Grounding rod	1
Wire stripper	#8 braided copper wire	
Wire cutters	Grounding lugs	2
Hex wrench	Grounding clamp	1

7.6.1 Installing A Grounding Rod

1. Place the grounding rod to allow for the shortest possible path from the grounding cable to the outdoor Subscriber Units.
2. Drive the grounding rod into the ground at least eight inches from the ground surface.
3. Attach a grounding clamp on the grounding rod. You will use this clamp to attach grounding wires for both the outdoor Subscriber Unit and indoor junction box.

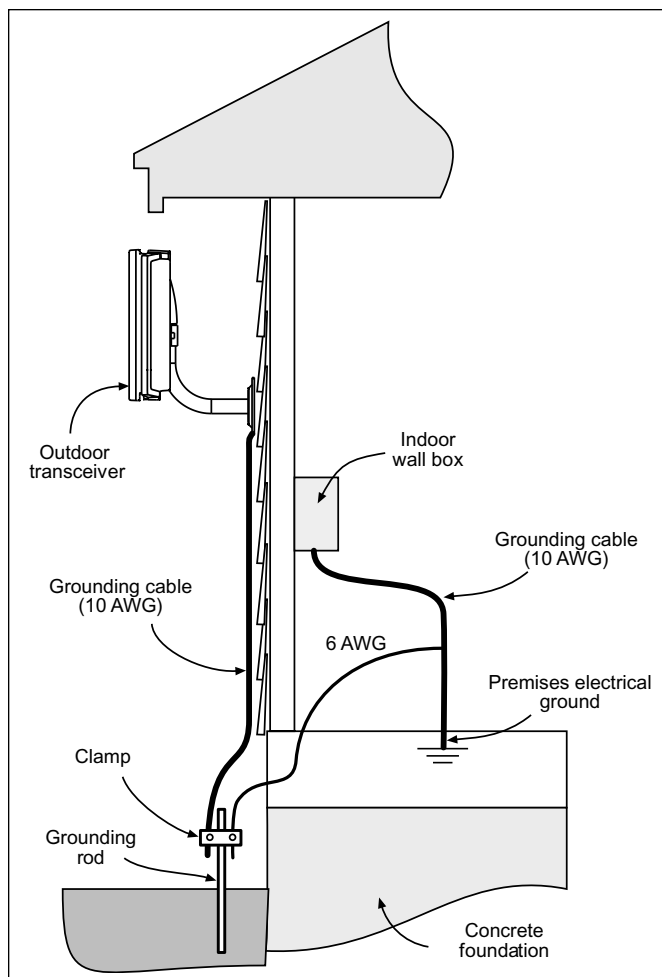

Figure 7-14 Ground Connections for Subscriber Unit

7.6.2 Grounding the Outdoor Subscriber Unit

1. To ground the outdoor Subscriber Unit, you will need to install a grounding wire from the mounting pole to the grounding rod. The wire should be long enough to reach from the mounting pole to the grounding rod with 3 to 6 feet extra to allow for strain relief.
2. Connect a ground lug to one end of a measured length of copper braided wire by crimping the lug to the wire, as shown in Figure 7-15.
3. Remove one of the lower mounting screws of the mounting pole. Insert a screw through the grounding lug terminal and re-install it to the mounting pole.
4. Attach the grounding wire to the clamp on the grounding rod. If necessary, use wire staples to secure the grounding wire to the outside wall.

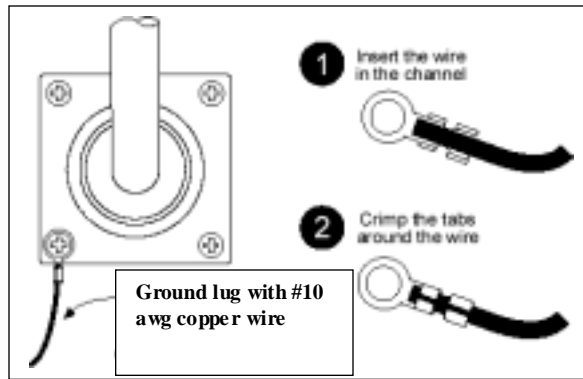
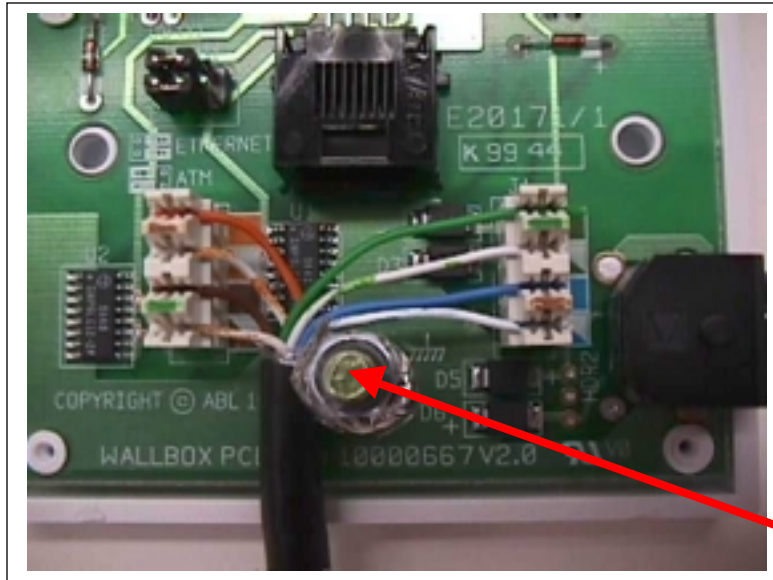

Figure 7-15 Mounting Pole with Ground Lug

7.6.3 Grounding the Indoor Junction Box

To ground the indoor junction box, you will need to install a grounding wire from the junction box to the grounding rod. The wire should be long enough to reach from the junction box to the grounding rod with 3 to 6 extra feet to allow for strain relief.

1. Feed the grounding cable through the broken out section of the wall cover (alongside the interconnect cable).
2. Connect a ground lug to the grounding cable by crimping the lug to the wire, as shown in Figure 7-15.
3. Remove the hex nut on the grounding post, as shown in Figure 7-16.
4. Install the grounding lug terminal onto the grounding post.
5. Attach the wire shield of the interconnect cable to the ground post. You may need to crimp or solder an extra length of wire to the shield in order to attach it to the grounding post.
6. Re-install the hex nut to the grounding post and tighten.
7. Attach the grounding wire to the clamp on the grounding rod.
8. Use the provided small wire tie to firmly attach the interconnect cable to the ground lug. This will provide strain relief for the cable and prevent the data and power leads from being disturbed during installation.



**Indoor
Junction Box
Ground
Connection**

Figure 7-16 Indoor Junction Box Ground Connection

7.6.4 Assembling and Mounting the Junction Box

1. Place the junction box wall mount over the drilled holes.
2. Insert the screws and tighten.
3. Reinstall the faceplate onto the junction box using the two screws.

SECTION 8

Indoor Junction Box**8 Indoor Junction Box**

The indoor junction box/wall box consists of a PCB that inserts power into the CAT-5 cable and provides secondary lightning protection. Photos of the indoor Junction Box are shown in Figures 8-1 and 8-2.

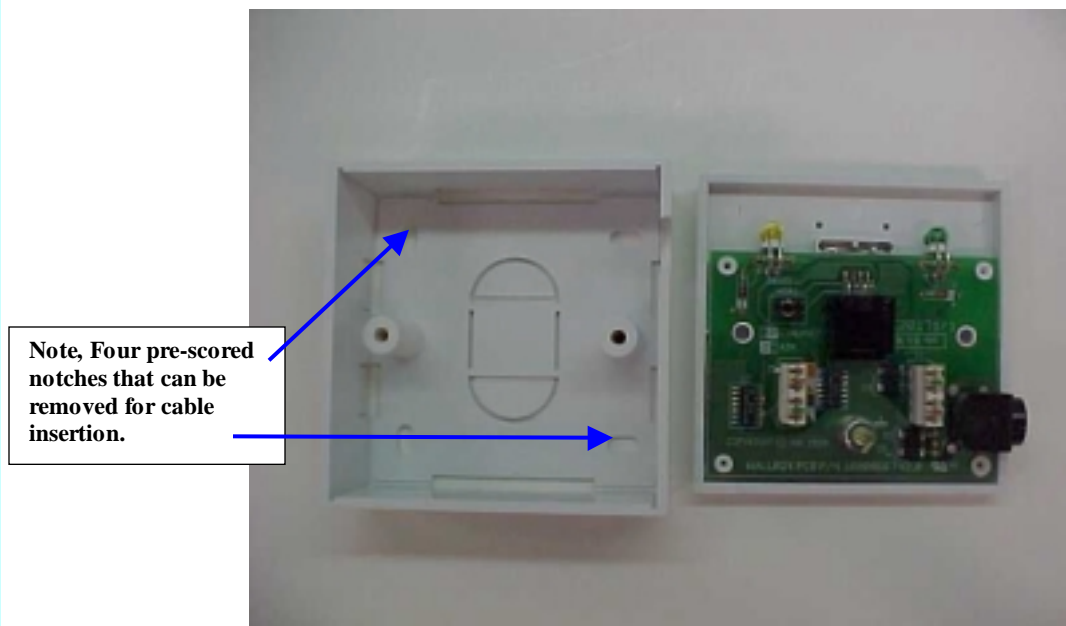

Figure 8-1 Indoor Junction Box (Wall Plate Enclosure)

The indoor junction box can be wired for ATM25 or Ethernet interfaces. Note that the PCBs may be housed in separate plastic boxes or mounted in a card cage. Table 8-1 describes the cable legend to follow.



Figure 8-2 Indoor Junction Box Inside

Table 8-1 Cable Legend - Junction Box Interconnect Cable

Pin	Signal	Color Code
1	Transmit High (+)	White / Orange
2	Transmit Low (-)	Orange
3	LED2	White / Green
4	Supply Minus	Blue
5	Supply Plus	White / Blue
6	LED1	Green
7	Receive High (+)	White / Brown
8	Receive Low (-)	Brown

8.1 ATM Cross-Over Cable

Figure 8-3 shows how to wire an ATM cross-over cable:

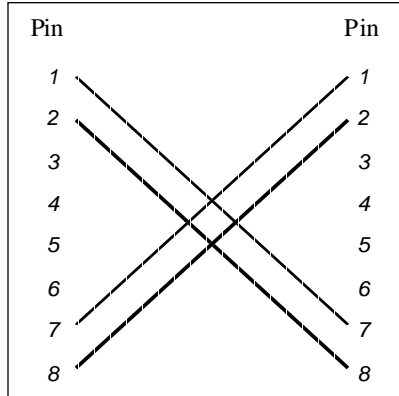

Figure 8-3 ATM Cross-Over Cable

8.2 FVC DB-9 To RJ-45 Converter

Figure 8-4 shows a DB-9 to RJ-45 converter.

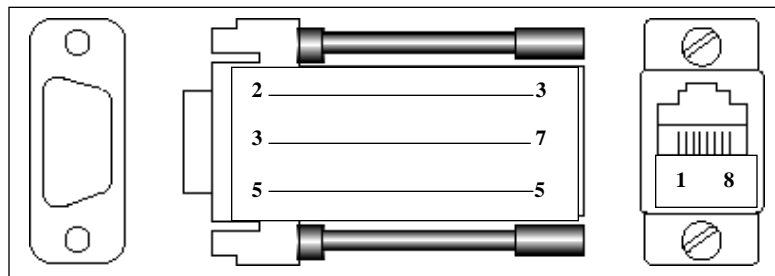

Figure 8-4 DB-9 To RJ-45 Converter

SECTION 9

Testing the System

9 Testing the System

9.1 Introduction

This section explains how to:

- Power up your AB-Access System
- Use a PC (known as the *Test PC*) to check the alignment of your outdoor transceiver
- Make sure you have the best connection to your service provider.

Attention! This operation may need two people – one to operate the Test PC and one to align the outdoor transceiver.

Note: For purposes of AB-Access Extender, the two ends of the AB-Access Extender link appear like **static** point-to-point AP and SUs with respect to testing.

9.2 Equipment Required

You will need the following equipment to test your AB-Access System:

- Standalone PC or laptop (Test PC) with a web browser (e.g., Netscape Navigator 4.5 or higher, Internet Explorer 4.0 or higher).
- Standard 10Base-T Ethernet cable with RJ-45 connectors to connect the Test PC to the indoor junction box.

You will also need to know the correct IP address and subnet mask to configure the Test PC. Your service provider should have supplied these. The defaults for an SU are 192.168.3.254 Netmask 255.255.255.0.

9.3 Testing

In order to be able to check the alignment of your outdoor transceiver, along with the connection to your service provider, you need to know how to configure an IP address and subnet mask. If you are not sure how to do this, look in the manual that came with the PC you are using as the Test PC. You could also check the online help.

9.3.1 Connecting Test PC

1. Connect the Test PC to the indoor junction box using a standard 10Base-T Ethernet cable (with RJ-45 connectors).
2. Insert the power plug adapter into the indoor junction box.
3. Insert the AC power plug into an AC outlet.
4. Check the LEDs on the junction box.

Attention! If the yellow LED is on, this indicates that power is being supplied to the unit. If not, check the connections.

9.4 Configure The IP Address

1. Switch on the Test PC.
2. Configure the Test PC to use the recommended IP address supplied by your system provider or installer (example: 192.168.3.1).
3. Configure the Test PC to use the recommended netmask supplied by your system provider or installer.

Attention! These steps make sure that the test PC is on the same subnet as the AB-Access System. The last number in the Test PC's IP address must be different from the last number in the IP address of the AB-Access System (see below).

9.5 Using the RSSI Interface for RF Alignment

One of more challenging aspects to RF systems is proper alignment of antennas. With distances up to 3 miles, it can be very difficult to align an SU with an AP. To solve this problem, the RF signal strength and packet error rate can be measured to provide feedback, which can be used to properly align a unit. This information is typically called the *Receive Signal Strength Indicator (RSSI)*.

While the RSSI interface is always present, it is primarily designed for use with SUs being initially deployed. To use the RSSI interface, the SU should be set to “installation” mode when upgraded in the Operation Center. Installation mode is used for SUs to be used in a dynamic registration (EMS) environment. When an SU is in installation mode, the SU will wait for the installer to align the antenna and will register only after the installer has initiated the registration sequence via the browser interface. This is slightly different from registration mode, where the SU automatically registers with the strongest AP immediately after booting.

For realignment, the SU must be set back into Installation mode from the hmm sub process by issuing the command:

```
hmm> system mode installation
```

While the RSSI interface is always present, when not set to Installation mode, the SU will not attempt registration once the proper channel is selected.

The RSSI application can also be effective in Static or Registration mode in analyzing the RF landscape with respect to other AB-Access components. Using the RSSI interface, the network manager can get readings on RSSI and Packet Error Rates in a convenient display. The only difference is the SU to register in these modes. Registration via the RSSI interface only occurs when the unit is in Installation mode.

To take advantage of this information, the AB-Access Subscriber Units contain an interface, which allows the installer to properly align the unit. Once an SU is mounted in place and roughly aligned using a compass, the installer can attach a computer to the terrestrial interface of the SU and interact with the RSSI web page on the SU to perform alignment (reference Figures 9-1 and 9-2). Connecting to the SU and enabling the RSSI interface is performed in the manner described in the following sections.

NOTE: The RSSI interface is best viewed using a screen resolution of at least 800x600 with 256 colors. Netscape Navigator is recommended as the viewing browser, reference following Figure 9-1 RSSI Sample Web Page.

9.6 Display The Security Page

1. From your Test PC, start up a web browser.
2. In the URL field, enter the default IP address of the AB-Access System (supplied by your service provider (example, <http://192.168.3.2>).
3. The Security screen appears as shown in Figure 9-1.

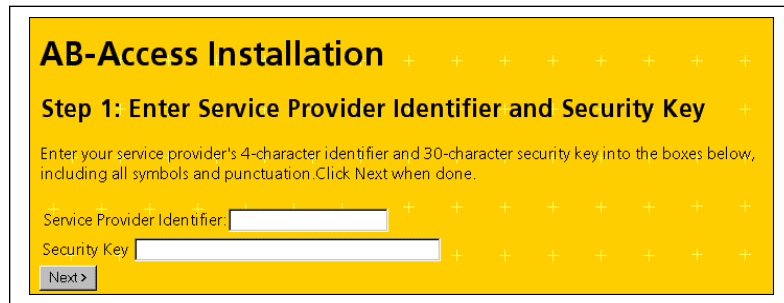

AB-Access Installation

Step 1: Enter Service Provider Identifier and Security Key

Enter your service provider's 4-character identifier and 30-character security key into the boxes below, including all symbols and punctuation. Click Next when done.

Service Provider Identifier:

Security Key

Figure 9-1 Security Screen

9.7 Optimize The Antenna Alignment

At the security screen, enter the Service Provider Identifier and Security Key. The key is supplied by your service provider as a secure login.

Click **Next**. The Antenna Alignment screen appears as shown in Figure 9-2.

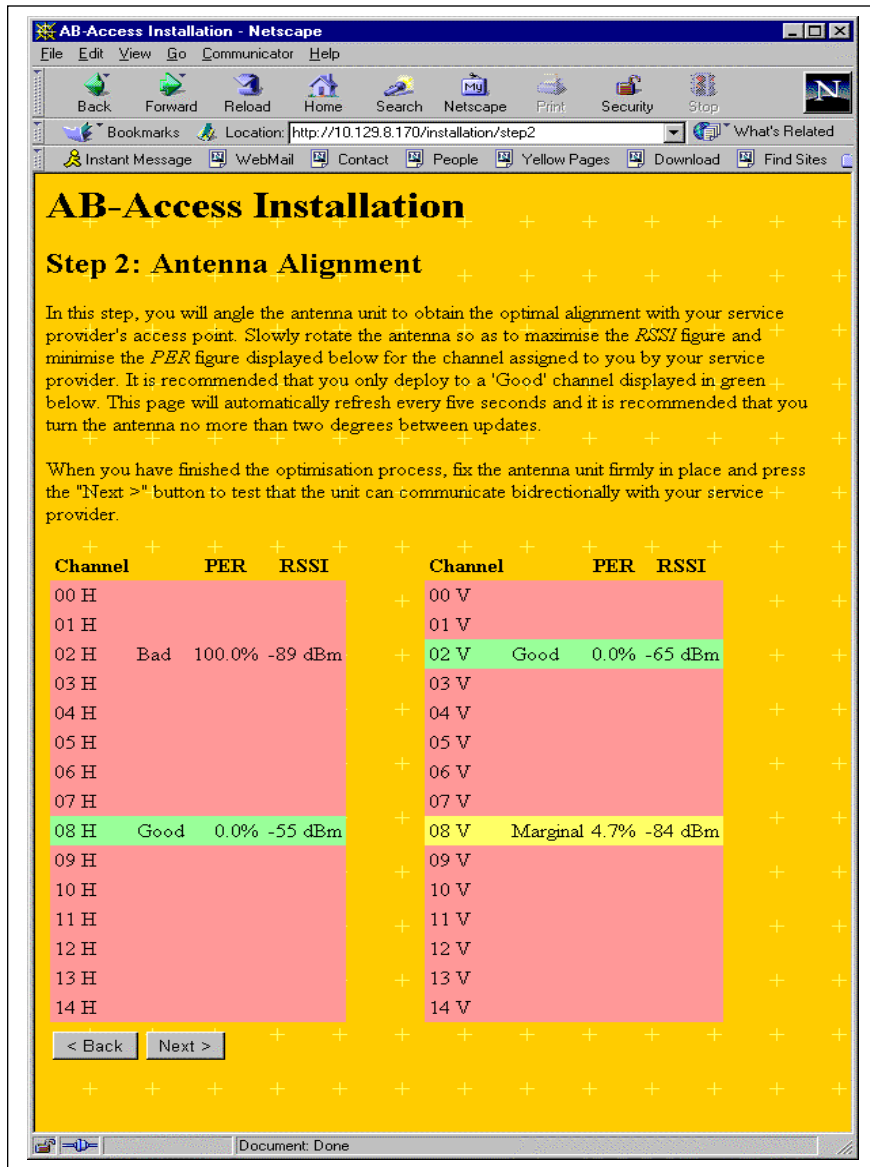

Figure 9-2 RSSI Sample Web Page

1. Note the desired channel for registration (example, Channel 14, horizontal polarization).
2. Attach a computer to the terrestrial interface of the SU.
3. Change computer IP address to be in the same subnet as the SU. For example, set the computer to address 192.168.254.1 to connect to an SU with the IP address of 192.168.254.254.
4. Verify connectivity to the SU using the Ping utility (example, ping 192.168.254.254)
5. Open a browser interface on the computer (Netscape Navigator is recommended)
6. Enter the address of the RSSI web interface:

<http://<ip address of SU>/installation/step2> (ex <http://192.168.254.254/installation/step2>)

7. This will display two columns of data, one column for RF channels using horizontal polarization and a second for vertical polarization. Turn the SU in 2 degree arcs until the channel desired is listed as “Good” and is green in color.
8. Click on the “next” button to initiate registration of the SU with the AB-Access network.

The RSSI web interface will refresh itself every 5 seconds, allowing the installer to adjust the SU until the best alignment possible is achieved. The RSSI application will actually rank connection validity. Table 8-1 details these rankings.

Table 9-1 RSSI Link Validity

Link Validity	Color	CNR ²	PER ¹
Good	Green	Greater than or equal to 10dB	Less than 1%
Marginal	Yellow	Less than 10dB	Less than 1%
Bad	Pink	Non Applicable	Greater than 5%

¹: PER is Frame Downlink Header Error Rate (FDHDR)

²: CNR = RSSI -81.6dbm

Bad links will not allow any registration. Marginal links will allow registration but may be subject to interference by a number of factors. Good links will be the best selection for registration.

SECTION 10

Specifications

10 Specifications

10.1 Subscriber Unit Antenna

Table 10-1 describes the Subscriber Unit (SU) Antenna specifications and Figure 10-1 shows a typical SU antenna pattern.

Table 10-1 Subscriber Unit Antenna Specifications

Peak Gain	18 dBi
3 dB beam width	20° azimuth x 20° elevation
Front to back ratio	30 dB
Sidelobe suppression	15 dB
Input impedance	50 Ohms
Polarization	Linear – vertical or horizontal switchable
VSWR	2:1 max

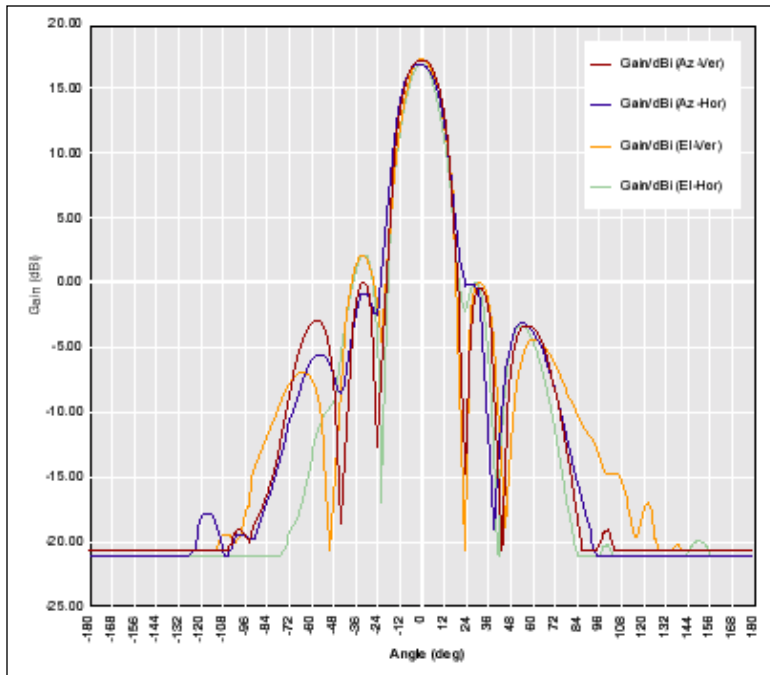

Figure 10-1 Typical SU Antenna Pattern

10.2 Access Point Antenna

Table 10-2 describes the Access Point antenna specifications and Figure 10-2 shows a typical AP antenna pattern.

Table 10-2 Access Point Antenna Specifications

Peak gain	18 dBi	typical
3 dB beamwidth	60° azimuth x 7° elevation	typical
Front to back ratio	25 dB	min
Sidelobe suppression	15 dB	min
Input impedance	50 ohm	typical
Polarization	Linear vertical or horizontal switchable	
VSWR	2:1 max	

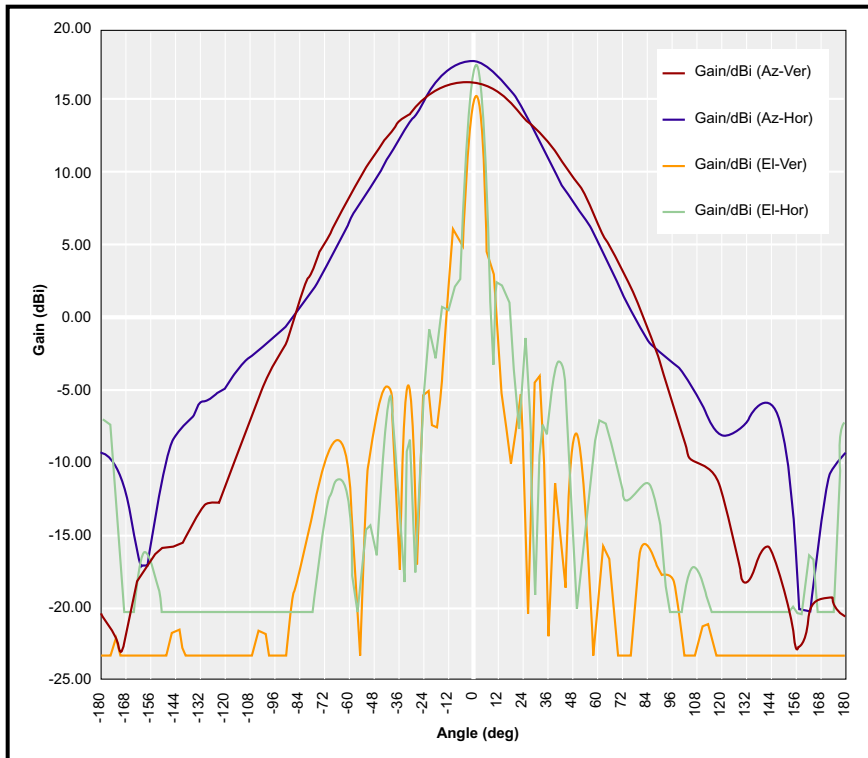

Figure 10-2 Typical AP Antenna Pattern

10.3 AB-Access Extender Antenna

Table 10-3 describes the AB-Access Extender antenna specifications and Figure 10-3 shows a typical EX antenna pattern.

Table 10-3 AB-Access Extender Antenna Specifications

Peak gain	23 dBi	typical
3 dB beamwidth	10° azimuth x 10° elevation	typical
Front to back ratio	25 dB	Min
Sidelobe suppression	15 dB	Min
Input impedance	50 ohm	Typical
Polarization	Linear vertical or horizontal switchable	
VSWR	2:1 max	

TBD: Insert AB-Access Extender Antenna Pattern image

Figure 10-3 Typical EX Antenna Pattern

TBD: Update all section and figure numbers from here on forward

10.4 Modem Specifications

The QPSK modem design for the transceiver is driven primarily by the 32-symbol correlator and Decision Feedback Equalizer (DFE). The correlator output is used for:

- Burst detection
- Digital AGC setting
- Phase reference
- AFC control
- Course symbol timing.

The DFE is used to remove the Inter-Symbol Interference (ISI) introduced by the filters and imperfect sampling, as well as compensate for pre-cursor and post-cursor channel multipath. Table 10.4 shows the Modem Specifications.

Table 10-4 Modem Specifications

Modulation	Coherent QPSK
Symbol rate	12.5 Msym/s
ADC	10 bits I and Q
Receive filter	Root raised cosine $\beta=0.35$
AWGN performance	14.4 dB CNR for 10^{-4} BER (including 3 dB implementation loss)
Equalizer	Decision Feedback (DFE); 5 forward taps, 4 feedback taps; delay spreads up to 0.32 μ s; post cursor to cursor ratios up to 0.5
Training	32 symbols per burst
Transmit filter	Raised cosine $\beta=0.35$

10.5 Environmental Specifications

10.5.1 Temperature/Humidity Operation

The entire unit is constructed in a weatherproof housing and designed for outdoor use. The minimum and maximum operating temperatures and the relative humidity for all system elements are listed in Table 10.5.

Table 10-5 Environmental Specifications

Item	Operating Temperature Range, min	Operating Temperature Range, max	Operating Humidity, max
Subscribe Unit, Access Point and AB-Access Extender	-40°C (-40°F)	55°C (131°F)	100

10.5.2 Grounding

Article 810 of the U.S. National Electric Department of Energy Handbook 1996 specifies that radio and television lead-in cables must have adequate surge protection at or near the point of entry to the building. The code specifies that any shielded cable from an external antenna must have the shield directly connected to a 10 AWG wire that connects to a building ground electrode.

10.5.3 Electrical Specifications

The Subscriber Unit is powered from a typical notebook-style power supply that is included with the unit. This power supply is plugged into a standard 110/220 VAC main (or a UPS unit) and the output supply of 48 VDC is plugged into a wall box which feeds the -48 VDC through the CAT5 cable to the installed units, reference Figure 9-3. The power supplies used to convert 110 VAC to 48 VDC are 80% efficient at this load.

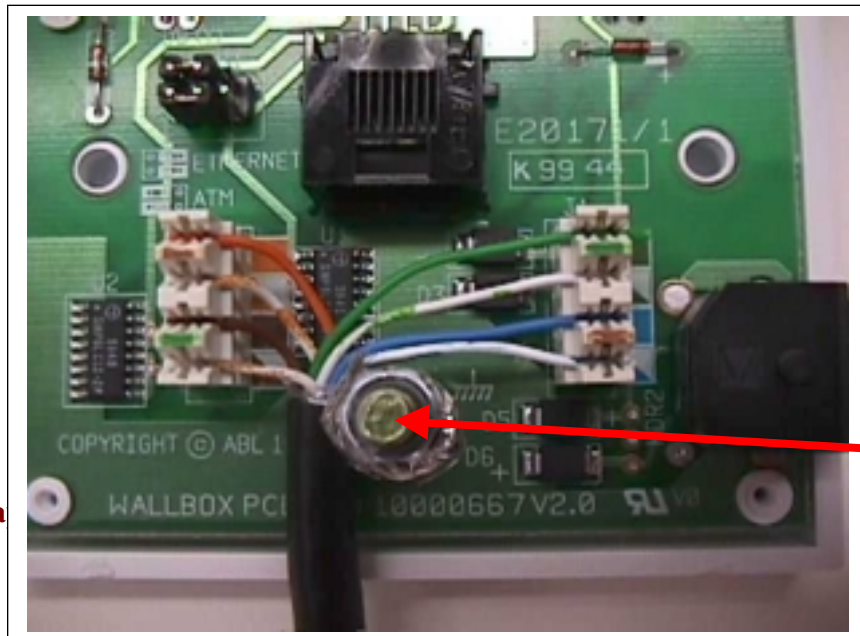

Wire shield to grounding post and to grounding rod

Figure 10-4 Powering SU through Junction Box

10.5.4 Power Consumption

Table 10-6 shows the power consumption of an SU, EX and AP.

Table 10-6 SU, EX and AP Power Consumption

Item	Power Source	Power Range	Power Consumption W (typical)
Subscriber Unit, AB-Access Extender and Access Point Unit	48 VDC	38 to 72 VDC including fluctuations	14

10.5.5 Distance Limitations

The SU uses shielded outdoor rated CAT5 cable between the installed unit and the indoor junction box. For the unit to receive acceptable voltage to operate, this cable is limited to 60 meters. Between the junction box and the customer premises PC (or hub, Ethernet Switch, Router, etc.), the system uses standard indoor CAT5 cable, which is rated for a maximum functional distance of 100 meters when running the Ethernet 10BaseT interface. For an AP (or SU) connected via ATM25, the distance limitation of the data signaling is 270 meters.

10.5.6 Physical Specifications

Table 10-7 provides the weight and dimensions of an SU.

Table 10-7 SU Weight and Size

Item	Weight	Dimension
Subscriber unit	7.8 lb. (3.5 kg)	13W x 13H x 3D in. (32W x 32H x 8D cm)

10.6 Cable Specifications

10.6.1 Outdoor Cable Specifications

The following Table 10-8 describes all the outdoor cable specifications.

Table 10-8 Outdoor Cable Specifications

Item	Specification
Product type	Twisted pair
Performance category	CAT 5
Frequency	100 MHz
No. of pairs	4
Impedance	100 Ohms +/- 15 Ohms
Capacitance (nominal)	4.5 nF/100 meters
Attenuation	EIA/TIA 568 CAT5
Near end cross talk	EIA/TIA 568 CAT5
DC resistance/unbalanced	< 10 Ohms/100 meters max.
Shielded	Yes
Wire/cable type	Solid
Wire size	24 AWG
Cable outer diameter (nominal)	0.232 inches
Jacket thickness (nominal)	0.030 inches
Cable jacket material	Polyethylene, UV resistant
Conductor material	Copper
Insulation material	Solid polyolefin
Shield type	BBDN or BBDG
Dielectric breakdown	2500 Volts DC conductor to conductor
Operating temperature range	-40° C to +70° C
Installation temperature range	0° C to +60° C

10.7 RJ-45 Plug Specifications

Table 10-9 describes all the RJ-45 plug specifications.

Table 10-9 RJ-45 Plug Specifications

Item	Specification
Product type	Plug
No. of positions	8
Shielded	No
Cable style	Round solid
Performance category	High (Cat 5)
Latch style	Standard
Keyed	No
Housing material	Polycarbonate
Housing material flammability rating	UL 94V-2
Contact material	Phosphor bronze
Contact mating area plating	Gold (50) over nickel
Contact termination end plating	Gold Flash over nickel
Conductor outer diameter (mm [in])	.89-.99 [.035-.039]

11 Glossary & Acronyms

TERM	DEFINED
Access Point	An Access Point (AP) is a component of a Base Station (BS) that contains the antenna used to communicate with a Subscriber Unit (SU).
Anchor Switch	The Anchor Switch (AS) is an ATM access switch that is a component of a Base Station (BS).
Antenna	A device for transmitting and/or receiving radio waves.
Asynchronous	A data transmission method in which data may be sent at irregular intervals (without reference to clock signals).
ATM	Asynchronous Transfer Mode is a high-performance, cell-oriented switching and multiplexing technology, which utilizes fixed-length packets to carry different types of traffic. It integrates the multiplexing and switching functions, is well suited for bursty traffic, and allows communications between devices that operate at different speeds.
ATM Switch	The ATM switch provides layer 2 switching of ATM cells through virtual circuits. An ATM switch is contained in the SU, the AP, and the AS.
Available Bit Rate (ABR)	Service that provides rate-based flow control and is aimed at data traffic such as file transfer and e-mail.
Azimuth	The angle along the horizon usually referenced to north.
Bandwidth	The data carrying capacity of a communications channel, measured in Hertz as the difference between the highest and lowest frequencies of the channel.

Base Station	The Base Station is the part of the AB-Access System that sends signals to and receives signals from the Subscriber Units (SUs) to enable communication with the WAN.
Baud	A measure of data transmission speed. The baud rate denotes the number of symbols per second.
Bit Error Rate	The Bit Error Rate (BER) is the fraction of transmitted bits that are received in error.
Cell	A 53-Byte packet of data used in ATM networks. Also used to refer to the coverage area of one Base Station.
Constant Bit Rate (CBR)	Service that operates on a connection basis and offers consistent delay predictability; used for applications such as circuit emulation, voice, and video.
Control Server	The Control Server (typically one per BS) is a computer responsible for management of the BS, its APs, and the associated SUs.
DS1	A data transmission rate of 1.544 Mbps, also referred to as a T-1.
DS3	A data transmission rate of 45 Mbps
Element Management System	The Element Management System (EMS), located on a workstation at an appropriate point in the network, allows you to configure, control, and monitor all components of the AB-Access System.
MIB	Management information base allows external management system access.
Multiplexer	A multiplexer is device or system capable of combining elementary streams into one aggregate transport stream.
Network	A network is an interconnection of computer systems, terminals, or data communications facilities.
OC3	A data transmission rate of 155 Mbps
Packet	A packet is a sequence of data, with associated control information, that is switched and transmitted as a whole.
Packet Switching	Packet switching is the data transmission method that divides messages into standard-sized packets for greater efficiency of routing and transport through a network.
Parsing	Parsing is the process of analyzing a data stream and breaking it down into more easily processed components.

Permanent Circuit	Virtual	Provides end-to-end connectivity for transmission in a network.
Point-to-Point		A single communication circuit connecting two locations.
Point-to-Multipoint		A communications circuit connecting one location to many locations.
Radio Frequency		Radio frequency (RF) is a portion of the electromagnetic spectrum in the frequency range of 100 kHz to 20 GHz.
Subscriber Unit		The Subscriber Unit (SU) is the part of the AB-Access System that is installed at the customer premises and provides communication with the Base Station (BS).
Synchronous		A data transmission method in which data transfer is at a fixed rate. The transmitter and receiver are both controlled by clock pulses.
TCP/IP		Transmission Control Protocol/Internet Protocol, a layered set of protocols that allows sharing of applications among PCs, hosts, or workstations in a high-speed communications environment. The suite of protocols is designed to allow communication between networks regardless of the technologies implemented in each network.
TDD		Time Division Duplex, the transmission method where a single channel is used to alternately carry data in each direction of a link.
Time-Division Multiplexing		A form of multiplexing used with digital signals. A device scans individual channels in rotation, takes bits from each channel, transmits the bits in a string (according to a predetermined sequence), and repeats the process.
Transmitter		A transmitter is an electronic device, consisting of oscillator, modulator, and other circuits, that produce a radio or television electromagnetic wave signal for radiation into the atmosphere by an antenna.
Unspecified Bit Rate		Service that operates on a connection basis and allows for raw cell or best effort transport by the network. In this service, cells are transported by the network whenever bandwidth is available and traffic is presented by the user. Data using UBR service is more apt to be discarded during peak traffic times in

	deference to data using other classes of service.
Uninterruptible Power Supply	An optional BS element used to provide power in the event of an AC power failure.
Variable Bit Rate-Real Time (VBR-RT)	Service that operates on a connection basis and offers very low delay variance but requires access to a variable amount of network bandwidth; used for such applications as packet video and voice.
Variable Bit Rate-Non-Real Time (VBR-NRT)	Service that operates on both a connection and connectionless basis and allows delay variance between the delivery of cells; used for data applications which have potentially bursty traffic characteristics, including LAN interconnect, CAD/CAM, and multimedia.
Virtual Circuit	A logical connection, not a physical connection, provides multiple connections that can be defined simultaneously across a single network facility, with each connection having flexible bandwidth.

11.1 Acronyms/Abbreviations

The following is a list of acronyms and abbreviations associated with the AB-Access System, some of which may appear in this guide.

ACRONYM	DEFINED
AAL	ATM Adaptation Layer
ADC	Analog to Digital Converter
AFC	Automatic Frequency Control
AGC	Automatic Gain Control
ALG	Application Layer Gateway
AP	Access Point
ARP	Address Resolution Protocol
ARPAnet	Advanced Research Projects Agency Network
ARQ	Automatic Repeat Request
AS	Anchor Switch
ASIC	Applications Specific Integrated Circuit
ATM	Asynchronous Transfer Mode
ATMOS	ATM Operating System
AWGN	Additive White Gaussian Noise
BER	Bit Error Rate
BOOTP	Bootstrap Protocol
BS	Base Station
CBR	Constant Bit Rate
CCIR	Comite Consultatif International des Radiocommunications
CHAP	Challenge-Handshake Authentication Protocol
CIDR	Classless Interdomain Routing
CLIP	Classical Internet Protocol
CNR	Carrier To Noise Ratio
COTS	Commercial Off The Shelf

CPE	Customer Premise Equipment
CS	Control Server
dB	Decibel
dBm	Decibel over 1mW
DBS	Direct Broadcast Satellite
DC	Direct Current
DES	Data Encryption Standard
DFE	Decision Feedback Equalizer
DHCP	Dynamic Host Configuration Protocol
DS1,2,3	Digital Signal 1,2,3
E1	2.048 Mbps circuit supporting (30) 64 Kbps digital channels for voice or data calls
EIRP	Effective Isotropic Radiated Power
EMS	Element Management System
FCC	Federal Communications Commission
FDD	Frequency Division Duplex
FPMS	Fault and Performance Management System
Gbps	Gigabits per second
GFC	Generic Flow Control
GHz	Gigahertz
GUI	Graphical User Interface
I&Q	In Phase and Quadrature
IETF	Internet Engineering Task Force
IF	Intermediate Frequency
IP	Internet Protocol
ISI	Inter-Symbol Interference
ITFS	Instructional Television Fixed Service
Kbps	kilobits per second
LAN	Local Area Network
LLC	Logical Link Control

LOS	Line of Sight
MAC	Media Access Control
Mbps	Megabits per second
MDS	Multipoint Distribution Service
MIB	Management Information Base
MID	Mobile ID
MMDS	Multichannel Multipoint Distribution System
MSE	Mean Square Error
NAT	Network Address Translation
NMS	Network Management System
NOC	Network Operations Center
OAM	Operations, Administration, and Maintenance
OC3	Optical Carrier 3
OSI	Open Systems Interconnection
PAT	Port Address Translation
PCB	Printed Circuit Board
PHY	Physical Layer
POTS	Plain Old Telephone System
PPP	Point-to-Point Protocol
PTMP	Point to Multipoint
PVC	Permanent Virtual Circuit
QOS	Quality of Service
QPSK	Quadrature Phase Shift Keying
RAID	Redundant Array of Inexpensive Disks
RF	Radio Frequency
RFC	Request For Comment
RISC	Reduced Instruction Set Computer
RSSI	Receiver Signal Strength Indication
RT-VBR	Real Time Variable Bit Rate

RX	Receiver
SAR	Segmentation And Reassembly
SCSI	Small Computer System Interface
SNMP	Simple Network Management Protocol
SNR	Signal to Noise Ratio
SO/HO	Small Office/Home Office
SONET	Synchronous Optical Network
STP	Shielded Twisted Pair
SU	Subscriber Unit
SUMP	Subscriber Unit Management Protocol
SVC	Switched Virtual Circuit
T1	1.544 Mbps circuit supporting (24) 56/64 Kbps voice-grade channels
TCP/IP	Transmission Control Protocol/Internet Protocol
TDD	Time Division Duplex
TDMA	Time Division Multiple Access
Telnet	Terminal-remote host protocol developed for ARPAnet
TMS	Topology Management System
TX	Transmit
UBR	Unspecified Bit Rate
UDP	User Datagram Protocol
UNI	User-Network Interface
U-NII	Unlicensed National Information Infrastructure
UPS	Uninterruptible Power Supply
UTP	Unshielded Twisted Pair
VBR-RT	Variable Bit Rate-Real Time
VBR-NRT	Variable Bit Rate-Non-Real Time
VCC	Virtual Circuit Connection
VPC	Virtual Path Connection
VPI	Virtual Path Identifier

WAN	Wide Area Network
WLL	Wireless Local Loop

