

# AW-CB178NF

## Wireless LAN & Bluetooth Module IC

### MFG Tool Command User Guide

Version 0.1

Document release	Date	Modification	Initials	Approved
Ver. 0.1	2014/09/22	Initial version	Terry Chu	

Inspired by wireless

Confidential

- Warning!! This is a message from Azurewave and the information you are viewing now is strictly confidential and is a knowledge property to Azurewave.
- Unauthorized use of this document is prohibited and Azurewave retains the right for legal actions against any loss suffered or expenditure due to the misuse of any information from this document.

# 1. AW-CB178NF WLAN & Bluetooth MFG Tool Command User Guide

## 1.EVB Block Diagram

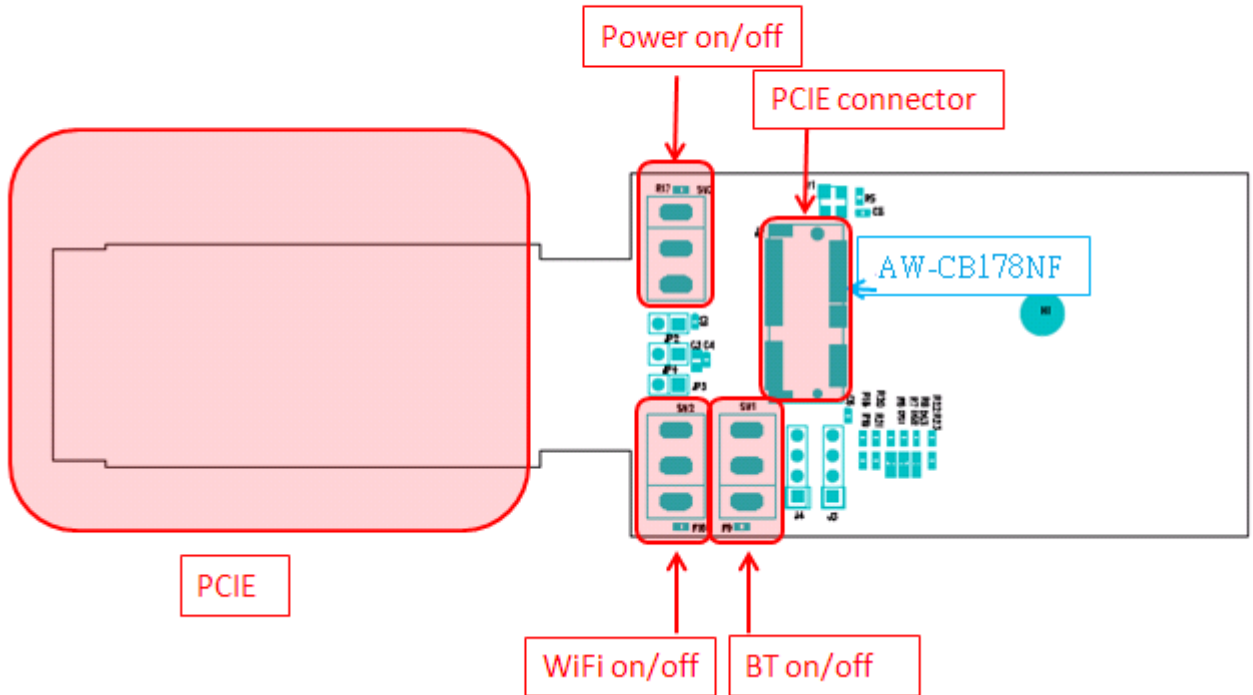

- When you test AW-CB178NF, please insert AW-CB178NF into connector J2 in the first. And you need to take a screw column with H1 hole to make AW-CB178NF combined with carrier board.

### 1.1 Environment set up and Bridge Mode Tool

(1) The “Manufacturing Bridge” refers to the application that allows a user to send commands between Target platform and Windows XP platform. The environment enables the user to test performance of the AW-CB178NF.

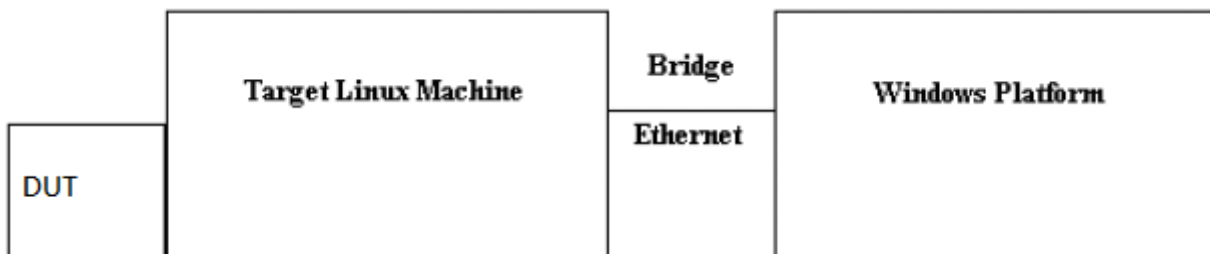

Manufacturing Bridge mode

## (2) bin Folder Contents

Download the latest MFG release from the Marvell Extranet and unzip it. The bin folder should look similar to the figure shown below. The release contains three folders: bridge, FwImage, and internal.

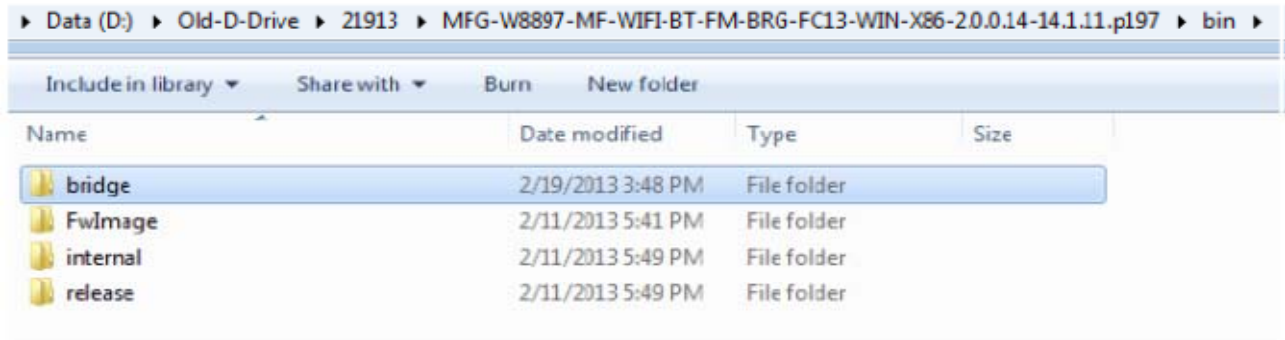

## (3) Bridge Folder

Within the bridge folder are two .tgz files.

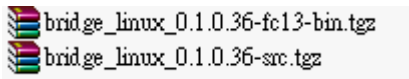

a. File bridge\_linux\_0.1.0.29-fc13-bin contains the following files.

Name	Size	Packed	Type	Modified	CRC32
..			File folder		
bridge_init.conf	866	?	CONF File	12/10/2012 3:4...	
mfgbridge	84,472	?	File	12/10/2012 3:4...	

b. File bridge\_linux\_0.1.0.22-src.tgz contains the source files for the bridge.

..				
Android.mk	381	?		
Android_bz.mk	381	?		
Android_mbt.mk	275	?		
bridge_init.conf	856	?		
load.sh	77	?		
Makefile	1,131	?		
mfgbridge.c	32,136	?		
mfgbridge.h	5,193	?		
mfgdebug.c	2,112	?		
mfgdebug.h	2,008	?		
README.txt	386	?		
unload.sh	24	?		

(4)FwImage Folder

Within the FwImage folder are 15 .bin files.

pcie8897_uart_combo.bin	565,764	381,436
pcie8897_uart_combo.h	3,394,615	600,363
pcie8897_usb_combo.bin	583,560	394,580
pcie8897_usb_combo.h	3,501,391	620,882
sdio8897_sdio_combo.bin	553,488	378,585
sdio8897_sdio_combo.h	3,320,959	595,076
sdio8897_uart_combo.bin	554,028	378,678
sdio8897_uart_combo.h	3,324,199	595,046
usb8897_uart_combo.bin	575,728	393,335
usb8897_uart_combo.h	3,454,399	618,791
w8897d_PCIE_UART_UART.bin	311,644	211,115
w8897d_PCIE_USB_USB.bin	329,440	224,032
w8897d_SDIO_SDIO_SDIO.bin	311,104	211,017
w8897d_SDIO_UART_UART.bin	311,644	211,116
w8897d_USB_UART_UART.bin	311,644	211,116
w8897o_PCIE_UART_UART.bin	254,120	170,382
w8897o_PCIE_USB_USB.bin	254,120	170,382
w8897o_SDIO_SDIO_SDIO.bin	242,384	167,436
w8897o_SDIO_UART_UART.bin	242,384	167,437
w8897o_USB_UART_UART.bin	264,084	182,085

a. The corresponding Firmware should be placed in the /lib/Firmware/mrvl folder

(5)Internal Folder

Within the internal folder is the labtool and labtool\_src folder. For this document’s purpose, only the details of the labtool folder will be discussed.

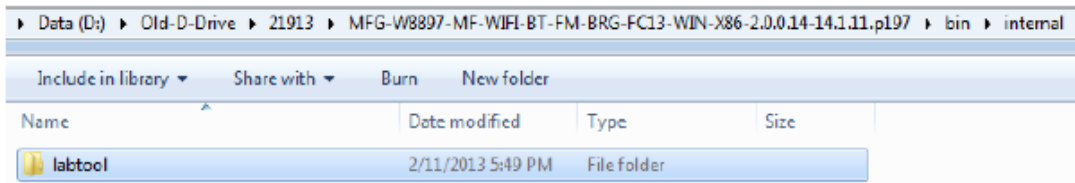

The contents of the labtool folder is shown below.

Name	Date modified	Type	Size
AddCalDLL.dll	2/11/2013 5:46 PM	Application extens...	1,004 KB
DutApi878XDII.h	2/11/2013 5:46 PM	H File	41 KB
DutApiMimoBtFmBrdigeEth	2/11/2013 5:48 PM	Application	192 KB
DutApiMimoBtFmBrdigeUart	2/11/2013 5:48 PM	Application	144 KB
DutApiMimoBtFmDII_BRIDGE_ETH.dll	2/11/2013 5:47 PM	Application extens...	304 KB
DutApiMimoBtFmDII_BRIDGE_ETH.lib	2/11/2013 5:47 PM	LIB File	129 KB
DutApiMimoBtFmDII_BRIDGE_UART.dll	2/11/2013 5:48 PM	Application extens...	316 KB
DutApiMimoBtFmDII_BRIDGE_UART.lib	2/11/2013 5:48 PM	LIB File	129 KB
DutBtApi.hc	2/11/2013 5:46 PM	HC File	7 KB
DutBtApi878XDII.h	2/11/2013 5:46 PM	H File	20 KB
DutFmApi878XDII.h	2/11/2013 5:46 PM	H File	13 KB
DutWlanApi.hc	2/11/2013 5:46 PM	HC File	15 KB
DutWlanApi878XDII.h	2/11/2013 5:46 PM	H File	25 KB
Flash_SPI_header.bin	2/11/2013 5:46 PM	BIN File	4 KB
Flash_SPI_header.sbin	2/11/2013 5:46 PM	SBIN File	4 KB
GenHeader.bin	2/11/2013 5:46 PM	BIN File	1 KB
SetUp	2/11/2013 5:46 PM	Configuration sett...	3 KB
UsbHeader.bin	2/11/2013 5:46 PM	BIN File	1 KB

The Labtool executable is labeled (DutApiMimoBtFmBridgeEth.exe)

## 1.2 Using the Contents of the MFG Release Package

(1) For the Bridge Utility that runs on the target platform, go to the folder shown below.

► Data (D:) ► Old-D-Drive ► 21913 ► MFG-W8897-MF-WIFI-BT-FM-BRG-FC13-WIN-X86-2.0.0.14-14.1.11.p197 ► bin ►

Name	Date modified	Type	Size
bridge	2/19/2013 3:48 PM	File folder	
FwImage	2/11/2013 5:41 PM	File folder	
internal	2/11/2013 5:49 PM	File folder	
release	2/11/2013 5:49 PM	File folder	

Obtain the bridge\_linux\_x.x.x.x\_src.tgz file. The source files include a makefile for standard Linux distribution and Android. The same bridge tool can be compiled and run on an Android platform.

After successful compilation, an “mfgbridge” executable will be produced and will run on the target platform. In the same folder, make sure to include the bridge\_init.conf file from the bridge source code.

On the given Host Linux system, the following files have to be transferred & reside on the system. (Transfer the files over via flash memory or tftp over the host.)

Place the firmware in /lib/firmware/mrvl/  
 pcie8897\_usb\_combo.bin

**PLEASE NOTE THE DRIVER IS NOT PART OF THE MANUFACTURING PACKAGE**

The user must compile the driver per your specific Linux OS and Kernel. This is due to that the driver is dependent on the actual OS and kernel version. This next section will describe the steps needed to be done before you can install the driver and run it.

Please download the production driver package from the extranet at the below location:

My Products/ Wireless/ 88W8897/ Software

Unzip these three zipped files:

a. XXX-8897-FC13-X86-X.X.X.X\_X-app-src.tgz

b. XXX-8897-FC13-X86-X.X.X.X\_X-GPL-src.tgz

c. XXX-8897-FC13-X86-X.X.X.X\_X-mlan-src.tgz

From the unzipped files, go to the subdirectory wlan\_src

\*Make sure to have kernel headers and kernel libs before executing the “make” commands below.

```
make clean
```

```
make build
```

Go up one folder to copy both \*.ko files to your directory in where you have the other files in where you want to run the insmod command.

Here is the sample list of files (as a minimum) at 1 location:

bridge\_init.conf

mfgbridge

mlan.ko

pcie8897.ko

Now you can run the following commands to install the driver and firmware and start the Manufacturing bridge application with the following commands.

On the target platform, use the following commands to put the 88W8897 in MFG mode:

```
>insmod mlan.ko
```

```
>insmod pcie8897.ko mfg_mode=1 fw_name=mrwl/pcie8897_usb_combo.bin
```

Bring up the ethernet interface and specify an IP address to the Target platform. This address must match the IP for the DUT in which the Host XP is expecting.

**Ex. `ifconfig eth0 192.168.1.10 up`**

The next line will start the MFG Bridge application.

**`>./mfgbridge`**

At this point, the target is ready to receive Labtool commands. On the Windows XP laptop where the Labtool release was downloaded, go to the folder shown below:

F:\X86-1.0.1.14-14.0.11.p5\bin\internal\labtool

Name	Size	Type	Date Modified
DutApi878xDll.h	37 KB	C/C++ Header	3/28/2011 2:09 PM
DutApiMimoBtFmBridgeEth.exe	212 KB	Application	3/28/2011 2:10 PM
DutApiMimoBtFmBridgeUart.exe	176 KB	Application	3/28/2011 2:10 PM
DutApiMimoBtFmDll_BRIDGE_...	288 KB	Application Extension	3/28/2011 2:10 PM
DutApiMimoBtFmDll_BRIDGE_...	118 KB	Object File Library	3/28/2011 2:10 PM
DutApiMimoBtFmDll_BRIDGE_...	296 KB	Application Extension	3/28/2011 2:10 PM
DutApiMimoBtFmDll_BRIDGE_...	119 KB	Object File Library	3/28/2011 2:10 PM
DutBtApi878xDll.h	20 KB	C/C++ Header	3/28/2011 2:09 PM
DutBtApi.hc	7 KB	HC File	3/28/2011 2:09 PM
DutFmApi878xDll.h	13 KB	C/C++ Header	3/28/2011 2:09 PM
DutWlanApi878xDll.h	27 KB	C/C++ Header	3/28/2011 2:09 PM
DutWlanApi.hc	14 KB	HC File	3/28/2011 2:09 PM
FEM_8797.ini	2 KB	Configuration Settings	3/28/2011 2:09 PM
GenHeader.bin	1 KB	BIN File	3/28/2011 2:09 PM
SetUp.ini	32 KB	Configuration Settings	3/28/2011 2:09 PM
UsbHeader.bin	1 KB	BIN File	3/28/2011 2:09 PM

Edit the “SetUp.ini” file as shown in the lines highlighted in **RED** below. The setup DutIpAddress will be the IP address of your target.

**HostIpAddress** will be the IP address of the Windows XP Laptop.

```
[DutIp]
DutIpAddress = 192.168.1.10
HostIpAddress = 192.168.1.100
Protocol = TCP
```

Click on “**DutApiMimoBtFmBridgeEth.exe**” and you will see

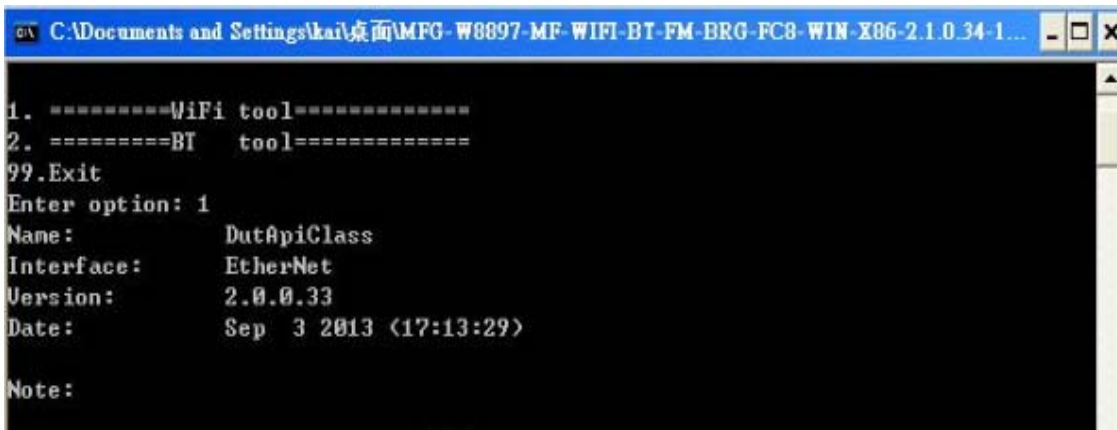

### 1.3 Initial Command

As the information showed on your screen, please enter these commands below to start your test.  
(Figure 9)

**Command: 1** Wi-Fi testing

**Command: 2** BT testing

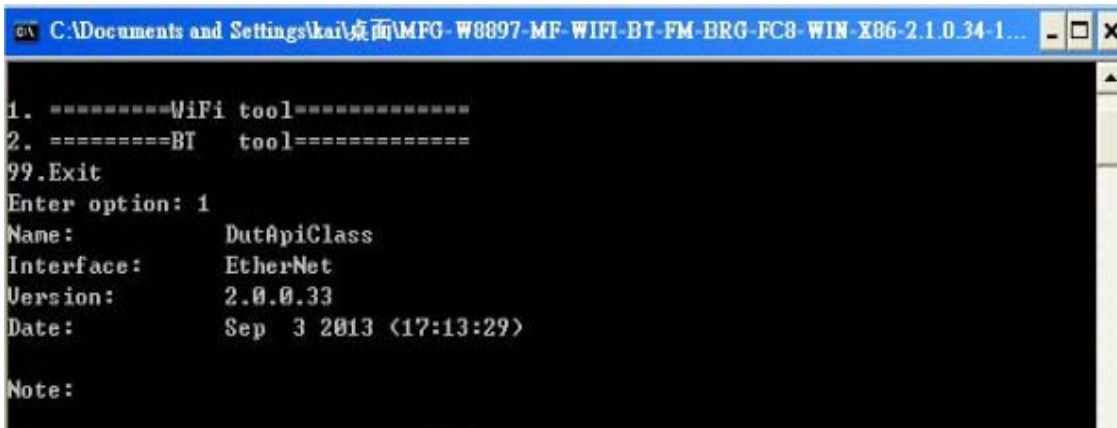

Figure 9

### 1.3 Generate 802.11a/b/g/n Packet commands

a. Tx on CH 6 at 10 dBm with a CCK-11Mbps data rate in 20 MHz BW mode on path A

```

25           // Stop Tx
10 1 1       // Set Path A Only
30 0         // Set to 2.4 GHz Band
112 0       // Set to 20 MHz BW
12 6         // Set to CH 6
  
```



22 0 6 10 0 // Set to CH 6 at 10 dBm Output Power with CCK/BPSK Data Rate on Path A

25 1 4 // Tx at 11 Mbps

---

b. Tx on CH 6 at 10 dBm with a CCK-11Mbps data rate in 20 MHz BW mode on path B

25 // Stop Tx

10 2 2 // Set Path B Only

30 0 // Set to 2.4 GHz Band

112 0 // Set to 20 MHz BW

12 6 // Set to CH 6

22 1 6 10 0 // Set to CH 6 at 10 dBm Output Power with CCK/BPSK Data Rate on Path B

25 1 4 // Tx at 11 Mbps

---

c. Tx on CH 36 at 8 dBm with a MCS7 Data rate in 20 MHz BW Mode on Path A

25 // Stop Tx

10 1 1 // Set Path A

30 1 // Set to 5 GHz Band

112 0 // Set to 20 MHz BW

12 36 // Set to CH 36

22 0 36 8 1 // Set to CH 36 at 8 dBm Output Power with OFDM Data Rate on Path A

25 1 22 // Tx at MCS 7

---

d. Tx on CH 36 at 12 dBm with a MCS7 Data rate in 40 MHz BW Mode on Path A

25 // Stop Tx

10 1 1 // Set Path A

30 1 // Set to 5 GHz Band

112 1 // Set to 40 MHz BW

12 36 // Set to CH 36.

22 0 36 12 1 // Set to CH 36 at 12 dBm Output Power with OFDM Data Rate on path A

25 1 22 // Tx at MCS 7

---

d. Tx on CH 36(5210MHz) at 11 dBm with a MCS9 Data rate in 80 MHz BW Mode on Path A

```

25 // Stop Tx

10 1 1 // Set Path A
30 1 // Set to 5 GHz Band
112 4 // Set to 40 MHz BW
12 36 // Set to CH 36.
22 0 36 11 1 // Set to CH 36 at 11 dBm Output Power with OFDM Data Rate on path A
25 1 110 // Tx at MCS 9
  
```

**Data rate set up**

**B mode & G mode:**

1Mbps	5.5Mbps	11Mbps	6Mbps	9Mbps	12Mbps	18Mbps	24Mbps
1	3	4	6	7	8	9	10
36Mbps	48Mbps	54Mbps					
11	12	13					

**N mode:**

MCS0	MCS1	MCS2	MCS3	MCS4	MCS5	MCS6	MCS7	
15	16	17	18	19	20	21	22	

**VHT Data Rates:**

- 101 for VHT\_SS1\_MCS0
- 102 for VHT\_SS1\_MCS1
- 103 for VHT\_SS1\_MCS2
- 104 for VHT\_SS1\_MCS3
- 105 for VHT\_SS1\_MCS4
- 106 for VHT\_SS1\_MCS5
- 107 for VHT\_SS1\_MCS6
- 108 for VHT\_SS1\_MCS7
- 109 for VHT\_SS1\_MCS8
- 110 for VHT\_SS1\_MCS9
- 111 for VHT\_SS2\_MCS0
- 112 for VHT\_SS2\_MCS1
- 113 for VHT\_SS2\_MCS2
- 114 for VHT\_SS2\_MCS3
- 115 for VHT\_SS2\_MCS4

116 for VHT\_SS2\_MCS5

117 for VHT\_SS2\_MCS6

118 for VHT\_SS2\_MCS7

119 for VHT\_SS2\_MCS8

120 for VHT\_SS2\_MCS9

After you type above command, you can measure the 802.11b/g/n packet by your RF test instrument (exp: Agilent 4010, IQview...).

## 1.4 Generate 802.11b/g/n continuous symbol Commands

a. Cont. Tx on CH 36 at 8 dBm with a MCS7 Data rate in 20 MHz BW Mode on Path A

```
17          // Stop Cont. Tx
25          // Stop Tx
10 1 1      // Set Path A
30 1        // Set to 5 GHz Band
112 0       // Set to 20 MHz BW
12 36       // Set to CH 36
22 0 36 8 1 // Set to CH 36 at 8 dBm Output Power with OFDM Data Rate on Path A
25 1 22     // Tx at MCS 7
25          // Stop Tx
17 1 22     // Cont. Tx at MCS7
17          // Stop Cont. Tx
```

## 1.5 Test RX sensitivity Commands

a. Rx on CH 157 in 20 MHz BW Mode on both Path A

```
25          // Stop Tx
10 1 1      // Set to Path A
30 1        // Set to 5 GHz Band
112 0       // Set to 20 MHz BW
12 100      // Set to CH 100
31          // Clear all the received packets
32          // Get Rx Packet Count and then clear the Rx packet counter
```

## 1.6 Others Commands

- (1) **Command 45**→ Check the MAC
- (2) **Command 99**→ Quit the test mode/ Quit the MFG tool

## 1.7 BT test mode Commands

This is how we test our BT: let BT enter test mode, then connect to tester for testing.

- (1) Command 45→Check BT MAC.
- (2) Command 78 1→BT enter test mode.

After you type above command, you can measure BT signal both TX/RX and the other BT test items by your BT instrument.

## **Federal Communication Commission Interference Statement**

This device complies with Part 15 of the FCC Rules. Operation is subject to the following two conditions: (1) This device may not cause harmful interference, and (2) this device must accept any interference received, including interference that may cause undesired operation.

This equipment has been tested and found to comply with the limits for a Class B digital device, pursuant to Part 15 of the FCC Rules. These limits are designed to provide reasonable protection against harmful interference in a residential installation. This equipment generates, uses and can radiate radio frequency energy and, if not installed and used in accordance with the instructions, may cause harmful interference to radio communications. However, there is no guarantee that interference will not occur in a particular installation. If this equipment does cause harmful interference to radio or television reception, which can be determined by turning the equipment off and on, the user is encouraged to try to correct the interference by one of the following measures:

- Reorient or relocate the receiving antenna.
- Increase the separation between the equipment and receiver.
- Connect the equipment into an outlet on a circuit different from that to which the receiver is connected.
- Consult the dealer or an experienced radio/TV technician for help.

FCC Caution: Any changes or modifications not expressly approved by the party responsible for compliance could void the user's authority to operate this equipment.

This transmitter must not be co-located or operating in conjunction with any other antenna or transmitter.

**Operations in the 5.15-5.25GHz band are restricted to indoor usage only.**

**Radiation Exposure Statement:**

This equipment complies with FCC radiation exposure limits set forth for an uncontrolled environment. This equipment should be installed and operated with minimum distance 20cm between the radiator & your body.

**This device is intended only for OEM integrators under the following conditions:**

- 1) The antenna must be installed such that 20 cm is maintained between the antenna and users, and
- 2) The transmitter module may not be co-located with any other transmitter or antenna.

As long as **2** conditions above are met, further transmitter test will not be required. However, the OEM integrator is still responsible for testing their end-product for any additional compliance requirements required with this module installed

**IMPORTANT NOTE:** In the event that these conditions can not be met (for example certain laptop configurations or co-location with another transmitter), then the FCC authorization is no longer considered valid and the FCC ID can not be used on the final product. In these circumstances, the OEM integrator will be responsible for re-evaluating the end product (including the transmitter) and obtaining a separate FCC authorization.

**End Product Labeling**

This transmitter module is authorized only for use in device where the antenna may be installed such that 20 cm may be maintained between the antenna and users. The final end product must be labeled in a visible area with the following: “Contains FCC ID: **TLZ-CB178NF**. The grantee's FCC ID can be used only when all FCC compliance requirements are met.

**Manual Information To the End User**

The OEM integrator has to be aware not to provide information to the end user regarding how to install or remove this RF module in the user’s manual of the end product which integrates this module.

The end user manual shall include all required regulatory information/warning as show in this manual.

### **Industry Canada statement:**

This device complies with RSS-210 of the Industry Canada Rules. Operation is subject to the following two conditions: (1) This device may not cause harmful interference, and (2) this device must accept any interference received, including interference that may cause undesired operation.

Ce dispositif est conforme à la norme CNR-210 d'Industrie Canada applicable aux appareils radio exempts de licence. Son fonctionnement est sujet aux deux conditions suivantes: (1) le dispositif ne doit pas produire de brouillage préjudiciable, et (2) ce dispositif doit accepter tout brouillage reçu, y compris un brouillage susceptible de provoquer un fonctionnement indésirable.

### **Radiation Exposure Statement:**

This equipment complies with IC radiation exposure limits set forth for an uncontrolled environment. This equipment should be installed and operated with minimum distance 20cm between the radiator & your body.

### **Déclaration d'exposition aux radiations:**

Cet équipement est conforme aux limites d'exposition aux rayonnements IC établies pour un environnement non contrôlé. Cet équipement doit être installé et utilisé avec un minimum de 20 cm de distance entre la source de rayonnement et votre corps.

### **Radiation Exposure Statement:**

This equipment complies with IC radiation exposure limits set forth for an uncontrolled environment. This equipment should be installed and operated with minimum distance 20cm between the radiator & your body.

### **Déclaration d'exposition aux radiations:**

Cet équipement est conforme aux limites d'exposition aux rayonnements IC établies pour un environnement non contrôlé. Cet équipement doit être installé et utilisé avec un minimum de 20 cm de distance entre la source de rayonnement et votre corps.

**This device is intended only for OEM integrators under the following conditions: (For module device use)**

- 1) The antenna must be installed such that 20 cm is maintained between the antenna and users, and
- 2) The transmitter module may not be co-located with any other transmitter or antenna.

As long as **2** conditions above are met, further transmitter test will not be required. However, the OEM integrator is still responsible for testing their end-product for any additional compliance requirements required with this module installed.

**Cet appareil est conçu uniquement pour les intégrateurs OEM dans les conditions suivantes: (Pour utilisation de dispositif module)**

- 1) L'antenne doit être installée de telle sorte qu'une distance de 20 cm est respectée entre l'antenne et les utilisateurs, et
- 2) Le module émetteur peut ne pas être coïmplanté avec un autre émetteur ou antenne.

Tant que les **2** conditions ci-dessus sont remplies, des essais supplémentaires sur l'émetteur ne seront pas nécessaires. Toutefois, l'intégrateur OEM est toujours responsable des essais sur son produit final pour toutes exigences de conformité supplémentaires requis pour ce module installé.

**IMPORTANT NOTE:**

In the event that these conditions can not be met (for example certain laptop configurations or co-location with another transmitter), then the Canada authorization is no longer considered valid and the IC ID can not be used on the final product. In these circumstances, the OEM integrator will be responsible for re-evaluating the end product (including the transmitter) and obtaining a separate Canada authorization.

**NOTE IMPORTANTE:**

Dans le cas où ces conditions ne peuvent être satisfaites (par exemple pour certaines configurations d'ordinateur portable ou de certaines co-localisation avec un autre émetteur), l'autorisation du Canada n'est plus considéré comme valide et l'ID IC ne peut pas être utilisé sur le produit final. Dans ces circonstances, l'intégrateur OEM sera chargé de réévaluer le produit final (y compris l'émetteur) et l'obtention d'une autorisation distincte au Canada.

**End Product Labeling**

This transmitter module is authorized only for use in device where the antenna may be installed such that 20 cm may be maintained between the antenna and users. The final end product must be labeled in a visible area with the following: "Contains IC:



6100A-CB178NF”.

### **Plaque signalétique du produit final**

Ce module émetteur est autorisé uniquement pour une utilisation dans un dispositif où l'antenne peut être installée de telle sorte qu'une distance de 20cm peut être maintenue entre l'antenne et les utilisateurs. Le produit final doit être étiqueté dans un endroit visible avec l'inscription suivante: "Contient des IC: 6100A-CB178NF".

### **Manual Information To the End User**

The OEM integrator has to be aware not to provide information to the end user regarding how to install or remove this RF module in the user's manual of the end product which integrates this module.

The end user manual shall include all required regulatory information/warning as show in this manual.

### **Manuel d'information à l'utilisateur final**

L'intégrateur OEM doit être conscient de ne pas fournir des informations à l'utilisateur final quant à la façon d'installer ou de supprimer ce module RF dans le manuel de l'utilisateur du produit final qui intègre ce module.

Le manuel de l'utilisateur final doit inclure toutes les informations réglementaires requises et avertissements comme indiqué dans ce manuel.

### **Caution :**

- (i) the device for operation in the band 5150-5250 MHz is only for indoor use to reduce the potential for harmful interference to co-channel mobile satellite systems;
- (ii) the maximum antenna gain permitted for devices in the bands 5250-5350 MHz and 5470-5725 MHz shall comply with the e.i.r.p. limit; and
- (iii) the maximum antenna gain permitted for devices in the band 5725-5825 MHz shall comply with the e.i.r.p. limits specified for point-to-point and non point-to-point operation as appropriate.
- (iv) Users should also be advised that high-power radars are allocated as primary users (i.e. priority users) of the bands 5250-5350 MHz and 5650-5850 MHz and that these radars could cause interference and/or damage to LE-LAN devices.

### **Avertissement:**

Le guide d'utilisation des dispositifs pour réseaux locaux doit inclure des instructions précises sur les restrictions susmentionnées, notamment :

- (i) les dispositifs fonctionnant dans la bande 5 150-5 250 MHz sont réservés uniquement pour une utilisation à l'intérieur afin de réduire les risques de brouillage préjudiciable aux systèmes de satellites mobiles utilisant les mêmes canaux;
- (ii) le gain maximal d'antenne permis pour les dispositifs utilisant les bandes 5 250-5 350 MHz et 5 470-5 725 MHz doit se conformer à la limite de p.i.r.e.;
- (iii) le gain maximal d'antenne permis (pour les dispositifs utilisant la bande 5 725-5 825 MHz) doit se conformer à la limite de p.i.r.e. spécifiée pour l'exploitation point à point et non point à point, selon le cas.
- (iv) De plus, les utilisateurs devraient aussi être avisés que les utilisateurs de radars de haute puissance sont désignés utilisateurs principaux (c.-à-d., qu'ils ont la priorité) pour les bandes 5 250-5 350 MHz et 5 650-5 850 MHz et que ces radars pourraient causer du brouillage et/ou des dommages aux dispositifs LAN-EL.

## **低功率電波輻射性電機管理辦法**

第十二條 經型式認證合格之低功率射頻電機，非經許可，公司、商號或使用者均不得擅自變更頻率、加大功率或變更原設計之特性及功能。

第十四條 低功率射頻電機之使用不得影響飛航安全及干擾合法通信；經發現有干擾現象時，應立即停用，並改善至無干擾時方得繼續使用。

前項合法通信，指依電信法規定作業之無線電通信。

低功率射頻電機須忍受合法通信或工業、科學及醫療用電波  
輻射性電機設備之干擾。

**模組認證：**

1. 本模組於取得認證後將依規定於模組本體標示審驗合格標籤。

2. 系統廠商應於平台上標示「本產品內含射頻模組：

XXXyyyLPDzzzz-x」字樣。