

Beckett

PARTS & ACCESSORIES

GeniSys™

Model 7505 Advanced Burner Control



Description / Applications

The Beckett GeniSys™ Advanced Burner Control is a 120 Vac primary safety control for residential and light commercial oil burners used in boiler, furnace, and water heater applications having firing rates less than 20 GPH. The GeniSys is used with a suitable cad cell flame sensor to control the oil burner motor, igniter, and optional solenoid valve. It has 24 Vac thermostat terminals (if applicable) compatible with both mechanical and many power stealing thermostats. It can provide interrupted or intermittent duty ignition, and it has a 30 second lockout time on recycle.

GeniSys



Features

- Thermostat / Operating (if applicable) and Limit Control Compatible
- Welded Relay Protection
- Limited Recycle
- Limited Reset
- 3 Status Lights
- Valve-On Delay / Motor-Off Delay (Field programmable with Beckett add-on Display)
- 15 Second Lockout Time
- Interrupted or Intermittent Duty Ignition
- Technician Pump Priming Mode
- Disable Function
- Cad Cell Resistance Indicator
- Communication Ports (2)

Specifications

Electrical Ratings

Inputs:

- Voltage: 5 Vdc \pm 4%
- Current: 25 mA maximum display current

Environmental Ratings:

- Storage Ambient Temperature: -22°F to +150°F (-35°C to +65°C)
- Operating Ambient Temperature: -4°F to +150°F (-20°C to +65°C)
- Moisture: 5 to 85% RH, non-condensing and non-crystallizing

Table 1 - Models and Cross Reference Guide

Beckett GeniSys™ Control Part No.	Lockout Time	Valve-on delay time ²	Motor-off delay time ²	Replaces Honeywell:	Replaces Carlin:
7505A 0000	15 sec	-	-	R7184A, R8184G	48245, 40200, 42230, 50200 ¹
7505B 1500	15 sec	15 sec	-	R7184B	-
7505P 1515	15 sec	15 sec	15 sec	R7184P, R7184U ¹	60200 ¹
7505P 1530	15 sec	15 sec	30 sec	R7184P, R7184U ¹	60200 ¹
7505P 152M	15 sec	15 sec	2 min	R7184P, R7184U ¹	60200 ¹

- 1 Beckett snap-on alarm module required for direct replacement of this control.
- 2 Valve-on delay and motor-off delay timings on all models are programmable with Beckett snap-on programming display. Other factory set timings are available. Contact Beckett for alternate timings.

Figure 1 – Getting to know the control

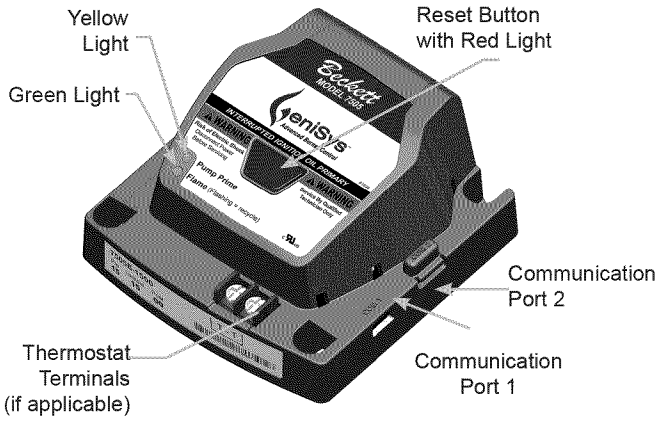

Optional Snap-on Display Module: For programming and diagnostics

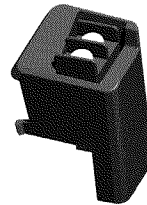
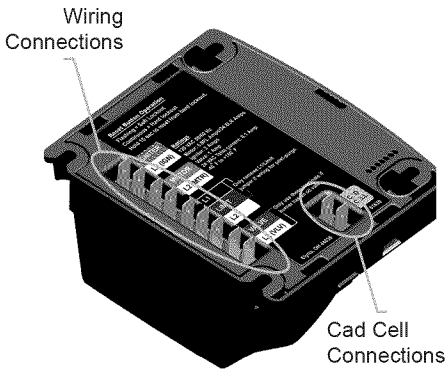

Optional Snap-on Alarm Module: For adding isolated low voltage alarm contacts to the base control. See Alarm Module Instructions for specifications.



CAUTION Do Not Use This Control in an Application

that is Not Within the Ratings Listed in This Section. Improper Control Operation May Result.

Electrical Ratings

Inputs:

- Voltage: 120 Vac nominal (102 to 132 Vac)
- Current: 100 mA nominal (150 mA max at 132 Vac)
- Frequency: 60 Hz

Outputs:

- Motor: 120 Vac, 10 full load amps (FLA), 60 locked rotor amps (LRA)
*Note: Reduce motor FLA rating by igniter current
- Igniter: 120 Vac, 3 A @ 0.7 PF min
- Solenoid Valve: 120 Vac, 1 A @ 0.7 PF min
- Thermostat Anticipator Current: 0.1 A (if applicable)
- Thermostat Voltage: 24 Vac (if applicable)

Environmental Ratings:

- Storage and Operating Ambient Temperature: -40°F to +150°F (-40°C to +65°C)
- Moisture: 5 to 95% RH, non-condensing and non-crystallizing

Approvals:

- Underwriters Laboratory Recognition per UL372 and UL1998, and CSA C22.2 No. 199



CAUTION Do Not Use This Control Above 19.9 GPH

Most codes and standards require additional safeguards and features for oil burner inputs above 19.9 gph. Consult the appliance manufacturer's instructions for control selection.

Installation/Operation/Maintenance



WARNING Professional Service Required



Incorrect installation or misuse of this control could result in severe personal injury, death, or substantial property damage from heavy smoke, explosion or fire.

Please read and understand the manual supplied with this control. This control must be installed, adjusted and put into operation only by a qualified individual or service agency that is:

- Licensed or certified to install and provide technical service to oil heating systems.
- Experienced with all applicable codes, standards and ordinances.
- Responsible for the correct installation and commission of this equipment.
- Skilled in the adjustment of oil burners using combustion test instruments.

The installation must strictly comply with all applicable codes, authorities having jurisdiction and the latest revision of the National Fire Protection Association Standard for the Installation of Oil-Burning Equipment, NFPA 31 (or CSA-B139 and CSA-B140 in Canada).

Regulation by these authorities take precedence over the general instructions provided in this installation manual.



CAUTION Frozen Plumbing and Water Damage Hazard

If the residence is unattended in severely cold weather, burner primary control safety lockout, heating system component failures, power outages or other electrical system failures could result in frozen plumbing and water damage in a matter of hours. For protection, take preventive actions such as having a security system installed that operates during power outages, senses low temperature and initiates an effective action. Consult with your heating contractor or a home security agency.

WARNING Fire or Explosion Hazard



Can cause severe injury, death, or property damage.

- The control can malfunction if it gets wet, leading to accumulation of oil or explosive oil vapors.
- Never install where water can flood, drip or condense on the control.
- Never use a control that has been wet - replace it.

WARNING Electrical Shock Hazard



Electrical shock can cause severe personal injury or death.

- Disconnect **ALL** electrical power to the appliance/burner circuit before installing or servicing this control.
- Provide ground wiring to the appliance, burner and metal control mounting box.
- Perform all wiring in compliance with the National Electrical Code ANSI/NFPA 70 (Canada CSA C22.1).

WARNING Explosion, Fire, Scald, and Burn Hazard



All heating appliances must have HIGH LIMIT protection to interrupt electrical power and shutdown the burner if

operating or safety controls fail and cause a runaway condition.

- Follow the appliance manufacturer's wiring diagrams and note all required safety controls.
- Typical safety controls include high temperature or pressure limits, low water cutoffs, pressure relief valves and blocked flue vent sensing switches.
- Verify all limit and safety controls are installed and functioning correctly, as specified by the manufacturer, applicable safety standards, codes and all authorities having jurisdiction.
- Ensure that the appliance is free of oil and oil vapor before starting or resetting the burner.

CAUTION Incorrect Wiring Will Result in Improper

Control Operation

- GeniSys wiring label colors may not match the wire colors of the burner or other manufacturers' controls.
- The GeniSys Control should be wired according to the appliance manufacturer's instructions.

▪ **Mounting:**

- Mount the control on a 4" x 4" junction box on the burner, or inside the appliance cabinet. In replacement applications, mount the new control in the same location as the old control. In some replacement applications, it may be necessary to rotate the control on the 4" x 4" box for best fit.
- Mounting orientation: any orientation is acceptable.

▪ **Wiring:**

- Make sure all appliance wiring complies with all local codes and ordinances.
- Make connections to the control's terminals as shown in **Figures 2 through 9**. Refer to the label on the underside of the control for wiring details.

NOTICE

Some Thermostats Are Polarity Sensitive. Reversed polarity could cause erratic cycling of the burner control.

- Connect the wire from the R_H or R terminal on the thermostat to the TR terminal on the control (if applicable).
- Connect the wire from the W terminal on the thermostat to the TW terminal on the control (if applicable).

Typical Boiler Wiring:

Figure 2 – 7505A (for replacement of R8184G)

- Intermittent ignition, no valve-on delay, no motor-off delay

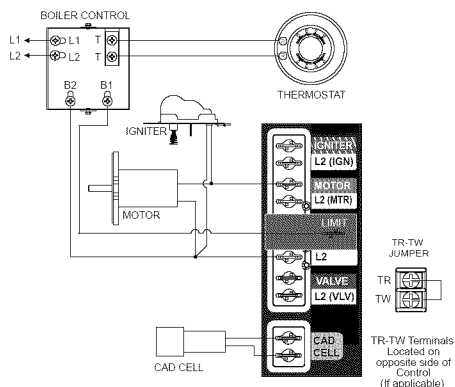

Figure 3 – 7505A (for replacement of R7184A)

- Interrupted ignition, no valve-on or motor-off delay

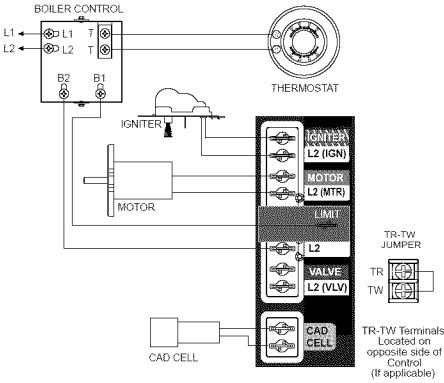

Figure 4 – 7505B (for replacement of R7184B)

- Interrupted ignition, valve-on delay only (no motor-off delay)

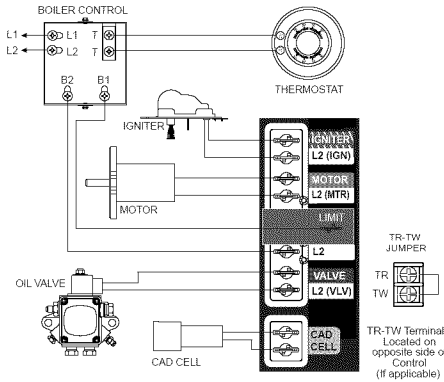
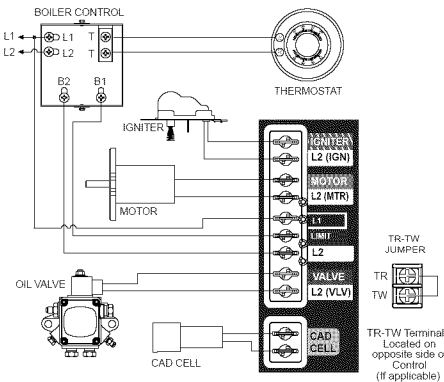

Figure 5 – 7505P (for replacement of R7184P)

- Interrupted ignition, valve-on and motor-off delays



NOTE: To disable motor-off delay on a 7505P control, jumper L1 and limit together and wire as shown in Fig. 4.

Typical Furnace Wiring:

Figure 6 – 7505A (for replacement of R8184G)

- Intermittent ignition, no valve-on or motor-off delays

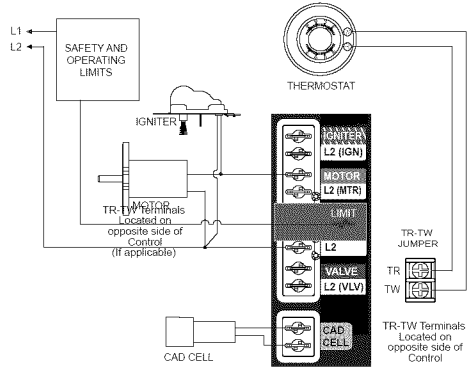

Figure 7 – 7505A (for replacement of R7184A)

- Interrupted ignition, no valve-on or motor-off delay

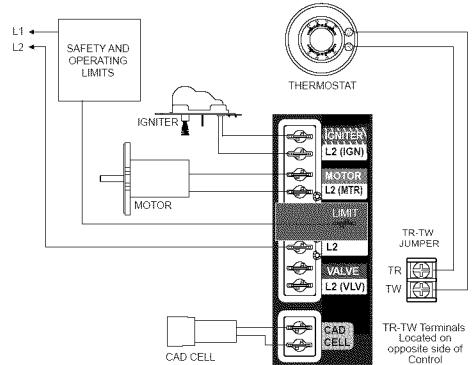

Figure 8 – 7505B (for replacement of R7184B)

- Interrupted ignition, valve-on delay only (no motor-off delay)

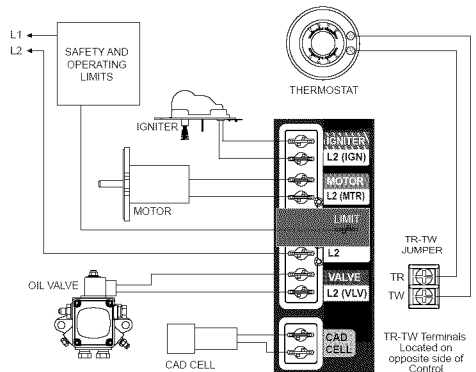
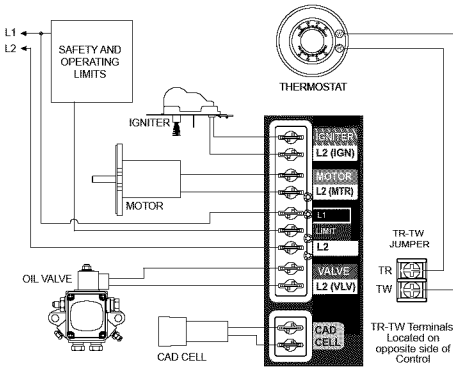

Figure 9 – 7505P (for replacement of R7184P)

- Interrupted ignition, valve-on and motor-off delays



- Note: Motor-off delay on a 7505P will be disabled if the safety and operating limits as shown in Figures 5 and 9 interrupt power to the control terminal L1.
- Connect thermostat leads (if applicable) to the TR and TW terminals on the control or jumper the TR and TW terminals on the control as directed by the appliance wiring diagram.

Note: If the thermostat short cycles or operates improperly, it may require an isolation relay for proper operation. The Beckett A/C Ready Kit (part no. 51950U) provides this function. Wiring instructions are included with the A/C Ready Kit.

Startup / Checkout

If the burner or control fails any of the following tests, recheck control wiring. If the burner or control still fails any tests, replace the control.

Starting the System

1. Open the shut-off valves in the supply line from the oil tank.
2. Close the disconnect switch to supply power to the burner.
3. Adjust the thermostat or boiler control to call for heat.
 - If the pump has not been primed, refer to “Priming the Pump” in the “Operation” section of this manual.
4. Monitor burner operation to ensure that the burner ignites.

5. End the call for heat. Verify that the burner turns off before leaving the installation site.

Check Safety Features

- Safe Start Check
 1. Place a jumper across the cad cell terminals.
 2. Refer to the steps for “Starting the System” and have the system call for heat.
 3. Burner must not start. Verify that the green light is on continuously and that the control remains in Standby mode.
 4. End the call for heat and remove the cad cell jumper.
- Simulate Flame Failure and Ignition Failure
 1. Refer to the steps for “Starting the System” and have the system call for heat.
 2. After flame is established and the burner igniter turns off, close the hand valve in the oil supply line.
 3. At flame loss, the control will enter Recycle mode. Verify that the green light is flashing. The control will remain in Recycle for 60 seconds.
 4. After the 60 second recycle period, the control will try to restart the system.
 5. After the 15 second lockout time, the control will lock out the burner and the reset button will flash. Verify that the burner motor and igniter are off and that the burner oil solenoid valve (if used) is not energized.

Operation

WARNING Fire Hazard



Reset and Service by Qualified Technician only.

6. Open the hand valve in the oil line.
7. Click the reset button and verify that the red light in the reset button shuts off and that the burner lights.
8. End the call for heat.

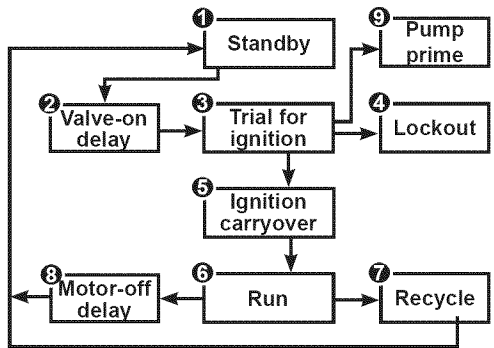

- Before leaving the installation, verify that all thermostat and boiler/furnace control wiring is correct. Consult heating appliance manual for directions.

▪ Sequence of Operation

▪ Burner States

1. **Standby:** The burner is idle, waiting for a call for heat.
2. **Valve-On Delay:** The igniter and motor are on while the control delays turning on the oil solenoid valve for the programmed time.
3. **Trial For Ignition:** The oil solenoid valve is energized. A flame should be established within the factory set trial for ignition time (“lockout time”).
4. **Lockout:** The control has shut down for one of the following safety reasons:
 - a. The trial for ignition (lockout) time expired without flame being established.
 - b. The cad cell detected flame at the end of the Valve On Delay state.

To reset the control from lockout click the button 1-second.

NOTE: A recurrence of the above failure modes or a failed welded relay check could cause the control to enter a **Hard Lockout** state that must be reset only by a qualified service technician.

To reset from Hard Lockout, hold the reset button for 15 seconds until the yellow light turns on.

5. **Ignition Carryover:** Once flame is established, the igniter remains on for 10 additional seconds to ensure flame stability.

6. **Run:** The flame is sustained until the call for heat is satisfied. The burner is then sent to Motor-Off Delay, if applicable, or it is shut down and sent to Standby.

7. **Recycle:** If the flame is lost while the burner is firing, the control shuts down the burner, enters a 60 second recycle delay, and repeats the ignition sequence. The control will continue to Recycle each time the flame is lost, until it reaches a pre-set time allotment. The control will then go into Hard Lockout instead of recycle. This feature prevents excessive accumulation of oil in the appliance firing chamber.

8. **Motor-Off Delay:** If applicable, the oil solenoid valve is turned off and the control delays turning the motor off for the set motor-off delay time before the control returns to standby.

9. **Pump Prime:** The igniter and motor are on with the oil solenoid valve energized for 4 minutes. During Pump Prime mode, the cad cell is disregarded, allowing the technician to prime the pump without having to jumper the cad cell.

▪ Reset Button Operation

- **Table 2** explains what action the control will take when the reset button is pressed for different lengths of time during the various burner operating states.

▪ Priming the Pump

1. Prepare the burner for priming by attaching a clear plastic hose over the bleed port fitting and fully opening the pump bleed port. Use a suitable container to collect purged oil.

**WARNING****Hot Gas Puff-Back and Heavy Smoke Hazard**

Failure to bleed the pump properly could result in unstable combustion, hot gas puff-back and heavy smoke.

- Do not allow oil to spray into a hot combustion chamber while bleeding air from the pump.
 - Install a gauge in the nozzle discharge port tubing or fully open the pump bleed valve to prevent oil spray from accumulating in the combustion chamber during the air bleed procedure.
 - Ensure that all bubbles and froth are purged from the oil supply system before tightening the pump bleed valve.
 - Ensure that the appliance is free of oil and oil vapor before starting or resetting the burner.
2. Initiate a call for heat.
 3. After the burner starts, press and hold the reset button for 15 seconds until the yellow light turns on. This indicates that the button has been held long enough.
 4. Release the reset button. The yellow light will turn off and the burner will start up again.
 5. At burner start up, click the reset button while the igniter is still on. This will transition the control to a dedicated Pump Prime mode, during which the motor, igniter, and valve are powered for four minutes. The yellow light will be on.
 6. Bleed the pump until all froth and bubbles are purged. If desired, terminate the call for heat or hold the reset button for at least one second to exit Pump Prime mode and return to Standby.

Table 2 - Reset Button Operation

If the burner is in the below state:	Pushing the reset button will:		
	Button Click (press < 1 second)	Button Hold (press > 1 second)	Button Hold (press 15+ seconds)
Lockout	Reset from Soft Lockout		Reset from Restricted (Hard) Lockout
Valve-on Delay, Trial for Ignition, Ignition Carryover	Go to Pump Prime (see "Priming the Pump" above)	Disable the Burner: Any time the burner is running, press and hold the reset button to disable the burner. The burner will remain off as long as the button is held.	Enables Pump Priming: After the reset button has been held for 15 seconds, the button can then be clicked during the next ignition sequence to enter Pump Prime mode.
Run (igniter is shut off)	Yellow light flashes to indicate cad cell resistance. See "Cad Cell Resistance Indicator" for table of resistance values.		
Motor-Off Delay, Standby	No action		
Pump Prime	No action	Exit Pump Prime mode and return to Standby	

Table 3 - Status Lights

Light Color	On Continuously	Flashing
Red	Restricted (Hard) Lockout	Soft Lockout
Green	Flame Sensed during normal operation (Could be stray light during standby)	Recycle
Yellow	Control is in Pump Prime mode or Reset button currently held for 15+ seconds.	Cad Cell resistance. See "Cad Cell Resistance Indicator" on page 10 for a table of resistance values.

7. At the end of 4 minutes, the yellow light will turn off and the control will automatically return to standby mode.
8. If prime is not established during the four minute pump prime mode, return to step 5 to re-enter Pump Prime mode. Repeat steps 5 through 7 until the pump is fully primed and the oil is free of bubbles.
9. Terminate the call for heat, and the control will resume normal operation.

Resetting From Restricted or Hard Lockout



WARNING

Fire & Smoke Hazard



Before starting or resetting the control from restricted lockout state, troubleshoot the heating system for the root cause(s) of the lockout.

- Make necessary repairs or adjustment to ensure a safe start condition.
- Ensure that the appliance is free of oil and oil vapors before starting or resetting the burner.

Cad Cell Resistance Indicator

- During the burner Run state, click the reset button (less than 1 second) to check the cad cell resistance range. The yellow light will flash 1 to 4 times, depending on the amount of light detected by the cad cell. See chart below:

Yellow Light Flashes	Flame Detection Range
1	Normal (0 - 400 ohms)
2	Normal (400 - 800 ohms)
3	Normal (800 - 1600 ohms)
4	Limited (1600 ohms - Lockout)

- If the control continues to lock out without a satisfied call for heat, or fails the motor relay check, the control enters Hard (restricted) Lockout in order to limit accumulation of unburned oil in the combustion chamber.
- To reset, hold the button down for 15 seconds until the red light turns off and the yellow light turns on.
- Always verify the control functions according to all specifications before leaving the installation site.
- Replace the control if it does not operate as specified.

Disable Function

- Any time the burner is running, press and hold the reset button to disable the burner. The burner will remain off as long as the button is held.

Maintenance

Oil heating systems require annual service performed by a qualified, professional service agency. The 7505 primary control should be inspected during this service routine according to the following checklist:

- **NOTE:** The 7505 control has no serviceable internal parts. Do not attempt to remove cover.
- Inspect the exterior of the control. Replace the control if there is any sign of impact damage, water or corrosion.
- Use a multimeter to test the line voltage at control L1 and L2. It should be 102 - 132 Vac.
- Inspect all external wiring for secure connections and verify insulation integrity.
- Verify the control lockout and operation sequence, (Reference *Startup/Checkout* section).
- Observe a full operating cycle to prove the sequence and timings are correct.
- Replace any control that does not meet listed specifications with an equivalent replacement unit.

R.W. Beckett Corporation

U.S.A.: P.O. Box 1289 · Elyria, Ohio 44036
www.beckettcorp.com

Canada: R.W. Beckett Canada, Ltd. · Unit #3, 430 Laird Road ·
Guelph, Ontario N1G 3X7