

1 . Dome-Light or Window Roll-Up: (•Dome-Light = 1 siren chirp / Window Roll-UP = 2 chirps)

- Configures the alarm's "Black/White" wire to operate the:

- a. Dome-Light: Supply a (-) output when the alarm is Disarmed to illuminate the vehicle's Dome-Light for 30 seconds through the use of a relay, or
- b. Window Roll-Up or accessory: Supply a (-) output for 30 seconds when the alarm is Armed to operate a Window Roll-Up module or other accessory.

2 . 3rd Channel Output: (•Momentary = 1 siren chirp / Window Roll-UP = 2 chirps)

- Configures the alarm's "Pink" wire to operate an:

- a. Accessory: Supply a (-) output as long as the small "4th" button on the remote control, is pressed & held while the vehicle's ignition is "Off", (max 30 seconds).
- b. Window Roll-Up or accessory: Supply a (-) output for 30 seconds when the alarm is Armed to operate a Window Roll-Up module or other accessory.

3. Ignition Door Lock/Unlock: (•On = 1 siren chirp / Off = 2 chirps)

- Configures the alarm to Lock the vehicle's doors when the ignition is turned "On" and Unlock the vehicle's doors when the ignition is turned "Off".

4. "RFID" Add-On to Anti-Hijacking: (On = 1 siren chirp / •Off = 2 chirps)

- Adds an "RFID" layer to both the Ignition & Open Door activated Anti-Hijacking features. (Note: Special RFID remote control required)

- Press hold TX' button 5 seconds, LED will flash, TX'RFID is turned "On".

- Press hold TX' button 5 seconds, LED will solid, TX'RFID is turned "Off".



0.80
Sec



4.0
Sec

JUMPER ON SIDE OF ALARM BRAIN:

Lock Pulse Time: (• .80 seconds = Jumper "In" / 4 seconds = Jumper "Out")

- Determines the length of the alarm's door lock/unlock pulse output.

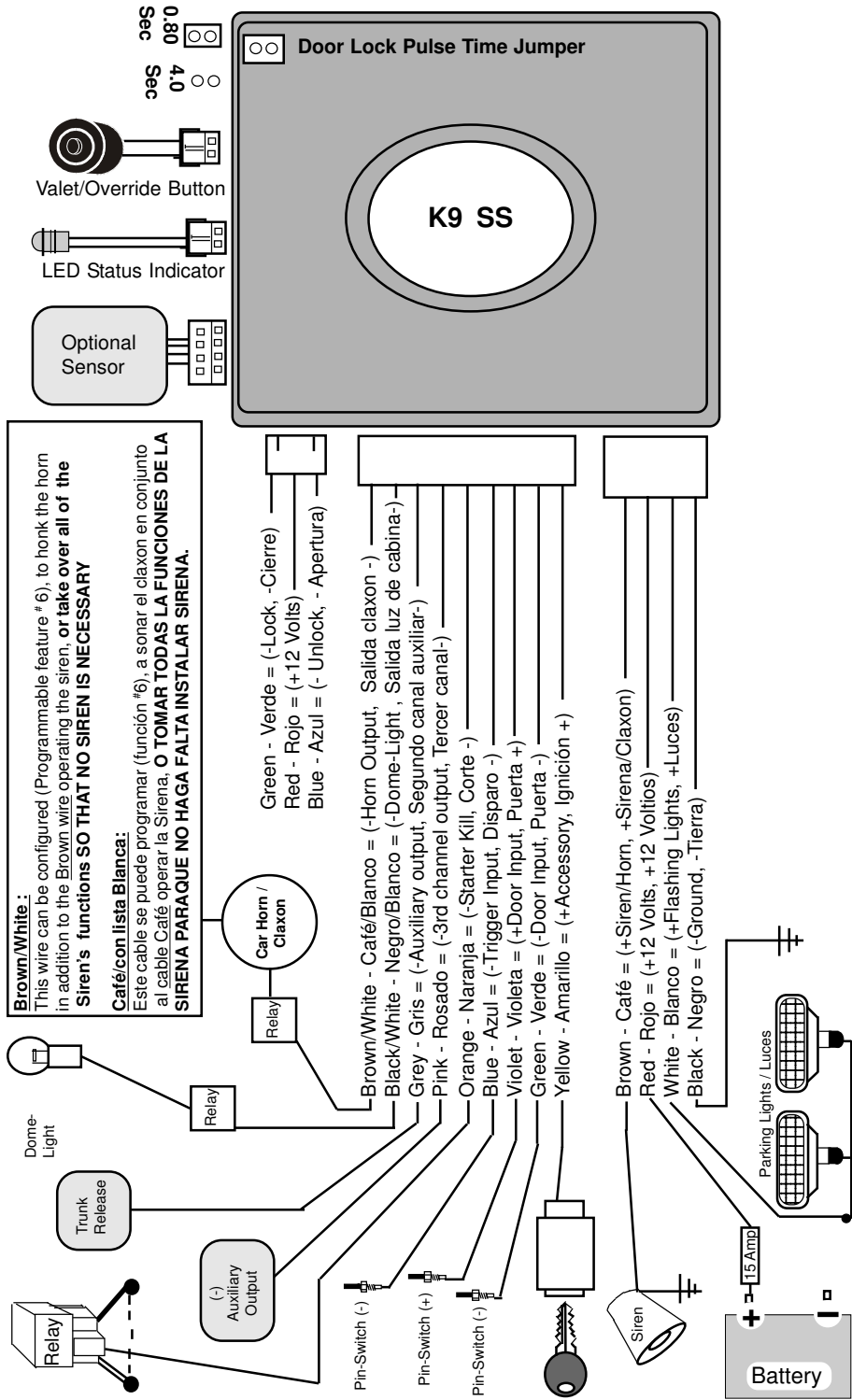

Door Locking Systems / Sistemas De Cierre

Negative Trigger System / Sistema Negativo:

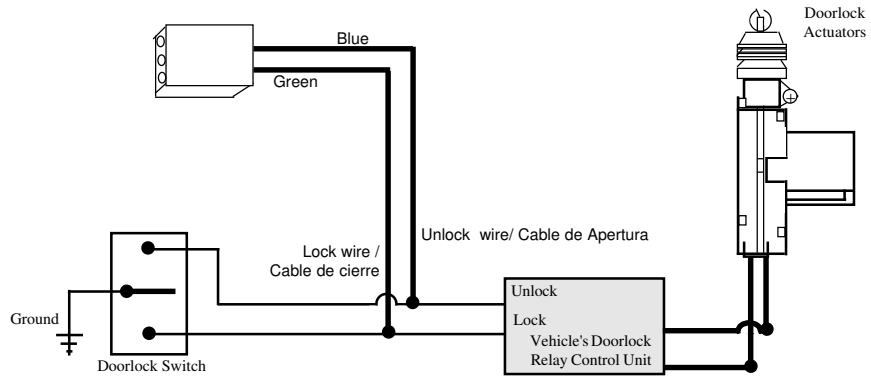

Positive Trigger System / Sistema Positivo:

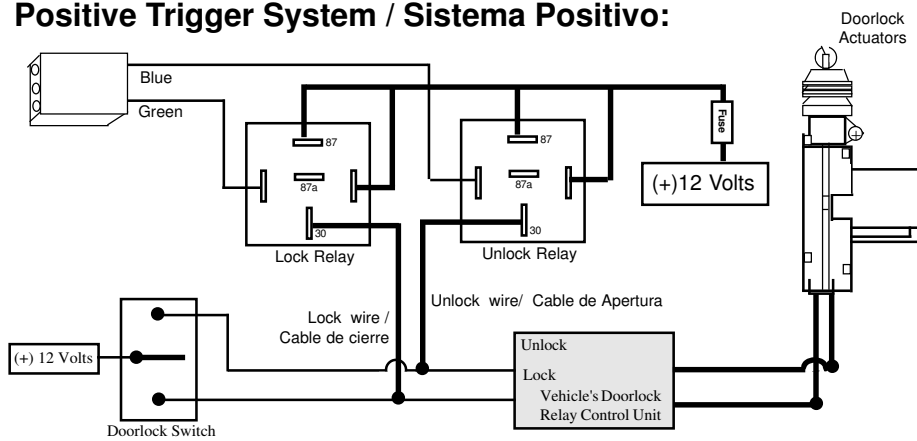

5 Wire Reversal (Rest at ground): Cambio de Polaridad:

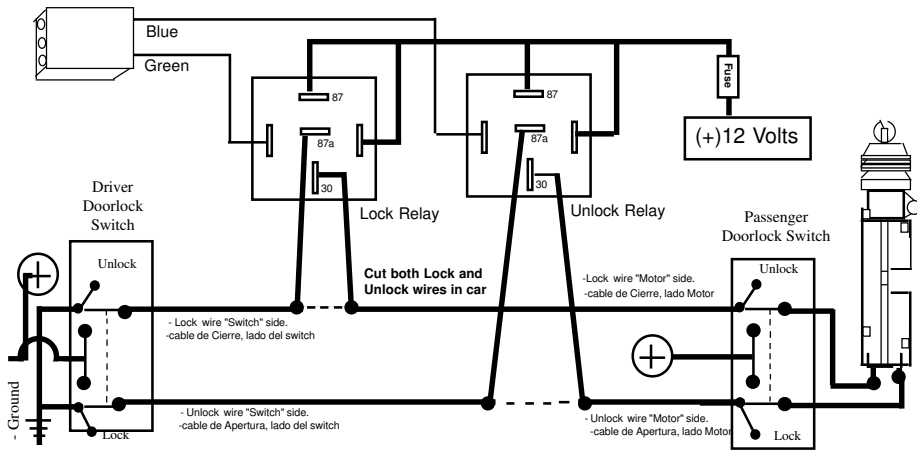

Notice : The changes or modifications not expressly approved by the party responsible for compliance could void the user's authority to operate the equipment.

IMPORTANT NOTE: To comply with the FCC RF exposure compliance requirements, no change to the antenna or the device is permitted. Any change to the antenna or the device could result in the device exceeding the RF exposure requirements and void user's authority to operate the device.

This device complies with Part 15 of the FCC Rules. Operation is subject to the following two conditions: (1) this device may not cause harmful interference, and (2) this device must accept any interference received, including interference that may cause undesired operation.