



C773 User Guide

4G LTE Broadband Wireless 11n CPE Router

Franklin Wireless C773 (O) User Guide

www.franklinwireless.com

Version 1.4.3 / 08.06.2013

© 2013 FRANKLIN . FRANKLIN and the logo are trademarks of FRANKLIN. Other marks are the property of their respective owners.



Contents

Chapter 1 C773 Overview

General Features	4
What's in the box?	4
Components	5
Service Status Indicator (LED) Description	6
Network Access	7

Chapter 2 Getting Started

Installing the 4G LTE SIM Card	8
Installing the Antenna	9
Charging the battery	9
Hooking up your telephone	11
Plug-in the Power Adapter and Turn on the device.....	11
External Antenna for Voice Call Service and GPS.....	12
Activating your device	13
Connecting to the Router	15
WPS Configuration	16
Device Specification	18

Chapter 3 Browser Interface and Settings for Wi-Fi and LAN service

Login	19
Home Screen Menu.....	19
Quick Setup Menu	20
Statistics Menu	20
WWAN Menu	21
LAN Menu	23
Wireless Menu	26
Firewall Menu	30
Content Sharing Menu	30



System Menu -----34

Chapter 4 Interface and Settings for Voice Call Service

User Menu -----35
Ring / Sound Menu -----36
Tools Menu -----37
Time Menu -----38
Setting Menu -----39

Chapter 5 Troubleshooting

Troubleshooting -----41

Chapter 6 Glossary

Glossary -----45





General Features

- 4G LTE High-Speed Wireless Data
- LAN (RJ-45) and Wi-Fi Connectivity
- Home Phone Voice Connectivity (RJ-11)
- Manage Wired and Wireless Network Activity
- An Easy-to-use web-based interface that allows you to manage, monitor, and customizes your LAN, Wi-Fi and 4G LTE connection.
- Advanced Antenna Design
- External Antenna Port for Voice Call Service and Standalone GPS

What's in the box?

The following items are included:

- C773Router
- 1050mAh Standard Lithium Ion Battery
- A/C Power Adapter
- Quick Start Guide
- RJ-45 Ethernet LAN Cable
- RJ-11 POTS Telephone Line Cable



Components

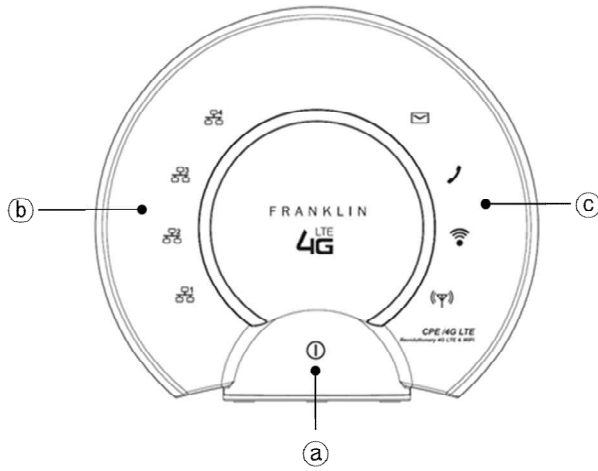

Front Panel

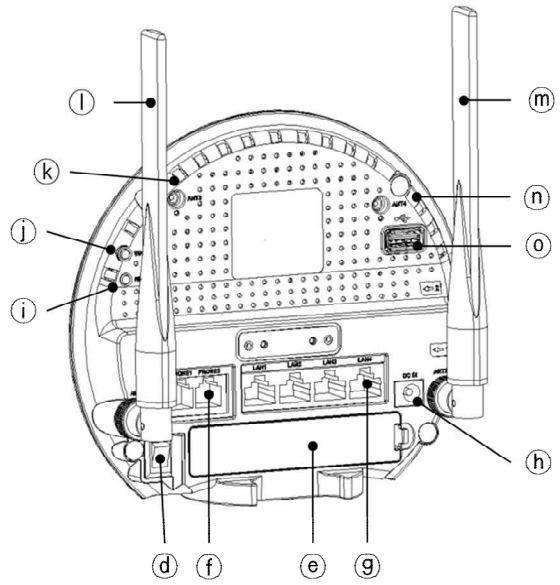

Back Panel

- Ⓐ Power LED
- Ⓑ LAN LED
- Ⓒ Voice Call & Voice Mail & Wi-Fi & LTE LED
- Ⓓ Power On/Off Button
- Ⓔ Battery Cover
- Ⓕ RJ-11 POTS Telephone Line Ports (1-2)
- Ⓖ RJ-45 Ethernet LAN Ports (1-4)
- Ⓗ A/C Power Connector
- Ⓘ Reset Button
- Ⓙ WPS Button
- Ⓚ CDMA Extension Antenna Port (MCX Connector Type)
- Ⓛ LTE Secondary Antenna
- Ⓜ LTE Primary Antenna
- Ⓝ GPS Antenna Port (MCX Connector Type)
- Ⓞ USB Port

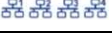

Service Status Indicator (LED) Description

No	LED Indicator			Description	Remark
	LED	Color	Solid/Blinking		
1	Power 	No Light	-	Device is powered off	
			Solid	Low battery(battery bar level = 1)	Battery is critically low. Please plug in immediately.
			Blinking	External power removed	Please plug in, otherwise battery power will be consumed.
			Solid	Low battery(battery bar level = 2)	
			Solid	Battery bar level = 3+ bars	Indicator is green when fully charged.
2	LTE 	No Light	-	Device is powered off	
			Solid	No service or Inactive	
			Solid	Week Signal	LTE service is available
		Green 	Solid	Good Signal	
3	Wi-Fi 	No light	-	Radio off	
			Blinking	In WPS operation	Used for Wi-Fi pairing.
			Solid	Radio on	
4	LAN[1..4] 	No light	-	No connected LAN users	
			Solid	Connected User	LEDs indicate whether users 1-4 are active.
5	Voice Mail 	No light	-	No voice mail	Where supported
			Solid	Voice mail is available	Where supported
6	Voice Call 	No light	-	Device is powered off	
			Solid	No service or Inactive	
			Solid	Week Signal	Voice service is available
			Blinking	Conversation in progress	
			Solid	Good Signal	
			Blinking	Conversational progress	



Network Access

- **4G Mobile Broadband with LTE***
 - Download speeds of up to 100 Mbps
 - Upload speeds of up to 50 Mbps
- **3G Mobile Broadband with EVDO Rev.***
 - Download speeds of up to 3.1 Mbps.
 - Upload speeds of up to 1.8 Mbps.
- **2G Voice Call service with 1xCDMA.***
 - Incoming and Outgoing Voice Call Service
- **Wi-Fi 802.11b/g/n**
 - 802.11b/g/n – speed of up to 11 Mbps/54 Mbps/150 Mbps

**All Speed are theoretical and are dependent on actual network conditions*



To get started, take the following steps before you set up C773.

- ① Install the 4G LTE SIM card. (See “Install the 4G LTE SIM Card”, Page 8)
- ② Install the Antennas. (See “Install the Antennas”, Page 9)
- ③ Insert and charge the battery. (See “Insert the battery”, Page 9)
- ④ Hooking up your telephone. (See “Hooking up your telephone”, Page 11)
- ⑤ Plug-in the Power Adapter and turn on the device. (See “Turn on the device”, Page 11)
- ⑥ Activating your device (See “Activating your device”, Page 13)
- ⑦ Connect the device to your computer using Wi-Fi or LAN. (See “Connecting to the Router”, Page 15)

Installing the 4G LTE SIM Card

To install your SIM card, follow these steps.

- ① Insert your SIM card into the **UPPER 2nd** slot.
- ② The SIM card **MUST** remain in the SIM card slot when in use.

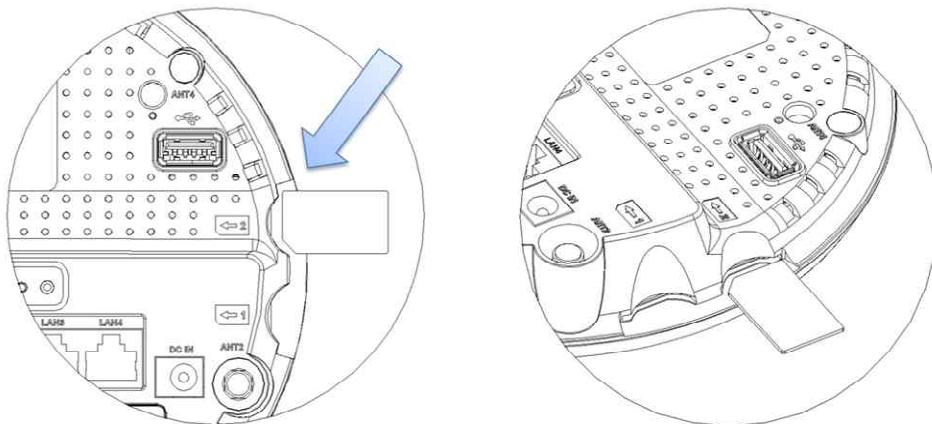

Note

•If you ever need to remove your SIM card from your router, gently press the SIM card inward to release it, and remove from the slot.



Installing the Antennas

To install the antennas, follow these steps.

- ① Align the antennas with the antenna posts on the C773 router as shown below.
- ② Mount the antennas on the antenna posts, and ensuring the connection.
- ③ Swivel the antennas in any direction, in order to better fix the antennas, please check your router placed.

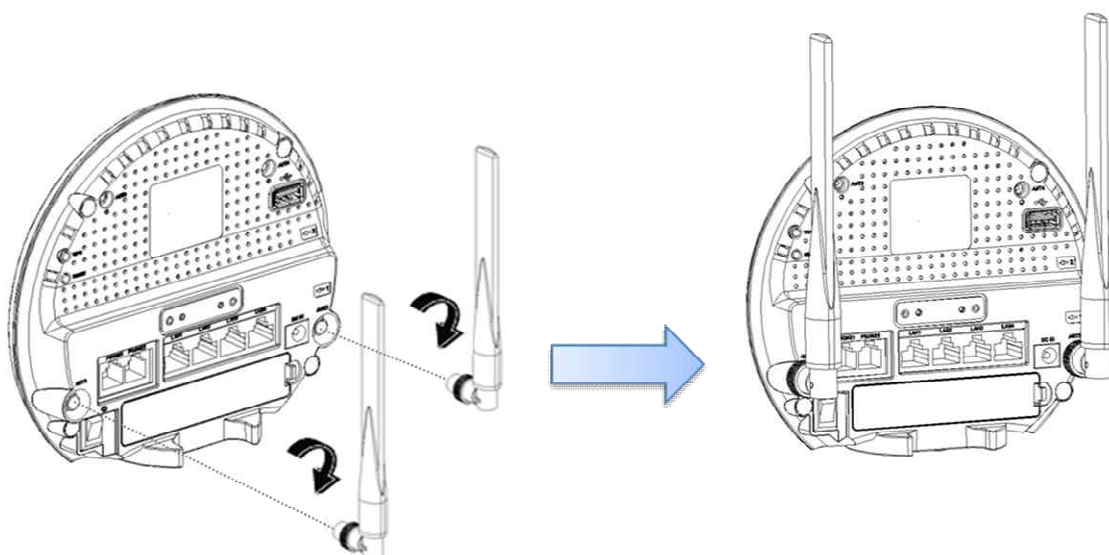

Note

- These two external antennas are required for proper 4G service, and therefore position these antennas on right angle to each other for the best 4G signal reception.

Charging the battery

- ① Open the battery door at the back panel of C773 router.
- ② Insert a new battery which the plus (+) and minus (-) marking match the markings in the battery compartment.
- ③ Close the battery door.



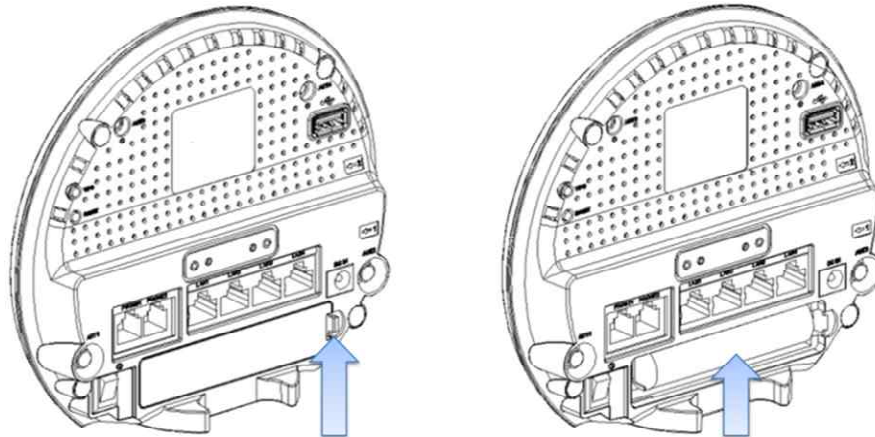

Note

- When the AC adapter is connected then the battery will charge automatically.
- The battery power can supply power for voice calling service in case of power outage or emergency. The Wi-Fi and LAN service will be disabled during battery powered operation.

Battery Tips

Warning!

- Use only Franklin Wireless approved batteries and chargers with your device.
 - Failure to use a Franklin Wireless approved battery and charger may increase the risk that your device will overheat, catch fire, and/or explode resulting in property damage, serious bodily injury, and/or death.
-

Battery life can vary based on the network, signal strength, temperature, features enabled, and accessories you use.

- If you connect your device to your computer using the A/Adapter cable, the battery will charge.
- It normally takes at least 3 hours to fully charge the battery with an A/Adapter.
- New batteries or batteries stored for a long time may take additional time to charge.
- When charging your battery, keep it near or below room temperature.
- Never expose batteries to temperatures below 32°F (0°C) or above 113°F (45°C).
- Never leave the device in an unattended vehicle due to uncontrollable temperature variations.
- It is normal for batteries to gradually weaken and require longer charging times.
- If you notice a change in your battery life, it is may be time to purchase a new battery.



Hooking up your telephone

- ① Plug in your telephone into RJ-11 port 1 or port 2 as shown below.

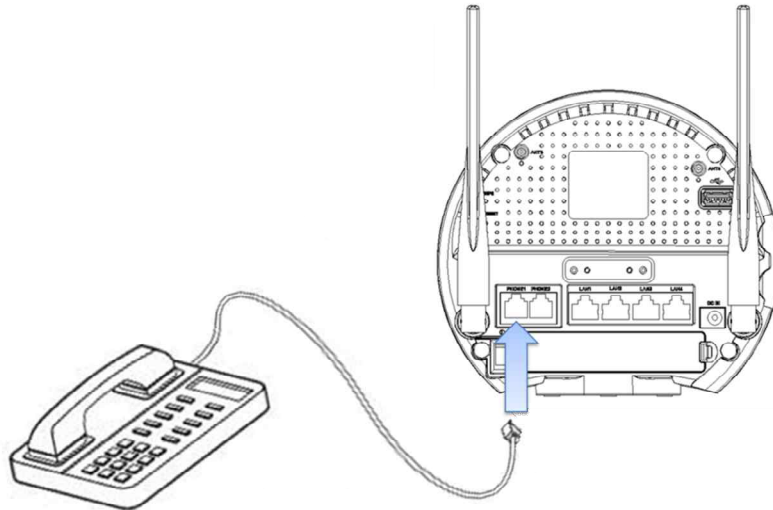

Plug-in the Power Adapter and Turn on the device

- ① Connect the Power Adapter to the C773 router and plug the Power Adapter into an outlet.
- ② Press the Power On/off button.

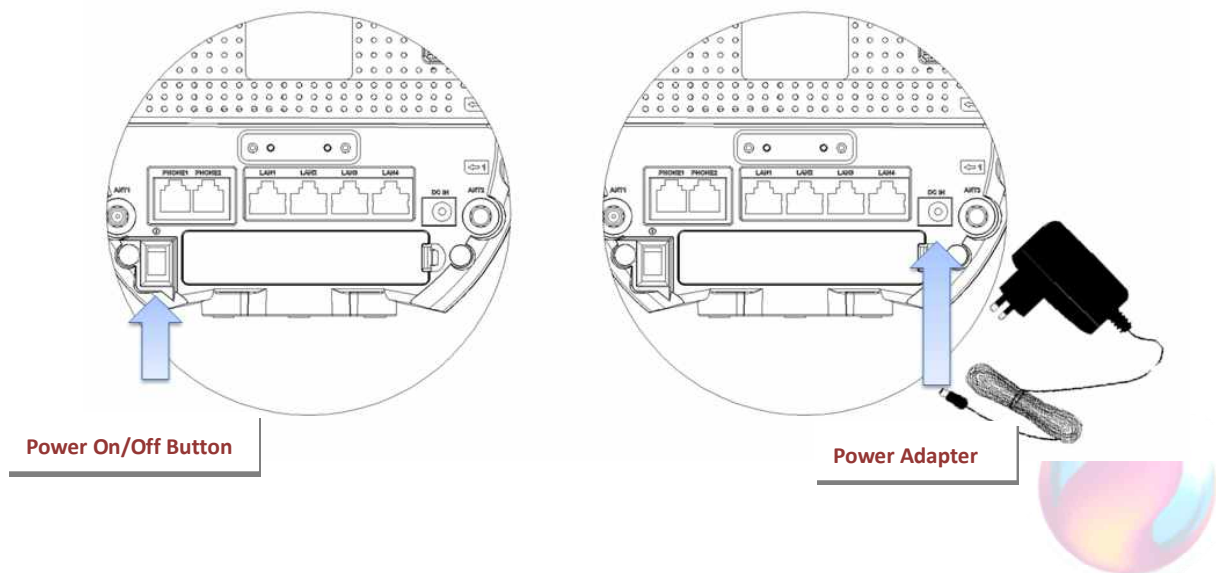

External Antenna for Voice Calling Service and GPS

The C773 router has an integrated internal antenna for the Voice Calling Service and GPS., however if you want to use an external antenna for any reason, you can utilize the external antenna ports (MCX- micro coaxial female antenna not included).

How to Connect External Antenna for Voice Call Service (Note: Antenna not included or required for standard operation)

- ① See **ANT3** label on the upper left side of the back panel of your router.
- ② Check the antenna port which is a MCX type antenna port.
- ③ Plug your extension cable or antenna.

< 1xCDMA Extension Port - Female Type >

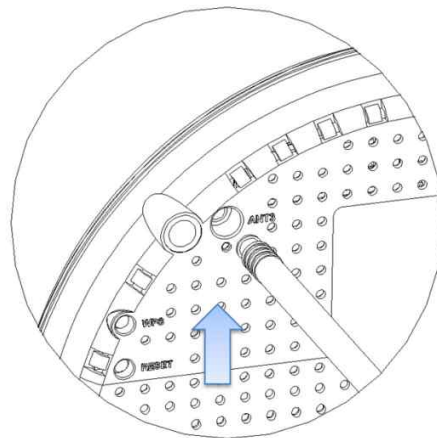

Connect External Antenna for GPS Service (Optional)

- ① See **ANT4** label on the upper right side of the back panel of your router.
- ② Check the antenna port which is a MCX type port.
- ③ Plug your extension cable or antenna.

< GPS Extension Port - Female Type >

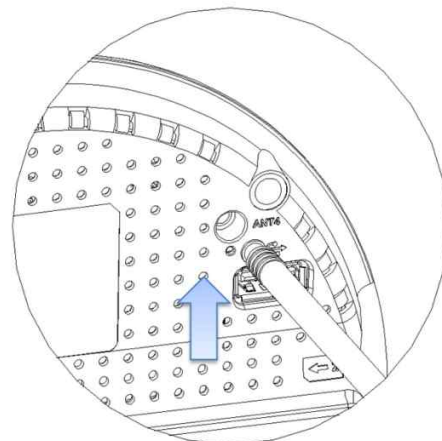

Activating your device

Activating LTE Data Service

- ① After inserting your SIM card, power up the C773 router, and connect the router with your PC (LAN or Wi-Fi).
- ② Open your Web browser and enter <http://192.168.1.1/> into the address window of your browser, Enter your username and password in the Login dialog. (See more detail in Chapter 4)
- ③ Once connected, check the 'USIM State' in the WWAN menu.

A. If your SIM card did not activate properly, you will see the USIM State as 'Inactive' as shown below.

WWAN Device Status
This page displays the WWAN Device connection Info

WWAN Modem status	Values
Manufacturer	N/A
Model	N/A
Firmware Version	N/A
MSISDN	N/A
IMEI	N/A
UICCID	N/A
IMSI	N/A
PRL Version	N/A
USIM State	Inactive
Connection Status	Disconnected
Service Type	No Service
Roaming	No
RSSI	0 dBm

[Help](#)

B. If your SIM card activated correctly, you will see the USIM State as 'Active' as shown below.

WWAN Device Status
This page displays the WWAN Device connection Info

WWAN Modem status	Values
Manufacturer	Franklin wireless
Model	M773
Firmware Version	M773F38.OM.M788
MSISDN	9393580214
IMEI	990000950008427
UICCID	89011200100001675666
IMSI	330120000167566
PRL Version	407
USIM State	Active
Connection Status	Connected
Service Type	LTE
Roaming	No
RSSI	-47 dBm

[Help](#)

Warning

If your SIM card did not come pre-activated or you need to re-activate your SIM card, you may need to:

- A. Go to your network operator's retail store.
- B. Contact your network operator's customer service department.

In case of using damaged SIM cards, locked SIM card or no SIM Card, you will see following Web UI.

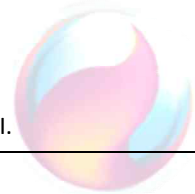

Activating Voice Call Service

- ① Connect your telephone into the C773 router.
- ② Hook off your telephone handset.
- ③ Press the dial button to “*228” in order to dial up the activation system of your network operator.
- ④ When the activation process is done, you should hear a voice message from your network operator system.

Warning

If the activation process did not complete or you were unable to make a Voice Call service please:

- A. Go to your network operator’s retail store.
 - B. Contact your network operator’s customer service department.
-



Connecting to the Router

Please connect your computer to the C773 router if you haven't already.

Wi-Fi connection

- ① Turn on your computer and turn on the C773 router. The router's LTE () LED should be solid green or orange, indicating the device is in service and ready to connect. The C773 router broadcasts its own wireless network.
- ② On your computer, use the Wi-Fi manager (Windows) or the AirPort menu bar icon (Mac OS X) to connect wirelessly to the C773 router's wireless network.
- ③ The steps to connect to a Wi-Fi network may vary depending on your operating system, native Wi-Fi application, or third-party software used. Generally, you click an icon in the Windows notification area where you can select **View Available Wireless Networks**, or click the Airport icon in the menu bar on a Mac. If you are unfamiliar with wireless networking on your computer, consult the computer's help system.
- ④ Select your C773router's network name (**Franklin CPE XXXX Secure**, where **XXXX** are digits unique to your device), click **Connect**, and type in your password. Your network name (SSID), and Wi-Fi/Admin passwords are on the back of your device as well as in the Quick Start Guide.

LAN Connection

- ① Plug in the Ethernet Cable to connect your computer and the C773 router's LAN () LED should be solid blue, indicating the detection for the Ethernet Cable Connection.
- ② The C773 router uses Standard TCP/IP properties for DHCP (Dynamic Host Configuration Protocol) and should connect immediately without any user action. If you need to use a static IP address you will need to change the settings IP settings using advance options (see the next section).

Voice Connection

- ① Plug in the RJ-11 Cable to connect your telephone, The router's Voice () LED should be solid green or orange, indicating the device is in service and ready to use Voice Call Service.



WPS Configuration

Any wireless computer or wireless adapter that connects to the router wirelessly is a client. The client of your computer's system must support a WPS button, and also must have a WPS configuration utility. The WPS method is used to easily add devices to Wireless network using a PIN or a push button, so that the client devices must support WPS capability in order to be configured by this method.

To setup the WPS feature between your C773 router and your client, follow the below steps

- ① Login your CPE router through Web UI. (See more detail in Chapter 4)
- ② Go to '**WLAN Wi-Fi Protected Setup**' item in WPS Settings of Wireless menu.

WLAN WiFi Protected Setup (WPS)
WPS is used to easily add devices to Wireless network using a PIN or a push button. The devices must support WPS capability in order to be configured by this method.

SSID: Franklin_CPE 1136

WPS Configuration

WPS Enable
WPS Enrollee Support
Internal Registrar Support
Proxy Mode Support

Apply Changes

WPS State Configured/Unconfigured

Personal Identification Number (PIN) Method

Please enter the PIN from your wireless device, select the MAC address of the station and push the Connect button.

Select WPS device MAC address for connection via Pin: Any MAC

Configure Authorized MAC list

Enter Client Device Pin:

PIN Settings

Current Router PIN: 12345670

Push Button Configuration (PBC) Method

Click "Start PBC", then start PBC on the device you want to connect to the router within two minutes.

For PBC (Push Button Configuration) method, it will be operated by WPS button on the C733 router.

- ③ Push the 'Start PBC' button or press the 'WPS button' on the router.
 - A. The router will try to communicate with the client (your computer, Laptop, Smartphone and so on) for 2 minutes.
 - B. During the WPS operation, the router's Wi-Fi LED will be blinking with Blue color.
- ④ Go to the client wireless computer, and run a WPS setting utility and click a WPS button in the utility's instruction.
 - A. If the WPS operation is done, the router's Wi-Fi LED will not be blinking and stay in Sold color.
- ⑤ Go back to the router's Web UI, and check the Wi-Fi status whether the client is connected or not.

Note

- Before the WPS activity, we recommend removing the router Wi-Fi's profile stored on your device(PC, Laptop, Smartphone), and the device should be waiting about two minutes after pressing the WPS button, otherwise a mismatch between them will be possible to happen and therefore the router device will be executing to restarting.

- Only supports 1:1 connection between the router and device (laptop, PC, smart phone and so on), The WPS function will be operating as the WPA type's security. If you want to use the WPS function with the WPA2 security, client OS version must be more than windows XP Service Pack 3. And please remove the router Wi-Fi's profile stored into your device.

- If you want to use a WPS PIN(Personal Identification Number), the client device must support a WPS PIN method in a WPS configuration utility, to run the WPS PIN procedure, please see the below steps.
 - 1) Go to the client wireless computer and run the client WPS configuration utility and generate a PIN number.
 - 2) Take notes the client PIN number.
 - 3) In the WLAN Wi-Fi protected setup Web page, there is a PIN inputting method for 'Enter Client Device PIN' item.
 - 4) Enter the client PIN number noted and press the WPS button, and then the device will be trying to communication with the client about 4 minutes.



Device Specification

Feature		Description	Remark
Size (W,D,H)		137mm(H) x 153.8mm(W) x 34.5mm(D) (5.39(H) x 6.06(W) x 1.36(D) (inch)	
Weight		About 283g (9.98 oz)	
Operating Temperature		0°C to 60°C	
Humidity		65 %	
Storage Temperature		-10 °C to 85 °C	
Operating time (Battery)		About 40 minute only for Voice Call Service	
Battery and charging		Li-ion Polymer 1050mAh, 3.7V. Rechargeable	
Power		AC Power Adapter 12V/ 2A	
LED Indicators		Power / LAN [1-4] / Voice / Voice Mail/ Wi-Fi/ LTE	
Wireless WAN (WWAN)		4G LTE(B13), 3G eHRPD (BC0/BC1) Receiver diversity (LTE and 3G Diversity support)	
LAN		Ethernet Port (RJ-45) x 4EA	
Voice Call		2G 1xCdma (BC0/BC1) Telephone Port (RJ-11) x 2EA	No Fax
WLAN		IEEE 802.11 b/g/n (2.4GHz)	
Data Speed	4G LTE	100Mbps downlink / 50Mbps uplink	
	3GeHRPD	3.1Mbps downlink / 1.8Mbps uplink	
	WLAN	11Mbps/ 54Mbps/ 150Mbps (IEEE 801.11 b/g/n)	
	LAN	10BASE-T / 100BASE-T	
WLAN & LAN features		DHCP server, DDNS, VPN Pass-Through, DMZ, Port filtering, Port forwarding, Mac filtering, Network sharing (Samba)	
WLAN Security		Pre-configurable security (WEP/WPA/WPA2PSK)	
USIM (UICC)		Removable UICC Card Support	
Desktop and Wall mount		Supported	
LTE Antenna		LTE Primary & Secondary Antenna	
Voice Service Antenna		Integrated Intenna Extension Antenna Port for Voice Call Service	MCX Connector Type
GPS Antenna		Integrated Intenna Extension Antenna Port for Standalone GPS (Optional)	MCX Connector Type

Chapter 3

Browser Interface and Settings for Wi-Fi and LAN service

Login

Open your Web browser and enter <http://192.168.1.1/> into the address window of your browser. The web interface should display as shown below.

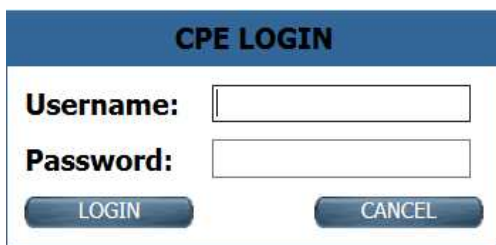

CPE LOGIN

Username:

Password:

Username: **admin**

Password: **admin**

Home Screen Menu

The Home screen is the first screen you see after logging in to the browser interface. It is the main point of entry for all your work in the browser interface. The user menu runs vertically along the left of the browser interface. It shows information of router.



open 4G LTE Home | Logout

FRANKLIN C773

- Quick Setup
- Statistics >
- WWAN >
- LAN >
- Wireless >
- Firewall >
- Content Sharing >
- System >

Platform Version Information	
Software Version	OPM_LR300CG31E1

Default WAN Connection	
Wan Mode	LTE WAN
IP Address	23.18.151.128
Connection Type	Dhcp Client
DNS Server	67.215.111.51
	67.215.111.52

LAN Information	
IP Address	192.168.1.1
DHCP Mode	Server
Connected Clients	1

Ethernet PHY Port Status	
PORT-1	Link Down
PORT-2	Link Down
PORT-3	Link Down
PORT-4	Link Down

WLAN Information	
Radio-1	Up

Quick Setup Menu

Quick Configuration options for Wi-Fi settings including SSID name and security type, and therefore you can modify those configured items quickly.

Quick Configuration of WLAN AP Settings. The same settings need to be done in stations also.

WLAN AP Setup

WLAN Radio Enable	<input checked="" type="checkbox"/>
SSID	<input type="text" value="Franklin_CPE 3009"/>
Security Type	<input type="text" value="WPA_WPA2_Mixed"/>
Password	<input type="password" value="••••••"/>

Statistics Menu

- LAN

The LAN statistics provide statistics (by interface) for the connection(s) only.

LAN Statistics
The LAN Statistics gives the per interface statistics on the LAN side.

Interface	TX				RX			
	Packets	Bytes	Errors	Dropped	Packets	Bytes	Errors	Dropped
eth0	834	189738	0	0	0	0	0	0

Ethernet Ports Statistics

Port	TX		RX	
	Packets	Bytes	Packets	Bytes
0	0	0	0	0
1	0	0	0	0
2	0	0	0	0
3	0	0	0	0

- WAN

The WAN statistics provide statistics (by interface) for the WAN connection(s) only.

WAN Statistics
The WAN Statistics gives the per interface statistics on the WAN side.

Interface	WAN Channel	Connection Type	TX				RX			
			Packets	Bytes	Errors	Dropped	Packets	Bytes	Errors	Dropped
lte0	LTE	Dhcp Client	1225	159330	0	957	1094	172972	0	0

- **WLAN**

The WLAN Statistics provides counters for all WLAN interfaces.

WLAN Statistics.
The WLAN Statistics provides counters for all WLAN interfaces.

AP/VAP name	TX				RX			
	Packets	Bytes	Errors	Dropped	Packets	Bytes	Errors	Dropped
MyAP1	2563	1142703	0	4	3190	462135	0	0

[Help](#)

WWAN Menu

- **WWAN Status**

WWAN Status shows your current network information.

WWAN Status

No	WAN Channel	Connection Type	Status	IP	Netmask	Connection Name	
1	LTE	Dhcp Client	CONNECTED	23.18.76.86	255.255.255.252	WANIP0	<input type="button" value="Release"/> <input type="button" value="Renew"/>

Gateway Information
23.18.76.85

DNS Information

	IP
Primary	67.215.111.51
Secondary	67.215.111.52

[Help](#)

- **WWAN Device status**

WWAN Device status displays the LTE modem information, and also has the Preferred Mode setting and Data Roaming setting items.

WWAN Device Status
This page displays the WWAN Device connection Info

WWAN Modem status	Values
Manufacturer	Franklin wireless
Model	M773
Firmware Version	M773F38.OM.M788
MSISDN	9393580214
IMEI	990000950008427
UICCID	89011200100001675666
IMSI	330120000167566
PRL Version	407
USIM State	Active
Connection Status	Connected
Service Type	LTE
Roaming	No
RSSI	-47 dBm

[Help](#)

WWAN Modem Preferred Mode Setting

Preferred Mode	LTE/CDMA	<input type="button" value="Apply"/>
----------------	----------	--------------------------------------

WWAN Modem Data Roaming Setting

Data Roaming	eHRPD Enabled	<input type="button" value="Apply"/>
--------------	---------------	--------------------------------------

WWAN Modem APN Setting

APN Info	inet.openmobilepr.com	<input type="button" value="Apply"/>
----------	-----------------------	--------------------------------------

- WWAN Modem Status displays the following:
 - Router's manufacturer.
 - Router's model name.
 - Router's firmware version in use.
 - Mobile Station International ISDN Number (MSISDN).
 - International Mobile Equipment Identity (IMEI).
 - Universal Integrated Circuit Card Identity (UICCID).
 - International Mobile Subscriber Identity (IMSI)
 - PRL version in use.
 - USIM State (ex, Active, Inactive)
 - Connection status information (ex, Connected, Disconnected, Dormant)
 - Data Service type (ex, LTE, EVDO Rev.0, EVDO Rev.A, eHRPD, 1xRTT, or No Service)
 - Data Roaming Status (ex, Yes, No)
 - RSSI (Received Signal Strength Indicator, dBm) Level

- WWAN Modem Preferred Mode Setting's item have the following options:
 - LTE/CDMA: the modem will operate and search a network automatically
 - 1xRTT Only : the modem will operate on 1xCDMA network
 - EVDO Only : the modem will operate on EVDO network
 - CDMA + EVDO Only : the modem will operate with 1xCDMA or EVDO network
 - LTE Only : the modem will operate on LTE network

- WWAN Modem Data Roaming Setting item is used to set the roaming conditions between other operators (currently roaming service is only available for EVDO networks and availability depends on your network operator's policy).
 - eHRPD enable: Enabling the roaming service
 - eHRPD disable: Disabling the roaming service

- WWAN Modem APN Setting item is allowed to set your operator's APN (Access Point Name) information (Your default APN value should be '**inet.openmobilepr.com**').



- **DNS**

A Domain Name System server translates hostnames or domain names to IP addresses.

If there is a DNS server that you would rather use, you can specify it in the IP address box below.

Domain Name System (DNS)

A Domain Name System (DNS) server translates hostnames or domain names to IP addresses. Most ISPs provide a DNS server for speed and convenience. Since your Service Provider may connect to the Internet with dynamic IP settings, it is likely that the DNS server IP addresses are also provided dynamically. However, if there is a DNS server that you would rather use, you need to specify the IP address below.

Domain Name Server(DNS) Address . . .

Secondary DNS Address (optional) . . .

- **DDNS**

Dynamic DNS allows you to update your dynamic IP address with one or many dynamic DNS server.

You can use this to allow can access your local FTP or Web service using a DNS-like address.

DDNS Settings

Dynamic DNS allows you to update your dynamic IP address with one or many dynamic DNS services. So anyone can access your FTP or Web service on your computer using DNS-like address.

Enable DDNS Support

WAN Interface

	DDNS Server	Host Name	User Name	Password
<input checked="" type="radio"/>	dhs	<input type="text"/> .dyn.dhs.org	<input type="text"/>	<input type="text"/>
<input type="radio"/>	dyndns	<input type="text"/> .dyndns.org	<input type="text"/>	<input type="text"/>
<input type="radio"/>	dyns	<input type="text"/> .dyns.cx	<input type="text"/>	<input type="text"/>

LAN Menu

- **LAN ARP List**

The ARP list allows you to see which clients are connected to the CPE device via IP address and MAC address.

ARP List

The ARP list allows you to see which clients are connected to the CPE device via IP address and MAC address.

MAC Address	IP Address	HW Type
02:50:f3:00:00:00	23.18.76.85	0x1
9c:4e:36:52:30:bc	192.168.1.2	0x1

- LAN Settings

You can configure LAN settings of the router device such as LAN IP Address and DHCP configuration.

LAN Settings

You can configure LAN settings of CPE device such as LAN IP Address and DHCP configuration.

IP Address: 192.168.1.1
 Subnet Mask: 255.255.255.0
 MAC Address: 00: E0: 92: 00: 11: 00
 Secondary level subnet Range: Enable
 DHCP Mode: Server

DHCP Server

IP Pool Starting Address: 192.168.1.100
 IP Pool Ending Address: 192.168.1.254
 Lease Time: One day
 Local Domain Name: dsign.franklinwireless.com (optional)

IP Address Reservation

[Click Here](#)

Help Apply Cancel

IP reservation Allow static IP address assignment by DHCP server for specified MAC address

IP Reservation

IP reservation Allow static IP address assignment by DHCP server for specified MAC address

HOST NAME	IP ADDRESS	MAC ADDRESS	ENABLE	
unknown	<input type="text"/>	<input type="text"/>	<input type="checkbox"/>	Add

Help Cancel

- UPnP Devices

The UPnP Devices list allows you to see all UPnP devices that are discovered by the CPE.

UPnP Devices List

The UPnP Devices list allows you to see all UPnP devices that are discovered by the CPE.

UPnP Devices	Model Description	UUID
192.168.1.1	985143b7-4eb4-44e2-982f-a172bf876c49	192.168.1.2
4861cbbc-8ad0-44c4-bb6c-fe9e1deb338c	985143b7-4eb4-44e2-982f-a172bf876c49	192.168.1.2
192.168.1.1	985143b7-4eb4-44e2-982f-a172bf876c49	192.168.1.1
985143b7-4eb4-44e2-982f-a172bf876c49	192.168.1.1	985143b7-4eb4-44e2-982f-a172bf876c49
192.168.1.1	985143b7-4eb4-44e2-982f-a172bf876c49	192.168.1.2
4861cbbc-8ad0-44c4-bb6c-fe9e1deb338c	985143b7-4eb4-44e2-982f-a172bf876c49	192.168.1.2

Refresh Help



- **Routing Table List**

The Routing table displays configured routes and interfaces on CPE device.

Routing Table

The Routing table displays configured routes and interfaces on CPE device.

Destination IP	Subnet Mask	Gateway	Metric	Interface
23.18.76.84	255.255.255.252	0.0.0.0	0	lte0
192.168.1.0	255.255.255.0	0.0.0.0	0	br0
239.0.0.0	255.0.0.0	0.0.0.0	0	br0
0.0.0.0	0.0.0.0	23.18.76.85	0	lte0

[Refresh](#)

[Help](#)

- **DHCP Client List**

The DHCP client list allows you to see which clients are connected to the CPE device via IP address and MAC address.

DHCP Client List

The DHCP client list allows you to see which clients are connected to the CPE device via IP address and MAC address.

Host Name	MAC Address	IP Address	Remaining Lease
MSDN-SPECIAL	9c:4e:36:52:30:bc	192.168.1.2	84306

[Refresh](#)

[Help](#)



Wireless Menu

- *Radio Settings*

Configure common WLAN parameters applicable to all active AP in the system.

To show WLAN Advanced Radio Settings page, press the corresponding 'Advanced Radio Settings' button.

WLAN Radio Settings

Configure common WLAN parameters applicable to all active AP/VAP in the system.

Common Settings	
WLAN Radio Enable	<input checked="" type="checkbox"/>
WLAN Radio Status	<input checked="" type="checkbox"/> UP
Frequency Band	2.4GHZ ▾
Country	UNITED STATES ▾
Auto Channel Select Enable	<input checked="" type="checkbox"/>
Channel No.	10 ▾
Operational Mode	802.11BGN ▾
Auto Rate Fallback Enable	<input checked="" type="checkbox"/>
Max. number of WLAN clients per radio	32

802.11n Settings	
Channel Bandwidth	20/40MHz(Auto) ▾
Extension Channel	Above Control Channel ▾
Guard Interval	Long (800ns) ▾
20/40 MHz Co-Existence Enable	<input checked="" type="checkbox"/>

Advanced Radio Settings
Configure Advanced Radio Settings

Advanced Radio Settings

Help Apply Cancel

WLAN Advanced Radio Settings

Configure advanced WLAN parameters applicable to all AP/VAP in the system.

WLAN General Config	
Preamble	Short Preamble ▾
Beacon Interval	100 in ms [20..999]
DTIM Interval	5 in beacons [1..255]
Power Level	100 % ▾
RTS Threshold	2347 in bytes [0..2347]
Static Rate in Mbit/s	AUTO ▾
802.11h Radar Detection	OFF ▾

802.11n Settings	
Length of MPDU aggregation	32767 ▾
STBC	OFF ▾
40 MHz Intolerance	Not Intolerant ▾

WAVE Specific Settings	
Advanced Low Density Parity Check (LDPC)	ON ▾
Beamforming	OFF ▾

Help Apply Cancel



- **Wireless Settings**

This page shows all WLAN AP/Virtual AP in the system. To modify the main parameters of an AP/Virtual AP, press the corresponding 'Modify' button.

WLAN Main Settings
 This page shows all WLAN AP/VAP in the system. To modify the main parameters of an AP/VAP, press the corresponding 'Modify' button. Please note, that the security related settings for AP/VAP are available from the WLAN Security Settings page.

AP Name	SSID	Type	Radio	Security	Encryption	Authentication	Enable	Status	
MyAP1	Franklin_CPE 1136	AP	Radio-1	Basic	None	Open	<input checked="" type="checkbox"/>	UP	Modify

[Refresh](#)

WLAN AP/VAP Configuration Settings
 This page allows to configure a new VAP or to modify an existing VAP. The security related settings for an AP/VAP are available via WLAN Security Settings page.

Enable AP/VAP

SSID

AP Name

Maximum Client Limit

Number of reserved clients

AP Type

Physical Radio

Enable Hidden SSID Mode

Maximum Bit Rate MBit/s

AP Isolation

[Help](#) [Apply](#) [Cancel](#)

- SSID: you can change or input new Network Name (SSID), the router's default SSID is for 'Franklin CPE XXXX', 'XXXX' is your router's MAC address number last four characters.

- **Security Settings**

AP/VAP related security configuration settings.

WLAN Security Settings
 AP/VAP related security configuration settings.

SSID

Security Selection

Beacon Type

Authentication Type

Encryption Type

[Help](#) [Apply](#) [Cancel](#)

- Basic Wi-Fi security setting configured



WLAN Security Settings

AP/VAP related security configuration settings.

SSID	Franklin_CPE 3059
Security Selection	
Beacon Type	WPA-WPA2
Authentication Type	Personal
Encryption Type	TKIP-CCMP
WPA/WPA2 Settings	
Re-Key Interval	3600
Personal Settings	
Passphrase	••••••••
	Display/Hide Passphrase
Help Apply Cancel	

- Wi-Fi security enabled configuration settings, and the CPE router is enabled the Wi-Fi security type to WPA-WPA2 basically.

● WPS Settings

WPS is used to easily add devices to Wireless network using a PIN or a push button, the devices must support WPS capability in order to be configured by this method.

WLAN WiFi Protected Setup (WPS)

WPS is used to easily add devices to Wireless network using a PIN or a push button. The devices must support WPS capability in order to be configured by this method.

SSID	Franklin_CPE 1136
WPS Configuration	
WPS Enable	<input checked="" type="checkbox"/>
WPS Enrollee Support	<input checked="" type="checkbox"/>
Internal Registrar Support	<input checked="" type="checkbox"/>
Proxy Mode Support	<input checked="" type="checkbox"/>
Apply Changes	
WPS State Configured/Unconfigured	<input checked="" type="checkbox"/>
Personal Identification Number (PIN) Method	
Please enter the PIN from your wireless device, select the MAC address of the station and push the Connect button.	
Select WPS device MAC address for connection via Pin	Any MAC
Enter Client Device Pin	
Connect	
PIN Settings	
Current Router PIN	12345670
Generate PIN	
Push Button Configuration (PBC) Method	
Click "Start PBC", then start PBC on the device you want to connect to the router within two minutes.	
Start PBC	
Refresh Help Cancel	



Firewall Menu

- *Firewall Settings*

The CPE device provides extensive firewall protection against a wide array of common hacker attacks.

This is done by restricting connection parameters to limit the risk of intrusion.

Firewall Setting

The CPE device provides extensive firewall protection against a wide array of common hacker attacks. This is done by restricting connection parameters to limit the risk of intrusion.

Enable Disable

Help Apply Cancel

- *ACL*

Access to the device is restricted to IP Addresses listed here.

Access Control - IP Address

Access to the device is restricted to IP Addresses listed here

Enable ACL

No	IP Address
1	
2	
3	
4	
5	
6	
7	
8	
9	
10	
11	
12	
13	
14	
15	
16	

Help Apply Cancel



Content Sharing Menu

This menu describes how to access and configure a USB storage drive attached to your router. The USB port on the router can be used only to connect USB storage devices like flash USB drives. Do not connect computers, USB modems, CD drives, or DVD drives to the router USB port

● *USB Driver Requirements*

The router works with 1.0 and 1.1 (USB Full Speed) and 2.0 (USB High Speed) standards. The approximate USB bus speeds are shown in the following table. Actual bus speeds can vary, depending on the CPU speed, memory, speed of the network, and other variables.

USB Spec	Speed/Sec
USB 1.1	12Mbits
USB 2.0	480Mbits

Note

- The router supports both read and writes attribute for FAT16, FAT32, NTFS, and Linux file systems.
- Some USB external hard drive and flash drive require checking onto your computer if these drives are not accessing, such USB external drive will not work on the router.

● *USB Settings*

In the **USB** item, you can see a list of USB device plugged on the CPE router, basically the router is integrated the Franklin LTE modem, so that you will see the modem information for 'cdc_ether/cdc_ether/cdc_acm' in the USB type , and also you will see the basic mounted file system information to 'usb-storage' in the USB type.

USB Settings
Always ensure that you click on the Unplug button to safely remove respective USB device.

Connected USB Devices				
USB Type	Product Name	Manufacturer	Serial Number	Description
cdc_ether/cdc_ether/cdc_ether/cdc_acm/cdc_acm	Android	Android	0123456789ABCDEF	NA
usb-storage	Memorette	FM-SEMI	NA	Mass Storage Device (Drives will be automounted based on supported filesystems.)

No USB Storage Devices mounted

If you plug your USB memory stick into the CPE router's USB connector, and then you will see your USB storage information mounted as following.



USB Settings

Always ensure that you click on the Unplug button to safely remove respective USB device.

Connected USB Devices				
USB Type	Product Name	Manufacturer	Serial Number	Description
cdc_ether/cdc_ether/cdc_ether/cdc_acm/cdc_acm	Android	Android	0123456789ABCDEF	NA
usb-storage	Memorette	FM-SEMI	NA	Mass Storage Device (Drives will be automounted based on supported filesystems.)

USB DISK (rev:1100) MEMORETT - 4E6F6E650000					
Mount Path	File System	Total Size	Used Space	Free Space	Percentage of Use
/mnt/usb/Disc-A1	FAT	986592	41032	945560	4%

Safe Remove

Please note the Mount Path information for '/mnt/usb', because it will be used the Folder Path name in the File Share item.

● Enabling Sharing(SAMBA) Server

In the **SAMBA Server** item, you can manage for enabling or disabling the sharing (SAMBA) server.

SAMBA Server Settings

Enable SAMBA

SAMBA Server Name

SAMBA Server Description

Work Group

- **Check** the 'Enable SAMBA' field for enabling the sharing server.
- Input a Server Name what you want into the 'SAMBA Server Name' field like '**My Share Server**'.
- Input a Server Name Description what you want into the 'SAMBA Server Description' field.
- Input a Work Group Name what you want into the 'Work Group' item like '**WORKGROUP**'.

Note: If you are using a Windows workgroup rather than a domain, the workgroup name is displayed here. The name works only in an operating system that supports NetBIOS, such as Microsoft Windows.

● Share Management

In the **Share Management** item, you can manage a file sharing information, and for the first time there is no item.

Share Management

Create a Share for file sharing.

Share Name	Folder Path	Users	Access Level	Select
------------	-------------	-------	--------------	--------

In the Add/Modify File share item, you can add or modify your file sharing information.



Add/Modify File share

File Share Name

Folder Path

Access Level

Users

Apply Cancel Help

- Input a sharing name into the 'File Share Name' field like **'MyShare'**.
- Input a folder path string into the 'Folder Path' field to **'/mnt/usb'** which is described on the USB Settings item before.
- Choice the Access Level on your policy for Read Only or Read-Write.
- Select a User which is configured on the User Management item.

After finishing the above procedure, and then you may see the shared information as following

Share Management

Create a Share for file sharing.

Add

Share Name	Folder Path	Users	Access Level	Select
MyShare	/mnt/usb	root	Read-Write	<input checked="" type="radio"/>

Modify Delete Help

Note

- In order to see the mounted folder base on your laptop computer, which is shared by CPE's SAMBA Server, please see the below steps.
 - Using Windows Explorer.
 - Typing the CPE Router's IP Address '**\\192.168.1.1[folder Name like MyShare]**' into Windows Explorer.
 - If you type just for the router IP address without a shared folder name like '**\\192.168.1.1**', the network access time on the Windows Explorer will take a long time in order to find out the shared folder.
 - Using Command Prompt
 - Opening the Command Prompt on your Windows Operating System.
 - Try printing, for example, "**C:\net use m: \\192.168.1.1[folder name like MyShare]**"



System Menu

● Host Name Config

Enter the host name for the CPE device and the domain name you want to configure. Host name can be used in place of IP address.

Host name
Enter the host name for the CPE device and the domain name you want to configure. Host name can be used in place of IP address.

Host Name	<input type="text" value="franklincpe"/>
Domain Name	<input type="text" value="franklinwireless.com"/>

[Help](#) [Apply](#) [Cancel](#)

● System Time

Connecting to a Simple Network Time Protocol (SNTP) server allows the CPE device to synchronize the system clock to the global Internet.

System Time
Connecting to a Simple Network Time Protocol (SNTP) server allows the CPE device to synchronize the system clock to the global Internet.

Current System Time	<input type="text" value="Tue Jun 25 10:56:31 2013"/>
Set Time Zone	<input type="text" value="(GMT+05:30) Calcutta, Chennai, Mumbai, New Delhi, Sri Jayawardenepura"/>
SNTP Client	<input checked="" type="checkbox"/> Enable
Primary SNTP Server	<input type="text" value="0.asia.pool.ntp.org"/>
Secondary SNTP Server	<input type="text" value="1.asia.pool.ntp.org"/> (Optional)

[Help](#) [Apply](#) [Cancel](#)

● Administrator Settings

Set a password to restrict management access to CPE device.

Administrator Settings
Set a password to restrict management access to CPE device.

Disable Administrator Password	<input type="checkbox"/>
Select user	<input type="text" value="admin"/>
Current Password	<input type="password"/>
Password	<input type="password"/> (password can be 3-16 Characters without white space)
Re-type password	<input type="password"/>
Enable account	<input checked="" type="checkbox"/>
Remote Web access enable	<input checked="" type="checkbox"/>

[Help](#) [Apply](#) [Cancel](#)

● Web Settings

Set Auto logout Time limit for CPE device.

Web Timeout Settings
Set Autologouttime(in seconds) limit for CPE device.

Autologout Duration	<input type="text" value="1800"/>
---------------------	-----------------------------------

[Apply](#) [Cancel](#)



● **Software/Firmware Upgrade**

Specify the path and name of the image file to be upgraded and click the APPLY button below.

You will be prompted to confirm the upgrade. After the upgrade process, the system will reboot automatically.



● **System Log**

This page allows to manage the logging options in CPE device.

For viewing system log, the events corresponding to the priority level equal to or higher than the selected level will be displayed here.

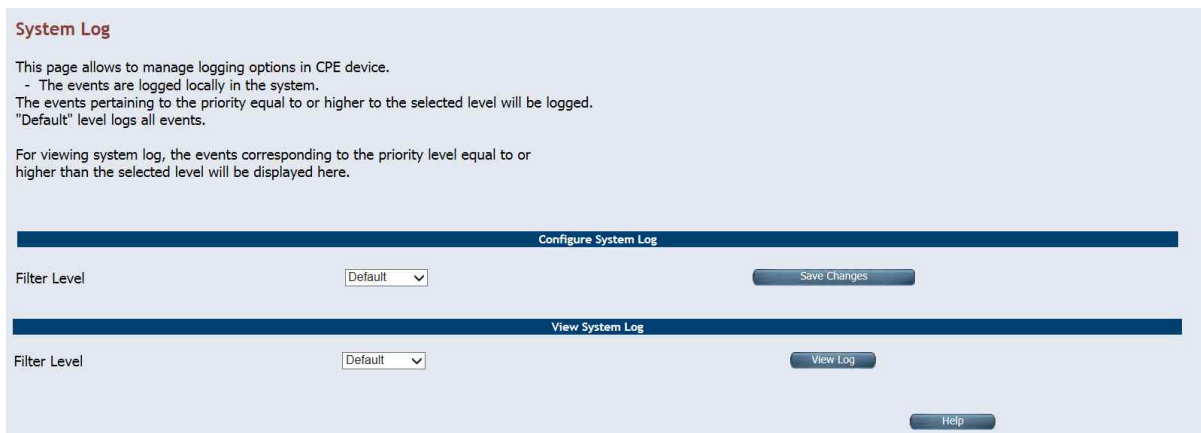

● **Reset**

In the event that the CPE device stops responding correctly or in some way stops functioning, you can perform a reset by clicking on the 'Reset' button below.

By pressing 'Factory Reset' all user configurations are replaced with factory default configuration settings.



User Menu

- *Voice User Menu Instructions*

To alter voice options, pick up the handset and enter the appropriate code as listed in the table below. For detailed information on the voice options listed in the table, please refer to the detailed description in the following section(s).

	Menu Tree	Entry Code
1. Ring / Sound	1. Ring Type	11
	2. Volume Level	12
	3. DTMF Tone Length (Long or Short)	13
	4. 1Min Alert	14
	5. Svc Alert	15
2.Tools	1. Caller ID	21
	2. Dial Tone	22
3. Time	1. Auto Send Time	31
	2. Flash Time	32
	3. On Hook Time	33
4. Activating	1. New Lock Code	41
	2. Outgoing Restrict	42
	3. Reset Phone	43
	4. Voice Privacy	44

For example, an entry code: '##XX' (where 'XX' is a two digit code in the table above).

Examples) ##11 → to go to Ring Menu (option 1) and then select the Ring Type (option 1 in sub menu)

##12 → to go to Ring Menu (option 1) and then select the Volume Level (option 2 in sub menu)

Note

- Users will be able to hear a tone after every menu selection. (ex : confirmation tone, fail tone, etc)
-

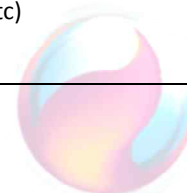

Ring / Sound Menu (Option 1)

Ring Type	(Option ##11)
<ul style="list-style-type: none">- There are 9 ring types.- In this menu, you can select '1~9'. After selecting, press '*' to store the ring type.- If you choose '0' key instead of '*', the menu will be canceled.- If you press '#' to exit. <p>Ex) ##11 → 0 or # → Just cancel. It will make a terminal to idle status.</p> <p>##11 → 1 ~ 9 (assign ring tone) → * : Index 1's ring tone will be selected.</p>	

Volume Type	(Option ##12)
<ul style="list-style-type: none">- In the volume menu, you can adjust the ring volume.- Press '1' to increase volume, and press '2' to decrease volume.- Once the preferred volume level is selected, press '*' to save or press '#' to cancel and exit.	

DTMF	(Option ##13)
<ul style="list-style-type: none">- In the DTMF menu, you can select DTMF tone length.- Press '*' to increase the tone length, press '#' to reduce the tone length (DTMF).	

1 Min Alert	(Option ##14)
<ul style="list-style-type: none">- In the 1 Min Alert menu, you can set/remove the 1 Min alert notification.- If you press '*' to set this option, the phone will notify alert to you 1 min later in conversation.- If you want to remove this option, press '#'.	

Service Alert	(Option ##15)
<ul style="list-style-type: none">- In the Service Alert menu you can set/remove the Service alert notification.- If you press '*' to set this option, the phone will notify alert to you in and out Service Area.- If you want to remove this option, press '#'.	

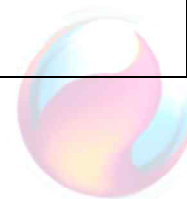

Tools Menu (Option 2)

Caller ID	(Option ##21)
<p>- In the Caller ID menu, you can select a CID format for your phone type.</p> <p>- There are 3 types of caller ID.</p> <p>- After selecting a CID type, press '*' to save.</p> <p>- If you don't want to set a caller ID, press '#' to cancel.</p> <p>Caller ID options:</p> <ol style="list-style-type: none">1. BELLCORE2. V.233. DTMF4. None CID (same as '#' key)	

Dial Tone	(Option ##22)
<p>- In the Dial tone menu, you can select a dial tone for your country.</p> <p>- There are 6 types of dial tones</p> <p>- Press '*' to set. Press '#' to cancel.</p> <p>Dial tone types:</p> <ol style="list-style-type: none">0. USA1. India2. Latin America3. East Europe4. China / Syria5. Nicaragua6. South Africa <p>Ex) ##22 + 6 + * : to set the dial tone to the South African dial tone.</p>	



Time Menu (Option 3)

Auto send time					(Option ##31)				
<ul style="list-style-type: none"> - In the Auto send time menu, you can select an auto send time. - There are 10 options. (1sec~10sec; see chart below) - After selecting a time, press '*' to save. - If you press '#', the saved time will be cancelled and set to the default time of 3 seconds. 									
Time table:									
1	2	3	4	5	6	7	8	9	0
1sec	2sec	3sec	4sec	5sec	6sec	7sec	8sec	9sec	10sec

Flash time					(Option ##32)				
<ul style="list-style-type: none"> - In the Flash time menu, you can change flash time from 50 to 999 ms (default : 100 ms). - You can not set a flash time bigger than on-hook time. If you need to do so, please first adjust on-hook time prior to adjusting the flash time (see on hook options below). - Press '*' to set. Or press '#' to cancel. 									
<p>*NOTE: If the entered flash time or on hook time is out of range, it will be ignored.</p>									
<p>Ex) ##32 + 300 + * : to set the flash time to 300 ms</p>									

On Hook time					(Option ##33)				
<ul style="list-style-type: none"> - In the On Hook Time menu, you can change the on hook time from 101 to 1000ms (default : 1000 ms). - If entered time is out of ranges, it will be ignored - You cannot set smaller on hook value than the flash time (see flash time above). If you want to do so, please adjust a flash time first, and then, set the on-hook time - Press '*' to set, Or press '#' to release. 									
<p>*NOTE: If the entered on hook time or flash time is out of range, it will be ignored.</p>									
<p>Ex)##33 + 500 + * : to set the on hook time to 500 ms</p>									

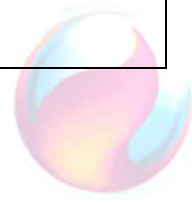

Setting Menu (Option 4)

New Code	(Option ##41)
<p>- This menu will allow you to change a lock code value (the default value is '0000').</p> <p>- Enter ##41, you should hear a confirmation tone.</p> <p>- Enter the current lock code to get a permission to change a lock code.</p> <p>- If the entered current lock code is right, a confirmation tone will be heard.</p> <p>- After confirmation, you enter new lock code. The processes of an entering new lock code have two steps:</p> <ol style="list-style-type: none"> 1) First, you should enter a new lock code and press '*' key. 2) Enter the lock code again for double verification and press '*'. <p>- If first code and second code was matched, a confirmation tone will be heard. Otherwise, the codes are different, you will need to restart the process again.</p> <p>- Press '#' to cancel.</p> <p>Ex) Suppose that the current lock code is '7777', and user wants to change it to '8888'.</p> <p>##41 → confirmation tone → 7777 → confirmation tone → 8888 → Press * → 8888 → Press * → confirmation tone</p>	

Restrict outgoing	(Option ##42)
<p>- You can restrict outgoing calls using this option.</p> <p>- You can set a restriction by pressing*.</p> <p>- Press '#' to cancel.</p>	

Reset phone	(Option ##43)
<p>- You can reset this terminal to make a default factory value.</p> <p>- You can reset a terminal by pressing '*'.</p> <p>- Press '#' to exit the reset menu.</p>	

Voice privacy	(Option ##44)
<p>- You can set the option of Voice privacy to protect your call from being tapping (this feature must be supported by the wireless operator to work).</p> <p>- You can change the option by doing follows.</p> <ul style="list-style-type: none"> - Press '*' for changing a current value to 'Standard' option - Press '#' for changing a current value to 'Enhanced' option. <p>Ex) Suppose a current lock code '7777'</p>	

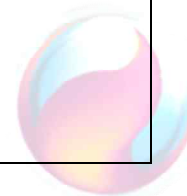

##44 → semi-confirmation tone → 7777 → semi-confirmation tone → Press '#' : Enhanced
##44 → semi-confirmation tone → 7777 → semi-confirmation tone → Press '*' : Standard



Q: What networks does the router operate on?

A: The router operates using your carriers 3G and 4G wireless networks for data service and 2G wireless network for voice service.

Q: What are the air holes on the back side of the router?

A: The air holes are designed to reduce the heat generated by the device itself while it used. Keep the device away from open flames, dusty conditions, and keep it dry for optimal performance.

Q: What kind of security is available with the router?

A: The router supports advanced Wi-Fi security protocol through standard methods such as Wi-Fi Protected Access (WPA & WPA2) and the older Wired Equivalent Privacy (WEP).
Advanced settings are available in the Web based user interface.

Q: What if the user forgets the router password?

A: The router can be reset to the default factory password by the Reset button on the device's back side, depress the small button using a paper clip or pen and hold for 5 second. The power LED will turn off-and-on twice to indicate reset is successful. The unit will power up with the factory default configuration.

Q: What might the owner of the router need to be aware of before sharing with multiple devices?

A: With multiple devices or used as a temporary hotspot:

- If there are several heavy data users on at the same time, you may notice a degradation in performance
- We are strongly recommended that users are not allowed to access more than 10 devices to the router in order to keep the optimal user performance.
- Be aware these users are contributing to your data usage. You may want to check your account online to see how much of a difference it is making and how close you are to any usage caps that may apply under your Franklin wireless network connection plan.

Q: What the battery used for?

A: The router is normally powered by the external AC power, however if AC power is has failed like in the case of an emergency, the battery power will provide Voice Calling only (No internet) service..

- The battery will have on average 3 hours of active use time.

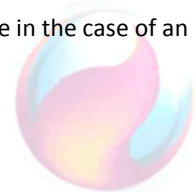

Q: Does the router support fax and/or text messaging?

A: Fax and text message service are not supported.

Q: Can the router be used for memory storage?

A: The router supports external memory using the external USB connector, so you can plug your USB memory stick into the router and use the file sharing method described in the router's Web UI.

Q: How long does a user need to charge the battery before they begin using?

A: The battery must be fully charged before using the router for the first time. We recommend a minimum of 2 hours charging time before first use. After the initial use and set-up, you should use the battery with the AC power.

Q: Does the router require software installation?



A: No, the router uses any web browser (via a URL) that allows the user to configure the device without any installation.

Q: What does the user of the router need to begin to do configuration and activation?

A: See 'Install the 4G LTE SIM Card' section of this manual for activation instructions.

Q: What if the router cannot access the internet even though the unit has been activated?

A: Please verify the below steps first.

- a. Make sure the SSID is correct.
- b. If you use Security Mode, Make sure you use the correct Password.
In case you forget password, try to press the Reset button about 5 seconds.
- c. Make sure the color of LTE LED () is Green or Orange.
If the LTE LED is Red or off, try to reboot and make sure the color of LTE LED is Green or Orange.
If the LTE LED is Red or Off after rebooting, try to Factory Reset.
- d. Make sure the color of Wi-Fi () LED is Blue.
If the Wi-Fi LED is off, try to reboot and make sure the color of Wi-Fi LED is Blue.
If the Wi-Fi LED is off after rebooting, try to Factory Reset.
- e. Maximum 10 devices can share Wi-Fi. Make sure that 10 devices are already connected.
- f. Check the signal strength of Wi-Fi. If you are too far from the router, the connection can be limited.

Q: When will a user of the router need to access the browser interface?

A: The router browser interface will only need to be accessed or used when configuring your device for the first time or changing the security settings or establishing more advanced settings.



Q: Why does the router gets warm?

A: The router has two radios inside: the 3G radio and the 4G radio. In fringe areas of low 3G or 4G coverage, the transmit power will be at the max and therefore generate more heat. The device has been environmentally tested and approved by the FCC.

Q: Why dose not available to access the internet?

A: Please verify the below steps first.

- a. Make sure using the SIM card from Open-Mobile.
- b. Make sure the SIM card is inserted correctly.
- c. Check the SIM card is PIN Locked.

After connecting Wi-Fi, connect Web UI and check the warning of SIM card (see the 'Install the 4G LTE SIM Card', page 7).

- d. Make sure the LTE LED () color is Red or No light.
- e. Check the state of Internet connection is "connected" in Web UI.
- f. Check the Preferred mode in Diagnostics in WEB UI is "Auto".
- g. If the region does not support LTE network, please check what the Data Roaming is "1xEVDO only".
- h. In case DNS IP address of Internet connection in Web UI is differ from Primary DNS IP address in DNS set up, save the DNS IP address in Internet connection on to Primary DNS in DNS Setup and reboot the router.

Q: Why device (Laptop, PC, Smartphone and so on) does not able to connect the router?

A: Please verify the below steps first, if you make a Wi-Fi profile manually and used the Wi-Fi security option to WPA/WPA2 mixed-PSK.

- a. In case the Security type to WPA-PSK, the Encryption type should be saved to TKIP.
- b. In case the Security type to WPA2-PSK, the Encryption type should be saved to AES.

Q: Why dose not available to access the voice service?

A: Please verify the below steps first.

- a. Make sure the Voice LED () color is Red or No light.
- b. Make sure the device is activated or not. (See the 'Activate your device', page 10)

Q: Why the voice call is not working even the Voice LED color is Orange or Green?

A: Please verify the RJ-11 cable between the router and your telephone.

Q: There are two RJ-11 ports in the router's back side, dose the voice call service possible separately?

A: The voice service is not available the separated voice call, but during one conversation, two users could be able to hear and talk simultaneously with two telephones.

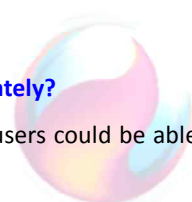

Q: Unable to receive incoming voice call?

A: Please verify your telephone is on hook (hung up) state, if the telephone is off hook state, you may not hear any ring tone when an incoming call is occurred.

Q: if a noise is occurred in your telephone?

A: Please firstly check your telephone and not to hold the curly cord of the receiver when using the terminal (voice call) for it could cause noises

Part 15.105 statement

This equipment has been tested and found to comply with the limits for a class B digital device, pursuant to Part 15 of the FCC Rules.

These limits are designed to provide reasonable protection against harmful interference in a residential installation. This equipment generates uses and can radiate radio frequency energy and, if not installed and used in accordance with the instructions, may cause harmful interference to radio communications. However, there is no guarantee that interference will not occur in a particular installation. If this equipment does cause harmful interference to radio or television reception, which can be determined by turning the equipment off and on, the user is encouraged to try to correct the interference by one or more of the following measures:

- Reorient or relocate the receiving antenna,
- Increase the separation between the equipment and receiver,
- Connect the equipment into an outlet on a circuit different from that to which the receiver is connected,
- Consult the dealer or an experienced radio/TV technician for help.

Part 15.21 statement

" Change or Modifications that are not expressly approved by the manufacturer could void the user's authority to operate the equipment. "



This device complies with Part 15 of FCC Rules. Operation is subject to the following two conditions:

- (1) This device may not cause harmful interference, and
- (2) This device must accept any interference received, including interference that may cause undesired operation.

FCC RF Radiation Exposure Statement:

This equipment complies with FCC radiation exposure limits set forth for an uncontrolled environment. This equipment should be installed and operated with minimum distance 20 cm between the radiator & your body.





- **802.11 (b, g, n)** — A set of WLAN communication standards in the 2.4, 3.6 and 5 GHz frequency bands.
- **Access Point (AP)** — A device that allows wireless communication devices to connect to a wireless network using a standard such as WLAN.
- **DHCP** — Dynamic Host Configuration Protocol. A network application protocol used to obtain configuration information for an Internet Protocol network.
- **DHCP Server** — A server that uses DHCP to obtain configuration information for operation in an Internet Protocol network.
- **DNS** — Domain Name System. A system for converting host names and domain names into IP addresses on the Internet or on local networks that use the TCP/IP protocol.
- **Firmware** — A program that internally controls an electronic device.
- **FTP** — File Transfer Protocol. A network protocol for exchanging files over a TCP network.
- **Gateway** — A network point that acts as an entrance to another network that uses a different protocol.
- **Host Name** — The unique name by which a network-attached device is known on a network.
- **Hotspot** — A WLAN access point or area for connecting to the Internet.
- **HTTP** — Hypertext Transfer Protocol. An application-level protocol for accessing the World Wide Web over the Internet.
- **IP address** — Internet Protocol address. The address of a device attached to an IP network (TCP/IP network).
- **LAN** — Local Area Network. A type of network that lets a group of computers, all in close proximity (such as inside an office building), communicate with one another.
- **MAC Address** — A number that uniquely identifies a given network adapter on a LAN. MAC addresses are 12-digit hexadecimal numbers.
- **MIN** — Mobile Identification Number. It refers to the 10-digit unique number that a wireless operator uses to identify the mobile phone. A MIN is a number that uniquely identifies a mobile working under TIA standards for Cellular and PCS technologies.
- **MSID** — Mobile Station ID. A number provisioned by a service provider to a mobile phone that identifies that phone to the network.
- **MSL** — Master Subsidy Lock. A numeric code for accessing certain phone settings.
- **NAI** — Network Access Identifier. A standard way of identifying users who request access to a network.
- **Network Mask** — A number that allows IP networks to be subdivided for security and performance.
- **NNTP** — Network News Transfer Protocol. An Internet application protocol for reading and posting Usenet (newsgroup) articles.
- **POP** — Post Office Protocol. An Internet protocol for retrieving email from a remote server over a TCP/IP connection.

- **Port** — A virtual data connection used by programs to exchange data.
- **Port Forwarding** — A process that allows remote devices to connect to a specific computer within a private LAN.
- **Port Number** — A number assigned to a user session and server application in an IP network.
- **Protocol** — A standard that enables connection, communication, and data transfer between computing endpoints.
- **PPTP** — Point-to-point Tunnelling Protocol. A method for implementing virtual private networks that does not provide confidentiality or encryption.
- **PRL** — Preferred Roaming List. A list that your wireless phone or device uses to determine which networks to connect with when you are roaming.
- **RFB** — Remote Frame Buffer. A protocol for remote access to graphical user interfaces.
- **Router** — A device that connects two networks.
- **RTP** — Real-time Transport Protocol. A packet format for streaming multimedia over the Internet.
- **SMTP** — Simple Mail Transfer Protocol. An Internet standard for email transmission across IP networks.
- **SSID** — Service Set Identifier. The name assigned to a WLAN network.
- **TCP** — Transmission Control Protocol. A core protocol for transmitting and receiving information over the Internet.
- **TCP/IP** — Transmission Control Protocol/Internet Protocol. A communications protocol developed under contract from the U.S. Department of Defence to interconnect dissimilar systems.
- **Telnet** — Telecommunication Network. A network protocol used on the Internet or on local area networks.
- **TFTP** — Trivial File Transfer Protocol. A file transfer protocol with a subset of FTP functionality.
- **UDP** — User Datagram Protocol. A simple transport protocol used to transfer information on the Internet.
- **VNC** — Virtual Network Computing. A graphical desktop sharing system that uses the RFB protocol to remotely control another computer.
- **VPN** — Virtual Private Network. A secure private network that runs over the public Internet.
- **VPN Pass-through** — A feature that allows a client to establish a tunnel only with a specific VPN server.
- **WAN** — Wide Area Network. A public network that extends beyond architectural, geographical, or political boundaries (unlike a LAN, which is usually a private network located within a room, building, or other limited area).
- **WEP** — Wired Equivalent Privacy. An IEEE standard security protocol for 802.11 networks. Superseded by WPA and WPA2.
- **WLAN** — Wireless Fidelity. Any system that uses the 802.11 standard developed and released in 1997 by the IEEE.
- **WLAN Client** — A wireless device that connects to the Internet via WLAN.
- **WLAN** — WLAN LAN. A typically low-power network that transmits a wireless signal over a span of a few hundred feet and usually only to stationary devices.
- **WPA/WPA2** — WLAN Protected Access. A security protocol for wireless 802.11 networks from the WLAN Alliance.
- **WWAN** — Wireless Wide Area Network. Wireless connectivity to the Internet achieved using cellular tower technology. This service is provided through cellular providers. WWAN connectivity allows a user with a laptop and a WWAN device to surf the Internet, check email, or connect to a virtual private network (VPN) from anywhere within the regional boundaries of the cellular service.