

PREMIUM ENTERPRISE TABLET

ST100

USER
Manual



BLUEBIRD



This user manual is protected by copyright.

The radio equipment can't be used for life saving services because there is possibility to have radio interference and failure. This product's partial functions might have problems from the environment, user program, and other machines. This product's program is legally protected. Illegal copying, transmitting, or erasing of the program is prohibited. This user manual has been created by the Bluebird Inc. We have done our best not to create typos, editing errors, and leaving out any information.

Please understand if there are any inconveniences.



Registered Trademark

BLUEBIRD is an emerging global brand, striving to lead the market in performance and mobility. Their products represent reliability, innovation, and innovative technology. Pidion is a registered trademark from the global brand of Bluebird Inc. and is copyright protected.

User's guidance

Device type	User's guidance
Class B Device (Household Information & Communication)	This device has qualified the electromagnetic wave suitable registration and can be used as a household device at a resi-dential area as well as any other areas.
Type registration	This wireless device may cause propagation interference, and so, it cannot be used for life-saving services.

*Please read warnings and cautious before use.



1 Safety Precautions	
1.1 Symbols	01
1.2 Device	01
1.3 Environment	01
2 Product Overview	
2.1 Package Components	02
2.2 Cradle Set (Optional).....	02
2.3 Device Front.....	03
2.4 Device Back.....	04
2.5 Cradle Front (Optional).....	05
2.6 Cradle Bottom (Optional).....	05
3 Getting Started	
3.1 Inserting a USIM Card	06
3.2 Charging the Device	06
3.3 Turning On the Device	07
3.4 Using Touch Gestures.....	08
3.5 Starting the Device for the First Time (Windows)	09
4 Windows 8.1 Tutorials	
4.1 Start Screen	10
4.2 Desktop.....	10
4.3 Charms Menu	11
4.4 Switching between the Start screen and desktop	12
4.5 Apps Screen	12
4.6 Switching Between Apps.....	13
4.7 Viewing Two Apps at Once	14
4.8 Closing Active Apps.....	15
4.9 Turning Off the Device	15
5 Connecting to Networks (Windows)	
5.1 Connecting to a Wi-Fi Network	16
5.2 Connecting to a Mobile Network.....	16
5.3 Sharing a Mobile Connection	17
5.4 Disconnecting from a Network	17
6 Connecting to Networks (Android)	
6.1 Connecting to a Wi-Fi Network	18
6.2 Connecting to a Mobile Network.....	18
6.3 Sharing a Mobile Connection	18



7 Connecting to External Devices

7.1 Connecting to a Bluetooth Device (Windows)	19
7.2 Connecting to External Devices (Android)	19
7.3 Connecting to USB Devices	20

8 Customizing the Device (Windows)

8.1 Configuring the Start Screen	21
8.2 Changing Your Account Picture	24
8.3 Personalizing the Lock Screen	24
8.4 Setting the Date and Time	25
8.5 Booting to the Desktop	25
8.6 Assigning Function Buttons	25
8.7 Using Quick Settings	26

9 Customizing the Device (Android)

9.1 Customizing Your Home Screen	28
9.2 Using Your Device with Ease	28

10 Using the Card Slots

10.1 Inserting a USIM card	30
10.2 Removing a USIM Card	30
10.3 Inserting a MicroSD card	30
10.4 Removing a MicroSD Card	31
10.5 Accessing Data on MicroSD Cards	31

11 Using the Camera (Windows)

11.1 Installing the Camera App	32
11.2 Opening the Camera App	32
11.3 Taking Pictures	33
11.4 Recording Video	33
11.5 Viewing Photos	34
11.6 Viewing Videos	34

12 Using the Camera (Android)

12.1 Taking Photos	35
12.2 Recording Videos	35

13 Maintenance and Troubleshooting

13.1 Cleaning the Touchscreen	36
13.2 Extending the Battery Life	36
13.3 Troubleshooting	37
13.4 Updating Windows	38
13.5 Backing Up Windows	39
13.6 Recovering Windows	40

Contents



14 Help and Support

14.1 Preparing for Service	41
14.2 Bluebird Customer Service	41
14.3 Conditions for After-sales Service	42
14.4 Charged Service	42

Appendix A Specifications

Appendix B Accessories

Appendix C Safety and Regulatory Compliance



Appendix D Warranty Information

1 Safety Precautions



1.1 Symbols

This manual uses the following symbols to indicate hazards and additional information.

Symbol	Name	Description
	Caution	Indicates a potential hazard that could result in a minor injury or damage to the device.
	Note	Indicates additional information that can help you get the most out of the device.

1.2 Device

- Do not submerge the device in water or expose it to damp conditions. Doing so may damage the device and void the warranty.
 There is a label in the device that changes color when wet. You cannot receive warranty service if this label has changed color.
- Do not press the power button when the device is wet. Doing so may result in an electric shock.
- Do not touch the power adapter or cord with wet hands. Doing so may result in an electric shock.
- Do not attempt to repair, remodel, or disassemble the device. Doing so voids the warranty on the device.
- Do not attempt to dry the device using a heater, microwave, or other tool. Doing so may cause the device to explode or malfunction.
- Do not paint the device. Doing so may damage the screen or the exterior of the device.
- Do not expose the device to severe impacts or vibrations. Doing so may damage the device.
- Do not use this device around products that sustain life. Doing so may result in failure of these products due to electromagnetic interference.

1.3 Environment

- Do not use the device while driving or operating heavy machinery. Doing so may result in death or serious injury.
- Do not use the device in dusty locations. Doing so may damage the device.
- Do not use the device in hot locations. Doing so may damage the device.
- Do not use the device in moist locations. Doing so may damage the device and void the warranty.
- Do not use the device in locations with combustible goods. Doing so may result in an explosion.

2 Product Overview



This chapter explains the components included with the tablet package system and provides an overview of the tablet.

2.1 Package Components

The device includes the following components. If any of these components are missing, please contact the retailer who sold you the device.

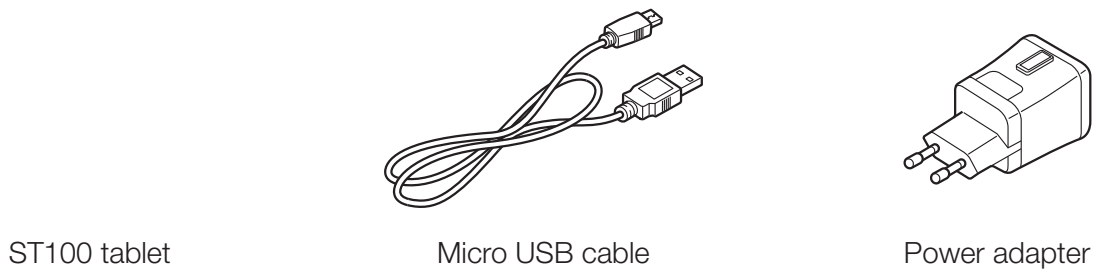

 The images in this manual may not reflect the color and shape of the actual device. These illustrations are intended for descriptive purposes only.

2.2 Cradle Set (Optional)

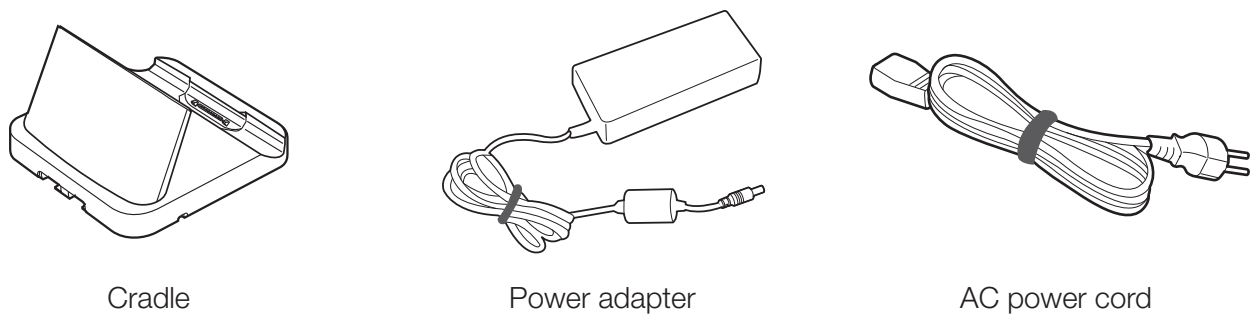



2.3 Device Front

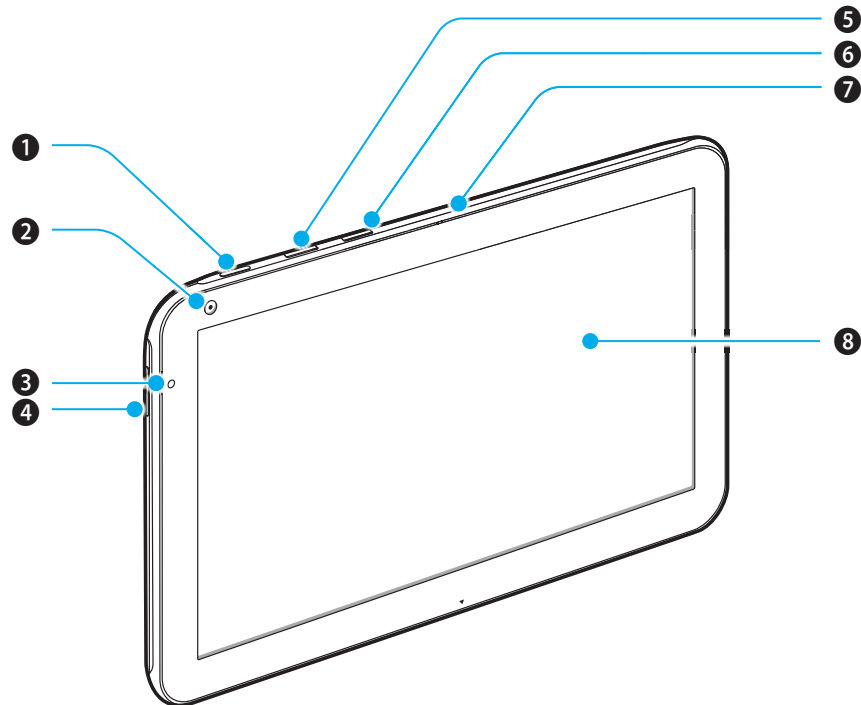

No.	Name	Description
1	Power button	Turns on the device. For more information, see <i>3.3 Turning On the Device on page 07</i> .
2	Front camera	Captures pictures and video (2.0 megapixels).
3	Battery LED	Indicates the status of the battery. <ul style="list-style-type: none"> ⚠ The battery LED turns red when the battery is charging. • The battery LED turns white when the battery is fully charged. • The battery LED blinks red and white alternately at 1 second intervals when the battery has a problem, such as it being too hot or too cold.
4	Volume button	Adjusts the device volume.
5	SIM slot	Accepts an USIM card.
6	Memory slot	Accepts a microSD card.
7	Microphone	Captures sound for video conferencing, voice recording, and speech recognition.
8	Screen	Displays programs and acts as a multi-touch interface. <ul style="list-style-type: none"> ⚠ The default resolution is 1280 × 800.



2.4 Device Back

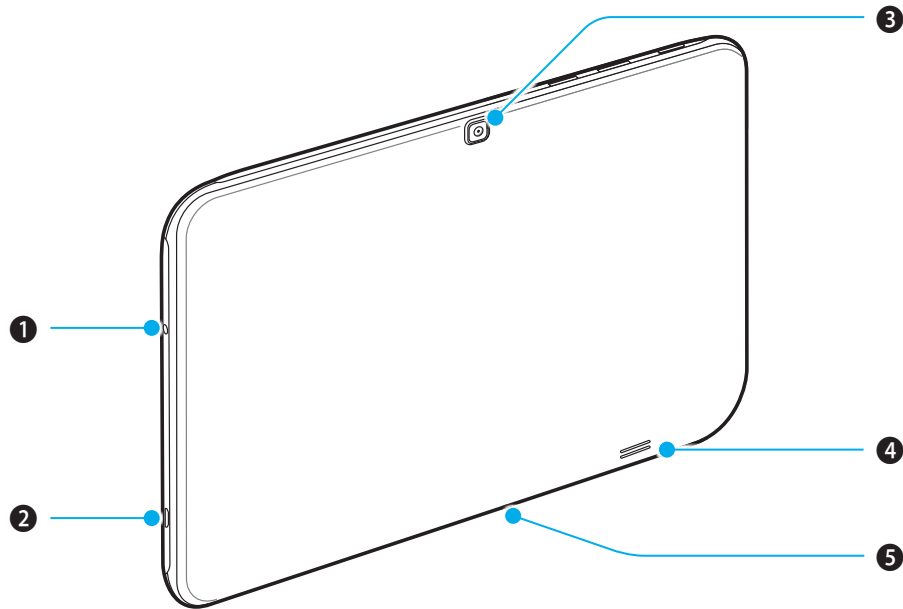

No.	Name	Description
1	Power port	Connects to the power adapter to charge the device.
2	USB port	Connects to USB devices, such as memory sticks, keyboards, and external hard drives.
3	Rear camera	Captures photos and video (5 megapixels).
4	Speaker	Emits sound.
5	Cradle connector	Connects the device to a cradle (optional).



2.5 Cradle Front (Optional)

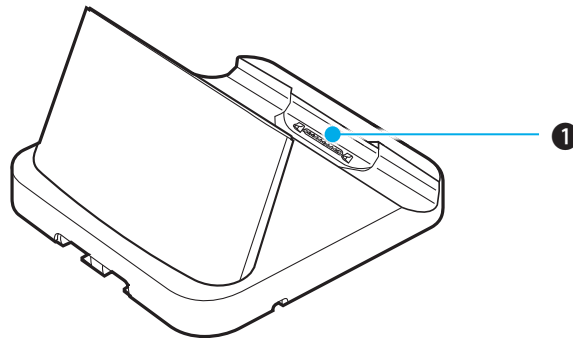

No.	Name	Description
1	Connector	Connects the cradle to a device.

2.6 Cradle Bottom (Optional)

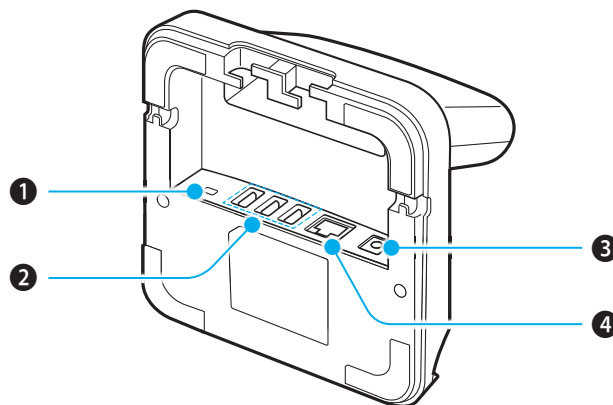

No.	Name	Description
1	DC OUT port	Connects another power source.
2	USB port	Connects to USB devices, such as memory sticks, keyboards, and external hard drives.
3	DC IN port	Connects a power cable.
4	Ethernet port	Connects an ethernet cable.

3 Getting Started



This chapter explains the basics of how to use the device, including how to charge the device, and turn it on or off. Subsequent chapters teach you how to navigate Windows or Android and customize the device, but the information in this chapter will help you start the device for the first time and configure basic settings.

3.1 Inserting a USIM Card

USIM cards allow the device to connect to mobile networks.

Insert the USIM card into the slot until you hear a click.

- Make sure that the gold-colored contacts are facing up.



Do not insert the USIM card into an incorrect slot. Check the shape and orientation of the slot to ensure that it is designed for a USIM card.



To remove the USIM card, see *10.2 Removing a USIM Card on page 30*.

3.2 Charging the Device

The device charges when connected to the power adapter or resting in the cradle (optional).



- Do not attempt to charge the device with anything other than the adapter it shipped with.
- Charge the device fully before using it for the first time. Failure to do so may decrease the life of the battery.

To Charge with the USB Cable

1 Plug the USB cable into the port.

- The battery LED turns red when the battery is charging.
- The battery LED turns white when the battery is fully charged.
- The battery LED blinks red and white alternately at 1 second intervals when the battery has a problem, such as it being too hot or too cold



Continuing to charge the device when the battery is full will not damage the battery.

3 Safety Precautions



- 2 Connect the USB cable to the power adapter.
- 3 Plug the adapter into an outlet.
- 4 After the battery is fully charged, unplug the USB cable.

To Charge with the Cradle (Optional)

- 1 Install the device into the cradle.
- 2 Connect the power adapter into the DC IN port of the cradle.
- 3 Connect the AC power cord into the adapter and an outlet.

3.3 Turning On the Device

Press and hold the power button on the back of the device to turn on the device.



To turn off the device, see [4.9 Turning Off the Device on page 15](#).

The power button is also used:





- To turn off the screen without turning off the device.
To turn the screen back on, press the power button again.
- To turn off the device manually by pressing and holding the power button for about five seconds.

3 Safety Precautions

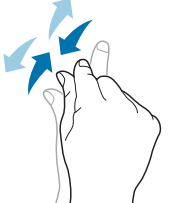

3.4 Using Touch Gestures

Touch gestures allow you to interact with Windows or Android and the applications installed on the device.

Gesture	Name	Description
	Tap	Lightly touch an item to launch apps, interact with buttons, and select options.
	Zoom	Touch two points on the screen and move your fingers together to zoom out or move them apart to zoom in.
	Press and hold	Continue touching an item to open context menus and display other options.
	Swipe	Flick your finger across the screen to switch between apps and display additional menus.
	Drag	Move your finger across the screen to move apps and pages.



3.5 Starting the Device for the First Time (Windows)

When you start the device for the first time, you are prompted to create a user account and configure basic settings.

To configure Windows upon initial startup, follow these steps:

- 1 When the **Region and language** screen appears, select the desired **Country or region**, **App language**, **Keyboard layout**, and **Time zone**, and then tap **Next**.
- 2 On the **Product key** screen, type the Windows product key that came with the device or tap **Skip** to perform this step later.
- 3 Read and consider the license terms, and then tap **I accept** if you agree to the terms.
- 4 When the **Personalize** screen appears, select a color theme and name for the device, and then tap **Next**.

 The **PC name** cannot contain spaces.

- 5 On the **Get online** screen, tap an available Wi-Fi or mobile network or tap **Skip this step** to perform this step later.
- 6 On the **Settings** screen, tap **Use express settings** to use the default Windows settings or tap **Customize** to manually configure Windows settings.
- 7 On the **Your account** screen, type a **User name**, **Password**, and **Password hint**.
- 8 When the device restarts and the lock screen appears, swipe up on the screen.
- 9 Tap your profile name, and then type in your password to start Windows.

4 Windows 8.1 Tutorials



Windows 8.1 includes features optimized for touch screens, such as the new **Start** screen, **Charms** menu, and gestures for switching and closing apps. The next few sections will teach you about these features and help you feel comfortable in this new environment.

4.1 Start Screen

The **Start** screen provides easy access to the apps and information most important to you. From the **Start** screen, you can see your calendar, email, and favorite websites, search for apps or content on the web, or log in and out of the device.



You can customize the **Start** screen by re-sizing the tile or adding a new tile. For more information, see *Configuring the 8.1 Configuring the Start Screen on page 21*.

4.2 Desktop

The desktop provides a familiar experience to those who have used previous versions of Windows. It is also where you will use certain apps, such as the File Explorer and Office applications.



 If you want to boot directly into the desktop, see *8.5 Booting to the Desktop on page 25*.



4.3 Charms Menu

The **Charms** menu provides quick access to frequently used functions from any screen. The functions in the **Charms** menu may differ based on the current app.



To open the **Charms** menu, follow these steps:

- 1 Swipe in from the right edge of the screen.

4 Windows 8.1 Tutorials



2 Tap the desired charm:

Icon	Name	Function
	Search	Finds things on the device or the web.
	Share	Shares files, photos, or links from the current app.
	Start	Opens the Start screen or desktop.
	Devices	Allows you to play, print, or project from peripheral devices.
	Settings	From apps: Changes the settings for the current app. From the Start screen and desktop: Changes Windows settings.

4.4 Switching between the Start screen and desktop

- 1 Swipe in from the right edge of the screen.
- 2 In the **Charms** menu, tap **Start**.

4.5 Apps Screen

The **Apps** screen displays all of the applications installed on the device. The apps that you use most frequently appear on the left side of the **Apps** screen. The other apps are grouped by publisher.



4 Windows 8.1 Tutorials



To show all of the apps installed on the device, follow these steps:

- 1 Place your finger in the center of the **Start** screen and swipe upwards.
- 2 On the **Apps** screen, swipe to the left or right to show more apps.

 You can swipe up from the bottom of the screen to display the context menu. The context menu allows you to pin apps to the **Start** screen or taskbar, uninstall apps, run apps as an administrator, or open app locations.

4.6 Switching Between Apps

- 1 Drag your finger inwards from the left edge of the screen.
- 2 Drag the app to the center of the screen, and release the app thumbnail.

 You can swipe in repeatedly from the left side of the screen to quickly cycle through all open apps.



4.7 Viewing Two Apps at Once

To display two apps at the same time:

- 1 From any app, drag your finger inwards from the left edge of the screen.



- 2 When the second app appears, drag it to the left or right side of the screen.
- 3 Release the app.

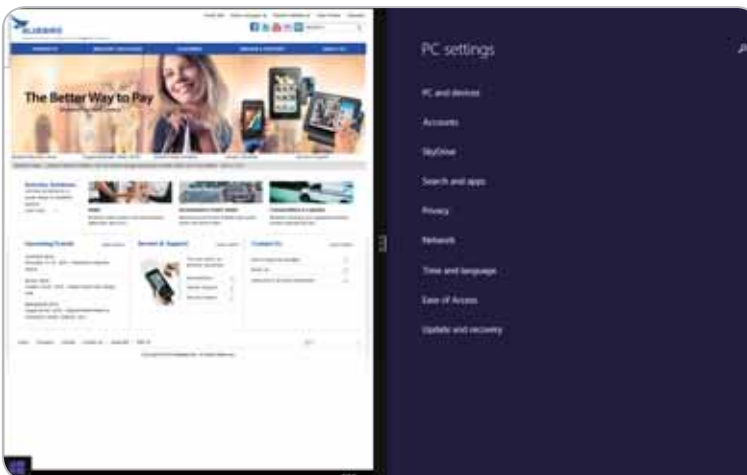

! You can press and drag the dividing line in the center to resize the apps.



4.8 Closing Active Apps

- 1 From the app, slide your finger downwards from the top edge of the screen.



- 2 When the app snaps to the bottom of the screen, release it.

 If the app appears in the window, tap the close button in the top right corner of the window.

4.9 Turning Off the Device

- 1 In the top right corner of the Charms screen, tap the  button.
- 2 Tap **Shut Down**.

 If the device is not responding, press and hold the power button on the top left edge of the device for about five seconds to turn off the device manually.



5 Connecting to Networks (Windows)



The device can connect to Wi-Fi and mobile wireless networks. The device can connect to Wi-Fi networks right out of the box, but you will need to insert a USIM card to connect to mobile networks. Connecting to and using mobile networks may incur charges from your mobile carrier.



You can also use Bluetooth to connect peripheral devices, such as keyboards and cell phones, to this device. In order to connect a Bluetooth device to this device, you must enable Bluetooth on both devices.

5.1 Connecting to a Wi-Fi Network

- 1 Swipe in from the right edge of the screen.
- 2 In the **Charms** menu, tap  **Settings**.
- 3 In the **Settings** sidebar, tap the  icon.
- 4 Tap the Wi-Fi toggle to enable Wi-Fi connections.
- 5 When the list of Wi-Fi networks appears, tap an available network.
- 6 Tap **Connect**.
- 7 Type in the password to connect to the network.

 After you connect to a Wi-Fi network, the device will automatically connect to that network whenever it is within range.

5.2 Connecting to a Mobile Network

- 1 Insert a USIM card (*10.1 Inserting a USIM card on page 30*).
- 2 Swipe in from the right edge of the screen.
- 3 In the **Charms** menu, tap  **Settings**.
- 4 In the **Settings** menu, tap .
- 5 In the **Networks** menu, under **Mobile Networks**, verify the connection status.





5.3 Sharing a Mobile Connection

To share a connection to a mobile network with other devices, follow these steps:

- 1 Swipe in from the right edge of the screen.
- 2 In the **Charms** menu, tap  **Settings**.
- 3 In the **Settings** menu, tap **Change PC settings**.
- 4 In the **PC settings** menu, tap **Network**.
- 5 Under **Mobile broadband**, tap the name of the network to share.
- 6 Under **Share this connection**, tap the toggle switch to turn on network sharing.
- 7 Specify the name of the network and the password.
- 8 On the other device, locate the network and enter the password to log in.

5.4 Disconnecting from a Network



- 1 Swipe in from the right edge of the screen.
- 2 In the **Charms** menu, tap  **Settings**.
- 3 In the **Settings** sidebar, tap the  icon.
- 4 Tap the Wi-Fi network with the **Connected** status, and then tap **Disconnect**.

6 Connecting to Networks (Android)



6.1 Connecting to a Wi-Fi Network

Connecting to a Wi-Fi network is an easy way of accessing the Internet. When you are out, you can connect to Wi-Fi networks in public places, such as libraries or coffee shops.

- 1 On the Home screen, tap  > .
- 2 Make sure switch the Wi-Fi to **ON**.
- 3 Tap the network you want to join.
- 4 If necessary, enter the password for the network and tap **Connect**.



To close the connection, switch the Wi-Fi to **OFF**.

 Your device periodically checks for and notifies you of available connections. The notification appears briefly at the top of the screen.

6.2 Connecting to a Mobile Network

Insert a USIM card (*3.1 Inserting a USIM Card on page 06*).

6.3 Sharing a Mobile Connection

- 1 On the Home screen, tap  > .
- 2 Tap **More...** > **Tethering & portable hotspot**.
- 3 Tap the **Bluetooth tethering** checkbox to share the data connection with other devices via Bluetooth.

7 Connecting to External Devices



7.1 Connecting to a Bluetooth Device (Windows)

- 1 Swipe in from the right edge of the screen.
- 2 In the **Charms** menu, tap **Settings**.
- 3 At the bottom of the **Settings** sidebar, tap **Change PC settings**.
- 4 In the **PC Settings** menu, tap **PC and devices**.
- 5 In the **PC and devices** menu, tap **Bluetooth**.
- 6 Tap the **Bluetooth** toggle to enable Bluetooth.
- 7 Tap the device that you want to pair with.
 - If the desired device does not appear in this list, then confirm that Bluetooth is enabled in the **Settings** menu of that device
- 8 Tap **Pair**.
- 9 Follow the instructions on the screen to finish pairing the device.

After you pair a Bluetooth-enabled device, the tablet will automatically pair with that device whenever it is within range and Bluetooth is enabled.

7.2 Connecting to External Devices (Android)

- 1 On the Home screen, tap > .
- 2 Make sure switch the Bluetooth to **ON**.
 - Make sure the devices you want to pair with have Bluetooth enabled.
 - You may need to start the pairing process from the headset. For details, see your headset user guide.
- 3 On the Bluetooth device list, tap the device you want to pair with.
- 4 Type or confirm the PIN, and tap PAIR, if required.
 - The passcode, which you can create, must be entered on both devices. The PIN in some devices is fixed. For details, see the user guide of the other device.
 - A PIN is only used when you connect to something for the first time.

When your device has paired with other devices via Bluetooth, your devices will automatically pair in the future when in range.



7.3 Connecting to USB Devices

- 1 Plug the USB cable into the port.



Before you connect a USB device, make sure that the connector is oriented correctly and that it can physically fit into the port.

- 2 When the notification appears, the device is ready to use.



The USB port supports USB 2.0 and 3.0 devices, such as mice, keyboards, and portable hard disks. However, the USB device may not function properly if it requires a current of more than 0.9 A.

8 Customizing the Device (Windows)



After learning how to navigate Windows and getting a feel for the device, you will probably want to customize its style and functionality. You can customize the **Start** screen, lock screen, and function buttons easily by following the instructions in this section.

8.1 Configuring the Start Screen

The **Start** screen is where it all begins, so you should add your own flair to make it your own. In this section, you'll learn how to change the background and color scheme of Windows, add, delete, and resize tiles, and arrange the **Start** screen to suit your preferences.

Changing the Background

To change the background of the **Start** screen:

- 1 Swipe in from the right edge of the screen
- 2 In the **Charms** menu, tap **Settings**.
- 3 In the **Settings** menu, tap **Personalize**.
- 4 Tap the desired **background**, **Background color**, and **Accent color**.

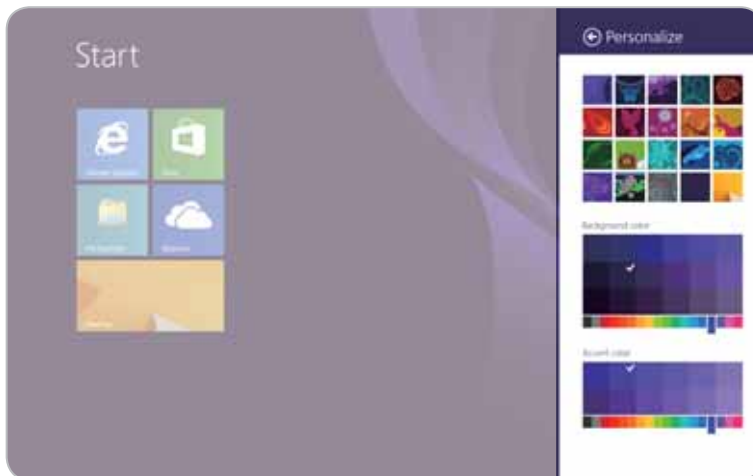

8 Customizing the Device (Windows)



Adding Tiles

Tiles allow you to add your favorite apps, websites, and contacts directly to the **Start** screen.

- 1 Place your finger in the center of the **Start** screen and swipe upwards.
- 2 On the **Apps** screen, press and hold an app until the context menu appears at the bottom of the screen

 To add multiple apps at the same time, tap the desired apps while the context menu is open.

- 3 In the context menu, tap  **Pin to Start**.



Removing Tiles

- 1 On the **Start** screen, press and hold an app until the context menu appears at the bottom of the screen.
- 2 Tap the tiles that you wish to delete.
- 3 In the context menu, tap  **Unpin from Start**.

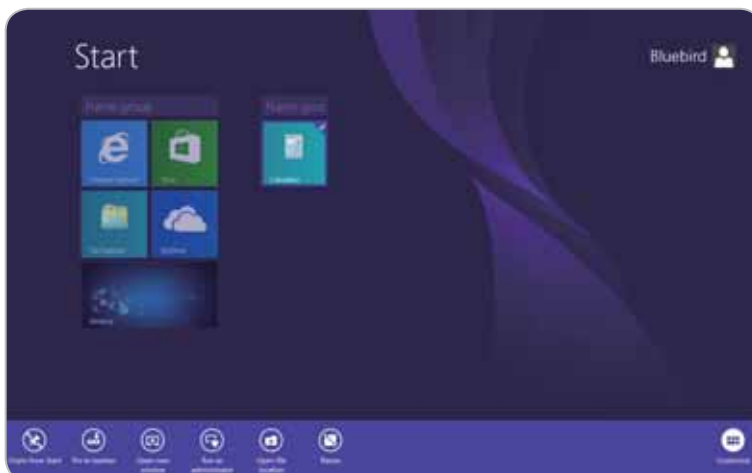

8 Customizing the Device (Windows)



Resizing Tiles

- 1 On the **Start** screen, press and hold the app until the context menu appears at the bottom of the screen.
- 2 In the context menu, tap  **Resize**.

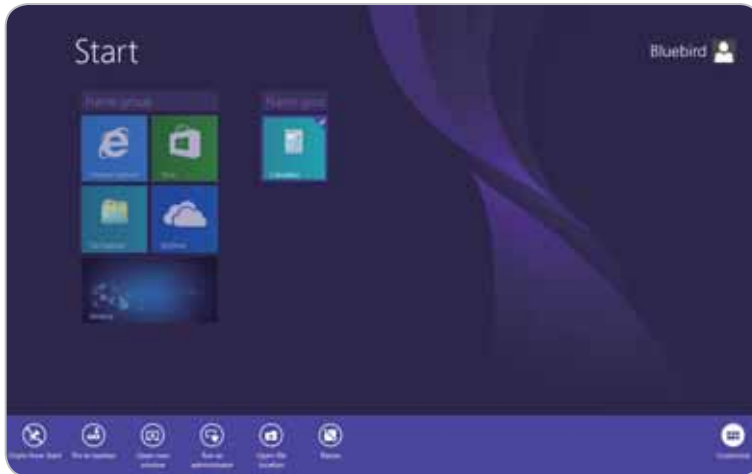

- 3 Tap the desired size.

Grouping Tiles

You can group tiles based on function, frequency of use, or even personal preference. Once grouped, the tiles will remain together until moved to another group or removed from the Start screen.

- 1 On the **Start** screen, press and hold an app until the context menu appears at the bottom of the screen.
- 2 Drag the app to the desired group or drag the app to a blank area of the screen to create a new group.



8 Customizing the Device (Windows)



- 3 Release the app.
- 4 After grouping all of the desired apps, tap the **Name group** textbox above the group to name the group.



8.2 Changing Your Account Picture

To change the picture associated with your Microsoft account, follow these steps:

- 1 Swipe in from the right edge of the screen.
- 2 In the **Charms** menu, tap **Settings**.
- 3 In the **Settings** menu, tap **Change PC settings**.
- 4 In the **PC Settings** menu, tap **Accounts**.
- 5 In the **Accounts** menu, tap **Your account**.
- 6 Choose a photo source:
 - Tap **Browse** to use a photo stored on the device.
 - Tap **Camera** to take a new photo using the camera on the device.

8.3 Personalizing the Lock Screen

- 1 Swipe in from the right edge of the screen.
- 2 In the **Charms** menu, tap **Settings**.
- 3 In the **Settings** menu, tap **Change PC settings**.
- 4 In the **PC settings** menu, tap **PC and devices**.
- 5 In the **PC and devices** menu, tap **Lock screen**.
- 6 Change options that you want to personalize.

8 Customizing the Device (Windows)



8.4 Setting the Date and Time

- 1 Swipe in from the right edge of the screen.
- 2 In the **Charms** menu, tap  **Settings**.
- 3 In the **Settings** menu, tap **Change PC settings**.
- 4 In the **PC Settings** menu, tap **Time and language**.
- 5 In the **Date and time** menu, tap **Change** to set the date and time.

8.5 Booting to the Desktop

To boot to the desktop instead of the **Start** screen, follow these steps:

- 1 Swipe in from the right edge of the screen.
- 2 In the **Charms** menu, tap  **Search**.
- 3 In the **Search** box, type **Taskbar**.
- 4 In the search results, tap **Taskbar and Navigation**.
- 5 In the **Taskbar and Navigation properties** window, on the **Navigation** tab, select **When I sign in or close all apps on a screen, go to the desktop instead of Start**.
- 6 Tap **OK**.

8.6 Assigning Function Buttons

Function buttons allow you to access frequently used keys and apps quickly without having to open the virtual keyboard or **Charms** menu.

To assign a key or action to a function button, follow these steps:

- 1 Tap  in the tray. If the  icon does not appear in the tray, tap  to see more programs running in the tray.

8 Customizing the Device (Windows)



2 In the menu that appears in the bottom right corner of the screen, tap .



3 In the **Type** dropdown menu, select **None**, **Key event**, or **Run app**.

- **None:** The function button does nothing.
- **Key event:** The function button performs the same function as the associated key.
- **Run app:** The function button opens the specified app.

4 In the **Key select** dropdown menu, select a key.

- Select **Etc...** to specify a key in the Key code field.
- If you selected **Run app** as the **Type**, then specify the file path to the app.

5 Tap **Apply** to apply the changes.

8.7 Using Quick Settings

Quick settings allow you to enable or disable device features directly from the desktop.

To enable or disable a quick setting feature:

1 Tap  in the tray. If the  icon does not appear in the tray, tap  to see more programs running in the tray.

2 In the menu that appears in the bottom right corner of the screen, tap .



8 Customizing the Device (Windows)



3 Tap an icon to enable or disable that feature.



A white icon indicates that the feature is enabled.

A dark blue icon indicates that the feature is disabled.

Icon	Feature	Description
	Accelerometer	Measures the acceleration of the device along the x, y, and z axes.
	Ambient Light	Changes the brightness of the screen based on the light in the usage environment.
	Compass	Detects the direction that the device is facing.
	Gyroscope	Measures the rate of rotation of the device along the x, y, and z axes.
	GPS	Detects the location of the device.
	NFC	Allows the tablet to share information using near field communication (NFC).
	Bluetooth	Allows the device to connect to Bluetooth devices.
	Wi-Fi	Detects available Wi-Fi networks and automatically connects to saved Wi-Fi networks.
	WWAN	Detects available wireless wide area networks (WWAN) and automatically connects to saved WWANs.
	Autorotation	Rotates the screen based on the orientation of the device.

9 Customizing the Device (Android)



9.1 Customizing Your Home Screen

You can customize the Home screen by adding shortcuts and widgets.

Adding Shortcuts or Widgets

Shortcuts added on the Home screen allows you to access and launch apps or activate a feature quickly and easily. Widgets appear as on-screen apps.

On the Home screen, tap  to view your all apps under the **APPS** tab or all widgets under the **WIDGETS** tab. Locate an app or widget, and tap and hold the item until the Home screen appears. Position the item on the screen and release.

 The same shortcuts or widgets can be added to any of the available screens.

Arranging Shortcuts or Widgets

Tap and hold the shortcut icon or widget you want to move. Drag the shortcut icon or widget to a new location. To place the item on a different page, drag it to the edge of the screen.

Removing Shortcuts or Widgets

Tap and hold an shortcut icon or widget. Drag it to **X Remove** at the top of the screen. When the item turns red, release it.

9.2 Using Your Device with Ease

Make it easier to see, hear, and use the device with its built-in accessibility features.

On the Apps screen, tap  > **Accessibility** and make the text size bigger, delay the touch and hold time, and more to fit your individual needs.

Quick Actions

Access the most frequently used settings quickly with quick action, turning them on or off in an instance.

9 Customizing the Device (Android)



- 1 Drag down from the top right of the screen at any time from any app and tap a quick action button to turn it on or off.

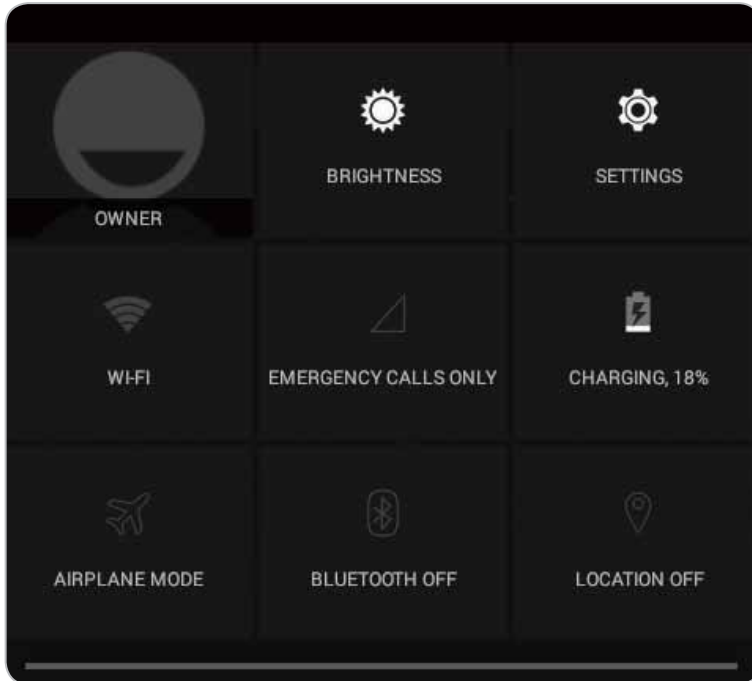

- 2 Drag up from the bottom of the screen or tap the Back button ←.

Setting Date and Time

The date and time are automatically set based on the network you are connected to.

To set the date and time manually

On the Apps screen, tap > **Date & time**, then disable **Automatic date & time**. If you turn off this option, the options for setting date and time will be activated.

To set the date and time automatically

On the Apps screen, tap > **Date & time**, then enable **Automatic date & time**.

To set the date and time format

On the Apps screen, tap > **Date & time**, then turn **Use 24-hour format** on or off.

Setting the Keyboard and Language

On the Apps screen, tap > **Language & input** to change the language and the keyboard you use.

Adjusting the Screen Brightness

- 1 On the Apps screen, tap > **Display** > **Brightness**.
- 2 Tap and move the slider to adjust the screen brightness.

10 Using the Card Slots



This chapter explains how to insert cards into the device.

10.1 Inserting a USIM card

See 3.1 *Inserting a USIM Card* on page 06.

10.2 Removing a USIM Card

- 1 Press the USIM card into the slot to release it.
- 2 Pull the USIM card to remove it.

10.3 Inserting a MicroSD card

MicroSD cards increase the storage capacity of the device.

Insert the microSD card into the slot until you hear it click.

- Make sure that the gold-colored contacts are facing up.





Do not insert the microSD card into an incorrect slot. Check the shape and orientation of the slot to ensure that it is designed for a microSD card.



10.4 Removing a MicroSD Card

- 1 Press the microSD card into the slot to release it.
- 2 Pull the microSD card to remove it.

10.5 Accessing Data on MicroSD Cards

- 1 Insert the microSD card into the device (see *10.3 Inserting a MicroSD card on page 30*).
- 2 Swipe in from the right edge of the screen.
- 3 In the **Charms** menu, tap  **Search**.
- 4 In the **Search** box, type **File Explorer**.
- 5 In the search results, tap  **File Explorer**.
- 6 In the pane on the left, tap **This PC**.
- 7 Under **Devices and drives**, tap the microSD card drive.

11 Using the Camera (Windows)



The Bluebird Camera app allows you to capture photos and record videos using either of the cameras on the device. After capturing photos or recording videos, you can then view the photos or videos stored on the device.

11.1 Installing the Camera App

- 1 Swipe upward on the **Start** screen to display the list of apps.
- 2 Tap  **Camera App Install** to open the link to the Windows Store.

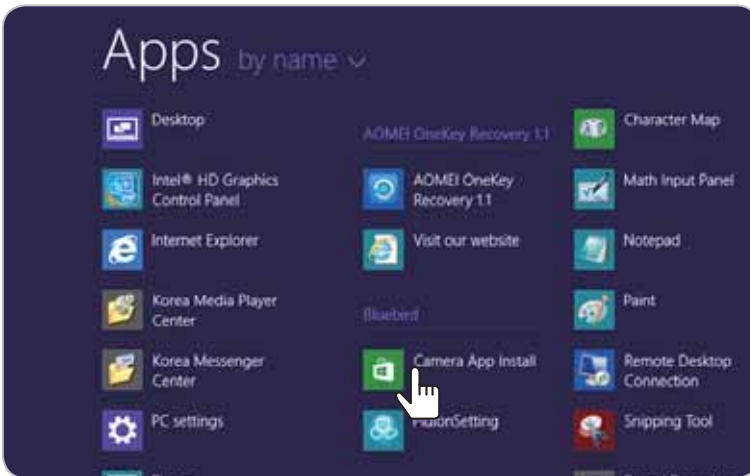

- 3 Tap **Install** to install the app.

- When you tap the **Install** button, you must enter your ID (email address) and password if you haven't logged in to your Microsoft account.
- The device must be connected to a network in order to install the Camera app.

11.2 Opening the Camera App

- 1 Swipe upward on the **Start** screen to see the list of apps.
- 2 Tap  **Bluebird Camera** to open the app.

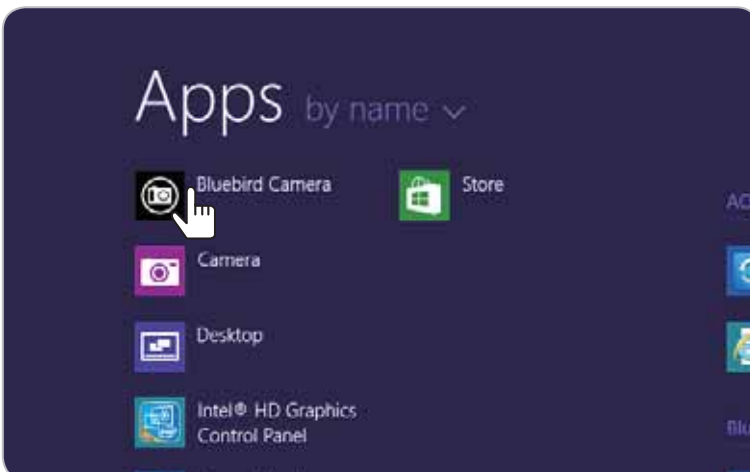

11 Using the Camera (Windows)





11.3 Taking Pictures



Ensure that the  icon appears in the top right corner of the screen. If the  appears instead, tap the icon to switch to photo mode.

Tap the **Capture** button to take the picture.





- Tap the resolution button in the lower right corner of the screen to change the resolution of the image.
- Tap  to reverse the image horizontally.
- Tap  to switch between the front and rear cameras on the device.

11.4 Recording Video

Ensure that  appears in the top right corner of the screen. If  appears instead, tap the icon to switch to video mode.

- 1 Tap **StartRecord** to start recording the video.
- 2 Tap **StopRecord** to stop recording the video and save it on the device.





- Tap the resolution button in the lower right corner of the screen to change the resolution of the video.
- Tap  to reverse the video image horizontally.
- Tap  to switch between the front and rear cameras on the device.





11.5 Viewing Photos

To view photos taken using the cameras on the device, follow these steps:

- 1 In the **Charms** menu, tap  **Search**.
- 2 In the **Search** box, type **File Explorer**.
- 3 In the search results, tap  **File Explorer**.
- 4 On the left side of the **File Explorer**, under **This PC**, tap the **Pictures** folder.
- 5 Double tap a photo in the folder to view it.

11.6 Viewing Videos

To view videos recorded using the cameras on the device, follow these steps:

- 1 In the **Charms** menu, tap  **Search** .
- 2 In the Search box, type **File Explorer**.
- 3 In the search results, tap  **File Explorer**.
- 4 On the left side of the **File Explorer**, under **This PC**, tap the **Videos** folder.
- 5 Double tap a video in the folder to view it.

12 Using the Camera (Android)





Use this app to take photos or record videos.

On the Apps screen, tap **Camera**.







- If a micro SD card is installed, the photos and videos will be saved on the internal storage.
- The first time you open the Camera app, you will be prompted to add location tags to your photos and display the information.

12.1 Taking Photos

- 1 On the Apps screen, tap **Camera** and make sure that camera mode is set to .
- 2 Aim the camera at the object and adjust the image. To zoom in or out, spread or pinch two fingers on the screen.
- 3 Tap  to take a photo.
Your device automatically focuses on the object and saves the photo in Gallery.
- 4 To view the photos taken, swipe the screen from the right edge.

12.2 Recording Videos

- 1 On the Apps screen, tap **Camera**.
- 2 Tap  >  to switch to video mode in the viewfinder.
- 3 Aim the camera at the object and adjust the image. To zoom in or out, spread or pinch two fingers on the screen.
- 4 Tap  to record a video.
- 5 Tap  to stop recording.
Your device automatically focuses on the object and saves the video in Gallery.
- 6 To view the recorded videos, swipe the screen from the right edge.

13 Maintenance and Troubleshooting



Despite its robust design, the device still requires a small amount of maintenance to continue operating optimally. Regular maintenance involves cleaning the touchscreen and ensuring the optimal battery life for the device. However, if you run into major problems with the device, then you may want to try the steps described in the Troubleshooting and Recovering Windows sections.

13.1 Cleaning the Touchscreen

During normal use, the touchscreen collects dust from the environment and grease from fingertips.

- 1 Dampen a lint-free cloth with water.



Do not use window cleaners or other chemical cleaners on the touchscreen. Doing so may damage the finish on the screen.

- 2 Wipe the entire screen in small circles.
- 3 Use a dry portion of the cloth to dry the screen.

13.2 Extending the Battery Life

The battery in the device provides all day power. However, certain settings and apps can quickly drain the battery.

To improve the battery life of the device, observe the following practices:

- Always charge the battery fully.
- Mute unnecessary sounds and vibrations, such as those related to keystrokes.
- Use headphones rather than the built in speaker.
- Exit the Camera app when you have finished taking photos.
- Turn off the Bluetooth and Wi-Fi networks when not in use.



To configure the power settings on the Windows device, follow these steps:

- 1 Swipe in from the right edge of the screen.
- 2 In the **Charms** menu, tap **Settings**.
- 3 In the **Settings** menu, tap **Change PC settings**.
- 4 In the **PC Settings** menu, tap **PC and devices**.
- 5 In the **PC and devices** menu, tap **Power and sleep**.
- 6 Configure the screen and sleep times for the device.

13 Maintenance and Troubleshooting



To decrease the length of the screen time-out and lower the screen brightness on the Android device, follow these steps:

- 1 On the Home screen, tap  > .
- 2 Tap **Display**.
- 3 Tap **Brightness** to adjust the brightness level or **Sleep** to set a shorter duration.

13.3 Troubleshooting

Attempt the following remedies before contacting the service center.

Issue	Remedy
The device got wet.	<ul style="list-style-type: none">• Allow the device to dry for at least 24 hours before you power on the device.• If the device does not power on, then contact your local service center.
The device won't power on.	Reset the device.
The battery won't charge.	<ul style="list-style-type: none">• Ensure that the power adapter is properly connected to the device and an outlet.• Clean the charging terminals with a dry rag.• If the device still doesn't charge, then contact your local service center for support.
The battery drains very quickly.	<ul style="list-style-type: none">• Check the Bluetooth, Wi-Fi, and brightness settings of the device.• If the battery drains quickly regardless of the power options, then contact your local service center for support.



13.4 Updating Windows

Unless you specify otherwise, Windows automatically downloads and installs updates when they become available. However, you may need to manually update Windows when you start the device for the first time or if Windows is not updating correctly.

To manually update Windows:

- 1 Plug in the device.



Do not unplug the device during the update process. Doing so may result in lost or damaged data.

- 2 Swipe in from the right edge of the screen.
- 3 In the **Charms** menu, tap **Settings**.
- 4 In the **Settings** menu, tap **Change PC settings**.
- 5 In the **PC Settings** menu, tap **Update and recovery**.
- 6 In the **Update and recovery** menu, tap **Windows Update**.

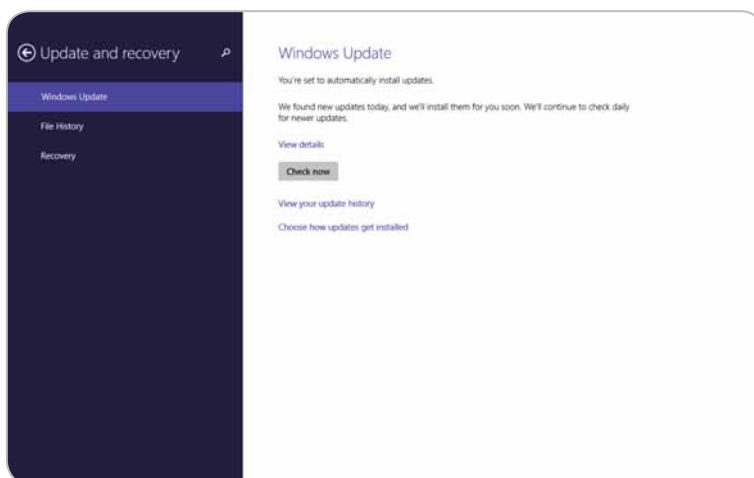

- 7 Tap **Check now**.
- 8 When Windows finishes searching for updates, tap **View details**.
- 9 In the list of updates, select all of the updates that you want to apply, and then tap **Install**.



You may need to provide an administrator password to install the updates. If prompted, enter your password to continue the installation process.

- 10 After the updates are installed, restart the device.



13.5 Backing Up Windows

Backing up the device creates a system image, which contains Windows as well as the applications, system settings, and files on the device. You can use this system image to recover the contents of the computer if a critical error occurs on the device.

- 1 On the **Apps** screen, tap  **AOMEI OneKey**.
- 2 When **AOMEI OneKey Recovery** loads, tap **OneKey System Backup**.



- 3 On the **System Backup** screen, specify where to create the backup image.
 - Select **Backup system to AOMEI OneKey Recovery Partition** to store the backup image on the device.
 - Select **Backup system to other location** to store the backup image on an external hard drive or network drive.
- 4 On the **Select Partition** screen, highlight the partition on which to create the recovery partition, and then click **Next**.
- 5 On the **Preview and Confirm** screen, examine the proposed changes to the partition allocations, and then click **Start Backup**.
- 6 When the dialog window appears to warn you that some operations require the computer to restart, tap **Yes**.
- 7 When the system restarts and the **Choose an operating system** screen appears, tap **Windows 8.1** to start Windows normally or tap **Enter into AOMEI OneKey Recovery** to recover the backup version.



13.6 Recovering Windows

Recovering Windows allows you to revert to a backup system image created using AOMEI OneKey. The backup image contains Windows as well as the applications, system settings, and files in the device when the backup was made. You may need to recover Windows if a critical error occurs on the device.

- 1 On the **Apps** screen, tap  **AOMEI OneKey**.

 You can also tap **Enter into AOMEI OneKey Recovery** on the boot menu to access AOMEI OneKey.

- 2 When **AOMEI OneKey Recovery** loads, tap **OneKey System Recovery**.



- 3 On the **Restore and Confirm** screen, highlight the partition on which to install the backup image, and then tap **Start Restore**.

 During recovery, the partition is formatted make room for the backup image. All data stored on the highlighted partition will be lost.

- 4 When the dialog window appears to warn you that system recovery requires the computer to reboot, tap **Yes**.

- 5 When the system restarts and the **Choose an operating system** screen appears, tap **Windows 8.1** to start the backup version of Windows or tap **Enter into AOMEI OneKey Recovery** to recover the backup version again.

 To restore the OS to its original state, press the reset button of the device using a small thin pointed piece like a pin. When the OS is restored to its original state, the drivers provided by Bluebird are not installed.

14 Help and Support



Bluebird is committed to ensuring that you get the most out of the device. If you encounter any problems while using the device, then please use the following methods to contact us for service and support.

14.1 Preparing for Service

You are responsible for backing up any important information or data before bringing the device for servicing. The repair process may require formatting or replacing the hard disk drive in the device, resulting in the loss of all data stored on the device.

14.2 Bluebird Customer Service

Customers Service Center

Telephone: +82-70-7730-8000

Fax: +82-2-548-0870

Email: RMA@bluebird.co.kr

Address: Customer Service Center

B-704, SSang-young IT Twintower

442-5 Sangdaewon-dong, Joongwon-gu,

Seongnam-si, Gyeonggi-do,

Republic of Korea

Operating Hours

Monday to Friday: 9:30 am – 6:30 pm (GMT +9 hours)

The center is closed on Saturdays, Sundays, and national holidays.



14.3 Conditions for After-sales Service

You must adhere to the following conditions in order to receive after-sales service:

- You must deliver the product to the service center through mail, a delivery service, or in person.
- You must enclose the device in protective packaging before delivering it to the service center. We recommend packaging the product in the box it came in.
- Bluebird is not responsible for any damage or loss that may occur during delivery, and such damage will not be repaired under warranty.
- If you purchased the device from anyone other than an authorized reseller, then you must register the device before you can receive after-sales service.
- You must include a receipt or other evidence of the purchase when submitting the product for after-sales service.
- All service requests must include your name, telephone number, address, and a description of the symptoms.
- The label must not be damaged.

14.4 Charged Service

You must pay for service in the following cases:

- Damage due to misuse of the product, including the following:
 - Use of programs that could affect the hardware or core software in the device, such as programs to over-clock hardware components, force inputs into the system, or user-created software.
 - Loss of a required password or pin number.
 - Careless use of the product, such as dropping the device or submerging it in water.
 - Repair by the customer or an unauthorized technician.
 - Damage due to natural causes, such as flooding, lightning, or fire.
 - Exhaustion of the lifespan of a component, such as the battery or antenna.
-  • Bluebird will repair a component free of charge if that component receives the same damage within 60 days of being repaired.
- Bluebird will exchange or provide after-sales service to repair damage that occurs to the device within 10 days of the purchase date. However, you may not return the device for a refund.



Physical Characteristics

Dimensions (W x H x D)	254 x 172 x 9.9 mm (10 x 6.7 x 0.38 inch)
Weight	700 g (1.54 lb)
Display	10.1"(1280x800) IPS, 10 point multi-touch, Direct Bonding, Gorilla Glass
Storage	16 GB eMMC / 32 GB eMMC (Optional)
Keypad	Volume Up/Down, Power Virtual
Battery	6000 mAh, 3.8 V
Expansion Slot	Micro SDXC up to 64 GB
SIM / SAM Slots	1 SIM slot
Audio	Mono, ear-jack (4pin for mic, Water Proof)
Cameras	Front: 2 megapixel fixed focus Rear: 5 megapixel auto focus
Interfaces	Docking Connector (10 pin), 1 USB host
GPS	S-GPS, A-GPS, Glonass, BeiDou
Sensors	G-Sensor, Light
Power Management	Charging Status LED For USB Charge 5 V, Cradle charge 12 V for fast charging

Performance Characteristics

CPU	Quad Core 1.83 GHz
OS	Windows Embedded 8.1 Industry Pro, Windows 10 IoT Enterprise, or Android 4.4
Memory	1 GB / 2 GB (Optional)



User Environment

Operating Temp.	-10°C to 60°C (14°F to 140°F)
Storage Temp.	-20°C to 65°C (-4°F to 149°F)
Humidity	90% non-condensing
ESD	± 8 kv Air, ± 4 kv Contact

Wireless

WWAN	GSM/GPRS/EDGE 850/900/1800/1900MHz WCDMA/HSDPA/HSUPA/HSPA+ 850/900/1700/1900/2100MHz
WLAN	802.11 a/b/g/n (2.4 G and 5 G) with support for the following security measures: WPA, WPA2, 802.1X, WEP, AES-CCMP, and TKIP
WPAN	Bluetooth v4.0 LE



Cradles

- One Slot Cradle: Charging only
- One Slot Ethernet Cradle: Charging port, 3 USB 2.0 ports, 1 Ethernet port, 1 DC-in

 A power adapter (80001144) and a country-specific AC power cord (80001133 ~ 80001140) are required to use the charging feature.

Vehicle accessories

- Vehicle charger
- Vehicle mount

Other Accessories

- Blue Pen
- Soft Plastic Screen Guard (Anti-Finger Print Coated, Sunlight Readability Enhanced)
- Soft Plastic Screen Guard (Scratch-Proof High Glossy)

 Use only the adapter listed below.
Manufacturer: Borasen Fuyuang Electronic Co.,Ltd
Model: FY1206000
Input: 100-240 V, 50-60 Hz
Output: 12V/6A.



FCC compliance information

This device complies with Part 15 of the FCC's Rules. Operation is subject to the following two Conditions:

- This device may not cause harmful interference, and
- This device must accept any interference received, including interference that may cause undesirable operation.

This device complies with part 15 of the FCC Rules. Operation is subject to the condition that this device does not cause harmful interference.

End users cannot modify this transmitter device. Any Unauthorized modification could void the user's authority to operate this device.

This device was tested for typical body-worn operations with the back of the handset kept 0.39 inches (1cm) between the user's body and the back of the handset.

To comply with FCC RF exposure requirements, the handset must be kept 0.39 inches (1cm) from the body without any reference to a particular side or edge.

Any beltclips, holsters, and similar accessories containing metallic components may not be used.

Body-worn accessories that cannot maintain 0.39 inches (1cm) separation distance between the user's body and the handset, and have not been tested for typical body-worn operations may not comply with FCC RF exposure limits and should be avoided.

Part 15.105 (B)

This equipment has been tested and found to comply with the limits for a Class B digital device, pursuant to part 15 of the FCC Rules. These limits are designed to provide reasonable protection against harmful interference in a residential installation. This equipment generates, uses and can radiate radio frequency energy and, if not installed and used in accordance with the instructions, may cause harmful interference to radio communications. However, there is no guarantee that interference will not occur in a particular installation. If this equipment does cause harmful interference to radio or television reception, which can be determined by turning the equipment off and on, the user is encouraged to try to correct the interference by one or more of the following measures:

- Reorient or relocate the receiving antenna.
- Increase the separation between the equipment and receiver.
- Connect the equipment into an outlet on a circuit different from that to which the receiver is connected.
- Consult the dealer or an experienced radio/TV technician for help.

Modifications not expressly approved by the manufacturer could void the user's authority to operate the equipment under FCC rules.



IEC 60417-6044



Do not listen to sound at high volume for long periods. It may cause hearing damage. Also, only use compatible receiver, headphones, or earpieces with your device.

CE



Hereby, Bluebird Inc. declares that this RFR900 is in compliance with the essential requirements and other relevant provisions of directive 1999/5/EC.

To comply with CE RF exposure requirements, the handset must be kept 0.59 inches (1.5cm) from the body without any reference to a particular side or edge.

Any beltclips, holsters, and similar accessories containing metallic components may not be used.

Body-worn accessories that cannot maintain 0.59 inches (1.5cm) separation distance between the user's body and the handset, and have not been tested for typical body-worn operations may not comply with CE RF exposure limits and should be avoided.

European Union (EU) Waste of Electrical and Electronic Equipment (WEEE) directive



According to the European Union's WEEE directive, this symbol means that products sold into EU countries must dispose electrical device and/or its battery separately from household waste. Disposing of the device separately will help conserve resources and energy and contribute to human health and environment protection.

Customers or end-users in EU countries should contact their local equipment supplier representative or service centre for information about the waste collection system in their country.



Certificate

Product Name	
Model Name	ST100
Date of Purchase	
Serial Number	
Purchase Location	
Warranty Term	1 year from date of purchase

Warranty Terms

Bluebird Inc. (hereinafter referred to as Bluebird) provides warranty service for its products in compliance with the relevant regulations and the terms of the warranty.

Upon receiving notification of a defect in a product covered by the warranty terms, Bluebird will repair or replace the defective product according to its warranty policy.

If the defective product covered by the warranty cannot be repaired or replaced, Bluebird shall refund the purchasing price within a period designated after the date that the defect notice is received.

Bluebird assumes no responsibility for repairing, replacing, or refunding a product until it receives the defective product from the customer. All replacement products shall be equal to the original product in terms of performance.

The Bluebird warranty is valid only in countries in which Bluebird distributes its products. (An additional contract is necessary for additional service, such as field service.)

Bluebird products may contain recycled components or materials that are equal to new components or materials in terms of performance.

This warranty applies to software products only when the programming commands are not executed. Bluebird does not guarantee interruption-free or error-free performance.

If the customer loses the receipt or warranty certificate, then the warranty period will be 3 months after the date of manufacture indicated by the serial number.

Bluebird shall service only those accessories that appear on the sales list of the service center. Any repair or replacement of accessories that do not appear on the sales list will be at the customer's expense.

CE RF Radiation Exposure Statement:

Caution This equipment complies with European RF radiation exposure limits for SAR (Specific Absorption Rate). This transmitter must not be co-located or operating in conjunction with any other antenna or transmitter.



BLUEBIRD CUSTOMER SERVICE

Operating Hours

Monday to Friday 9:30 A.M. - 6:30 P.M.
(GMT Time: +9 Hours)

The center is closed on Saturdays,
Sundays, and national holidays.

Customers Service Center

B 703, SSang-young IT twintower,
442-5 Sangdaewon-dong, Joongwon-gu,
Seongnam-si, Gyeonggi-do, Republic of Korea

Bluebird constantly strives to bring utmost satisfaction to all our customers.