

AVL-GSM User Installation Manual

2011.5.04

BNB Solutions Co., Ltd.

FCC Information to User

This equipment has been tested and found to comply with the limits for a Class B digital device, pursuant to Part 15 of the FCC Rules. These limits are designed to provide reasonable protection against harmful interference in a residential installation. This equipment generates, uses and can radiate radio frequency energy and, if not installed and used in accordance with the instructions, may cause harmful interference to radio communications. However, there is no guarantee that interference will not occur in a particular installation. If this equipment does cause harmful interference to radio or television reception, which can be determined by turning the equipment off and on, the user is encouraged to try to correct the interference by one of the following measures:

- Reorient or relocate the receiving antenna.
- Increase the separation between the equipment and receiver.
- Connect the equipment into an outlet on a circuit different from that to which the receiver is connected.
- Consult the dealer or an experienced radio/TV technician for help.

Caution

Modifications not expressly approved by the party responsible for compliance could void the user's authority to operate the equipment.

FCC Compliance Information : This device complies with Part 15 of the FCC Rules. Operation is subject to the following two conditions: (1) This device may not cause harmful interference, and (2) this device must accept any interference received, including interference that may cause undesired operation

IMPORTANT NOTE:

FCC RF Radiation Exposure Statement:

This equipment complies with FCC RF radiation exposure limits set forth for an uncontrolled environment. This equipment should be installed and operated with a minimum distance of 20 centimeters between the radiator and your body. This transmitter must not be co-located or operating in conjunction with any other antenna or transmitter.

Revision

version	date	revision basis	engineer name	reason of revision
0.0	2011.03.10		Son, Ki-bong	draft
0.1	2011.05.04		Son, Ki-bong	I/O Port Modify

List of Contents

1. Introduction.....	4
2. Composition.....	4
1) Basic components.....	4
2) Accessories for separate sale	5
3. Main body of the AVL-GSM.....	6
1) Front	6
2) Rear	7
4. Product specification.....	10
5. RF specification.....	10
1) GSM operating frequency	10
2) GSM Antenna.....	10
3) GPS Antenna	10
6. Installation	12

1. Introduction

This machine is a device to transmit car locations in real time through the GSM network with the embedded GSM module and GPS module to the designated server. You can check a current location and route on the Web. Also you can enjoy more diverse and more convenient functions with RS-232 telecommunication by installing accessories additionally

2. Composition

1) Basic components

- (1) Main body of the AVL GSM



- (2) (GSM+GPS) unified antenna



- (3) Power cables



- Color: TBD

- Length: 3M

2) Accessories for separate sale.

(1) Thermograph & interface cable

Install a temperature sensor at the place to measure the temperature. You may measure the temperature by installing it at a car cargo section. Send the measured temperature data to the AVL-GSM, which transmits the data to the designated server.



(2) Digital tachograph and interface cable

This product installed in the car provides in real time the information including car overspeed, idling, quick-acceleration, and quick-deceleration. It is recommended to install the digital tachograph at a garage or the designated shop.



(3) Panic button

In case of emergency, press the button to the server. The following picture shows a button as an example.

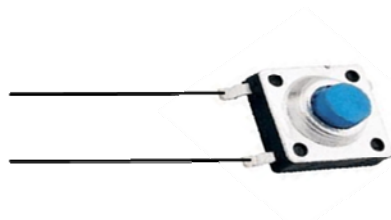

(4) Keypad

After connecting it with the body of AVL-GSM, if you press each button, its applicable information is transmitted to the server.



(5) Relay and cable

The followings are the exterior relay for car ignition interlock and cables.

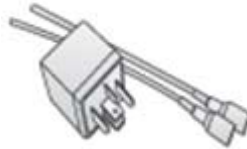

3. Main body of the AVL-GSM

1) Front

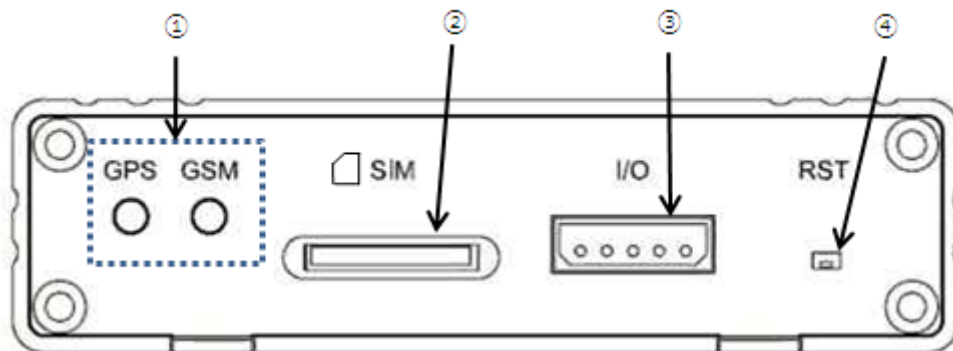

① Status indicating LED

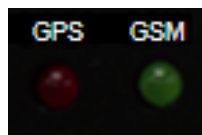

- GPS LED is a red LED and blinks every second when a GPS module works normally.
- GSM LED is a green LED and blinks during the storage of the data to be transmitted by the terminal. While data is transmitted to the server, it stays on and becomes off after transmission.

② SIM: port to insert a SIM card

③ I/O: 5 pin connector of a Molex 5268A type

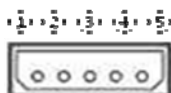

PIN NO	Description
①	Panic Button: optional (3) connected with a panic button
②	Not used
③	Not used
④	Car_Stop_Out: optional (5) connected with a car ignition interlock relay
⑤	Ground

④ RST: Reset switch

2) Rear

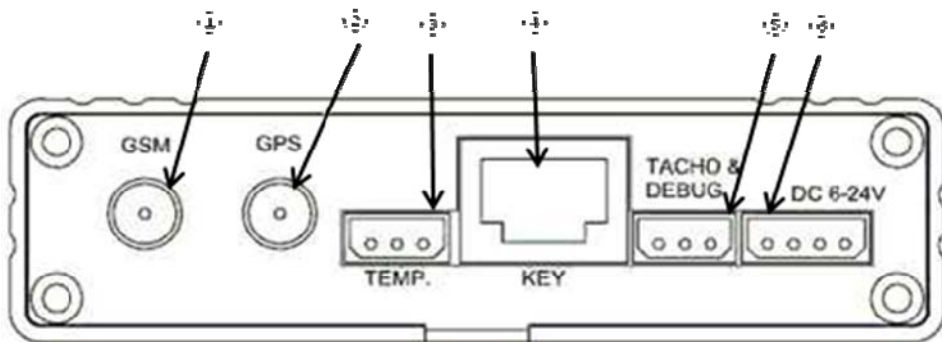

① GSM



It is a SMA type connector to be connected with a GSM cable of (GSM+GPS) unified antenna. Be careful not to connect the GSM cable of (GSM+GPS) unified antenna with the below GPS connector.

② GPS



It is a SMA type connector to be connected with a GPS cable of (GSM+GPS) unified antenna. Be careful not to connect the GPS cable of (GSM+GPS) unified antenna with the above GSM connector.

③ TEMP

It is a 3 pin connector of a Molex 5268A type to be connected with (1) thermograph, an optional accessory. Be careful not to connect the thermograph with the "TACHO & DEBUG" port explained hereunder.



PIN NO	Description
①	TEMP_TX232
②	GND
③	TEMP_RX232: It receives data of the thermograph.

④ KEY

It is a RJ45 connector to be connected with (4) keypad, an optional accessory.

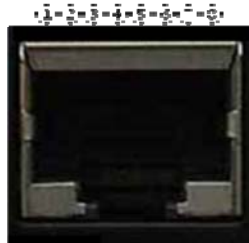

PIN NO	Description
①	KEY_GPIO_1
②	KEY_GPIO_2
③	KEY_GPIO_3
④	KEY_GPIO_4
⑤	Ground
⑥	KEY_GPIO_5
⑦	Not used
⑧	3.3V

⑤ TACHO & DEBUG

It is a 3 pin connector of a Molex 5268A type for firmware downloading or to be connected with (2) digital tachograph, an optional accessory. Be careful not to be connected with the above mentioned thermograph.



PIN NO	Description
①	TACHO_DEBUG_TX232
②	GND
③	TACHO_DEBUG_RX232

⑥ DC 6-24V

It is a 5268A 4Pin connector of Molex type to be connected with power cable.



PIN NO	Description
①	VCC_IN: Connect this with a car battery + terminal (12V or 24V)
②	Battery_BackUp: Connect this to the power inlet (cigar jack or radio power socket) after turning on the car ignition key, or connect to "IGN1", "IGN2", or "ACC" pin according to the automobile manual.
③	Ground: Connect this with a car battery – terminal (Ground).
④	Ground: Connect this with a car battery – terminal (Ground).

Connect the power cables in the picture below with the above pin numbers correctly.

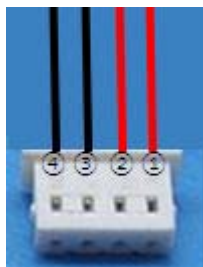

4. Product specification

Item	Description
Processor	STM32F103RC
Size	24 mm x 90 mm x 62.4 mm
Weight	165g ± 10%
Input power	DC 11 ~ DC 30V
Operating temperature	-20°C ~ 60°C
Power consumption	80mA@12V, Battery Full charge(Typical) 300mA below@12V, Battery charging (It varies as the battery charge state) 200mA@12V (It varies as TX, GSM network state)
Inside battery	Lithium polymer 3.7V/650mA

5. RF specification

1) GSM operating frequency

Mode	Freq. TX(MHz)	Freq. RX(MHz)	Channels(ARFCN)	TX-RX Offset
GSM850	824.2 ~ 848.8	869.2 ~ 893.8	128 ~ 251	45MHz
E-GSM-900	890.0 ~ 914.8	935.0 ~ 959.8	0 ~ 124	45MHz
	880.2 ~ 889.8	925.2 ~ 934.8	975 ~ 1023	45MHz
DCS-1800	1710.2 ~ 1784.8	1805.2 ~ 1879.8	512 ~ 885	95MHz
PCS-1900	1850.2 ~ 1909.8	1930.2 ~ 1989.8	512 ~ 810	80MHz

2) GSM Antenna

- Impedance: 50Ω
- Frequency: 824~894 MHz, 880 ~ 960 MHz, 1710 ~ 1880 MHz, 1850 ~ 1990 MHz
- Gain: 2dBi ±1 dB@850 MHz, 2dBi ±1 dB@900 MHz, 1dBi ±1 dB@1800 MHz, 1dBi±1 dB@1900 MHz
- V.S.W.R: 2.0:1

3) GPS Antenna

- Impedance: 50 Ω
- Gain: > -4dBic at -90° < 0 < +90°(over 75% Volume)
- Peak Gain: > 3dBic Based on 7×7cm ground plane

- Center Frequency: 1575.42MHz±3 MHz
- V.S.W.R: 1.5:1

6. Installation

1) How to use basic functions

GPS location of the car is transmitted by GSM network, and such location and route can be identified in the web.

- (1) (GSM+GPS). A "GSM" printed cable of (GSM+GPS) unified antenna is connected with ① GSM connector in the picture below. A "GPS" printed cable is connected with ② GPS connector in the picture below.

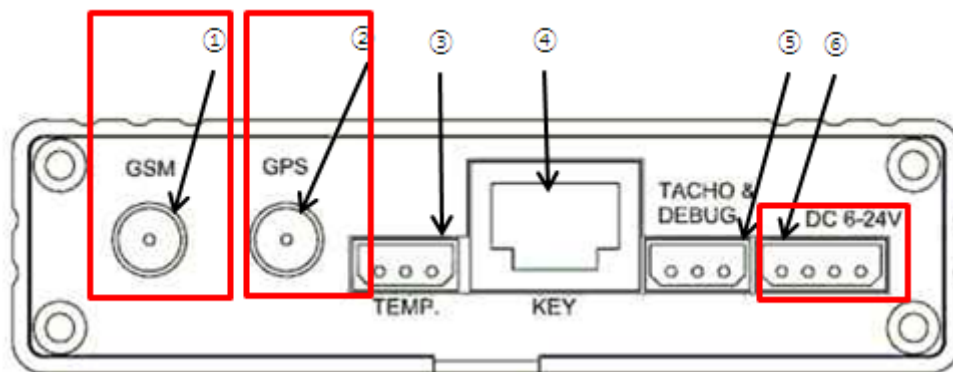

- (2) Connect the power cable with ⑥ DC 6-24V connector in the above picture. Connect Cable 1 with the car battery + terminal (12V or 24V), and connect Cable 2 with the power inlet (cigar jack or radio power socket) after turning on the car ignition key, or connect this with IGN1(IGNITION 1), IGN2(IGNITION 2), or ACC pin according to the car manual. Connect Cable 3 & 4 with the car battery – terminal(Ground).

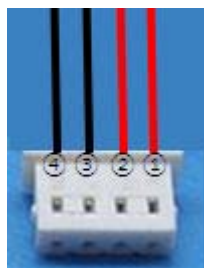

- (3) After connecting as above, put the SIM card into ② SIM card socket in the picture below, and press ④ Reset one time.

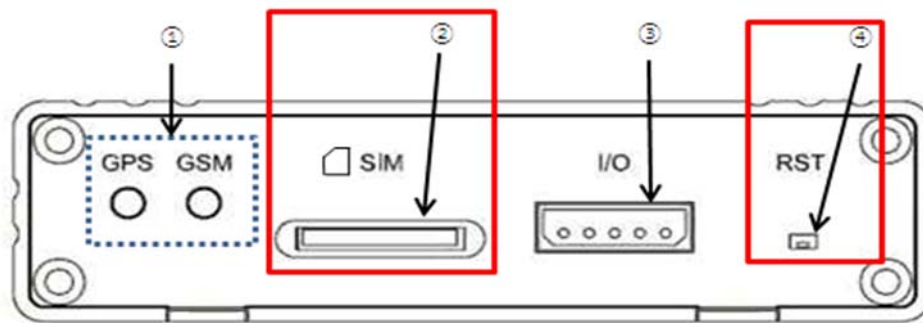

- (4) After about 1 minutes, check if ① GPS Red LED in the above picture blinks one time per second. If it does not blink, check again the connections of the power cable and the GPS antenna cable. Afterwards, check if the data comes up to the designated server.

2) How to use a thermograph

To use a thermograph, change the setting of thermograph as follows. However, the setting may differ from the models of thermograph, you need to pay attention to suitability.

- (1) Connect the thermograph with the AVL-GSM Rear ③TEMP using the supplied telecommunication cable.

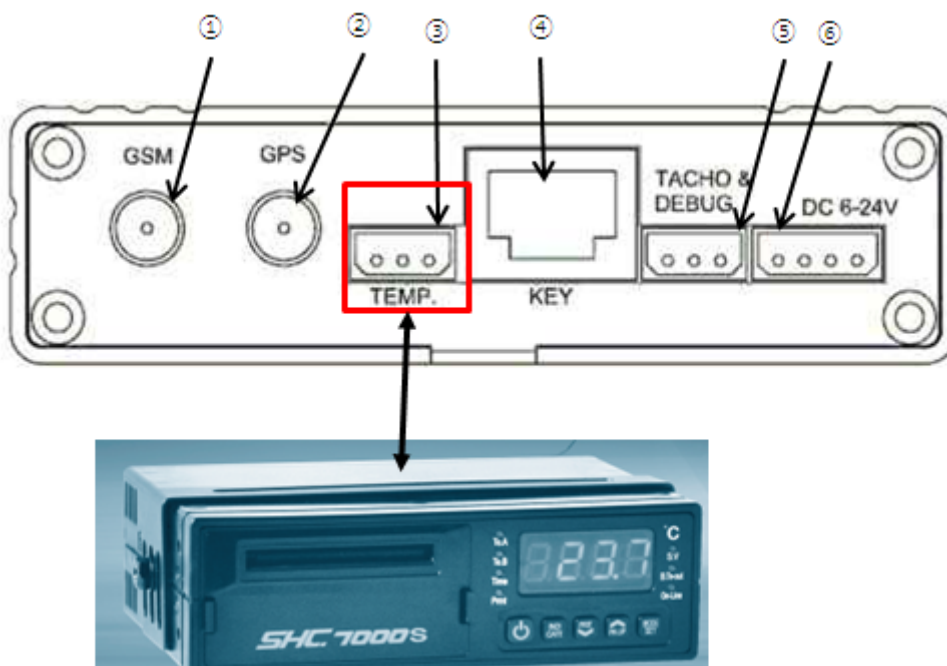

- (2) Turn on the power of the thermograph.

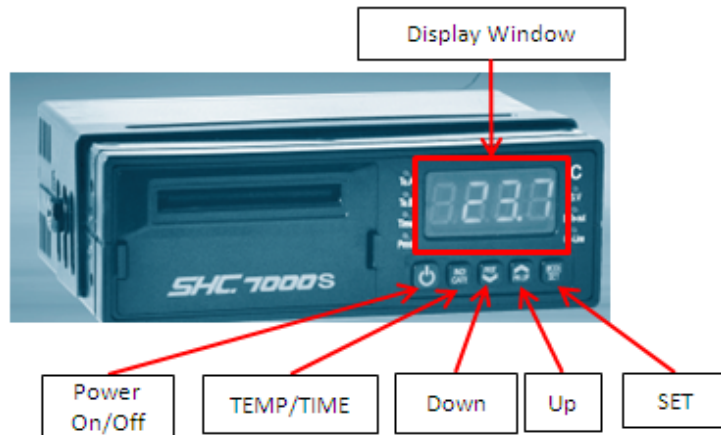

- (3) If you continue to press the Temperature/time button of thermograph, the contents in the display window of thermograph appears in the following sequence.

In about 6 seconds, "St01" is displayed. → In about 6 seconds, "Po-1" is displayed. → In about 6 seconds, "1234" (this is a car setting number which may differ from each thermograph.) is displayed. → In about 6 seconds, "Ut1"(or "Ut2" or "Ut3") is displayed.

- (A) When Ut1 is displayed

When Ut1 is displayed, if you take your hand off from the Temperature/time button and press again the Temperature/time button, PF-A or PF-n is displayed.

- (B) When Ut2 or Ut3 is displayed

When Ut2 or Ut3 is displayed, take your hand off from the Temperature/time button and press the up ↑ or the down ↓ button for a change into Ut1, and press the Temperature/time button for storage. At the time of storage, PF-A or PF-n is displayed.

- (4) If PF-A is displayed in the above, press the up ↑ or down ↓ button for a change into PF-n, and press once again the Temperature/time button for storage.

- (5) Press again the Temperature/time button to check if PF-n is displayed. If PF-A is displayed, press the up ↑ or down ↓ button for a change into PF-n, the press the Temperature/time button to finish the setting.

3) How to use a tachograph

When you use a digital tachograph, connect the port of digital tachograph with ⑤ TACHO&DEBUG port of the AVL-GSM Rear using the supplied telecommunication cable.

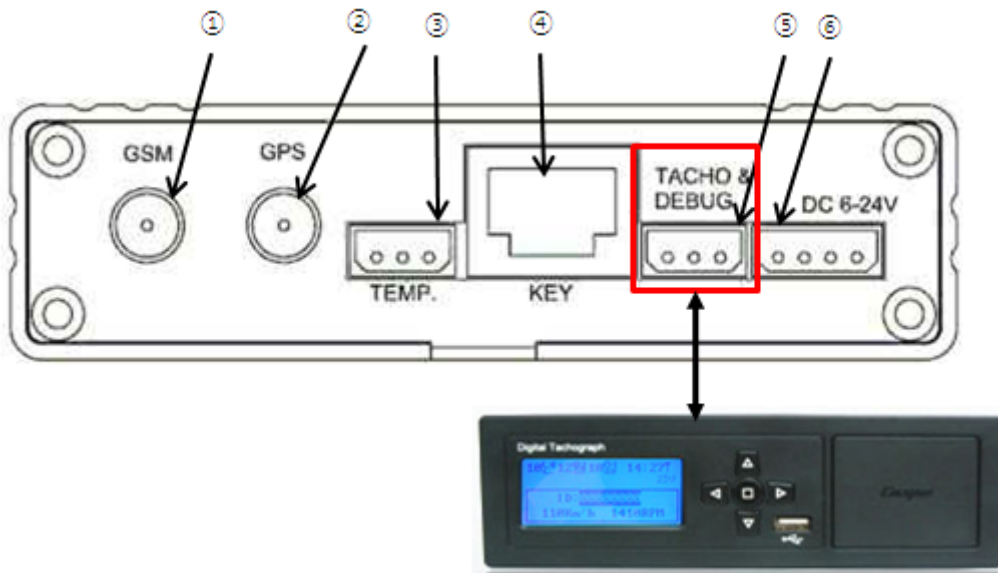

When you install the digital tachograph, refer to the "Instruction manual of digital tachograph"

4) How to use a keypad

Use a keypad by connecting the cable of keypad with the Key port as shown in the picture.

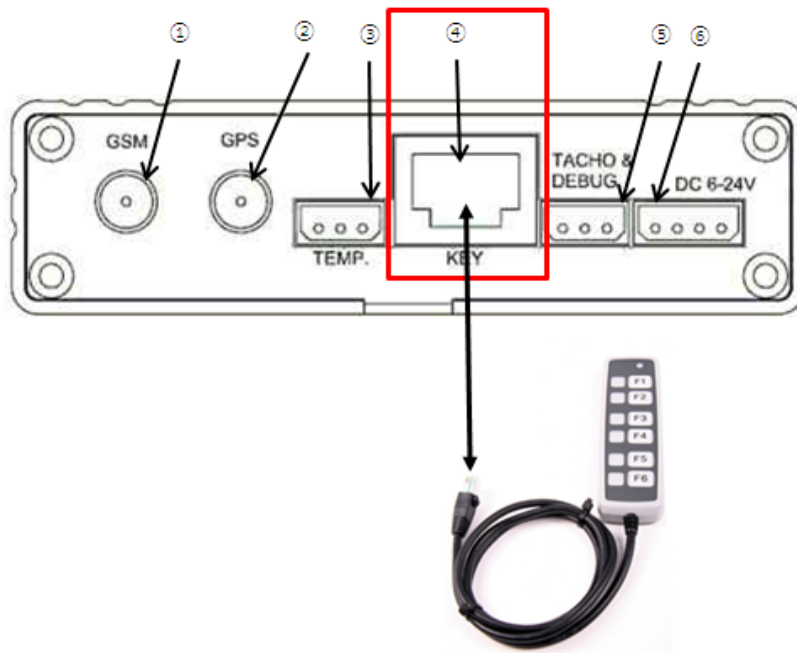

You can use F1 to F5 in the keypad. If you push each button, its applicable information is transmitted to the server. Functions in the keypad may be changed depending on the operating company. For example: F1 – car departure, F2 – cargo loading finish, F3 – cargo unloading finish, F4 – car arrival. If you push the Key among F1 ~ F5, the LED in the keypad blinks and the LED in the keypad stays on during the transmission to the server. If transmission to the server is completed, the LED gets off.

5) How to use a car ignition interlock function

This terminal can be remotely controlled to avoid ignition during the operation or stop. When a car is stolen and its starter is off, this device does not allow the ignition again to operate the car. Care must be paid since remote control during the car operation is very dangerous

To control the car ignition, the relay as in the picture below is required. Choose a suitable relay to the car battery voltage from those for 12V and 24V.

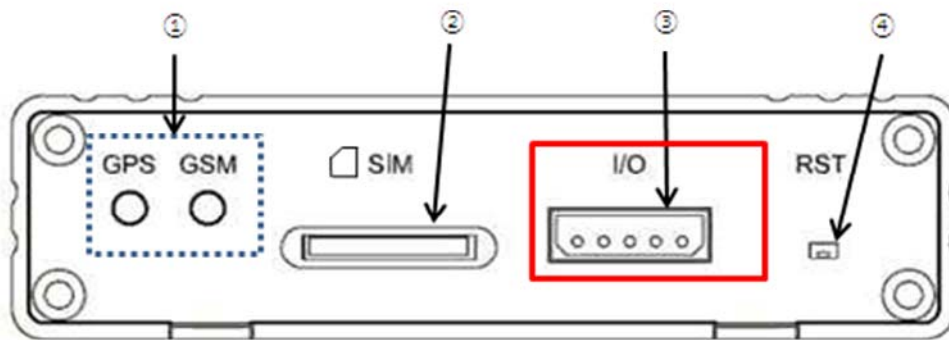
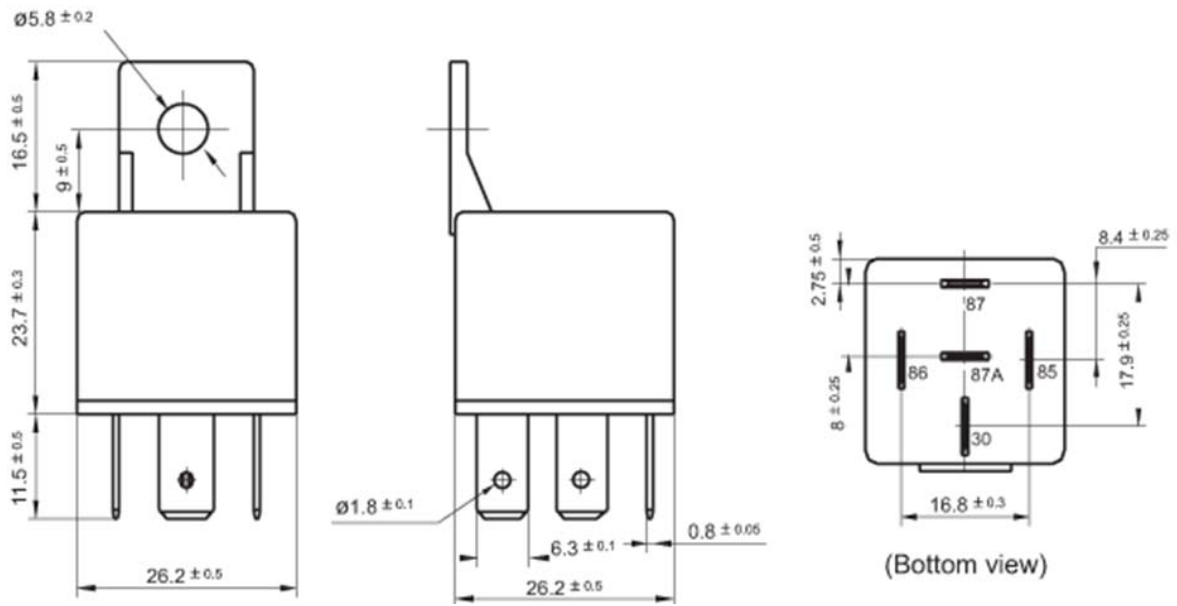

Connect the pin number 85 of relay in the below picture with the number 4 of ③ I/O connector in the above picture. And connect the pin number 30 and 86 of relay with the battery + terminal (12V or 24V). Connect 87A pin of the relay to the power source of car fuel pump. For a car ignition interlock, it interrupts the power of the fuel pump system to prevent ignition.

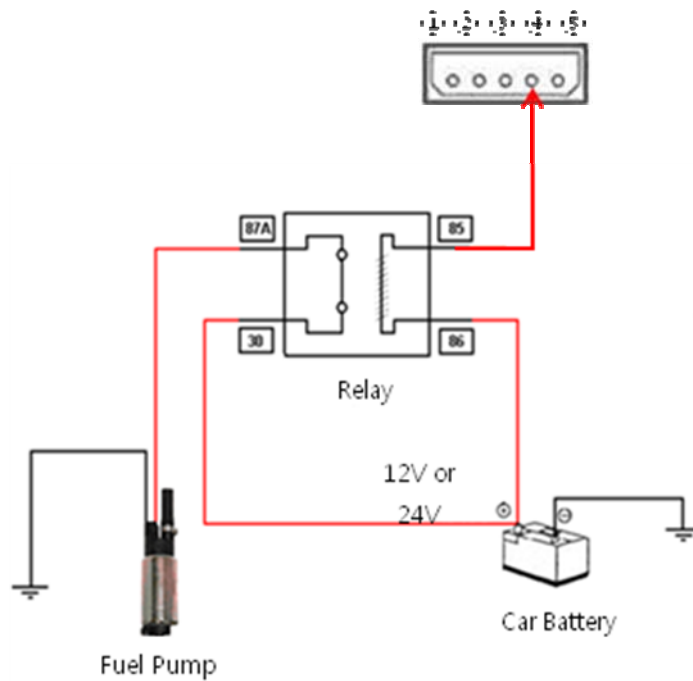

6) How to use a panic button

It is a button for emergency in the car. If you push on and take off, the terminal informs emergency to the server. Install it at a not-well visible place in the car. Connect one end of the panic button to the Ground as shown in the picture, and connect the other end to the number 1 of ③ I/O connector of the AVL-GSM front. You may install more than one panic button.

