

Bolens®

Owner/Operator Manual

Riding Mower

Models

- 13000 8 HP 28" side discharge
- 13001 8.5 HP 28" side discharge
- 13002 8.5 HP 28" side discharge (Export)
- 13003 12.5 HP 33" mulcher
- 13004 12.5 HP (Australia)
- 13005 12.5 HP 36" side discharge
- 13006 12.5 HP 36" side discharge (Export)
- 13007 12.5 HP 33" mulcher (Export)
- 13055 8 HP 28" side discharge
- 13057 8.5 HP 28" side discharge
- 13067 12.5 HP 33" mulcher
- 13068 12.5 HP 33" mulcher (Export)

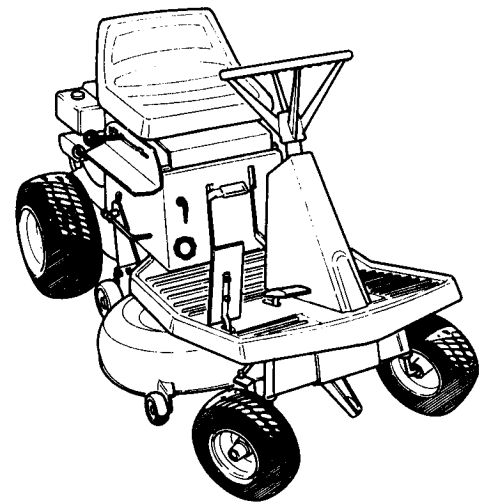

INTRODUCTION

Thank you for purchasing this Bolens® riding mower. We feel you now own one of the finest pieces of equipment available.

This is a safety, operation, and general maintenance manual which does not attempt to cover major repairs.

Bolens® equipment is carefully designed, engineered and manufactured to give good performance if properly operated and maintained. Review this manual to familiarize yourself with the unit, its features, and its operation.

All Bolens® mowers have passed rigid safety standards of the Outdoor Power Equipment Institute and an independent testing laboratory.

Your Warranty Statement is included, on the back cover of this manual. Please read it carefully. Also please return the completed postpaid owner registration card which is included with this manual. Proper registration is required for all warranty claims.

IDENTIFICATION NUMBERS

For prompt service when repairs or adjustments are required, your authorized Bolens® dealer must have the identification numbers of your riding mower. Please fill in the identification numbers in the spaces below for future reference. Your identification numbers are located under the seat as shown to the right.

Date of Purchase:

Mower Serial Number:

Transmission Model/Serial Number:

Engine Model/Serial/Spec. Numbers:

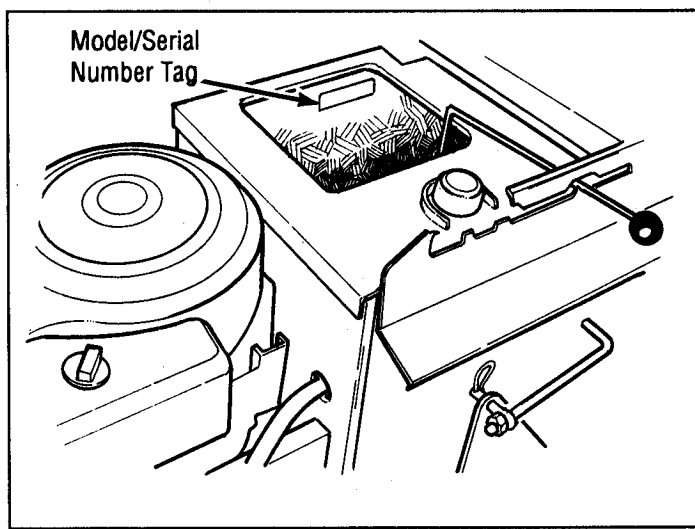

WARNING TO ALL CALIFORNIA AND OTHER RIDING MOWER OPERATORS



Under California law, and under the laws of several other states, you are not permitted to operate an internal combustion engine using hydrocarbon fuels on any forest covered, brush covered, or grass covered land, or on land covered with grain, hay, or other flammable agricultural crop, without an engine spark arrester in continuous effective working order.

The engine on your riding mower, like most outdoor power equipment, is an internal combustion engine that burns gasoline, a hydrocarbon fuel. Therefore, your riding mower must be equipped with a spark arrester muffler in continuous effective working order. The spark arrester must be attached to the engine exhaust system in such a manner that flames or heat from the system will not ignite flammable material. Failure of the owner/operator of the riding mower to comply with this regulation is a misdemeanor under California law, and may also be a violation of other state and/or federal regulations, laws, ordinances, or codes. Contact your local fire marshal or forest service for specific information about what regulations apply in your area.

TABLE OF CONTENTS

SAFETY	3	Starting	19
ATTACHMENTS AND KITS	6	Interlock System Test	20
SPECIFICATIONS	6	Mowing	20
ASSEMBLY	8	Testing Height of Cut	21
HITCH	8	Gage Wheel Adjustment	21
COLUMN SUPPORT	8	Stopping	22
BATTERY	8	Parking	22
SEAT	9	Mowing Tips	22
ENGINE OIL	9	Special Pattern Effects	22
SPARK PLUG	9	MAINTENANCE	23
MOWER DECK INSTALLATION	9-16	TRACTOR MAINTENANCE	23
CONTROLS AND OPERATION	18	Engine	23
CONTROLS	17	Brake Adjustment	23
Engine Speed Lever	17	Transmission Drive Belt Adjustment	23
Brake Pedal	17	Battery	24
Parking Brake	17	MOWER DECK MAINTENANCE	25
Ignition Keyswitch	17	Mower Drive Belt Replacement	25
Drive Pedal	17	Mower Drive Belt Adjustment	27
Mower Blade Drive Lever	17	Mower Deck Brake Adjustment	28
Mower Height Adjusting Knob	17	Blade Maintenance	29
Transmission Shift Lever	17	STORAGE	31
Mower Lift Lever	18	MAINTENANCE CHART	32
OPERATION	18	TROUBLESHOOTING CHART	32
Pre-Starting Checklist	18	WIRING DIAGRAM	35
Filling Fuel Tank	19	WARRANTY	BACK COVER

SAFETY

IMPORTANT!

Safe Operation Practices for Riding Mowers



This is a safety alert symbol. It is used in this Manual and on riding mower decals to alert you to potential hazards.

Whenever you see this symbol, read and obey the safety message that follows it. Failure to obey the safety message could result in personal injury or property damage.

TRAINING

PREVENTING ACCIDENTS IS THE RESPONSIBILITY OF EVERY EQUIPMENT OPERATOR. THE OPERATOR IS RESPONSIBLE FOR ACCIDENTS OR HAZARDS OCCURRING TO OTHER PEOPLE OR THEIR PROPERTY. THE FOLLOWING GENERAL SAFETY PRECAUTIONS MUST BE FULLY UNDERSTOOD AND FOLLOWED WHEN OPERATING YOUR RIDING MOWER. REVIEW THEM FREQUENTLY AND NEVER TAKE CHANCES. BE CAREFUL BEFORE, DURING AND IMMEDIATELY AFTER USE OF ANY POWERED EQUIPMENT. ACCIDENTS CAN BE PREVENTED.

1. Before operating the unit:
 - a. Read this owner/operator manual, the separate engine owner's manual, and any other literature you may have received.
 - b. Be thoroughly familiar with the controls and proper use of the unit.
 - c. Read all literature furnished with any attachments used on the unit.
 - d. Know how to stop the unit and disengage its controls quickly in case of an emergency.
2. NEVER allow children to operate the unit. Local regulations may restrict the age of the operator.
3. Do not allow adults to operate the unit without proper instruction.

4. Never allow irresponsible adults to operate the unit.
5. Keep the area of operation clear of all persons (particularly small children) and pets.

GENERAL OPERATION

1. Thoroughly inspect the area where the unit will be used:
 - a. Remove all stones, sticks, wires, bones, and other foreign objects. Tall grass can hide obstacles.
 - b. Inspect the area for holes, ruts, or bumps. Uneven terrain could overturn the unit.
2. Wear proper clothing before operating the unit:

SAFETY (Cont.)

- a. Do not operate the unit when barefoot or wearing open sandals. Always wear substantial footwear.
 - b. Always wear long trousers.
 - c. Do not wear loose-fitting clothing or jewelry that could get caught in moving parts.
 - d. Be aware that vines, branches, etc., can snag loose-fitting clothing or jewelry.
3. Before attempting to start the engine:
 - a. Apply the parking brake.
 - b. Disengage the mower blade drive.
 - c. Shift into neutral.
 4. Mow only in daylight or in good artificial light.
 5. Never operate the unit in wet grass—reduced traction could cause sliding. Always maintain proper traction. Keep a firm grip on the steering wheel. Never attempt to stabilize the unit by putting your foot on the ground.
 6. Use care when pulling loads or using heavy equipment:
 - a. Use only approved drawbar hitch points.
 - b. Limit loads to those you can safely control.
 - c. Do not turn sharply. Slow down before turning. Use care when backing up.
 - d. Use optional counterweight(s) or wheel weights when using attachments which affect the balance of the unit.
 7. Never attempt to defeat the purpose of guards or other safety devices installed on the unit. Never operate the unit with defective guards or shields, or without safety devices in place.
 8. Before use, always visually inspect the mower blade(s) and blade bolts and replace if they are worn or damaged. Replace worn or damaged blades and bolts in sets to maintain proper balance. Torque the blade bolts to the correct torque values indicated in this manual.
 9. If the unit has a two blade deck, use care when rotating one blade because this can cause the other blade to rotate.
 10. Use extra care when loading or unloading the unit into a trailer or truck.
 11. Before attempting to start the engine:
 - a. Apply the parking brake.
 - b. Disengage the mower blade drive.
 - c. Shift into neutral.
 12. Do not change the engine governor settings or over-speed the engine. Operating an engine at excessive speed may increase the hazard of personal injury.
 13. Do not put hands or feet near or under rotating parts. Keep clear of the discharge opening at all times. Be aware of the mower discharge direction and do not point it at anyone. Do not operate the unit without either the entire optional bagging attachment or the discharge chute in place.
 14. Watch for traffic when operating near, or when crossing roadways.
 15. Disengage the mower blade drive and wait for the mower blades to come to a stop when crossing gravel drives, walks, or roads.
 16. After striking a foreign object:
 - a. Disengage the mower blade drive.
 - b. Stop the engine.
 - c. Wait for all moving parts to come to a complete stop.
 - d. Remove the wire from the spark plug.
 - e. Keep the wire away from the plug to prevent accidental starting.
 - f. Thoroughly inspect the unit for any damage, and repair the damage before re-starting and operating the unit.
 17. If the unit should start to vibrate abnormally, stop the engine and check immediately for the cause. Vibration is generally a warning of trouble.
 18. Before cleaning the mower deck housing, before cleaning the unit and before making any repairs or inspections:
 - a. Disengage the mower blade drive.
 - b. Stop the engine.
 - c. Wait for all moving parts to come to a complete stop.
 - d. Remove the wire from the spark plug.
 - e. Keep the wire away from the plug to prevent accidental starting.
 19. Stop the engine whenever you leave the unit.
 20. Do not run the engine indoors. Exhaust gases contain carbon monoxide, a deadly gas that is odorless and colorless. Always run the engine outdoors and make sure there is adequate ventilation.
 21. Stop the blade (move the mower blade drive lever to its disengaged position) whenever you are approached by any child, inattentive person, or pet.
 22. Disengage the mower blade drive when you are not mowing.
 23. Do not touch engine parts which may be hot from operation. Allow the engine to cool before inspecting, cleaning, or repairing the unit.
 24. Do not operate the unit while under the influence of alcohol or drugs.
 25. Use low throttle settings when engaging the drive pedal, especially in high gears.
 26. Never attempt to carry any passengers on the unit. They could fall off and be seriously injured, or they could interfere with the safe operation of the unit.
 27. Use extra care when approaching blind corners, shrubs, trees, and any other object that may obscure vision.
 28. When using any attachments, never direct the discharge of material toward bystanders.
 29. There is a safety interlock switch which should shut down the engine within a few seconds after the operator leaves the seat. If this switch fails to operate, get the unit serviced immediately by an authorized Bolens® dealer. Severe injury could result from not following this instruction.
 30. Never leave a running machine unattended. Always disengage the mower blade drive, set the parking brake, stop the engine and remove the keys before dismounting.

SAFETY (Cont.)

SLOPE OPERATION

1. Mow up and down the face of a slope—Never across.
2. Keep all movement on a slope slow and gradual. Do not make sudden changes in speed or direction. Do not turn on slopes unless necessary, and then, turn slowly and gradually downhill, if possible. Use slow speed. Choose a low gear so you will not have to stop or shift while on the slope.
3. Do not stop or start suddenly on a slope. If the tires lose traction, disengage the mower blade drive and proceed slowly *straight* down the slope.
4. Do not mow steep slopes.
5. Do not mow near drop-offs, ditches, or embankments. If a wheel goes over the edge, or if the edge caves in, the unit could overturn.
6. Use extra care while using the optional model 6028 or 6036 grass collection attachments. These can change the stability of the unit. Use wheel- and/or counter-weights when using these attachments. Do not use them on steep slopes.

CHILDREN

1. Tragic accidents can occur if the operator is not alert to the presence of children. Children are often attracted to the unit and the mowing activity. *Never* assume that children will remain where you last saw them. Keep children out of the mowing area. Keep them under the watchful eye of an adult other than the person operating the unit.

Be alert and turn unit off if children enter the area.
2. Before backing up:
 - a. Look behind you and on the ground immediately behind the unit before backing up and while running in reverse.
 - b. Be sure to look down and behind you for small children. A large percentage of accidents involving children occur while backing up.
 - c. Disengage the mower blade drive before backing up.

SERVICE

1. Handle gasoline with care — it is highly flammable:
 - a. Use an approved gasoline container.
 - b. Never remove the fuel cap of, or add gasoline to, a running or hot engine or to an engine that has not been allowed to cool for several minutes after running.

Never store the unit or fuel container inside where there is an open flame, such as in a water heater.
 - c. Keep smoking materials, sparks, and flame away from the gas tank and the fuel container.
2. Check the fuel before starting the engine:
 - a. Do not fill the gasoline tank indoors, when the engine is running or until the engine has been allowed to cool for several minutes after operating.
 - b. Clean off any spilled gasoline before starting the engine.
3. Replace any worn or damaged parts.
4. Check the blade and the engine mounting bolts at frequent intervals for proper tightness.
5. Never store the unit with gasoline in the fuel tank inside a building where gasoline fumes could reach an open flame or spark.
6. When storing gasoline:
 - a. Store gasoline in a cool, well-ventilated area, safely away from any spark- or flame-producing equipment.
 - b. Store gasoline in an approved container, safely out of the reach of children.
7. If the fuel tank has to be drained, drain it outdoors.
8. Allow the engine to cool before storing this unit in any enclosure.
9. To reduce fire hazard, keep the engine free of grass, leaves, or excessive grease.
10. Check the (optional) grass catching bag. Under normal use, the bag's material is subject to deterioration and wear. It should be checked frequently and replaced when necessary. Use only a genuine Bolens® replacement bag.

11. Use only original-equipment replacement parts. Parts manufactured by others could present safety hazards even though they may fit on the unit.
12. Before inspecting, cleaning, adjusting, or repairing the unit:
 - a. Disengage the mower blade drive.
 - b. Stop the engine.
 - c. Wait for all moving parts to come to a complete stop.
 - d. Remove the wire from the spark plug.
 - e. Keep the wire away from the plug to prevent accidental starting.
 - f. Allow the engine to cool.
13. Keep all nuts, bolts, and screws tight to be sure the unit is in safe working condition.
14. Replace a worn or faulty muffler.
15. Do not allow children to be near you when you are servicing this unit.
16. Remove the battery, drain the fuel tank and drain the engine oil if it becomes necessary to tip the unit up on its end or on its side. Fluids can leak from the unit if it is tipped over.
17. Chock the wheels (place blocks of wood on both sides of the wheels) whenever you have to perform any maintenance that requires the parking brake to be off.
18. Mower blades are sharp and can cut. Wrap the blade(s) or wear gloves, and use extra caution when servicing them.
19. Check brake operation frequently. Adjust and service as required (See page 23).

DECALS

For your personal safety and the safety of others, safety message decals have been placed on your riding mower. Make sure these decals are in place, clean and legible at all times. Refer to the separate parts catalog for decal locations, part numbers, and ordering instructions.

ATTACHMENTS AND KITS

Below is a list of attachments and kits that are available for your unit. The information is the most current at the time this manual was printed. Check with your nearest Bolens® dealer for up-to-date information.

Kit Number	Description
6028	Power packer Bagging Attachment for 28" decks
6036	Power packer Bagging Attachment for 36" decks
6957	Storage Stand (Stands unit up on rear end for storage/maintenance.)
6958	Wheel Weights, 70lbs. (pair)

SPECIFICATIONS

Bolens® reserves the right to make changes in specifications shown herein, add improvements or discontinue the manufactured product at any time without notice or obligation.

Models 13000, 13001, 13002, 13055 & 13057		Tires.....Front: 11.00 x 4.00 x 5.00 Rear: 16 x 6.50 x 8.00
Engine.....	Models 13000 & 13055 --Briggs & Stratton Model 195707 Vertical shaft 8 HP (see engine manual for further details)	Turning Radius23" (58.4 cm)
	Models 13001, 13002 & 13057 --Briggs & Stratton Model 196707 Vertical shaft 8.5 HP (see engine manual for further details)	Height38.5" (98 cm)
Fuel Capacity.....	1 U.S. Gal. (3.7 Liters)	Width (at rear tires)32" (81 cm)
Electrical System	12v./160cca	Cutting Width.....33" (84 cm), mulching mower deck
Speed.....	High Gear: 4.0 MPH (6.5 Km/Hr) Low Gear: 1.2 MPH (1.9 Km/Hr) Reverse: 1.5 MPH (2.4 Km/Hr)	No. of Blades2
Tires.....	Models 13000 & 13055 Front: 4.10/3.50 x 8 Rear: 4.80/4.00 x 8	Cutting height range1" to 3" (2.5 cm to 7.5 cm)
	Models 13001, 13002 & 13057 Front: 11.00 x 4.00 x 5.00 Rear: 16 x 6.50 x 8	Weight350 lbs (159 Kilos)
Turning Radius	23" (58.4 cm)	
Height	38.5" (98 cm)	Model 13004
Width (at rear tires)	32" (81 cm)	Engine.....Briggs & Stratton Model 286707 Vertical shaft 12.5 HP (see engine manual for further details)
Cutting Width.....	28" (71 cm), side discharge mower deck	Fuel Capacity.....
No. of Blades	1	1 U.S. Gal. (3.7 Liters)
Cutting height range	1" to 3" (2.5 cm to 7.5 cm)	Electrical System
Weight	340 lbs (154 Kilos)	12v./160cca
		Speed.....
		High Gear: 4.0 MPH (6.5 Km/Hr)
		Low Gear: 1.2 MPH (1.9 Km/Hr)
		Reverse: 1.5 MPH (2.4 Km/Hr)
		Tires.....
		Front: 11.00 x 4.00 x 5.00
		Rear: 16 x 6.50 x 8.00
		Turning Radius
		23" (58.4 cm)
		Height
		38.5" (98 cm)
		Width (at rear tires)
		32" (81 cm)
		Cutting Width(s)
		28" (71 cm), side discharge; 33" (84 cm), mulching mower;
		36" (91 cm) side discharge
		No. of Blades
		1 (28"), 2 (33" & 36")
		Cutting height range
		1" to 3.25" (2.5 cm to 8.3 cm)
		Weight
		340 lbs (154 Kilos) to 360 lbs (163 Kilos)
Models 13003 , 13007, 13067 & 13068		
Engine.....	Briggs & Stratton Model 286707 Vertical shaft 12.5 HP (see engine manual for further details)	
Fuel Capacity.....	1 U.S. Gal. (3.7 Liters)	
Electrical System	12v./160cca	
Speed.....	High Gear: 4.0 MPH (6.5 Km/Hr) Low Gear: 1.2 MPH (1.9 Km/Hr) Reverse: 1.5 MPH (2.4 Km/Hr)	
		Models 13005 & 13006
		Engine.....Briggs & Stratton Model 286707 Vertical shaft 12.5 HP (see engine manual for further details)

SPECIFICATIONS (Cont.)

Fuel Capacity.....	1 U.S. Gal. (3.7 Liters)	Turning Radius.....	23" (58.4 cm)
Electrical System.....	12v./160cca	Height.....	38.5" (98 cm)
Speed.....	High Gear: 4.0 MPH (6.5 Km/Hr)	Width (at rear tires).....	32" (81 cm)
	Low Gear: 1.2 MPH (1.9 Km/Hr)	Cutting Width.....	36" (91 cm), side discharge mower deck
	Reverse: 1.5 MPH (2.4 Km/Hr)	No. of Blades.....	2
Tires.....	Front: 11 x 5.00 x 5.00	Cutting height range.....	1" to 3" (2.5 cm to 7.5 cm)
	Rear: 16 x 6.50 x 8	Weight.....	360 lbs (163 Kilos)

ASSEMBLY

Hitch Assembly

1. Cut the ties holding the hitch to the ignition key (No hitch on Model 13000). Secure the hitch (A, Fig. 1) to the rear of the frame with two 1/2-13 x 1 hex screws, lock washers and hex nuts (B). Install the washers and nuts on the inside of the frame.

Column Support Assembly

1. Remove the three bolts (C, Fig. 2) from the bottom of the column support.

2. Secure the column support to the forward end of the frame with bolts removed in Step 1.

NOTE: The column support shown in Fig. 2 is one of two different supports. Your unit may have a different style of column support.

3. Attach the rod end assembly (D, Fig. 2) on the bottom of the steering column to the tie rod (E) as follows:

A. Remove the top cotter pin (F) and all but one flat washer from the tie rod.

B. Place the rod end assembly (D) over the tie rod.

C. Re-install the remaining flat washers (G). Re-install the cotter pin.

Battery

1. Lift seat support and disconnect first the negative (-) and then the positive (+) cables from the battery terminals.

3. Remove two lock nuts and washers from the two "L" bolts and remove battery.

4. Fill battery with electrolyte to the level indicated on the battery case.

5. Charge battery using a trickle type charger. If a trickle type charger is not available, have the battery initially charged at an

outdoor power equipment shop, battery store or service station. **DO NOT USE AN AUTOMOTIVE-TYPE BATTERY CHARGER OR ELSE THE BATTERY COULD BE DAMAGED!**

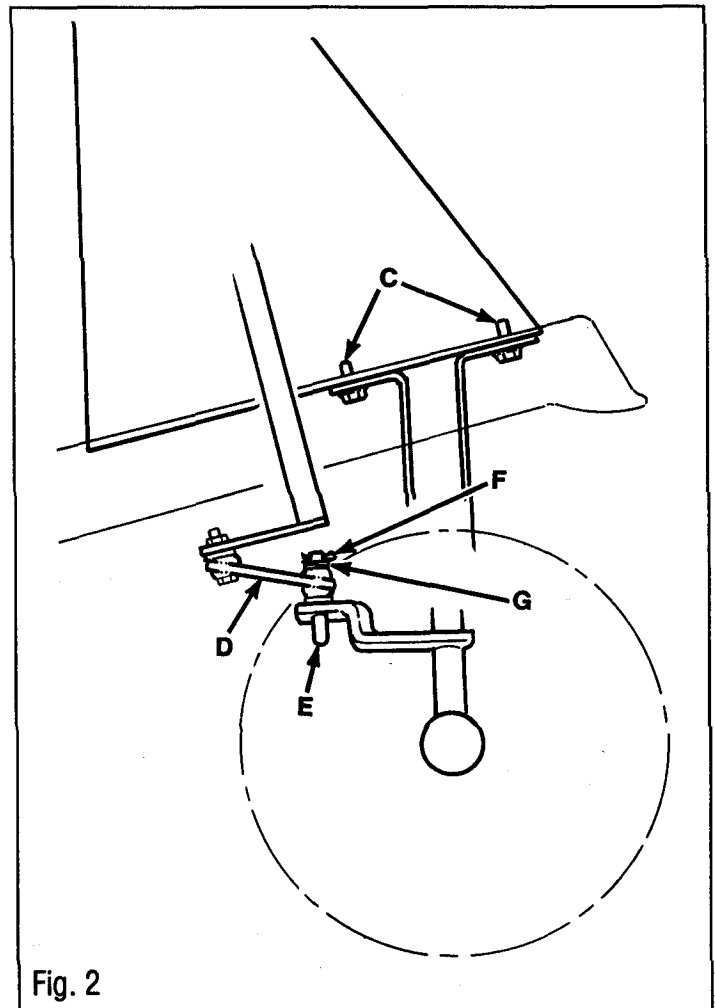
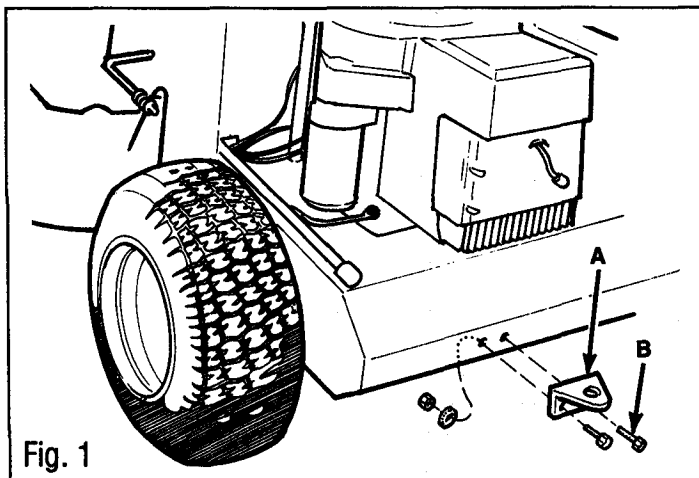

ASSEMBLY (Cont.)

6. Re-install battery after servicing, with negative (-) terminal to the left. Re-install battery hold-down clamps and secure. It may be necessary to hold "L"-Bolts up against the underside of frame, so nuts can be threaded onto the tops of the "L"-bolts.



WARNING!

BATTERY ELECTROLYTE CAN CAUSE SEVERE BURNS AND BLINDNESS.

WEAR EYE PROTECTION AND PROTECTIVE CLOTHING WHEN WORKING NEAR A BATTERY.

FAILURE TO FOLLOW THIS INSTRUCTION COULD RESULT IN PERSONAL INJURY OR PROPERTY DAMAGE.

IN THE EVENT OF AN ACCIDENT, FLUSH WITH WATER AND CALL A PHYSICIAN IMMEDIATELY.

7. Re-connect first the positive (+) cable to the positive (+) battery terminal and then the negative (-) cable to the negative (-) battery terminal.

Seat Assembly

1. Locate wiring harness (F, Fig. 3) under seat support and connect to seat interlock switch (G).

2. Attach front of seat to seat support using two shoulder bolts (H), nylon washer (I) and wave washer (J). Position nylon washer between wave washer and seat support. Add one 1-1/4" steel washer (K) between seat and seat support on each bolt (H). Secure rear of seat with two flat washers and hand knobs (L).

Seat Adjustment

The seat can be adjusted forward and backward by loosening hand knobs (L). Re-tighten after seat is in desired position.

Engine Oil

Refer to the Engine Owner's Manual supplied for engine oil specifications.

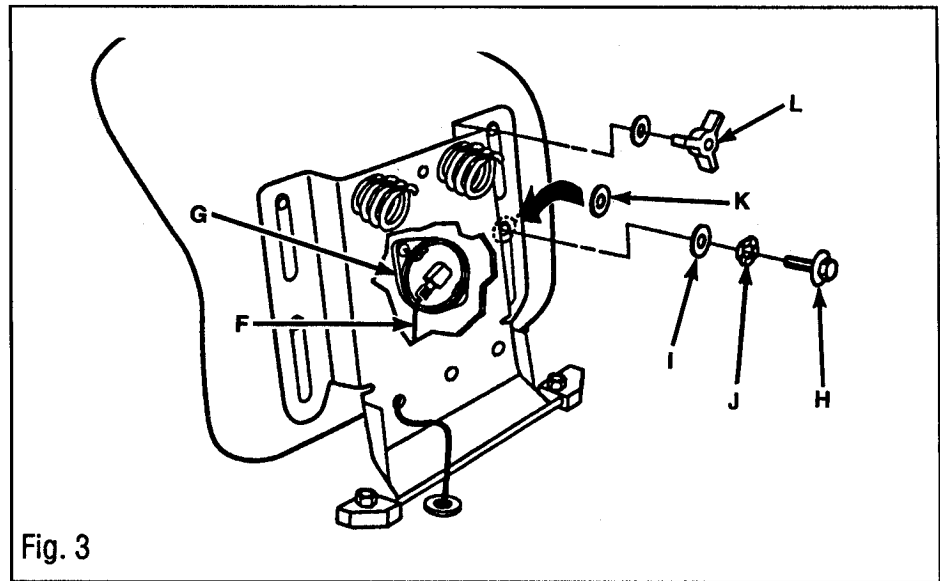

Fig. 3



WARNING!

YOUR UNIT HAS BEEN SHIPPED WITHOUT OIL IN THE ENGINE. DO NOT START THE ENGINE WITHOUT FIRST CHECKING THE ENGINE OIL LEVEL. THE ENGINE WILL BE SEVERELY DAMAGED IF IT IS STARTED WITHOUT OIL IN THE CRANKCASE.

Spark Plug

Unplug spark plug wire from spark plug and keep wire well away from plug until you are ready to use your riding mower. This will help prevent accidental starting.

WHEEL ASSEMBLY (if required)

Rear Wheels

1. Grease axle (Never Seize).
2. Place spacer (Z, Fig. 4) onto each side of rear axle.
3. Place two 1-1/4" flat washers (Y) on each side of rear axle and install wheels.
5. **RIGHT SIDE OF AXLE:** Place two 1-1/4" washers (P) and second spacer (Z) on right axle. Place two 1-1/2" shim washers (X) on the right axle and secure with retaining ring (W).

5. **LEFT SIDE OF AXLE:** Place two 1-1/4" washers (P) and second spacer (Z) on left axle. Add two or three 1-1/2" shim washers (X) on the axle as required. Place spacer and shims to eliminate play without restricting wheel movement. Secure with retaining ring (V).

7. Attach protector caps (V) to both sides of axle.

Front Wheels

1. Place one 1-1/4" washer (Q) and two 1-3/8" washers (S) onto front axle. Place wheel on front axle.
3. Place two 1-3/8" washers (U) on axle as required to eliminate free play without restricting movement.
4. Secure wheel & washers with retaining ring (T).
5. Attach protector caps (R) to both sides of axle.

ASSEMBLY (Cont.)

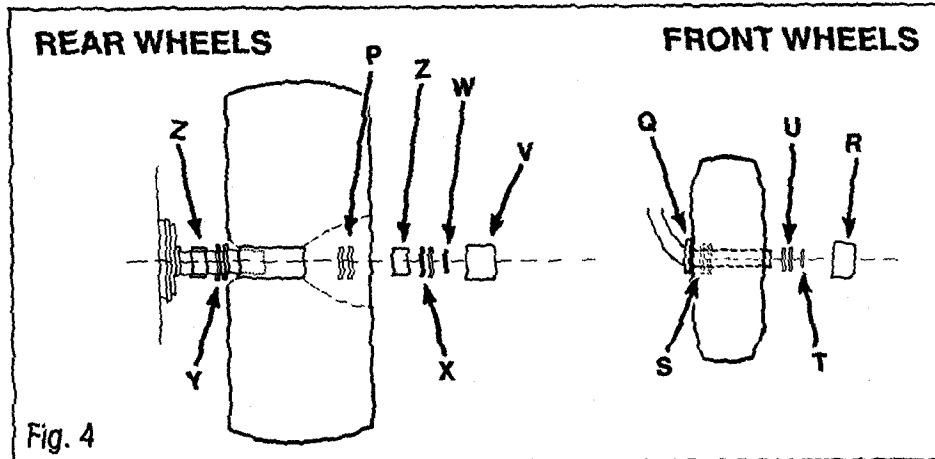

Fig. 4

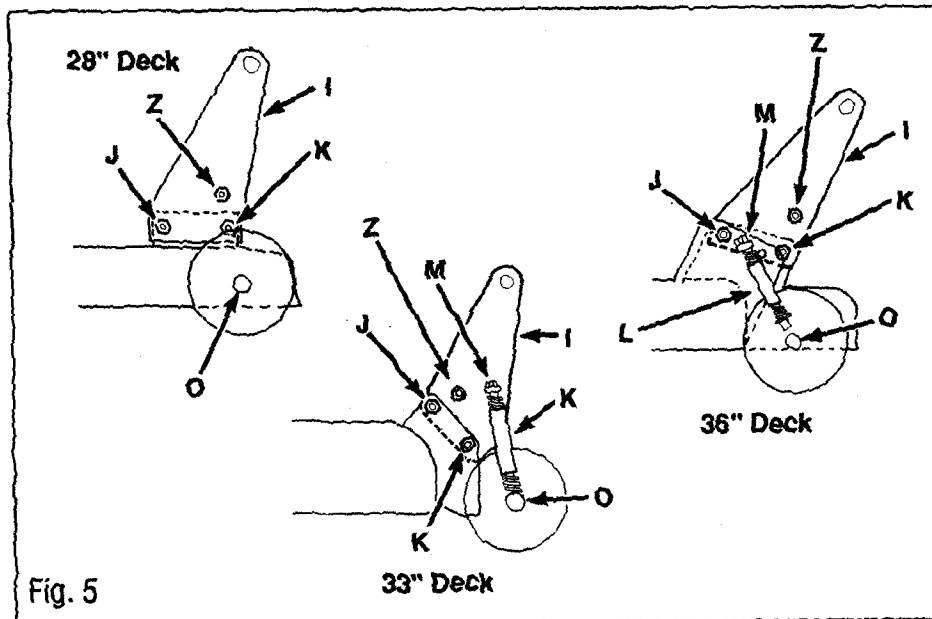

Fig. 5

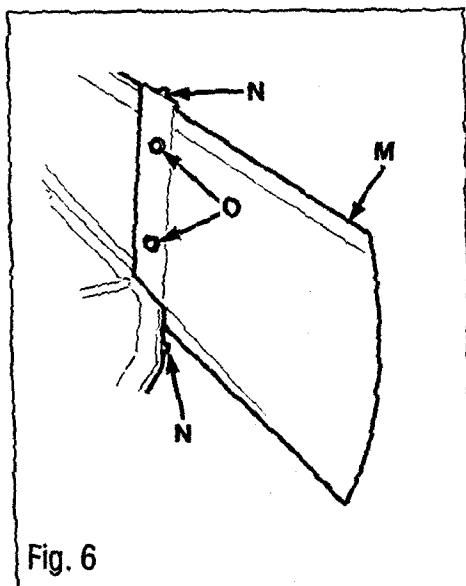

Fig. 6

MOWER DECK LIFT PLATE ASSEMBLY (If required)

- 33" DECKS:** Place lift plate (I) on *inside* of bracket on mower deck (See Fig. 5).
- 28" & 36" DECKS:** Place lift plate (I) on *inside* of bracket on mower deck (See Fig. 5).
- 28" & 36" DECKS:** Place pivot (M) into desired height setting hole in lift plate (I) and secure with washer and spring pin. See **GAGE WHEEL ADJUSTMENT** to determine proper height.

- Attach shoulder bolts (Z) to lift plates. Insert bolt from the inside. Secure with nut.

GAGE WHEEL ASSEMBLY (If required)

- Slide a spacer, a gage wheel, and a 1/2 flat washer onto a gage wheel axle. Secure with a cotter pin. Repeat on the other side.

MOWER DECK INSTALLATION

28" Mower Deck Installation

The 28" mower deck is shipped assembled on your riding mower, with the discharge chute removed (this discharge chute **MUST** be installed on the deck before using the mower). Some adjustment of the mower deck may also be required (See page 14).



WARNING!

TO HELP PREVENT PERSONAL INJURY FROM OBJECTS THROWN BY THE MOWER DECK BLADE, THE DISCHARGE CHUTE MUST BE INSTALLED ON THE DECK.

FAILURE TO FOLLOW THIS INSTRUCTION COULD RESULT IN PERSONAL INJURY OR PROPERTY DAMAGE.

NOTE: FOR SHIPPING PURPOSES ONLY, A TEMPORARY SHIELD HAS BEEN INSTALLED IN THE DISCHARGE OPENING ON THE MOWER DECK.

- Remove bolts holding temporary shield in discharge opening. Remove shield and discard.
- Loosely attach ends of discharge chute (M, Fig. 6) inside discharge opening with two 5/16-18 x 3/4 flange screws and 5/16-18 flange nuts (N). The nuts should be on top.

ASSEMBLY (Cont.)

3. Loosely attach top of discharge chute with two 5/16-18 x 3/4 carriage bolts and two 5/16-18 flange nuts (O). The nuts should be to the outside.

4. Tighten all four nuts and bolts installed in Steps 2 and 3.

33" & 36" Inch Mower Deck Installation

1. Lift tractor up and slide mower deck under tractor with gage wheels toward the rear.

2. Connect lift rods (D, Fig. 7) to mower decks and secure with spring pins (L).

3. Connect pivot rods (E, Fig. 7) to lift plates (F) on mower deck. Secure with spring pins (X).

4. Connect front of rod end (U, Fig. 6) to tractor and secure with clevis pin (V) and spring pin (W).

5. Remove belt guide (P, Fig. 7).

6. Route mower drive belt over sheave (Y). It may be necessary to rotate differential to assemble belt.

7. Re-install belt guide (P) as far to the front as possible. Re-tighten belt guide. Check clearance between guide (P) and bolt head on differential. A 1/8" minimum gap should exist.

8. Install mower blade drive cable (S, Figs. 8, 9 & 10) from tractor, onto cable support (Q), as shown in Figs. 8, 9 & 10.

9. With the mower blade drive lever (F, page 17, Fig. 23) in the disengaged (DOWN) position. Adjust nuts (R, Fig. 10) so all slack has been taken up in cable (S). Tighten nuts (R).

36" Discharge Chute Assembly

1. Secure discharge chute (T, Fig. 11) over discharge opening with two 3/8-16 x 3/4 carriage bolts and 3/8-16 top lock nuts (N). Install so the nuts are on top.

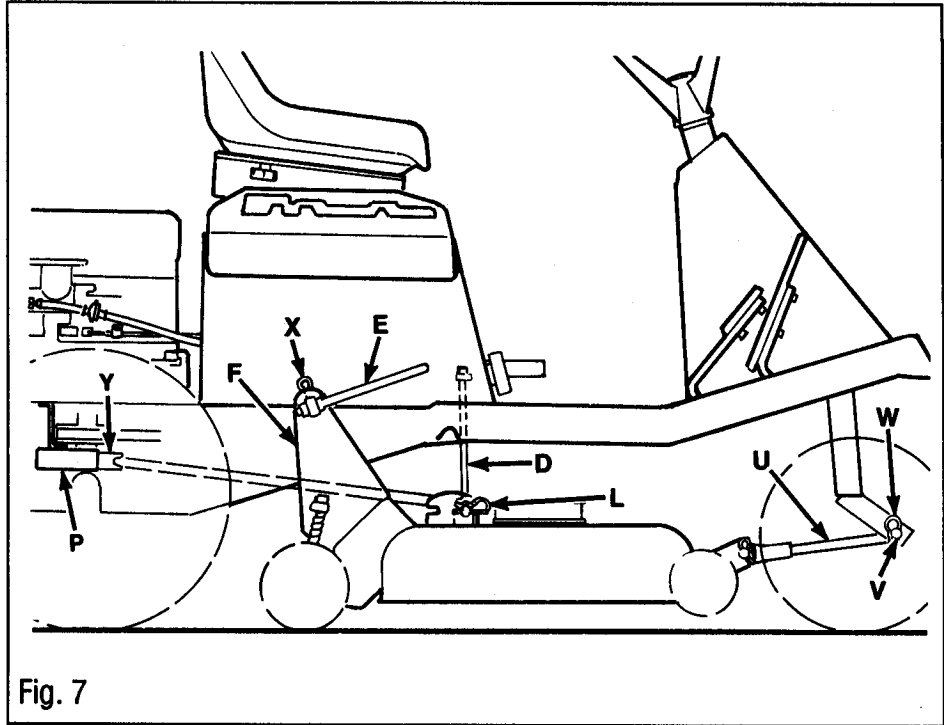

Fig. 7

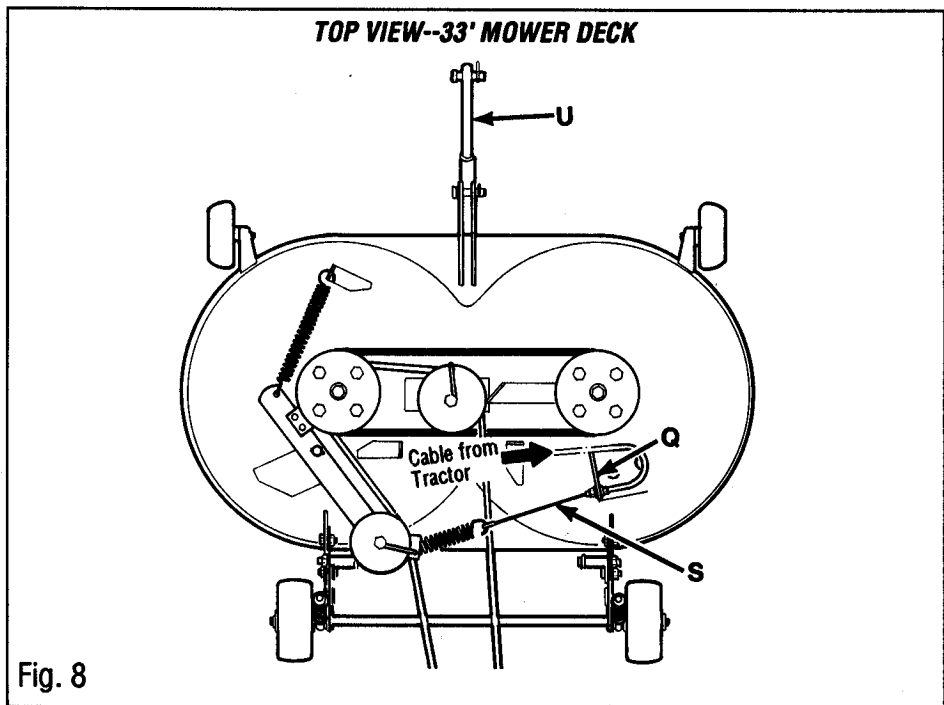
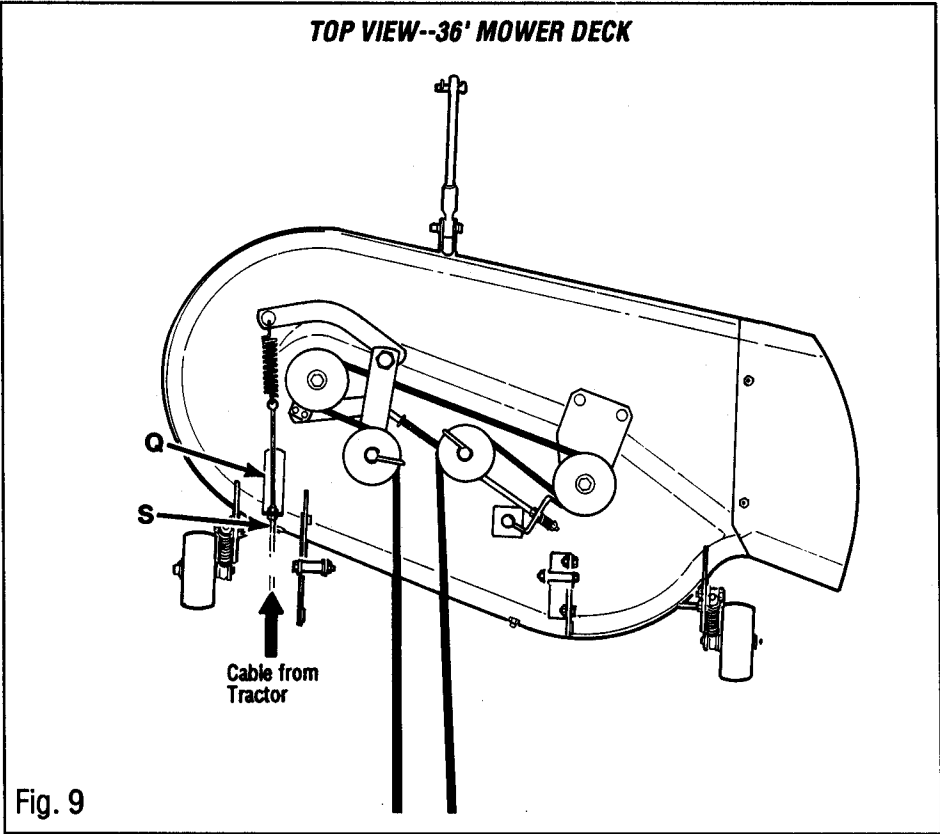

Fig. 8

ASSEMBLY (Cont.)



WARNING!

TO HELP PREVENT PERSONAL INJURY FROM OBJECTS THROWN BY THE MOWER DECK BLADE, THE DISCHARGE CHUTE MUST BE INSTALLED ON THE DECK.

FAILURE TO FOLLOW THIS INSTRUCTION COULD RESULT IN PERSONAL INJURY OR PROPERTY DAMAGE.

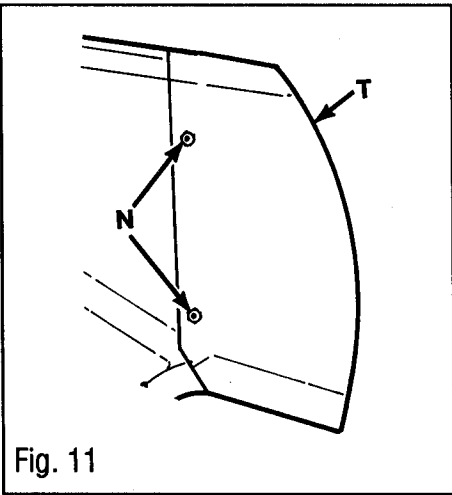
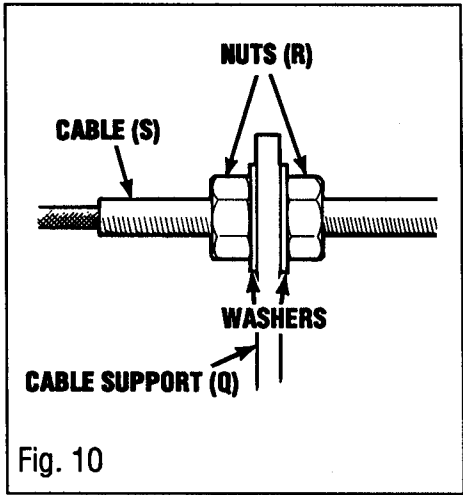

ASSEMBLY (Cont.)

RIDER PREPARATION FOR DIFFERENT SIZED DECKS

28" and 36" decks require a different set-up of the riding mower than the 33" deck. Set-up for the two configurations is described below.

Remove Seat Support Cover

1. Lift seat.
2. Unscrew and remove shift knob.
3. Remove screws (B, Fig. 12) and remove shift quadrant.
4. Unplug seat switch.
5. Remove screws (U) and pull seat support from seat support cover.
6. Remove remaining 3 screws (A) securing seat support cover. Remove 2 screws (C) securing gas tank to seat support cover. Remove seat support cover.

Install Mower Blade Drive Cable

1. Thread nut (D, Fig. 13) downward on cable threads until it stops.
2. Thread nut (H) and washer (I) upward and off cable assembly.
3. **28" & 36" DECKS ONLY:** Insert cable, nut (H) and washer (I) upward through rear slot (E) in frame.
3. **33" DECKS ONLY:** Insert cable, nut (H) and washer (I) upward through front slot (F) in frame.
4. Place nut (H) and washer (I) at top of slot and screw down tightly, securing cable assembly to frame.
5. Connect cable to the mower blade drive (PTO) lever (G). Fasten cable to the right side of PTO lever when facing toward front of rider. Secure with screw (J) and nut as shown in Fig. 13. Tighten screw, but allow some play so cable may pivot.

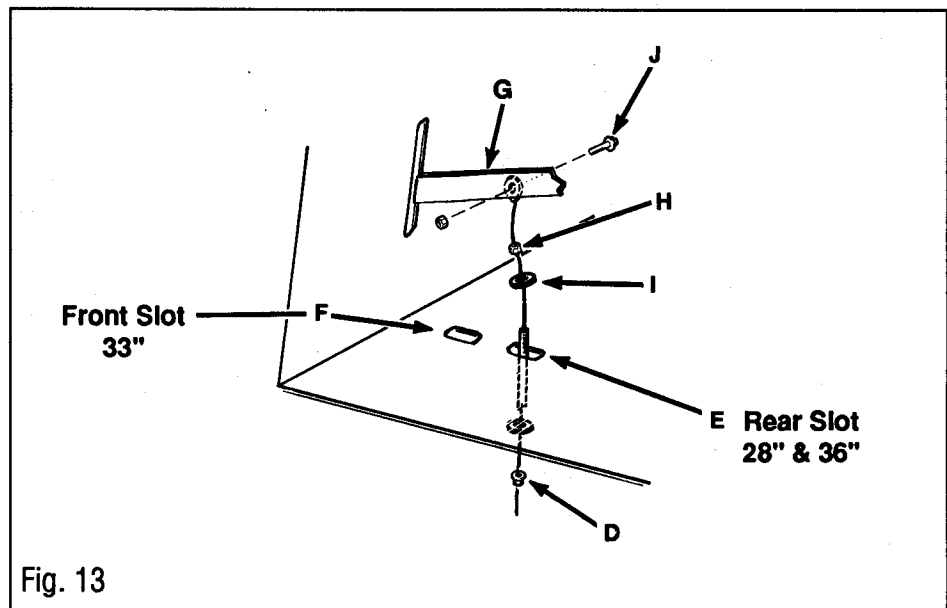
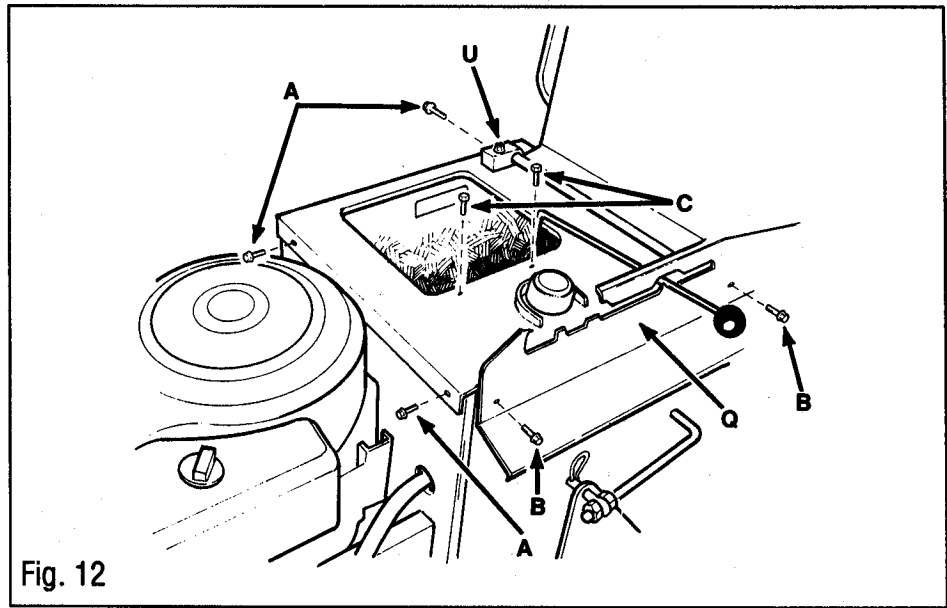

Connect (Left Side) Link to Lift Assembly

28" & 36" Decks Only

1. If swivel (J, Fig. 14) is not attached to OUTER lift arm, remove hair pin and washer. Attach swivel to the OUTER lift arm. Swivel loop should face to the outside (left), over the OUTER slot. Place

washer and attach hair pin. Hair pin should be on the inside (right) of lift arm.

2. Slide link (K) upward, through the OUTER slot on the frame. Slide link through swivel (J). Thread nut (L) onto link. The position of the nut will determine the height of the mower when set in transport position. See instructions in the *DECK ADJUSTMENTS*, on page 14.

ASSEMBLY (Cont.)

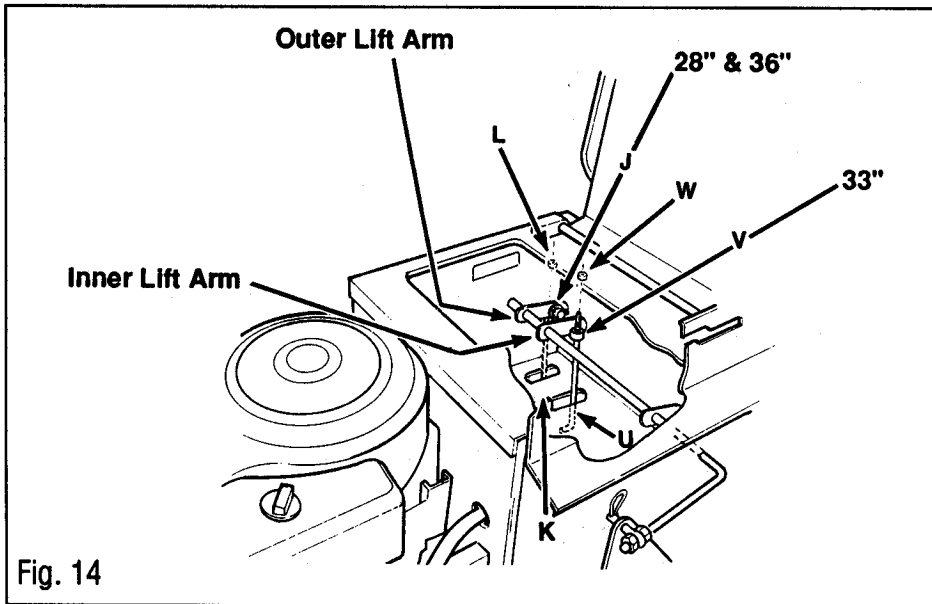

3. To install mower deck, See the *DECK INSTALLATION* on page 9.

33" Decks Only

1. If swivel (V, Fig. 14) is not attached to INNER lift arm, remove hair pin and washer. Attach swivel to the INNER lift arm. Swivel loop should face to the inside (right), over the INNER slot. Place washer and attach hair pin. Hair pin should be on the outside (left) of lift arm.
2. Slide link (U) upward, through the INNER slot on the frame. Slide link through swivel (V). Thread nut (W) onto link. The position of nut will determine the height of the mower when set in transport positions. See instructions in the *DECK ADJUSTMENTS* on page 14.

Replace Seat, Seat Support Cover and Seat Switch

1. Position seat support cover in position as shown in Fig. 12. Thread 2 screws (C) into gas tank, but do not tighten. Thread screws (A) into the sides of seat support cover. Tighten all hardware.
2. Position seat support on seat support cover as shown in Fig. 12. Secure seat support with screws (U).
3. Plug in seat switch.
4. Position shift quadrant (Q) as shown. Secure with screws (B, Fig. 11).
5. Secure shift knob onto end of shift lever.
6. Lower seat.

Test Interlock System

Before operating unit, perform the interlock system test outlined in the *CONTROLS AND OPERATION* on page 20.



DANGER!

THE SAFETY INTERLOCK SWITCH SHOULD SHUT DOWN THE ENGINE WITHIN A FEW SECONDS AFTER THE OPERATOR LEAVES THE SEAT. IF THIS SWITCH FAILS TO OPERATE, HAVE THE MOWER SERVICED IMMEDIATELY BY AN AUTHORIZED BOLENS® DEALER. SEVERE INJURY COULD RESULT FROM NOT FOLLOWING THIS INSTRUCTION.

ASSEMBLY (Cont.)

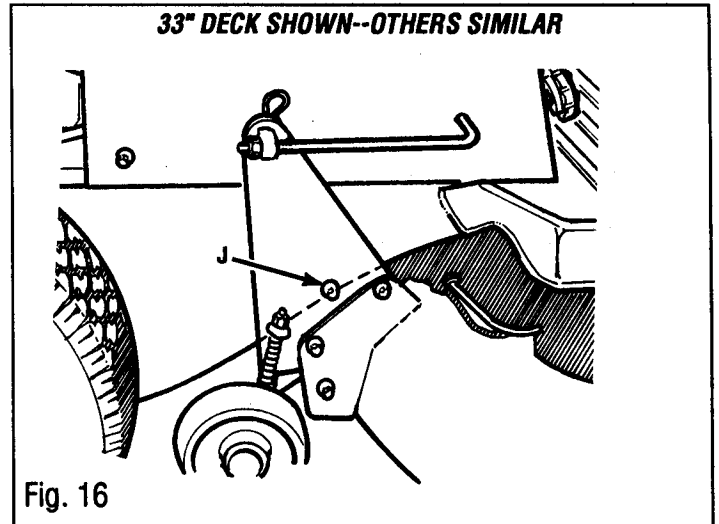
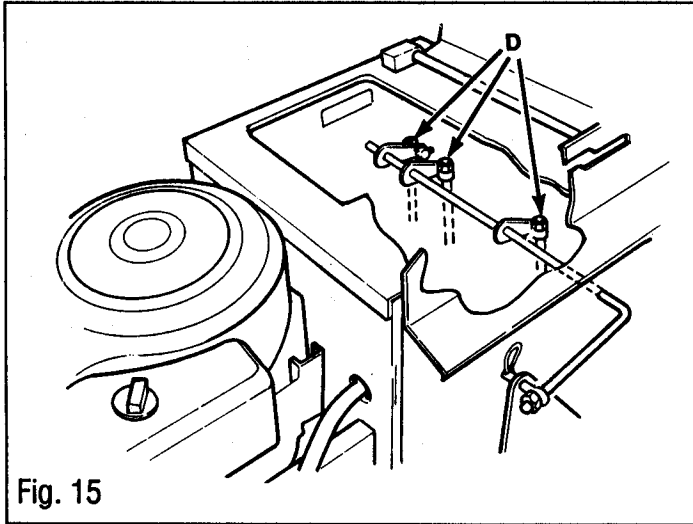

DECK ADJUSTMENTS

All mower decks should be checked and re-adjusted, if necessary, before using the riding mower.

36" decks should be checked after assembly and installation for proper adjustment.

All Decks—Transport Height Adjustment

A 1/2" socket wrench with an extension and a universal joint is recommended for this adjustment. When mower lift lever (See page 18, Item I) is in the raised (UP) position, there should be a gap of no more than 1/8" between shoulder bolts (J, Fig. 16) on the mower deck lifting plates and frame. If adjustment is necessary, lift seat and seat support. Remove lift rod from mower deck and push lift rod up through frame so nuts (D, Fig. 15) are accessible. Turn nuts (D) with the socket wrench, re-attach mower deck, and check. Repeat as necessary.

28" Decks—Mower Drive Belt Tension Adjustment

Check distance (K, Fig. 17), between center of pivot block and center of pivot. Normal distance should be 7-1/2" (7-1/4" for 36" Decks). *NOTE: AFTER THE MOWER HAS BEEN USED FOR A WHILE, THE MOWER DRIVE BELT CAN STRETCH AND BEGIN*

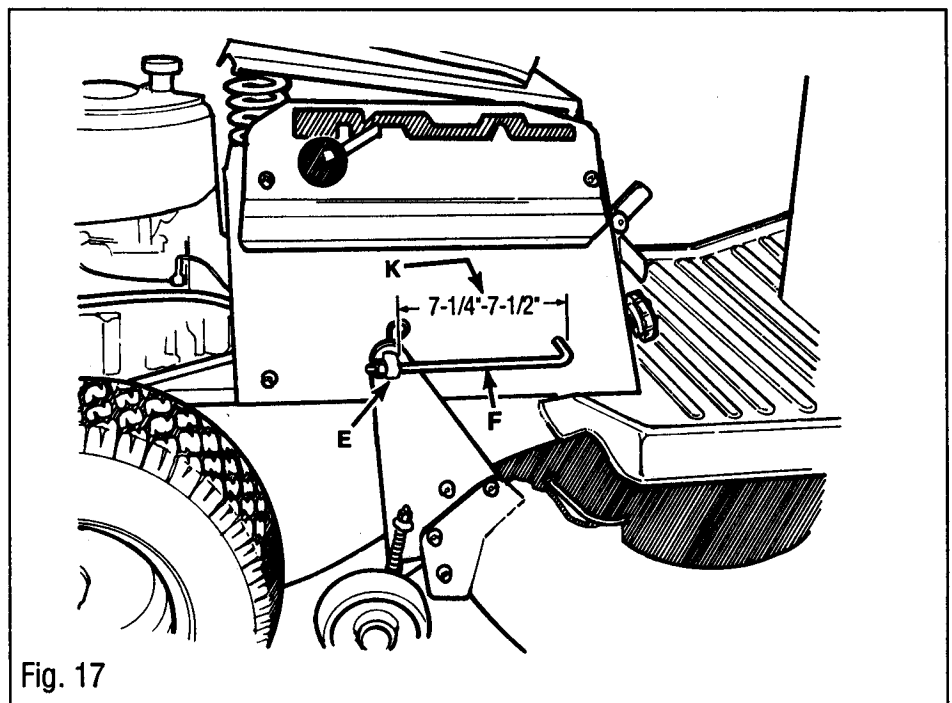

SLIPPING. MOVE DECK FORWARD BY ROTATING PIVOT (E) TO THE REAR ON RODS (F) TO PROVIDE ADDED BELT TENSION. RE-ADJUST FRONT LINK TO LEVEL MOWER.

(SEE PAGE 25, MOWER DRIVE BELT REPLACEMENT FOR ADDITIONAL DRIVE BELT ADJUSTMENT INFORMATION).

33" & 36" Decks—Mower Drive Belt Tension Adjustment

Belt tension is controlled by position of idler (M, Figs. 19 & 21) and pivot rods (F, Fig. 17). Distance (K, Fig. 17) should be 7-1/2" for 33" decks 7-1/4" for 36" decks. Adjust position of idler (M, Figs. 19 & 21) by moving it along the slot. If further adjustment is necessary, adjust distance (K, Fig. 17) by rotating pivot (E) to the rear. Re-adjust front center link to level mower. *NOTE: AFTER THE MOWER HAS*

ASSEMBLY (Cont.)

BEEN USED FOR A WHILE, THE MOWER DRIVE BELT CAN STRETCH AND BEGIN SLIPPING. MOVE DECK FORWARD BY RELOCATING PIVOT (E) ON PIVOT RODS (F) TO ADD BELT TENSION. RE-ADJUST FRONT CENTER LINK TO LEVEL MOWER.

(SEE PAGE 25, MOWER DRIVE BELT REPLACEMENT FOR ADDITIONAL DRIVE BELT ADJUSTMENT INFORMATION).

28" & 36" Decks—Mower Spring Connection Adjustment

With mower lift lever (See page 18, Item 1) in the disengaged position, adjust cable (S, Figs. 18, 20, & 21) at nuts (R, Fig. 20) until all slack in cable has been taken up. WHEN ADJUSTED, SPRING (T) SHOULD NOT BE UNDER TENSION.

33" Decks—Mower Spring Connection Adjustment

With mower lift lever (See page 18, Item 1) in the disengaged position, adjust cable (S, Figs. 19 & 21) at nuts (R, Fig. 21) so there is a slight slack in cable. WHEN ADJUSTED, SPRING (T) SHOULD NOT BE UNDER TENSION.

MOWER DECK LEVELING

Park the riding mower on a hard, level surface.

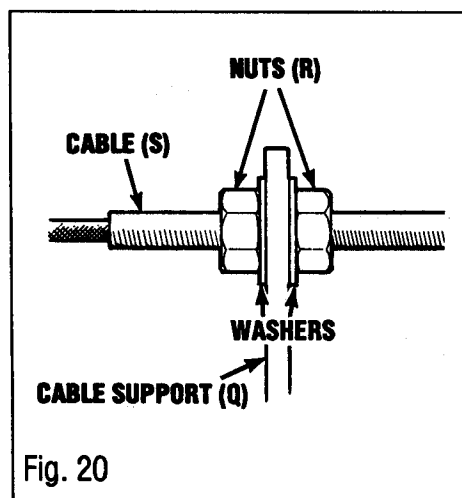
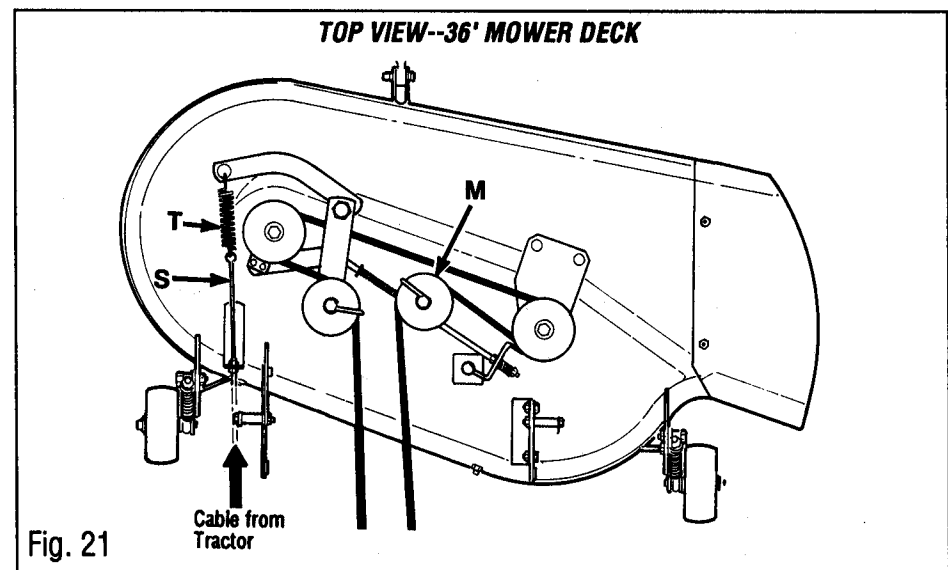
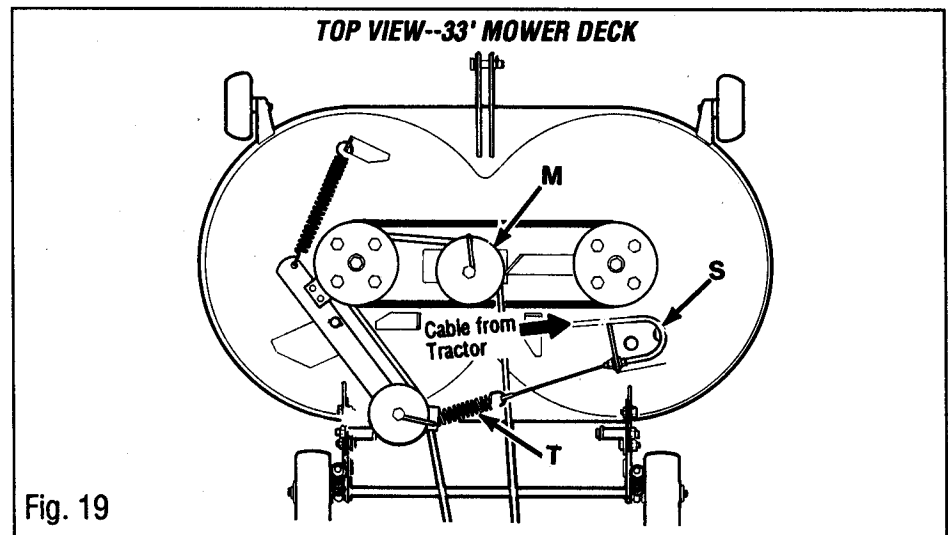
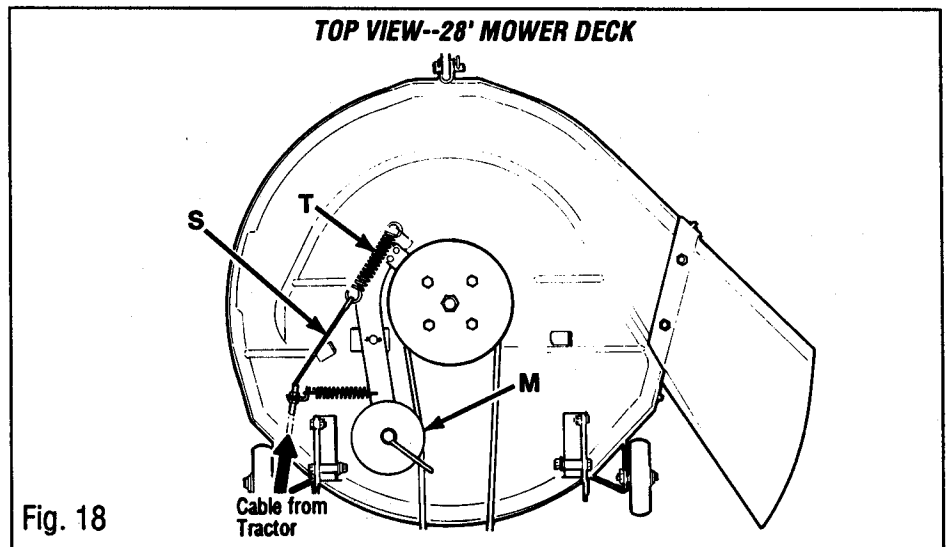

ASSEMBLY (Cont.)

Tire Pressure

1. Use an automotive-type tire gauge to check the air pressure in all four tires.

Front tiresfrom 12 to 15 PSI (82 to 103 kPa) equally inflated.

Rear tiresfrom 8 to 10 PSI (55 to 68 kPa) equally inflated.

DO NOT OVER-INFLATE.

Front to Rear Leveling

1. Check tire pressure as explained above.
2. Place mower lift lever (I, page 18) to the lower (DOWN) position so deck is in cutting position.
3. Adjust mower height adjusting knob (G, Fig. 23) so the mower blades are approximately 2-1/2" from the ground.
4. Align a cutting blade so tips point to the front and rear of the unit. Measure distance from ground to tips of blade. (R, Fig. 22). Both tips should be the same distance from the ground. If they are not, adjust front rod (A, Fig. 22) as necessary. Place mower lift lever into the raised (UP) position to adjust. Lower mower again to recheck level.

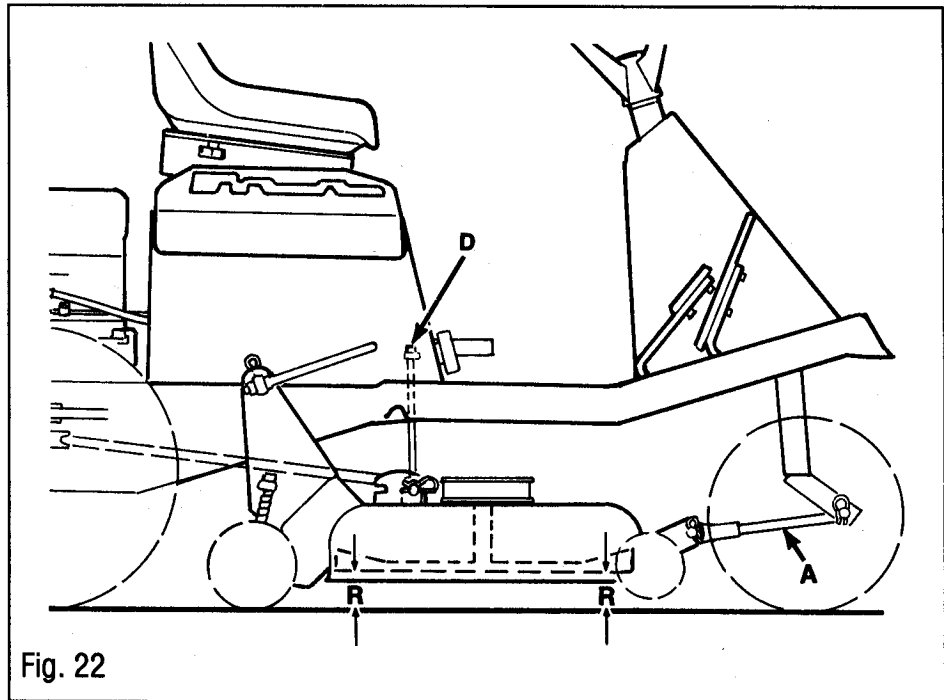

Fig. 22

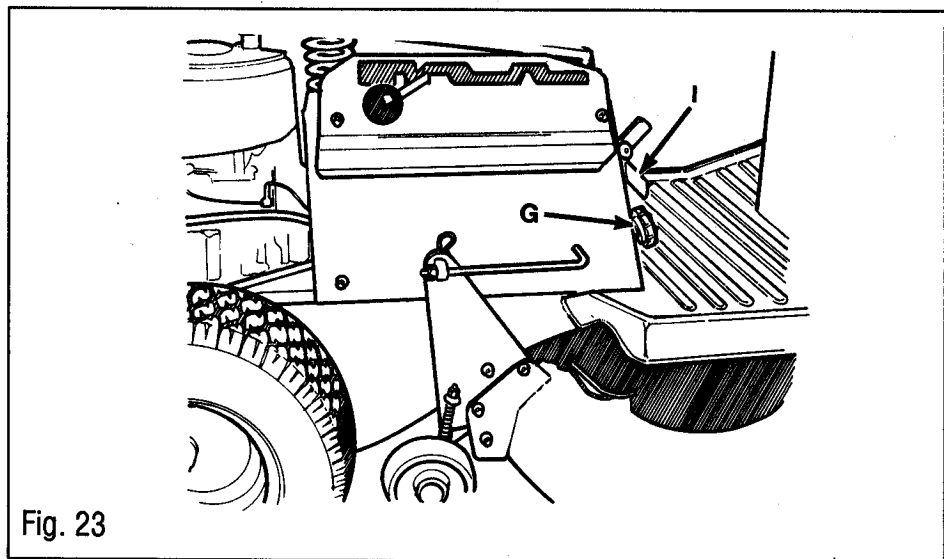

Fig. 23

Side to Side Leveling

1. Align a cutting blade so tips point from side to side of the unit.
2. Measure distance from ground to tips of blade. Both tips should be the same distance from the ground. If they are not, remove lift rod from mower deck and push lift rod up through frame so nuts (D, Fig. 22) are accessible. Adjust nuts (D) as necessary. Re-attach lift rods and re-check level. Repeat as necessary.

Other Deck Information

Additional mower deck information can be found in *MOWER DECK MAINTENANCE*, beginning on page 25.

CONTROLS AND OPERATION

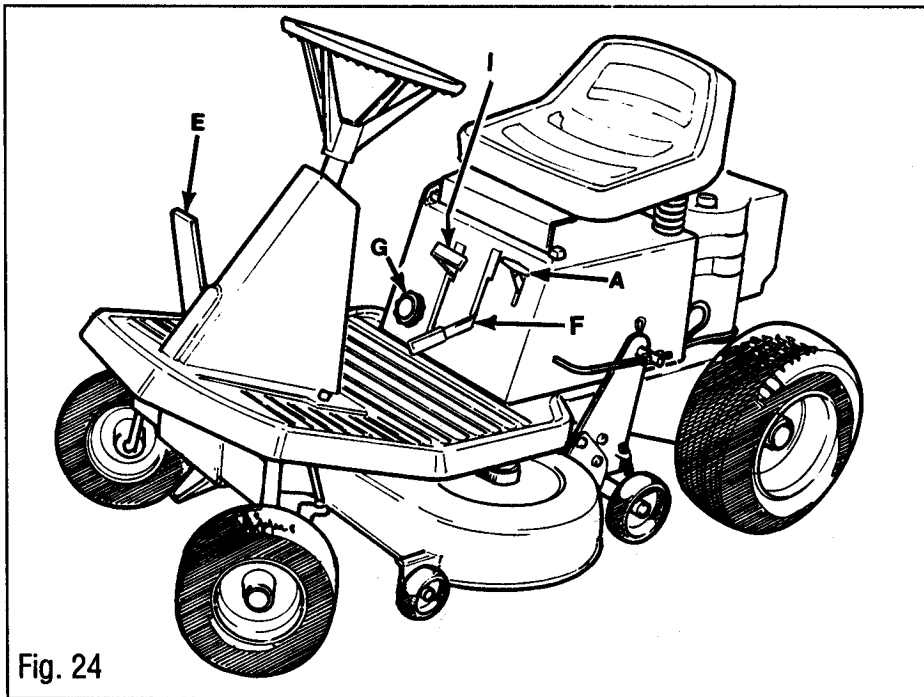

Fig. 24

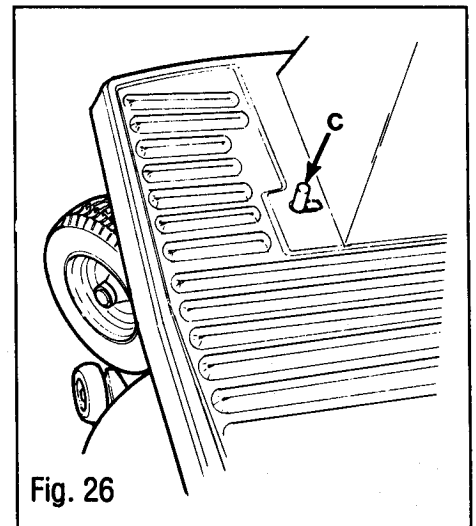

Fig. 26

way up places the engine in CHOKE. For best performance, always run the engine at full throttle. USE CHOKE POSITION FOR STARTING ONLY.

B — BRAKE PEDAL. Stops the forward or rearward motion of the mower. IT DOES NOT STOP THE ROTATION OF THE MOWER BLADES.

C — PARKING BRAKE (BRAKE LOCK). Push the brake pedal (B) all the way down and push brake lock (C, Fig. 26) to the right to apply the parking brake. To disengage, push the brake pedal down and release.

D — IGNITION KEYSWITCH. The keyswitch has three positions — OFF, RUN, and START.

E — DRIVE PEDAL. Engages the forward or rearward motion of the riding mower.

F — MOWER BLADE DRIVE LEVER. Engages drive to the mower deck blade(s). To engage, lift lever and move it to the left into the detent. To disengage, lift lever, push it to the right, and slowly release. **NOTE: DISENGAGE MOWER BLADE DRIVE WHENEVER THE CUTTING BLADES ARE NOT IN USE.**

G — MOWER HEIGHT ADJUSTING KNOB. This knob allows you to select infinitely variable cutting heights for the mower deck. Twisting clockwise raises mower, counter-clockwise lowers mower.

H — TRANSMISSION SHIFT LEVER. Allows you to select either reverse,

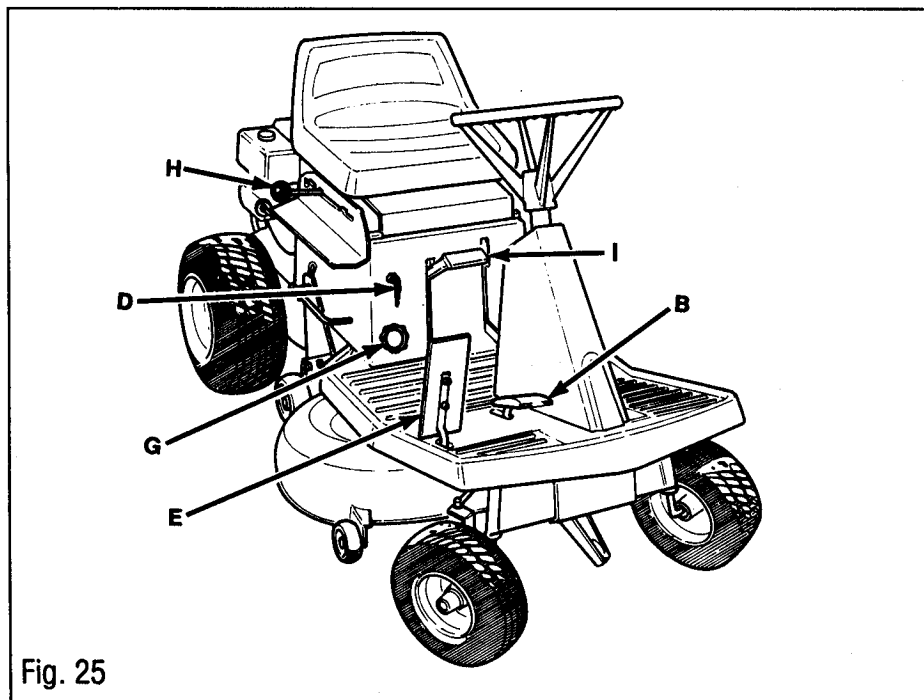

Fig. 25

CONTROLS

Know the riding mower before you operate it. Carefully review this manual and become thoroughly familiar with the operating procedures and safety precautions.

Figures 24, 25, 26, 27 & 28 show you the location of all primary controls on your riding mower. See below for descriptions.

A — ENGINE SPEED LEVER. Controls the engine speed. Down decreases engine speed, up increases engine speed, all the

CONTROLS AND OPERATION (Cont.)

neutral, or one of five forward gears. (See SPECIFICATIONS on page 6 for average speeds in some of these gears). Until you become familiar with the riding mower, use only the lower gears — either 1, 2, or 3. See Fig. 27 for detailed shifting pattern.

1 — MOWER LIFT LEVER. (Fig. 28) While in the UP position, the mower deck is in transport position. In the DOWN position, the mower deck is in the mowing position. The Mower Lift Lever should be in the UP position whenever the riding mower is not actually mowing.

NOTE: THIS RIDING MOWER HAS INTERLOCK SWITCHES AT THE BRAKE, MOWER CLUTCH, AND SEAT. THE UNIT WILL NOT START UNLESS THE BRAKE PEDAL IS DEPRESSED (OR THE PARKING BRAKE IS SET), AND THE MOWER BLADE DRIVE LEVER IS IN THE DISENGAGED POSITION.

THE ENGINE WILL AUTOMATICALLY STOP IF THE OPERATOR LEAVES THE SEAT WHEN EITHER THE MOWER BLADE IS ENGAGED OR THE BRAKE PEDAL IS NOT DEPRESSED.



DANGER!

THE SAFETY INTERLOCK SWITCH SHOULD SHUT DOWN THE ENGINE WITHIN A FEW SECONDS AFTER THE OPERATOR LEAVES THE SEAT. IF THIS SWITCH FAILS TO OPERATE, HAVE THE MOWER SERVICED IMMEDIATELY BY AN AUTHORIZED BOLENS® DEALER. SEVERE INJURY COULD RESULT FROM NOT FOLLOWING THIS INSTRUCTION.

OPERATION

Pre-Start Checklist

- 1. Review Section 1: SAFETY.
- 2. Check the engine oil level.
- 3. Fill the fuel tank. (See Filling Fuel Tank, below.)
- 4. Check the unit for any loose or missing hardware. Tighten or replace as necessary.
- 5. Inspect the battery for:
 - a. Proper electrolyte level.
- 6. Clean any debris off engine flywheel screen.
- b. Clean cables and battery terminals.

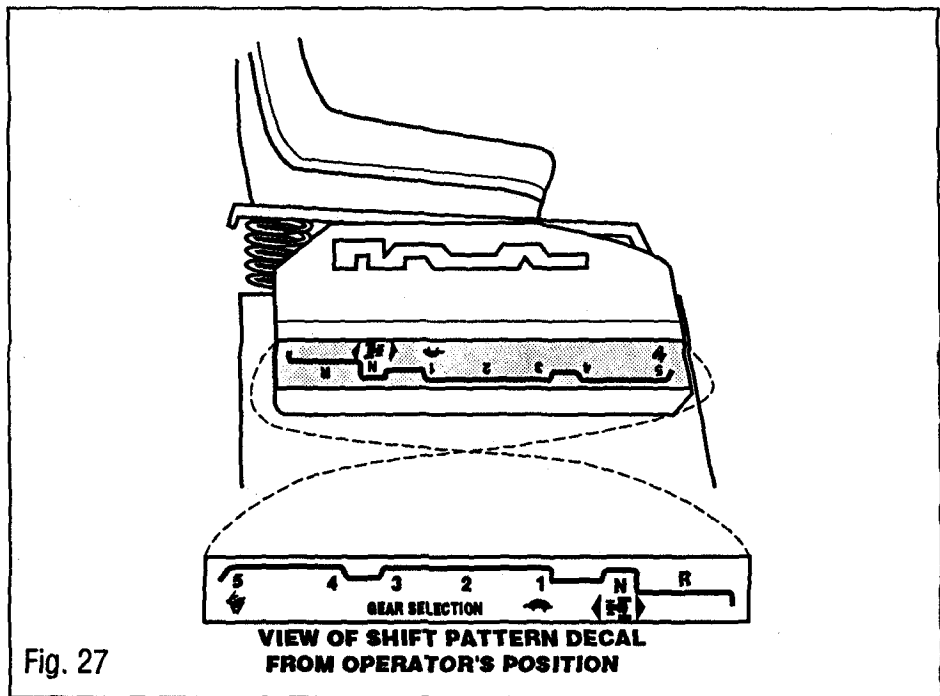

Fig. 27

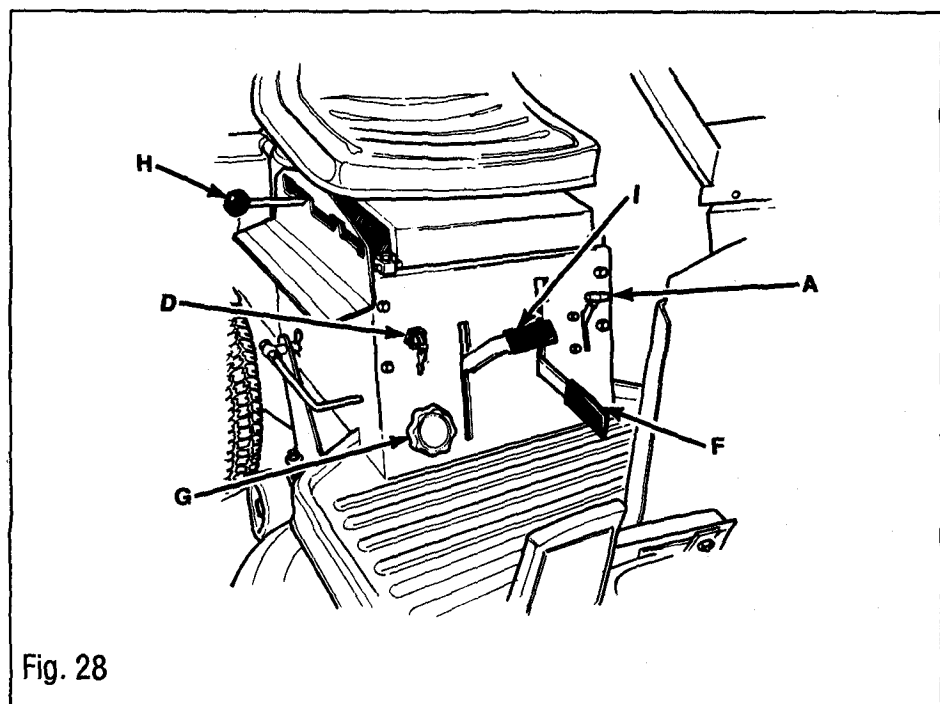

Fig. 28

CONTROLS AND OPERATION (Cont.)

- 7. Check tire inflation:
Front tires: from 12 to 15 PSI (82 to 103 kPa) equally inflated.
Rear tires: from 8 to 10 PSI (55 to 68 kPa) equally inflated.
DO NOT OVER-INFLATE.
- 8. Re-connect spark plug wire to spark plug.
- 9. Make sure mower discharge deflector shield is securely fastened to the right-hand side of mower deck (28 & 36 inch decks).
- 10. Adjust seat to a comfortable position. (See page 8, *Seat Adjustment*.)
- 11. Check area to be mowed. Remove any debris from this area.
- 12. Set parking brake.
- 13. Place transmission shift lever into N (Neutral) (Fig. 27).

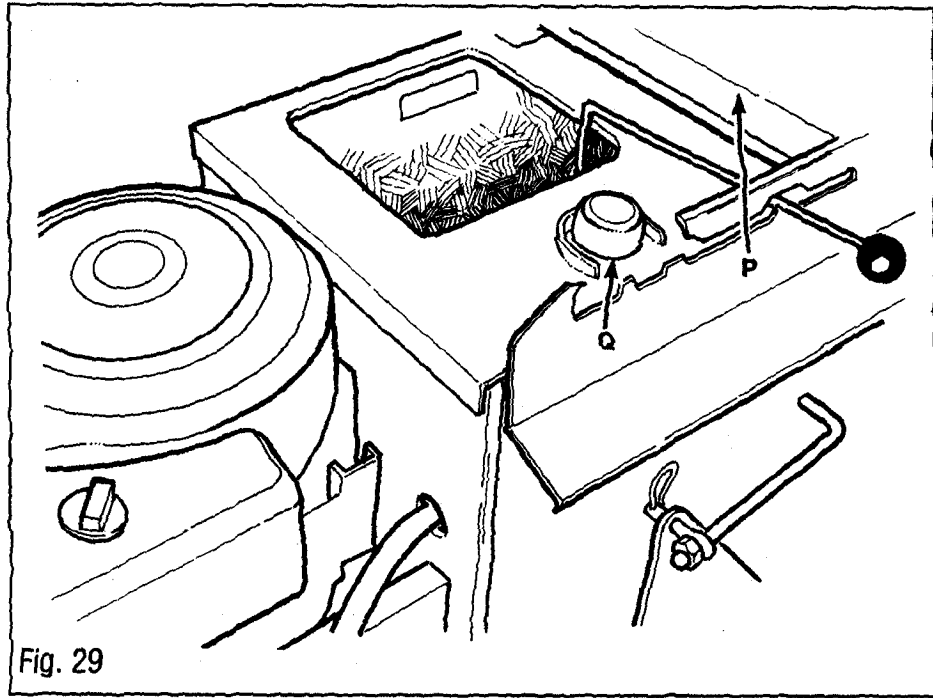

Fig. 29

Filling Fuel Tank

1. Disengage mower blade drive.
2. Shut off engine
3. Set parking brake.
3. Allow engine to cool for at least two minutes before filling fuel tank.
4. Move transmission shift lever into 4th or 5th gear to allow access to fuel tank filler cap.
5. Tilt seat and seat support (P, Fig. 29) forward and upward.
6. SLOWLY unscrew fuel tank filler cap (Q).
7. Use a good grade of clean, fresh, unleaded gasoline. SLOWLY pour gas into tank. Use a funnel if necessary (make sure that it is clean). Frequently stop and check the level of fuel in tank while filling.



DANGER!

GASOLINE IS HIGHLY FLAMMABLE AND ITS VAPORS ARE EXPLOSIVE. DO NOT ADD GASOLINE TO THE TANK WHILE THE ENGINE IS RUNNING. IF THE ENGINE HAS BEEN RUNNING, ALLOW IT TO COOL FOR SEVERAL MINUTES.

DO NOT ALLOW OPEN FLAMES, SPARKS, MATCHES, OR SMOKING NEARBY WHEN REFUELLING.

FILL THE GAS TANK OUTDOORS IN A WELL-VENTILATED AREA. WIPE UP ANY SPILLS AND MOVE THE RIDING MOWER AWAY FROM GASOLINE FUMES BEFORE STARTING THE ENGINE.

NEVER BRING A GASOLINE CAN NEAR THE BATTERY POSTS. A SHORT CIRCUIT CAUSED BY TOUCHING THE POSITIVE (+) POST AND ANY METAL COULD CAUSE AN EXPLOSION OF GASOLINE OR BATTERY GASES.

8. Do not completely fill the fuel tank. Allow at least 1/4-inch of space at the top of the tank. This allows for fuel expansion.
9. Re-install fuel tank filler cap and the cap on the fuel container.
10. Wipe up any spilled gasoline.
11. Tilt seat and seat support rearward and downward.

Starting

1. Perform *Pre-Start Checklist* described earlier.
2. Set parking brake (C, Fig. 26, page 17). The engine will not start unless the brake pedal is down.
3. When starting a cold engine, move engine speed lever (A, Fig. 24, page 17) all the way up to the CHOKE position. When starting a warm engine, set throttle at 3/4 full position.
4. Move mower blade drive lever (See F, page 17) all the way down to its disengaged position. (The engine will not start if the mower blade drive is engaged.)
5. Sit in the operator's seat.
6. Move the transmission shift lever (See Fig. 27, page 18) to N (Neutral).
7. Before starting engine, make sure there are no children nearby.

CONTROLS AND OPERATION (Cont.)

8. Place ignition key in keyswitch and turn key to the START position. Release key as soon as the engine starts.

9. To manually start engine: (all models except 13000 [2027])

A. Place ignition key in keyswitch and turn key to the RUN position.

B. Slowly pull recoil starter rope (A, Fig. 31) outward until you feel some resistance from engine compression—then rapidly pull rope outward.

C. Allow starter rope to gradually rewind rope. Do not release rope and allow it to snap back.

D. Repeat Steps 9B and 9C until the engine starts.

10. Move engine speed lever (A, page 17) to the FAST position.

11. Allow engine to warm up for a few minutes before you mow.

Interlock System Test

1. Before working with the riding mower, always perform an operational check of the riding mower's interlock system as follows:

A. Park the unit on a level surface so it does not roll when you release the brake.

B. Sit in operator's seat and start the engine. (See *Starting on the previous page*) Depress brake pedal and check to make sure mower blade drive is disengaged.

C. Release brake. Raise yourself several inches off the seat. The engine should stop. If it does, go on to the next step. If it does not, have the interlock system adjusted or repaired. **DO NOT OPERATE THE UNIT!**

D. Depress brake pedal again. Re-start engine. Raise mower blade drive lever to its engaged position.

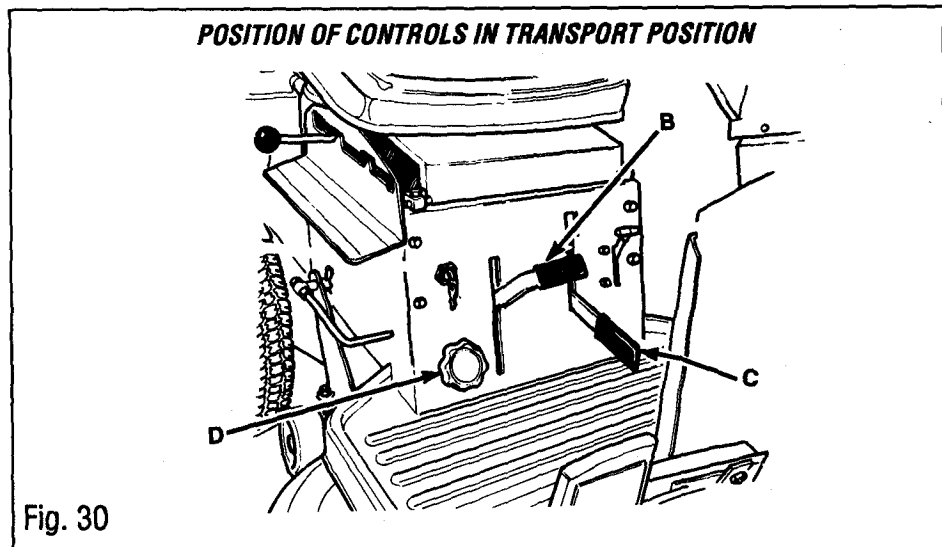

WARNING!

IF THE INTERLOCK SYSTEM DOES NOT FUNCTION PROPERLY, SHUT THE ENGINE OFF, APPLY THE PARKING BRAKE, ALLOW THE ENGINE TO COOL, DISCONNECT THE SPARK PLUG WIRE AND PREVENT IT FROM TOUCHING THE SPARK PLUG, AND REMOVE THE KEY FROM THE KEYSWITCH. DO NOT USE THE RIDING MOWER UNTIL THE INTERLOCK SYSTEM IS REPAIRED.

FAILURE TO FOLLOW THIS WARNING COULD RESULT IN PERSONAL INJURY OR PROPERTY DAMAGE.

E. Again, raise yourself several inches off the seat. The engine should stop. If it does not, have the interlock system adjusted or repaired. **DO NOT OPERATE THE UNIT!**

Mowing

1. After performing the interlock system test on your riding mower, you are now ready to begin actual mowing. Put mower lift lever (B, Fig. 30) up into the raised position, and put the mower blade drive lever (C) down into the disengaged position while transporting your riding mower to the work area.

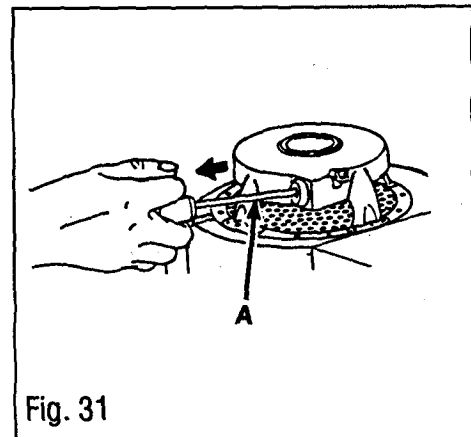

2. Once you have arrived at the work area, release the drive pedal and stop the unit. Make sure the throttle lever is in the FAST position.

3. Select cutting height (See *Testing height of Cut*, next page.)

4. Make sure that no one is in the path of discharge or close to the mower. Slowly engage the mower blade by moving the mower blade drive lever (C, Fig. 32) up to its ENGAGED position.

NOTE: THE MOWER BLADE DRIVE CAN BE DISENGAGED AT ANY TIME BY MOVING THE MOWER BLADE DRIVE LEVER DOWN TO ITS DISENGAGED POSITION.

5. Lower mower lift lever (B, Fig. 32) to the lowest (DOWN) position, to position mower deck for cutting.

6. Select the gear you want by moving the transmission shift lever (Z, Fig. 32) to the

CONTROLS AND OPERATION (Cont.)

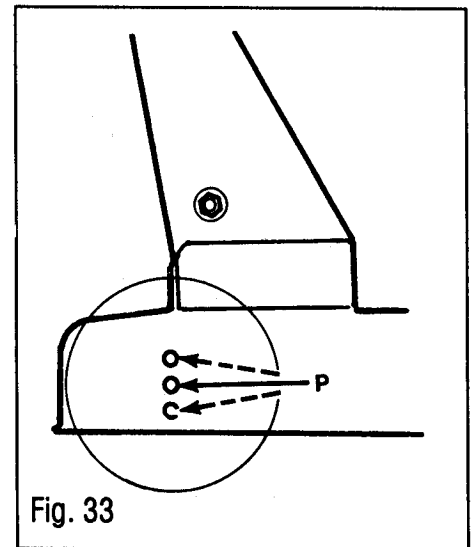
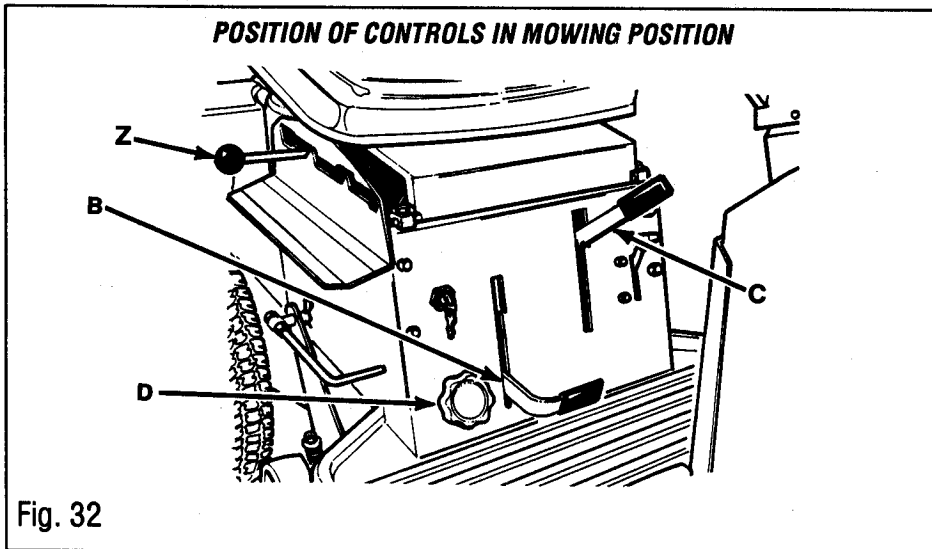

desired gear. Do not mow in R (Reverse). Here are some general gear selection guidelines:

1st gear: Going up or down moderate hills, travelling on slippery surfaces, high grass.

2nd/3rd gear: Level terrain to mild slopes, normal grass.

4th gear: Level terrain, light mowing.

5th gear: Travel from storage site to work location.

Reverse: Moving out of storage site, maneuvering in tight areas.

7. Slowly depress the drive pedal (E, page 17) to begin moving.

NOTE: AFTER YOU BEGIN MOVING, YOU CAN SHIFT TO ANY OF THE HIGHER OR LOWER GEARS "ON THE GO". YOU DO NOT HAVE TO COME TO A COMPLETE STOP — ALL YOU HAVE TO DO IS LET UP ON THE DRIVE PEDAL WHEN YOU SHIFT. HOWEVER, YOU MUST COME TO A COMPLETE STOP WHENEVER YOU SHIFT FROM A FORWARD GEAR TO REVERSE OR FROM REVERSE TO A FORWARD GEAR.

Testing Height of Cut

After mowing a small area, it is recommended that the mower be stopped, the parking brake set, and the height of the cutting area inspected (Make sure there are no small children or inattentive persons around you when this is done). The area can be inspected from the operator's position. If you wish to leave

the operator's position, disengage mower blade drive and stop engine before doing so (See *Stopping*, on next page). Twist the mower height adjusting knob (D, Fig. 32) or clockwise to raise the mower (higher cut), counter-clockwise to lower the mower (shorter cut). A good cutting height to begin with is 2-1/2".

Generally, if the mower is set too low, the grass tends to mat and clump. (This can also happen if the grass is wet. See *Mowing Tips*, on the following page.) If this does happen, raise the mower about 1/4" and test the cut again. Repeat until a clean cut is achieved.

If you have a unit equipped with a 33" mulching deck, cutting height is a very important factor in mulching performance. Set the cutting height high enough so that the deck is not overloaded. Too much grass in the cutting chamber at one time limits the amount of circulation inside the deck and impairs mulching action. An "overloaded" deck will leave grass clumps. Generally, a mulching deck that is set at a slightly higher cutting height will give better performance than one that is set too low. (See also *Mowing Tips*, on the following page.)

GAGE WHEEL ADJUSTMENT

After proper cutting height has been set, the mower deck gage wheels should be adjusted as well. Before doing this, stop the tractor. (See *Stopping*, Next page.)

The gage wheels are primarily an anti-scalp device. Adjust so they are just off the ground. If several cutting heights will be used during a cutting session, set the gage wheels while the mower deck is in the lowest cutting position that will be used.

While mowing extremely rough, uneven or hilly terrain, it is best to allow the mower deck to ride directly on the gage wheels. In this case, set the gage wheels so they contact the ground when the mower deck height has been selected.

Rear Gage Wheel Adjustment, 28" Decks

Remove the nuts securing the gage wheels. Place the gage wheels in the desired position (P, Fig. 33) and secure with nuts. Set both gage wheels to the same height.

33" & 36" Decks

Remove spring pin and washer and position swivel (M, Fig. 34, following page) into desired hole. Replace spring pin. Set both gage wheels to the same position.

CONTROLS AND OPERATION (Cont.)

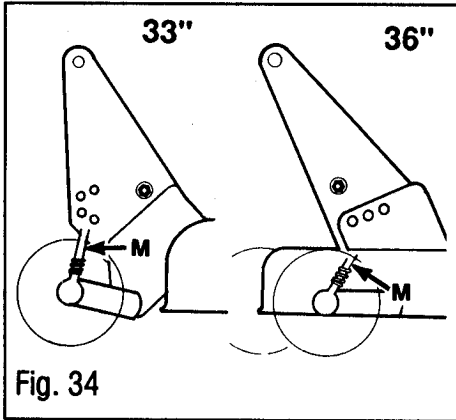

Front Anti-Scalp Wheel Adjustment, 33" Decks only

Remove the nuts securing wheels. Place wheel in the desired position (Q, Fig. 35) and secure with nuts removed earlier. Set both wheels to the same height. Normally, the lower hole should be used.

Stopping (See pages 17 & 18 for description of controls)

1. Remove your foot from drive pedal.
2. Depress brake pedal.
3. Move mower blade drive lever down to the disengaged position.
4. Move engine speed lever to the slow position.
5. Move transmission shift lever out of the N (Neutral) position.
6. Shut engine off by turning the ignition key to the OFF position.
7. Set parking brake by fully depressing brake pedal and moving brake lock to the right.
8. Lower mower lift lever to the lowest (DOWN) position. This will rest the mower deck on the ground.

(Also see *Parking*, below.)

Parking

1. Park the riding mower in a clean, level spot.
2. Park the mower out of the reach of children.
3. If possible, park the riding mower inside a dry enclosure, after the unit has cooled.

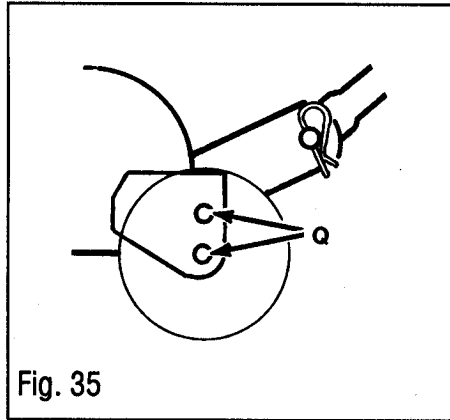

4. Set parking brake.
5. Move transmission shift lever out of the N (Neutral) position.
6. Remove key from key-switch and store it out of the reach of children.
7. Do not park the riding mower on a slope. Block the wheels (place blocks of wood on both sides of the wheels) to prevent it from rolling.
8. Disconnect spark plug wire from spark plug. Prevent spark plug wire from touching spark plug. This will prevent accidental starting.

Mowing Tips

Never mow in R (Reverse).

The best time to mow your lawn is in the early afternoon. This is usually when the grass is most dry. Avoid cutting the lawn when it is wet—wet grass tends to form clumps. Also, the sensitive newly cut areas will not be exposed to direct sun.

For best performance, always keep the mower deck blade(s) sharp. A dull blade tends to tear grass, not cut it.

Do not cut the grass too short, especially in hot weather. This can kill the grass and may allow weeds to gain a foothold. We recommend a cutting height of 2-1/2".

For best results, adjust mower deck height so the blade cuts off only the top third (or less) of the grass.

If the lawn is overgrown, or if you must use the mower on extremely uneven terrain, use the highest cutting height setting.

Unless a special pattern effect is desired (next column), vary your cutting pattern

from week to week. Alternate mowing the lawn from north to south and from east to west. This will help prevent matting and graining of the grass.

For best results, always mow with the engine speed lever in its FAST position.

Make sure the mower deck is level. If the deck is not level it will cut unevenly.

If you are not using an optional bagging attachment, direct the discharge towards the cut portion of the lawn. This will best disperse the clippings. (See also *Testing Height of Cut*, on the previous page.)

Keep the inside of the mowing deck clean and free from grass buildup. (See *STORING YOUR RIDING MOWER*, page 31.)

Special Pattern Effects

It is possible to create patterns in your lawn by mowing in specific directions. You can "train" your lawn to "grain" in a specific way by mowing in the same pattern every time. Some patterns are listed below.

To produce a pattern of contrasting stripes. Mow the lawn in parallel strips that run in opposite directions to each other. (For example North to South and then South to North.)

To produce a "diamond" or "checkerboard" pattern, first mow the lawn in parallel strips. Then, within a couple of days, mow your lawn again in parallel strips but at right angles to the first mowing. (For example: The first mowing is done east to west and/or west to east. The second mowing is then done north to south and/or south to north.)

TRACTOR MAINTENANCE

Engine

FOR SPECIFIC ENGINE MAINTENANCE INSTRUCTIONS, REFER TO ENGINE OWNER'S MANUAL SUPPLIED WITH THE RIDING MOWER. THE ENGINE OWNER'S MANUAL INCLUDES INSTRUCTIONS FOR CHECKING ENGINE OIL LEVEL, CHANGING ENGINE OIL, INSPECTING AND CLEANING ENGINE AIR FILTER, IGNITION SYSTEM MAINTENANCE, AND OTHER IMPORTANT ENGINE MAINTENANCE INFORMATION. FOR FURTHER REPAIRS, CONTACT YOUR LOCAL BOLENS® DEALER.

Lubrication

Refer to Maintenance Chart on Page 32 for lubrication instructions.

Interlock System Test

This riding mower is equipped with an interlock system. This system prevents the operator from starting the engine, if:

- 1.) ...there is no one in the seat.
- 2.) ...the brake pedal is not depressed.
- 3.) ...the mower blade drive lever is in the engaged position.



WARNING!

IF THE INTERLOCK SYSTEM DOES NOT FUNCTION PROPERLY, SHUT THE ENGINE OFF, APPLY THE PARKING BRAKE, ALLOW THE ENGINE TO COOL, DISCONNECT THE SPARK PLUG WIRE AND PREVENT IT FROM TOUCHING THE SPARK PLUG, AND REMOVE THE KEY FROM THE KEYSWITCH. DO NOT USE THE RIDING MOWER UNTIL THE INTERLOCK SYSTEM IS REPAIRED.

FAILURE TO FOLLOW THIS WARNING COULD RESULT IN PERSONAL INJURY OR PROPERTY DAMAGE.

See *Interlock System Test* on page 20, in the CONTROLS AND OPERATION section to perform this test.

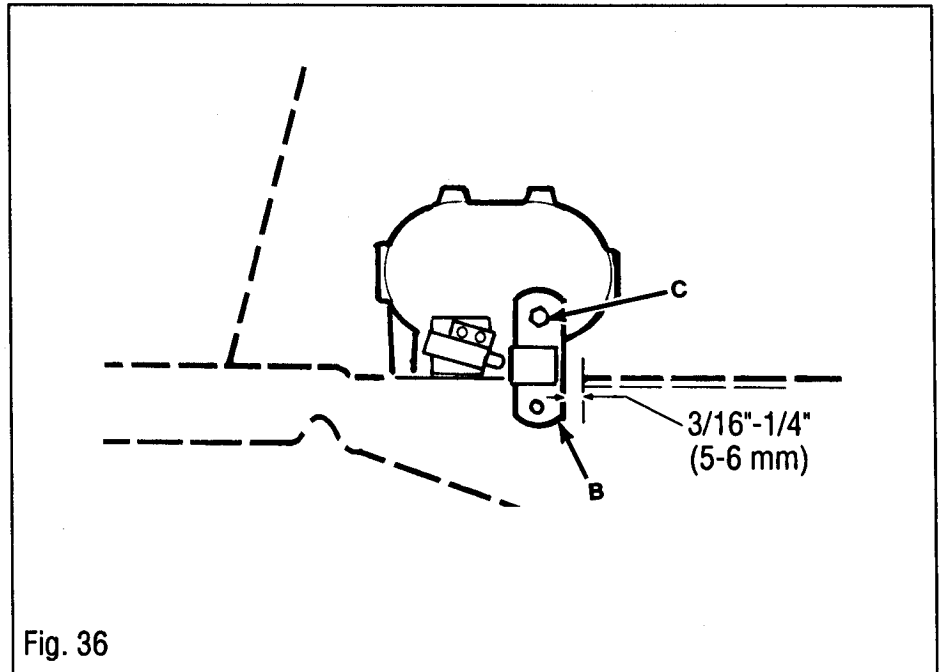

Fig. 36

Brake Adjustment



WARNING!

BEFORE ADJUSTING THE BRAKE, SHUT THE ENGINE OFF, BLOCK THE WHEELS, ALLOW THE ENGINE TO COOL, DISCONNECT THE SPARK PLUG WIRE AND PREVENT IT FROM TOUCHING THE SPARK PLUG, AND REMOVE THE KEY FROM THE KEYSWITCH.

FAILURE TO FOLLOW THIS WARNING COULD RESULT IN PERSONAL INJURY OR PROPERTY DAMAGE.

1. Lift seat and seat support up to gain access to the side of transmission.
2. Turn hex nuts (C, Fig. 36) holding brake lever to left-hand side of transmission to remove any play from the brake system.
3. Have an assistant push firmly on brake pedal. Adjust until a gap of 3/16" (5 mm) to 1/4" (6 mm) exists between front edge of brake lever (B) and forward edge of slot in frame the brake lever goes down through.

NOTE: DO NOT OVER-TIGHTEN NUTS (C) OR THE BRAKE WILL DRAG AND OVERHEAT.

Transmission Drive Belt Replacement



WARNING!

BEFORE REMOVING THE TRANSMISSION DRIVE BELT, SHUT THE ENGINE OFF, BLOCK THE RIDING MOWER'S WHEELS, ALLOW THE ENGINE TO COOL, DISCONNECT THE SPARK PLUG WIRE AND PREVENT IT FROM TOUCHING THE SPARK PLUG, AND REMOVE THE KEY FROM THE KEYSWITCH.

FAILURE TO FOLLOW THIS WARNING COULD RESULT IN PERSONAL INJURY OR PROPERTY DAMAGE.

1. Remove mower deck. See *Mower Deck Removal*, page 25.
2. Move transmission shift lever to N (Neutral).
3. Remove old transmission drive belt and discard.

MAINTENANCE (Cont.)

4. Remove belt guide (C, Fig. 37) behind engine pulley.
5. To install new belt:
 - A. Place belt into sheave (F). It may be necessary to rotate differential to assemble.
 - B. Loosen transmission pulley belt guides (G).
 - C. Loosen idler pulley (H).
 - D. Place forward portion of belt onto transmission pulley (I).
 - E. Place belt between idler pulley (H) and belt guide.
 - F. Re-tighten idler pulley.
 - G. Re-tighten belt guides (G) 1/8" (.32 cm) away from sheave (F).
6. Re-install and re-tighten belt guide (C). Position guide as far forward as possible. After assembly, check clearance between guide (C) and bolt heads on differential. A 1/8" minimum clearance should exist.

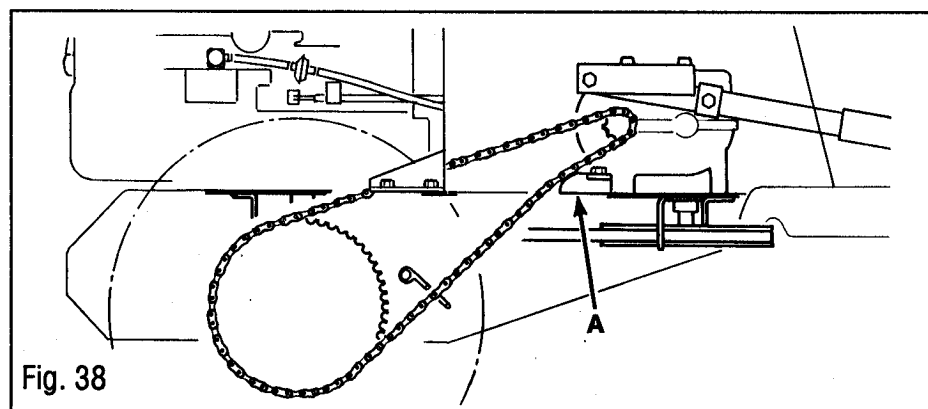
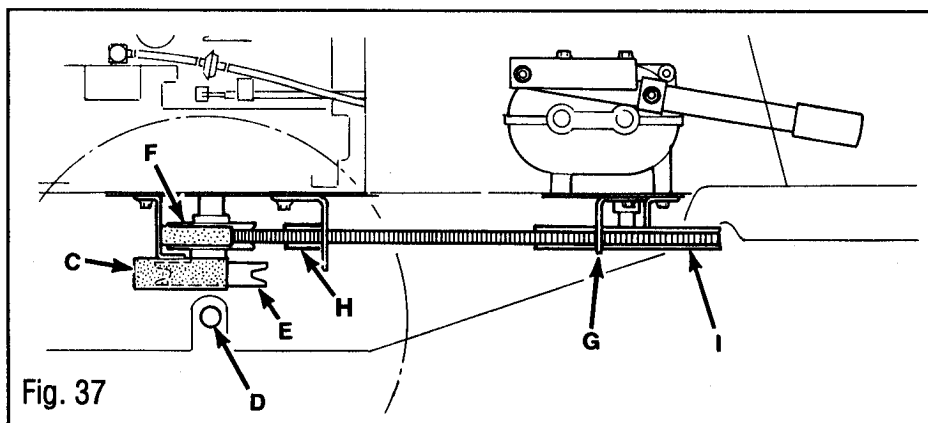

Transmission Drive Belt Guide Adjustments

1. Push drive pedal all the way forward.
2. Loosen and adjust belt guide (C) so there is a 1/8" (3.1 mm) to 3/16" (4.7 mm) gap between upper guide and belt. Re-tighten.
3. Repeat Step 2 for forward belt guide (G).

Drive Chain Adjustment

If drive chain appears to have excessive slack, adjust to prevent it from coming off sprockets.

To adjust:

1. Lift seat and seat support up.
2. Loosen chain tightener (A, Fig. 38).
3. Slide the chain tightener until excess slack is removed.
4. Re-tighten the chain tightener.

Battery Maintenance



DANGER!

BATTERY ELECTROLYTE CAN CAUSE SEVERE BURNS AND BLINDNESS.

WEAR EYE PROTECTION AND PROTECTIVE CLOTHING WHEN WORKING NEAR A BATTERY.

FAILURE TO FOLLOW THIS INSTRUCTION COULD RESULT IN PERSONAL INJURY OR PROPERTY DAMAGE.

IN THE EVENT OF AN ACCIDENT, FLUSH WITH WATER AND CALL A PHYSICIAN IMMEDIATELY.

Keep battery terminals clean and free of corrosion. After cleaning terminals, apply petroleum jelly on them to help prevent corrosion.



DANGER!

BATTERIES CAN GIVE OFF HIGHLY FLAMMABLE HYDROGEN GAS THAT IS EASILY IGNITED.

- NEVER ALLOW A SPARK OR OPEN FLAME NEAR THE BATTERY.
- DO NOT LAY TOOLS ACROSS THE BATTERY TERMINALS.
- DO NOT TOUCH A TOOL FROM THE POSITIVE (+) BATTERY TERMINAL TO THE FRAME OF THE RIDING MOWER.

FAILURE TO FOLLOW THIS INSTRUCTION COULD RESULT IN PERSONAL INJURY OR PROPERTY DAMAGE.

Regularly check electrolyte level in battery. Keep electrolyte within level indicated on battery case. Add **only** distilled water to bring electrolyte to proper level.

MOWER DECK MAINTENANCE

Mower Deck Removal



WARNING!

BEFORE REMOVING OR RE-INSTALLING THE MOWER DECK, SHUT THE ENGINE OFF, APPLY THE PARKING BRAKE, ALLOW THE ENGINE TO COOL, DISCONNECT THE SPARK PLUG WIRE AND PREVENT IT FROM TOUCHING THE SPARK PLUG, AND REMOVE THE KEY FROM THE KEYSWITCH.

FAILURE TO FOLLOW THIS INSTRUCTION COULD RESULT IN PERSONAL INJURY OR PROPERTY DAMAGE.

1. Remove belt guide (P, Fig. 39)
2. Move mower lift lever (I, page 16) downward to set mower in the lowest position.
3. Remove the belt from the engine pulley (B). It may be necessary to turn the differential to remove belt.
4. Remove hitch pins (C) and disconnect lift rods (D).
5. Remove hitch pins and disconnect pivot rods (F) from lift plate.
6. Disconnect mower drive cable cable (S, Figs. 41, 42 & 43 on the following pages) from spring (H). Loosen nuts securing cable to cable support (See Fig. 40). Remove cable from deck.
7. Remove clevis pin from the front of rod end (E, Fig. 39), releasing mower.
8. Slide mower out from under the tractor. Swing the lift rods (D) forward or backward to allow for easy removal.

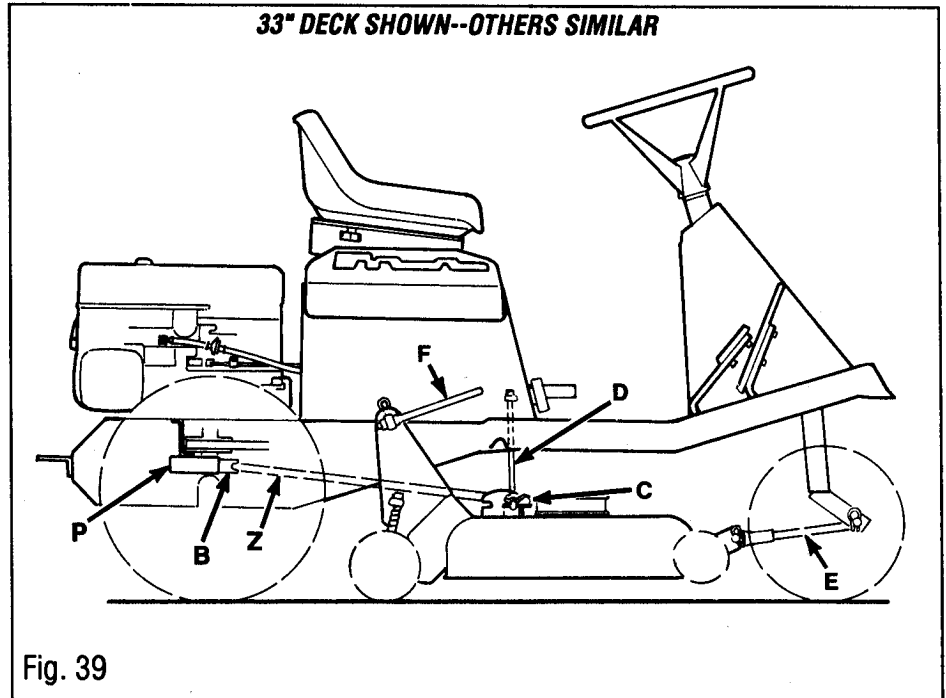

Fig. 39

MOWER BELT REPLACEMENT



WARNING!

BEFORE REPLACING THE MOWER DECK BELT, SHUT THE ENGINE OFF, MOVE THE MOWER BLADE CLUTCH LEVER DOWN TO ITS DISENGAGED POSITION, APPLY THE PARKING BRAKE, ALLOW THE ENGINE TO COOL, DISCONNECT THE SPARK PLUG WIRE AND PREVENT IT FROM TOUCHING THE SPARK PLUG, AND REMOVE THE KEY FROM THE KEYSWITCH.

FAILURE TO FOLLOW THIS INSTRUCTION COULD RESULT IN PERSONAL INJURY OR PROPERTY DAMAGE.

28" Mower Drive Belt Replacement

1. Remove belt guide (P, Fig. 39) and loosen guides (Y & H, Fig. 41 on following page).
2. Rotate idler arm (B, Fig. 41) away from mower sheave and remove old belt.
3. Install new belt (Z) under belt guide (Y) on pulley (X).

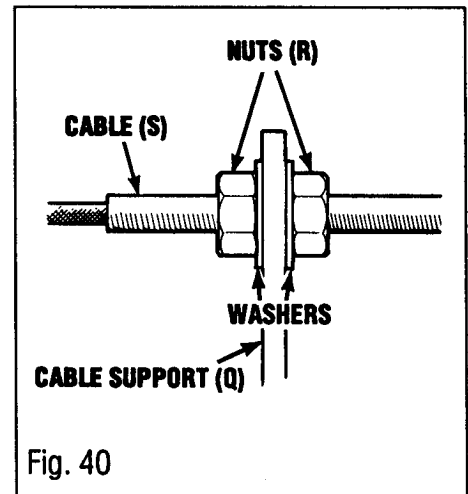

Fig. 40

4. Re-tighten idler pulley bolt (T). Make sure guide (Y) is in approximate position as shown.
5. Assemble belt onto engine sheave and slide belt guide (P, Fig. 39) as far forward as possible. Re-tighten guide (P). NOTE: It may be necessary to rotate differential to assemble. Check clearance between guide (P) and bolt heads on differential. A gap of 1/8" should exist.
6. Lift mower blade drive lever (F, page 15) to engage drive.

MAINTENANCE (Cont.)

7. Re-tighten belt guide (H) $1/16"$ (.15 cm) away from drive belt.

8. With the mower in the highest setting, check clearance between belt at point (AA). If there is not at least a 1" (2.5 cm) gap, move mower ahead by adjusting pivot location on lift arms (E, Fig. 45). It may be necessary to adjust rod (A, Fig. 45) to level mower.

9. With mower blade drive engaged, belt guide (Y) should not contact drive belt.

10. Check to see if mower is level and adjust if necessary (See page 16).

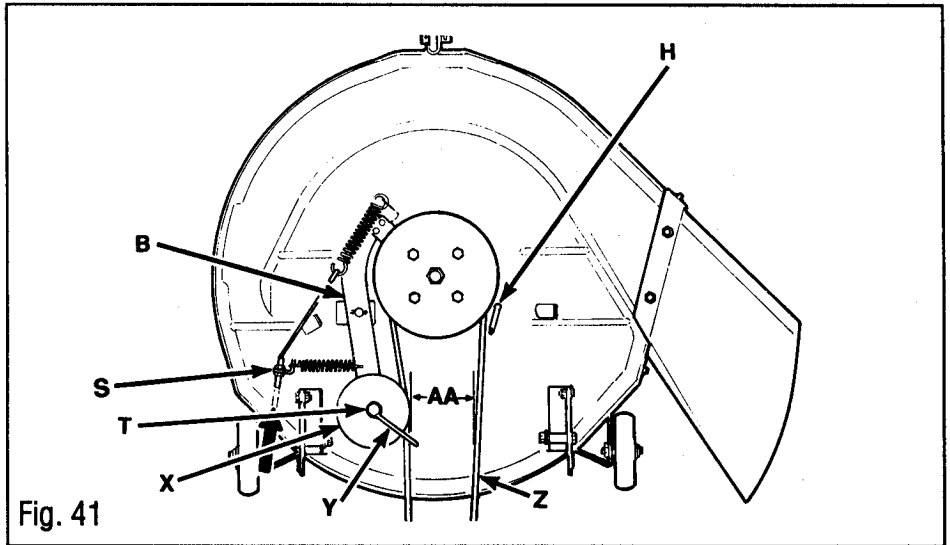

33" Mower Drive Belt Replacement

1. Loosen belt guides (A & B Fig. 42 and (P, Fig. 45).

2. Rotate idler arm (C) away from pulley (R). Replace belt (Z) with new belt.

3. Route belt between idler (Q) and belt guide (A). Place guide (A) in approximate position shown and secure.

4. Place new belt into groove of stationary idler (E) and secure belt guide (B) in rear of slot as shown.

5. Place new belt into groove of engine pulley and assemble belt guide (P, Fig. 45) as far forward as possible. Re-tighten guide (P). Check clearance between guide (P) and bolt heads on differential. A gap of $1/8"$ should exist.

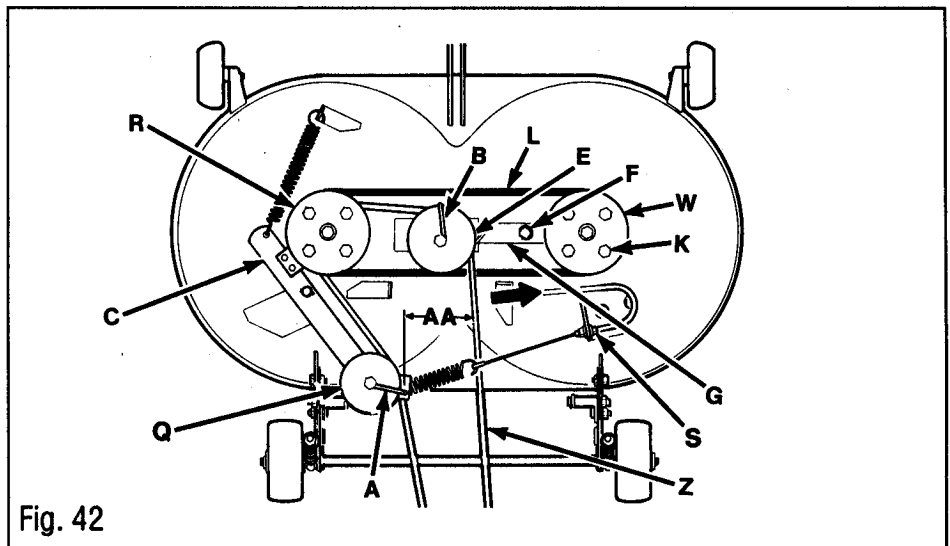

6. Lift mower blade drive lever (F, page 17) to engage drive.

7. With the mower in the highest setting, check clearance between belt at point (AA, Fig. 44). If there is not at least a 1" (2.5 cm) gap, move mower ahead by adjusting pivot location on lift arms (E Fig. 45).

8. Check to see if mower is level and adjust if necessary (See *MOWER DECK LEVELING*, page 16).

33" Mower Blade Belt Replacement

Mower drive belt must first be removed (as described earlier) before doing this repair.

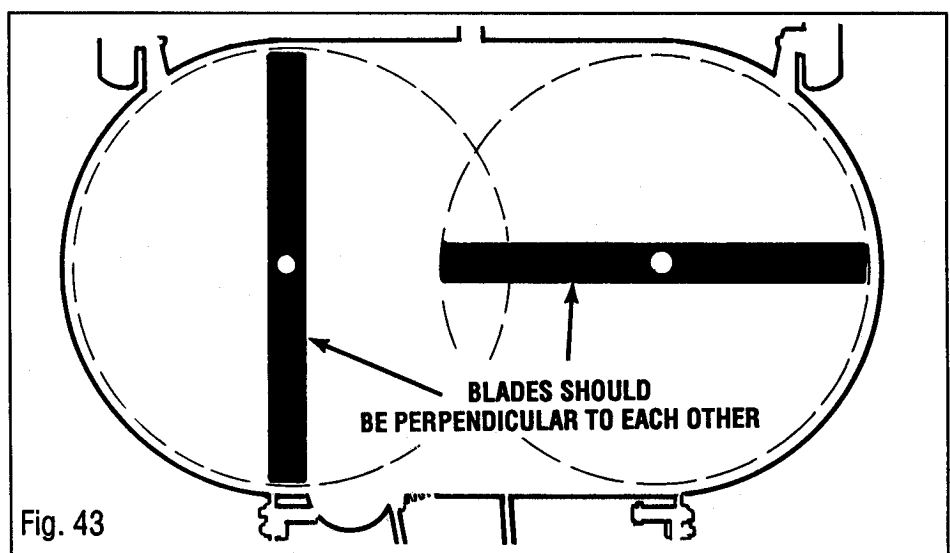

MAINTENANCE (Cont.)

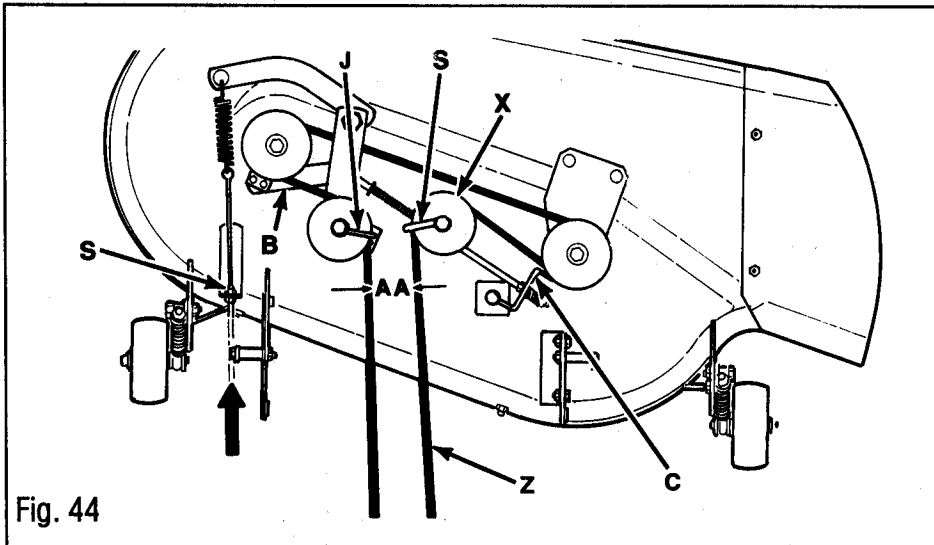

3. Replace belt (Z) with new belt. Place new belt around pulleys, between idlers and belt guides (J & S) as shown in Fig. 44.
4. Secure belt guide (S) and idler in rear of slot as shown.
6. Position guide (J) through hole in bottom of plate and secure in place.
7. Place new belt into groove of engine pulley and slide belt guide (P, Fig. 45) as far forward as possible. Re-tighten guide (P). It may be necessary to rotate differential to assemble belt. After assembly, check clearance between guide (P) and bolt heads of differential. A gap of 1/8" should exist.
8. Lift mower blade drive lever (F, page 17) to engage drive.

9. With the mower in the highest setting, check clearance between belt at point (AA). If there is not at least a 1" (2.5 cm) gap, relocate idler (X) as far ahead as possible. If more adjustment is needed, move mower ahead by adjusting pivot location on lift arms (E, Fig. 45).

10. Check to see if mower is level and adjust if necessary (See *MOWER DECK LEVELING*, page 16).

Mower Deck Re-installation

Follow instructions starting on page 9, *Mower Deck Installation* to re-install the mower deck.

Mower Drive Belt Adjustment Check

Start the riding mower. Engage and disengage the mower blade drive lever (Item F, page 17) while having an assistant watch the mower drive belt. The belt should not move when the mower blade clutch lever is in the disengaged position.

If the belt does move when you perform this check, shut the engine off and adjust as follows:

28" Decks Adjust the mower drive cable end (S, Fig. 42 and S, Fig. 48 on the following page) or move mower back by adjusting pivot location on lift arms (E, Fig. 45). Repeat this test until belt does not move. Check mower leveling after adjusting pivot (E).

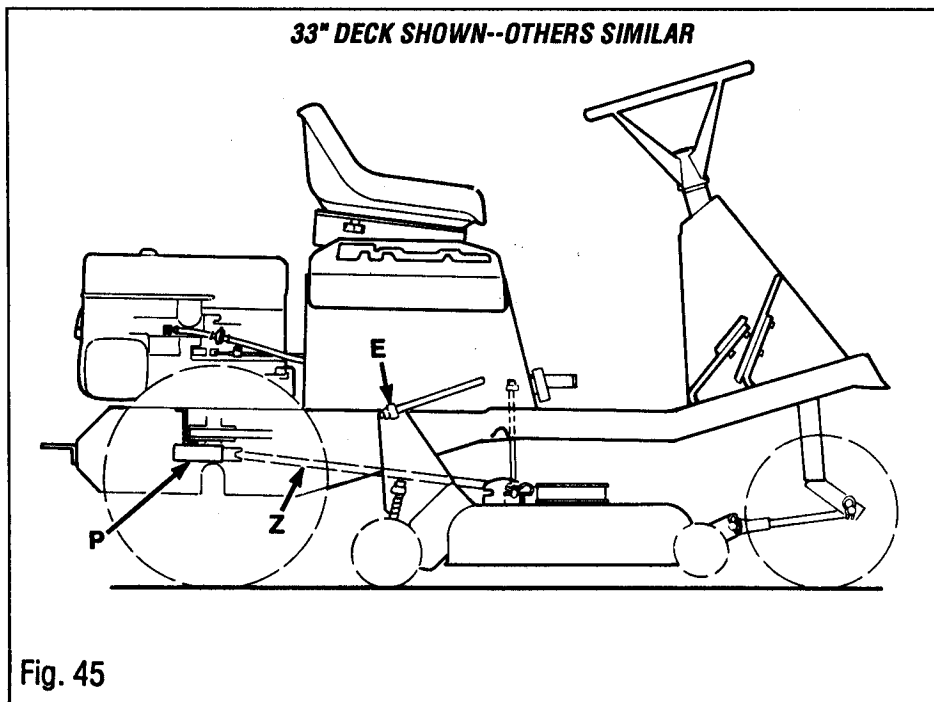

Fig. 45

1. Loosen screw (F, Fig. 42) and rotate arm (G) 90° to the rear.
2. Loosen four mounting bolts (K) securing pulley (W).
3. Slide pulley (W) toward the center.
4. Replace belt (L) with new belt. **IMPORTANT!**—cutting blades **MUST** be perpendicular to each other as shown in Fig. 43.
5. Slide pulley (W) to the right. Rotate

pivot arm (G) back in position so it is applying pressure on pulley (W). Secure mounting bolts (K). Make sure there is clearance between the right-hand mower blade and the deck on the right side.

36" Mower Drive Belt Replacement

1. Loosen belt guides (J & S, Fig. 44 and P, Fig. 45).
2. Rotate idler arm (B, Fig. 44) and brake arm (C), and remove belt (Z).

MAINTENANCE (Cont.)

33" & 36" Decks Adjust the mower drive cable end (S, Figs. 42 & 44 and S, Fig. 48 on the following page) or relocate the adjustable pulley (B, Fig. 42 or X, Fig. 44) within its slot on the idler support bracket. If further adjustment is necessary, move mower ahead by adjusting pivot location on lift arms (E, Fig. 45). Repeat this test until belt does not move. Check mower leveling after adjusting pivots (E).

MOWER DECK BRAKE ADJUSTMENTS

If the mower deck pulleys do not stop rotating within 5 seconds after placing the mower blade drive lever (F, page 17) into the disengaged (DOWN) position, adjust as follows:



WARNING!

BEFORE ADJUSTING THE MOWER DECK BLADE BRAKE, SHUT THE ENGINE OFF, APPLY THE PARKING BRAKE, ALLOW THE ENGINE TO COOL, DISCONNECT THE SPARK PLUG WIRE AND PREVENT IT FROM TOUCHING THE SPARK PLUG, AND REMOVE THE KEY FROM THE KEYSWITCH.

FAILURE TO FOLLOW THIS INSTRUCTION COULD RESULT IN PERSONAL INJURY OR PROPERTY DAMAGE.

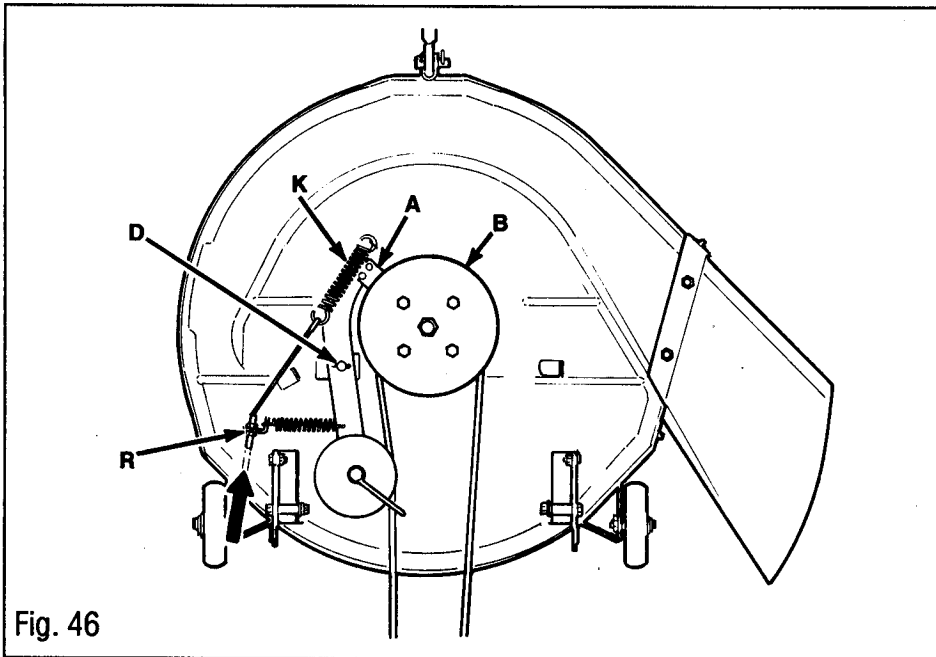

Fig. 46

28" Mower Deck Brake Adjustment

1. Move mower blade drive lever to the disengaged (DOWN) position.
2. Adjust cable and spring (K, Figs. 46 & 48) at nuts (R, Figs. 46 & 48) until all slack in spring (K, Fig. 46) has been taken up. *WHEN ADJUSTED, SPRING (K) SHOULD NOT BE UNDER TENSION*
3. If brake pad (A, Fig. 46) is not centered in pulley (B), Adjust idler arm pivot (D) as necessary, by re-locating washers at pivot.
4. If blade still does not stop within 5 seconds after the mower drive has been disengaged, replace brake pad (A).

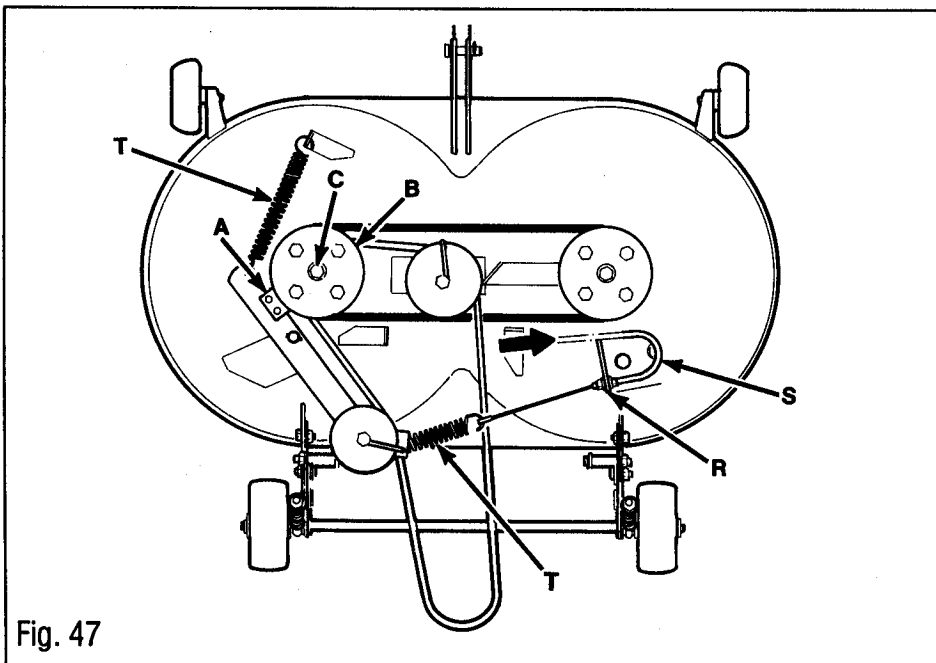

Fig. 47

33" Mower Deck Brake Adjustment

1. Move mower blade drive lever to the disengaged (DOWN) position.

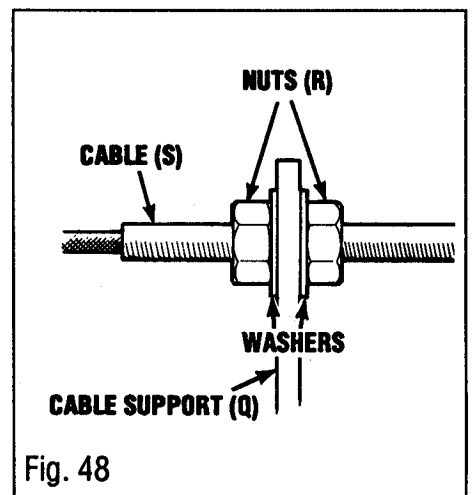

Fig. 48

MAINTENANCE (Cont.)

2. If brake pad (A, Fig. 47) does not squarely contact both top and bottom surfaces of pulley (B), re-position pulley (B) as follows:

Pulley (B) has one washer on top and on bottom. To raise pulley up, remove screw (C), place both washers on bottom and re-install screw (C). To drop pulley down, remove screw (C), place both washers on top and re-install screw (C).

3. Adjust cable (S, Figs. 48 & 49) at nuts (R, Fig. 47 & 48) so there is a slight slack in spring (T, Fig. 47). *WHEN ADJUSTED, SPRING (T) SHOULD NOT BE UNDER TENSION*

4. If blade still does not stop within 5 seconds after the mower drive has been disengaged, replace brake pad (A, Fig. 47).

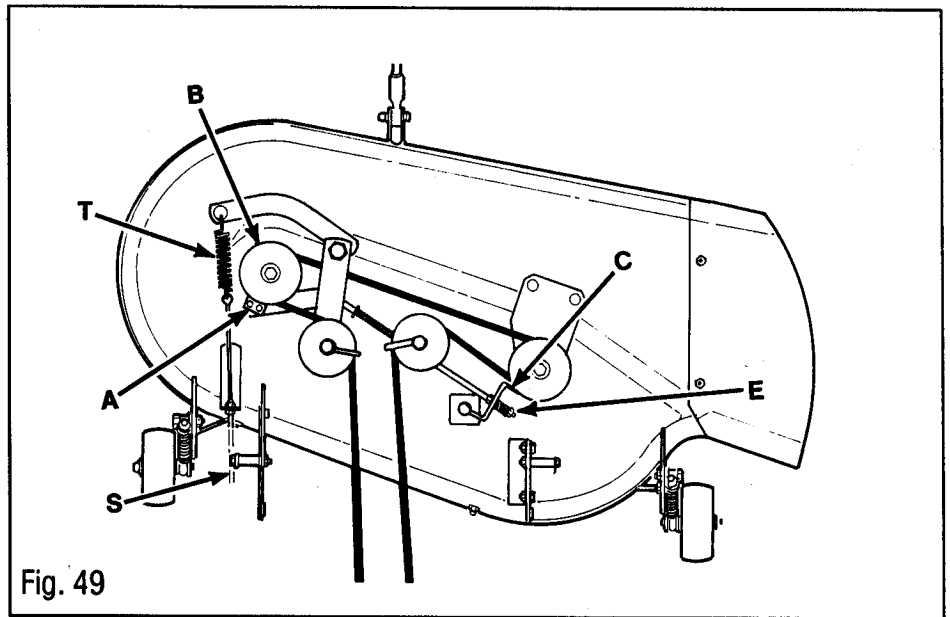

Fig. 49

36" Mower Deck Brake Adjustment

1. Move mower blade drive lever to the disengaged (DOWN) position.
2. Adjust brake pad (A, Fig. 49) so it squarely contacts pulley (B).
3. Adjust nut (E, Fig. 49) until the leg on brake arm (C) contacts belt.
3. Adjust cable (S, Figs. 48 & 49) at nuts (R, Fig. 48) so there is a slight slack in spring (T, Fig. 44). *WHEN ADJUSTED, SPRING (T) SHOULD NOT BE UNDER TENSION*
4. If blade still does not stop within 5 seconds after the mower drive has been disengaged, replace brake pad (A, Fig. 49).

Other Deck Adjustments

Information about other deck adjustments can be found in *DECK ADJUSTMENT*.

MOWER DRIVE CABLE REPLACEMENT

1. Unhook cable from mower deck and remove screw and nut (P & O, Fig. 50) securing cable to mower blade drive lever.
2. Loosen nuts (Q) securing cable adjusting barrel to tractor. Remove cable.
3. Route new cable up into tractor. 28" and 36" deck cables are routed through front hole (T) 33" deck cable is routed through back hole (U). Secure cable

adjusting barrel to tractor. Secure cable end to the right-hand side of mower blade drive lever (M) with screw and nut (P & O). Re-attach cable to mower deck.

Blade Maintenance



WARNING!

WHENEVER YOU INSPECT OR WORK ON THE MOWER BLADE(S), DISCONNECT THE MOWER BLADE DRIVE, SHUT THE ENGINE OFF, BLOCK THE RIDING MOWER'S WHEELS, ALLOW THE ENGINE TO COOL, DISCONNECT THE SPARK PLUG WIRE AND PREVENT IT FROM TOUCHING THE SPARK PLUG, AND REMOVE THE KEY FROM THE KEYSWITCH.

FAILURE TO FOLLOW THIS INSTRUCTION COULD RESULT IN PERSONAL INJURY OR PROPERTY DAMAGE.

Blade Inspection

Periodically examine ends of mower blade(s) and area between turned-up and flat portions on the top of blade.

When mowing grass in dry or sandy conditions, abrasive particles wear away the metal connecting these portions of the blade. (A, Fig. 51 on the following page)

If a separation starts forming in the blade as shown in (B, Fig. 51), you must replace the blade.

If this wear is allowed to continue, the separation will enlarge and eventually allow a portion of the blade to break off.

For best results, always keep blade(s) sharp. A sharp blade will cleanly cut grass. A dull blade tends to tear it. See next page for blade sharpening information.

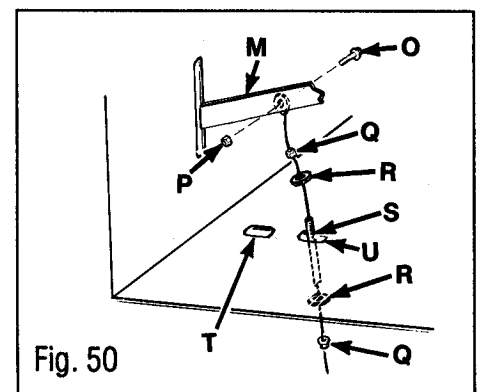

Fig. 50

MAINTENANCE (Cont.)

Mower Deck Blade Replacement



WARNING!

BEFORE REPLACING THE MOWER BLADE(S), DISCONNECT THE MOWER BLADE DRIVE, SHUT THE ENGINE OFF, CHOCK THE RIDING MOWER'S WHEELS, ALLOW THE ENGINE TO COOL, DISCONNECT THE SPARK PLUG WIRE AND PREVENT IT FROM TOUCHING THE SPARK PLUG, AND REMOVE THE KEY FROM THE KEYSWITCH.

FAILURE TO FOLLOW THIS INSTRUCTION COULD RESULT IN PERSONAL INJURY OR PROPERTY DAMAGE.

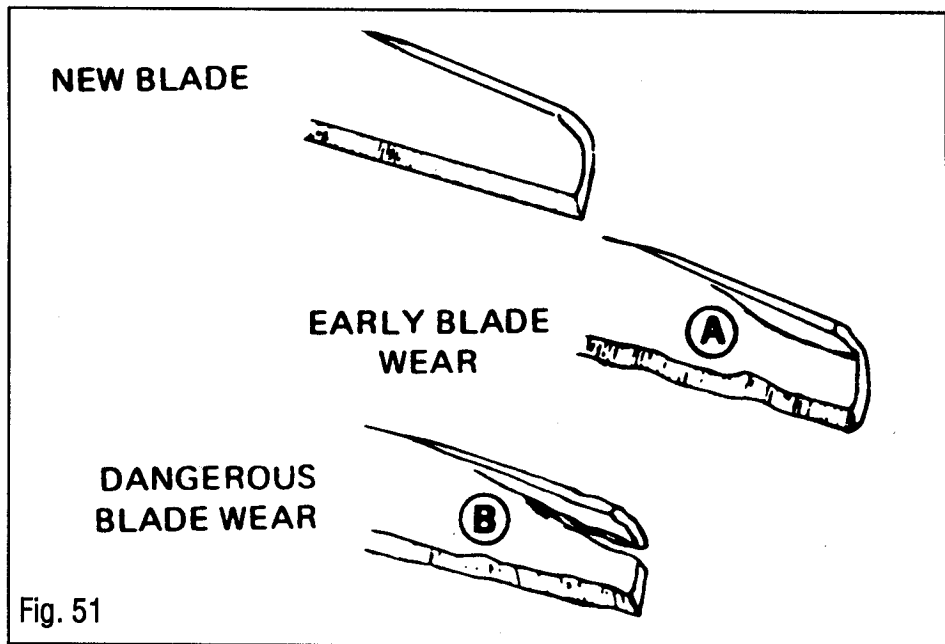

Fig. 51

BLADE REMOVAL

28" Blade Removal

1. Wrap heavy rags around blade (or wear heavy leather gloves). Hold blade to prevent it from turning.
2. Before removing blade, note position: the raised corners of the blade point up.
3. Remove two screws (A, Fig. 52) and lock washers (B) securing plate (C), and blade (D) to the spindle assembly (E).

Models 13055, 13057, 13067 & 13068

1. Wrap heavy rags around blade (or wear heavy leather gloves). Hold blade to prevent it from turning.
2. Remove blade bolt (F, Fig. 52), spring washer (G), and spindle washer (I) securing blade (H) to bottom of blade adapter (J).
3. Remove blade.

33" Blade Removal

1. Wrap heavy rags around blade (or wear heavy leather gloves). Hold blade to prevent it from turning.
2. Before removing blade, note position: the raised corners of the blade point up.

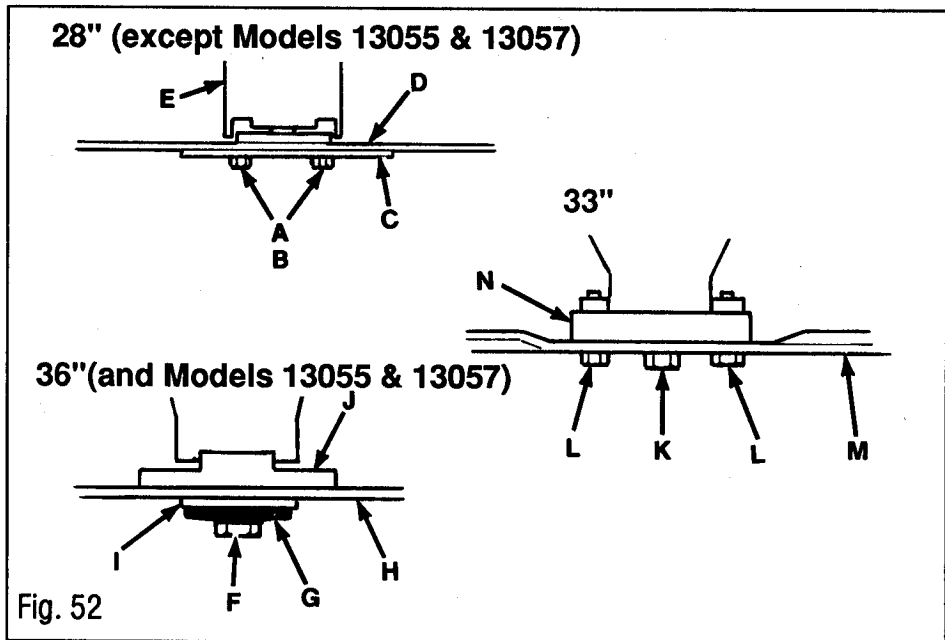

Fig. 52

3. Loosen center bolt (K). Remove two outer bolts and nuts (L). Remove center bolt (K).

36" Blade Removal

1. Wrap heavy rags around blade (or wear heavy leather gloves). Hold blade to prevent it from turning.
2. Before removing blade, note position: the raised corners of the blade point up.

3. Remove blade bolt (F, Fig. 52), spring washer (G), and spindle washer (I) securing blade (H) to bottom of blade adapter (J).

4. Remove blade.

BLADE INSTALLATION

28" Blade Installation

1. Re-position blade in place.

MAINTENANCE (Cont.)

2. Re-position plate (C) on bottom of blade (D). Secure blade and plate with two *new* blade screws (A) and *new* lock washers (B) to bottom of spindle assembly (E). Torque screws (A) 25 -30 foot-pounds.

Models 13055, 13057, 13067 & 13068

1. Re-position blade on bottom of spindle.
2. Secure with *new* blade bolt (F), spring washer (G) and spindle washer (I). Torque blade bolt (F) from 35 foot-pounds.

33" Blade Installation

1. Re-position blade in place.
2. Install two *new* outer bolts and nuts (L).
3. Install *new* center bolt (K).
4. Torque bolts (L & K) to 30 foot-pounds.
5. Make sure the blades are 90° from each other (See Fig. 43, page 26).

36" Blade Installation

1. Re-position blade in blade adapter (J).
2. Secure with *new* blade bolt (F), spring washer (G) and spindle washer (I). Torque blade bolt (F) from 50 to 70 foot-pounds.

Mower Deck Blade Re-sharpening and Balancing

The deck blade(s) can be sharpened with a file or a grinder. A local sharpening service can also sharpen them.

To sharpen:

1. Remove equal amounts of metal from both ends of blades along cutting edges. Sharpen cutting edges at a 25-30° angle.
2. Check balance of blade(s) by inserting a nail or screwdriver through center hole. Hold nail level with ground so blade can rotate on it. Grind or file off heavier end, as required, to balance blade.

An unbalanced blade will cause vibration and undue wear on component parts.

STORING YOUR RIDING MOWER

When storing the riding mower for more than 30 days:

1. Move unit outside and run engine until it stops from lack of fuel.
2. After engine has cooled, store unit in a dry, protected place.
3. Remove, clean, and re-gap spark plug. See *Engine Owner's Manual*, supplied with the unit, for the correct gap.
4. Pour one ounce of engine oil through spark plug hole into engine. Place a clean rag over spark plug hole and crank engine several revolutions to distribute oil on cylinder walls.
5. Re-install spark plug. Leave spark plug wire disconnected.
6. Fully charge battery once a month during storage using only a trickle charger (not an automotive-type charger, which could ruin the battery). This will ensure peak battery power.
7. Clean underside of the mower deck. Use a hose, a wire brush or a scraper to remove any grass buildup. (Heavy grass buildup can seriously effect the performance of any mowing deck, especially the 33" mulching deck.) To clean deck, remove it, use the optional Model 6957 storage stand (see page 6), available from your local Bolens® dealer, or set the front of your unit on jackstands.



WARNING!

JACKSTANDS MUST BE USED WITH EXTREME CAUTION. ALWAYS SET THE PARKING BRAKE AND SECURELY BLOCK THE REAR WHEELS WHENEVER JACKSTANDS ARE USED.

FAILURE TO FOLLOW THIS INSTRUCTION COULD RESULT IN PERSONAL INJURY OR PROPERTY DAMAGE.

8. Thoroughly examine entire unit for loose hardware or any damaged or worn parts. Replace or repair as needed.
9. Sand and re-paint any rusted areas.
10. Cover your unit with a breathable cover.

11. Block all four wheels. (Place wooden blocks on both sides of wheels.) This helps prevent any accidental movement.



WARNING!

ELECTROLYTE CAN LEAK OUT OF THE BATTERY VENT TUBE IF THE MOWER IS TIPPED UP ON END OR ON ITS SIDE.

REMOVE THE BATTERY BEFORE TIPPING THE MOWER ON ITS END OR ON ITS SIDE.

DRAIN FUEL TANK BEFORE TIPPING THE MOWER ON ITS END OR ON ITS SIDE.

GASOLINE IS HIGHLY FLAMMABLE AND ITS VAPORS ARE EXPLOSIVE.

DO NOT ADD GASOLINE TO THE TANK WHILE THE ENGINE IS RUNNING. IF THE ENGINE HAS BEEN RUNNING, ALLOW IT TO COOL FOR SEVERAL MINUTES.

DO NOT ALLOW OPEN FLAMES, SPARKS, MATCHES, OR SMOKING NEARBY WHEN WORKING WITH GASOLINE.

DRAIN THE FUEL TANK OUTDOORS IN A WELL-VENTILATED AREA. WIPE UP ANY SPILLS BEFORE STORING THE UNIT.

NEVER BRING A GASOLINE CAN NEAR THE BATTERY POSTS. A SHORT CIRCUIT CAUSED BY TOUCHING THE POSITIVE (+) POST AND ANY METAL COULD CAUSE AN EXPLOSION OF GASOLINE OR BATTERY GASES.

FAILURE TO FOLLOW THIS INSTRUCTION COULD RESULT IN PERSONAL INJURY OR PROPERTY DAMAGE.

MAINTENANCE (Cont.)

Maintenance Chart

	Before Each Use	After Each Use	Every 25 Hours	Every 40 Hours	Every 50 Hours	Monthly	Each Season
Check for loose or missing fasteners	✓						
Check engine oil level	✓						
Clean mower deck		✓					
Change engine oil			✓				
Clean air cleaner element			✓				
Grease rear axle bearings and front spindle			✓				
Check mower blade(s) for balance, straightness, & sharpness. Service if necessary				✓			
Check, clean & re-gap spark plug					✓		
Check chain tension. Adjust if necessary						✓	
Lightly oil steering pivot link and rod, brake and clutch pivot brackets (4) and idler pivots							✓
Grease front wheel bearings			✓				

Troubleshooting Chart

Before performing any of the corrections in this Troubleshooting Chart, refer to the appropriate information contained in this manual for the correct safety precautions and operating or maintenance procedures.

ENGINE PROBLEMS

PROBLEM	POSSIBLE CAUSE	CORRECTION
Engine does not start	No fuel in tank (8HP engines may still have a small amount in tank and still not start)	Check fuel level. Add if necessary
	Blown 15 amp fuse (in wiring harness beneath seat)	Replace fuse
	Spark plug wire not connected	Connect spark plug wire
	Throttle not in CHOKE position	Move throttle to CHOKE position

MAINTENANCE (Cont.)

ENGINE PROBLEMS (Cont.)		
PROBLEM	POSSIBLE CAUSE	CORRECTION
Engine does not start (Cont.)	Interlock switch inactivated, parking brake not set and/or mower blade drive activated	Operator must be on the seat, the brake pedal must be depressed, and the mower blade drive must be disengaged or the interlock system will prevent engine from starting
	Battery discharged or dead. Poor battery lead connection	Charge/replace battery. Check, clean and tighten battery leads as necessary
	Loose, broken or corroded interlock, ignition or starter wires	Find and repair
	Bad spark plug	Clean or replace and re-gap as necessary
	Fuel tank vent plugged	Clear vent in fuel tank cap
	Malfunctioning starter motor	Have unit serviced by authorized dealer
	Malfunctioning engine	Have unit serviced by authorized dealer
	Water in fuel. Stale fuel	Drain fuel tank. Re-fill with fresh fuel.
	Malfunctioning starter solenoid	Replace solenoid
Engine runs poorly	Bad spark plug	Clean or replace and re-gap as necessary
	Clogged air cleaner	Clean or replace as necessary
	Throttle out of adjustment	Refer to engine owner's manual
	Water in fuel. Stale fuel	Drain fuel tank. Re-fill with fresh fuel.
	Carburetor out of adjustment	Refer to engine owner's manual
	Engine lugs down (overloaded)	Raise cutting height
Engine overheats	Loose spark plug	Tighten spark plug
	Low oil level	Add oil as necessary
	Engine over-filled with oil	Remove oil as necessary
	Engine air screen and/or cooling fins clogged with debris	Clean debris from engine
	Carburetor out of adjustment	See engine owner's manual
MOWER DECK PROBLEMS		
PROBLEM	POSSIBLE CAUSE	CORRECTION
Blade will not engage	Mower blade drive not activated	Lift mower blade drive lever into engaged position
	Loose belt(s)	Tighten belt(s)
	Worn or broken belt	Replace belt
	Missing or loose idler pulley	Replace/tighten
	Brake riding against deck pulley	Adjust brake

MAINTENANCE (Cont.)

MOWER DECK PROBLEMS (Cont.)		
PROBLEM	POSSIBLE CAUSE	CORRECTION
Blade will not engage (Cont.)	Broken or missing woodruff key in engine pulley	Replace woodruff key
	Broken or missing woodruff key in mower blade spindle shaft(s) (Models 13000, 13001, 13002 & 13004 only)	Replace woodruff key(s)
	Broken, worn or maladjusted mower blade drive cable	Replace/adjust cable
Deck cuts poorly	Dull blade(s)	Sharpen or replace blade(s) as necessary
	Loose belt(s)	Tighten belt(s)
	Brake riding against deck pulley	Adjust brake
	Deck height improperly set or deck not level	Adjust deck
	Loose blade bolt(s)	Tighten blade bolt(s)
	Gage wheels set incorrectly	Adjust gage wheels
	Blade(s) installed upside-down	Install blade(s) with bent corners facing up
Deck gives sloping cut	Deck is not level	Adjust deck
	Tires are not evenly inflated	Check tire pressure. Adjust as necessary
RIDING MOWER PROBLEMS		
PROBLEM	POSSIBLE CAUSE	CORRECTION
Drive does not engage	Worn or broken belt	Replace and adjust belt
	Belt brake improperly adjusted	Adjust brake
	Drive chain has jumped sprocket	Re-install chain and adjust
	Broken, worn or maladjusted mower blade drive cable	Replace/adjust cable
	Broken or missing woodruff key in engine pulley	Replace woodruff key
	Loose belt(s)	Tighten/replace belt as necessary
	Transmission malfunction	Have unit serviced by authorized dealer
Drive is engaged all the time	Belt improperly adjusted	Adjust belt
	Transmission malfunction	Have unit serviced by authorized dealer
	Belt guides improperly adjusted	Adjust belt guides
Brake does not function	Swivel at rear of brake rod is improperly adjusted	Adjust swivel
	Disconnected brake rod	Re-connect brake rod
	Transmission malfunction	Have unit serviced by authorized dealer
Steering wheel does not turn wheels	Missing roll pin from base of steering wheel	Re-install roll pin
	Link arm not connected to steering shaft	Re-connect. Replace hardware if necessary

MAINTENANCE (Cont.)

RIDING MOWER PROBLEMS (Cont.)		
PROBLEM	POSSIBLE CAUSE	CORRECTION
Steering wheel does not turn wheels (Cont.)	Link arm not connected to spindle arm	Re-connect. Replace hardware if necessary
	Tie rod not connected	Re-connect. Replace hardware if necessary
Steering is rough or loose	Front tires under-inflated	Inflate tires to correct pressure (See pg. 16)
	Worn steering bearings at top and/or bottom of steering shaft	Replace bearings
	Loose or worn steering parts such as front wheel spindles, front wheel bushings, axle pivot bolt, front axle assembly, tie rod or steering shaft connections	Replace worn parts/tighten loose connections
Unit vibrates or is excessively noisy	Loose engine mounting bolts	Tighten hardware
	Loose engine pulley	Tighten pulley hardware
	Mower deck blades out of balance and/or loose.	Balance and/or tighten blades
	Worn mower blade spindle bearings	Replace bearings
Units pulls to one side when driven on level ground	One front tire is underinflated	Inflate front tires evenly (See pg. 16)

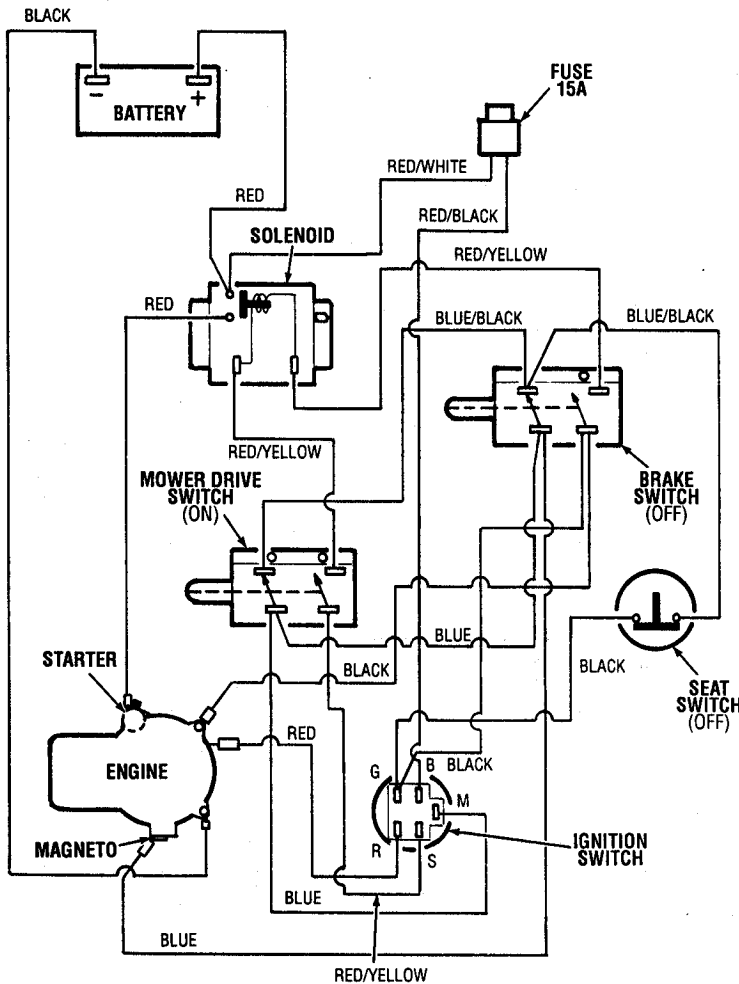

WIRING DIAGRAM

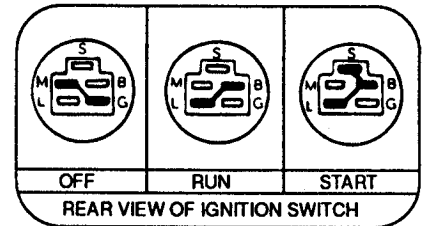

LIMITED WARRANTY

I. PRODUCTS COVERED

This warranty applies to all Bolens® branded equipment, Troy-Bilt® branded tractors, mulching mowers, snow casters, gas and electric sprayers, and all W-W Grinder® branded equipment to include their attachments and/or accessories and all Troy-Bilt® branded equipment sold as a commercial - institutional - industrial - rental or demonstrator application.

II. PRODUCT WARRANTY: NON COMMERCIAL RESIDENTIAL: THREE YEAR LIMITED WARRANTY

All new Bolens®, Troy-Bilt®, and W-W Grinder® equipment specified above is warranted by Garden Way, Inc. to the original retail purchaser only, to be free from defects in material and workmanship, under normal use and service for a period of three (3) years from date of purchase.

Engines manufactured by Briggs & Stratton, Kohler and Tecumseh or transmissions manufactured by Peerless will also be warranted for this three year warranty period through the authorized repair stations of their respective manufacturers.

EXCLUSIONS — The following items are not covered under the second and third year of this extended home use limited warranty: Belts, Hoses, Seats, Batteries, Blades, Knives, Tines, Filters, Tires, Wheels, Paint and Appearance Items, Light Bulbs, and similar items which are normally replaced through periodic maintenance.

III. PRODUCT WARRANTY: COMMERCIAL — INSTITUTIONAL — INDUSTRIAL — RENTAL — DEMONSTRATOR: ONE YEAR LIMITED WARRANTY

The Commercial, Institutional, Industrial, Rental and Demonstrator Limited Warranty covering defects on material and workmanship will be for a period of one (1) year, from date of purchase on all Bolens®, Troy-Bilt® and W-W Grinder® units and their manufactured attachments. This warranty applies to the original purchaser only.

Engines manufactured by Briggs & Stratton, Kohler and Tecumseh, and transmissions manufactured by Peerless will also be warranted for this one (1) year warranty period through the authorized repair stations of their respective manufacturers.

IV. GENERAL INFORMATION

Garden Way, Inc.'s obligation under this warranty is limited to the repair or replacement, at its option, by an authorized Garden Way equipment dealer, of any part found to be defective in material or workmanship, without charge for parts and labor.

In order to obtain warranty service, the owner is responsible for:

- 1) Providing proof of purchase documentation, ownership registration or copy of bill of sale.
- 2) Informing any authorized Garden Way equipment dealer of the defect and making the product available for repair. (Charges for pick-up, delivery and service calls are not covered by this warranty.)

This warranty does not cover defects, malfunctions or failures caused by:

- 1) Use of unauthorized accessories or attachments.
- 2) Lack of reasonable and necessary maintenance as specified in the "Operation and Safety Instructions".
- 3) Misuse, accidents or normal wear.

DISCLAIMER OF CONSEQUENTIAL DAMAGES: GARDEN WAY, INC. SHALL NOT BE LIABLE UNDER ANY CIRCUMSTANCES FOR ANY INCIDENTAL OR CONSEQUENTIAL DAMAGES OR EXPENSE OF ANY KIND, INCLUDING BUT NOT LIMITED TO COST OF EQUIPMENT RENTAL, LOSS OF PROFITS OR COST OF HIRING SERVICES TO PERFORM TASKS NORMALLY PERFORMED BY THE EQUIPMENT.

LIMITATION OF IMPLIED WARRANTIES: ANY IMPLIED WARRANTIES, INCLUDING WITHOUT LIMITATION ANY IMPLIED WARRANTY OF MERCHANTABILITY OR FITNESS FOR A PARTICULAR PURPOSE, SHALL BE LIMITED IN DURATION TO A PERIOD OF THREE YEARS (1 YEAR IF PRODUCT IS PURCHASED FOR COMMERCIAL, INSTITUTIONAL, INDUSTRIAL, RENTAL OR DEMONSTRATOR USE) FROM THE DATE OF SALE.

SOME STATES DO NOT ALLOW THE EXCLUSION OR LIMITATION OF INCIDENTAL OR CONSEQUENTIAL DAMAGES, OR LIMITATIONS ON HOW LONG IMPLIED WARRANTY LASTS. THEREFORE, THE ABOVE LIMITATION OR EXCLUSION MAY NOT APPLY TO YOU.

This warranty gives you specific legal rights, and you may also have other rights which vary from state to state.

Garden Way, Inc.
102nd & 9th Avenue
Troy, New York 12180

PHONE: (414) 284-5521
FAX: (414) 284-3965