



## MODEL 125BO LP and 125BO NG - OUTDOOR MODEL

For exterior use only

Piezo Ignition

Suitable for heating potable water only

Not approved for space heating purposes

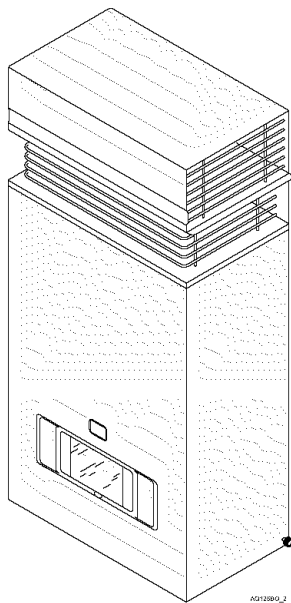

AG12880\_2

### AQ 125 BO NG - Natural Gas

### AQ 125 BO LP - Liquefied Petroleum (LP) Gas

**Warning:** If the information in this manual is not followed exactly, a fire or explosion may result causing property damage, personal injury or death. Do not store or use gasoline or other flammable vapor and liquids in the vicinity of this or any other appliance.

Improper installation, adjustment, alteration, service or maintenance can cause injury or property damage. Refer to this manual. For assistance or additional information consult a qualified installer, service agency or the gas supplier.

In the Commonwealth of Massachusetts this product is approved only for seasonal use. Installation must be performed by a licensed plumber or gas fitter.

Upon completion of the installation, these instructions should be handed to the user of the appliance for future reference.

#### What to do if you smell gas

- Close gas valve.
- Do not try to light any appliance.
- Do not touch any electrical switch; do not use any phone in your building.
- If you cannot reach your gas supplier, call the fire department.
- Immediately call your gas supplier from a neighbor's phone. Follow the gas supplier's instructions
- Installation and service must be performed by a qualified installer, service agency or the gas supplier.

# Index

<b>1</b>	<b>Warning</b>	<b>2</b>
<b>2</b>	<b>Appliance details</b>	<b>4</b>
2.1	Features	4
2.2	AQ125 BO specifications (Technical data)	4
2.3	Unpacking the AQ-125-BO heater	5
2.4	General rules to follow for safe operation	5
2.5	Dimensions and installation clearances	6
<b>3</b>	<b>Installation instructions</b>	<b>7</b>
3.1	Introduction	7
3.2	Proper location for installing your heater	7
3.3	Heater placement and clearances	8
3.4	Mounting installation	8
3.5	Gas piping & connections	10
3.6	Measuring gas pressure	12
3.7	Water connections	12
3.8	Electrical connections	13
<b>4</b>	<b>Operation instructions</b>	<b>14</b>
4.1	For your safety read before operating your water heater	14
4.2	Lighting instructions	14
4.3	To turn off appliance	14
4.4	Setting the water temperature	14
<b>5</b>	<b>Maintenance and service</b>	<b>16</b>
5.1	Maintenance intervals	16
5.2	Water valve	16
5.3	Pilot	16
5.4	Main burners	16
5.5	Vent assembly	16
5.6	Mineral scale build-up	16
<b>6</b>	<b>Troubleshooting</b>	<b>17</b>
6.1	Introduction	17
6.2	Pilot will not light	17
6.3	Pilot will light but not stay on when button released	17
6.4	Burner do not ignite with water flow	17
6.5	Hot water temp fluctuates from hot to cold	17
6.6	Water is too hot	18
6.7	Water is not hot enough	18
<b>7</b>	<b>Interior components and diagram parts list</b>	<b>19</b>
7.1	Interior components	19
7.2	Components diagram	20
7.3	Parts list	21
<b>8</b>	<b>Protecting the environment</b>	<b>22</b>
<b>9</b>	<b>Twelve Year Limited Warranty</b>	<b>23</b>

## 1 Warning



**Warning:** If the information in this manual is not followed exactly, a fire or explosion may result causing property damage, personal injury or death.



**Warning:** Improper installation, adjustment, alteration, service or maintenance can cause injury or property damage. Refer to this manual. For assistance or additional information consult a qualified installer, service agency or the gas supplier. Upon completion of the installation, these instructions should be handed to the user of the appliance for future reference.

### Featuring

Piezo Ignition

### For your safety

Do not store or use gasoline or other flammable, combustible or corrosive vapors and liquids in the vicinity of this or any other appliance.



**Warning:** Carefully plan where you install the heater. If a gas appliance is not installed correctly, fatal accidents can result from lack of air, carbon monoxide poisoning or fire.



**Warning:** Place the heater in a location where water leaks will do **NO DAMAGE** to adjacent areas.

### What to do if you smell gas

- Close gas valve.
- Do not try to light any appliance.
- Do not touch any electrical switch; do not use any phone in your building.
- Immediately call your gas supplier from a neighbor's phone. Follow the gas supplier's instructions.
- If you cannot reach your gas supplier, call the fire department.
- Installation and service must be performed by a qualified installer, service agency or the gas supplier.



**Warning:** The heater must be isolated from the gas supply piping system during any pressure testing of that system at test pressures equal to or more than 0.5 psig.



**Caution:** Any changes or modifications not expressly approved by the party responsible for compliance could void the user's authority to operate the equipment.

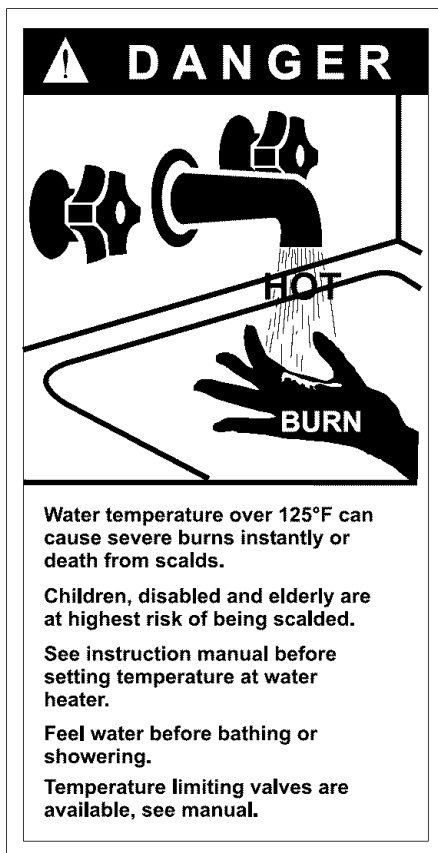

Fig. 1

**⚠ DANGER**

**⚠ Vapors from flammable liquids will explode and catch fire causing death or severe burns.**

**Do not use or store flammable products such as gasoline, solvents or adhesives in the same room or area near the water heater.**

**Keep flammable products:**

1. far away from heater,
2. in approved containers,
3. tightly closed and
4. out of children's reach.

**Water heater has a main burner:**

1. which may come on any time and
2. will ignite flammable vapors.

**Vapors:**

1. cannot be seen,
2. are heavier than air,
3. go a long way on the floor and
4. can be carried from other rooms to the pilot flame by air currents.

**Installation:**

**Do not install water heater where flammable products will be stored or used unless the main burner and pilot flames**

**area at least 18" above the floor. This will reduce, but not eliminate, the risk of vapors being ignited by the main burner or pilot flame.**

**Read and follow water heater warnings and instructions. If owners manuals is missing, contact the retailer or manufacturer.**

Fig. 2

## 2 Appliance details

### 2.1 Features

- Burner output proportional to hot water flow demand for maximum energy efficiency
- Stainless steel burners with stabilized blue flame
- Built-in corrosion resistant draft diverter
- Adjustable water flow restrictor to ensure that water flow demand will not exceed the heating capacity of the heater
- Safety thermocouple at pilot burner
- Automatic overheating protection shut-off sensor
- Copper heating coils for endless supply of hot water
- Easily removable one-piece cover
- Easy one person installation
- Easy Pilot Flame Ignition with push button piezo ignition.



BOSCH is constantly improving its products, therefore specifications are subject to change without prior notice.

---

### 2.2 AQ125 BO specifications (Technical data)

Approved in US/Canada

#### Capacity

Maximum flow rate: 3.7 GPM (14 l/min) at a 45°F (25°C) rise.

#### Maximum output

101,772 Btu/h (29.8 kW)

#### Maximum input

117,000 Btu/h (34.3 kW)

#### Efficiency in %

Recovery efficiency 80%

#### Min. Output

28,000 Btu/h (8.2 kW)

#### Gas Requirement

Gas connection (inches) - 3/4"

Inlet gas pressure under maximum operation\*

- Propane: 10.5" - 14" water column
- Natural Gas: 5.7" - 14" water column.

\* To measure Gas Pressure, see Measuring Gas Pressure, chapter 3.6.

#### Water

- Hot water connection (inches) - 1/2"

- Cold water connection (inches) - 1/2"
- Water valve material: Polymer (PPS) (Polypropylene Sulfid)
- Minimum water flow: 0.5 gallon/minute (1.9 l/m)
- Minimum recommended water pressure: 30 PSI (2.07 bar)
- Connections:
  - Bottom of heater

#### Dimensions

- Depth (in): 10.5" (265 mm)
- Width (in): 18.25" (460 mm)
- Height (in): 36.75" (936 mm)
- Weight: 64 pounds (29 kg).

#### Gas types

Natural Gas.  
LP Gas

#### Safety devices

- Flame failure device (ionization flame rod sensor)
- Pressure relief valve (supplied with heater)
- Over heat prevention (temperature limiter).

#### Water resistant

IP X5 (protection against water drops).

## 2.3 Unpacking the AQ-125-BO heater

This heater is packed securely.

**Before installing the unit, be certain you have the correct heater for your type of Gas - Propane or Natural Gas.** Identification labels are found on the shipping box, and on the rating plate which is located on the right side panel of the cover.

The box includes:

- Pressure relief valve
- Heat shield
- Mounting screws
- Product registration card
- Installation manual.

**Do not lose this manual, there is a charge for a replacement.**

Please complete and return the enclosed product registration card.

**The AQ125 BO is not approved or designed for:**

- Manufactured (mobile) homes, RV's or boats
- Heating or other recirculating/pumping applications\*
- Solar/preheat backup or high temperature booster use

\* This includes domestic hot water circulator pump loop systems that may previously exist in a home hot water system. The use of a small electric mini-tank (4-6 gallon size) should be used for this application; when designed so the pump will circulate the hot water in the mini-tank only and through the building's hot water return loop (timed or thermostatic controlled operation of the pump is commonly done). The AQ125 BO should be plumbed in line before the mini-tank water heater, contact BBTNA if further instruction is needed.

## 2.4 General rules to follow for safe operation

- ▶ **1.** You should follow these instructions when you install your heater. In the United States: The installation must conform with local codes or, in the absence of local codes, the National Fuel Gas Code ANSI Z223.1/NFPA 54.  
In Canada: The Installation should conform with CGA B149.(1,2) INSTALLATION CODES and /or local installation codes.
- ▶ **2.** Carefully plan where you install the heater. Proper clearances must be followed.
- ▶ **3.** The appliance must be isolated from the gas supply piping system by closing its individual manual gas shutoff valve (not supplied with heater) during any pressure testing at pressures in excess of ½ Psig (3.5 kPa).  
The appliance and its gas connection must be leak tested before placing the appliance in operation.
- ▶ **4.** Keep water heater area clear and free from combustibles and flammable liquids. Do not locate the heater over any material which might burn.
- ▶ **5. Correct gas pressure** is critical for the optimum operation of this heater. Gas piping must be sized to provide the required pressure at the maximum output of the heater, while all the other gas appliances are in operation. Check with your local gas supplier, and see the section on connecting the gas supply.
- ▶ **6.** Should overheating occur or the gas supply fail to shut off, turn off the gas supply at the manual gas shut off valve, on the gas line. Note: manual gas shutoff valve is not supplied with the heater.
- ▶ **7.** Do not use this appliance if any part has been underwater. Immediately call a qualified service technician to inspect the appliance and to replace any part of the control system and any gas control which has been underwater.

## 2.5 Dimensions and installation clearances

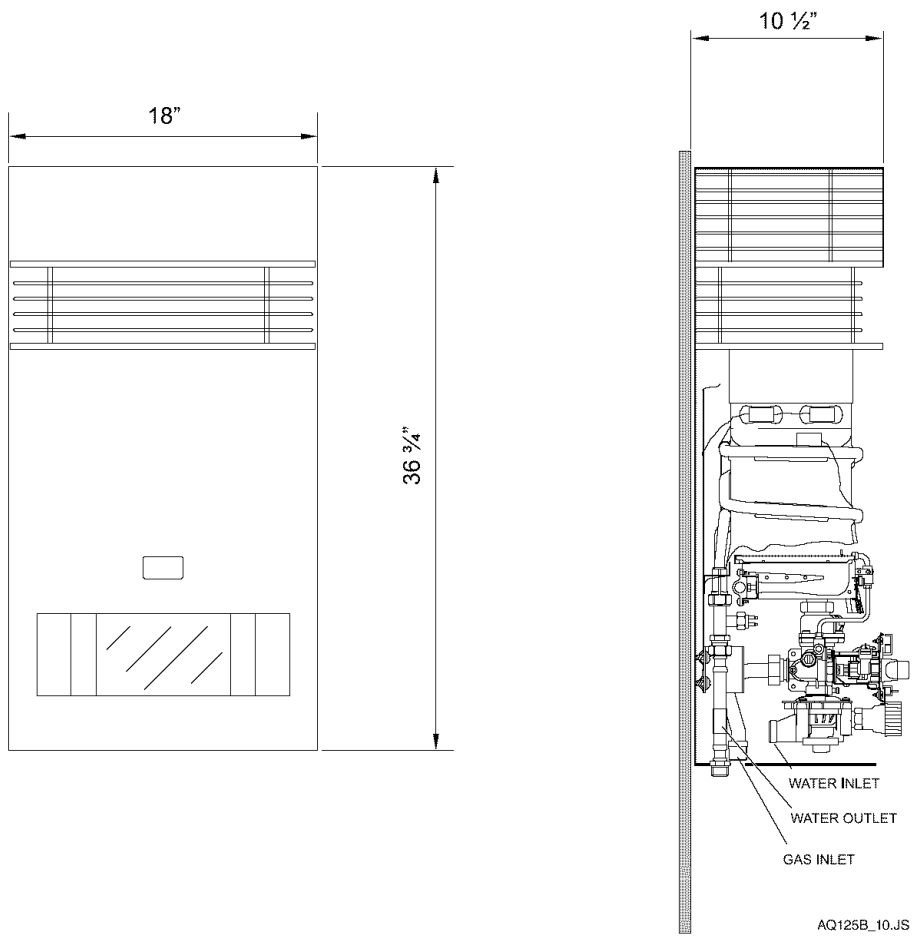

Fig. 3 Dimensions

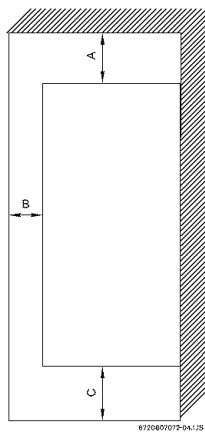

Fig. 4 Minimum clearances

	Model AQ125 B0
<b>TOP (A)</b>	3 ft.
<b>FRONT (B)</b>	4 ft.
<b>BACK</b>	0"
<b>SIDES</b>	4 ft.
<b>BOTTOM (C)</b>	1 ft.

Table 1 Minimum clearances

## 3 Installation instructions

### 3.1 Introduction

Please follow these instructions. Failure to follow instructions may result in:

- ▶ Damage or injury.
- ▶ Improper operation.
- ▶ Loss of warranty.

Please contact **BBT** North America with any questions.

### 3.2 Proper location for installing your heater

Carefully select the location of the water heater. Follow the guidelines below:

- ▶ **1.** Locate the heater where an adequate gas line size and plumbing connections are feasible and convenient.
- ▶ **2.** The hot water lines should be kept short to save energy. Centrally locating the water heater is best. It is always best to have hot water lines insulated to prevent the possibility of any freeze damage.
- ▶ **3.** The water in this heater is cold and always remains cold except for the times that hot water is being used. The heater is equipped with freeze prevention equipment that will operate and prevent freezing of the water in the heater to 5°F with no wind chill. Electrical power must be maintained to the heater to allow this to function.



**WARNING:** Proper insulation of the water lines below the heater is required if below freezing temperatures, below 32°F, are ever anticipated!



**Danger:** If the temperature drops below 32°F, freeze damage to the water heater itself must be prevented by turning off the power to the heater, then disconnecting the plumbing connections, as well as removing the drain plug and introducing short bursts of compressed air (20-40 psi) through the heater's connections. This will remove the residual water in the horizontal pipes and water valve.



**Danger:** Keep children away as the top of the water heater vent cap will get very hot during operation. Install in a place that prevents the top of the heater being reached by small children.



**Danger:** Flue gases will be released through the vent cap. Flue gas is very hot and contains carbon monoxide. The heater cannot be installed indoors. To prevent risk of fire and poisoning by carbon monoxide, assure all clearances indicated in manual.



**Danger:** Surface temperature around vent cap is less than 140°F, except highest top surface of vent cap may reach 300°F.



**Danger:** Do not place or store any combustible material within 5 feet of the appliance. Risk of fire could be caused by hot flue gas.



**Warning:** Flammable materials, gasoline, pressurized containers, or any other items or articles that are potential fire hazards must NOT be placed on or adjacent to the heater. The appliance area must be kept free of all combustible materials, gasoline and other flammable vapors and liquids.

### 3.3 Heater placement and clearances

The AQ125 BO is design certified for installation directly on a combustible wall. (see 3.4 Mounting installation). For installation on vinyl siding see Fig. 7. Keep the area below the heater free of combustible material.

#### Minimum clearances

If the appliance is installed under an overhang, there must be a 36" clearance from the top of the appliance and the mounting area must be open in front and on the sides of the appliance.

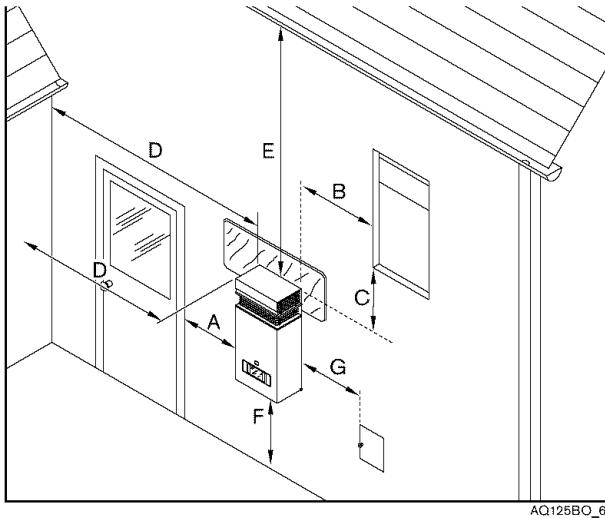

Fig. 5

**Danger:** The top of the kit will get hot due to the flue gases. Install away from children.

Ref.	Description	Min. distances
A	Directly below or from an opening; operable windows, doors and any fresh air openings	≥ 4 ft
B		
C		
D	From any adjacent wall or tall shrubbery	≥ 4 ft
E	Below a gutter, sanitary pipework, eaves or overhang	≥ 3 ft
F	Above ground	≥ 1 ft
G	From a gas meter, gas regulator, electrical box or another 125 BO heater.	≥ 3 ft

Table 2 Clearances

### 3.4 Mounting installation

**Warning:** before starting installation:

- ▶ check that there are no loose parts inside the appliance
- ▶ ensure that gas pipe, gas valve, and burner have no damage and are properly fitted.

**i** Front cover should be removed in order to inspect components visually (see instructions below).

To remove front cover.

- ▶ Loosen the two screws located on the sides of the front panel, see Fig. 6.

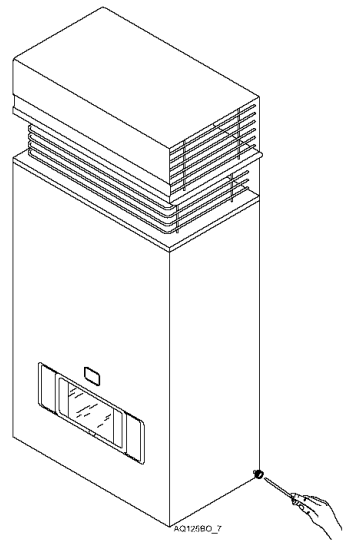

Fig. 6 Remove front cover

- ▶ Ensure that the flue terminal is clear of any combustible material.
- ▶ After inspection, replace front cover and tighten screws.
- ▶ Install only on an external wall, as close as possible to the most frequently used hot tap (note clearances in chapter 3.3).
- ▶ If the unit is to be installed on a combustible surface use the enclosed heat shield (see Fig. 5).

**Warning:** Do not mount heater directly to vinyl siding. With vinyl siding surfacing, a 6' x 4' area of the siding must first be covered or replaced with wood or other non-plastic made material. See Fig. 7.

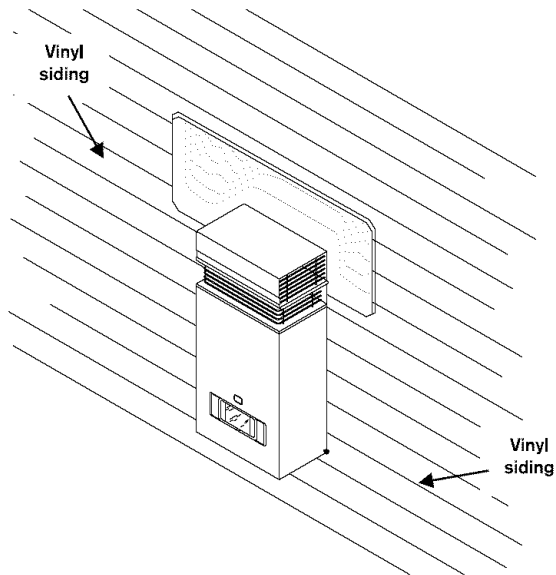

Fig. 7

- ▶ Secure heater to wall using enclosed mounting screws. Use mounting template for proper screw location.
- ▶ Locate head of screw in the key hole of the top mounting bracket.

### Vent Safety System

The AQ125 BO will shut down if the intake or exhaust louvers on the vent cap are blocked for any reason; see troubleshooting section on page 17.

### 3.5 Gas piping & connections



Before connecting the gas supply, check the rating plate on the right side of the heater to be sure that the heater is rated for the same gas to which it will be connected.

In the United States: The installation must conform with local codes or, in the absence of local codes, the National Fuel Gas Code ANSI Z223.1/NFPA 54.

In Canada: The Installation should conform to CGA B149 INSTALLATION CODES and/or local installation codes.

**Note:** The 125 BO comes with a gas pressure regulator installed. Disconnecting or altering the gas pressure regulator will be a violation of CSA certification of the unit. The regulator supplied with the heater is preset for the gas shown on the rating plate to the correct pressure. It is an appliance level regulator designed for (low inlet) pressure (less than 1/2 Psig or 14" W.C.).



**Warning:** DO NOT connect to an unregulated or high pressure propane line or to a high pressure commercial natural gas line.



**Warning:** The heater must be isolated from the gas supply piping system during any pressure testing of that system at test pressures equal to or more than 0.5 psig. If overpressure has occurred, such as through improper testing of the gas lines or malfunction of the supply system, the gas valve must be checked for safe operation.

#### GAS CONNECTIONS

- ▶ Install a manual gas shut off valve, on the gas supply line.
- ▶ Install a union when connecting gas supply.
- ▶ The minimum diameter required for any appliance connector used is 3/4".
- ▶ National Fuel Gas Code requires that a sediment trap (drip leg) be installed on gas appliances not so equipped. The drip leg must be accessible and not subject to freezing conditions. Install in accordance with the recommendations of the serving gas supplier.

When connections are made, check for gas leaks at all joints. Apply some gas leak detection solution to all gas fittings. Bubbles are a sign of a leak. A combustible gas detector may also be used to detect for leaks.



**Danger:** If you have a leak, shut off the gas. Tighten appropriate fittings to stop leak. Turn the gas on and check again with a gas leak detection solution. Never test for gas leaks using a match or flame.

#### HIGH ALTITUDE INSTALLATION

The pressure regulator provided with the heater is adjusted to deliver the proper gas pressure (as indicated on the rating plate and in the manual for altitude up to 2000 feet (660 meters) above sea level. On appliances being installed above 2000 ft (660 meters) elevation, the inlet gas pressure should be set at installation to the value shown below.

**Note:** The gas pressures specified below refer to pressures taken at the pressure tap on the gas inlet pipe just above the regulator. See chapter 3.6 for measuring gas pressure.

#### MAXIMUM INLET GAS FLOW PRESSURE SETTING

Altitude	Nat. Gas inches W.C.	Liquid Propane inches W.C.
0' - 2 000 ft	5.7"	10.5"
2 000 ft - 4 500 ft	4.6"	8.4"

Table 3 Above 4,500 ft consult your local gas provider

#### GAS LINE SIZING

The gas supply piping should be sized according to the applicable code for a maximum draw of 117,000 BTUH. Measure the length of gas supply line and use the tables in Fig. 9 or the gas line manufacturer's sizing tables to determine the pipe diameter necessary to accommodate the BTU demand of the unit. If there are more gas drawing appliances on the line, size the gas line according to the total maximum amount of BTU draw for all appliances.

**Note:** Under sizing the gas line may result in diminished output and improper operation. See chapter 3.6 for the procedure to confirm gas pressure.

**FOR NATURAL GAS**

Maximum Capacity of pipe in Cubic Feet of Gas per Hour for Gas Pressure of 0.5 Psig or less and a Pressure drop of 0.3 in Water Column (0.75mbar).(Based on a 0.60 Specific Gravity Gas) Btu numbers given in thousands. Copper tubing is prohibited for use with Natural Gas in the Commonwealth of Massachusetts and not recommended elsewhere.

Follow boxed numbers for piping just one AQ125 BO (example: 3/4" B.I. Natural Gas pipe for 20 ft (6.1m). will handle 190,000 btu's (55.7 kWh). For multiple appliances combine the total btu input load and then refer to applicable chart below.

Nominal Iron Pipe Size inches	Internal Diameter inches	Length of Black Iron Pipe, Feet															
		10	20	30	40	50	60	70	80	90	100	125	150	175	200		
1/4	0.364	32	22	18	15	14	12	11	11	10	9	8	8	7	6		
3/8	0.493	72	49	40	34	30	27	25	23	22	21	18	17	15	14		
1/2	0.622	132	92	73	63	56	50	46	43	40	38	34	31	28	26		
3/4	0.824	278	190	152	130	115	105	96	90	84	79	72	64	59	55		
1	1.049	520	350	285	245	215	195	180	170	160	150	130	120	110	100		
1 1/4	1.380	1050	730	590	500	440	400	370	350	320	305	275	250	225	210		
1 1/2	1.610	1600	1100	890	760	670	610	560	530	490	460	410	380	350	320		
2	2.067	3050	2100	1650	1450	1270	1150	1050	990	930	870	780	710	650	610		

Tube size, inches	EHD*	Length of Flexible Corrugated Stainless Steel Tubing (CSST), Feet					
		10	20	30	40	50	60
1/2	18 EHD	82	58	47	41	37	34
3/4	23 EHD	161	116	96	83	75	68
1	30 EHD	330	231	188	162	144	131
1 1/4	37 EHD	639	456	374	325	292	267

\* EHD = Equivalent Hydraulic Diameter. The greater the value of EHD, the greater the gas capacity of the tubing.

**FOR LP GAS**

Maximum Capacity of Pipe in Thousands of BTU per Hour of Undiluted Petroleum Gases (at 11 inches Water Column Inlet Pressure) (Based on a Pressure Drop of 0.5 Inch Water Column).

\* EHD = Equivalent Hydraulic Diameter. The greater the value of EHD, the greater the gas capacity of the tubing.

Nominal Iron pipe size inches	Black Iron Pipe Length of pipe, Feet														
	10	20	30	40	50	60	70	80	90	100	125	150			
1/2	275	189	152	129	114	103	96	89	83	78	69	63			
3/4	567	693	315	267	237	217	196	185	173	162	146	132			
1	107	732	590	504	448	409	378	346	322	307	275	252			
1 1/4	220	149	121	103	913	834	771	724	677	630	567	511			
1 1/2	330	229	185	155	141	127	118	108	102	976	866	787			
2	622	433	346	299	264	239	220	204	192	1811	1606	1496			

Tube size inches	EHD*	Length of Flexible Corrugated Stainless Steel Tubing (CSST), Feet					
		10	20	30	40	50	60
1/2	18 EHD	129	91	74	64	58	53
3/4	23 EHD	254	183	151	131	118	107
1	30 EHD	521	365	297	256	227	207
1 1/4	37 EHD	971	661	528	449	397	359

Maximum Capacity of Semi-Rigid copper Tubing in Thousands of BTU per Hour of Undiluted Liquefied Petroleum Gases (at 11 inches Water Column Inlet Pressure).

(Based on a Pressure Drop of 0.5 Inch Water Column)

\* Source National Fuel Gas Code NFPA 54, ANSI Z223.1 - No Additional Allowance is necessary for an ordinary number of fittings

Outside diameter Inch	Copper (LP gas only) Length of Tubing, Feet									
	10	20	30	40	50	60	70	80	90	100
3/8	39	26	21	19	-	-	-	-	-	-
1/2	92	62	50	41	37	35	31	29	27	26
5/8	199	131	107	90	79	72	67	62	59	55
3/4	329	216	181	145	131	121	112	104	95	90

Fig. 8

### 3.6 Measuring gas pressure

#### Connecting manometer

- ▶ Shut off gas.
- ▶ Remove front cover and locate inlet gas pressure measuring point on the right side of the gas valve.
- ▶ Loosen screw from test point on the left side of gas valve and connect manometer tube on test point.

#### Static pressure test

- ▶ Turn gas supply back on.
- ▶ Operate all other gas appliances on same gas piping system at maximum output.
- ▶ Record static gas pressure reading on back page of manual.

#### Operating pressure test

- ▶ Run high hot water flow rate.
- ▶ Set flow control knob fully clockwise.
- ▶ Set slide control to the right.
- ▶ Record operating gas pressure reading on back page of manual.

Gas pressures lower than 5.7" W.C. for Natural Gas or 10.5" W.C. for LP Gas will result in insufficient degree rise to the hot water being used, and must be corrected. See Gas Line Sizing under chapter 3.5.

### 3.7 Water connections



When facing the heater, the 1/2" cold water inlet is on the bottom right and the hot water outlet is on the bottom left.

▶ **INSTALL A UNION WHEN CONNECTING WATER PIPE TO FACILITATE ANY NECESSARY CLEANING AND SERVICING.**

Although water piping throughout your structure may be other than copper, we recommend that copper piping or suitably rated stainless steel flex line piping be used for at least three feet before and after the heater (follow local codes if more stringent). Never sweat any rigid piping directly to or beneath the water connections, damage can occur to the internal water valve from heating of the pipe. Plastics or other PEX type plumbing line materials are not recommended for connecting directly to the water heater. Keep water inlet and outlet pipes to no less than 1/2" (12.7mm) diameter to allow the full flow capacity.

**It is recommended that all water piping below the heater be properly insulated to avoid heat loss.** If below freezing temperatures are ever anticipated where the heater is located, insulation material is required and must be capable of protecting the piping from freezing. The freeze protection provided with the heater will not prevent any freeze damage to the exterior water piping. If the cold and hot connections to the heater are reversed, the heater will not function. Be certain there

are no loose particles or dirt in the piping. Blow out or flush the lines before connecting to the water heater. Full port valves should be installed on both the cold water supply and hot water outlet lines to facilitate servicing the heater (see Fig. 9). For installation on a private well system with the use of a pressure tank, the lowest pressure range setting recommended is 30-50 psi (2.07 and 3.45bar).

#### Connecting the pressure relief valve (PRV)

A listed pressure relief valve supplied with the heater must be installed at the time of installation. No valve is to be placed between the PRV and the heater. No reducing coupling or other restriction may be installed in the discharge line. The discharge line must be a minimum of 4" above a drain and installed such that it allows complete drainage of both the PRV and the line. The location of the PRV must be readily accessible for servicing or replacement, and be mounted as close to the water heater as possible. See Fig. 9. To install the PRV, a suitable fitting connected to an extension on a "T" fitting can be sweated to the hot water line. Support all piping.

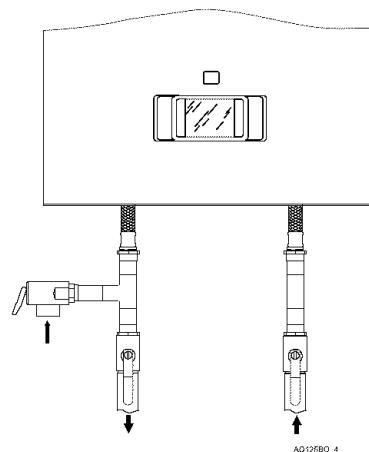

Fig. 9 Plumbing Connections and Pressure Relief Valve

### 3.8 Electrical connections



**Warning:** Confirm that the water heater is appropriately grounded and that the installation meets all electrical codes. Outdoor electrical outlets have special requirements.



**Warning:** For safety reasons, disconnect the power supply to the heater before any service or testing is performed.



**Warning:** This heater must be electrically grounded in accordance with the most recent edition of the National Electrical Code, NFPA 70. In Canada, all electrical wiring to the heater should be in accordance with local codes and the Canadian Electrical Code, CSA C22.1 Part 1. Do not rely on the gas or water piping to ground the metal parts of the heater.

The 125 BO requires an electrical power supply from a 120VAC 60Hz circuit and must be properly grounded. A means for switching off the 120VAC power supply must be provided.



**Warning:** The heater is equipped with freeze prevention equipment that will operate and prevent freezing of the water in the heater to 5°F with no wind chill. Electrical power must be maintained to the heater to allow this to function. **WARNING: Proper insulation of the water lines below the heater is required if below freezing temperatures, below 32°F, are ever anticipated.**

## 4 Operation instructions

### 4.1 For your safety read before operating your water heater



**Warning:** If you do not follow these instructions exactly, a fire or explosion may result causing property damage, personal injury or loss of life.

**A.** This appliance employs a piezo-igniter to light the pilot burner. When lighting the pilot, follow these instructions exactly.

**B.** What to do if you smell gas.



#### WHAT TO DO IF YOU SMELL GAS

- ▶ Do not try to light any appliance.
- ▶ Do not touch any electric switch; do not use any phone in your building.
- ▶ Immediately call your gas supplier from a neighbors phone. Follow the gas supplier's instructions.
- ▶ If you cannot reach your gas supplier, call the fire department.

**C.** Use only your hand to push in the gas control buttons. Never use tools. If a button will not push in, check to make sure the buttons are being pushed in the proper sequence. Follow these instructions exactly. If control button(s) are jammed, close the heater's individual manual shutoff valve and call a qualified service technician. Forced or attempted repair may result in a fire or explosion.

**D.** Do not use this appliance if any part has been under water. Immediately call a qualified service technician to inspect the appliance and to replace any part of the control system and any gas control which has been under water.

### 4.2 Lighting instructions

- ▶ **1.** STOP! Read the previous safety information.
- ▶ **2.** The gas valve must be turned off by sliding the gas valve button to all the way to the left.
- ▶ **3.** Wait five (5) minutes to clear out any gas. If you smell gas, STOP! Follow "B" in the safety information above on this plate. If you don't smell gas, go to next step.
- ▶ **4.** The pilot burner is located behind the peephole in the front center of the cover directly below this instruction plate.
- ▶ **5.** Open the sliding viewer window.
- **6.** Slide the gas valve button to the right, under the mark .
- **7.** Fully depress gas valve button and light pilot by pushing the button marked . This step may have to be repeated.

- ▶ **8.** Observe the pilot flame through the peephole. The gas valve button should be held down for at least 15 seconds with pilot burning. When the gas valve button is released, the pilot should continue to burn.

- If the gas valve button does not pop up when released, stop and immediately call your service technician or gas supplier.

- If pilot does not stay lit, repeat steps 1 through 8.

- If pilot will not stay lit after several tries, slide the gas valve button all the way to the left and call service technician or gas supplier.

- ▶ **9.** Once pilot remains lit, release the gas valve button. The heater will now fire at minimum power when water is drawn at a rate greater than the threshold flow rate.

**Note:** If main burner should fail to ignite, make sure pilot is burning. If not, repeat lighting steps 1 through 8.

**Note:** The 125BO operates in two modes. See SETTING THE WATER TEMPERATURE.



**Note:** On first time initial installation, existence of air in the gas supply line and in the water line may cause some ignition delay. In that case, repeat the ignition process until all the air has been purged.

### 4.3 To turn off appliance

- ▶ Slide the gas valve button all the way to the left and turn off the manual gas valve on the supply line to the heater.

### 4.4 Setting the water temperature

The 125 BO has a gas control that modulates burner input in response to flow. Its purpose is to ensure that the hot water temperature will remain steady, although the water flow demand might vary. The output temperature can be adjusted with either the temperature adjustment knob or the gas control slide.

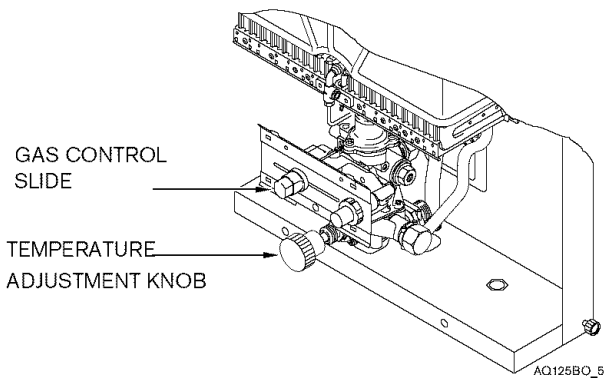

Fig. 10 Temperature Adjustment Controls

**Temperature adjustment knob**

The temperature adjustment knob on the front bottom of the heater (see Fig. 10) adjusts temperature by adjusting flow capacity. See table 4 for details.

Knob position	clockwise	counter-clockwise
Degree rise	90°F	45°F
Activation rate	0.5 GPM	1.1 GPM
Max flow rate	2.0 GPM	3.7 GPM

Table 4 Clearances

As the temperature adjustment knob is turned counter-clockwise, the output temperature will lower and the activation rate will be raised. Turning the knob clockwise will raise the temperature and lower the activation rate.

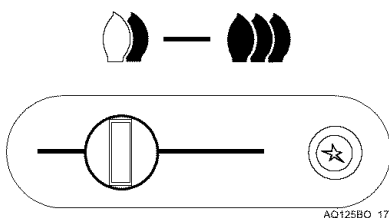

Fig. 11

**Gas control slide button**

The gas control slide button adjusts temperature by adjusting how much gas is allowed to flow to the burners.

As the slide is adjusted to the left, the output temperature will lower, with the lowest setting being the one flame position (🔥). The hottest position is the three flame position all the way to the right (🔥🔥🔥).

## 5 Maintenance and service

### 5.1 Maintenance intervals

The 125 BO requires periodic maintenance. The below time maintenance intervals should be kept to ensure the unit is operating for many years.

#### Every year

- ▶ Inspect inlet water filter screen ( 5.2)
- ▶ Inspect pilot assembly and flame ( 5.3)
- ▶ Inspect burner assembly ( 5.4)

#### Every 2 years

- ▶ Lubricate and clean water valve ( 5.2)

#### Every 3 to 5 years

- ▶ Rebuild water valve ( 5.2)
- ▶ Clean pilot assembly and clean or replace orifice ( 5.3)

### 5.2 Water valve

The water valve is the main control that tells the heater to fire. If the periodic maintenance is neglected, more costly damage may occur over time.

#### Inspecting inlet water filter screen

Shut off the installer supplied cold water supply valve. Disconnect water pipe going to the back of the water valve. Remove filter from back of water valve. Clean the filter and inspect for damage. Replace if the filter is at all damaged. Inspect the top of the water valve for signs of a water leak or corrosion. If present, rebuild the water valve. (See below).

#### Lubricating the water valve

A more detailed instruction is available on our website at [www.boschhotwater.com](http://www.boschhotwater.com). Shut off all water to the unit and disconnect water pipe going to the back of the water valve. Disconnect water pipe going to heat exchanger by removing pin and pulling pipe out. Loosen two set screws at the base of the gas valve and drop the water valve down. Separate the two halves by removing 5 screws on the top of the water valve. Apply lithium or faucet and valve grease to the pushrod (see Fig 13, pos. 23). Inspect and clean the venturi (see Fig 13, pos. 29).

#### Rebuilding the water valve

Several parts within the water valve should be replaced every 3-5 years. The parts list and instruction can be found on our website at [www.boschhotwater.com](http://www.boschhotwater.com).

### 5.3 Pilot

#### Inspecting pilot

The pilot should burn with a clean sharp blue flame. The flame should fully envelope the bend of the flame sensor rod. If it does not, clean the pilot assembly per procedure below.

#### Cleaning pilot assembly

Disconnect the flame sensor rod cable and the igniter cable by pulling gently down. Remove two screws holding pilot assembly in place. Loosen compression fitting and remove pilot assembly. **Note:** The orifice sits on top of the compression fitting DO NOT LOSE. Polish flame sensor rod and igniter tip with emery cloth. Clean out pilot assembly and orifice with carburetor cleaner. If heater is an LP unit, replace orifice. **Caution:** Do not enlarge orifice.

### 5.4 Main burners

The main burner flames should be blue, with a more intense blue cone in the center core. Yellow flames could be a sign of wrong size gas orifices or dirty burners, or a blockage on the heat exchanger fins. If some burners have yellow flames while others have good flames, it is likely that dust, lint or spider webs have partially clogged the burner venturis. To clean the burners, contact a gas service person.

### 5.5 Vent assembly

Inspect the draft hood and heat exchanger fins for signs of soot build-up or any other foreign material such as spider webs. Clean out any debris found in the vent hood. Signs of soot indicate insufficient combustion air or exhaust draft. Check for vent assembly blockage or combustion air blockage on the underside of the unit.

### 5.6 Mineral scale build-up

The 125 BO, when operated at lower temperature settings, does not accumulate mineral build-up. If however, the heater is used at the higher temperature settings and the water has a high mineral content, periodic descaling may be necessary. The heating coils should be flushed with a descaling solution. Consult your dealer or BBT North America for instructions. Consult your service person.

## 6 Troubleshooting

### 6.1 Introduction

Many of the questions customers ask regarding operation of this unit can be answered by following the troubleshooting steps as outlined below. Visit our web site at [www.boschhotwater.com](http://www.boschhotwater.com) for more detailed troubleshooting. For best results, perform each step before proceeding to the next. The suggested solutions may require that the cover be taken off. (See chapter 3.4).

### 6.2 Pilot will not light

- 1. If the unit was just installed or the gas lines have been worked on, there may be air in the gas line. To bleed air out of the gas line, hold down the gas valve button while hitting the piezo ignitor button  every second.
- 2. Check to make sure the manual gas shut off valve is in the open position. Have licensed gas technician or service person check the presence of gas at the gas pressure measuring tap on the left side of the gas control valve. If gas is not present, the regulator may be locked up and need replacing. See chapter 3.5 for required gas pressures.
- 3. Clean or replace the pilot orifice. See chapter 5.3 for instructions.

### 6.3 Pilot will light but not stay on when button released

- 1. When lighting pilot ensure the gas valve button is fully depressed and held down for at least 15 sec after pilot is lit.
- 2. Pilot flame should be blue in color and hitting the thermocouple tip. See chapter 5.3 for instructions.
- 3. Check the electromagnet connections. Electromagnet is located on the right side of the gas valve behind the piezo push-button assembly. The Electromagnet connection is a large aluminum 17mm hex head nut. The thermocouple end is a 5 mm brass nut which screws into the 17 mm nut. Tighten both nuts snugly but do not over tighten.
- 4. Check if connections at the ECO are loose or corroded. Clean any corrosion with very fine sand paper or an eraser and reconnect leads.
- 5. If cleaning the terminals attached to the ECO did not fix the problem, connect a jumper wire between the two wires attached to the ECO and try to relight the pilot. If the pilot flame now remains on, the ECO may be defective and need to be replaced. Do not leave jumper connected.
- 6. Have a licensed gas technician verify the proper operation of the thermocouple by measuring the

millivoltage from the thermocouple lead to ground. The expected reading is 24mVDC or greater.

### 6.4 Burners do not ignite with water flow

- 1. Verify the pilot is lit.
- 2. Turn temperature adjustment knob all the way clockwise. Turn hot water faucet to full on position and fill a quart container. If the container fills in 30 seconds or less your flow rate (1/2 gallon per minute) is sufficient to activate the heater. If the knob is full counter clockwise, the container will need to fill in 14 seconds (1.1 gallons per minute) to activate the heater. Check for restrictions in the water line such as clogged aerators or a clogged inlet water filter screen if flow rate is not sufficient.
- 3. Clean water inlet filter screen. See chapter 5.2.
- 4. Shut off installer supplied cold water supply valve (if none installed, install before proceeding). Open all hot water taps supplied by the 125 BO. Wait 5 minutes and check all taps. Water running is a sign of a plumbing cross-over. Consult a local plumber or service person for help in correcting plumbing cross-over.
- 5. Verify the cold water supply is connected to the right side of the heater.
- 6. Service the water valve. See chapter 5.2 for intervals and instructions.

### 6.5 Hot water temp fluctuates from hot to cold

- 1. Shut off installer supplied cold water supply valve (if none installed, install before proceeding). Open all hot water taps supplied by the 125 BO. Wait 5 minutes and check all taps. Water running is a sign of a plumbing cross-over. Consult a local plumber or service person for help in correcting plumbing cross-over.
- 2. Check for restrictions in the water line such as clogged aerators, clogged shower head or a clogged inlet water filter screen.
- 3. If hot water is so hot that a large amount of cold water must be introduced to lower temperature to comfortable level, lower output temperature. See chapter 4.4 for instructions.
- 4. Check the inlet water pressure. For installation on a private well system with the use of a pressure tank, the lowest pressure range setting recommended is 30-50 psi (2.07 - 3.45 bar). Confirm that the pressure tank is not water logged.

- 5. Service water valve See chapter 5.2 for intervals and instructions.
- 6. ECO (overheat sensor) tripped due to overheating re-ignite the appliance 10 minutes later. If it happens again, contact your service person.

### 6.6 Water is too hot

- 1. Check gas type on right side panel rating plate. NG is a natural gas unit and LP is for liquid propane.
- 2. Since the unit does not measure incoming water temperature, the output water may be warmer in the summer than in the winter. Use the slide control to lower output temperature as outlined in chapter 4.4.
- 3. Contact your service person if water temperature does not lower per procedure outlined in chapter 4.4.
- 4. Check the inlet water pressure. For installation on a private well system with the use of a pressure tank, the lowest pressure range setting recommended is 30-50 psi (2.07 - 3.45 bar). Confirm that the pressure tank is not water logged.
- 5. Service water valve See chapter 5.2 for intervals and instructions.
- 6. ECO (overheat sensor) tripped due to overheating period Re-ignite the appliance 10 minutes later. If it happens again, contact your service person.

### 6.7 Water is not hot enough

- 1. Adjust the temperature per chapter 4.4.
- 2. Shut off installer supplied cold water supply valve (if none installed, install before proceeding). Open all hot water taps supplied by the 125 BO. Wait 5 minutes and check all taps. Water running is a sign of a plumbing cross-over. Consult a local plumber or service person for help in correcting plumbing cross-over.
- 3. While the heater is running with full hot water flow, the flames should be 3-4" tall off the burner bed. If the flames are not this tall, have the gas pressure measured per chapter 3.6 by a license gas technician or your service person.
- 4. Service water valve See chapter 5.2 for intervals and instructions.

## 7 Interior components and diagram parts list

### 7.1 Interior components

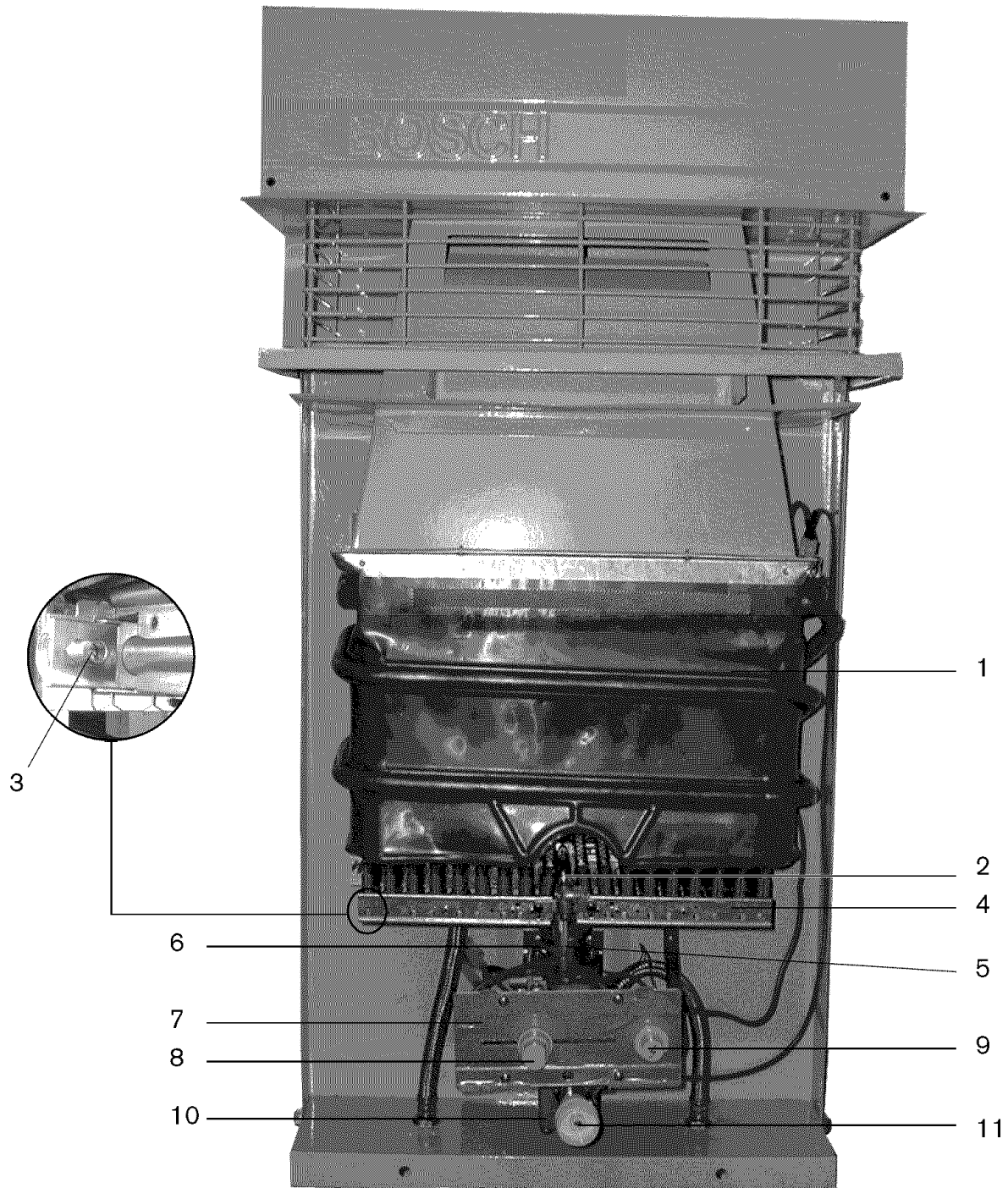

Fig. 12 Functional scheme

- |   |  |    |                                 |
|---|--|----|---------------------------------|
| 1 | Heat exchanger                           | 7  | Water valve                     |
| 2 | Pilot assembly                           | 8  | Gas control slide               |
| 3 | Burner manifold gas pressure test nipple | 9  | Electronic control box          |
| 4 | Main gas burner                          | 10 | Temperature adjustment selector |
| 5 | Pilot gas tubing                         |    |                                 |
| 6 | on/off switch                            |    |                                 |

## 7.2 Components diagram

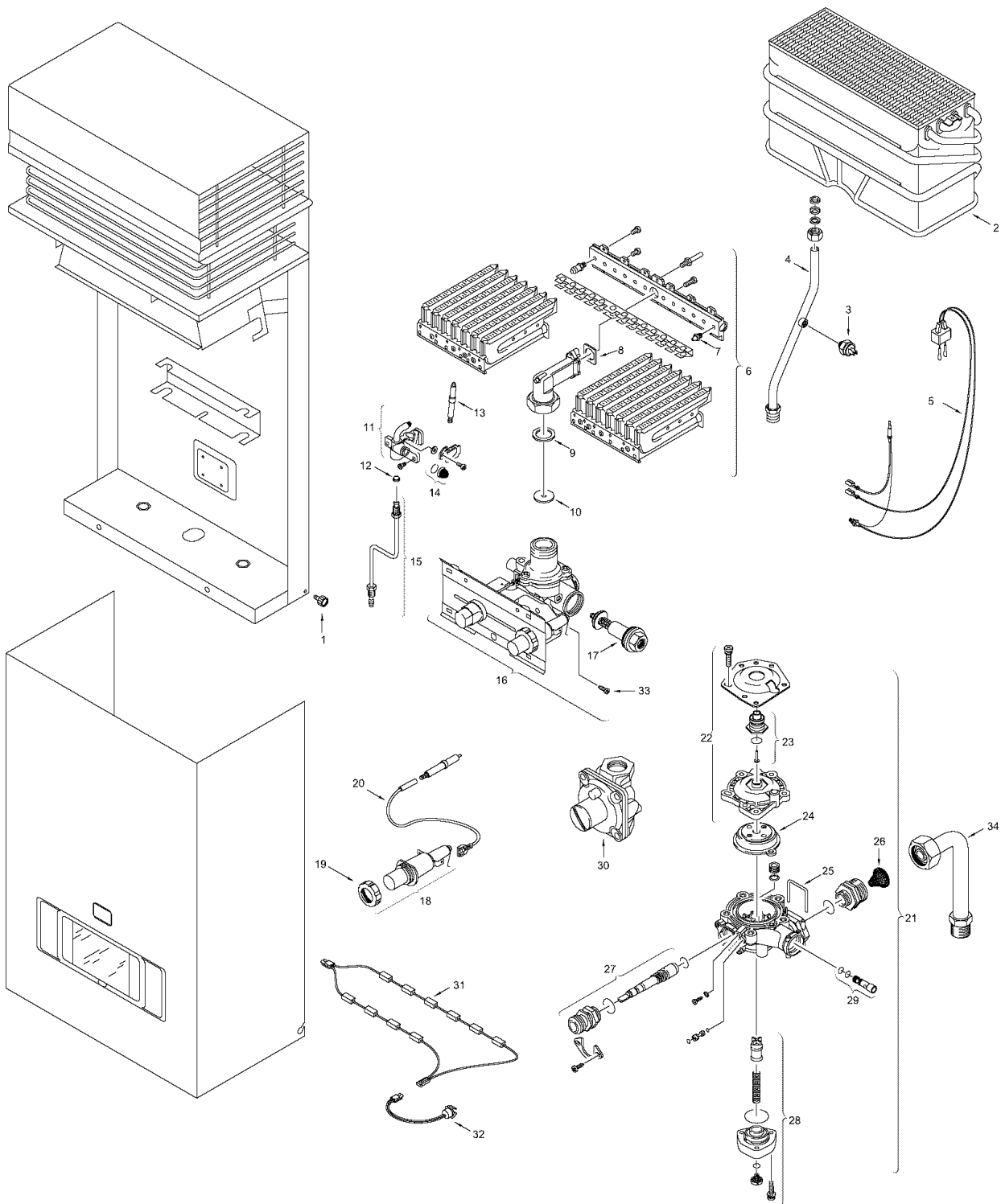

Fig. 13 Components Diagram

### 7.3 Parts list

Item	Description	Reference
1	Screw	8 716 461 314
2	Heat exchanger	8 705 406 235 0
3	Temperature limit	8 707 206 017 0
4	Hot water pipe	8 716 416 714
5	Thermocouple	8 707 202 087 0
6	Burner	8 708 120 298 0 (NG)
6	Burner	8 708 120 296 0 (LP)
7	Nozzle (120)	8 708 202 124 0 (NG)
7	Nozzle (79) (10x)	8 708 202 149 0 (LP)
8	Washer	8 701 003 010 0
90	Washer 1" (10x)	8 710 103 060 0
10	Throttle disc (7,0)	8 700 100 174 0
11	Pilot burner (41.1)	8 718 105 051 0
12	Pilot injector (5)	8 708 200 005 0 (NG)
12	Pilot injector (49)	8 748 200 173 0 (LP)
13	Sparking plug	8 708 107 002 0
14	Strainer	8 700 507 055 0
15	Pipe - Pilot gas	8 700 707 320 0
16	Gas valve	8 707 021 090 0 (NG)
16	Gas valve	8 707 021 091 0 (LP)
17	Magnetic unit	8 707 201 012 0
18	Piezo igniter	8 708 108 040 0
19	Nut	8 743 301 025 0
20	Cable	8 704 401 023 0
21	Water valve	8 707 002 708 0
22	Cover	8 705 500 101 0
23	Sleeve	8 700 306 114 0
24	Diaphragm (C)	8 700 503 053 0
25	Wire form spring	8 704 705 024 0
26	Water strainer	8 700 507 001 0
27	Selector Screw	8 708 500 289 0
28	Volumetric water governor	8 705 705 027 0
29	Venturi (23s)	8 708 205 279 0
30	Gas regulator	8 716 487 043 (LP)
30	Gas regulator	8 716 487 044 (NG)
31	Anti frost device	8 716 459 336
32	Thermostat	8 716 459 273
33	Screw	8 703 401 051 0
34	Cold water pipe	8 716 416 715

Table 5

## 8 Protecting the environment

### Packing

The packing box may be fully recycled as confirmed by the recycling symbol .

### Components

Many parts in the heater can be fully recycled in the end of the product life. Contact your city authorities for information about the disposal of recyclable products.

### Saving water resources:

- ▶ Make sure you close all the taps after any use. Avoid leaving the taps dripping. Repair any leaking tap.
- ▶ Define the temperature you want. This way you have the precise water flow needed (mixing cold water to regulate temperature will increase the water flow with consequent waste of water).

**For increased safety shut off the appliance from the main water supply if you are staying away from home for a considerable time.**

**At below freezing temperatures, disconnect the plumbing connections to the heater and allow the heater to drain.**

**To prevent any freeze damage, introduce short bursts of compressed air (20-40 psi) through these connections to remove the residual water in the horizontal pipes and water valve.**

## 9 Twelve Year Limited Warranty

### General

Aquastar water heaters are warranted by the Manufacturer (BOSCH) through **BBT** North America. **BBT** North America (BBTNA) will furnish a replacement heat exchanger and will furnish a replacement of any other part which fails in normal use and service within the applicable periods specified below, in accordance with the terms of this warranty. The BBTNA replacement will be warranted for the unexpired portion of the original warranty. This warranty will be valid only for water heaters in possession of the original purchaser as recorded on the warranty card.

### The Heat Exchanger

If the heat exchanger fails within twelve (12) years after the original installation and operation BBTNA will furnish a replacement heat exchanger. However, if the water heater is installed in other than a single family dwelling this heat exchanger warranty is limited to two (2) years from date of original installation and operation.

### Exceptions

This warranty will not apply:

- **1.** to defects or malfunctions resulting from failure to properly install, operate or maintain the unit in accordance with the printed instructions provided;
- **2.** to damage or abuse, accident, neglect or freezing and other acts of nature;
- **3.** to damage resulting from operation with either the flame sensor rod or overheat sensor removed;
- **4.** to failure of the heat exchanger resulting from the operation of the water heater in a corrosive atmosphere or at water temperatures exceeding the maximum rating, or if the water heater is not supplied with potable water;
- **5.** to defects or damage cause by any attachment or modification, including any energy-saving device.

### All Other Parts

If any other part fails within two (2) years after original installation and operation, BBTNA will furnish a replacement part free of charge.

### Shipping costs

In addition to supplying the replacement part(s), BBTNA will provide ground service delivery for these parts. Expedited or upgraded shipping will be charged to the customer.

### Service Labor Costs

This warranty does not cover any labor costs associated with service, removal or re-installation of part(s). All such costs must be borne by the Purchaser. Additionally, this warranty does not cover any labor

costs associated with service, removal or re-installation of the original water heater or a replaced water heater.



Note: the water heater must be free of damaging scale deposits and not subject to gas pressures greater than those shown on the rating plate, which must not be altered, defaced or removed.

### How to Make a Claim

Any claim for warranty parts should be made to your local dealer, distributor or to BBTNA. If BBTNA, please contact the Technical Support Department:

**BBT NORTH AMERICA**  
 Bosch Group  
 340 Mad River Park  
 Waitsfield, VT 05673  
 Phone: 800-642-3111  
[www.boschhotwater.com](http://www.boschhotwater.com)

In most cases, the dealer or distributor will be able to promptly honor your claim and subsequently notify BBTNA. However, all replacements are made subject to validation by BBTNA of in-warranty coverage. The damaged or defective item must be made available in exchange for the replacement.

### Miscellaneous

No one is authorized to make any other warranties on behalf of BBTNA. It is expressly understood that the replacement warranty of BBTNA shall be in lieu of any and all other warranties, express or implied, including warranties of merchantability or fitness for a particular use or purpose, and further that BBTNA shall not be liable for any loss or damage directly or indirectly arising from the use of the hot water heater, or for any consequential damages arising from such use (including damages from water leakage). BBTNA sole liability with respect to any defect shall be for the replacement of the defective part(s). Some states do not allow such limitations and exclusions, so the above may not apply to you.

This warranty gives specific legal rights. You may also have other rights which vary from state to state.

## Installer Checklist, to be performed by installer upon installation

Serial Number \_\_\_\_\_

(8 digit serial number is located on rating plate on right side panel)

Gas Pressure Reading\*

Static \_\_\_\_\_ Operating \_\_\_\_\_

Building Water Pressure \_\_\_\_\_

Range if on Well system \_\_\_\_\_

Average Winter Temperature \_\_\_\_\_

Average Summer Temperature \_\_\_\_\_

Installing Company \_\_\_\_\_

Installer name \_\_\_\_\_

Address \_\_\_\_\_

Phone \_\_\_\_\_

\* See Chapter 3.6 and gas pressure table (to be filled out by installer)

Installation manual should be left with the owner after the installation is tested and completed

Replacement Parts available from:

**BBT NORTH AMERICA**  
Bosch Group

Bosch Water Heating  
340 Mad River Park  
Waitsfield, VT 05673  
Phone 800-642-3111  
Fax (802) 496-6924  
www.boschhotwater.com  
techsupport@boschhotwater.com

VULCANO Termodomésticos S.A.  
Estrada de Cacia  
3801 - 856 Aveiro - PORTUGAL