

GWH-635-ES INDOOR MODEL

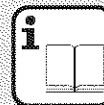

Temperature Modulated with Electronic Ignition

Suitable for heating potable water only - Not approved for space heating purposes
(Intended for variable flow applications)

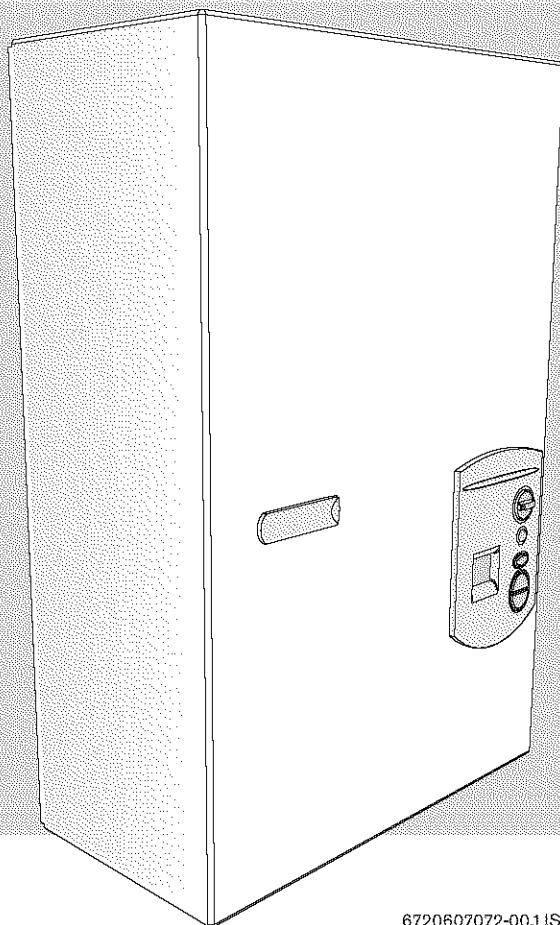

6720607072-00.1JS



BOSCH

ProTankless™



GWH-635-ES-N - Natural Gas GWH-635-ES-L - Liquefied Petroleum (LP) Gas

Warning: If the information in this manual is not followed exactly, a fire or explosion may result causing property damage, personal injury or death. Do not store or use gasoline or other flammable vapor and liquids in the vicinity of this or any other appliance.

Improper installation, adjustment, alteration, service or maintenance can cause injury or property damage. Refer to this manual. For assistance or additional information consult a qualified installer, service agency or the gas supplier.

In the Commonwealth of Massachusetts this product must be installed by a licensed plumber or gas fitter.

Upon completion of the installation, these instructions should be handed to the user of the appliance for future reference.

What to do if you smell gas

- Close gas valve. Open windows.
- Do not try to light any appliance.
- Do not touch any electrical switch; do not use any phone in your building.
- Immediately call your gas supplier from a neighbor's phone. Follow the gas supplier's instructions.
- If you cannot reach your gas supplier, call the fire department.
- Installation and service must be performed by a qualified installer, service agency or the gas supplier.



Index

1	Warning	2
2	Appliance details	4
2.1	Features	4
2.2	GWH-635-ES Specifications (Technical data)	4
2.3	Unpacking the GWH-635-ES heater	5
2.4	General rules to follow for safe operation	6
2.5	Dimensions and Minimum installation clearances	7
3	Installation instructions	8
3.1	Introduction	8
3.2	Proper location for installing your heater	8
3.3	Heater placement and clearances	8
3.4	Mounting installation	8
3.5	Combustion air requirements	9
3.6	Venting	11
3.6.1	Vent material and specifications	11
3.6.2	Vent connections	12
3.6.3	Condensate drain tube requirements	13
3.6.4	Room sealed installation (Twin pipe)	13
3.6.5	Vertical terminations	14
3.6.6	Horizontal terminations	15
3.6.7	Exhaust vent configuration examples	18
3.7	Gas piping & connections	19
3.8	Measuring gas pressure	21
3.9	Water connections	22
3.10	Electrical connections	23
3.11	Cascading function	23
3.12	Recirculation application	23
4	Operation instructions	24
4.1	For your safety, read before operating your water heater	24
4.2	Power	24
4.3	Temperature selection	25
4.4	Use of optional remote control accessory	27
4.5	Operation	27
4.6	Reset button	27
4.7	Program button	27
4.8	Locked condition	27
5	Maintenance and service	28
5.1	Annual maintenance	28
5.2	Winterizing for seasonal use	28
5.3	Mineral scale build-up	29
5.4	Adjusting CO2	29
5.5	Control board diagnostics	32
6	Troubleshooting	33
6.1	Introduction	33
6.2	Burners do not ignite when hot water is turned on	33
6.3	Water is too hot	33
6.4	Water is not hot enough	33
6.5	Low water flow/pressure	34
6.6	Hot water temperature fluctuates at tap	34
6.7	Noisy burner/heater during operation	34
6.8	Error code diagnostics	36
7	Electrical diagram	41
8	GWH-635-ES Functional scheme	42
9	Interior components diagram and parts list	43
9.1	Interior components	43
9.2	Components diagram	44
9.3	Parts list	45
10	Protecting the environment	46
11	Fifteen Year Limited Warranty	47

1 Warning

For your safety

Do not store or use gasoline or other flammable, combustible or corrosive vapors and liquids in the vicinity of this or any other appliance.



Warning: Carefully plan where you install the heater. Correct combustion air supply and flue pipe installation are very important. If a gas appliance is not installed correctly, fatal accidents can result from lack of air, carbon monoxide poisoning or fire.



Warning: Exhaust gas must be vented to outside using proper vent material suitable for category III vent systems and temperatures up to 480°F. Vent and combustion air piping must be sealed gas-tight to prevent possibility of flue gas spillage, carbon monoxide emissions and risk of fire, resulting in severe personal injury or death.



Warning: Place the heater in a location where water leaks will do **NO DAMAGE** to adjacent areas or lower floors.



Warning: Field wiring connections and electrical grounding must comply with local codes, or in the absence of local codes, with the latest edition of the National Electric Code, ANSI/NFPA 70, or in Canada, all electrical wiring must comply with the local codes and the Canadian Electrical Code, CSA C22.1 Part 1.



Warning: Shock hazard: line voltage is present. Before servicing the water heater, unplug power supply cord from outlet. Failure to do so could result in severe personal injury or death.



Warning: The heater must be disconnected from the gas supply piping system during any pressure testing of that system at test pressures equal to or more than 0.5 psig.

FCC:

This device complies with Part 15 of the FCC rules.

Operation is subject to the following two conditions: (1) This device may not cause harmful interference, and (2) this device must accept any interference received, including interference that may cause undesired operation.

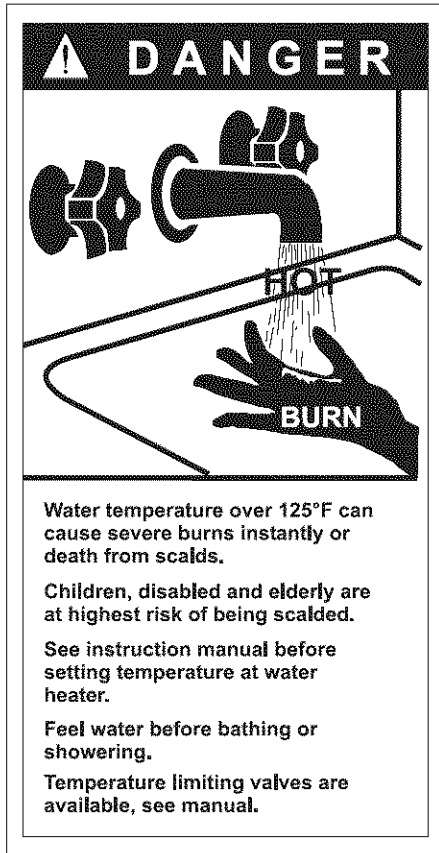

Fig. 1

2 Appliance details

2.1 Features

Parts

- Touch pad interface control
- High power pre-mix compact burner with low NOx emissions
- Modulating gas valve with constant gas to air ratio control
- Modulating water valve for improved comfort and temperature control.

Safety

- Flame sensor (ionization) rod
- Overheat sensor
- Temperature limiter
- Fan speed monitoring.

High quality materials for long working life

- Copper heat exchanger
- High efficiency Ceramat burner
- Compact space saver: mounts on a wall with a supplied bracket.
- Easily removable one-piece cover.

Features

- LCD Display
- On/Off and temperature control switches
- Reset button
- Program key (selectable temperature)
- Failure codes for easy diagnostics and repair
- Diagnostic mode for troubleshooting/informational purposes
- Cascading function.

Accessories

- Optional wireless remote control accessory to remotely set temperature (Part # TSTAT2) .
- Tankless Link: Allows two GWH-635-ES heaters to be linked together for double the hot water volume (Part # TLINK) .
- Horizontal vent termination kit (Part # 4TWHVK3S) .



BOSCH is constantly improving its products, therefore specifications are subject to change without prior notice.

2.2 GWH-635-ES Specifications (Technical data)

Approved in US/Canada

Capacity

Maximum flow rate: 6.35 GPM (24 l/min) at a 45°F (25°C) rise.

Maximum output

142,968 Btu/h (41.8 kW)

Maximum input

175,000 Btu/h (51.2 kW)

Efficiency in %

Recovery efficiency 86.5%

Min. Output

31,131 Btu/h (9.1 kW)

Temperature Control

Selection range: 100°F (38°C) - 140°F (60°C)

Default temperature: 122°F (50°C)

Stability: +/- 2°F (+/- 1°C)

Gas Requirement

Gas connection (inches) - 3/4" NPT

Inlet gas pressure under operation (with a high hot water flow rate)*

- Propane: 11" - 14" water column
- Natural Gas: 5" - 14" water column.

* To measure gas pressure, see Measuring gas pressure, chapter 3.8.

Venting

A condensate trap is integrated into the exhaust flue gas collar of the heater, the supplied condensate drain tube **MUST** be installed to it for proper removal of condensate from the trap. Additional condensate traps and drains may be necessary; see chapter 3.6 for Venting.

Water

- Hot water connection (inches) - 3/4" NPT
- Cold water connection (inches) - 3/4" NPT
- Water valve material: Polymer (PPS) (Polypropylene Sulfid)
- Minimum water flow for activation: 0.8 gallon/minute (3 l/m)
- Minimum recommended water pressure: 30 PSI (2.07 bar)
- Connections:
 - Bottom of heater

Combustion

- NOx ≤ 55 ppm
- CO ≤ 300 ppm

- CO₂ level set from factory, see chapter 5.4.

Dimensions

- Depth (in): 8 1/2" (220 mm)
- Width (in): 15 3/4" (400 mm)
- Height (in): 23 1/2" (600 mm)
- Weight: 47 pounds (21 kg).

Gas types

Natural Gas.

LP Gas.

Converting the gas type can only be done by a certified gas technician with a calibrated CO₂ analyzer.

Call Bosch Water Heating for conversion information.

Voltage

120 V AC (50/60 Hz)

6 ft power supply cord

Amperage

Idle - 40 mA

Operation - ≤ 2.5 A

Noise

≤ 50 db (A)

Safety devices

- Flame failure device (ionization flame rod sensor)
- Pressure relief valve (supplied with heater)
- Over heat prevention (temperature limiter).

Water resistant

IP X4 (protection against water drops)

2.3 Unpacking the GWH-635-ES heater

Before installing the unit, be certain you have the correct heater for your type of Gas - Propane or Natural Gas. Identification labels are found on the shipping box, and on the rating plate sticker which is located on the right side panel of the cover.

MODEL / N° DE SÉRIE		N° DE SÉRIE / MODEL	
SERIAL / N° DE CHANGEMENT		N° DE CHANGEMENT / SERIAL	
<p>PLEASE PRINT OR TYPE IN BLOCK LETTERS. DO NOT WRITE IN THESE SPACES.</p> <p>PLEASE PRINT OR TYPE IN BLOCK LETTERS. NE PAS ÉCRIRE DANS CES ESPACES.</p>			
<p>PLEASE PRINT OR TYPE IN BLOCK LETTERS. DO NOT WRITE IN THESE SPACES.</p> <p>PLEASE PRINT OR TYPE IN BLOCK LETTERS. NE PAS ÉCRIRE DANS CES ESPACES.</p>			
<p>1. SERIAL NUMBER</p> <p>2. TYPE OF GAS</p>		<p>3. GAS PRESSURE</p> <p>4. GAS SUPPLY PRESS.</p>	
<p>5. GAS SUPPLY PRESS.</p> <p>6. GAS SUPPLY PRESS.</p>		<p>7. GAS SUPPLY PRESS.</p> <p>8. GAS SUPPLY PRESS.</p>	
<p>9. GAS SUPPLY PRESS.</p> <p>10. GAS SUPPLY PRESS.</p>		<p>11. GAS SUPPLY PRESS.</p> <p>12. GAS SUPPLY PRESS.</p>	
<p>13. GAS SUPPLY PRESS.</p> <p>14. GAS SUPPLY PRESS.</p>		<p>15. GAS SUPPLY PRESS.</p> <p>16. GAS SUPPLY PRESS.</p>	
<p>17. GAS SUPPLY PRESS.</p> <p>18. GAS SUPPLY PRESS.</p>		<p>19. GAS SUPPLY PRESS.</p> <p>20. GAS SUPPLY PRESS.</p>	
<p>21. GAS SUPPLY PRESS.</p> <p>22. GAS SUPPLY PRESS.</p>		<p>23. GAS SUPPLY PRESS.</p> <p>24. GAS SUPPLY PRESS.</p>	
<p>25. GAS SUPPLY PRESS.</p> <p>26. GAS SUPPLY PRESS.</p>		<p>27. GAS SUPPLY PRESS.</p> <p>28. GAS SUPPLY PRESS.</p>	
<p>29. GAS SUPPLY PRESS.</p> <p>30. GAS SUPPLY PRESS.</p>		<p>31. GAS SUPPLY PRESS.</p> <p>32. GAS SUPPLY PRESS.</p>	
<p>33. GAS SUPPLY PRESS.</p> <p>34. GAS SUPPLY PRESS.</p>		<p>35. GAS SUPPLY PRESS.</p> <p>36. GAS SUPPLY PRESS.</p>	
<p>37. GAS SUPPLY PRESS.</p> <p>38. GAS SUPPLY PRESS.</p>		<p>39. GAS SUPPLY PRESS.</p> <p>40. GAS SUPPLY PRESS.</p>	
<p>41. GAS SUPPLY PRESS.</p> <p>42. GAS SUPPLY PRESS.</p>		<p>43. GAS SUPPLY PRESS.</p> <p>44. GAS SUPPLY PRESS.</p>	
<p>45. GAS SUPPLY PRESS.</p> <p>46. GAS SUPPLY PRESS.</p>		<p>47. GAS SUPPLY PRESS.</p> <p>48. GAS SUPPLY PRESS.</p>	
<p>49. GAS SUPPLY PRESS.</p> <p>50. GAS SUPPLY PRESS.</p>		<p>51. GAS SUPPLY PRESS.</p> <p>52. GAS SUPPLY PRESS.</p>	
<p>53. GAS SUPPLY PRESS.</p> <p>54. GAS SUPPLY PRESS.</p>		<p>55. GAS SUPPLY PRESS.</p> <p>56. GAS SUPPLY PRESS.</p>	
<p>57. GAS SUPPLY PRESS.</p> <p>58. GAS SUPPLY PRESS.</p>		<p>59. GAS SUPPLY PRESS.</p> <p>60. GAS SUPPLY PRESS.</p>	
<p>61. GAS SUPPLY PRESS.</p> <p>62. GAS SUPPLY PRESS.</p>		<p>63. GAS SUPPLY PRESS.</p> <p>64. GAS SUPPLY PRESS.</p>	
<p>65. GAS SUPPLY PRESS.</p> <p>66. GAS SUPPLY PRESS.</p>		<p>67. GAS SUPPLY PRESS.</p> <p>68. GAS SUPPLY PRESS.</p>	
<p>69. GAS SUPPLY PRESS.</p> <p>70. GAS SUPPLY PRESS.</p>		<p>71. GAS SUPPLY PRESS.</p> <p>72. GAS SUPPLY PRESS.</p>	
<p>73. GAS SUPPLY PRESS.</p> <p>74. GAS SUPPLY PRESS.</p>		<p>75. GAS SUPPLY PRESS.</p> <p>76. GAS SUPPLY PRESS.</p>	
<p>77. GAS SUPPLY PRESS.</p> <p>78. GAS SUPPLY PRESS.</p>		<p>79. GAS SUPPLY PRESS.</p> <p>80. GAS SUPPLY PRESS.</p>	
<p>81. GAS SUPPLY PRESS.</p> <p>82. GAS SUPPLY PRESS.</p>		<p>83. GAS SUPPLY PRESS.</p> <p>84. GAS SUPPLY PRESS.</p>	
<p>85. GAS SUPPLY PRESS.</p> <p>86. GAS SUPPLY PRESS.</p>		<p>87. GAS SUPPLY PRESS.</p> <p>88. GAS SUPPLY PRESS.</p>	
<p>89. GAS SUPPLY PRESS.</p> <p>90. GAS SUPPLY PRESS.</p>		<p>91. GAS SUPPLY PRESS.</p> <p>92. GAS SUPPLY PRESS.</p>	
<p>93. GAS SUPPLY PRESS.</p> <p>94. GAS SUPPLY PRESS.</p>		<p>95. GAS SUPPLY PRESS.</p> <p>96. GAS SUPPLY PRESS.</p>	
<p>97. GAS SUPPLY PRESS.</p> <p>98. GAS SUPPLY PRESS.</p>		<p>99. GAS SUPPLY PRESS.</p> <p>100. GAS SUPPLY PRESS.</p>	

Fig. 2 Rating plate sticker

- A Serial number
- B Type of gas

The box includes:

- Pressure relief valve (150 psi / 200,000 Btu rating)
- Bracket for wall hanging the heater

- Exhaust vent adaptor (with 4 screws and gasket provided)
- Condensate drain tube kit
- Combustion air inlet adaptor (with 3 screws and gasket provided)
- Plastic decal shields for covering front cover screws and control panel, installer should affix these decals to the front of the unit after installation is complete. See Fig. 3
- Installation manual (replacement manuals can be downloaded at www.boschpro.com)
- Product registration card
- Energy Guide label.

Please complete and return the enclosed product registration card.

The GWH-635-ES is not approved or designed for:

- Manufactured (mobile) homes, RV's, boats or any mobile installation.
- Heating or other recirculating/pumping applications*
- Solar/preheat backup or high temperature booster use.

* This includes domestic hot water circulator pump loop systems that may be installed in home hot water system prior to installing this unit. An approved recirculation design can be found in chapter 3.9. The use of a small electric mini-tank water heater (4-6 gallon size) must be used for this application and designed so the pump will circulate the hot water in the mini-tank only and through the building's hot water return loop (timed or thermostatic controlled operation of the pump is commonly done). The GWH-635-ES must be plumbed in line before the mini-tank water heater and supplied with cold water only. Contact Bosch Water Heating if further instruction is needed.

To remove front cover

- Loosen the two Philips head screws located on front panel (beneath plastic decal shields if they are already attached, see Fig. 3)
- Lift front cover panel upward and remove.

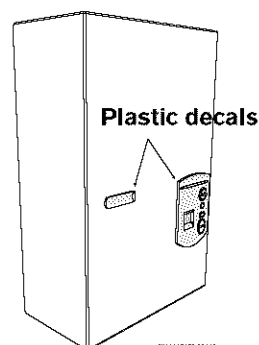

Fig. 3 Remove front cover

2.4 General rules to follow for safe operation

- ▶ **1.** You must follow these instructions when you install your heater. In the United States: The installation must conform with local codes or, in the absence of local codes, the National Fuel Gas Code ANSI Z223.1/NFPA 54.
In Canada: The Installation must conform with CGA B149.(1,2) INSTALLATION CODES and /or local installation codes.
- ▶ **2.** Carefully plan where you install the heater. Correct combustion air supply and vent pipe installation are very important. If not installed correctly, fatal accidents can be caused by lack of air, carbon monoxide poisoning or fire.
- ▶ **3.** When the unit is installed indoors with ROOM SEALED (twin pipe) combustion air and venting, it is permitted to be located in bathrooms, bedrooms and occupied rooms that are normally kept closed. See chapter 3.6. If the unit will be installed indoors and use indoor combustion air, the place where you install the heater must have enough ventilation. **The National Fuel Gas Code and National Fire Codes do not allow UNSEALED gas fired water heater installations in bathrooms, bedrooms or any occupied rooms normally kept closed.** See chapter 3.2 and 3.5.
- ▶ **4.** You must vent your heater. See section on VENTING.
- ▶ **5.** The appliance and its gas connection must be leak tested before placing the appliance in operation. The appliance must be isolated from the gas supply piping system by closing its individual manual gas shutoff valve (not supplied with heater) during any pressure testing at pressures in excess of 1/2 Psig (3.5 kPa).
- ▶ **6.** Keep water heater area clear and free from combustibles and flammable liquids. Do not locate the heater over any material which might burn.
- ▶ **7. Correct gas pressure** is critical for the optimum operation of this heater. Gas piping must be sized to provide the required pressure at the maximum output of the heater, while all the other gas appliances are in operation. Check with your local gas supplier and see Chapter 3.7 Gas piping and connections.
- ▶ **8.** Should overheating occur or the gas supply fail to shut off, turn off the gas supply at the manual gas shut off valve, on the gas line. Note: manual gas shutoff valve is not supplied with the heater.
- ▶ **9.** Do not use this appliance if any part has been underwater. Immediately call a qualified service technician to inspect the appliance and to replace any part of the control system and any gas control which has been underwater.
- ▶ **10.** Failure to install heater correctly may lead to unsafe operation and void the warranty.
- ▶ **11.** The heater must not be installed in an unheated area where temperatures will reach 36°F or lower. If the heater is left in an area susceptible to such temperatures, refer to Section 5.4 on Winterizing.
- ▶ **12.** In areas where water supply has a high mineral content, a water softener is strongly recommended. Damage to the water heater resulting from hard water/scale deposits will not be covered under warranty.
- ▶ **13.** In areas with warm inlet water (70°F or greater), increasing flow rate at low flowing fixtures may be required to prevent outlet temperatures from exceeding the desired temperature set point.

2.5 Dimensions and Minimum installation clearances

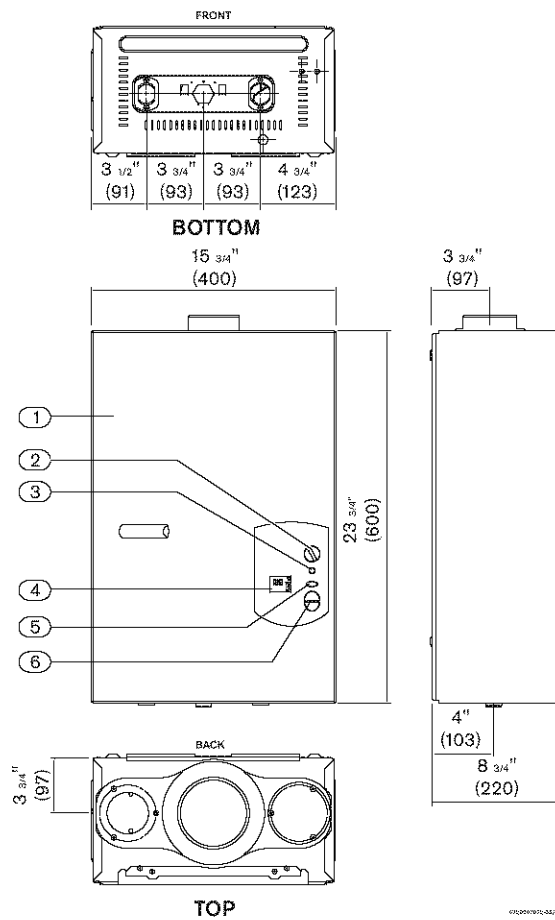

Fig. 4 Dimensions

- 1 Cover
- 2 On/Off switch
- 3 Reset button
- 4 LCD display
- 5 Program button
- 6 Temperature buttons

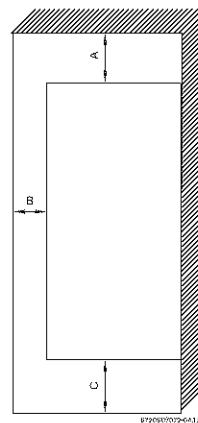

Fig. 5 Minimum clearances

	Model GWH-635-ES
TOP (A)	12"
FRONT (B)	1"
BACK	0"
SIDES	1"
FLOOR (C)	12"

Table 1 Minimum clearances

3 Installation instructions

3.1 Introduction

Please follow these instructions. Failure to follow instructions may result in:

- ▶ Damage or injury.
- ▶ Improper operation.
- ▶ Loss of warranty.

If you are unable to perform the tasks required to install this heater properly, please contact a locally licensed plumber or gas technician.

Please contact Bosch Water Heating with any questions.

3.2 Proper location for installing your heater

Carefully select the location of the water heater. For your safety and for proper heater operation, you must provide combustion air to the heater and a proper exhaust vent system.

Follow the guidelines below:

- ▶ **1.** Locate the heater where venting, gas and plumbing connections are feasible and convenient.
- ▶ **2.** The hot water lines should be kept short to save energy. Centrally locating the water heater is recommended to keep hot water distribution times even throughout the structure. It is always best to have hot water lines insulated.



Warning: The water in this water heater is cold and always remains cold except for the times the burners are on. In the event of power outage during freezing temperatures, it is recommended that the heater be drained.

See chapter 5.5 "Winterizing" for draining instructions.



Warning: Flammable materials, gasoline, pressurized containers, or any other items or articles that are potential fire hazards must NOT be placed on or adjacent to the heater. The appliance area must be kept free of all combustible materials, gasoline and other flammable vapors and liquids.



Warning: The water heater must be installed in a conditioned space where temperatures will not fall below 36F.

3.3 Heater placement and clearances

The GWH-635-ES is design certified for installation on a combustible wall (see 3.4 Mounting installation) provided the floor covering below the heater is noncombustible. For installations in an alcove or closet, maintain the minimum clearances to combustible and non-combustible materials listed below. See also Fig. 5.

- A. Top 12 inches (306 mm)
- B. Front 1 inches (25 mm)
- C. Back 0 inches
- D. Sides 1 inches (25 mm)
- E. Bottom 12 inches (306 mm)

Clearances from any exhaust vent pipe are dependent upon the clearance requirements of the stainless steel vent pipe manufacturer. Single wall stainless steel (AL29-4C) vent pipe (vent type rated for Category III appliances) must be used when exhaust venting this appliance. See 3.6 Venting.

3.4 Mounting installation



Warning: before starting installation:

- ▶ check that there are no loose parts inside the appliance
- ▶ check the gas type of the heater matches the gas supply you will be connecting the heater
- ▶ ensure that gas pipe, gas valve, mixer, fan and burner have no damage and are properly fitted.



Front cover should be removed (see instructions on page 5) in order to inspect components visually.

- ▶ Secure the wall mounting bracket provided with the heater to a wall surface.



Warning: Do not install this appliance on a carpeted wall. The heater must be mounted on a wall using appropriate anchoring materials.

If wall is sheathed with plasterboard, it is recommended that two support boards, either 1"x4" or 1/2" (minimum) plywood first be attached across a pair of studs. Then attach the heater's bracket to the upper support board. The heater should be kept level on the wall surface. See Fig. 6.

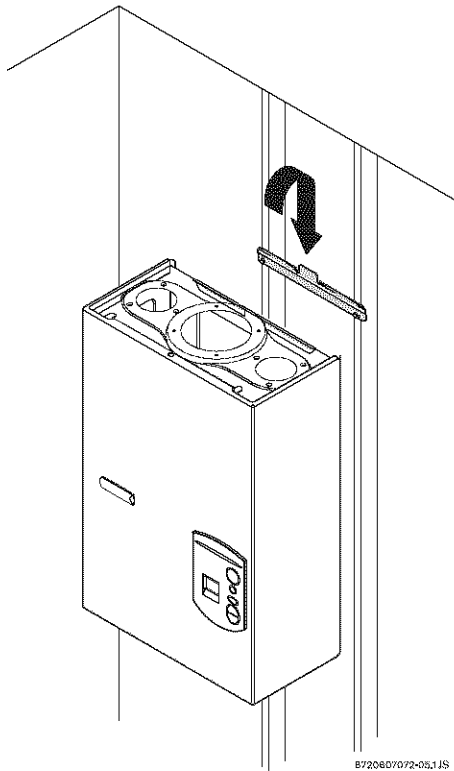

Fig. 6 Mounting the heater

3.5 Combustion air requirements

Warning: In areas where outside temperatures commonly fall below 36°F, a twin pipe venting system is required. Failure to do so may result in cold outside air being drawn across the heat exchanger causing it to freeze and burst. This failure is not covered under the manufacturer's warranty.

Warning: When installed in an environment where corrosive chemicals or dirty air are present, the twin pipe system is required.

Twin pipe method:

The GWH-635-ES is designed as a sealed combustion appliance. It is recommended that the combustion air be provided by a dedicated 3" or 4" pipe to the outside. The combustion air pipe may be aluminum flex, PVC or any other rigid or semi rigid sealed 3" or 4" pipe. The combustion air inlet, whether terminating vertically or horizontally, must be located in such a manner as to provide a minimum 3 foot clearance from the exhaust vent terminator. See Fig. 17 Letter I.

The maximum length of the combustion air inlet is 26 feet with one elbow. Subtract 2.5 feet for additional elbows. Maximum number of elbows permitted is 3. Horizontally terminating combustion air pipes must

pitch down towards termination 1/4 inch for every foot of horizontal length.

Single pipe method:

Although it is permissible to draw combustion air from the inside, it is not the manufacturer's recommended installation method. Always install a 3 inch elbow on the top of the combustion air inlet adaptor to prevent foreign objects from falling into the unit.

If a single pipe installation is utilized, follow guidelines below for providing adequate combustion air for the water heater as well as any other appliances that may consume air in the space. Always follow local codes if they are more stringent.

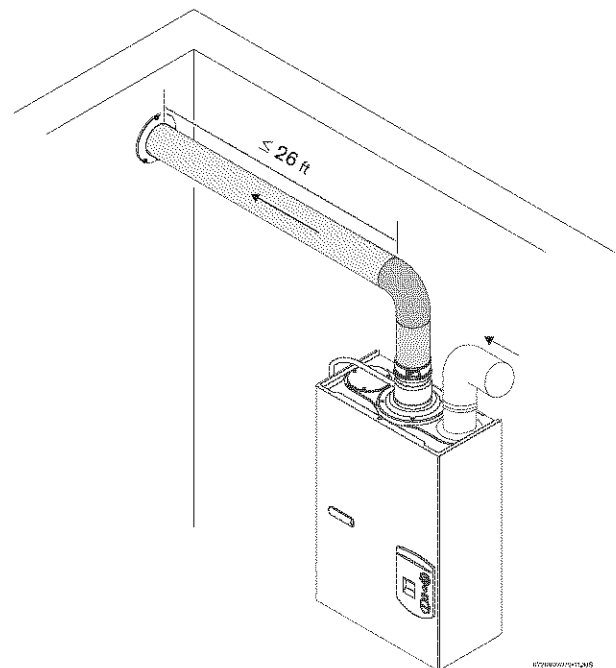

Fig. 7 Single pipe installation

The GWH-635-ES water heater holds cold water in its copper heat exchanger and water valve when not in use. Because of this, any cold air that comes through the unit's vent pipe could freeze and damage these components. This Installation Manual specifies the minimum vertical vent pipe and the amount of combustion air required for this unit. When all requirements are followed, the unit will operate properly and safely. However, there may still be a risk of freezing due to negative draft if the other combustion appliances in the building are not supplied with sufficient combustion air. A wood stove or furnace can pull its combustion air from the heater's vent pipe, allowing the cold incoming air to freeze the cold water in the heat exchanger. Supplying more combustion air for all combustion appliances is the solution. A HVAC specialist should be consulted to design solutions for providing more combustion air. Observe the following guidelines:

Installations in structures that have been tightly constructed (air infiltration rate of 0.40 ACH or less) must be provided with combustion air per the National

Installation instructions

Fuel Gas Code. Consult a HVAC specialist if your air infiltration rate is questionable.

The space must have two permanent openings, one commencing within 12 inches of the top and one commencing within 12 inches of the bottom of the enclosure. Each opening must have a minimum free area of one square inch per:

- 1000 Btu/hr if all air is taken from inside the building
- 2000 Btu/hr if all air is taken from the outside by horizontal ducts
- 4000 Btu/hr if all air is taken from the outside by direct openings or vertical ducts.

Or the space must be provided with one permanent opening or duct that is within 12 inches of the ceiling of the enclosure. This opening must have a minimum free area of one square inch per:

- 3000 Btu/hr if all air is taken from the outside by a direct opening or vertical duct.

Louvers, grills and screens have a blocking effect. If the effective free area is not known, increase the sizes of your openings by 300% if your louvers are wood and by 35% if your louvers are metal. Refer to the National Fuel Gas Code for complete information.

3.6 Venting

 **Danger:** Do not combination vent this appliance with any other appliance.

 **Warning:** Do not reduce the vent (exhaust and combustion) pipe sizes and do not common vent with any other vented appliance or stove.

 **Warning:** Failure to vent the exhaust gases to the outside with sealed stainless steel vent pipe (AL29-4C) may result in dangerous flue gases filling the space in which it is installed.

 **Warning:** Single wall exhaust pipe **MUST** be chased through double wall Type-B vent when passing through an unconditioned space.

 **Warning:** The vent system must be installed by a qualified individual in accordance with these instructions. If improperly installed a hazardous condition such as explosion or carbon monoxide poisoning could result. Bosch Water Heating will not be responsible for improperly installed appliances.

3.6.1 Vent material and specifications

Establish vent clearances that comply with the vent manufacturer's specifications. In all cases follow local codes.

Note: Listed thimbles or collars are necessary to pass through wall and ceiling partitions. If the vent system passes through combustible areas where the vent clearance requirements cannot be maintained, it is permissible to chase straight sections of sealed 3 inch single wall vent through 4 inch (or greater) Type-B vent. The distance to combustibles using this chase technique is 1 inch (check local codes).

 **Warning:** Type-B vent must never be used as the actual exhaust vent system for the appliance, because it is not gas tight. This will create a serious health hazard and void the warranty.

Vent lengths

The appliance should be located as close to the point of termination as possible. The maximum vent length is 26 feet (8 m) with one 90 degree elbow. Subtract 2 1/2 feet from the total vent length for each additional 90° elbow used (**a maximum of three 90° elbows are**

permitted in the total vent length), or subtract 1 1/4 feet for every 45° elbow used. Horizontal sections of vent must pitch upwards from heater 1/4" for every foot of horizontal length, to prevent the pooling of condensate, and be supported at 4 foot intervals with overhead hangers. See Table 2.

	Diameter	Minimum length	Maximum length	Material
Exhaust Vent	3 or 4 inches	3 feet	26 feet with 1 90° elbow	Sealed single wall stainless steel (AL29-4C)
Intake Vent	3 or 4 inches	1 90° elbow	26 feet with 1 90° elbow	Sealed aluminum flex, PVC or any other rigid or semi rigid pipe

Table 2 Venting specifications

Minimum exhaust vent size and length

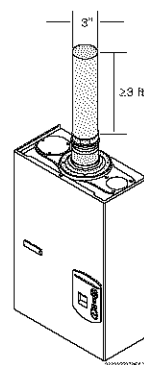

The minimum exhaust vent length is 3 feet.
The use of a 90 degree elbow is equivalent to 2 1/2 ft in vent length.
The use of 45 degree elbow is equivalent to 1 1/4 ft in vent length.

Fig. 8 Minimum exhaust vent length

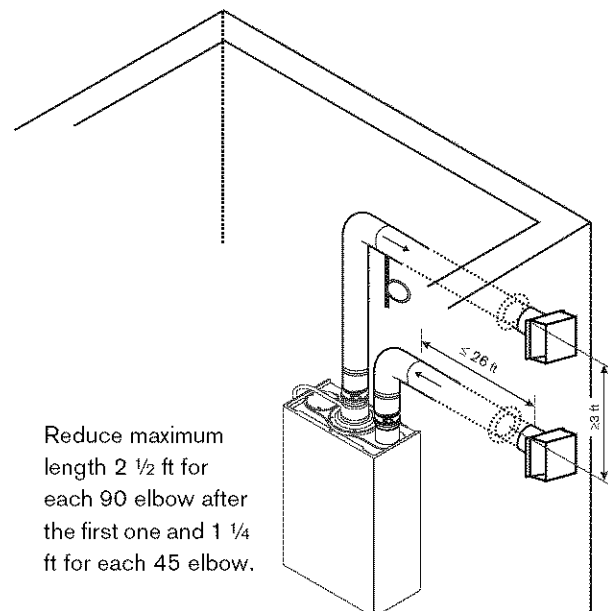

Reduce maximum length 2 1/2 ft for each 90 elbow after the first one and 1 1/4 ft for each 45 elbow.

Fig. 9 Maximum vent and combustion air lengths

Vent material

The GWH-635-ES requires 3 or 4 inch sealed single wall stainless steel vent pipe (AL29-4C). Use of any other vent material will void the manufactures warranty

Installation instructions

and may result in a hazardous condition. For specific questions concerning vent material, specifications, usage or installation, contact the vent manufacturer directly.

Vent manufacturer	Contact information
Z-flex	www.z-flex.com 800-654-5600
ProTech Industries	www.protechinfo.com 800-766-3473
Heat-Fab	www.heatfab.com 800-772-0739

Table 3 Vent manufacturer contact information

	Z flex	ProTech	Heat Fab
3" Venting			
3" Horizontal termination	2SVSTB03	FSTB3	9390 TEE
3" Vertical termination	2SVSRCF03	FSRC3	5300CI
90° Condensate Drain Tee	2SVEVWCF03	FST3 & FSDF3	93PPLSTEE
Horizontal Condensate Drain	2SVEDWCF03	FSHDT3	9321
Vertical Condensate Drain	2SVSEVDP03	N/A	N/A
Condensate Drain Tube	2SVEDTK	N/A	7000TUBE
4" Venting			
3" to 4" Increaser (Required)	2SVI0304	FS0304TI	9374
4" Horizontal termination	2SVSRTF04	FSTB4	9490TEE
4" Vertical termination	2SVSRCF04	FSRC4	5400CI
90° Condensate Drain Tee	2SVEVWCF04	FST4 & FSDF4	9416 & 9417D
Horizontal Condensate Drain	2SVEDWCF04	FSHDT4	9421
Vertical Condensate Drain	2SVEVDP04	FSUCD4	N/A
Condensate Drain Tube	2SVEDTK	N/A	7000TUBE

Table 4 Approved vent termination and condensate drain part numbers (subject to change)

Vent Safety System

The GWH-635-ES will shut down if inadequate exhaust venting is detected or a lack of combustion air is provided to the unit. See troubleshooting section on

page 33. Correct the problem and then reset the heater before operating.

3.6.2 Vent connections

Exhaust vent connection

- ▶ Attach the flue gas exhaust accessory (8 705 504 137) to the top of the unit (position 1) using the 4 screws and gasket provided.
- ▶ Insert single wall stainless steel vent pipe into the exhaust vent adapter 1.5" and tighten the clamp (Fig. 10 position 2).

Note: 3 to 4 inch increaser required when using 4 inch pipe.

Note: Failure to fully insert vent pipe and tighten clamp may cause flue gas leakage or condensate damage that is not covered under the manufacturer's warranty.

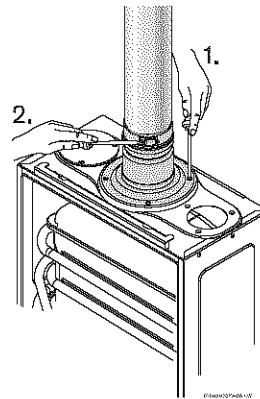

Fig. 10 Exhaust vent connection

Combustion air inlet connection

The combustion air inlet accessory can be connected either to the top right or left of the appliance. The unused side must be sealed.

- ▶ Attach the combustion air inlet accessory (8 705 504 115) to the top of the unit (position 3) using the 3 screws and gasket provided.
- ▶ Install combustion air pipe over the air inlet accessory. If using flexible piping, secure with a clamp (position 4, not included).

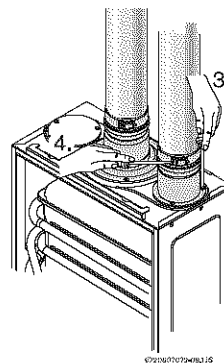

Fig. 11 Combustion air inlet connection

3.6.3 Condensate drain tube requirements

Exhaust collar condensate drain installation (supplied with heater)

- ▶ The condensate drain tube kit must be used for all installation types. **Failure to properly install condensate drain will void the warranty.**
- ▶ When installing the condensate drain tube kit on the exhaust collar (see diagram below), be sure to form a trap by means of a 3" (76.2 mm) loop partially filled with water. This loop must be as low as possible to allow proper drainage of condensate. The supplied tube is 3/8" ID high temperature silicone and must be attached to the condensate port on the exhaust collar with its supplied gear clamp (first remove brass screw from port).
- ▶ To increase tube length, connect vinyl tubing (not supplied with heater) to the supplied tube. Do not reduce tubing diameter when using connector or additional tubing.
- ▶ The condensate must be disposed of according to local regulations.

Condensate port on exhaust collar

1. Remove brass hex head screw

2. Fit tube with gear clamp

3. Loop size and location. Coil tube into 3" loop with nylon tie (don't crimp tubing) and fill **bottom** of loop with water

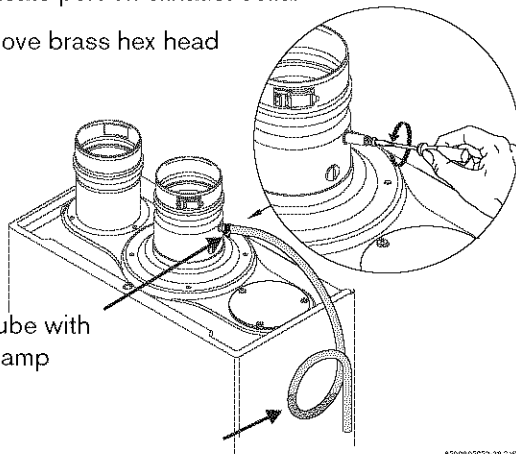

Fig. 12 Exhaust collar condensate drain installation

Note: No part of supplied silicone tube should be installed above condensate tapping or improper drainage may occur. (see Fig. 12).

External condensate drain installation (not supplied)

An additional external condensate drain must be installed under the following conditions:

- Vertical terminating vent installations
- Horizontal terminating vent installations where the total vent length is greater than 5 feet
- Vent installation where any section of the exhaust vent pipe passes through an unconditioned space.

Note: Condensate must be disposed of according to local codes.

Note: Do not install condensate drain in areas where it may freeze.

1. Install condensate drain as close to heater as possible.
2. Use 3/8" ID high temperature silicone tubing to connect to condensate drain port. Do not use copper piping for any portion of the condensate drain.
3. Form a condensate trap by means of a 3" loop and fill bottom of loop with water.
4. To increase the tube length, connect to end of the high temperature silicone tubing with vinyl tubing, PVC or CPVC pipe. Do not reduce the internal diameter at any point.
5. Dispose of condensate according to local codes.

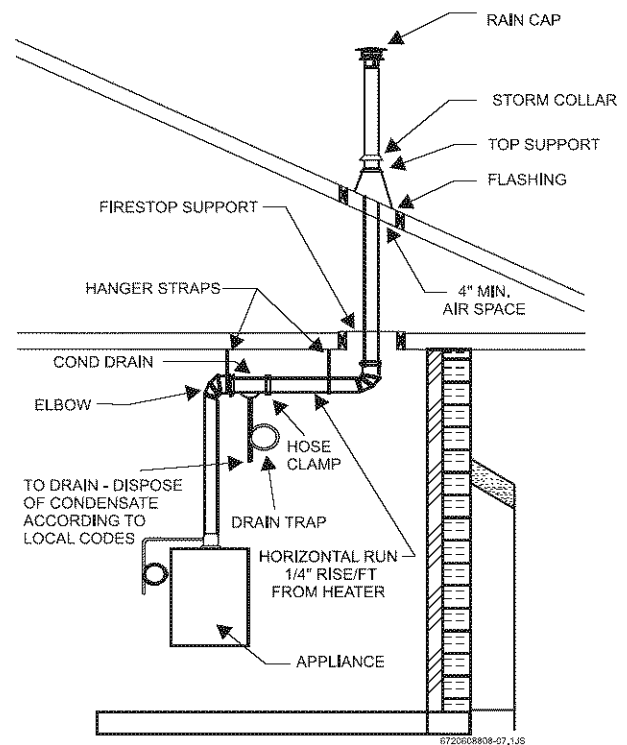

Fig. 13 Required condensate drain installation (Combustion air piping not shown)

3.6.4 Room sealed installation (Twin pipe)



Warning: In areas where outdoor temperatures commonly fall below 36°F, a twin pipe venting system is required. Failure to do so may result in cold outside air being drawn across the heat exchanger causing it to freeze and burst. This failure is not covered under the manufacturer's warranty.

- ▶ Although it is permitted to draw combustion air from inside the structure in warm climates, the recommended method is to provide combustion air through

a 3" or 4" pipe from the outside. See Chapter 3.5 for more direction on combustion air.

- ▶ To reduce pressure differentials between the exhaust and combustion air intake, it is recommended that both terminators exit on the same plane. See Fig. 14 for an example horizontal twin pipe termination and Fig. 15 for the vertical twin pipe termination example.

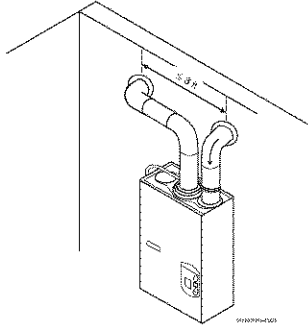

Fig. 14 Horizontal twin pipe termination

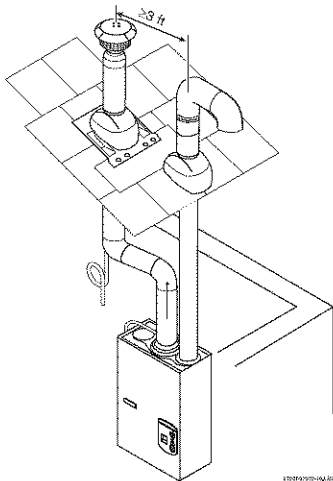

Fig. 15 Vertical twin pipe termination

3.6.5 Vertical terminations

Warning: Failure to install a condensate drain may result in damage not covered by the manufacturer's warranty. See chapter 3.6.3. An approved vent terminator must be used. See Table 5 for known approved vertical vent terminations.

Horizontal runs

Any gas vent section that is greater than 45 degrees from the vertical is considered horizontal. Horizontal sections must slope upwards from heater at least 1/4 inch for every foot of its horizontal length and be properly supported to allow condensate to be collected by condensate drains.

Vent terminations

- ▶ No pipe joints other than the termination connections should be exposed to the outdoors. See vent manufacturer instructions for details.
- ▶ Use of two 90° elbows (candy-cane) is an acceptable termination for combustion air intake from the roof. See Fig. 15 for an example.
- ▶ Screening (no smaller than 1/4" mesh) is recommended on candy cane termination.
- ▶ Exhaust should terminate above and must be a minimum of 3 feet from must intake termination.
- ▶ The exhaust vent must terminate above the roof surface with an approved vent cap not less than 3 feet (0.6 m) above the highest point where it passes through the roof and at least 2 feet (0.6 m) higher than any vertical wall or similar obstruction within 10 feet (3.1 m). See Fig. 16 and Table 5.

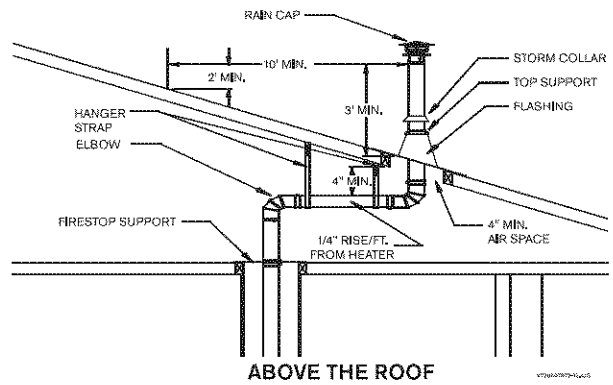

Fig. 16 Vertical vent terminations clearances (Combustion air piping not shown)

GAS VENT TERMINATIONS FOR LISTED VENT CAPS		
Roof pitch	H (min.) feet	meters
Flat to 6/12	1.0	0.30
6/12 to 7/12	1.25	0.38
Over 7/12 to 8/12	1.5	0.46
Over 8/12 to 9/12	2.0	0.61
Over 9/12 to 10/12	2.5	0.76
Over 10/12 to 11/12	3.25	0.99
Over 11/12 to 12/12	4.0	1.22
Over 12/12 to 14/12	5.0	1.52
Over 14/12 to 16/12	6.0	1.83
Over 16/12 to 18/12	7.0	2.13
Over 18/12 to 20/12	7.5	2.27

Table 5 Termination heights at various roof pitches

Over 20/12 to 21/12	8.0	2.44
---------------------	-----	------

Table 5 Termination heights at various roof pitches

Interior masonry chimneys

The single wall stainless steel exhaust vent pipe must be permanently mounted inside the masonry chimney. The masonry chimney may have to be tile or metal lined before the insertion of the gas vent pipe; check local codes for clarification. You may not vent any other fuel burning appliances into any free space remaining in the chimney. The vent terminator must extend at least 3 feet (0.9 m) above where the chimney meets the roofline and at least 2 feet (0.6 m) higher than any vertical wall or similar obstruction within 10 feet (3.1 m). The top of the chimney must be sealed to prevent rain water or other elements from entering the chimney.

Exterior masonry chimneys

Refer to the National Fuel Gas Code and consult a local venting HVAC contractor. Not recommended in cold climates.

3.6.6 Horizontal terminations

- For horizontal vent runs less than 5 linear feet, the entire vent run must pitch down to termination 1/4" per foot to eliminate the danger of rain from entering the venting system.
- The exhaust vent must terminate immediately once it penetrates the outside wall.
- An approved vent terminator must be used. See Table 4 for known approved horizontal vent terminations.
- Install an additional condensate drain (not supplied) if the total straight vent length is greater than 5 feet or if the exhaust vent pipe passes through an unconditioned space.
- Terminating the intake air piping above the exhaust termination is not recommended.
- Fig. 17 and table 6 show the required clearances for the vent termination. Follow local codes if more stringent.

3.6.6.1 Attention residents of the Commonwealth of Massachusetts:

In the Commonwealth of Massachusetts the following regulation went into effect on 12/30/2005:

(a) For all side wall horizontally vented gas fueled equipment installed in every dwelling, building or structure used in whole or in part for residential purposes, including those owned or operated by the Commonwealth and where the side wall exhaust vent termination is less than seven (7) feet above finished grade in the area of the venting, including but not limited to decks and porches, the following requirements shall be satisfied:

1. INSTALLATION OF CARBON MONOXIDE DETECTORS. At the time of installation of the side wall hor-

izontal vented gas fueled equipment, the installing plumber or gasfitter shall observe that a hard wired carbon monoxide detector with an alarm and battery back-up is installed on the floor level where the gas equipment is to be installed. In addition, the installing plumber or gasfitter shall observe that a battery operated or hard wired carbon monoxide detector with an alarm is installed on each additional level of the dwelling, building or structure served by the side wall horizontal vented gas fueled equipment. It shall be the responsibility of the property owner to secure the services of qualified licensed professionals for the installation of hard wired carbon monoxide detectors.

a. In the event that the side wall horizontally vented gas fueled equipment is installed in a crawl space or an attic, the hard wired carbon monoxide detector with alarm and battery back-up may be installed on the next adjacent floor level.

b. In the event that the requirements of this subdivision can not be met at the time of completion of installation, the owner shall have a period of thirty (30) days to comply with the above requirements; provided, however, that during said thirty (30) day period, a battery operated carbon monoxide detector with an alarm shall be installed.

2. APPROVED CARBON MONOXIDE DETECTORS.

Each carbon monoxide detector as required in accordance with the above provisions shall comply with NFPA 720 and be ANSI/UL 2034 listed and IAS certified.

3. SIGNAGE. A metal or plastic identification plate shall be permanently mounted to the exterior of the building at a minimum height of eight (8) feet above grade directly in line with the exhaust vent terminal for the horizontally vented gas fueled heating appliance or equipment. The sign shall read, in print size no less than one half (1/2) inch in size, "**GAS VENT DIRECTLY BELOW. KEEP CLEAR OF ALL OBSTRUCTIONS**".

4. INSPECTION. The state or local gas inspector of the side wall horizontally vented gas fueled equipment shall not approve the installation unless, upon inspection, the inspector observes carbon monoxide detectors and signage installed in accordance with the provisions of 248 CMR 5.08(2)(a)1 through 4.

(b) **EXEMPTIONS:** The following equipment is exempt from 248 CMR 5.08(2)(a)1 through 4:

1. The equipment listed in Chapter 10 entitled "Equipment Not Required To Be Vented" in the most current edition of NFPA 54 as adopted by the Board; and

2. Product approved side wall horizontally vented gas fueled equipment installed in a room or structure separate from the dwelling, building or structure used in whole or in part for residential purposes.

(c) MANUFACTURERS REQUIREMENTS - GAS

EQUIPMENT VENTING SYSTEM REQUIRED.

When the manufacturer of Product Approved side wall horizontally mounted gas equipment provides a venting system design or venting system components with the equipment, the instructions provided by the manufacturer for the installation of the equipment and the venting shall include:

1. Detailed instructions for the installation of the venting system or the venting system components; and
2. A complete parts list for the venting system design or venting system.

(d) MANUFACTURER REQUIREMENTS - GAS EQUIPMENT VENTING SYSTEM NOT PROVIDED.

When the manufacturer of a product approved side wall horizontally vented gas fueled equipment does not provide the parts for the venting of flue gases, but identifies "special venting systems," the following requirements shall be satisfied by the manufacturer:

1. The referenced "special venting system" instructions shall be included with the appliance or equipment installation instructions; and
2. The "special venting systems" shall be product approved by the Board, and the instructions for that system shall include a parts list and detailed installation instructions.

(e) A copy of all installation instructions for all products approved side wall horizontally vented gas fueled equipment, all venting instructions, all parts lists for venting instructions, and/or all venting design instructions shall remain with the appliance or equipment at the completion of the installation.

Recommended exhaust vent terminator clearances

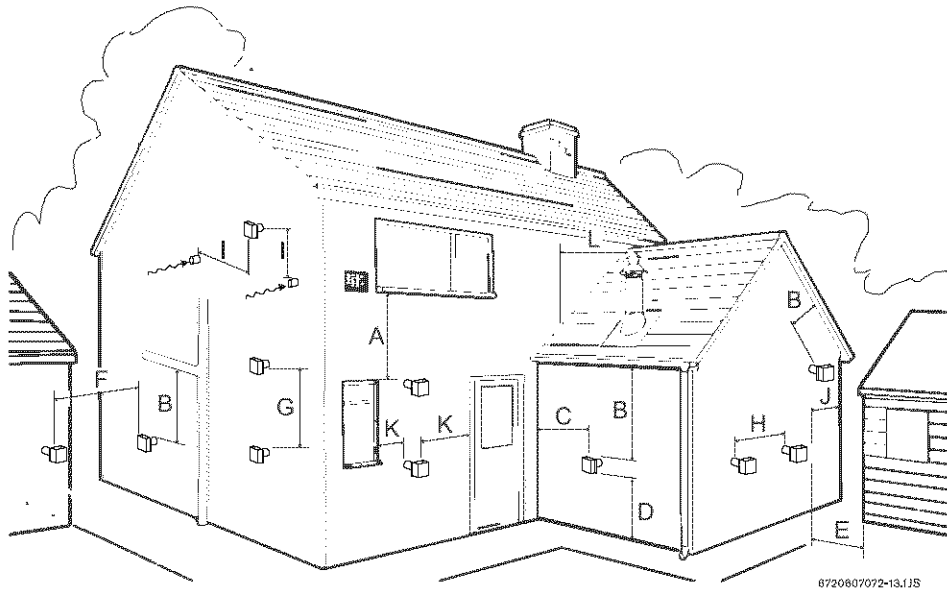

Fig. 17

Ref.	Description	Minimum distance
A	Directly below an opening; operable windows, doors and any non-mechanical fresh air openings	36 in (twin pipe installation) 48 in (single pipe installation)
B	Below a gutter, sanitary pipework or eaves	24 in
	Below a gutter, sanitary pipework or eaves, protected by metal shielding	12 in
C	From any internal corner	12 in
D*	Above ground or snow pack	12 in
	Above a paved sidewalk	7 ft
E	From an opposing wall or structure facing the termination	24 in
	From the relief valve of a gas regulator	36 in
F	From a terminator facing a terminator	48 in
G	Vertically between two exhaust vent terminators on the same wall	60 in
H	Horizontally between two exhaust vent terminators on the same wall	12 in
I**	Horizontally and vertically from combustion air inlet of a twin pipe system	36 in
	From the gravity combustion air inlet any other equipment	48 in
J	From any external corner	12 in
K	Horizontally from an opening; operable windows, doors and any non-mechanical fresh air openings	12 in (twin pipe installation) 48 in (single pipe installation)
L	Vertically from a wall, roof slope, or obstruction (venting through a flat or pitched roof)	see Chapter 3.6.5

Table 6

* Subject to local codes and anticipated snow level

** Other equipment that operates with a mechanical air inlet may require greater distances, reference manufacturer's instructions

NOTE: terminating exhaust vent under a deck is not recommended

3.6.7 Exhaust vent configuration examples

Supporting the exhaust vent system

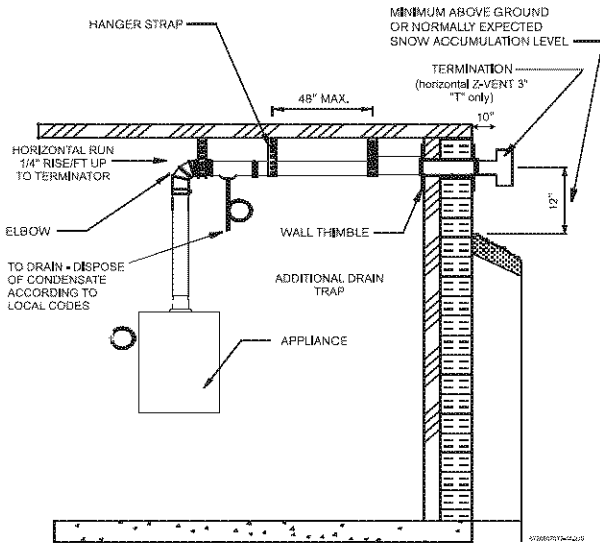

Fig. 18 Horizontal side wall venting installation (combustion air piping not shown)

Note: Pitch venting up 1/4" per foot to termination and add additional condensate drain for vent runs longer than 5 linear feet.

Note: Pitch venting down 1/4" per foot to termination for vent runs less than 5 linear feet.

Note: For horizontal terminations, venting must terminate once it penetrates to the outside of the structure. There should be no sections of vent pipe exposed to the outdoors.

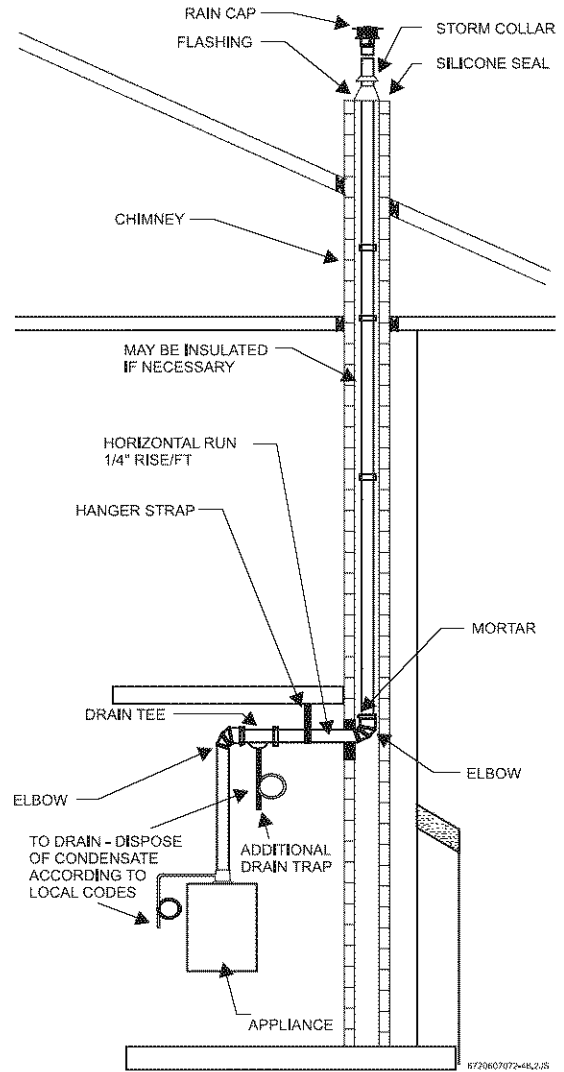

Fig. 20 Vertical venting installation - Interior masonry Chimney (combustion air piping not shown)

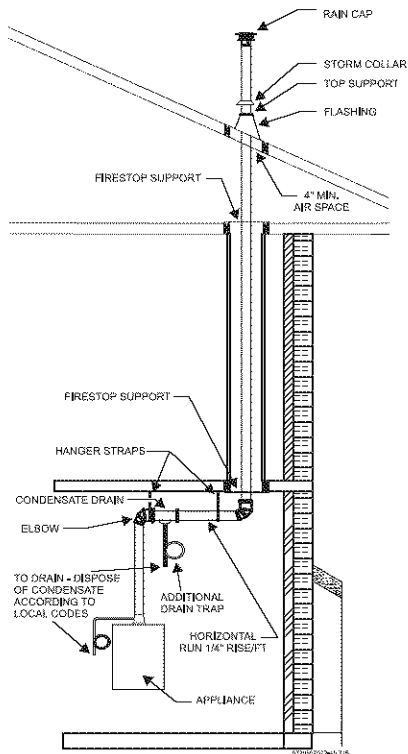

Fig. 19 Vertical venting installation (combustion air piping not shown)

3.7 Gas piping & connections



Before connecting the gas supply, check the rating plate on the right side of the heater to be sure that the heater is rated for the same gas to which it will be connected.

In the United States: The installation must conform with local codes or, in the absence of local codes, the National Fuel Gas Code ANSI Z223.1/NFPA 54.

In Canada: The Installation must conform to CGA B149 INSTALLATION CODES and/or local installation codes.



Warning: DO NOT connect to an unregulated or high pressure propane line or to a high pressure commercial natural gas line.



Warning: The heater must be isolated from the gas supply piping system during any pressure testing of that system at test pressures equal to or more than 0.5 psig. If overpressure has occurred, such as through improper testing of the gas lines or malfunction of the supply system, the gas valve must be checked for safe operation.

GAS CONNECTIONS

- ▶ Install a manual gas shut off valve on the gas supply line.
- ▶ Install a union when connecting gas supply.
- ▶ The minimum diameter required for any appliance connector used is $\frac{3}{4}$ " ID.
- ▶ National Fuel Gas Code requires that a sediment trap (drip leg) be installed on gas appliances not so equipped. The drip leg must be accessible and not subject to freezing conditions. Install in accordance with the recommendations of the serving gas supplier.

Once connections are made, check for gas leaks at all joints. Apply some gas leak detection solution to all gas fittings. Bubbles are a sign of a leak. A combustible gas detector may also be used to detect for leaks.



Danger: If you have a leak, shut off the gas. Tighten appropriate fittings to stop leak. Turn the gas on and check again with a gas leak detection solution. Never test for gas leaks using a match or flame.

GAS LINE SIZING

The gas supply piping should be sized for a maximum draw of 175,000 BTUH. Measure the length of gas supply line and use the tables in Fig. 22 or the gas line

manufacturer's sizing tables to determine the pipe diameter necessary to accommodate the 175,000 BTU demand of the heater. If there are more gas drawing appliances on the line, size the gas line according to the total maximum amount of BTU draw for all appliances.

Note: Under sizing the gas line may result in diminished output and improper operation. See chapter 3.8 for the procedure to confirm gas pressure. Proper gas pressure must be confirmed at time of installation.

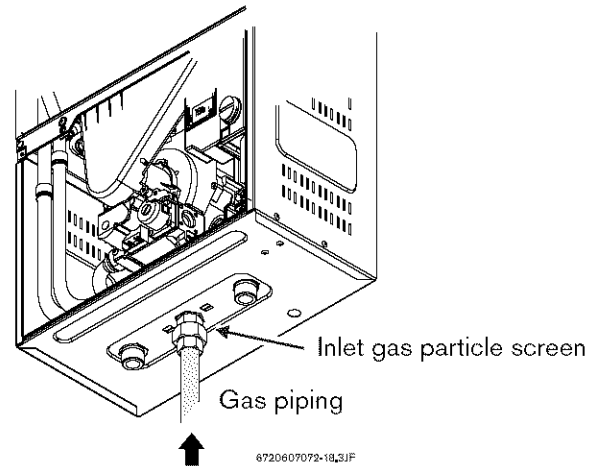

Fig. 21

FOR NATURAL GAS

Maximum Capacity of pipe in Cubic Feet of Gas per Hour for Gas Pressure of 0.5 Psig or less and a Pressure drop of 0.3" in Water Column (0.75mbar).(Based on a 0.60 Specific Gravity Gas) Btu numbers given in thousands.

Follow boxed numbers for piping just one GWH-635-ES (example: 3/4" B.I. Natural Gas pipe for 20 ft (6.1m). will handle 190,000 btu's (55.7 kWh). For multiple appliances combine the total btu input load and then refer to applicable chart below.

Nominal Iron Pipe Size, inches	Internal Diameter inches	Length of Black Iron Pipe, Feet													
		10	20	30	40	50	60	70	80	90	100	125	150	175	200
1/4	0.364	32	22	18	15	14	12	11	11	10	9	8	8	7	6
3/8	0.493	72	49	40	34	30	27	25	23	22	21	18	17	15	14
1/2	0.622	132	92	73	63	56	50	46	43	40	38	34	31	28	26
3/4	0.824	278	190	152	130	115	105	96	90	84	79	72	64	59	55
1	1.049	520	350	285	245	215	195	180	170	160	150	130	120	110	100
1 1/4	1.380	1050	730	590	500	440	400	370	350	320	305	275	250	225	210
1 1/2	1.610	1600	1100	890	760	670	610	560	530	490	460	410	380	350	320
2	2.067	3050	2100	1650	1450	1270	1150	1050	990	930	870	780	710	650	610

Tube size, inches	EHD*	Length of Flexible Corrugated Stainless Steel Tubing (CSST), Feet					
		10	20	30	40	50	60
1/2	18 EHD	82	58	47	41	37	34
3/4	23 EHD	161	116	96	83	75	68
1	30 EHD	330	231	188	162	144	131
1 1/4	37 EHD	639	456	374	325	292	267

* EHD = Equivalent Hydraulic Diameter. The greater the value of EHD, the greater the gas capacity of the tubing.

FOR LP GAS

Maximum Capacity of Pipe in Thousands of BTU per Hour of Undiluted Petroleum Gases (at 11 inches Water Column Inlet Pressure) (Based on a Pressure Drop of 0.5 Inch Water Column).

* EHD = Equivalent Hydraulic Diameter. The greater the value of EHD, the greater the gas capacity of the tubing.

Nominal iron pipe Inches	Black Iron Pipe Length of Pipe, Feet										
	10	20	30	40	50	60	80	100	125	150	200
1/2	291	200	160	137	122	110	94	84	74	67	58
3/4	608	418	336	287	255	231	197	175	155	140	120
1	1145	787	632	541	480	434	372	330	292	265	227

Tube size inches	EHD*	Length of Flexible Corrugated Stainless Steel Tubing (CSST), Feet					
		10	20	30	40	50	60
1/2	18 EHD	129	91	74	64	58	53
3/4	23 EHD	254	183	151	131	118	107
1	30 EHD	521	365	297	256	227	207
1 1/4	37 EHD	971	661	528	449	397	359

Maximum Capacity of Semi-Rigid (flexible, non corrugated) Tubing in Thousands of BTU per Hour of Undiluted Liquefied Petroleum Gases (at 11 inches Water Column Inlet Pressure).

(Based on a Pressure Drop of 0.5 Inch Water Column)

* Source National Fuel Gas Code NFPA 54, ANSI Z223.1 - No Additional Allowance is necessary for an ordinary number of fittings

Outside diameter Inch	Copper Length of Tubing, Feet									
	10	20	30	40	50	60	70	80	90	100
3/8	39	26	21	19	-	-	-	-	-	-
1/2	92	62	50	41	37	35	31	29	27	26
5/8	199	131	107	90	79	72	67	62	59	55
3/4	329	216	181	145	131	121	112	104	95	90

Fig. 22

3.8 Measuring gas pressure

Confirm proper gas pressure upon installation.

Connecting Manometer

- ▶ Shut off gas supply at installer supplied shutoff valve.
- ▶ Remove front cover and locate inlet gas pressure measuring point (see Fig. 24).
- ▶ Loosen screw inside left test point fitting (do not remove) and connect manometer tube to test point. Remove screw completely if correct size adapter is available.

Static Pressure Test

- ▶ Turn gas supply back on.
- ▶ Operate all other gas appliances (except heater) on same gas piping system at maximum output.
- ▶ Record static gas pressure reading in table 7.

Operating Pressure Test

- ▶ ON/OFF switch in position OFF (0).
- ▶ Press and hold "Program" (P) button and turn ON/OFF switch to ON position.

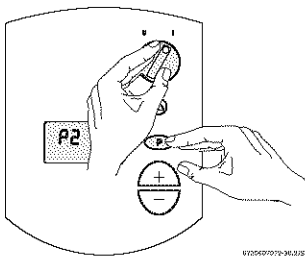

Fig. 23

- ▶ As soon as '188' is displayed, release "Program" (P) button and the display should read P2.
- ▶ Press Δ until P1 appears.

Note: While in this mode the appliance will run constantly at maximum power and allow maximum water flow.

- ▶ Turn on a high volume of hot water (at least 4 gpm) and heater will ignite. If heater display reverts to P2, open more hot water fixtures to allow sufficient flow. Press Δ until P1 reappears on display.
- ▶ Record lowest operating gas pressure reading in table 7.

Gas pressures lower than 5" W.C. for Natural Gas or 11" W.C. for LPG will result in insufficient degree rise to the hot water being used, possible error code faults and must be corrected. See Gas Connections, chapter 3.7.

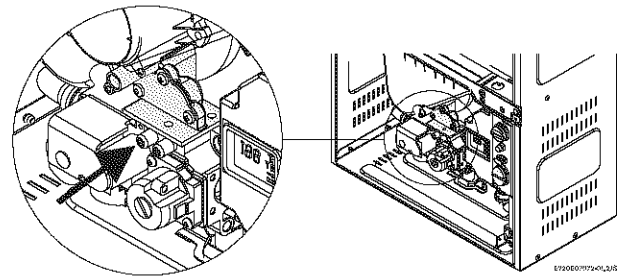

Fig. 24 Gas pressure measuring (left tapping)

<p>Static Gas Pressure Reading (see Chapter 3.8)</p> <p>enter here: _____ Date: _____</p>
<p>Operating Gas Pressure Reading (see Chapter 3.8)</p> <p>enter here: _____ Date: _____</p>

Table 7

HIGH ALTITUDE OPERATION

Altitude	Natural Gas:	Liquid Propane:	
0 - 4,000 ft (0 - 1,219 m)	no modification	no modification	For operation at elevations above 2,000 ft (610 m) the equipment ratings shall be reduced at the rate of 4% for each 1,000 ft (305 m) above sea level
4,000 ft - 7,000 ft (1,219 m - 2,134 m)	CO ₂ adjustment with flue gas analyzer required See section 5.4 for instructions.		
Above 7,000 ft (above 2,134 m)	Not approved		

Table 8

3.9 Water connections



Warning: This heater must be supplied with cold potable water. It is not approved for preheated water applications. See chapter 3.12 for approved recirculating application.



Warning: In areas where the water supply has a high mineral content, a water softener is strongly recommended. Damage to the water heater resulting from hard water/scale deposits will not be covered under warranty.

- ▶ When facing the heater, the 3/4" cold inlet connection is on the bottom right and the hot connection is on the bottom left. Centrally locating the water heater is recommended to keep hot water distribution times even throughout the structure.

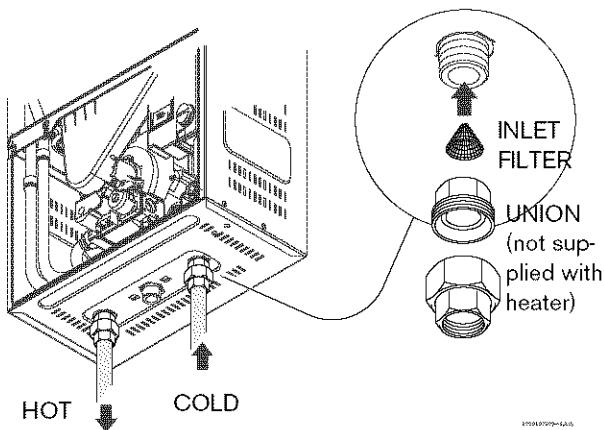

Fig. 25

- ▶ The use of unions when connecting both water pipes to the cold and hot water connections is required. This will facilitate any necessary servicing.
- ▶ Plastic or PEX type plumbing line materials are not suitable for connecting directly to the water heater.
- ▶ Although water piping throughout the building may be other than copper, we recommend that copper or suitably rated stainless steel flex line piping be used for the water connections for 1.5' on either side of the water heater (follow local codes if more stringent).
- ▶ Never sweat any rigid piping directly to or beneath the water connections, as damage can occur to the internal water valve from heating of the pipe.
- ▶ Keep water inlet and outlet pipes to no less than 3/4" (19.05mm) diameter to allow the full flow capacity.
- ▶ If the cold and hot connections to the heater are reversed, the heater will not function. Be certain there are no loose particles or dirt in the piping. Blow out

or flush the lines before connecting to the water heater.

- ▶ Full port shutoff valves should be installed on both the cold water supply and hot water outlet lines to facilitate servicing the heater (see Fig. 26).

Note: If water flow or pressure is low, or heater does not ignite, check the water inlet filter screen for debris (see Chapter 5.1).

Connecting the pressure relief valve (PRV)

A listed pressure relief valve supplied with the heater must be installed at the time of installation. No valve is to be placed between the PRV and the heater. No reducing coupling or other restriction may be installed in the discharge line. The discharge line must be a minimum of 4" above a drain and installed such that it allows complete drainage of both the PRV and the line. The location of the PRV must be readily accessible for servicing or replacement, and be mounted as close to the water heater as possible. See Fig. 26. To install the PRV, a suitable fitting connected to an extension on a "T" fitting can be sweated to the hot water line. Support all piping.

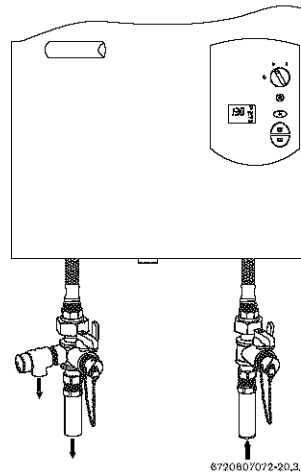

Fig. 26 Plumbing connections (with isolation valves) and pressure relief valve

3.10 Electrical connections

Warning: For safety reasons, disconnect the power supply cord to the heater before any service or testing is performed.

Warning: This heater must be electrically grounded in accordance with the most recent edition of the National Electrical Code NFPA 70. In Canada, all electrical wiring to the heater should be in accordance with local codes and the Canadian Electrical Code, CSA C22.1 Part 1. Do not rely on the gas or water piping to ground the metal parts of the heater.

The GWH-635-ES requires an electrical power supply from a 120VAC / 60Hz circuit (with a dedicated outlet) and must be properly grounded. A means for switching off the 120VAC power supply must be provided. The heater is wired as shown in the wiring diagram (chapter 7, Fig. 44).

3.11 Cascading function

Cascading enables the appliance to be connected in parallel with up to 4 appliances. An appliance in this system will only start, if it gets a signal from the appliance before it. That means, the appliance works always as a Master to the next appliance and always as a Slave to the one before.

For more detailed information about this feature, consult the instructions supplied with the accessory:

- 7 709 003 617.

3.12 Recirculation application

Since recirculation through the heater is not permissible, the following drawing is provided to outline a proper recirculation application using the Aquastar water heater with an Ariston minitank water heater. This schematic is for illustration only and must not be used for actual installation without appropriate engineering and technical advice from a properly licensed professional in the locality where the installation is made.

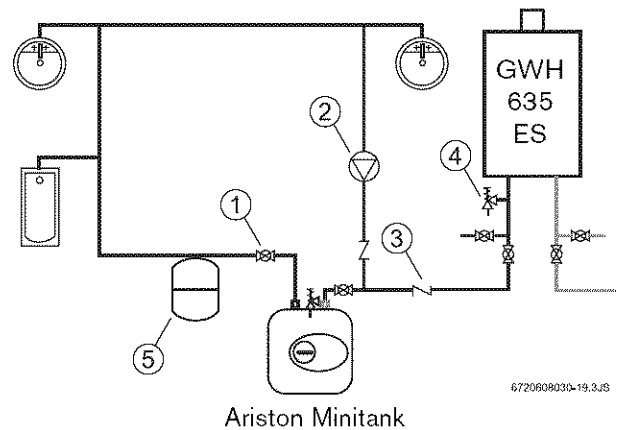

Fig. 27 Recirculation application

- | | |
|---|---------------------------|
| 1 | Full port isolation valve |
| 2 | Circulator |
| 3 | Check valve |
| 4 | PRV |
| 5 | Expansion tank |

The use of a small electric mini-tank water heater (4-6 gallon size) should be used for this application and designed so the pump will circulate the water through the mini-tank and the building's hot water return loop only. Timed or thermostatically controlled operation of the pump is commonly done. The GWH-635-ES must be supplied with cold water only and plumbed in line before the mini-tank water heater. Contact Bosch Water Heating if further information is needed.

4 Operation instructions

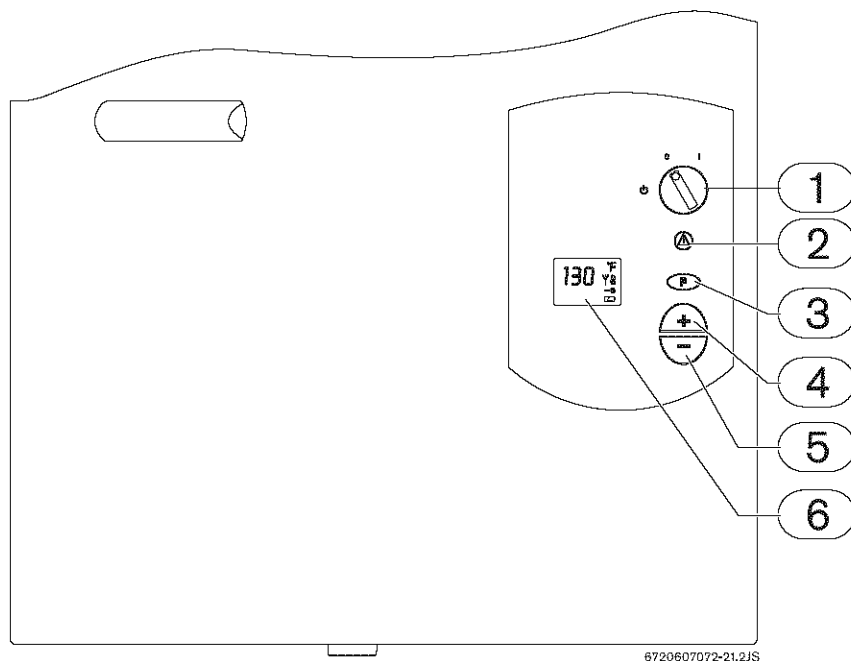

Fig. 28

- 1 On/Off switch
- 2 Reset button
- 3 Program "P" button
- 4 Increasing temperature selector
- 5 Decreasing temperature selector
- 6 LCD display

4.1 For your safety, read before operating your water heater



Warning: The front cover of this appliance must be secured and properly sealed at all times once vent pipe and water connections are made. Failure to do so may result in freezing (not covered under warranty), improper fuel air mixture or error code faults.



Warning: If you do not follow these instructions exactly, a fire or explosion may result causing property damage, personal injury or loss of life.

A. This appliance is equipped with electronic ignition for lighting the main burners. When turning the heater on, follow these instructions exactly.

B. Before operating the unit, set the On/Off switch to the On (I) position.

WHAT TO DO IF YOU SMELL GAS

- ▶ Do not try to light any appliance.
- ▶ Do not touch any electric switch; do not use any phone in your building.

- ▶ Immediately call your gas supplier from a neighbors phone. Follow the gas supplier's instructions.
- ▶ If you cannot reach your gas supplier, call the fire department.

C. Use only your hand to turn the on/off control switch. Never use tools. Follow these instructions exactly. If control switch is jammed, close the gas supply and call Bosch Technical Support. Attempted forceful repair may result in a fire or explosion.

D. Do not use this appliance if any part has been under water. Immediately call a qualified service technician to inspect the appliance and to replace any part of the control system and any gas control which has been under water.

4.2 Power

On

- ▶ To start the appliance move the on/off switch to the "on" position (I).
LCD will display the default temperature factory setting 122°F (50°C).

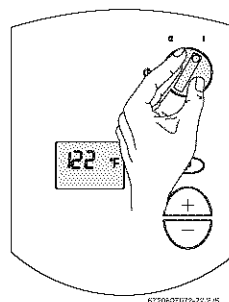



Fig. 29

Off

- ▶ To shut down the appliance move the on/off switch to the "off" position (0).

4.3 Temperature selection

To select output water temperature:

- ▶ Press buttons  and  in order to reach desired temperature.

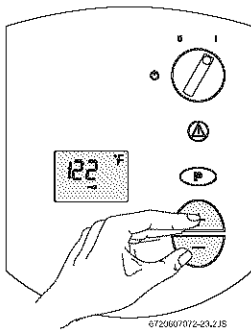

Fig. 30

If the outlet water temperature is set too high, the heater can produce temperatures that are too hot. A temperature balance shower valve will automatically mix in cold water to reduce such hot water temperature. In the event of any temperature fluctuation with the use of a temperature balance shower valve, refer to shower valve manufacturer's instructions for internal adjustment setting. Adjustments should be made to the hottest setting in the shower valve. Additionally the temperature control of the heater can be lowered to produce a more comfortable hot water temperature.

Setting the water temperature

The desired temperature of the hot water can be adjusted on the front control panel of the heater. The GWH-635-ES has an electronically controlled gas valve that modulates the burner input in response to both varying hot water flow rates and/or changes in any incoming and outgoing water temperatures.

Note: selected temperature on heater's display will blink until that temperature has been reached.

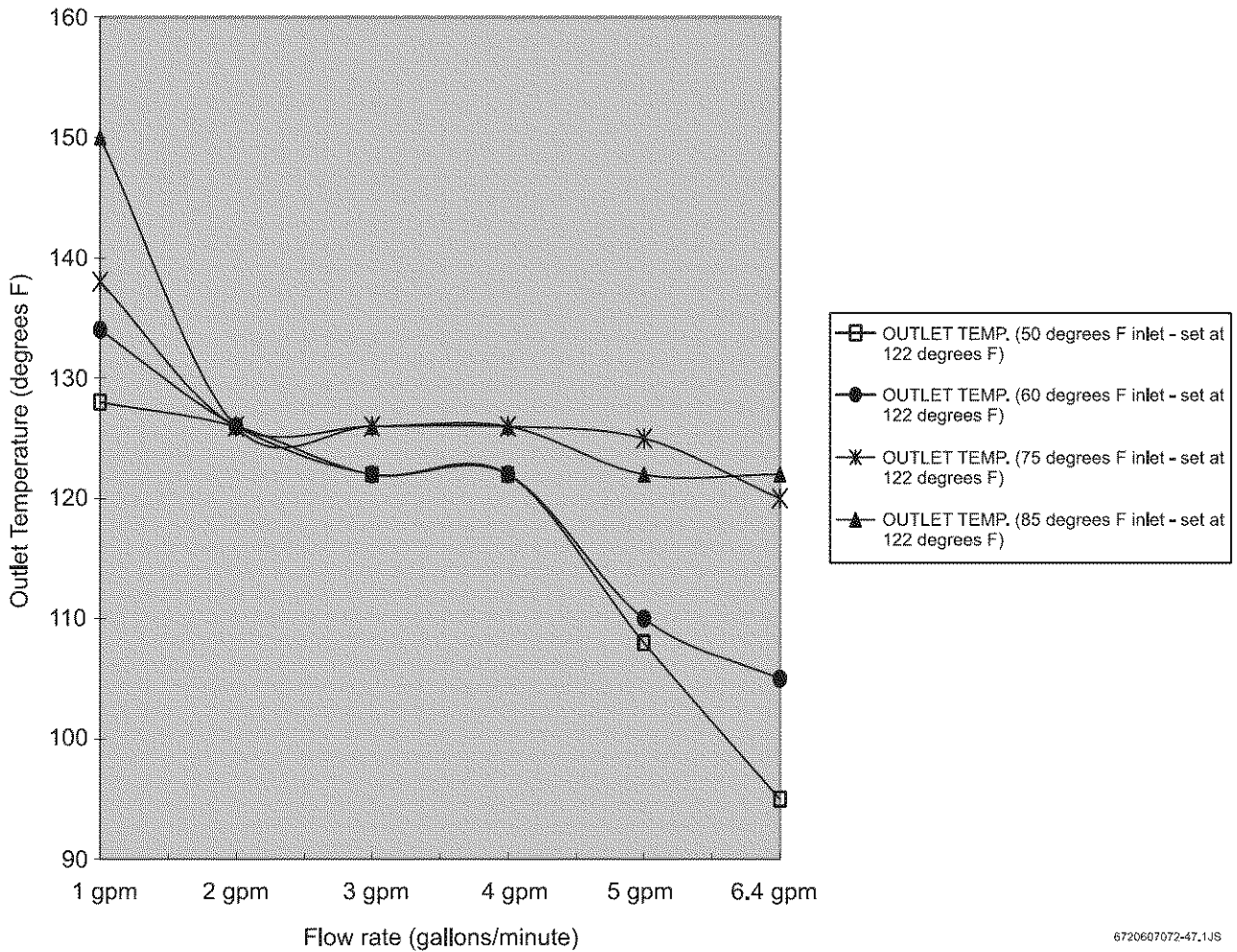

Fig. 31 Flow/temperature chart

Note: Low flowing fixtures are the leading cause of temperature overshoot. To combat this symptom, clean aerators and shower heads or replace with higher flowing fixtures if necessary.

4.4 Use of optional remote control accessory

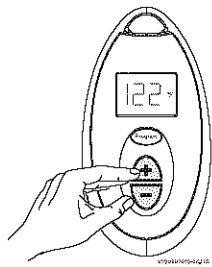

Fig. 32 Remote control

The wireless remote control accessory and the temperature selector buttons on the front of the water heater operate identically. Contact your installer or distributor to order the remote control accessory. Modification of the water heaters interior control unit (Fig. 48, component 25) is required when installing the remote control with this heater.



NOTE: up to 6 remote controls can be programmed for one single water heater, each with a range distance of 98 ft (30 m).

4.5 Operation

- ▶ When a hot water tap is opened, main burner ignites and LCD displays indication .



Fig. 33

- ▶ LCD blinks until selected temperature is reached.

If display blinks continuously, heater cannot maintain or achieve selected temperature.

4.6 Reset button

If the LCD displays the error symbol  and error code do not shut off power or unplug the heater. Record the error code displayed on LCD and consult "Troubleshooting" section (Section 6.8, page 36).

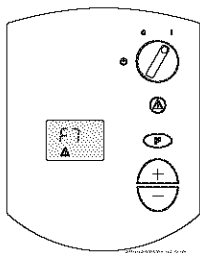

Fig. 34

After following instructions indicated in "Troubleshooting" section:

- ▶ press reset button in order to return heater to normal operation.

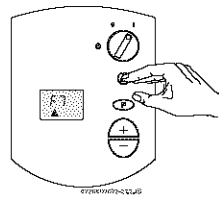

Fig. 35 Reset button

If the problem persists or error code will not reset, contact your installer.

4.7 Program button

The program button can be used on the appliance and on the remote control.

Programming "Program" function

Programming actions are similar for both controls (appliance control pad and wireless remote control).

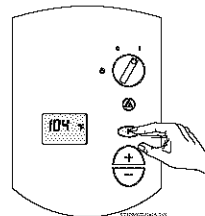





Fig. 36 "Program"  button

- ▶ Press buttons  or  to select temperature to be memorized.
- ▶ Hold "Program"  button for 3 seconds to save temperature.

When LCD stops blinking, selected temperature has been memorized.

Using "Program" function

In order to select memorized temperature

- ▶ Press "Program" key.

LCD shows pre-memorized temperature, which is now the hot water selected temperature.

4.8 Locked condition

This condition is only valid for appliances utilizing one or more remote controls.

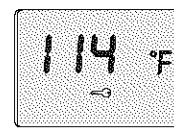



Fig. 37 Locked condition

Whenever LCD shows  the temperature setting cannot be adjusted because the appliance is in use by a user which already selected a different temperature. Appliance will be automatically unlocked after closing hot water tap.

5 Maintenance and service



Warning: Always turn off the electrical power supply, turn off the manual gas valve and turn off the manual water control valves when servicing heater.

The unit should be checked once a year by a gas technician. If repairs are needed, the repairs should be done by a gas technician

5.1 Annual maintenance

(To remove front cover, see page 5.)

Venting System

- Venting system - inspect inside of flue pipe for any blockage or restriction. Observe burner flames during heater operation. Verify that the damper inside flue gas exhaust accessory is able to move freely. (Vent pipe must be removed in order to access damper). Inspect the combustion air inlet pipe for blockage or debris. Inspect combustion air and exhaust terminations for blockage or debris.

Combustion chamber

- Inspect burner observation window (Fig. 46, #10) for cracks or leakage of flue gases. Observe burner flames during heater operation. Flames should be steady and blue with no signs of yellowing. Yellow burner flames are an indication of improper combustion. Refer to Section 3.5 & 3.6 of this manual to verify exhaust system and combustion air supply meets manufacturer's specifications.

Pressure relief valve

- Manually open the pressure relief valve to ensure proper operation.

Inlet water filter

- Verify the inlet filter screen is clean and undamaged. The inlet water filter is located within the 3/4" cold water inlet on the bottom right side of the appliance (See Fig. 25). Close installer supplied cold water shutoff and remove cold water supply pipe. Remove filter, clean or replace if damaged.

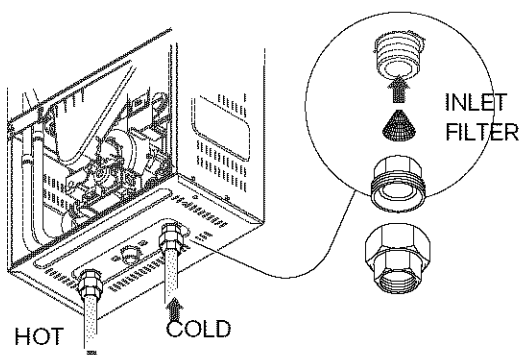

Fig. 38

Descaling

- In areas where the water supply has a high mineral content, the heat exchanger may need to be flushed with a descaling solution. Scale build up will shorten the life of the water heater and damage resulting from scale is not covered under warranty. Refer to section 5.3 for detailed instructions on descaling the heat exchanger.

Heat exchanger

- Inspect heat exchanger fincoil for soot build-up or blockage. To access fincoil, venting must be removed from flue gas exhaust accessory. With venting removed, manually hold open damper and inspect fincoil below with a flashlight. If there is evidence of soot build-up or blockage, the heat exchanger should be removed by a professional and cleaned thoroughly. To remove the heat exchanger, consult service bulletin TWH-G2-22 at www.boschpro.com.

5.2 Winterizing for seasonal use

Please note that installation instructions state that the water heater must not be installed in a location where it may be exposed to freezing temperatures. If the heater must be left in a space which is likely to experience freezing temperatures (less than 36° F), all water must be drained from the heater. If precautions are not taken, resulting damage will not be covered under the warranty. NOTE: Use of agents such as anti-freeze is not recommended as they may cause damage to the water heater's internal components.

1. Turn on/off switch on the water heater to the off (O) position and unplug power supply cord. The display should be blank.
2. Shut off gas supply to heater.
3. Shut off the water supply to the water heater using installer supplied shutoff valve.
4. Open hot water taps to drain and relieve pressure from the plumbing system. If water continues to flow after 5 minutes, a plumbing crossover is present and must be corrected before proceeding.
5. Disconnect inlet and outlet water pipes from the water heater. Place a small bucket underneath the water heater to catch residual water remaining inside the water heater. Save washers for future use.
6. Using an air compressor, blow short bursts of air (100 PSI Maximum) through the inlet water connection until there is no water coming out of the outlet water connection of the heater.
7. Reconnect water fittings and return heater to service when danger of freezing has passed.

5.3 Mineral scale build-up

Periodic descaling may be necessary in areas with high mineral content in the water. Scale buildup in the heat exchanger may result in lower flow rates, error codes of A7 and E9 and boiling sounds in the heat exchanger.

Descaling using a pump

1. Disconnect electrical supply from the water heater.
2. Shut off the water supply to the water heater using (installer supplied) shut-off valve.
3. Open hot water taps to drain and relieve pressure from the plumbing system.
4. Drain water from the unit's heat exchanger by disconnecting inlet and outlet water connections from the heater.
5. Connect a line (A) from the outlet of the circulating pump (installer supplied) to the inlet water fitting on the water heater.
6. Connect another line (B) to the water outlet fitting on the water heater. Route the other end of this line into a descaling reservoir.
7. Using a 3rd line (C) from the descaling reservoir, connect to the inlet side of circulating pump. Install a filter on the end of the line in the descaling reservoir.
8. Make sure all connections are "hand tight."
9. Fill reservoir with descaling solution so both lines inside are submerged. We recommend straight white vinegar. If using a commercial descalant, refer to manufacturer's instructions on dilution with water.
10. Operate the circulating pump.
11. Make sure there are no leaks and the solution is flowing from the descaling reservoir through the heater and returning to the reservoir.
12. Run solution through the heater until the solution returning to the descaling reservoir comes out clear. (Changing to a fresh solution may be necessary during this process).
13. Disconnect all lines and drain all solution from heat exchanger. Properly discard of solution.
14. Position a container below the hot water outlet and reconnect cold water supply. Open cold water supply shut-off valve and flush heat exchanger with clean water.
15. Shut cold water shut-off valve and reconnect hot water line to the water heater.

pipe (approx 1.5" inserted). Avoid air gaps between probe and measuring port as it can alter readings.

16. Reconnect electrical supply to unit, open water isolation valves, and return the unit to service.

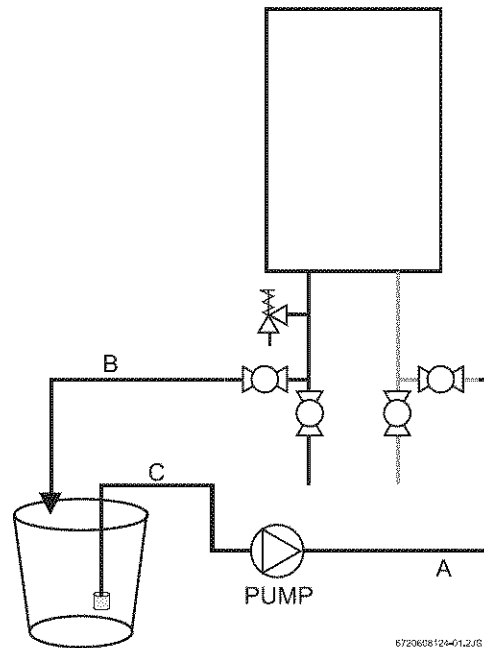

Fig. 39

5.4 Adjusting CO₂

The CO₂ can only be adjusted by a certified gas technician with a calibrated CO₂ analyzer.



Caution: One factor that may affect CO₂ levels is improper gas pressure. Please see Chapter 3.8 for the procedure to measure gas pressure and record your findings below:

Static Gas Pressure: " WC

P1 Operating Pressure: " WC

The P1 minimum operating gas pressure is 5" WC for Natural Gas and 11" WC for Propane. Do not proceed in adjusting CO₂ until pressure is at or above these levels, but not to exceed 14" WC.

A. Once Gas Pressure is adequate

- ▶ Turn ON/OFF switch to the OFF (O) position.
- ▶ Remove brass flat head screw on the exhaust collar as seen in Fig. 40.
- ▶ Insert CO₂ analyzer probe into the measuring port. The tip of the probe should be in the center of the flue

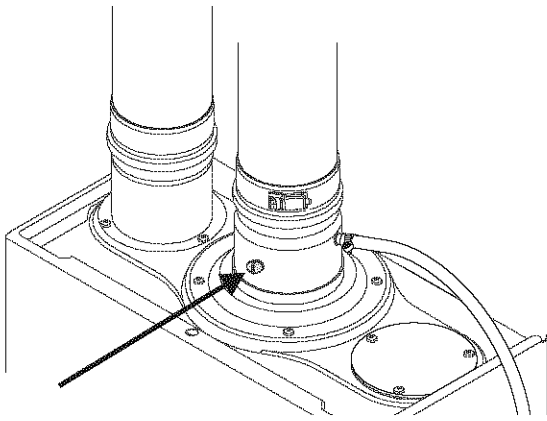

Fig. 40 Measuring port

- ▶ While holding the Program (P) button, turn the ON/OFF switch to ON (I) position (see Fig. 41). As soon as '188' flashes on the display, release the Program button. The display should now read P2. Press Δ button until "P1" appears on display.

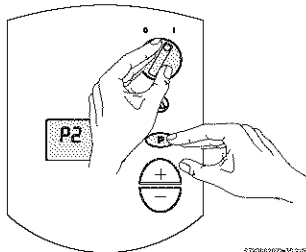

Fig. 41

B. Measuring CO₂ (Cover Installed):

- ▶ Open all hot water taps to achieve a flow rate of at least 4 gallons per minute. (1 tub and 2 sinks should be sufficient).
- ▶ Record the CO₂ reading in P1 below. (Analyzer reading may take several minutes to stabilize).
- ▶ Press the '+' button until P2 appears. Unit will ramp down to low fire and the water flow should decrease.
- ▶ Record the CO₂ reading in P2 below.

P1 CO₂ Reading: % CO₂

P2 CO₂ Reading: % CO₂

C. Adjusting CO₂ (cover removed):

Note: when making adjustments with the front cover off, CO₂ values will be 0.3 - 0.5% lower than with the front cover on. Adjust values accordingly to make target numbers in Table 10 when cover is secured. Compare your readings to those found in Table 10. If CO₂ readings are off, make adjustments as outlined below.

Note: P1 adjustment will change the P2 reading. Confirm the P1 value BEFORE adjusting the P2 level.

		CO ₂ level	Max CO level
Nat. Gas			
max. input	P1	9.7 ± 0.3 %	300 ppm
min. input	P2	9.5 ± 0.5 %	
LP Gas			
max. input	P1	10.7 ± 0.3 %	300 ppm
min. input	P2	10.5 ± 0.5 %	

* Final reading must be confirmed with the front cover on, CO₂ levels increase when the cover is installed.

Table 9

1. If P1 CO₂ level is off:

- ▶ Loosen yellow painted philips screw (1) and cover should rotate down (2) revealing a recessed brass slotted screw. Fig. 42.
- ▶ Turning the slotted screw counter clockwise will raise P1 CO₂ levels and clockwise will lower P1 CO₂ levels. Adjustments to the slotted screw will also change P2 CO₂ levels.
- ▶ After bringing the P1 CO₂ readings in range, press the Δ button to enter the P2 mode. Verify CO₂ readings in P2 mode.

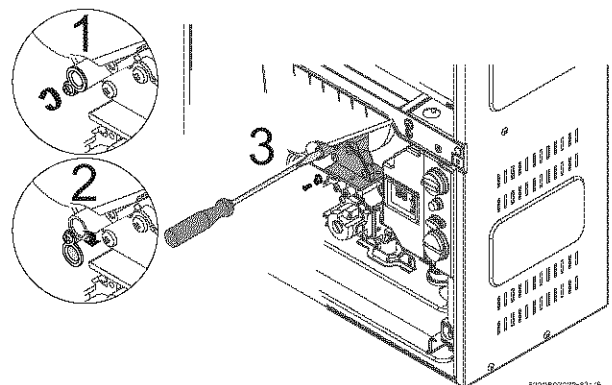

Fig. 42 Adjusting P1 CO₂ level

2. If P2 CO₂ level is off:

- ▶ Remove yellow painted #40 Torx cover from the front of the gas valve. (Fig. 43) A plastic #40 Torx screw will be revealed.
- ▶ Turning the plastic #40 Torx screw counter clockwise will lower P2 CO₂ levels and clockwise will raise P2 CO₂ levels.

Note: These screw adjustment are very sensitive and may take several minutes to stabilize.

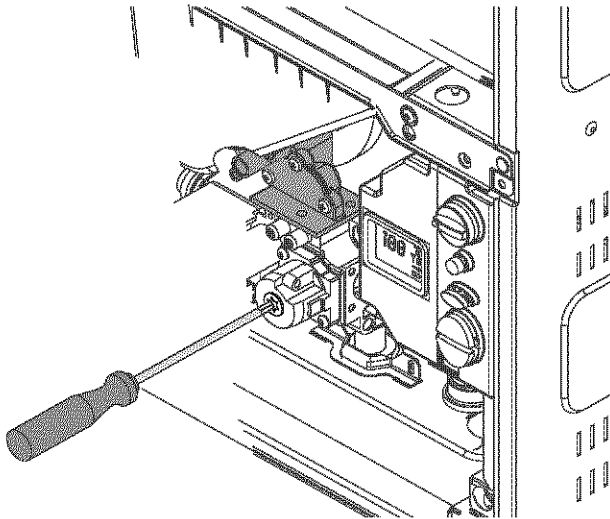

Fig. 43 Adjusting P2 CO₂ level

3. Verify both P1 and P2 CO₂ readings are within the ranges specified in table 10. Repeat steps 1 and 2 as necessary until CO₂ values are within the specified ranges.

4. Once CO₂ values are within the specified ranges, verify the CO readings on P1 do not exceed 300ppm (follow local codes). If values exceed this limit, inspect vent system and fin coils (Chapter 5.1) for blockage.

D. Returning to Service:

1. Return slotted screw cover to original position.
2. Reinstall Torx cover.
3. Remove CO₂ analyzer probe and reinstall flathead screw with gasket in exhaust collar.
4. Install front cover.
5. Turn ON/OFF switch to the OFF (O) position and then back to the ON (I) position.
6. Heater is ready for normal operation.

		CO ₂ level	Max CO level
		Nat. Gas	
max. input	P1	9.7 ± 0.3 %	300 ppm
min. input	P2	9.5 ± 0.5 %	
		LP Gas	
max. input	P1	10.7 ± 0.3 %	300 ppm
min. input	P2	10.5 ± 0.5 %	
* Final reading must be confirmed with the front cover on, CO ₂ levels increase when the cover is installed.			







Table 10

Final Readings





P2 CO₂ Reading: % CO₂

P1 CO₂ Reading: % CO₂

5.5 Control board diagnostics

1. Turn on/off switch on water heater to off (O) position.
2. Press and hold the program () button while turning the on/off switch to the on (I) position. The display will cycle through a startup procedure including the software version.
3. Release the '  ' button when '188' appears on the display. The display should read 'P2' when the program button is released. If not, repeat process.
 - ▶ Press and release the '  ' button on the control panel until the display reads 'P4'. You are now in the diagnostic mode of the control board.
4. When the display reads 'P4', press and release the '  ' button once again and the display should read 'E'.
 - ▶ Use the '  ' and '  ' button on the control board to cycle through different diagnostic modes available.
5. Once in the selected diagnostic mode of your choice, press and release the '  ' button to display the diagnostic information.

EXAMPLE: to read the flow rate in gallons per minute while the unit is flowing water, cycle to the '3d' mode and press the '  ' button. A reading of 25 on the display would indicate the heater is reading a flow rate of 2.5 gallons/minute.

6. Once the information is obtained, press the '  ' button again to return to the diagnostic mode menu and scroll to addition diagnostic information.
 - ▶ To exit the diagnostic mode of the heater, use the '  ' or '  ' button until the display reads 'E'.
7. Press the '  ' button once again and the display should read P4.
8. Turn the on/off switch off (O) and back on (I) again to return heater to normal function.

Diagnostic menu	
E	Entry/Exit into sub-modes
0d	Set-point temperature
1d	Inlet water temperature (F)
2d	Outlet water temperature (°F)
3d	Water flow (gallons/min)
4d	Gas type (LP or NG)
5d	Fan speed (Hz)
6d	Burner power (%)
7d	Maximum power (kW)
8d	PWM cycle (signal to fan)
9d	Appliance selection
1F	Most recent error/failure
2F	2nd most recent error
3F	3rd most recent error
4F	4th most recent error
5F	5th most recent error
6F	6th most recent error
7F	7th most recent error
8F	8th most recent error
9F	9th most recent error
10F	10th most recent error

Table 11

6 Troubleshooting



Warning: If you are unable to perform the tasks listed below, or need additional assistance please contact your original installer/licensed gas technician.

6.1 Introduction

Many of the questions customers ask regarding operation of this unit can be answered by following the troubleshooting steps as outlined below. Visit our web site at www.boschpro.com for more detailed troubleshooting. For best results, perform each step before proceeding to the next. The suggested solutions may require that the cover be taken off. (See Page 5, Fig. 3).

6.2 Burners do not ignite when hot water is turned on

1. If the display is blank, verify power to electrical outlet. (120VAC/60Hz properly grounded circuit required). Verify that the heater on/off switch is in the on (I) position.
2. Verify the fuses in the control unit are good. To access fuses, the control unit must be removed. Go to www.boschpro.com for a detailed service bulletin on this process. Two spare fuses are located inside lower access panel of control unit.
3. Make sure cold water inlet connection is plumbed to the right side of heater when facing unit. See Fig. 25.
4. A minimum of 0.8 gallons per minute (GPM) (3 l/m) is required to activate the heater. A quart container should fill in 20 seconds or less to activate heater.
5. Clean inlet filter screen per chapter 5.2.
6. Inspect the water path for obstructions. Make sure all showerheads, faucet aerators and whole house filters are clear of debris.
7. The heater activates when the water flow through the unit is at or above the required minimum of 0.8 GPM (3 l/m). A crossover creates back pressure on the water flowing through the heater. Therefore, a higher flow rate than normal is needed to force the heater to activate. To check for a plumbing crossover, shut off the cold water supply feed to the water heater. Then open all of the hot water taps served by the heater. Wait 10 minutes and check for water flow at taps. There should be no water flowing. Any continuous flow of water indicates a crossover is present and must be corrected. Consult a professional plumber for help in correcting a crossover. Failing single lever faucets and mixing valves are common causes of plumbing crossovers.
8. With the ON/OFF switch turned to OFF (O) position and the power supply cord unplugged, remove the

unit's front cover (See Page 5, Fig. 3). Check wire connections between the water valve, control unit and electrode set. See chapter 9.2 for location of these parts.

6.3 Water is too hot

1. Selected temperature on the unit is too high. To lower output temperature, see chapter 4.3.
2. Clean inlet filter screen per chapter 5.1.
3. Inspect the water path for obstructions. Make sure all showerheads, faucet aerators and whole house filters are clear of debris.
4. Confirm the heater's gas type coincides with the type of gas being supplied. See Fig. 2 for location of rating plate.
5. This model is designed for cold water supply only. For solar preheated applications, use of the model 125BS is recommended.
6. If the inlet cold water temperature is greater than 70°F due to geographic location avoid restrictive outlets. Clean all showerheads and faucet aerators. It may be necessary to upgrade to higher flow rate fixtures if allowable by local code.
7. In areas where water has a high mineral content, periodic descaling may necessary. See chapter 5.3 for directions.
8. Ensure that both temperature sensors are making contact and firmly mounted on their respective cold and hot water pipes. The hot water sensor should be located on the horizontal section of the hot water pipe before it exits the heater. The cold water sensor is located on the first horizontal section of pipe as the water comes into the heater.

6.4 Water is not hot enough

1. Selected temperature on the unit is too low. To raise output temperature, see chapter 4.3.
2. Clean inlet filter screen. See chapter 5.1.
3. Inspect the water path for obstructions. Make sure all showerheads, faucet aerators and whole house filters are clear of debris.
4. Confirm the heater's gas type coincides with the type of gas being supplied. See Fig. 2 for location of rating plate.
5. Check inlet gas particle screen for blockage at gas inlet connection on bottom of unit.
6. Verify gas pressure is in accordance with specifications in chapter 3.8. A gas pressure reading is needed to proceed further. Contact your original installer or a local certified gas technician to obtain this reading.

7. Cold water is mixing into the hot water lines (plumbing crossover). A plumbing crossover can unintentionally mix cold water with the hot water leaving the heater. The end result is a cooler water temperature than desired. To check for a plumbing crossover, shut off the cold water supply feed to the water heater. Then open all of the hot water taps served by the heater. Wait 10 minutes and check all taps for water flow. There should be no water flowing. Any continuous flow of water, small or large, indicates a crossover and must be corrected. Failing single lever faucets and mixing valves are common causes of plumbing crossovers.
8. Ensure that both temperature sensors are making contact and firmly mounted on their respective cold and hot water pipes. The hot water sensor should be located on the horizontal section of the hot water pipe before it exits the heater. The cold water sensor is located on the first horizontal section of pipe as the water comes into the heater.

6.5 Low water flow/pressure

1. Too many hot water applications are being used simultaneously or too much flow is demanded. The water heater will effectively support two 2.0-2.5 GPM shower heads simultaneously or multiple sink applications. Greater draws will result in a water pressure drop and reduced flow at taps.
2. Ensure that gas pressure is in accordance with specifications in chapter 3.8. A gas pressure reading is needed to proceed further. Contact your original installer or a local certified gas technician to obtain this reading. If gas pressure is inadequate, the water heater will close its motorized water valve, reducing the hot water flow rate in an attempt to reach the selected output temperature.
3. If selected temperature on the unit is set too high for the demanded flow rate, the water heater will close its motorized water valve, reducing the hot water flow rate in an attempt to reach the selected output temperature. Lowering the selected temperature will allow the motorized water valve to open up for increased water flow rate.
4. Clean inlet filter screen per chapter 5.1.
5. Inspect the water path for obstructions. Make sure all showerheads, faucet aerators and whole house filters are clear of debris.

6.6 Hot water temperature fluctuates at tap

Note: Temperature fluctuations from hot to cold during use are typically caused by a restriction in the hot water flow from the tankless heater. This slows the flow within the tankless heater, decreasing it below the activation flow rate, which shuts off the burners. The end result is nothing but cold water coming out of the outlet. Follow

each step below before proceeding to the next. After each step, test the hot water flow to see if it remains constant without turning cold.

1. Check for restrictions in plumbing outlets, which could limit hot water flow and may contribute to heater deactivation. For sinks, remove faucet aerator. Flush and clean screen and reinstall. For showers, remove showerhead and flush. If plugged with mineral deposits, clean according to manufacturer's suggestions or replace shower head. (If showerhead is wand style/hand held, corrugated tube connecting to head may be too restrictive. Use a larger tube or replace with a normal showerhead.)
2. Clean inlet filter screen per chapter 5.2.
3. Check for a plumbing crossover by closing the installer supplied cold water shut off valve (if none installed, install before proceeding) and opening all hot water taps supplied by the heater. Wait 5 minutes and check all taps. The water flow should come to a complete stop at every tap. Any water running, even a trickle, is a sign of a plumbing crossover. Consult a local plumber or service person for help. This condition must be corrected before the heater can operate properly.
4. Confirm water pressure is adequate and constant. Water pressure must stay above 30psi during heater operation. For installation on a private well system with the use of a pressure tank, the lowest pressure range setting recommended is 30-50 psi (2.07-3.45 bar). The use of a pressure reducing/regulating valve directly after the pressure tank is an effective way to maintain constant water pressure to the water heater. Watts brand 25AUB- $\frac{3}{4}$ " or N35B- $\frac{3}{4}$ " pressure reducing/regulating valves or equivalent is suggested.
5. Heater deactivated by temperature balancing valves. If the outlet water temperature is set too high, the heater can produce temperatures that are too hot. A temperature balance shower valve will automatically mix in cold water to reduce such hot water temperature. In the event of any temperature instability at a fixture using a temperature balancing valve, refer to the valve manufacturer for instructions on internal adjustment setting. An adjustment should be made to minimize the amount of cold water the valve is adding. Additionally, the temperature setting on the heater can be lowered to prevent the temperature balance valve from mixing in too much cold.

6.7 Noisy burner/heater during operation

1. Sealed combustion leak. Make sure cover is securely fastened. Ensure the exhaust vent adaptor is properly sealed with supplied gasket. Leaky seals create improper combustion resulting in noise.

2. Improper venting. Venting that is unsealed, the wrong material, too big in diameter or too long in run will result in unstable burner flames and noise. Ensure venting is correct and in accordance with specifications in chapter 3.6.
3. Lack of adequate combustion air. Drawing combustion air from a room area of inadequate size or improper piping of combustion air from the outside will result in unstable burner flames and noise. Ensure adequate combustion air is provided to the unit in accordance with specifications in Section 3.5 Combustion Air Requirements.
4. Cross contamination. Ensure that intake and exhaust terminations maintain required clearances stated in the manual. Cross contamination between intake and exhaust may cause unstable burner flames and noise.
5. Lack of gas pressure. Inadequate gas pressure will cause the fuel-to-air mixture (CO_2) to be out of adjustment. This will result in unstable burner flames and noise. Ensure gas pressure is in accordance with specifications in Section 3.8 Measuring Gas Pressure. A gas pressure reading is needed to proceed further. Contact your original installer or a local certified gas technician to obtain this reading.
6. Verify proper CO_2 readings per chapter 5.4. CO_2 adjustments must be done by a certified gas technician with a calibrated combustion gas analyzer.

6.8 Error code diagnostics

Part numbers subject to change.

Display	Cause	Solution
A2	Fault in the flue gas limiter (part# 8700400032). Note: Old style overheat cutoff fuse (8700400019) has been replaced with this new limiter.	<ol style="list-style-type: none"> 1. Check for flue gas leakage around the top and bottom seals of heat exchanger as well as the viewing window. Look for any noticeable burn marks or warping of the gaskets. If a leak is detected, seals will need replacing. 2. Verify that venting meets specifications outlined in chapter 3.6. Long vent lengths, incorrect venting material, venting with more than three elbows, blocked vent or combination venting may cause this failure. Verify backdraft flapper inside flue gas collector is not stuck shut. 3. Check flue gas limiter wire connectors for tightness. Clean with pencil eraser if any corrosion is evident. 4. Trace wires from flue gas limiter to black connector. Verify the connection is tight. 5. If limiter is tripped due to overheating, it must cool down before error will clear on the control board.
A7	Hot water temperature sensor fault (Temperature below 36°F or above 210°F) (part# 8700400015)	<ol style="list-style-type: none"> 1. Check red wire connections at the hot water temperature sensor. Clean terminals with a pencil eraser. If badly corroded, replace sensor and wire harness. Verify that sensor is firmly clipped on to the hot water copper pipe. 2. Sensor may trip if water temperature drops below 36°F. Protect heater from freezing condition as any damage due to freezing conditions is not covered under warranty. 3. Clean inlet filter screen per chapter 5.1 and clear any debris out of showerheads, faucet aerators and whole house filters. 4. In areas where water has a high mineral content, periodic descaling may necessary. See chapter 5.3 for directions. 5. Swap sensor with the cold water sensor, keeping respective wire connections as they are. If the heater produces an E2 error, replace the sensor.
A9 (Flashing)	Hot water temperature sensor not sensing expected output temperature. (part# 8700400015)	<ol style="list-style-type: none"> 1. Check that the sensor is firmly attached to the horizontal section of the hot water pipe. 2. Clean inlet filter screen per chapter 5.2 and clear any debris out of showerheads, faucet aerators and whole house filters. 3. Verify that venting meets specifications outlined in chapter 3.6. Long vent lengths, incorrect venting material, venting with more than three elbows, blocked vent or combination venting may cause this failure. Verify backdraft flapper inside flue gas collector is not stuck shut. 4. Check gas pressure per chapter 3.8*. Low gas pressure may prevent the heater from reaching desired output temperature. 5. Check supply voltage is 120VAC and is properly grounded. 6. Possible defective control unit. Call Bosch Water Heating for further instructions.

Table 12

* By installer or service technician only.

Display	Cause	Solution
C1	Fan rotation too low on startup. (part# 8707204039)	<ol style="list-style-type: none"> 1. Disconnect power supply cord. Check wire connections on back side of fan and the two large wire connectors on the control unit. Removal of lower access panel on control unit is necessary to access connectors. 2. Verify that supply voltage is 120VAC and is properly grounded. 3. Verify that venting meets specifications outlined in chapter 3.6. Long vent lengths, venting with more than three elbows, blocked vent or combination venting may cause this failure. Verify backdraft flapper inside flue gas collector is not stuck shut. 4. Check gas pressure. See chapter 3.8. Low gas pressure may cause the fan to change its speed to meet desired temperature. 5. Possible defective control unit. Call Bosch Water Heating for further instructions.
C6	Fan rotation too low in operation (part# 8707204039)	<ol style="list-style-type: none"> 1. Disconnect power supply cord. Check wire connections on back side of fan and the two large wire connectors on the control unit. Removal of lower access panel on control unit is necessary to access connectors. 2. Check supply voltage is 120VAC and is properly grounded. 3. Verify that venting meets specifications outlined in chapter 3.6. Long vent lengths, venting with more than three elbows, blocked vent or combination venting may cause this failure. Verify backdraft flapper inside flue gas collector is not stuck shut. 4. Ensure intake and exhaust terminations maintain the required clearances stated in the manual (Fig. 17 and Table 6 on page 17). Cross contamination between intake and exhaust may cause the fan to alter its rotational speed. 5. Check gas pressure. See chapter 3.8*. Low gas pressure may cause the fan to change its speed to meet desired temperature. 6. Possible defective control unit. Call Bosch Water
C7	No rotational speed sensor from fan. (part# 8707204039)	<ol style="list-style-type: none"> 1. Disconnect power supply cord. Check wire connections on back side of fan and the two large wire connectors on the control unit. Removal of lower access panel on control unit is necessary to access connectors. 2. Check supply voltage is 120VAC and is properly grounded. 3. Possible defective component in fan. Call Bosch Water Heating for further instructions.
CA	Water flow signal over specified maximum value. (part# 8708505016)	<ol style="list-style-type: none"> 1. Disconnect power supply cord and check wire connections on water valve and the two connectors on the control board. 2. Excessive water pressure and flow. Ensure water pressure is less than 150psi and flow rate is less than 10 gallons per minute.

Table 12

* By installer or service technician only.

Display	Cause	Solution
E1	Over-temperature detected by temperature sensor on hot water pipe. (part# 8700400015)	<ol style="list-style-type: none"> 1. This water heater must be supplied with cold water for domestic hot water only. Do not recirculate water through this heater or supply with preheated water. 2. Check that the hot water temperature sensor is firmly attached to the horizontal section of the hot water pipe. 3. Check red wire connections at hot water temperature sensor. Clean terminals with an eraser. If badly corroded, replace sensor and wire harness. 4. Swap hot water temperature sensor with the cold water temperature sensor. If the heater produces an E2 error, replace hot water temperature sensor. 5. Clean inlet filter screen per chapter 5.2 and clear any debris out of shower heads, faucet aerators and whole house filters. 6. In areas where water has a high mineral content, periodic descaling may be necessary. See chapter 5.3
E2	Cold water temperature sensor fault. (part# 8700400015)	<ol style="list-style-type: none"> 1. Check blue wire connections at cold water temperature sensor. Clean terminals with an eraser. If badly corroded, replace sensor and wire harness. 2. Verify that the sensor is firmly attached to the horizontal section of the cold water pipe. 3. Sensor will trip if it detects temperatures at or below 36°F. Protect heater from freezing conditions as any damage resulting from freezing is not covered under warranty. 4. Swap cold water temperature sensor with the hot water temperature sensor. If the heater produces an A7 error, replace cold water temperature sensor.
E9	Temperature limiter (ECO) open circuit (should reset when cooler temperatures are detected). (part# 8707206204)	<ol style="list-style-type: none"> 1. This water heater must be supplied with cold water for domestic hot water only. Do not recirculate water through this heater or supply with preheated water. 2. Disconnect power supply cord and check white wire connections on ECO (top right of heat exchanger). Clean terminals with an eraser. If badly corroded, replace sensor and wire harness. 3. Verify that venting meets specifications outlined in chapter 3.6. Long vent lengths, venting with more than three elbows, blocked vent or combination venting may cause this failure. Verify backdraft flapper inside flue gas collector is not stuck shut. 4. Clean inlet filter screen per chapter 5.1 and clear any debris out of shower heads, faucet aerators and whole house filters. 5. In areas where water has a high mineral content, periodic descaling may be necessary. See chapter 5.3 for directions. 6. Unplug power supply cord to the water heater. Open a hot water tap for several minutes to allow cold water to pass through heat exchanger. Close hot water tap and disconnect lead wires to ECO. Using a multimeter, check continuity through ECO

Table 12

* By installer or service technician only.

Display	Cause	Solution
EA	No flame ionization detected with water flow. (part# 8708107020)	<ol style="list-style-type: none"> 1. Verify that all manual gas shut off valves are open. 2. Verify gas type (See Fig. 2) corresponds with the type of gas supplied to the heater. 3. Reset error code and open a water tap to cycle the heater in an effort to purge air from gas line (especially on new installations). Cycling hot water tap on and off multiple times may be necessary. If heater still faults with EA error code, have a licensed gas technician properly purge air out of the gas line leading to the water heater. 4. Verify the three yellow wire connections to the set of electrodes (underside of the burner assembly) are secure. 5. Verify gas pressure meets specifications outlined in chapter 3.8*. 6. Verify venting meets specifications outlined in chapter 3.6. Improper venting may cause premature failure of the flame sensor rod. 7. Observe inside the viewing window of the heat exchanger when a hot water tap is opened. Sparking should be followed by a steady blue flame. If not, Call Bosch Water Heating with observations. Readings from above gas pressure test will be required.
EC	Ionization failure during operation. (part# 8708107020)	<ol style="list-style-type: none"> 1. Verify gas type (See Fig. 2) corresponds with the type of gas supplied to the heater. 2. Verify the three yellow wire connections to the set of electrodes (underside of the burner assembly) are secure. 3. Verify that venting meets specifications per chapter 3.6. Improper venting may cause premature failure of the flame sensor rod. 4. Check gas pressure. See chapter 3.8*. 5. Check and adjust CO₂ readings. See chapter 5.4. 6. Gas valve or flame sensor may be damaged. Call Bosch Water Heating with observations and results of previous steps.
E0	Internal hardware/software failure. (part# 8707207239)	<ol style="list-style-type: none"> 1. Disconnect power supply cord and check the two wire connectors on the control board. 2. Pushing the wrong combination of buttons on the control unit can create confusion among the microprocessors inside. In this case, the error code should not happen more than once or twice. Turn off the water heater. Turn water heater back on and reset error code. Only use the reset button () to reset any error codes. 3. Possible defective control unit call Bosch Water Heating for further instructions.

Table 12

* By installer or service technician only.

Display	Cause	Solution
F7	Ionization error at standby. (part# 8708107020)	<ol style="list-style-type: none"> 1. Loose connection to the flame ionization rod. Verify that the thinner yellow wire leading from the control unit is securely connected to the set of electrodes located at the bottom right-hand side of the heat exchanger. 2. Flame ionization rod or control unit may be damaged. Contact Bosch Water Heating for further instruction.
FA	Gas leakage error, gas valve circuit not closing properly. (part# 8707021019)	<ol style="list-style-type: none"> 1. Disconnect power supply cord and check wire connections on gas valve and the two connectors on the control board. 2. Flow water out of a hot water tap above the minimum activation point of .8GPM. Measure voltage at the gas valve wire connector. The connector should measure 24VDC between the left pair of wires and 24VDC between the right pair of wires when the unit is operating. If voltage is not correct, contact Bosch Water Heating for further instruction. 3. Gas valve may be defective, contact Bosch Water Heating for further instruction.
8E	Electronic noise on control unit. (part# 8707207239)	<ol style="list-style-type: none"> 1. Improper resetting of other error codes. Using the on/off switch or unplugging the power cord to reset error codes can interrupt signal between microprocessors inside control unit and show 8E on the display. Only use the reset button () to reset any error codes. 2. Possible defective control unit call Bosch Water Heating for further instructions.

Table 12

** By installer or service technician only.*

7 Electrical diagram

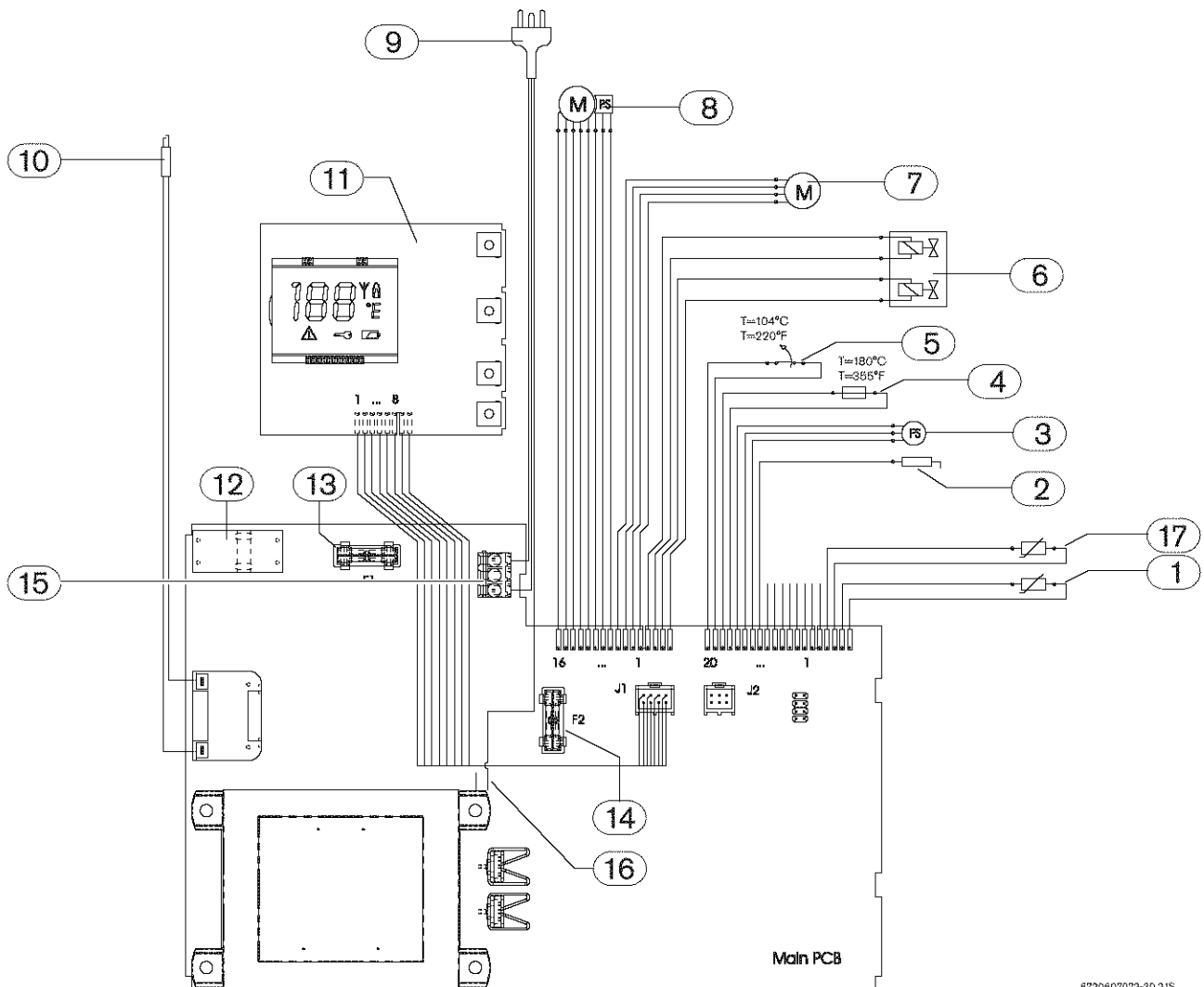

6720607072-30,2/5

Fig. 44 Electrical scheme

- 1 Inlet water temperature sensor
- 2 Ionization sensor
- 3 Water flow sensor
- 4 Flue gas limiter
- 5 Temperature limiter / ECO
- 6 Gas valve
- 7 Fan
- 8 Water valve
- 9 AC Plug
- 10 Ignition electrode
- 11 Display PCB
- 12 ON/OFF switch
- 13 Fuse T 2.5A
- 14 Fuse T 3.15A
- 15 Terminal block
- 16 Ground post
- 17 Outlet water temperature sensor

8 GWH-635-ES Functional scheme

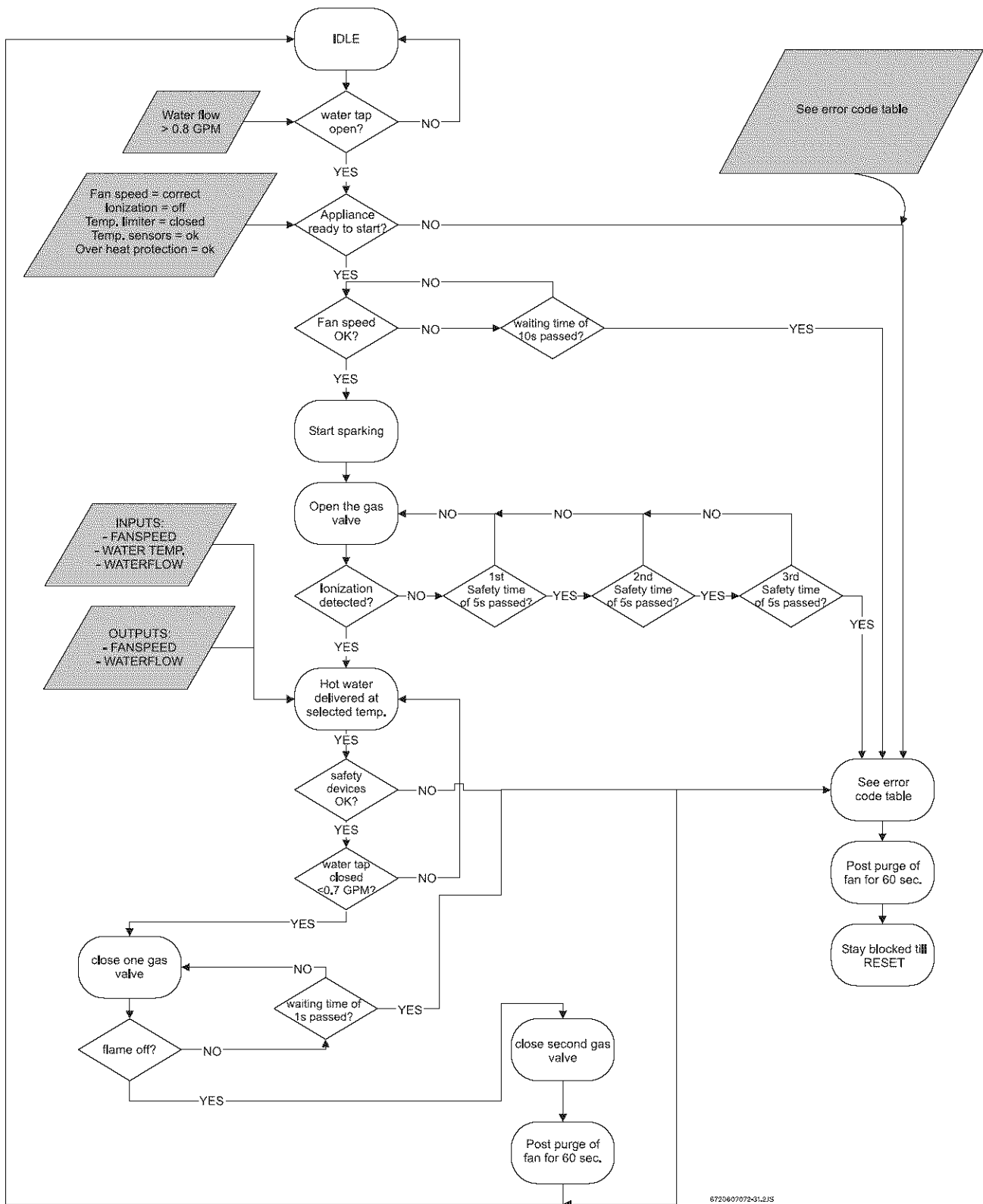

Fig. 45 Functional scheme

9 Interior components diagram and parts list

9.1 Interior components

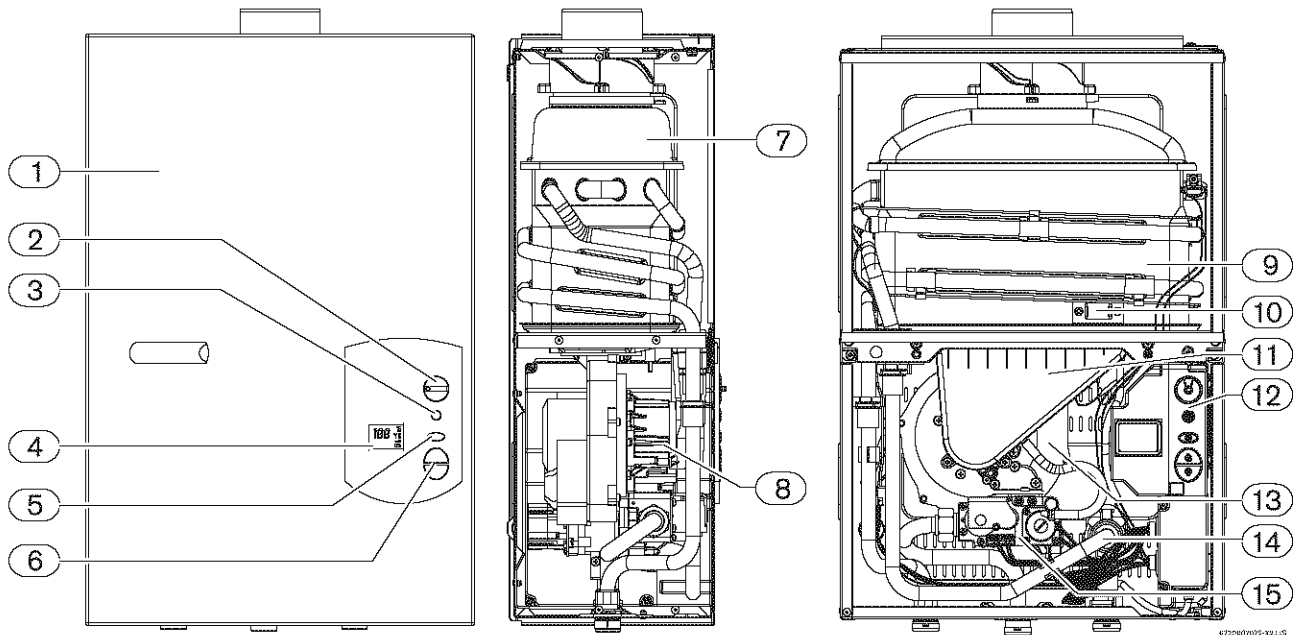

Fig. 46 Components

- 1 Cover
- 2 On/Off switch
- 3 Reset button
- 4 LCD display
- 5 Program button
- 6 Temperature switches
- 7 Flue gas collector
- 8 Mixer
- 9 Heat exchanger
- 10 Observation window
- 11 Inlet air duct
- 12 Control unit
- 13 Exhaust fan
- 14 Water valve
- 15 Gas valve

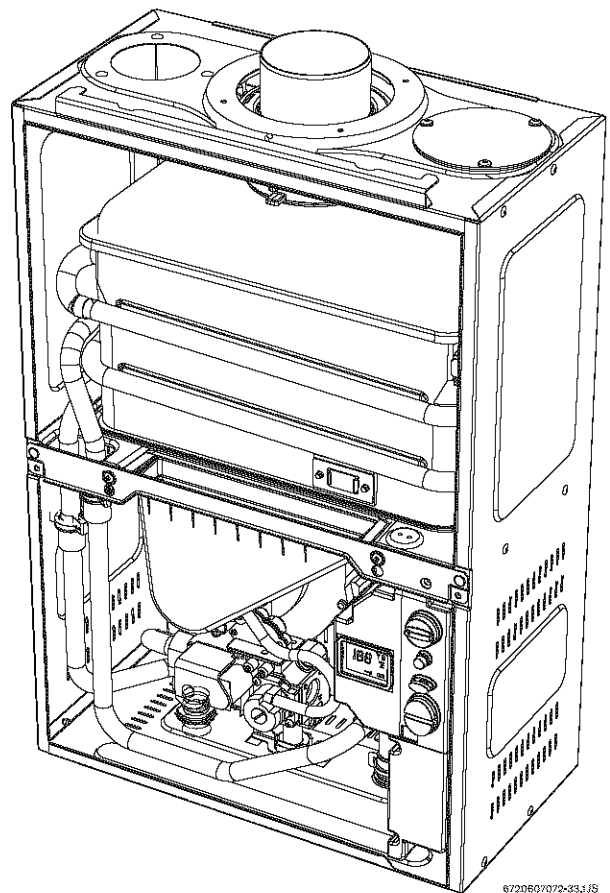

Fig. 47 Appliance overview

9.3 Parts list

Item	Description	Reference
1	Front cover	8 705 421 837
2	Shield	8 705 506 661
3	Heat exchanger	8 705 406 285
4	Heat exchanger top gasket	8 704 701 052
5	Clip	8 716 102 607
6	Heat exchanger bottom gasket	8 704 701 054
7	O-ring	8 700 205 147
8	Temperature sensor	8 700 400 015
9	Washer 1/2"	8 710 103 045
10	Wireform spring	8 714 606 002
11	Air inlet duct	8 705 700 097
12	Water filter	8 700 507 001
13	O-ring	8 700 205 134
14	Water valve with engine	8 708 505 023
15	Main burner	8 708 120 515
16	Fan / Burner gasket	8 704 701 050
17	Set of electrodes	8 708 107 020
18	Exhaust Fan	8 707 204 039
19	Gas / Air Mixer	8 705 700 115
20	Mixer / Fan gasket	8 704 701 059
21	Gas valve washer	8 704 701 062
22	Gas valve	8 707 021 019
23	Gas valve washer	8 700 103 014
24	Remote control (optional accessory)	TSTAT2
25	Control unit	8 707 207 268
26	Ignition cable	8 704 401 220
27	Cables / 24V	8 704 401 214
28	Cables	8 704 401 314
29	Power supply cord	8 704 401 221
30	Flue gas limiter	8 700 400 032
31	Flue gas exhaust accessory	8 705 504 137
32	Combustion air inlet accessory	8 705 504 115
33	Flue gas collector	8 705 700 100
34	Flue gas collector collar	8 705 700 114
35	Cold water pipe	8 700 715 156
36	Hot water pipe	8 700 715 155
37	Attenuator	8 705 700 142
38	Crossover tube	8 700 715 247
39	Overheat sensor (ECO)	8 707 206 204
40	Clip - Heat exchanger	8 701 201 028
42	Gasket Exhaust	8 700 103 710
43	Gasket Set Combustion Chamber	8 704 701 046
44	O-ring air duct	8 700 205 149
45	"BOSCH" decal	8 701 103 124
46	Cold water connection bushing	8 703 305 295
47	Hot water connection bushing	8 703 305 297
48	Mounting bracket	8 708 003 134

Table 13

10 Protecting the environment

Packing

The packing box may be fully recycled as confirmed by the recycling symbol .

Components

Many parts in the heater can be fully recycled in the end of the product life. Contact your city authorities for information about the disposal of recyclable products.

Saving water resources:

- ▶ Make sure you close all the taps after any use. Avoid leaving the taps dripping. Repair any leaking tap.
- ▶ Define the temperature you want, in the appliance or with the remote control. This way you have the precise water flow needed (mixing cold water to regulate temperature will increase the water flow with consequent waste of water).

11 Fifteen Year Limited Warranty

General

BOSCH PRO tankless water heaters are warranted by the Manufacturer (BOSCH) through **BBT** North America. **BBT** North America (BBTNA) will furnish a replacement heat exchanger and will furnish a replacement of any other part which fails in normal use and service within the applicable periods specified below, in accordance with the terms of this warranty. The BBTNA replacement will be warranted for the unexpired portion of the original warranty. This warranty will be valid only for water heaters in possession of the original purchaser as recorded on the warranty card.

The Heat Exchanger

If the heat exchanger fails within fifteen (15) years after the original installation and operation, BBTNA will furnish a replacement heat exchanger. However, if the water heater is installed in other than a single family dwelling, this heat exchanger warranty is limited to two (2) years from date of original installation and operation.

Exceptions

This warranty will not apply:

- **1.** to defects or malfunctions resulting from failure to properly install, operate or maintain the unit in accordance with the printed instructions provided;
- **2.** to damage or abuse resulting from accident, neglect, flooding, freezing and/or other acts of nature;
- **3.** to damage resulting from operation with either the flame sensor rod or overheat sensor removed;
- **4.** to failure of the heat exchanger resulting from the operation of the water heater in a corrosive atmosphere or at water temperatures exceeding the maximum rating, or if the water heater is not supplied with potable water;
- **5.** to defects or damage cause by any attachment or modification, including any energy-saving device.
- **6.** to damage resulting from scale deposits and/or highly mineralized / unsoftened water supply
- **7.** to damage resulting from supplying the water heater with pre-heated water.

All Other Parts

If any other part fails within three (3) years after original installation and operation, BBTNA will furnish a replacement part free of charge.

Shipping costs

In addition to supplying the replacement part(s), BBTNA will provide ground service delivery for these parts. Expedited or upgraded shipping will be charged to the customer.

Service Labor Costs

This warranty does not cover any labor costs associated with service, removal or re-installation of part(s). All such costs must be borne by the Purchaser. Additionally, this warranty does not cover any labor costs associated with service, removal or re-installation of the original water heater or a replaced water heater. Certain service labor allowances are available to PHCC member contractors, dependent on prior authorization by BBTNA.



NOTE: the water heater must be free of damaging scale deposits and not subject to gas pressures greater than those shown on the rating plate, which must not be altered, defaced or removed.

How to Make a Claim

Any claim for warranty parts should be made to your local dealer, distributor or to BBTNA. If BBTNA, please contact the Technical Support Department:

BBT NORTH AMERICA

Bosch Group
340 Mad River Park
Waitsfield, VT 05673

Phone 866-330-2730
www.boschpro.com

In most cases, the dealer or distributor will be able to promptly honor your claim and subsequently notify BBTNA. However, all replacements are made subject to validation by BBTNA of in-warranty coverage. The damaged or defective item must be made available in exchange for the replacement.

Miscellaneous

No one is authorized to make any other warranties on behalf of BBTNA. It is expressly understood that the replacement warranty of BBTNA shall be in lieu of any and all other warranties, express or implied, including warranties of merchantability or fitness for a particular use or purpose, and further that BBTNA shall not be liable for any loss or damage directly or indirectly arising from the use of the hot water heater, or for any consequential damages arising from such use (including damages from water leakage). BBTNA sole liability with respect to any defect shall be for the replacement of the defective part(s). Some states do not allow such limitations and exclusions, so the above may not apply to you.

This warranty gives specific legal rights. You may also have other rights which vary from state to state.

Installer Checklist, to be performed by installer upon installation

Serial Number _____

(8 digit serial number is located on rating plate on right side panel)

Gas Pressure Reading*

Static _____ Operating _____

Building Water Pressure _____

Range if on Well system _____

Installing Company _____

Installer name _____

Address _____

Phone _____

* See Chapter 3.8 and gas pressure table (to be filled out by installer)

Installation manual should be left with the owner after the installation is tested and completed

BBT NORTH AMERICA
Bosch Group

Bosch Water Heating
50 Wentworth Avenue
Londonderry, NH 03053
Phone 866-330-2730
Fax (802) 496-6924
www.boschpro.com
techsupport@boschpro.com

BBT Termotecnologia Portugal S.A.
Estrada de Cacia
3801 - 856 Aveiro - PORTUGAL