

BOWFLEX[®]XTREME²

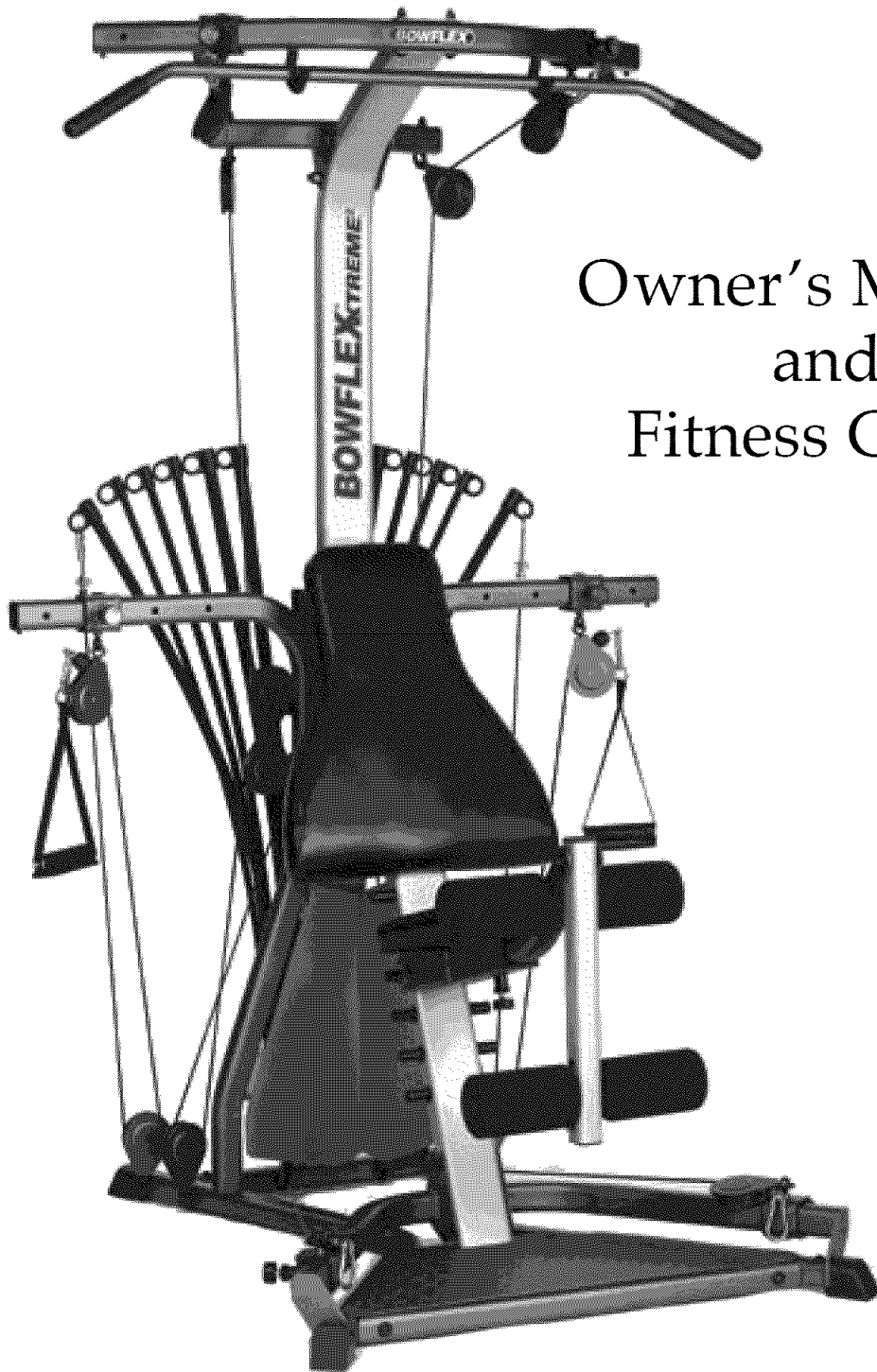

Owner's Manual and Fitness Guide

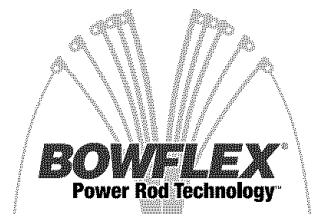

Table of Contents

Get To Know Your Machine	1	Arm Exercises:	
How to Use Your Machine	2	Triceps Pushdown w/ Hand Grips	34
Warning	5	Triceps Hammer Pushdown	34
Define Your Goals	6	Triceps Pushdown w/ Lat Pulldown Bar	35
Working Out	9	Single Arm Pushdown	35
The Workouts	9	Triceps Extension	36
		Cross Triceps Extension	36
Chest Exercises:		Hammer Triceps Extension	37
Bench Press	15	“Rope” Pushdowns	37
Chest Fly	15	Seated Biceps Curl	38
Decline Bench Press	16	Standing Biceps Curl	38
Incline Bench Press	16	Concentration Biceps Curl	39
Decline Chest Fly	17	Hammer Biceps Curl	39
Incline Chest Fly	17	Barbell Biceps Curl	40
		Reverse Barbell Biceps Curl	40
Shoulder Exercises:		Seated Hammer Biceps Curl	41
Crossover Rear Delt Rows	18	Reverse Curl	41
Crossover High Rear Delt Rows	18	Triceps Kickback	42
Reverse Fly	19	Hammer Triceps Kickback	42
Crossover Reverse Fly	19	Arm Opposition Push-pull	43
Seated Shoulder Press	20	Upper Body Opposition Push-pull	43
Front Shoulder Raise	20	Wrist Extension	44
Shoulder Extension	21	Wrist Curl	44
Shoulder Shrug	21	Resisted Dip	45
Scapular Protraction	22		
Scapular Depression	22	Abdominal Exercises:	
Lateral Shoulder Raise	23	Seated (resisted) Abdominal Crunch	46
Seated Forearm Lateral Shoulder Raise	23	Seated (resisted) Oblique Abdominal Crunch	46
Shoulder Rotator Cuff (internal)	24	Trunk Rotation	47
Shoulder Rotator Cuff (external)	24		
Crossover Seated Rear Delt Rows	25	Leg Exercises:	
Scapular Retraction	25	Leg Extension	48
		Squat	48
Back Exercises:		Calf Raise	49
Good Morning	26	Single Leg Calf Raise	49
Standing Low Back Extension	26	Standing Hip Extension (knee bent)	50
Bent Rear Delt Row	27	Standing Hip Extension (knee extended)	50
Crossover Bent Rear Delt Row	27	Standing Hip Abduction	51
Seated Wide Lat Pulldowns	28	Standing Hip Adduction	51
Narrow Pulldowns w/ Lat Pulldown Bar	28	Leg Kickback	52
Narrow Pulldowns w/ Hand Grips	29	Hip Flexion	52
Reverse Grip Pulldowns	29	Dead Lift	53
Crossover Wide Pulldowns	30	Stiff Leg Dead Lift	53
Crossover Narrow Pulldowns	30		
Pulldowns	31	Fast Fat Loss Now!	
Stiff Arm Pulldowns	31	By Ellington Darden, Ph.D	55
Standing Shoulder Pullover w/ Hand Grips	32		
Crossover Seated Lat Rows	32	Bowflex® Xtreme^{2™} Home Gym	
Seated Lat Rows	33	6-Week Satisfaction Guarantee	64
Reverse Grip Pulldown with Lat Bar	33	Home Gym Warranty Card	65
		Home Gym Warranty	67
		Exercise Log	68
		Muscle Chart	69

Get To Know Your Machine

CONGRATULATIONS on your commitment to fitness! With the Bowflex® Xtreme^{2™} Home Gym as your exercise partner, you have the means to exceed all of your physical fitness, strength and health expectations!

Bowflex's innovative design, exceptional resistance and quality is unmatched by any other single piece of home fitness equipment available. You will not believe the amazing results your body will get with the Bowflex® Xtreme^{2™} home gym!

In this Owner's Manual you'll find powerful body-building exercises, leanness-enhancing workouts and a Fast Fat Loss eating program customized to give you *extreme* results!

Please take your time to read through the entire manual before attempting to use your Bowflex® Xtreme^{2™} home gym. You should understand how to properly set up and perform each exercise before you do so using Power Rod® Resistance.

With all of the fitness choices available today, finding the best workout equipment for your needs can be confusing. Everyone at Nautilus would like to congratulate you and thank you for selecting the Bowflex® Xtreme^{2™} home gym. Bowflex is the best home fitness product available, and you're just about to prove it to yourself.

Again, thank you for choosing Bowflex.

The BOWFLEX® Xtreme^{2™} Home Gym

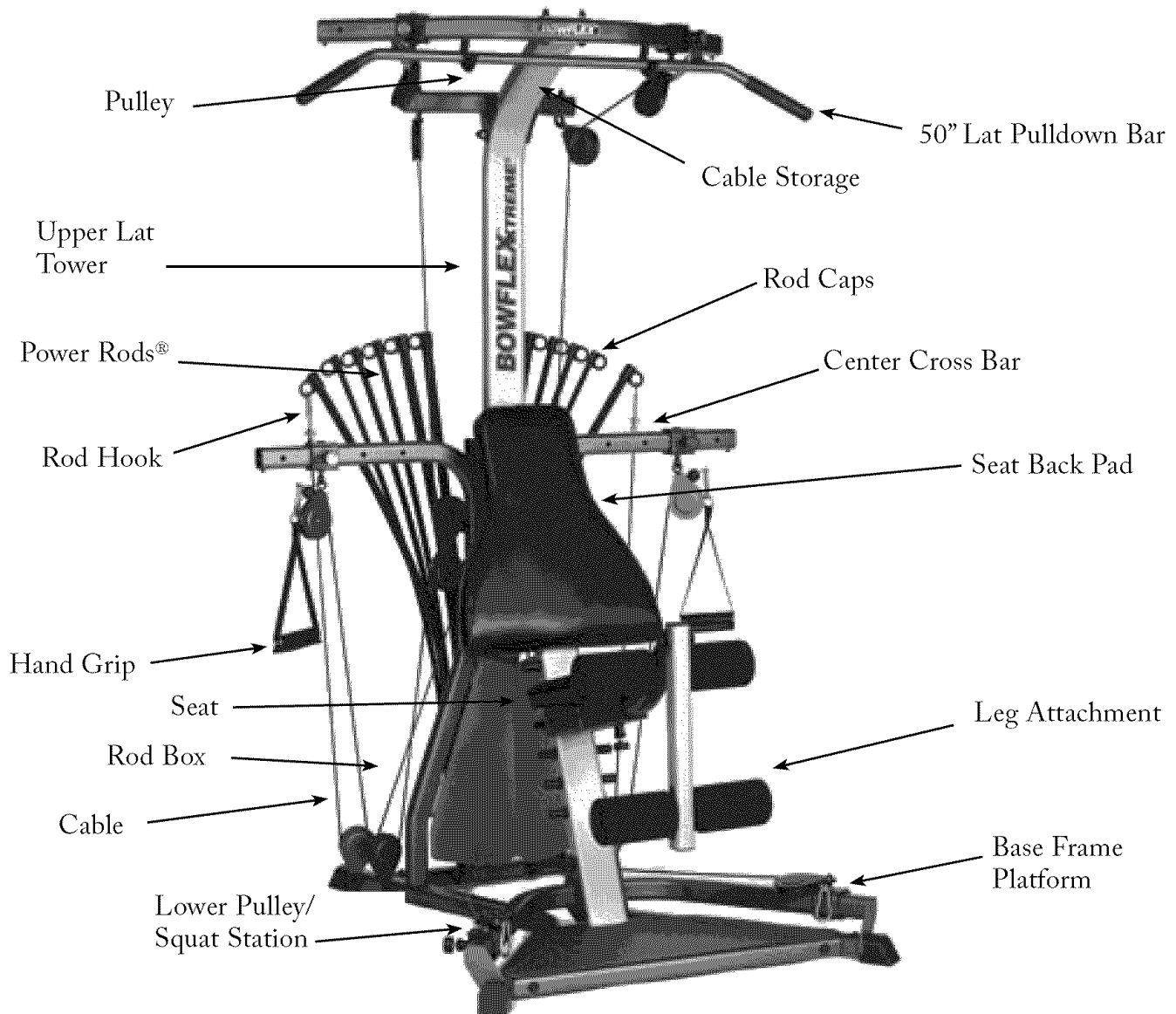

How to Use Your Machine

Power Rod® Resistance

Power Rods are made from a special composite material. Your rods are sheathed with a protective black rubber coating. Each rod is marked with its weight rating on the “Rod Cap”.

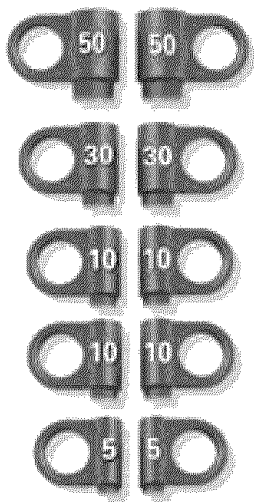

Adjusting And Understanding The Resistance

The standard Bowflex® Xtreme^{2™} home gym comes with 210 pounds of resistance (one pair of 5 pound rods, two pair of 10 pound rods, one pair of 30 pound rods, and one pair of 50 pound rods).

If you upgraded to a 310 or 410 pound capacity

you will have an additional one or two pair of 50 pound Power Rods®, respectively.

Hooking The Power Rods® To The Cables

You may use one rod or several rods in combination, to create your desired resistance level.

To hook multiple rods up to one cable, bend the closest rod toward the cable and place the cable hook through that rod cap. You can then hook up the next closest rod through the same cable hook.

Hooking up the closest rod first prevents rods from crossing over the top of one another.

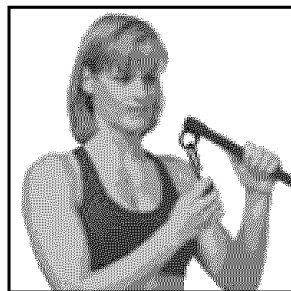
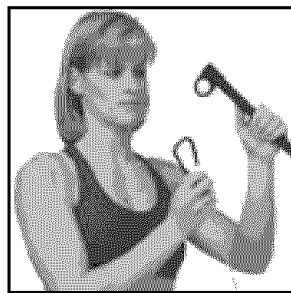

Storing the Bowflex® Xtreme^{2™} Home Gym

Disconnect the cables from the Power Rods® when you are not using your Bowflex® Xtreme^{2™} home gym. Use the rod binding strap included with your machine to bind all the rods together at the top. You can also place your cables and grips through the strap to keep them out of the way.

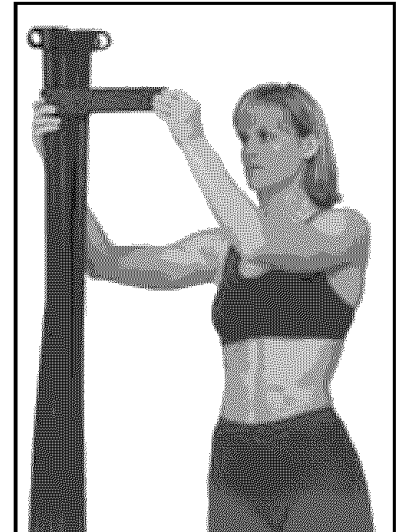

To Order Additional Sets Of 50 lb. Power Rods® Please Call 1-800-269-3539

Safety

When hooking the Power Rods® to the cable hooks, do not stand directly over the tops of the rods. Stand off to one side when connecting and disconnecting the Power Rods® from the cables.

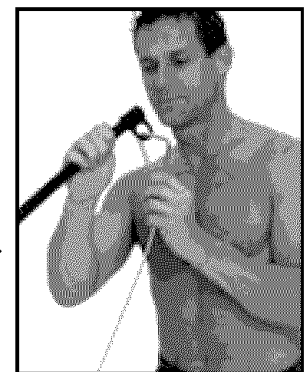

The Bowflex® Xtreme^{2™} Home Gym Pulleys

With the versatility to perform over 75 different exercises, the Bowflex® Xtreme^{2™} home gym is designed to give you the best workout possible. And with its innovative, easy-to-use multiple pulley system, you are guaranteed to maximize every exercise for every muscle group.

There are a few things you will need to remember to get the most from your Bowflex® Xtreme^{2™} home gym Pulleys:

Slider Pulleys

The Bowflex® Xtreme^{2™} home gym comes with adjustable “Slider” pulleys which can be personalized for your body by adjusting them to widths that fit your unique physique. There are Slider Pulleys on the Lat Tower (2 positions per side), Center Cross Bars (4 positions per side) and the Squat Pulley Frame (4 positions per side).

You will need to determine which Pulley positions are most comfortable for you when performing ‘Standard’ exercises, and then adjust the pulleys outward or inward to perform exercises in ‘Wide’ or ‘Narrow’ positions. Using the Slider Pulleys at wider or narrower positions for an exercise can target different parts of the same muscle group and increases the benefit of each exercise.

Pulley Locations

Below is a guide to the five different pulley locations used to perform a full workout routine:



Center Cross Bar:
Used when performing exercises like a Bench Press or Chest Fly.

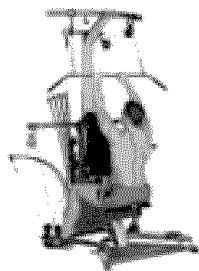

Lat Tower:
Used for exercises like Pulldowns and Pushdowns.

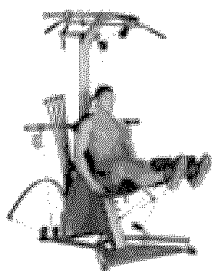

Leg Extension:
Used for leg exercises.

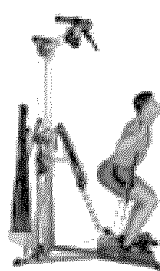

Squat:
Used for the Squat, Dead Lift, Bent Rows, etc.

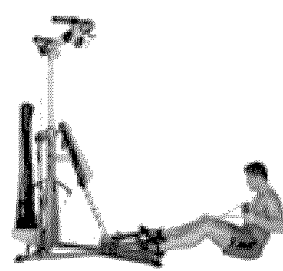

Rowing Position:
Used exclusively for Rowing to strengthen the back.

Maintenance & Care Of Your Bowflex® Xtreme^{2™} Home Gym

Your Bowflex® Xtreme^{2™} home gym requires very little maintenance. To keep your Bowflex® Xtreme^{2™} home gym in top condition, check all fasteners before each workout and tighten as needed.

Clean the seat with a non-abrasive cleaner after each use. This will keep it looking new. Any non-abrasive household cleaner or soap works well. Many automotive interior cleaners make surfaces too “slick” and should not be used.

If you have any questions regarding maintenance please call a Nautilus Representative at 1-800-269-3539.

Hand Grip: The Hand Grips fit snugly around your ankle, instep or wrist. Attach the pulley cable clips to the D-Rings on the Hand Grips to attach them to the cables.

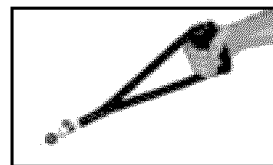

Standard Grip: Grasp the handle and cuff together to form a grip without inserting your hand through the cuff portion. Most of the exercises you perform utilize this grip. The Standard Grip also is used for Hammer Grip exercises, when you need to hold the hand grip vertically for greater wrist support.

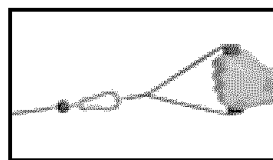

Hand Cuff Grip: Slip your hand through the cuff portion of the Hand Grip so that the foam pad rests on the back of your hand. Then grasp the remainder of the grip that is sitting in your palm. This method of gripping is great for exercises like front shoulder raises or any exercise where your palm is facing down.

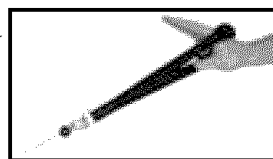

Ankle Cuff Grip: The cuff opening can be enlarged to accommodate the ankle. Insert your hand in the cuff and slide it away from the handle. Insert your foot or ankle through the grip, and then tighten by sliding the handle back toward the cuff.

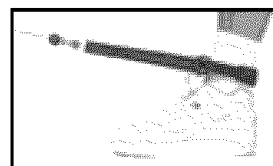

Arch Cuff Grip: The cuff opening can also fit securely over the arch of your foot. For this grip, insert your foot through the cuff until it is around the arch of your instep, and tighten the cuff around your heel to secure the grip.

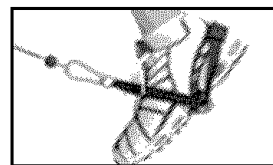

Shoulder Grip: Spread open the cuff and slide the grip up your arm, tightening the grip around your shoulder by pulling the handle toward the cuff.

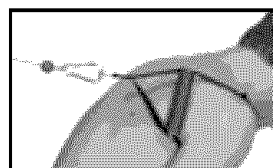

Lat Cross Bar: The Lat Cross Bar enhance exercises that work back, shoulders and triceps muscles.

- Safety:*
- Before using the the Lat Cross Bar, make sure that all fasteners are in place and tightened.
 - Make sure that the Lat Tower cables are securely fastened to the regular Bowflex® cables and the Lat Pulldown Bar, Squat Bar or Hand Grips.
 - Always use the Lat Pulldown Bar holders to support the Lat Pulldown Bar, or remove the bar when not in use.
 - Do not hang from or attempt to perform “chin ups” from the Front Lat Cross Bar.
 - Never pull on the Lat Pulldown Bar unless there is resistance attached to it.

Leg Extension: Designed to add more effectiveness to exercises that target your legs, thighs, calves, etc.

- Safety:*
- Before using the Leg Extension, make sure that all fasteners are in place and tightened.
 - Make sure that the Extension's cables are securely fastened to the regular Bowflex® cables.
 - Always use the Leg Extension Pin to secure the attachment to your Bowflex® Xtreme^{2™} home gym.

WARNING!

Before beginning any exercise program, consult your physician or health care professional. Only he or she can determine the exercise program that is appropriate for your particular age and condition. If you experience any dizziness or shortness of breath while exercising, stop the exercise and consult your physician.

For Your Safety Please Follow These Instructions

Keep your body weight centered on the Seat or Standing Platform while exercising.

When using the Bowflex® Xtreme^{2™} home gym for standing leg exercises, always grasp the Center Cross Bar on your machine for stability.

Keep out of the path of the Power Rods® during exercise and make certain that observers also stand clear of the Power Rods® while they are in use.

Never move or adjust the Seat while sitting on it. Never stand on the Seat.

Never attempt to exercise with more resistance than you are physically able to handle.

Keep cables and Power Rods® bound with the rod binding strap when your Bowflex is not in use.

Inspect your machine before each workout. Periodically check all hardware and fasteners to make sure none have loosened with use. Tighten if necessary.

When hooking up Power Rods® do not stand directly looking over the top of the rods. Stand off to the side while attaching rods.

Before exercising, make sure the cable pulley system is properly secured, properly attached, and in perfect working condition.

All exercises in this manual are based on the calibrated resistance and capacity levels of the Bowflex® Xtreme^{2®} home gym. Any exercises not described in this manual are not recommended by the manufacturer.

Strength Training Equipment Safety Warnings

1. Never allow children to use the Bowflex® Xtreme^{2™} home gym unsupervised. To do so could result in injury. This equipment is under no circumstances suitable as a children's toy.
2. Maximum user weight for the Bowflex® Xtreme^{2™} home gym is 300 lbs. For your safety, do not use or allow others to use the Bowflex® Xtreme^{2™} home gym if they weigh in excess of 300 lbs.
3. This machine is meant for individual consumer use only, and is not meant for use by institutions, clubs, etc.
4. Inspect your machine for any worn or loose components prior to use.
5. Do not wear any loose or dangling clothing or jewelry while using the Bowflex® Xtreme^{2™} home gym. Stand clear of moving components.
6. Always read and follow the Warning and Safety labels attached to your Bowflex®. Do not remove these labels. If you need replacement labels, please call a Nautilus Representative at (800) 269-3539.
7. Never use dumbbells or other weights to incrementally increase the weight resistance. Use only the Power Rods® that came with your Bowflex® Xtreme^{2™} home gym.
8. Set up and use your Bowflex® Sport™ home gym on a hard, level surface.

Define Your Goals

Your body will do what you train it to do. That's why it's important to define your goals and focus them. Here are some fitness components that will help you define your goals and choose your fitness program.

Muscle Strength is the maximum force that you can exert against resistance at one time. Your muscle strength comes into play when you pick up a heavy bag of groceries or lift a small child. It is developed when a localized muscle is worked both positively (concentric) and negatively (eccentric) at a resistance—great enough so you can perform only five to eight repetitions of the exercise before the muscle fails. Each set of repetitions is followed by a rest interval that typically runs three times longer than the set. Later, between exercise sessions, the muscle overcompensates for the stress and usually increases in both strength and size.

Muscle Endurance is the ability to perform repeated contractions. It comes into play when you cross-country ski or work on your feet all day. Endurance training addresses the slow twitch, endurance muscle fibers, which depend on oxygen for energy. To develop muscle endurance, use low resistance and high repetitions—about 15-20 repetitions in each set, three sets to each exercise, working the muscle only to fatigue.

Muscle Power is the combination of strength and speed of the muscular contraction. This is often misinterpreted as a) being directly associated with certain skill or sport and/or b) meaning that you must move fast. Load is actually a more important factor than speed when attempting to improve power. When training to achieve muscular power, pick a resistance that fatigues you in the 3-5 repetition range. When performing these reps, it is more important to think of contracting the muscles faster rather than attempting to move faster. Performing sport simulation exercises usually results in a deterioration of the motor pattern or skill. The biomechanically sound method of improving power in your sport is to train for power using the correct joint movements, as described in this manual. Then practice the skill associated with your sport, learning to apply this newly achieved power.

Body Composition is the ratio of fat weight (fat) to lean weight (muscles, bones and tissue). As you age, the ratio shifts. The fat weight increases and the lean weight decreases. Training for muscle strength will generally increase muscle size and aerobic conditioning will help burn extra calories. Performing these two forms of exercise, either at different times or together, will create the greatest changes in body fat weight.

Balanced Strength and alignment are the result of equal strength developed in all parts of the body. It comes into play in your standing and sitting posture, and in your ability to perform just about any activity safely and effectively. An over-development of the back will round the shoulders; weak or stretched abdominals can cause lower back pain. You want a balance of muscle strength in front and back. In addition, you need a balance of strength between your middle, lower, and upper body.

Flexibility is the ability of a muscle or group of muscles to move the joint through a full range of motion. Flexibility comes into play when you execute an overhand serve or stretch for the top shelf in the kitchen. It is a cooperative movement of opposite muscle groups. When a muscle contracts, its opposite muscle group must relax for the action to occur. Increased flexibility means an increased range of motion, made possibly by this simultaneous contracting and relaxing. Good flexibility is important in protecting the body from injury and can be achieved through the balanced strength training programs that are included in this manual.

Cardiovascular Endurance is the ability of the heart and lungs to supply oxygen and nutrients to exercising muscles over an extended period of time. It comes into play when you jog a mile or ride a bike. It is a critical component of overall fitness and health.

Design Your Own Program

You may want to design your own personal program specifically geared to your goals and lifestyle. Designing a program is easy, as long as you follow the below guidelines.

Understand fitness and its components:

Improperly designed programs can be dangerous. Take some time to review this manual as well as other fitness guides.

Know your current fitness level: Before you start any fitness program you should consult a physician who will help you determine your current abilities.

Identify your goals: Goals are critical to choosing and designing an exercise program that fits and enhances your lifestyle, but so is strategy. It's important not to rush the process and try to accomplish too much too soon. That will lead to setbacks and discouragement. Instead, set a series of smaller achievable goals.

Select complementary exercises: Be sure to pair exercises that address compound joint movements and single joint movements. In addition, select exercises that address complimentary muscle groups.

Put first things first: During each session, first work muscle groups that need the most training.

Remember your cardiovascular component:

Any fitness program must contain a cardiovascular fitness component to be complete. So complement your resistance training with aerobic exercise such as walking, running, or bicycling.

Training variables: When designing your own program there are several variables that, when mixed properly, will equal the right fitness formula for you. In order to find out the best formula, you must experiment with several combinations of variables.

The variables are as follows:

- **Training Frequency:** The number of times you train per week. We recommend daily activity but not daily training of the same muscle group.
- **Training Intensity:** The amount of resistance used during your repetition.
- **Training Volume:** The number of repetitions and sets performed.
- **Rest intervals:** The time you rest between sets and the time you rest between workouts.

Once you've established a base of fitness, follow these basic principles:

- **Isolate muscle groups:** Focus work on specific muscle groups.
- **Progressive Loading:** The gradual systematic increase of repetitions, resistance and exercise period.

Working Out

A workout begins in your mind's eye. With concentration and visualization you can approach your workout with a positive, constructive attitude. A good pre-workout mental routine is to sit and relax, so that you can focus on what you are about to do and think about achieving your end goal.

Warming Up

We recommend that you warm up by doing light stretching and performing light exercises on the Bowflex.

Your Routine

The workout portion of your fitness routine is the series of exercises devoted to your particular goals. Remember, make sure to have fun!

Cool Down

An essential part of the exercise routine is the cool down. Gradually reduce the level of exercise intensity so that blood does not accumulate in one muscle group, but continues to circulate at a decreasing rate. Remember to gradually move yourself into a relaxed state.

Breathing

The most important part of breathing during exercise is, quite simply, that you do it. Breathing in or out during the actual performance is not dependent upon the direction of air flow relative to exertion. It is, in fact, a mechanical process that changes the position of your spine as your rib cage moves. Here are some tips for breathing:

- 1) Be cautious when you are concentrating or exerting effort. This is when you will probably hold your breath. **DO NOT** hold your breath. Do not exaggerate breathing. Depth of inhalation and exhalation should be natural for the situation.
- 2) Allow breathing to occur naturally, don't force it.

The Workouts

20 MINUTE BETTER BODY WORKOUT

FREQUENCY: 3 DAYS PER WEEK (M-W-F) TIME: ABOUT 20 MINUTES

Start by performing one set of each exercise. Warm up with a light resistance that you can perform easily for 5–10 reps without fatiguing. Focus on practicing and learning your technique before increasing the resistance. Then move to a more challenging resistance that you can perform no less than 10 reps and no more than 15 reps without your form deteriorating. As you become stronger, you can advance to two sets for each exercise. Complete all sets of each exercise before moving on to the next one. Rest 30 to 45 seconds between sets. Move slowly on each rep. Use a pace that would allow you to stop the movement instantly at any point in the rep. Count three seconds up and three seconds down and work to fatigue during each set.

Body Part	Exercise	Sets	Reps
Chest	Bench Press	1-2	10-15
Back	Seated Lat Rows	1-2	10-15
Shoulders	Crossover Rear Delt Rows	1-2	10-15
Arms	Biceps Curl	1-2	10-15
	Triceps Pushdown	1-2	10-15
Legs	Leg Extension	1-2	10-15
	Leg Curl	1-2	10-15
Trunk	Standing Low Back Extension	1-2	10-15
	Seated Abdominal Crunch	1-2	10-15

ADVANCED GENERAL CONDITIONING

FREQUENCY: 4 DAYS PER WEEK (M-T-Th-F) TIME: ABOUT 35-45 MINUTES

When you are proficient in performing the exercise techniques of the above routine and are no longer realizing results, or have become just plain bored, it is time to change your program. You can increase your training with this “split system” routine that works opposing muscle groups on different days. To do this, you’ll increase your resistance when you can perform 12 reps perfectly, and you’ll increase your volume by performing more sets and more exercises. Move slowly on each rep. Use a pace that would allow you to stop the movement instantly at any point in the rep. Count three seconds up and three seconds down and work to fatigue during each set.

Day 1 & 3

Body Part	Exercise	Sets	Reps
Chest	Bench Press	1-3	10-12
Shoulders	Seated Shoulder Press	1-3	10-12
Arms	Triceps Pushdown	1-3	10-12
	Biceps Curl	1-3	10-12
Legs	Leg Extension	1-3	10-12
	Leg Curl	1-3	10-12

Day 2 & 4

Body Part	Exercise	Sets	Reps
Back	Seated Lat Rows	1-3	10-12
	Seated Lat Pulldowns	1-3	10-12
Shoulders	Crossover Rear Delt Row	1-3	10-12
Arms	Biceps Curl	1-3	10-12
	Reverse Curl	1-3	10-12
Trunk	Standing Low Back Extension	1-3	10-12
	Seated Abdominal Crunch	1-3	10-12

20 MINUTE UPPER/LOWER BODY

FREQUENCY: 4 DAYS PER WEEK (M-T-Th-F) TIME: ABOUT 20 MINUTES

This program provides you with a quick and effective workout that combines muscle conditioning with some cardiovascular benefits. Do this routine when you are limited in time or just want a variation to your normal routine. Perform this program training 2 days, resting 1 to 2. Perform all exercises to near failure, stopping at the point that your technique starts to deteriorate. Rest only 20-30 seconds between sets. As you get stronger, increase the number of sets you perform. Move slowly on each rep. Use a pace that would allow you to stop the movement instantly at any point in the rep. Count three seconds up and three seconds down.

DAY 1 & 3

Body Part	Exercise	Sets	Reps
Chest	Bench Press	1-3	12-15
Back	Seated Lat Rows	1-3	12-15
Shoulders	Crossover Rear Delt Rows	1-3	12-15
Arms	Biceps Curl	1-3	12-15
	Triceps Extension	1-3	12-15

DAY 2 & 4

Body Part	Exercise	Sets	Reps
Legs	Leg Extension	1-3	12-15
	Leg Curl	1-3	12-15
	Standing Hip Extension	1-3	12-15
	Standing Hip Abduction	1-3	12-15
Trunk	Standing Low Back Extension	1-3	10-12
	Seated Abdominal Crunch	1-3	10-12

BODY BUILDING

FREQUENCY: 3 DAYS ON, 1 DAY OFF

TIME: ABOUT 45–60 MINUTES

Body building requires focused concentration and dedication to training, as well as proper eating habits. Train each muscle group to failure before moving on to the next exercise. Do not neglect any muscle group. If needed, include an aerobic activity to increase your caloric expenditure and help to reduce your body fat levels to achieve a defined muscular look. Rest 30–60 seconds between each set and exercise. Focus on proper form. Tighten the muscle before you move, squeeze the muscle as you move, cramp the muscle at the point of full contraction, and resist the movement as you lower the weight. Move slowly on each rep. Use a pace that would allow you to stop the movement instantly at any point in the rep. Count three seconds up and three seconds down and work to fatigue during each set.

DAY 1

Body Part	Exercise	Sets	Reps
Chest	Bench Press	2-4	8-12
	Chest Fly	2-4	8-12
Shoulders	Seated Shoulder Press	2-4	8-12
	Crossover Rear Delt Row	2-4	8-12
	Lateral Shoulder Raise	2-4	8-12
	Shoulder Shrug	2-4	8-12

DAY 2

Body Part	Exercise	Sets	Reps
Back	Seated Lat Row	2-4	8-12
	Seated Lat Pulldowns	2-4	8-12
Arms	Biceps Curl	2-4	8-12
	Reverse Curl	2-4	8-12
	Triceps Pushdown	2-4	8-12
	Triceps Extension	2-4	8-12

DAY 3

Body Part	Exercise	Sets	Reps
Legs	Squat	2-4	8-12
	Leg Extension	2-4	8-12
	Standing Hip Extension	2-4	8-12
	Leg Curl	2-4	12-15
Trunk	Standing Low Back Extension	2-4	8-12
	Seated Abdominal Crunch	2-4	8-12
	Seated Oblique Abdominal Crunch	2-4	8-12

CIRCUIT TRAINING—ANAEROBIC/CARDIOVASCULAR

FREQUENCY: 2-3 TIMES PER WEEK TIME: ABOUT 20–45 MINUTES

Circuit training is a great way to achieve the benefits of strength training and cardiovascular training in one quick, challenging routine. The idea is to move quickly from exercise to exercise, taking only as much rest between sets as it takes to set up the next exercise (less than 20 seconds). One circuit equals one set of each exercise. Initially, start with completing one round of Circuit 1. Then add an additional round of the same circuit. Once you reach three rounds of Circuit 1, add one round of Circuit 2. Add additional rounds of Circuit 2 as your fitness level increases. Repeat process with Circuit 3. Do not let your heart rate exceed 220 minus your resting heart rate. Perform each rep of each exercise slowly and with perfect technique. Count three seconds up and three seconds down.

Circuit 1	Body Part	Exercise	Reps
	Chest	Bench Press	8–12
	Legs	Squat	8–12
	Back	Seated Lat Row	8–12
	Legs	Leg Curl	8–12
	Trunk	Seated Abdominal Crunch	8–12

Circuit 2	Body Part	Exercise	Reps
	Shoulders	Seated Shoulder Press	8–12
	Legs	Leg Extensions	8–12
	Back	Seated Lat Pulldowns	8–12
	Trunk	Standing Low Back Extension	8–12
	Arms	Biceps Curl	8–12

Circuit 3	Body Part	Exercise	Reps
	Shoulders	Crossover Rear Delt Rows	8–12
	Arms	Triceps Pushdown	8–12
	Legs	Leg Curl	8–12
	Trunk	Seated Oblique Crunch	8–12

TRUE AEROBIC CIRCUIT TRAINING

FREQUENCY: 2-3 TIMES PER WEEK TIME: ABOUT 20-60 MINUTES

Circuit training is a great way to achieve the benefits of strength training and cardiovascular training in one quick, challenging routine. By returning to an aerobic exercise between each set you are increasing your aerobic capacity, endurance and burning fat as energy. The idea is to move quickly from exercise to exercise, taking only as much rest between sets as it takes to set up the next exercise (less than 20 seconds). One circuit equals one set of each exercise. Initially, start with completing one round of Circuit 1. Then add an additional round of the same circuit. Once you reach three rounds of Circuit 1, add one round of Circuit 2. Add additional rounds of Circuit 2 as your fitness level increases. Do not let your heart rate exceed 220 minus your resting heart rate. Perform each rep of each exercise slowly and with perfect technique. Count three seconds up and three seconds down.

Any type of aerobic exercise can be used for this routine. Some examples are: jumping jacks, jogging in place, or stair climbing.

Circuit 1

Body Part	Exercise	Reps
Chest	Bench Press	8-12
Aerobic Exercise	30-60 Seconds	
Legs	Squat	8-12
Aerobic Exercise	30-60 Seconds	
Back	Seated Lat Rows	8-12
Aerobic Exercise	30-60 Seconds	
Legs	Leg Curl	8-12
Aerobic Exercise	30-60 Seconds	
Trunk	Seated Abdominal Crunch	8-12
Aerobic Exercise	30-60 Seconds	

Circuit 2

Body Part	Exercise	Reps
Shoulders	Seated Shoulder Press	8-12
Aerobic Exercise	30-60 Seconds	
Legs	Leg Extension	8-12
Aerobic Exercise	30-60 Seconds	
Back	Seated Lat Pulldowns	8-12
Aerobic Exercise	30-60 Seconds	
Trunk	Standing Low Back Extension	8-12
Aerobic Exercise	30-60 Seconds	
Arms	Biceps Curl	8-12

STRENGTH TRAINING

FREQUENCY: 3 DAYS PER WEEK (M-W-F) TIME: ABOUT 45–60 MINUTES

This program is designed to emphasize overall strength development. This is an advanced routine to be used only after you have progressed from the advanced general conditioning routine and only after you have perfected your exercise techniques. Work each set to near exhaustion. If you can perform more than 5 to 8 reps, you should increase your resistance 5 lbs and decrease your reps to 5. Rest 60–120 seconds between each set and exercise. Focus on proper form. Tighten the muscle before you move, squeeze the muscle as you move, cramp the muscle at the point of full contraction, and resist the movement as you lower the weight. Move slowly on each rep. Use a pace that would allow you to stop the movement instantly at any point in the rep. Count two seconds up and four seconds down and work to fatigue during each set.

Day 1

Body Part	Exercise	Sets	Reps
Chest	Bench Press	2-4	5-8
	Chest Fly	2-4	5-8
Shoulders	Seated Shoulder Press	2-4	5-8
	Crossover Rear Delt Rows	2-4	5-8
	Shoulder Shrug	2-4	5-8

Day 2

Body Part	Exercise	Sets	Reps
Back	Seated Lat Row	2-4	5-8
	Seated Lat Pulldowns	2-4	5-8
Arms	Biceps Curl	2-4	5-8
	Reverse Curl	2-4	5-8
	Triceps Pushdown	2-4	5-8
	Triceps Extension	2-4	5-8

Day 3

Body Part	Exercise	Sets	Reps
Legs	Squat	2-4	5-8
	Leg Extension	2-4	5-8
	Leg Curl	2-4	5-8
	Standing Hip Extension	2-4	5-8
Trunk	Standing Low Back Extension	2-4	5-8
	Seated Abdominal Crunch	2-4	5-8

Bench Press—Shoulder Horizontal Adduction (and elbow extension)

Muscles worked:

Pectoralis Major; Deltoids; Triceps

Position:

Seated—facing outward

Accessory:

Hand Grips

Pulleys:

Center Cross Bar—Wide Pulleys

Leg Extension:

Removed

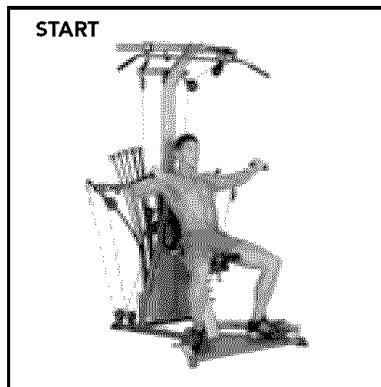
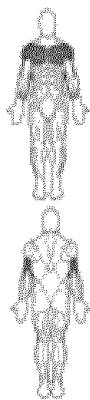

START

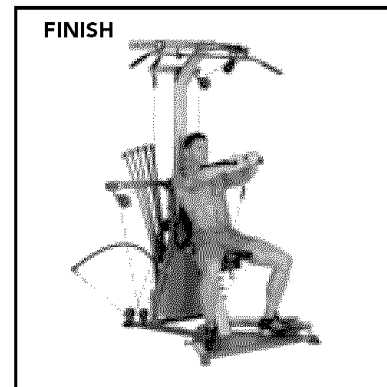

FINISH

Success Tips

- Maintain a 90° angle between upper arms and torso throughout motion.
- Keep chest muscles tightened. Limit and control your range of motion.
- Keep knees bent, feet on Platform, head back against Seat Back Pad.
- Keep elbows in front of shoulders.
- Keep shoulder blades pinched together and maintain good spinal alignment.

START

- Grasp Hand Grips in both hands.
- Bend your elbows until hands are at chest level. Rotate upper arms away from torso, elbows out, palms forward.
- Line up arms with cables keeping your wrists straight.
- Raise chest, pinch shoulder blades together, and maintain a slight, comfortable arch in your lower back.

ACTION

- Slowly press your hands forward, straightening your arms while moving your hands together. Do not lock elbows.
- Return to start position, keeping your wrists at shoulder width and in line with the cables.

Chest Fly—Shoulder Horizontal Adduction (elbow stabilized)

Muscles worked:

Pectoralis Major; Anterior Deltoid

Position:

Seated—facing outward

Accessory:

Hand Grips

Pulleys:

Center Cross Bar—Wide Pulleys

Leg Extension:

Removed

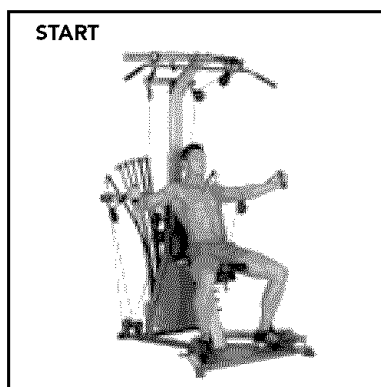

START

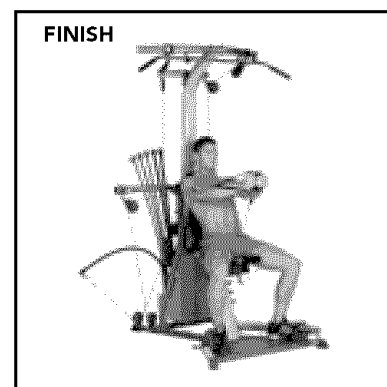

FINISH

Success Tips

- Maintain a 60-90° angle between upper arms and torso during exercise.
- Keep chest muscles tightened. Limit and control your range of motion.
- Keep knees bent, feet on Platform, head back against Seat Back Pad.
- To improve your pectoralis involvement, keep your shoulder blades pinched together throughout upward and downward movements.

START

- Grasp Hand Grips in both hands.
- Open your arms into a wide, elbow bent position, keeping elbows and forearms below chest level, palms forward.
- Raise chest, pinch shoulder blades together, and maintain a slight, comfortable arch in your lower back.

ACTION

- Slowly press your arms forward and upward, straightening arms and moving your hands together.
- Rotate your wrists and forearms upward, making sure that your arms are directly “in line” with the cables.
- Slowly return to start position.

Decline Bench Press—Shoulder Horizontal Adduction (and elbow extension)

Muscles worked:

Pectoralis Major; Deltoids; Triceps

Position:

Seated—facing outward

Accessory:

Hand Grips

Pulleys:

Center Cross Bar—Wide Position

Leg Extension:

Removed

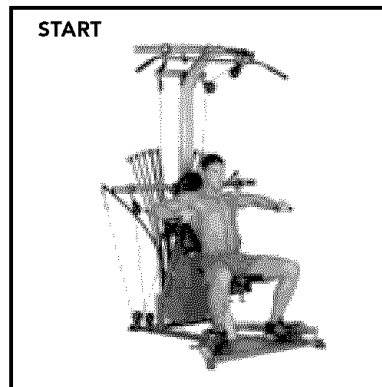
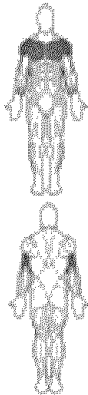

START



FINISH

Success Tips

- Maintain a 90° angle between your upper arms and torso at the start of the motion, and slightly less than 90° at the finish.
- Keep knees bent, feet on Platform, head back against Seat Back Pad.
- Do not let your elbows travel behind your shoulders.
- Keep shoulder blades pinched together and maintain good spinal alignment.

START

- Grasp Hand Grips in both hands.
- Cables travel beneath arms, forearms aligned with cables.
- Bend your elbows, keeping your forearms at least 10° lower than when in the “standard” Bench Press start position.
- Raise chest, pinch shoulder blades together, and maintain a comfortable arch in lower back.

ACTION

- Slowly straighten your elbows, keeping upper arms at a 90° angle from your torso. Forearms should be 5-6” lower than when in the standard Bench Press position. Do not lock your elbows.
- Slowly return to the start position, keeping your wrists steady and your movements slow and controlled.

Incline Bench Press—Shoulder Horizontal Adduction (and elbow extension)

Muscles worked:

Pectoralis Major; Deltoids; Triceps

Position:

Seated—facing outward

Accessory:

Hand Grips

Pulleys:

Center Cross Bar—Wide Position

Leg Extension:

Removed

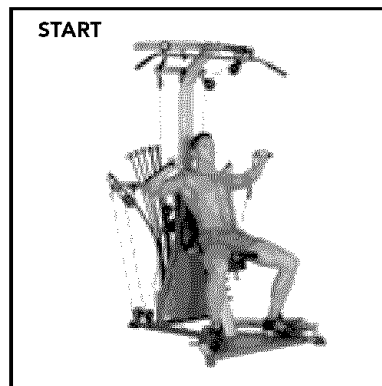
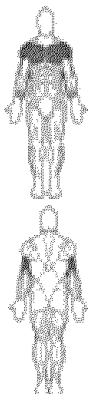

START

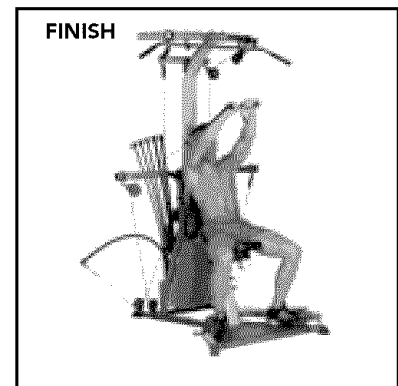

FINISH

Success Tips

- Maintain a 90° angle between your upper arms and torso at the start of the motion, and slightly less than 90° at the finish.
- Keep knees bent, feet on Platform, head back against Seat Back Pad.
- Do not let your elbows travel behind your shoulders.
- Keep shoulder blades pinched together and maintain good spinal alignment.

START

- Grasp Hand Grips in both hands.
- Cables travel over arms, forearms aligned with cables.
- Bend your elbows, keeping your forearms at least 10° higher than when in the “standard” Bench Press start position.
- Raise chest, pinch shoulder blades together, and maintain a comfortable arch in lower back.

ACTION

- Slowly straighten your elbows, keeping upper arms at a 90° angle from your torso. Forearms should be 5-6” higher than when in the standard Bench Press position. Do not lock your elbows.
- Slowly return to the start position, keeping your wrists steady and your movements slow and controlled.

Decline Chest Fly—Shoulder Horizontal Adduction (elbow stabilized)

Muscles worked:

Pectoralis Major; Anterior Deltoid

Position:

Seated—facing outward

Accessory:

Hand Grips

Pulleys:

Center Cross Bar—Wide Position

Leg Extension:

Removed

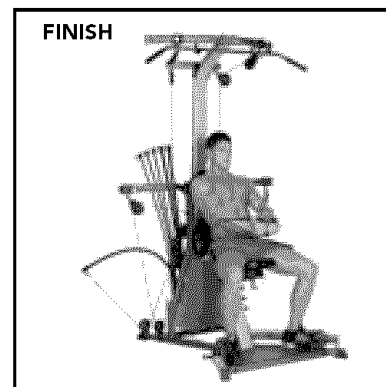
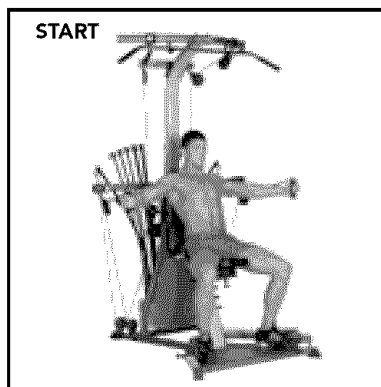
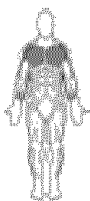

Success Tips

- Maintain a 60-90° angle between upper arms and torso during exercise.
- Keep chest muscles tightened. Limit and control your range of motion.
- Keep knees bent, feet on Platform, head back against Seat Back Pad.
- To improve your pectoralis involvement, pinch your shoulder blades together throughout movement.

START

- Grasp Hand Grips in both hands.
- Open your arms into a wide, “embrace” position, elbows slightly bent. Press your forearms downward. At full extension, hands should be level with your hips, palms facing forward.
- Do not lock your elbows.
- Raise chest, pinch shoulder blades together, and maintain a slight, comfortable arch in your lower back.

ACTION

- Slowly press your arms forward and downward, straightening arms and moving your hands together. Hands should be 5-6” lower than standard Chest Fly Finish position.
- Rotate your wrists and forearms upward.
- Return to start position, slowly bringing your arms in front of you, just below chest level.

Incline Chest Fly—Shoulder Horizontal Adduction (elbow stabilized)

Muscles worked:

Pectoralis Major; Anterior Deltoid

Position:

Seated—facing outward

Accessory:

Hand Grips

Pulleys:

Center Cross Bar—Wide Pulleys

Leg Extension:

Removed

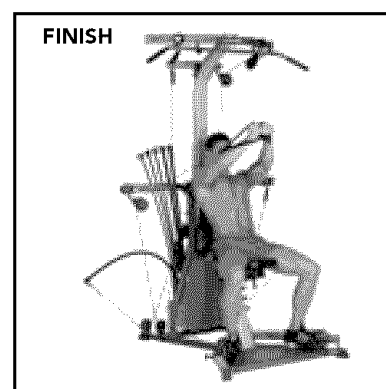
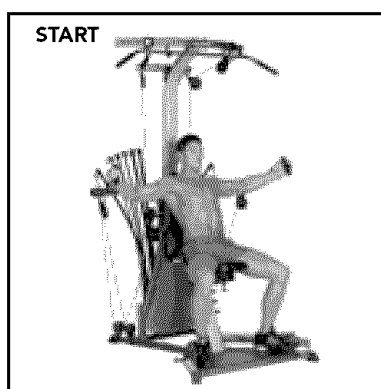
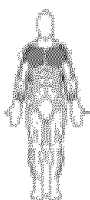

Success Tips

- Maintain a 60-90° angle between upper arms and torso during exercise.
- Keep chest muscles tightened. Limit and control your range of motion.
- Keep knees bent, feet on Platform, head back against Seat Back Pad.
- To improve your pectoralis involvement, pinch your shoulder blades together throughout movement.

START

- Grasp Hand Grips in both hands.
- Press your arms forward and upward, straightening arms and moving your hands together. Hands should be 5-6” higher than the standard Chest Fly start position..
- Do not lock your elbows.
- Raise chest, pinch shoulder blades together, and maintain a slight, comfortable arch in your lower back.

ACTION

- Open your arms into a wide, “embrace” position, elbows slightly bent. Press your forearms upward. At full extension, your elbows should be level with your ears, palms facing forward.
- Rotate your wrists and forearms upward.
- Return to Start position, slowly bringing your arms in front of you, just below chest level.

Crossover Rear Delt Rows—Elbow Flexion

Muscles worked:

Anterior and Middle Deltoids

Position:

Standing—facing Power Rods®

Accessory:

Hand Grips

Pulleys:

Center Cross Bar—Narrow Pulleys

Leg Extension:

Removed

Success Tips

- Maintain a 90° angle between your upper arms and torso during motion.
- Lift your chest, keep your knees bent and feet on Standing Platform.
- To work one arm at a time, place non-working hand on Seat Back Pad to stabilize.
- Keep shoulder blades pinched together and maintain good spinal alignment.

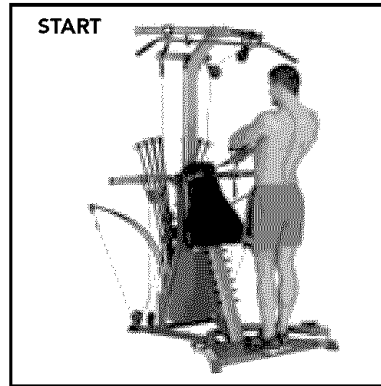

START

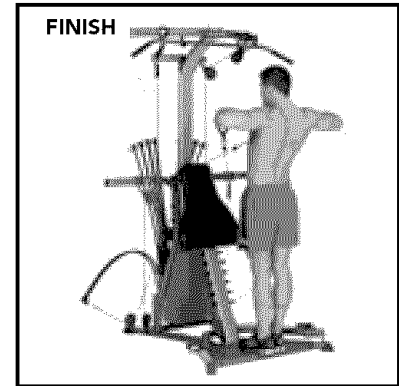

FINISH

START

- Cross your arms in front of you and grasp the Hand Grips (right Grip in left hand and vice versa), palms facing toward the floor, arms nearly straight.
- Bend slightly from hips and raise your arms until they are in front of your body at a 90° angle to your torso.

ACTION

- Allowing your arms to bend as you go, move your elbows outward and backward.
- Keep your forearms pointing in the direction of the cables.
- Slowly return to the start position. Do not relax the tension in your shoulder muscles.

Crossover High Rear Delt Rows—Elbow Flexion

Muscles worked:

Anterior and Middle Deltoids

Position:

Standing—facing Power Rods®

Accessory:

Hand Grips

Pulleys:

Front Lat Cross Bar

Leg Extension:

Removed

Success Tips

- Maintain a 90° angle between your upper arms and torso during motion.
- Keep shoulder blades pinched together, good spinal alignment and your chest lifted throughout exercise.
- Lift your chest, keep your knees bent and feet on Standing Platform.

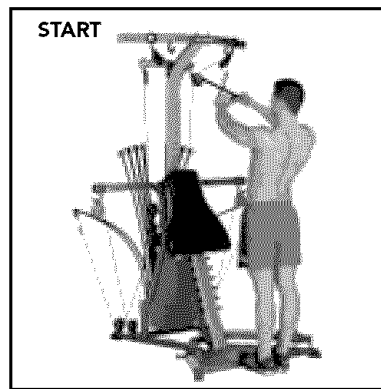

START

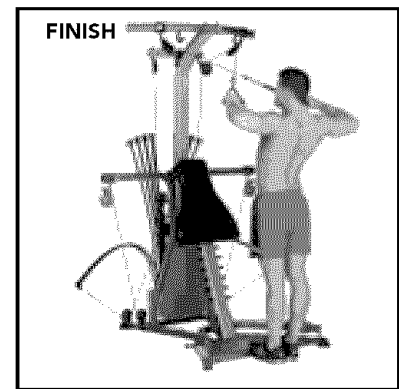

FINISH

START

- Cross your arms in front of you and grasp the Hand Grips (right Grip in left hand and vice versa), palms facing toward the floor, arms nearly straight.
- Stand up straight and then lean back slightly from hips.

ACTION

- Allowing your arms to bend as you go, move your elbows outward and backward.
- Keep your forearms pointing in the direction of the cables.
- Move until your elbows are slightly behind your shoulders.
- Slowly return to the start position. Do not relax the tension in your shoulder muscles.

Reverse Fly—Shoulder Horizontal Abduction (elbows stabilized in slight flexion)

Muscles worked:

Rear Deltoids; Middle Deltoids;
Trapezius; Rhomboids

Position:

Standing—facing Power Rods®

Accessory:

Hand Grips

Pulleys:

Center Cross Bar—Narrow Pulleys

Leg Extension:

Removed

Success Tips

- Do not lose spinal alignment—keep your chest lifted.
- Lift your chest, keep your knees bent and feet on Standing Platform.
- Keep your spine aligned and a slight arch in your lower back.
- Maintain a 90° angle between upper arms and torso throughout exercise.

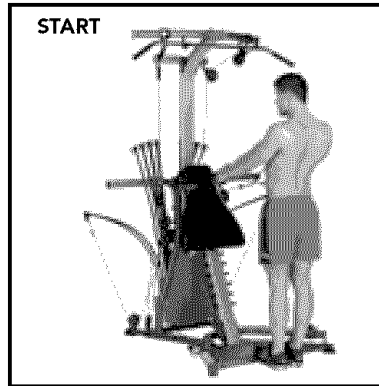
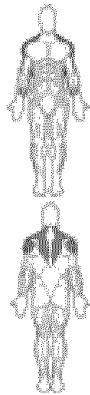

START

START

- Grasp the Hand Grips, palms facing floor, arms nearly straight.
- Stand up straight and bend slightly forward from the hips until arms/cables are in front of body at a 90° angle from torso.

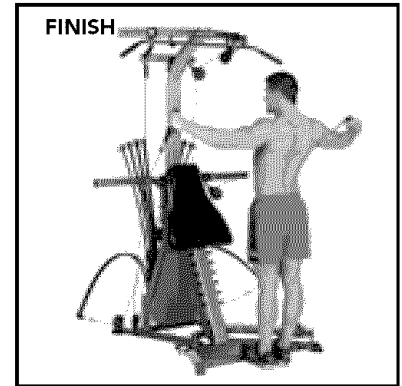

FINISH

ACTION

- Maintaining the bend in your arms, move your elbows outward and backward.
- When your elbows are slightly behind your shoulders, slowly return to the start position, keeping your rear shoulder muscles tightened throughout movement.

Crossover Reverse Fly—Shoulder Horizontal Abduction (elbows stabilized in slight flexion)

Muscles worked:

Rear Deltoids; Middle Deltoids;
Trapezius; Rhomboids

Position:

Standing—facing Power Rods®

Accessory:

Hand Grips

Pulleys:

Center Cross Bar—Narrow Pulleys

Leg Extension:

Removed

Success Tips

- Do not lose spinal alignment—keep your chest lifted.
- Lift your chest, keep your knees bent and feet on Standing Platform.
- Keep your spine aligned and a slight arch in your lower back.
- Maintain a 90° angle between upper arms and torso throughout exercise.

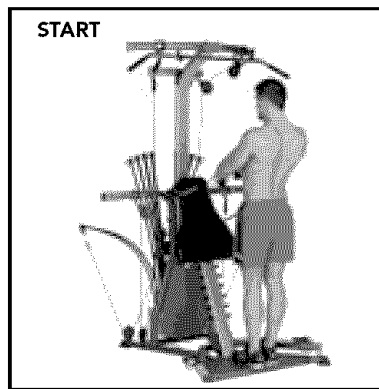
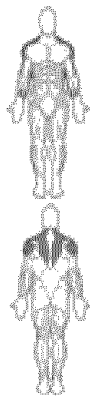

START

START

- Cross your arms in front of your body and grasp the Hand Grips, right Grip in left hand and vice versa, with your palms facing the floor and arms nearly straight.
- Stand up straight and bend slightly forward from the hips until arms/cables are in front of body at a 90° angle from torso.

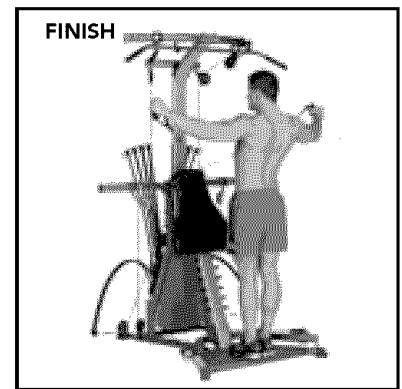

FINISH

ACTION

- Maintaining the bend in your arms, move your elbows outward and backward, crossing the cables as your arms move back.
- When your elbows are slightly behind your shoulders, slowly return to the start position, keeping your rear shoulder muscles tightened throughout movement.

Seated Shoulder Press—Shoulder Adduction (and elbow extension)

Muscles worked:

Front Deltoids; Upper Trapezius; Triceps

Position:

Seated—facing outward

Accessory:

Hand Grips

Pulleys:

Center Cross Bar—Wide Pulleys

Leg Extension:

Removed

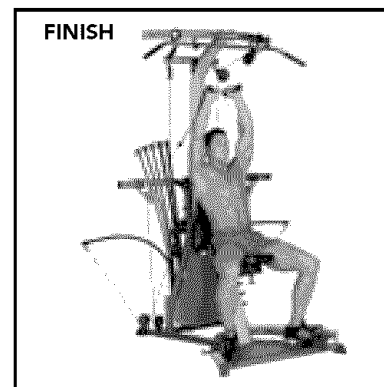
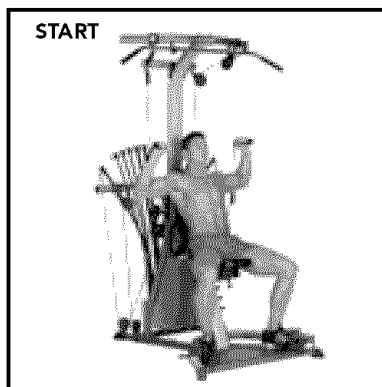
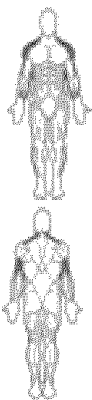

START

- Grasp Hand Grips, palms facing away from the Power Rods[®].
- Raise the Hand Grips to shoulder level, keeping your palms facing forward.

ACTION

- Straighten your arms slowly over your head, focusing on moving your elbows up and inward toward your ears.
- Slowly return to the start position, keeping tension in your front shoulder muscles.

Success Tips

- Lift your chest, keep your knees bent and feet on Standing Platform.
- Do not increase the arch in your lower back as you raise your arms, but keep your spine steady and tight.
- Keep abdominals tight and maintain good spinal alignment.

Front Shoulder Raise—Shoulder Flexion (elbow stabilized)

Muscles worked:

Front and Middle Deltoids

Position:

Standing—facing outward

Accessory:

Hand Grips

Pulleys:

Squat Pulley Frame—Wide Pulleys

Leg Extension:

Removed

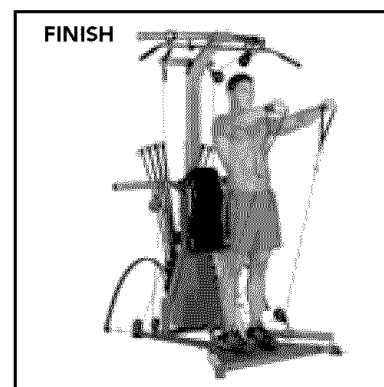
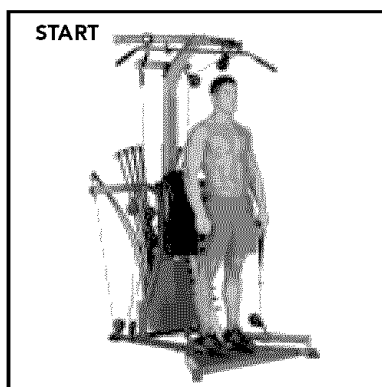
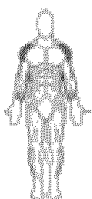

START

- Grasp the Hand Grips, palms facing back toward the Power Rods[®], arms straight at your sides.

ACTION

- Keeping your arms straight, move them forward, leading with your forearms, until arms are extended in front of you at shoulder height.
- Arms may be moved alternately or together.
- Slowly return to the start position with your upper arms next to your torso.

Success Tips

- Keep abdominals tight and maintain good spinal alignment.
- Lift your chest, keep your knees bent and feet on Standing Platform.
- Do not increase the arch in your lower back as you raise your arms. You may wish to lean your lower back against the Seat Back Pad.

Shoulder Extension—(elbows stabilized)

Muscles worked:

Latissimus Dorsi; Teres Major; Rear Deltoid; Middle Trapezius; Rhomboids; Triceps



Position:

Standing, facing Power Rods®

Accessory:

Hand Grips

Pulleys:

Center Cross Bar—Narrow Pulleys

Leg Extension:

Removed

Success Tips

- Keep your chest lifted, knees bent and feet braced against the Standing Platform.
- Keep your lats tightened throughout the motion.
- Keep abdominals tight and maintain good spinal alignment.
- Release your shoulder blades at the end of each rep and initiate new rep by retracting your shoulder blades.

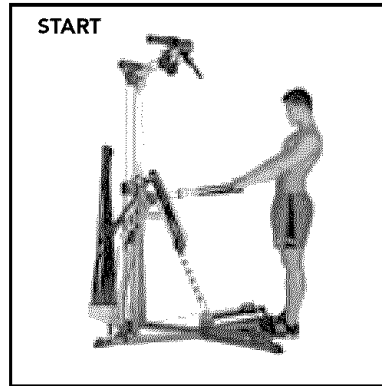

START

- Grasp the Hand Grips, palms facing down, arms straight and at an approximately 45° angle from your torso.
- Tighten your trunk muscles to stabilize your spine while maintaining a slight arch in the lower back.

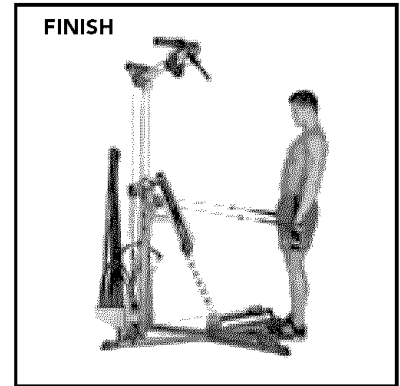

ACTION

- Initiate movement by pinching shoulder blades together.
- Continue movement by moving your hands in an arc downward, along your sides, until hands are level with hips.
- With controlled movement, slowly return to the start position.

Shoulder Shrug—Scapular Elevation

Muscles worked:

Upper Trapezius

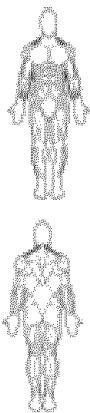

Position:

Standing, facing Power Rods®

Accessory:

Hand Grips

Pulleys:

Squat Pulley Frame—Standard Pulleys

Leg Extension:

Removed

Success Tips

- Keep abdominals tight and maintain good spinal alignment.
- Do not bend your neck or slouch during this exercise.
- Raise shoulders evenly.
- For variation, try this exercise bent forward slightly from the hips.

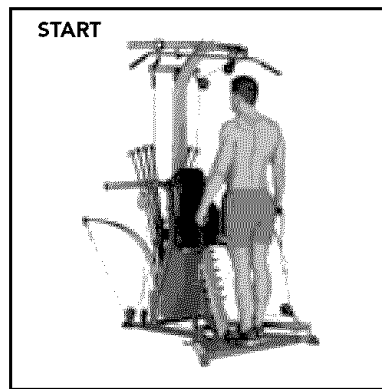

START

- Reach down and grasp the Hand Grips, palms facing each other.
- Let your arms hang at your sides.

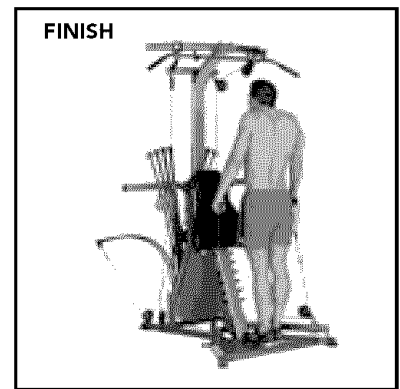

ACTION

- Slowly raise your shoulders towards the back of your head, keeping your neck and head still.
- Slowly reverse the motion back to the start position, keeping your upper trapezius muscles tight throughout the motion.

Scapular Protraction—(elbows stabilized)

Muscles worked:

Serratus Anterioris

Position:

Seated—facing outward

Accessory:

Hand Grips

Pulleys:

Center Cross Bar—Narrow Pulleys

Leg Extension:

Removed

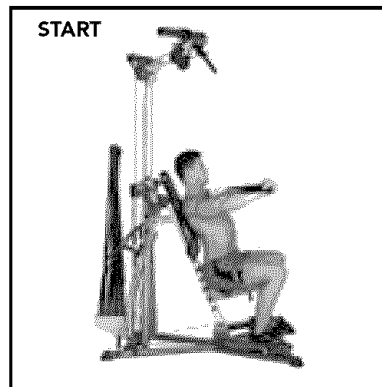

START

- Reach behind your body, grasp the Hand Grips and straighten your arms in front of you at a 90° angle from torso.
- Keep your arms in line with the cables, palms facing down and wrists straight.

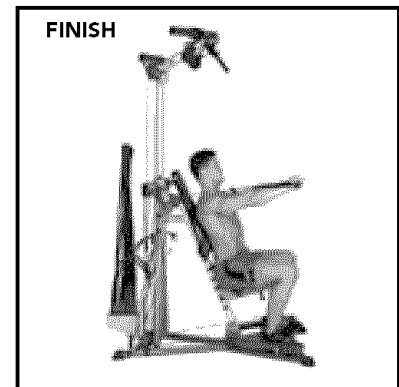

ACTION

- Keeping your arms straight and in line with the cables, slowly move your shoulder blades forward, away from the Seat Back Pad. Slowly bring your hands together using only your shoulder muscles.
- Slowly return to the start position, keeping tension in your shoulder blades.
- Movement is very subtle and occurs only in shoulder blades.

Success Tips

- Lift your chest, keep your knees bent and feet on Standing Platform.
- You may wish to lean your head against the Seat Back Pad.
- Keep your spine aligned and a slight arch in your lower back.
- Maintain a 90° angle between upper arms and torso throughout exercise.
- Do not slouch forward or use your arm muscles to assist this motion. Keep this motion only in the shoulder blades.

Scapular Depression

Muscles worked:

Lower Trapezius

Position:

Seated—facing outward

Accessory:

Hand Grips

Pulleys:

Front Lat Cross Bar—Wide Pulleys

Leg Extension:

Removed

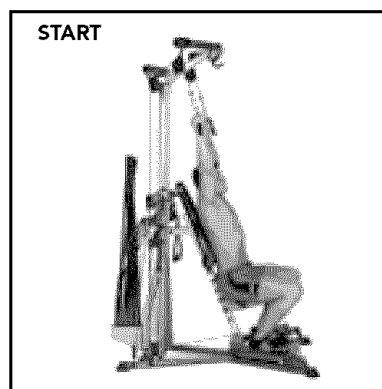

START

- Grasp the Hand Grips and raise your arms above your head, palms facing outward, arms nearly straight.
- Tighten your trunk muscles to stabilize your spine while maintaining a slight arch in your lower back.

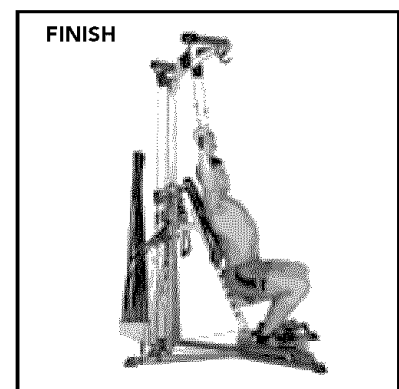

ACTION

- Keeping your arms straight, slide your shoulder blades downward, toward your hips.
- When your shoulder blades have fully depressed, slowly return to the start position.
- Movement is very subtle and occurs only in shoulder blades.

Success Tips

- Do not lose spinal alignment—keep your chest lifted and head against the Seat Back Pad.
- Lift your chest, keep your knees bent and feet on Standing Platform.

Lateral Shoulder Raise—Shoulder Abduction (elbows stabilized)

Muscles worked:

Middle Deltoids; Supraspinatus;
Upper Trapezius

Position:

Standing—facing outward

Accessory:

Hand Grips

Pulleys:

Squat Pulley Frame—Standard Pulleys

Leg Extension:

Removed

Success Tips

- You may need to use the Squat Straps for this exercise.
- Elevate your shoulders slightly toward the back of your head.
- Maintain good spinal alignment and bend forward slightly from the hip.
- Do not swing your arms upward or move your trunk during this exercise.
- Lift your chest, keep your knees bent and feet on Standing Platform.

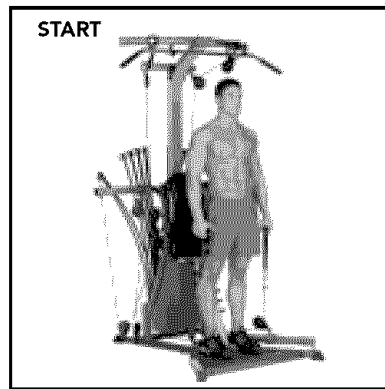

START

START

- Grasp the Hand Grips, palms facing each other.
- Let your arms hang at your sides, directly in line with the cables.
- Keep your chest lifted, and a slight arch in your lower back.

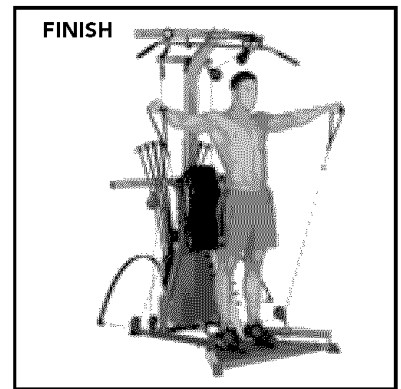

FINISH

ACTION

- Raise your arms directly out to the sides, nearly to shoulder level.
- Keep the side of your arm/elbow facing out and up throughout the movement.
- With controlled movement, slowly return to the start position.

Seated Forearm Lateral Shoulder Raise—Elbows stabilized

Muscles worked:

Middle Deltoids; Upper Trapezius;
Supraspinatus

Position:

Seated—facing outward

Accessory:

Hand Grips

Pulleys:

Squat Pulley Frame—Narrow Pulleys

Leg Extension:

Removed

Success Tips

- Raise your chest and keep your shoulder blades pinched together.
- Elevate your shoulders slightly toward the back of your head.
- Maintain good spinal alignment and bend forward slightly from the hip.
- Do not swing your arms upward or move your trunk during this exercise.
- Lift your chest, keep your knees bent and feet on Standing Platform.

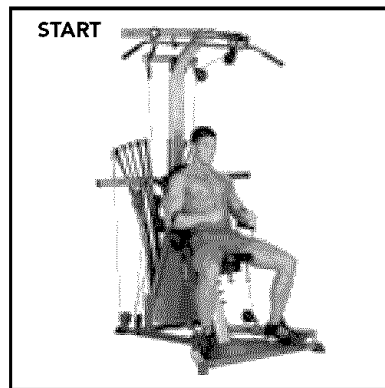

START

START

- Open the Hand Grip webbing and slide the Grips over your forearms until they are cradled in your elbows.
- Let your upper arms hang directly in line with the cables. Bend your elbows 90°.
- Sit up straight and bend slightly forward from the hips until arms/cables are in front of body at a 90° angle from torso.

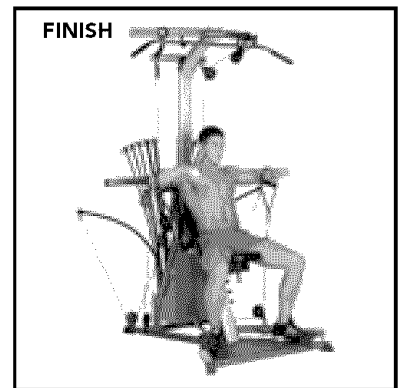

FINISH

ACTION

- Raise your arms directly out to the sides, nearly to shoulder level.
- Keep the side of your forearms/elbows facing out and up throughout the movement.
- Slowly bring your arms back to the start position without relaxing.

Shoulder Rotator Cuff—Internal Rotation

Muscles worked:

Subscapularis

Position:

Standing—facing left or right

Accessory:

Hand Grips

Pulleys:

Center Cross Bar—Wide Pulleys

Leg Extension:

Removed

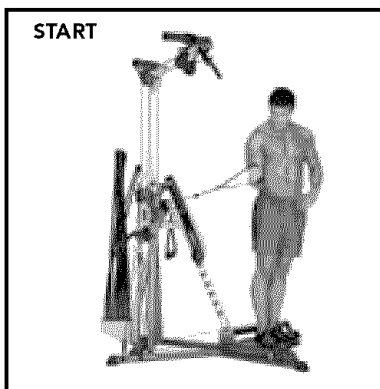

START

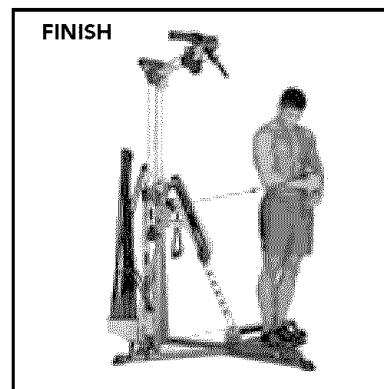

FINISH

START

- Grasp the Hand Grip nearest you in the hand closest to the Power Rods[®], and draw your upper arm into your torso. Keep your elbow bent and your forearm at a 90° angle from your torso.
- Give yourself enough distance to eliminate slack in the cable.
- Use a light resistance.—this is not a powerful movement.

ACTION

- Rotate your forearm toward your abdomen, keeping your elbow at your side throughout motion.
- Slowly return to the start position, maintaining slow, controlled motion.

Success Tips

- Lift your chest, keep your knees bent and feet on Standing Platform.
- Keep your spine aligned and a slight arch in your lower back.
- Maintain a 90° angle between forearms and torso throughout exercise.
- Do not rotate the spine to get additional range of motion.

Shoulder Rotator Cuff—External Rotation

Muscles worked:

Infraspinatus; Teres Minor

Position:

Standing—facing left or right

Accessory:

Hand Grips

Pulleys:

Center Cross Bar—Wide Pulleys

Leg Extension:

Removed

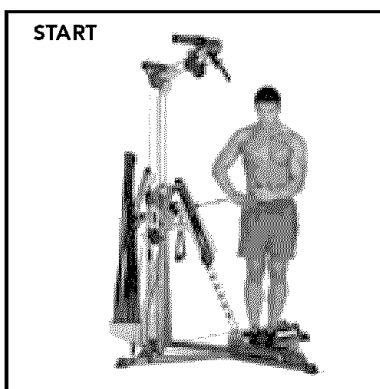

START

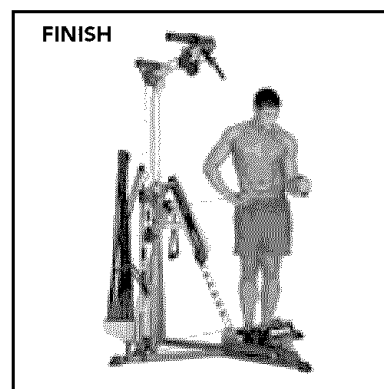

FINISH

START

- Grasp the Hand Grip nearest you in the hand farthest from the Power Rods[®], and draw your upper arm into your torso. Keep your elbow bent and your forearm at a 90° angle from your torso.
- Give yourself enough distance to eliminate slack in the cable.
- Use a light resistance.—this is not a powerful movement.

ACTION

- Rotate your forearm away from your abdomen, keeping your elbow at your side throughout motion.
- Slowly return to the start position, maintaining slow, controlled motion.

Success Tips

- Lift your chest, keep your knees bent and feet on Standing Platform.
- Keep your spine aligned and a slight arch in your lower back.
- Maintain a 90° angle between forearms and torso throughout exercise.
- Do not rotate the spine to get additional range of motion.

Crossover Seated Rear Delt Rows—Elbow Flexion

Muscles worked:

Anterior and Middle Deltoids

Position:

Seated on the floor—facing machine

Accessory:

Hand Grips

Pulleys:

Squat Pulley Frame

Leg Extension:

Removed

Success Tips

- Maintain a 90° angle between your upper arms and torso during motion.
- Keep knees bent and feet braced against the Standing Platform.
- Do not bend your torso forward.
- Keep shoulder blades pinched together and maintain good spinal alignment.

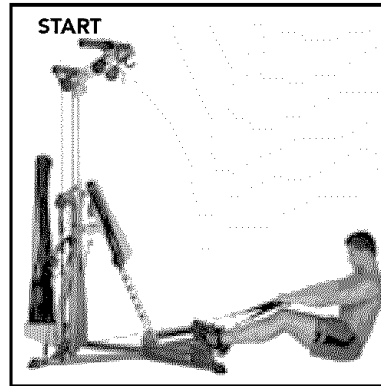

START

- Cross your arms in front of you and grasp the Hand Grips (right Grip in left hand and vice versa), palms facing toward the floor.
- Brace your heels against the end of the Standing Platform.
- Lean back slightly and straighten your arms.
- Raise your arms until they are in front of your body at approximately a 90° angle to your torso.

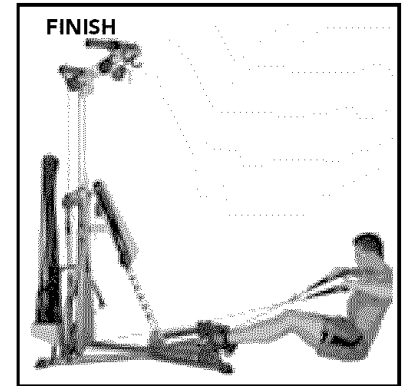

ACTION

- Allowing your arms to bend as you go, move your elbows outward and backward until elbows are parallel with your shoulders.
- Keep your forearms pointing in the direction of the cables.
- Slowly return to the start position. Do not relax the tension in your shoulder muscles.

Scapular Retraction

Muscles worked:

Middle Trapezius; Rhomboids

Position:

Seated on the floor—facing machine

Accessory:

Hand Grips

Pulleys:

Squat Pulley Frame

Leg Extension:

Removed

Success Tips

- Do not lose spinal alignment—keep your chest lifted.
- Keep knees bent and feet braced against the Standing Platform.
- Do not bend your torso forward.
- Do not use your arm muscles for this movement.

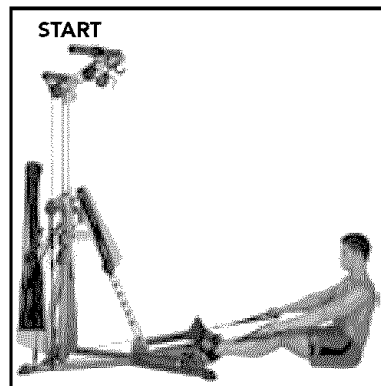

START

- Grasp the Hand Grips, palms facing each other.
- Brace your heels against the end of the Standing Platform.

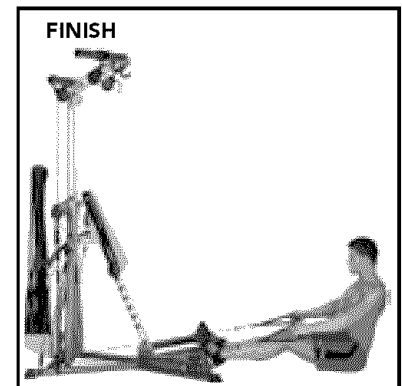

ACTION

- Keeping your arms straight, slowly pinch your shoulder blades together.
- When shoulder blades are fully retracted, slowly return to the start position.

Good Morning

Muscles worked:

Latissimus Dorsi; Teres Major;
Rear Deltoids

Position:

Standing—facing outward

Accessory:

Squat Bar

Pulleys:

Squat Pulley Frame

Leg Extension:

Removed

Success Tips

- Keep your chest lifted, spine aligned, abs tight and your back flat with no arch.
- Lift with your legs, not lower back or arms.
- Use a light resistance for this movement.
- Lift your head, keep your knees bent and feet on Standing Platform.

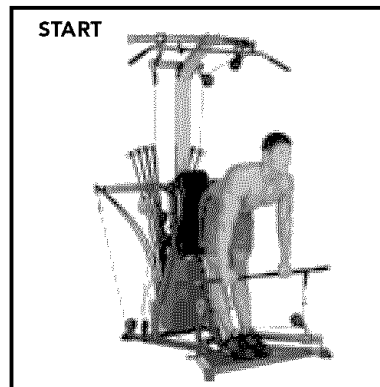

START

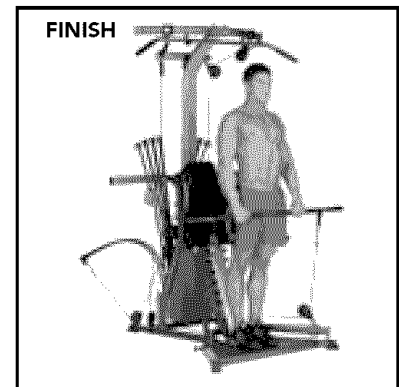

FINISH

START

- Grasp the Squat Bar with your palms facing downward.
- Keep your legs bent slightly.
- Bend over, approximately 90° from your hips (not your waist)

ACTION

- Initiate the movement by pushing your hips forward.
- Slowly move your trunk until you are in the standing position. Back should be tightened when reaching upright position
- Slowly return to the start position without relaxing tension in your legs.

Standing Low Back Extension—(with hip extension)

Muscles worked:

Lower Trapezius; Erector Spinae;
Gluteus Maximus

Position:

Standing—facing outward

Accessory:

Hand Grips

Pulleys:

Squat Pulley Frame

Leg Extension:

Removed

Success Tips

- Lift your chest, keep your knees bent and feet on Standing Platform. Pinch shoulder blades together.
- Keep your spine aligned, abs tight and a slight arch in your lower back.
- Move from the hips only—do not bend from waist.

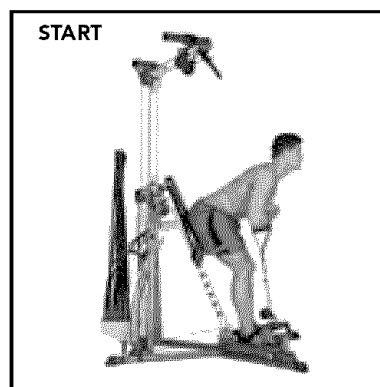

START

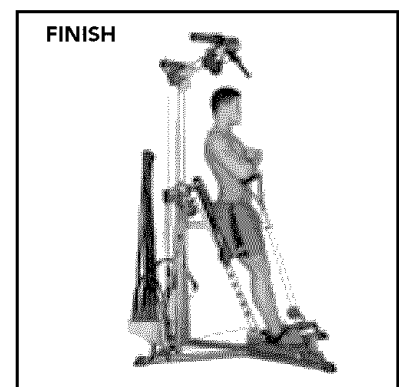

FINISH

START

- Open the webbing on the Hand Grips and slide them over your forearms, tightening near your elbows.
- Bend your knees comfortably, arms crossed in front of chest. Pull the Hand Grips tightly into your chest.
- Pinch shoulder blades together and lean forward from the hips, at least 45°, letting the tension out of the Cables.

ACTION

- Keeping your chest lifted, move your entire torso upwards into a straight standing position by pivoting at the hips.
- Slowly return to the start position without slouching or changing spinal alignment.

Bent Rear Delt Row

Muscles worked:

Latissimus Dorsi; Teres Major;
Rear Deltoids; Biceps

Position:

Standing—facing Power Rods®

Accessory:

Hand Grips

Pulleys:

Squat Pulley Frame

Leg Extension:

Removed

Success Tips

- Lift your chest, keep your knees bent and feet on Standing Platform.
- Do not bend your neck forwards or backwards during motion.
- Keep your spine aligned, abs tight and a slight arch in your lower back. Do not slouch.

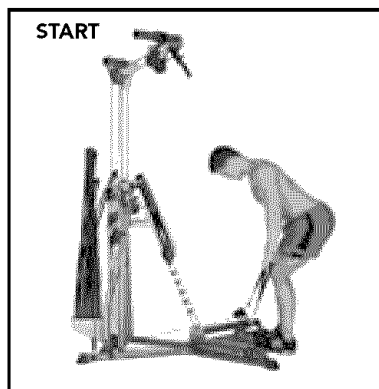
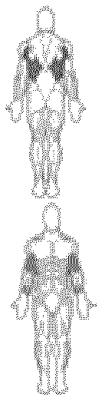

START

START

- Pivot forward from your hips, knees bent, spinal muscles tight.
- Grasp the Hand Grips, palms facing backward. Keep hands shoulder-width apart.
- Let your arms hang in the direction of the pulleys—do not lock your elbows.

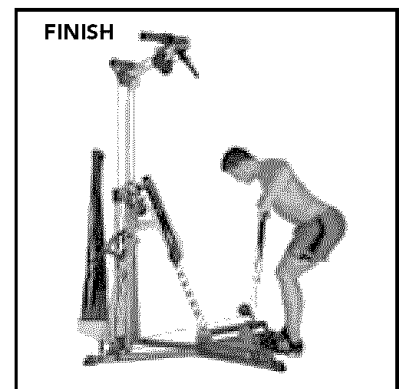

FINISH

ACTION

- Initiate movement by pulling your elbows back as you bring the Hand Grips upward to a point below your chest. Keep hands shoulder-width apart.
- Slowly return to start position, keeping your knees bent and your back flat.

Crossover Bent Rear Delt Row

Muscles worked:

Anterior and Middle Deltoids

Position:

Standing—facing Power Rods®

Accessory:

Hand Grips

Pulleys:

Squat Pulley Frame

Leg Extension:

Removed

Success Tips

- Lift your chest, keep your knees bent and feet on Standing Platform.
- Do not bend your neck forwards or backwards during motion.
- Keep your spine aligned, abs tight and a slight arch in your lower back. Do not slouch.
- Keep the lats tightened throughout the entire motion.

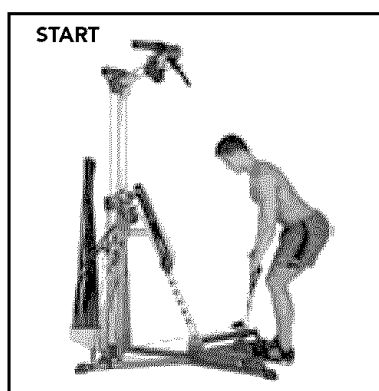
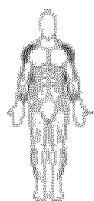

START

START

- Pivot forward from your hips, knees bent, spinal muscles tight.
- Cross your arms, reach down and grasp the Hand Grips (right Grip in left hand and vice versa), palms facing backward. Keep hands shoulder-width apart.
- Let your arms hang in the direction of the pulleys—do not lock elbow.

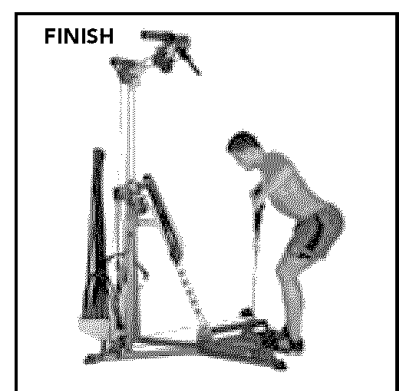

FINISH

ACTION

- Initiate movement by pulling your elbows back as you bring the Hand Grips upward and cross them over your chest. Keep your crossed hands shoulder-width apart.
- Slowly return to start position, keeping your knees bent and your back flat.

Seated Wide Lat Pulldowns—Shoulder Adduction (with elbow flexion)

Muscles worked:

Latissimus Dorsi; Teres Major;
Rear Deltoids

Position:

Seated—Facing Power Rods[®]

Accessory:

Lat Pulldown Bar

Pulleys:

Lat Cross Bars

Leg Extension:

Removed

Success Tips

- Lift your chest, keep your knees bent and feet on Standing Platform.
- Do not bend your neck forwards or backwards during motion.
- Keep your spine aligned, abs tight and a slight arch in your lower back. Do not slouch.
- If you can't complete motion with hands wide, bring your hands closer together.

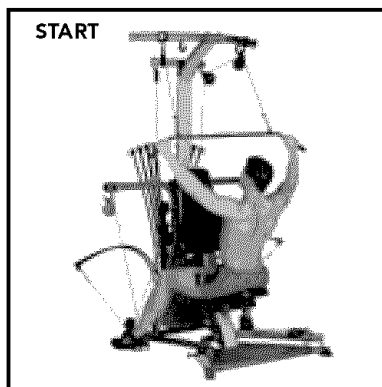

START

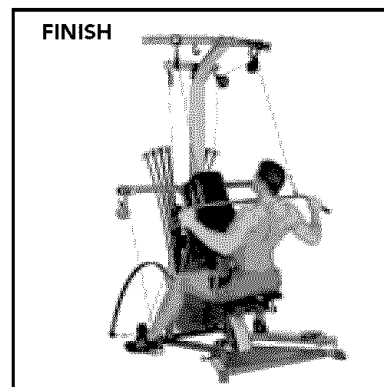

FINISH

START

- Grasp the Lat Pulldown Bar at a comfortable, wide grip, then sit, with your arms extending upward.
- You may position your thighs directly beneath the pulleys, but lean back slightly from hips.

ACTION

- Initiate the movement by pulling your shoulder blades downward and together, drawing your elbows down toward your hips and then inward into your trunk.
- The Lat Pulldown Bar may not touch your chest.
- Forearms should stay in line with the direction of the cables.
- Slowly return to the start position, without relaxing the tension in your shoulders.

Seated Narrow Lat Pulldowns with Lat Bar—Shoulder Extension (with elbow flexion)

Muscles worked:

Latissimus Dorsi; Teres Major;
Rear Deltoids; Biceps

Position:

Seated—Facing Power Rods[®]

Accessory:

Lat Pulldown Bar

Pulleys:

Lat Cross Bar

Leg Extension:

Removed

Success Tips

- Lift your chest, keep your knees bent and feet on Standing Platform.
- Do not bend your neck forwards or backwards during motion.
- Keep your spine aligned, abs tight and a slight arch in your lower back. Do not slouch.

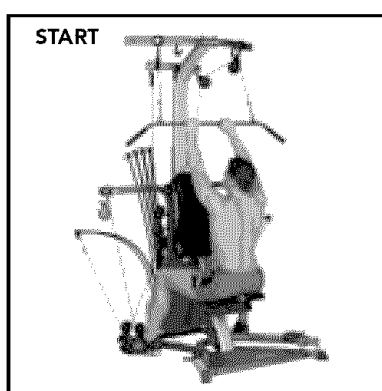
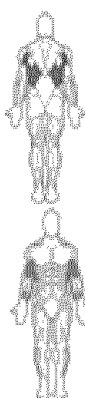

START

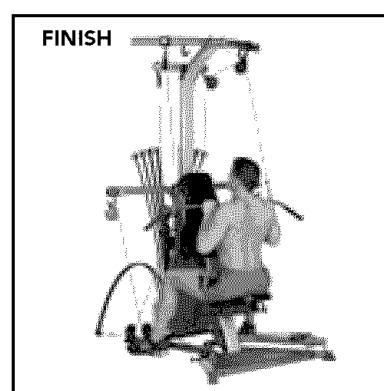

FINISH

START

- Grasp the Lat Pulldown Bar, keeping your hands next to each other, and then sit, with your arms extending upward, muscles relaxed and ready.
- You may position your thighs directly beneath the pulleys, but lean back slightly from hips.

ACTION

- Initiate the movement by pulling your shoulder blades downward and together, drawing your elbows down toward your hips and then inward into your trunk.
- The Lat Pulldown Bar may not touch your chest.
- Forearms should stay in line with the direction of the cables.
- Slowly return to the start position, without relaxing the tension in your shoulders.

Narrow Lat Pulldowns with Hand Grips—Shoulder Extension (with elbow flexion)

Muscles worked:

Latissimus Dorsi; Teres Major;
Rear Deltoids; Biceps

Position:

Seated—Facing Power Rods®

Accessory:

Hand Grips

Pulleys:

Lat Cross Bar—Narrow Pulleys

Leg Extension:

Removed

Success Tips

- Lift your chest, keep your knees bent and feet on Standing Platform.
- Do not bend your neck forwards or backwards during motion.
- Keep your spine aligned, abs tight and a slight arch in your lower back. Do not slouch

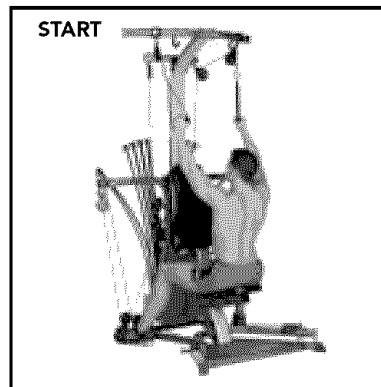
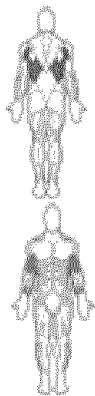

START

- Grasp the Hand Grips in both hands, as if they are one, larger Grip. Keep your palms facing each other throughout exercise.
- Sit, arms extending upward, muscles relaxed and ready.
- You may position your thighs directly beneath the pulleys, but lean back slightly from hips.

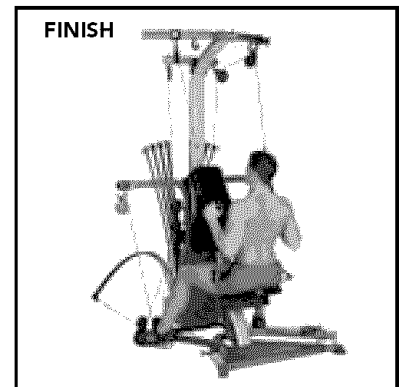

ACTION

- Initiate the movement by pulling your shoulder blades downward and together, drawing your elbows down toward your hips and then inward into your trunk.
- The Hand Grips may not touch your chest.
- Forearms should stay in line with the direction of the cables.
- Slowly return to the start position, without relaxing the tension in your shoulders.

Reverse Grip Pulldowns—Shoulder Extension (with elbow flexion)

Muscles worked:

Latissimus Dorsi; Teres Major;
Rear Deltoids; Biceps

Position:

Seated—Facing Power Rods®

Accessory:

Hand Grips

Pulleys:

Lat Cross Bar—Narrow Pulleys

Leg Extension:

Removed

Success Tips

- Lift your chest, keep your knees bent and feet on Standing Platform.
- Do not bend your neck forwards or backwards during motion.
- Keep your spine aligned, abs tight and a slight arch in your lower back. Do not slouch.

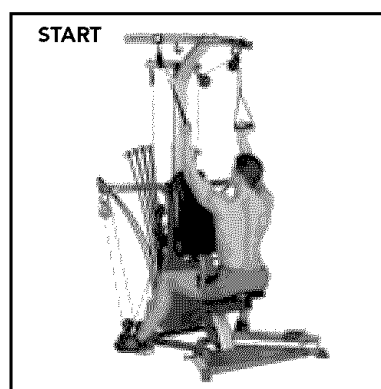
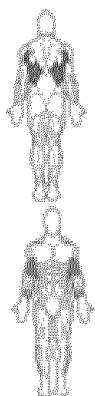

START

- Grasp the Hand Grips with an underhand grip (palms toward your face). Keep your palms facing outward throughout the exercise. Hands should be a comfortable distance apart.
- Sit, arms extending upward, muscles relaxed and ready.
- You may position your thighs directly beneath the pulleys, but lean back slightly from hips.

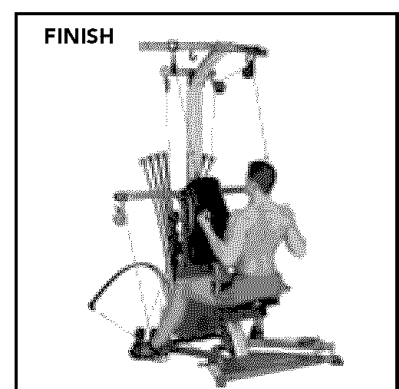

ACTION

- Initiate the movement by pulling your shoulder blades downward and together, drawing your elbows down toward your hips and then inward into your trunk.
- Shoulders should be fully depressed at end of movement.
- Forearms should stay in line with the direction of the cables.
- Slowly return to the start position, without relaxing the tension in your shoulders.

Crossover Wide Pulldowns—Shoulder Extension (with elbow flexion)

Muscles worked:

Latissimus Dorsi; Teres Major; Rear Deltoids; Pectoralis Major; Triceps

Position:

Seated—Facing Power Rods®

Accessory:

Hand Grips

Pulleys:

Lat Cross Bar—Wide Pulleys

Leg Extension:

Removed

Success Tips

- Lift your chest, keep your knees bent and feet on Standing Platform. Keep lats tightened.
- Do not bend your neck forwards or backwards during motion.
- Keep your spine aligned, abs tight and a slight arch in your lower back. Do not slouch.
- Do not lean backward as you pull.

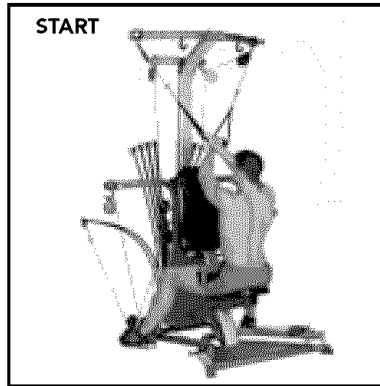
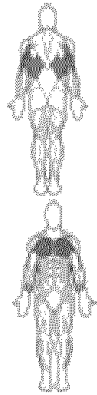

START

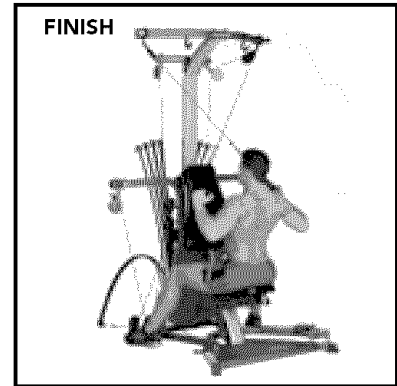

FINISH

START

- Cross your arms and grasp the Hand Grips (right Grip in left hand and vice versa).
- Sit, arms extending upward, muscles relaxed and ready.
- You may position your thighs directly beneath the pulleys, but lean back slightly from hips.

ACTION

- Initiate the movement by pulling your shoulder blades downward and together, drawing your elbows down toward your hips and then inward into your trunk.
- At end of motion, shoulders should be fully depressed.
- Forearms should stay in line with the direction of the cables.
- Slowly return to the start position, without relaxing the tension in your shoulders.

Crossover Narrow Pulldowns—Shoulder Extension (with elbow flexion)

Muscles worked:

Latissimus Dorsi; Teres Major; Rear Deltoids; Biceps

Position:

Seated—facing Power Rods®

Accessory:

Hand Grips

Pulleys:

Lat Cross Bar—Narrow Pulleys

Leg Extension:

Removed

Success Tips

- Lift your chest, keep your knees bent and feet on Standing Platform.
- Do not bend your neck forwards or backwards during motion.
- Keep your spine aligned, abs tight and a slight arch in your lower back. Do not slouch.

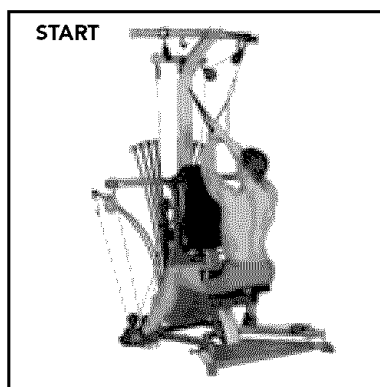
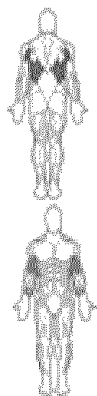

START

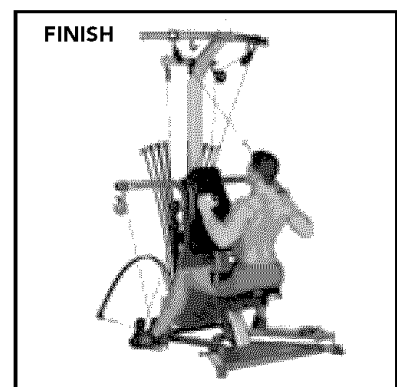

FINISH

START

- Cross your arms and grasp the Hand Grips (right Grip in left hand and vice versa).
- Sit, arms extending upward, muscles relaxed and ready.
- You may position your thighs directly beneath the pulleys, but lean back slightly from hips.

ACTION

- Initiate the movement by pulling your shoulder blades downward and together, drawing your elbows down toward your hips and then inward into your trunk.
- At end of motion, shoulders should be fully depressed.
- Forearms should stay in line with the direction of the cables.
- Slowly return to the start position, without relaxing the tension in your shoulders.

Pulldowns—Shoulder Adduction (with elbow flexion)

Muscles worked:

Latissimus Dorsi; Teres Major;
Rear Deltoids; Biceps

Position:

Standing—facing Power Rods[®]

Accessory:

Lat Pulldown Bar

Pulleys:

Lat Cross Bar

Leg Extension:

Removed

Success Tips

- Lift your chest, keep your knees bent and feet on Standing Platform.
- To determine the appropriate grip width for you, hold your arms straight out to your sides at shoulder height. Bend your elbows approximately 90°. Hands should be no wider apart than your elbows.
- Keep your spine aligned, abs tight and a slight arch in your lower back.

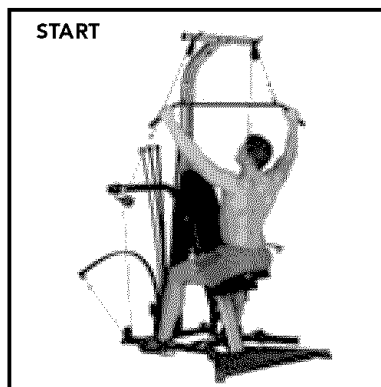
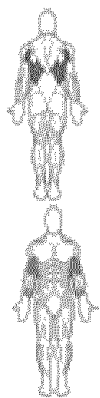

START

- Grasp the Lat Pulldown Bar with an overhanded grip (palms facing the floor), at the grip width determined by following the directions in the Success Tips.
- Keep your arms extended and muscles relaxed and ready.

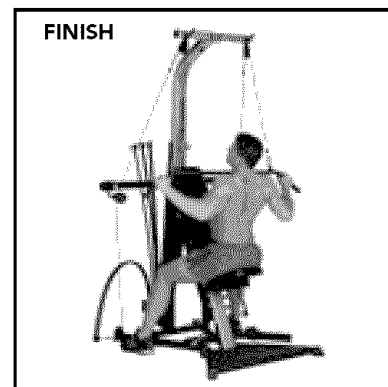

ACTION

- Initiate movement by pulling shoulder blades together while simultaneously drawing elbows down and inward.
- The Lat Pulldown Bar may not touch your chest. At the end of the motion, arms should be near your sides, shoulder blades fully depressed.
- Keep forearms in line with the Cables.
- Slowly return to start position.

Stiff-Arm Pulldown—Shoulder Extension (elbow stabilized)

Muscles worked:

Latissimus Dorsi; Teres Major; Rear Deltoids; Lower Trapezius; Biceps

Position:

Standing—facing Power Rods[®]

Accessory:

Lat Pulldown Bar

Pulleys:

Lat Cross Bar

Leg Extension:

Removed

Success Tips

- Keep your lats tightened throughout the entire motion.
- Keep your chest lifted and maintain spinal alignment, keeping a very slight arch in your lower back.
- Release your shoulder blades at the end of each rep. Initiate each new rep by depressing your shoulder blades.
- Keep your elbows nearly straight (do not lock elbows) throughout exercise.

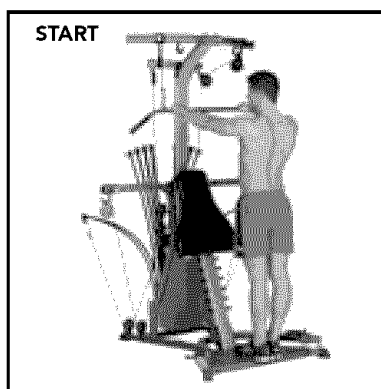
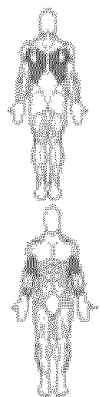

START

- Grasp the Lat Pulldown Bar with your palms facing down.
- Step back slightly, making sure that there is enough movement in the cable to complete your full range of motion with this exercise.
- Bend slightly from hips, lift chest and tighten your abs to stabilize spine.

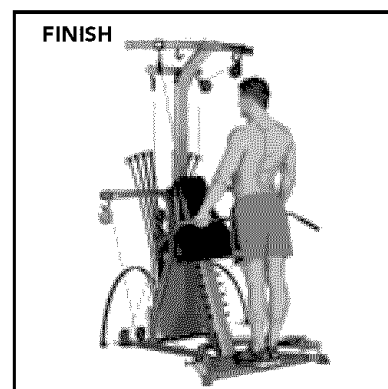

ACTION

- Initiate the movement by lowering your shoulder blades, bringing them down and together.
- Keep your arms straight, moving your hands downward in an arc and slowly in toward your thighs.
- Slowly return to the start position without relaxing muscle tension.

Standing Shoulder Pullover with Hand Grips—Elbow Stabilized

Muscles worked:

Latissimus Dorsi; Teres Major;
Rear Deltoids; Biceps; Triceps

Position:

Standing—facing Power Rods®

Accessory:

Hand Grips

Pulleys:

Lat Cross Bar

Leg Extension:

Removed

Success Tips

- Lift your chest, keep your knees bent and feet on Standing Platform.
- Keep your lats tightened throughout entire motion.
- Keep your spine aligned, abs tight and a slight arch in your lower back.
- Release your shoulder blades at the end of each rep. Initiate each new rep by depressing your shoulder blades.

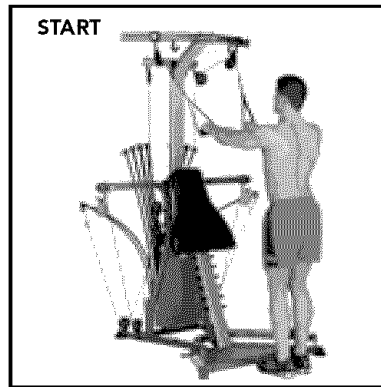
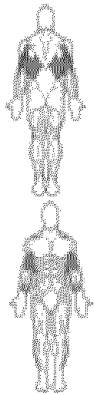

START

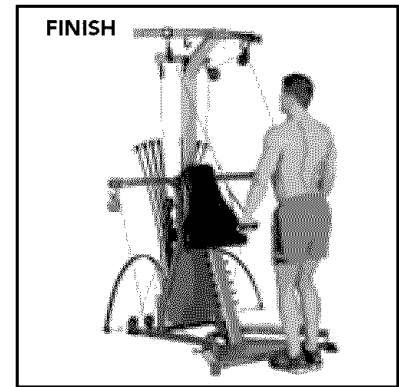

FINISH

START

- Grasp the Hand Grips, palms facing down, keeping hands shoulder-width apart.
- Tighten your abdominals to stabilize your spine while maintaining a slight arch in your lower back.

ACTION

- Initiate the movement by pulling your shoulder blades downwards and tightening your lats.
- Pull your arms in an arc into your sides, keeping them as steady as possible and using slow, controlled movement.
- Slowly return to the start position, allowing your arms and shoulder blades to relax without losing readiness.

Crossover Seated Lat Rows—Shoulder Extension (and elbow flexion)

Muscles worked:

Latissimus Dorsi; Teres Major;
Rear Deltoids; Biceps; Triceps

Position:

Seated on the floor—facing machine

Accessory:

Hand Grips

Pulleys:

Squat Pulley Frame

Leg Extension:

Removed

Success Tips

- Keep knees bent and feet braced against the Standing Platform.
- Do not bend your torso forward.
- Keep your chest lifted and maintain spinal alignment.
- Release your shoulder blades at the end of each rep. Initiate each new rep by pinching your shoulder blades.

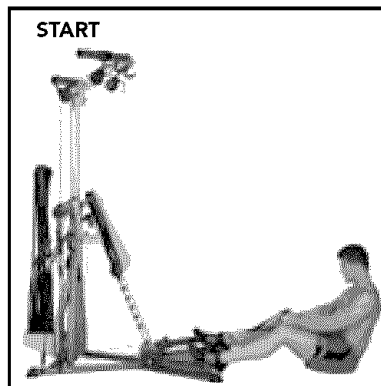
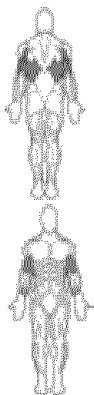

START

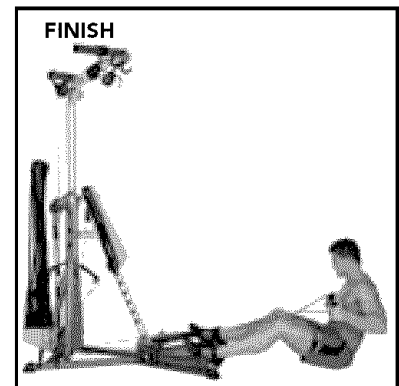

FINISH

START

- Cross your arms and grasp the Hand Grips (right Grip in left hand and vice versa), palms facing each other.
- Keep your spine as erect as possible.
- Place your heels on the edge of the Standing Platform and bend your knees comfortably.

ACTION

- Initiate the movement by pinching your shoulder blades together.
- Pull your upper arms downward and backward, brushing past the sides of the body while keeping your forearms pointing in the direction of the cable.
- Slowly return to the start position.

Seated Lat Rows—Shoulder Extension (and elbow flexion)

Muscles worked:

Latissimus Dorsi; Teres Major;
Rear Deltoids; Biceps

Position:

Seated on the floor—facing machine

Accessory:

Hand Grips

Pulleys:

Squat Pulley Frame

Leg Extension:

Removed

Success Tips

- Keep knees bent and feet braced against the Standing Platform.
- Do not bend your torso forward.
- Keep your chest lifted and maintain spinal alignment.
- Release your shoulder blades at the end of each rep. Initiate each new rep by pinching your shoulder blades

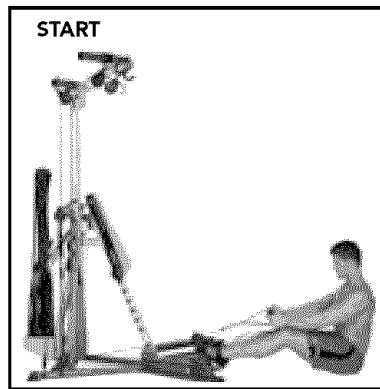

START

START

- Grasp the Hand Grips, palms facing each other.
- Keep your spine as erect as possible.
- Place your heels on the edge of the Standing Platform and bend your knees comfortably.

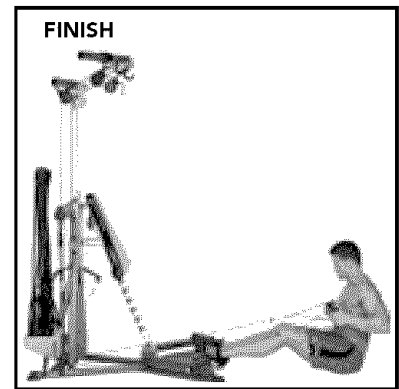

FINISH

ACTION

- Initiate the movement by pinching your shoulder blades together.
- Pull your upper arms downward and backward, brushing past the sides of the body while keeping your forearms pointing in the direction of the cable.
- Slowly return to the start position.

Reverse Grip Pulldown with Lat Bar

Muscles worked:

Latissimus Dorsi; Teres Major;
Rear Deltoids; Biceps

Position:

Seated—Facing Power Rods®

Accessory:

Lat Pulldown Bar

Pulleys:

Lat Cross Bar

Leg Extension:

Removed

Success Tips

- Lift your chest, keep your knees bent and feet on Standing Platform.
- Do not bend your neck forwards or backwards during motion.
- Keep your spine aligned, abs tight and a slight arch in your lower back. Do not slouch.

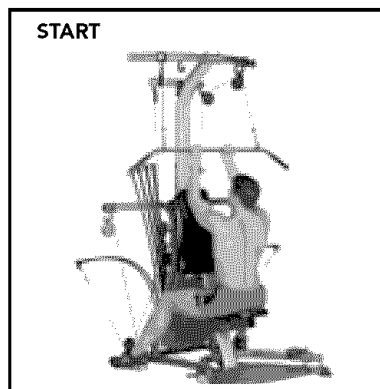

START

START

- Grasp the Lat Pulldown Bar, keeping your hands next to each other with an underhand grip, and then sit, with your arms extending upward, muscles relaxed and ready.
- You may position your thighs directly beneath the pulleys, but lean back slightly from hips.

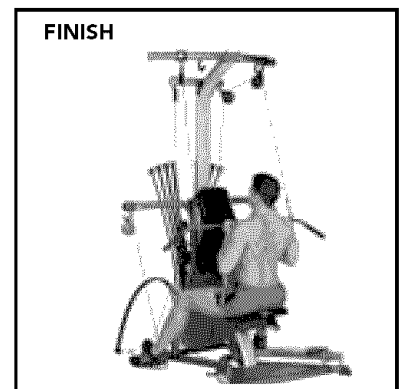

FINISH

ACTION

- Initiate the movement by pulling your shoulder blades downward and together, drawing your elbows down toward your hips and then inward into your trunk.
- The Lat Pulldown Bar may not touch your chest.
- Forearms should stay in line with the direction of the cables.
- Slowly return to the start position, without relaxing the tension in your shoulders.

Triceps Pushdown with Hand Grips—Elbow Extension

Muscles worked:

Triceps

Position:

Standing—facing Power Rods®

Accessory:

Hand Grips

Pulleys:

Lat Cross Bar

Leg Extension:

Removed

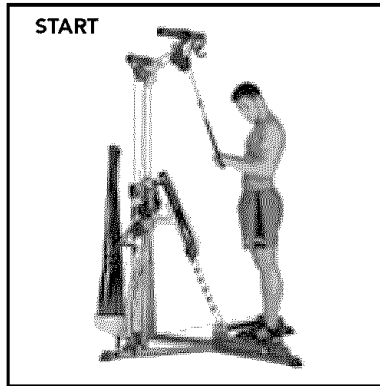

START

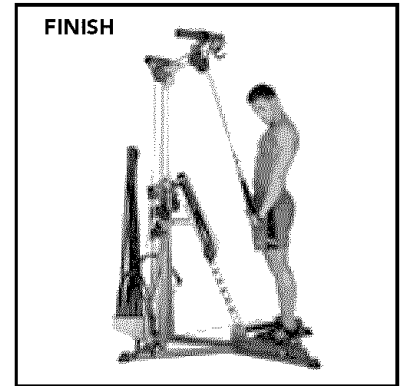

FINISH

Success Tips

- Keep your upper arms motionless and your wrists straight.
- Keep your chest lifted and maintain spinal alignment, keeping a very slight arch in your lower back.
- Tighten the triceps throughout the exercise, using controlled motion.
- Keep your knees bent and feet on Standing Platform.

START

- Grasp one or both of the Hand Grips, palms facing the floor.
- Keep hands and elbows approximately shoulder-width apart. Bend your elbows until hands are near shoulders.
- Bend slightly from your hips but maintain a stabilized spine.

ACTION

- Keeping your forearms and wrists stationary, straighten your elbows, bringing your hands down to your thighs, palms facing out.
- Stop the motion before your elbows are completely straight, and then reverse, slowly returning to the start position without relaxing muscle tension.

Triceps Hammer Pushdown—Elbow Extension

Muscles worked:

Triceps

Position:

Standing—facing Power Rods®

Accessory:

Hand Grips in “Hammer” Hold (see Page 4)

Pulleys:Front Lat Cross Bar

Leg Extension:

Removed

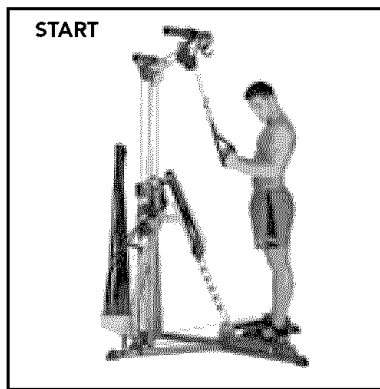

START

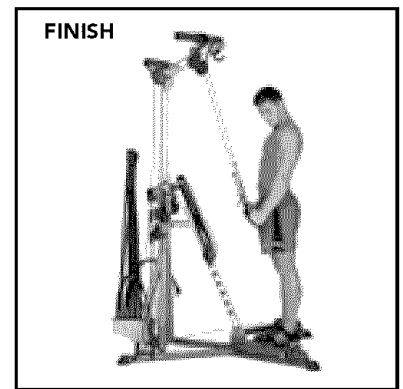

FINISH

Success Tips

- Keep your upper arms motionless and your wrists straight.
- Keep your chest lifted and maintain spinal alignment, keeping a very slight arch in your lower back.
- Tighten the triceps throughout the exercise, using controlled motion.
- Keep your knees bent and feet on Standing Platform.

START

- Grasp one or both of the Hand Grips, using the “Hammer” hold, palms facing inward.
- Keep hands and elbows approximately shoulder-width apart. Bend your elbows until hands are near shoulders.
- Bend slightly from your hips but maintain a stabilized spine.

ACTION

- Keeping your forearms and wrists stationary, straighten your elbows, bringing your hands down to your thighs, palms facing out.
- Stop the motion before your elbows are completely straight, and then reverse, slowly returning to the start position without relaxing muscle tension.

Triceps Pushdown with Lat Pulldown Bar—Elbow Extension

Muscles worked:

Triceps

Position:

Standing—facing Power Rods[®]

Accessory:

Lat Pulldown Bar

Pulleys:

Lat Cross Bar

Leg Extension:

Removed

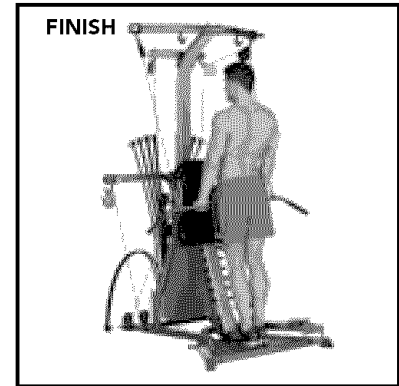
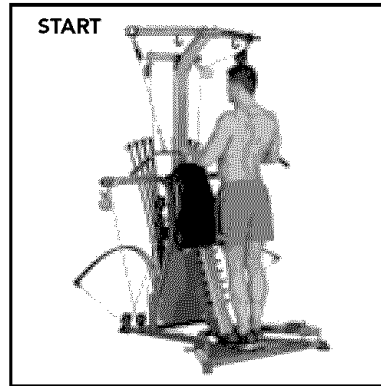

Success Tips

- Keep your upper arms motionless and your wrists straight.
- Keep your chest lifted and maintain spinal alignment, keeping a very slight arch in your lower back.
- Tighten the triceps throughout the exercise, using controlled motion.
- Keep your knees bent and feet on Standing Platform.

START

- Grasp the Lat Pulldown Bar, palms facing the floor.
- Keep hands and elbows approximately shoulder-width apart. Bend your elbows until hands are near shoulders.
- Bend slightly from your hips but maintain a stabilized spine.

ACTION

- Keeping your forearms and wrists stationary, straighten your elbows, bringing your hands down to your thighs, palms facing out.
- Stop the motion before your elbows are completely straight, and then reverse, slowly returning to the start position without relaxing muscle tension.

Single Arm Pushdown—Elbow Extension

Muscles worked:

Triceps

Position:

Standing—facing Power Rods[®]

Accessory:

Hand Grips

Pulleys:

Lat Cross Bars

Leg Extension:

Removed

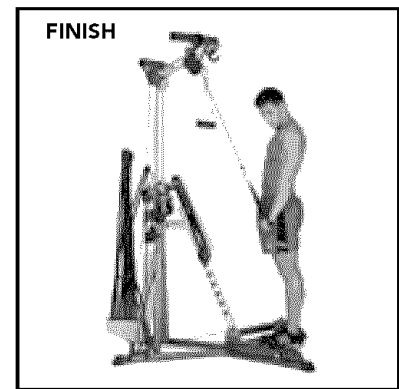
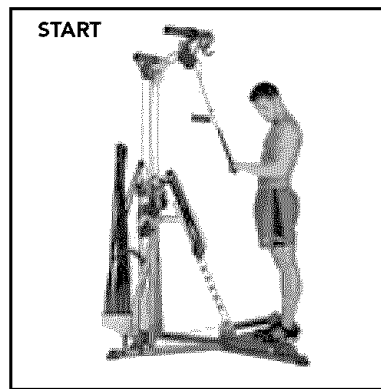

Success Tips

- Keep your upper arms motionless and your wrists straight.
- Keep your chest lifted and maintain spinal alignment, keeping a very slight arch in your lower back.
- Tighten the triceps throughout the exercise, using controlled motion.
- Keep your knees bent and feet on Standing Platform.

START

- Grasp one Hand Grip, palm facing downward.
- Stand approximately 1-2 feet from Lat Tower (adjust for comfort), but keeping feet on Standing Platform.
- Bring your arm in front of you, Hand Grip at chest level.
- Bend over slightly from hips, so that your shoulder is directly over your hand.

ACTION

- Keeping your upper arm stationary, elbow next to trunk, slowly push your arm downward in a gentle arc until your hand is near top of the thigh.
- Keeping your triceps tightened, slowly reverse the arcing motion, bringing the Hand Grip back to the start position.

Triceps Extension—Elbow Extension overhead

Muscles worked:

Triceps

Position:

Seated—facing outward

Accessory:

Hand Grips

Pulleys:

Center Cross Bar—Narrow Pulleys

Leg Extension:

Removed

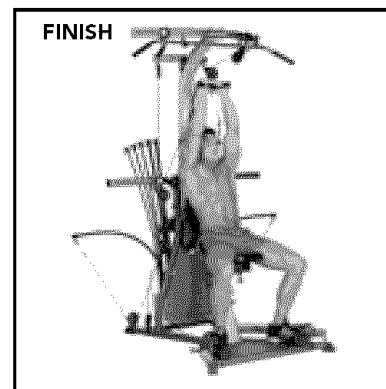
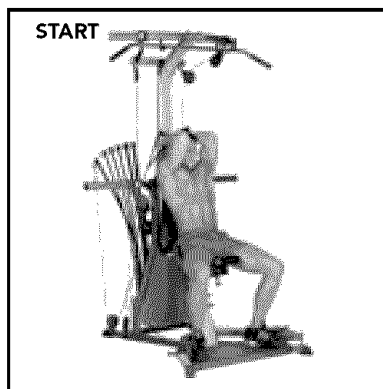

START

- Grasp one or both of the Hand Grips, palms facing outward.
- Draw arms up until elbows are pointing forward, hands behind shoulders.
- Keep your elbows “in line” with the cables throughout movement and your wrists straight.

ACTION

- Keeping your upper arms stationary, straighten your elbows, bringing your hands overhead, palms facing out.
- Stop your motion before your elbows are completely straight, and then reverse, slowly returning to the start position without relaxing muscle tension.

Success Tips

- Keep your upper arms motionless and your wrists straight.
- Keep your chest lifted and maintain spinal alignment, keeping a very slight arch in your lower back.
- Tighten the triceps throughout the exercise, using controlled motion.
- Keep your knees bent and feet on Standing Platform.

Cross Triceps Extension—Elbow Extension

Muscles worked:

Triceps

Position:

Seated—facing outward

Accessory:

Hand Grips

Pulleys:

Center Cross Bar—Narrow Pulleys

Leg Extension:

Removed

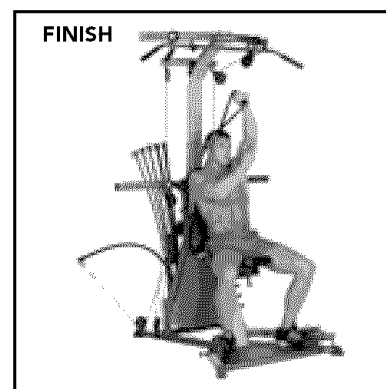
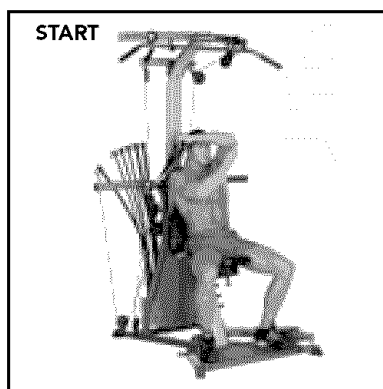

START

- Take one hand, reach over the opposite shoulder and grasp a Hand Grip.
- Bend and lower your elbow until your hand is in front of your chest, palm facing the floor and using a Hammer Grip.
- Spread your back and shoulders into the Seat Back Pad.
- Use your free hand to grasp the back of the active arm near the elbow to stabilize it.

ACTION

- Keeping your upper arm stationary, slowly straighten your elbow, bringing your hand across your body in an arcing motion across your chest.
- Stop the motion when your arm is straight (don't lock your elbow) and then slowly reverse the arcing motion, bringing your hand back to the start position.

Success Tips

- Keep your chest lifted and maintain a very slight arch in your lower back.
- Keep knees bent and feet flat on the Standing Platform.
- Keep your upper arms motionless and your wrists straight.
- Tighten the triceps throughout the exercise, using controlled motion throughout the exercise.

Hammer Triceps Extension

Muscles worked:

Triceps

Position:

Seated—facing outward

Accessory:

Hand Grips in “Hammer” Hold (see Page 4)

Pulleys:

Center Cross Bar—Narrow Pulleys

Leg Extension:

Removed

Success Tips

- Keep your upper arms motionless and your wrists straight.
- Keep your chest lifted and maintain spinal alignment, keeping a very slight arch in your lower back.
- Tighten the triceps throughout the exercise, using controlled motion.
- Keep your knees bent and feet on Standing Platform.

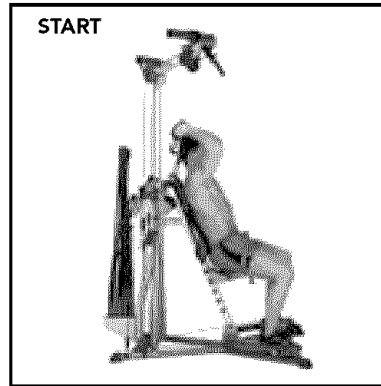

START

- Grasp one or both of the Hand Grips using the “Hammer” grip. Keep your palms facing each other.
- Draw arms up until elbows are pointing forward, hands behind shoulders.
- Keep your elbows “in line” with the cables throughout movement and your wrists straight.

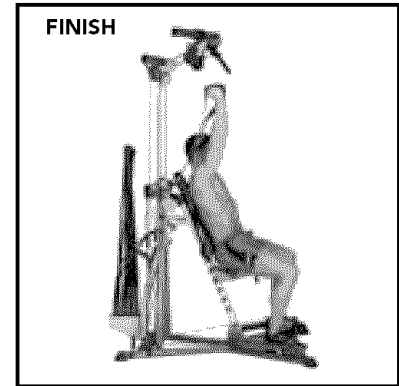

ACTION

- Keeping your upper arms stationary, straighten your elbows, bringing your hands overhead, palms facing each other.
- Stop the motion before your elbows are completely straight, and then reverse, slowly returning to the start position without relaxing muscle tension.

“Rope” Pushdown—Elbow Extension

Muscles worked:

Triceps

Position:

Standing—Facing Power Rods®

Accessory:

Hand Grips in “Hammer” Hold (see Page 4)

Pulleys:

Lat Cross Bar

Leg Extension:

Removed

Success Tips

- Keep your knees bent and feet on Standing Platform.
- Keep your upper arms motionless and your wrists straight.
- Keep your chest lifted, abs tight and maintain a slight arch in lower back.
- Tighten the triceps throughout the exercise, using controlled motion.

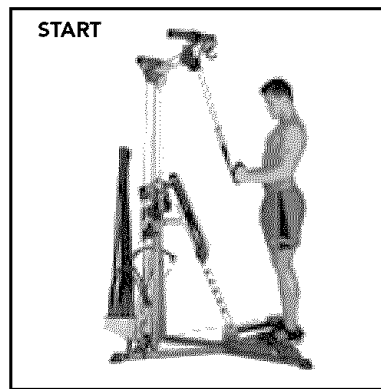

START

- Distance yourself from the Lat Tower, but keep your feet on the Standing Platform.
- Cross your arms and grasp the Hand Grip (right Grip in left hand and vice versa), palms facing down.
- Bring hands toward each other, in front of you, until they are positioned as if grabbing a rope.
- Keep your elbows bent, upper arms at your sides.

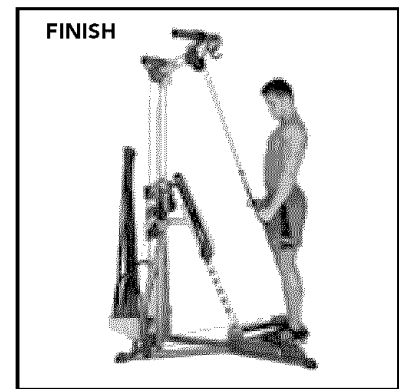

ACTION

- Keeping your upper arms stationary, elbows next to trunk, slowly straighten your arms downward, in a gentle arc, until hands are near tops of your thighs, hands and elbows straightened and directly in line with shoulders.
- Keeping your triceps tightened, slowly reverse the arcing motion and bring the Hand Grips back to the start position.

Seated Biceps Curl—Elbow Extension (in supination)

Muscles worked:

Biceps

Position:

Seated—facing outward

Accessory:

Hand Grips

Pulleys:

Squat Pulley Frame

Leg Extension:

Removed

Success Tips

- Keep knees bent, feet flat on the Standing Platform
- Keep your chest lifted, shoulders pinched together, and a very slight arch in your lower back.
- Keep your upper arms and shoulders motionless and your wrists straight.
- Lay your head back against the Seat Back Pad.

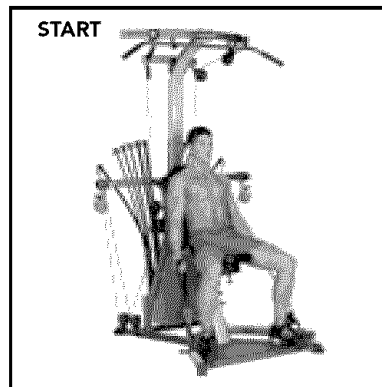

START

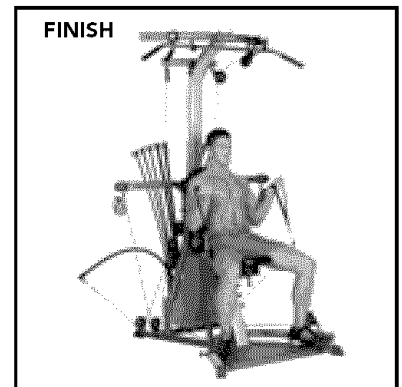

FINISH

START

- Grasp one or both Hand Grips, keeping your arms at your sides, forearms near your thighs.
- Keep your spine aligned throughout motion.

ACTION

- Curl your forearms toward the upper arms, keeping upper arms completely still.
- Keeping the motion fluid, slowly return to the start position without relaxing your biceps.

Standing Biceps Curl—Elbow Flexion (in supination)

Muscles worked:

Biceps

Position:

Standing—facing outward

Accessory:

Hand Grips

Pulleys:

Squat Pulley Frame

Leg Extension:

Removed

Success Tips

- Keep your knees bent and feet on Standing Platform.
- Keep your chest lifted, abs tight and a very slight arch in your lower back.
- Keep your elbows at your sides and your wrists straight.

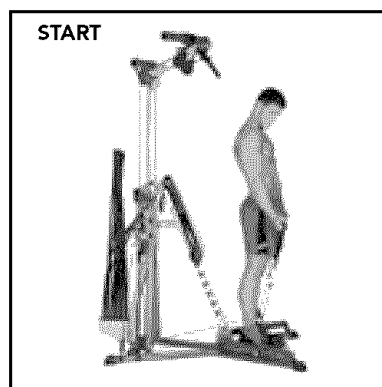

START

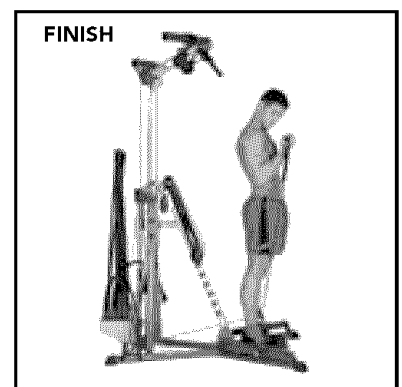

FINISH

START

- Reach down and grasp the Hand Grips, palms facing forward.
- Straighten, keeping your arms by your sides, elbows loose.

ACTION

- Keeping your upper arms stationary and your elbows at your sides, slowly curl the Hand Grips forward, then upward and in towards your shoulders.
- Slowly reverse the arcing motion bringing your hands back to the start position.

Concentration Biceps Curl—Flexion (in supination)

Muscles worked:

Biceps

Position:

Standing—facing right or left

Accessory:

Hand Grips

Pulleys:

Squat Pulley Frame

Leg Extension:

Removed

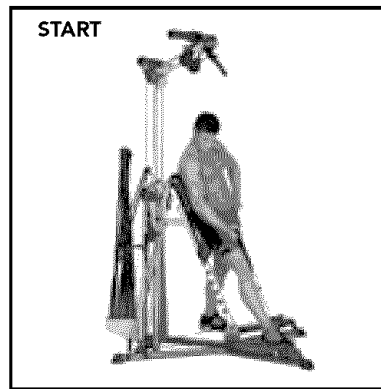
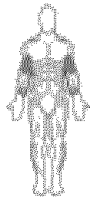

START

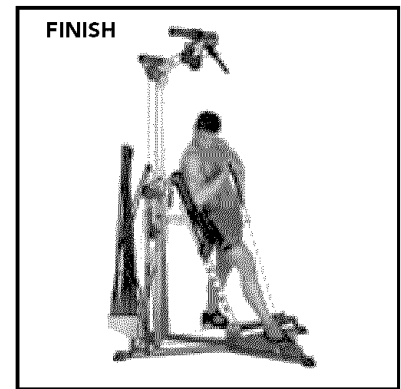

FINISH

Success Tips

- Keep your knees bent and feet on Standing Platform.
- Keep your upper body motionless and your wrists straight.
- Bend from the hips, never the waist.
- Elbow should point to the floor at all times.
- Keep chest lifted, trunk muscles tight and maintain a slight arch in lower back.
- Keep your spine aligned throughout movement.

START

- Stand on the Platform, one side facing the Power Rods®.
- With the inside hand, grasp the Hand Grip closest to you.
- Keeping your back straight, bend at your hips and knees until your trunk is parallel to the floor.
- Place your uninvolved hand on your thigh to stabilize.

ACTION

- Slowly curl your the Hand Grip away from the Cable and then upward toward your shoulder. Keep your upper arm completely motionless and elbow pointing directly at the floor at all times.
- Keeping your biceps tightened, slowly reverse the curling motion and bring your arm back to the start position.

Hammer Biceps Curl—Elbow Flexion (in supination)

Muscles worked:

Biceps; Brachialis; Brachioradialis

Position:

Standing—Facing Power Rods®

Accessory:

Hand Grips in “Hammer” Hold (see Page 4)

Pulleys:

Squat Pulley Frame

Leg Extension:

Removed

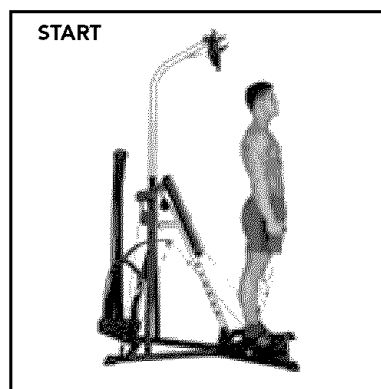

START

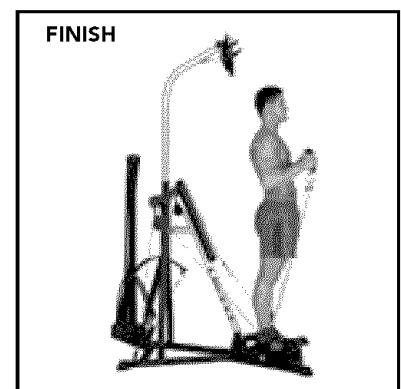

FINISH

Success Tips

- Keep your knees bent and feet on the Standing Platform
- Keep your chest lifted, shoulders pinched together, and a very slight arch in your lower back.
- Keep your upper arms and shoulders motionless and your wrists straight.

START

- Reach down and grasp the Hand Grips using the Hammer hold. Press your upper arms into your sides and bend your elbows until they are at 90° angles.
- Straighten your spine, keeping your upper arms by your sides, elbows loose.

ACTION

- Keeping your upper arms stationary and your elbows at your sides, slowly curl the Hand Grips forward, then upward and in towards your shoulders.
- Slowly reverse the arcing motion bringing your hands back to the start position.

Barbell Biceps Curl—Elbow Extension

Muscles worked:

Biceps

Position:

Standing—Facing outward

Accessory:

Squat Bar

Pulleys:

Squat Pulley Frame

Leg Extension:

Removed

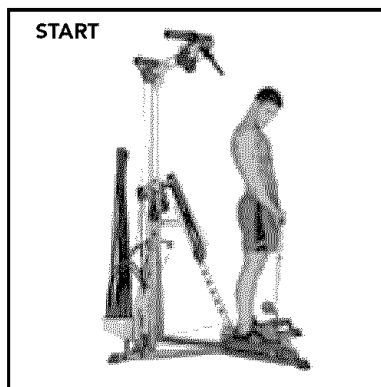

START

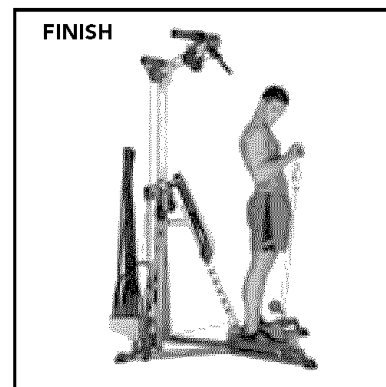

FINISH

START

- Grasp the Squat Bar, palms facing forward.
- Stand with your upper arms by your sides (not pressed tightly) and keep your elbows bent so that your forearms are at a 90° angle to your upper arms.

ACTION

- Slowly curl the Squat Bar forward and then upward toward your shoulders, keeping your elbows at your sides and your upper arms still.
- Slowly lower the Squat Bar back to the start position.

Success Tips

- Keep your knees bent and feet on Standing Platform.
- Keep your chest lifted, shoulders pinched together, and a very slight arch in your lower back.
- Keep your upper arms and shoulders motionless and your wrists straight.

Reverse Barbell Biceps Curl—Elbow Extension

Muscles worked:

Biceps

Position:

Standing—Facing outward

Accessory:

Squat Bar

Pulleys:

Squat Pulley Frame

Leg Extension:

Removed

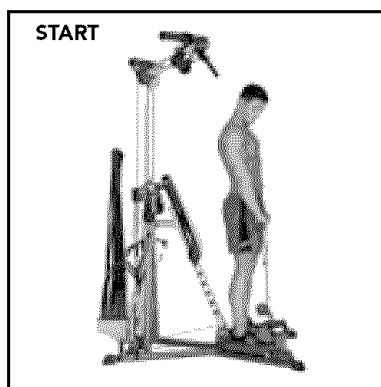
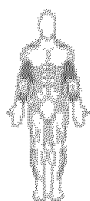

START

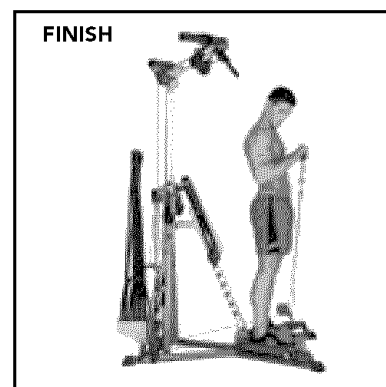

FINISH

START

- Grasp the Squat Bar, palms facing downward.
- Stand with your upper arms by your sides (not pressed tightly) and keep your elbows bent so that your forearms are at a 90° angle to your upper arms.

ACTION

- Slowly curl the back of your wrists in an arcing motion toward your shoulders, keeping your elbows at your sides and your upper arms still.
- Slowly lower the Squat Bar back to the start position.

Success Tips

- Keep your knees bent and feet on Standing Platform.
- Keep your chest lifted, shoulders pinched together, and a very slight arch in your lower back.
- Keep your upper arms and shoulders motionless and your wrists straight.

Seated Biceps Hammer Curl—Elbow Flexion

Muscles worked:

Brachioradialis; Biceps

Position:

Seated—facing outward

Accessory:

Hand Grips in “Hammer” Hold (see Page 4)

Pulleys:

Squat Pulley Frame

Leg Extension:

Removed

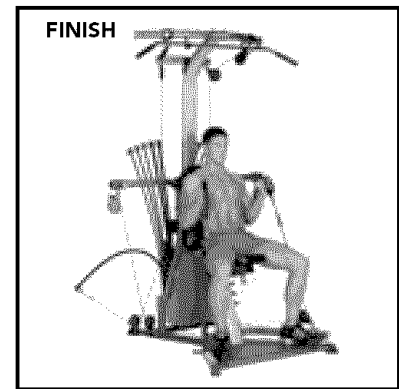
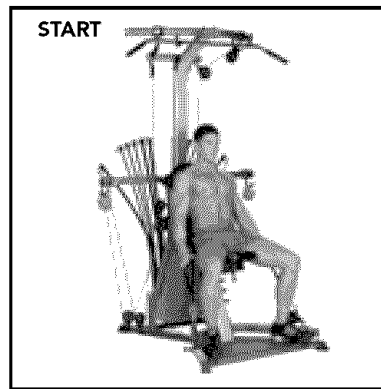

START

- Reach down and grasp the Hand Grips in the vertical “Hammer Grip” position.
- Straighten, keeping your upper arms and elbows by your sides, elbows loose. Forearms should be at a 90° angle to upper arms.

ACTION

- Curl the Hand Grips forward, then upward and in towards your shoulders.
- Keep your elbows at your sides and your upper arms completely still.
- Slowly reverse the curling motion and bring your arms back to start position.

Success Tips

- Keep your knees bent and feet on Standing Platform.
- Keep your upper body motionless, elbows at your sides and your wrists straight.
- Keep your trunk muscles tight and maintain a slight arch in lower back.
- Do not rock your upper body while bending your elbow.

Reverse Curl—Elbow Flexion (in pronation)

Muscles worked:

Brachialis; Brachioradialis; Biceps

Position:

Standing—facing outward

Accessory:

Hand Grips

Pulleys:

Squat Pulley Frame

Leg Extension:

Removed

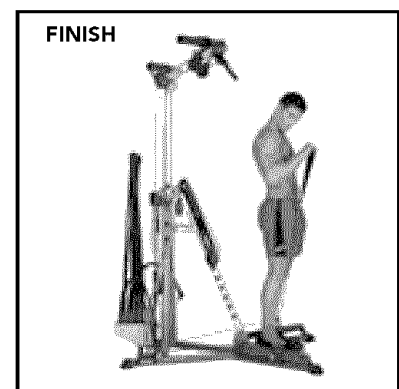
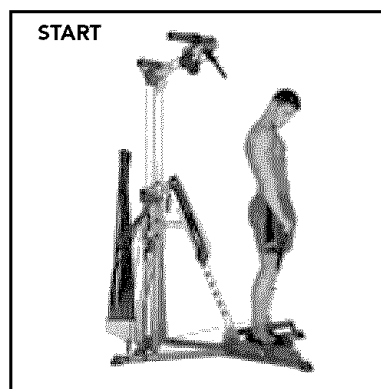

START

- Reach down and grasp the Hand Grips, palms facing backward.
- Straighten, keeping your upper arms and elbows by your sides, elbows loose. Bend your elbows until your forearms are between 45-90° angles with your upper arms.

ACTION

- Keeping your palms facing down, use your forearms to slowly bend your elbows, curling the Hand Grips forward, then upward and in towards your shoulders.
- Keep your elbows at your sides and your upper arms completely still.
- Slowly reverse the curling motion and bring your arms back to the start position.

Success Tips

- Keep your knees slightly bent and feet on Standing Platform.
- Keep your upper body motionless, elbows at your sides and your wrists straight.
- Keep your trunk muscles tight and maintain a slight arch in lower back.

Triceps Kickback

Muscles worked:

Triceps

Position:

Standing—facing Power Rods®

Accessory:

Hand Grips

Pulleys:

Center Cross Bar—Narrow Pulleys

Leg Extension:

Removed

Success Tips

- Keep your knees slightly bent and feet on Standing Platform.
- Keep your chest lifted, trunk muscles tightened, and a very slight arch in your lower back.
- Keep one hand on the Center Cross Bar to stabilize yourself throughout motion.
- Keep triceps tightened throughout the exercise.

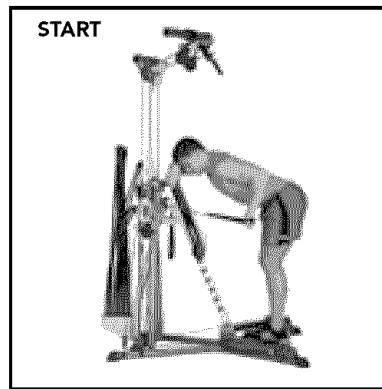

START

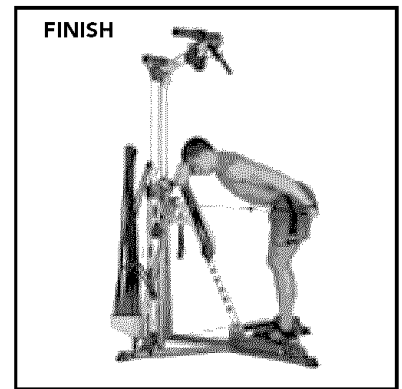

FINISH

START

- Reach down and grasp a Hand Grip in one hand, palm facing backward.
- Draw your elbow back until the forearm is at approximately a 45° angle from the upper arm.

ACTION

- Straighten your elbow, keeping your upper arm completely still.
- When arm is completely straight, slowly return to the start position.

Hammer Triceps Kickback—Elbow Extension

Muscles worked:

Triceps

Position:

Standing—facing Power Rods®

Accessory:

Hand Grips in “Hammer” Hold (see Page 4)

Pulleys:

Center Cross Bar—Narrow Pulleys

Leg Extension:

Removed

Success Tips

- Keep your knees slightly bent and feet on Standing Platform.
- Keep your chest lifted, trunk muscles tightened, and a very slight arch in your lower back.
- Keep one hand on the Center Cross Bar to stabilize yourself throughout motion.
- Keep triceps tightened throughout exercise and continue to hold Hand Grip in the “Hammer” hold.

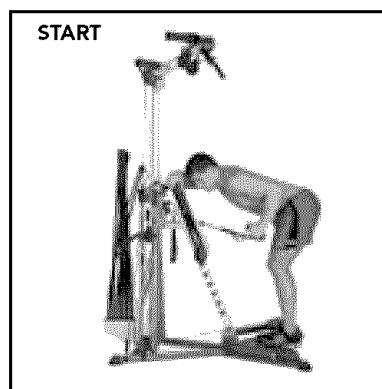

START

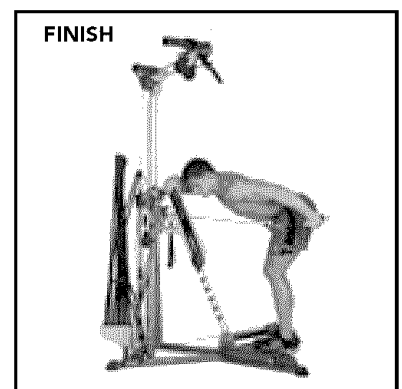

FINISH

START

- Reach down and grasp a Hand Grip in one hand, keeping your hand in the vertical “Hammer Grip” position.
- Draw your elbow back until the forearm is at approximately a 45° angle from the upper arm.

ACTION

- Straighten your elbow, keeping your upper arm completely still.
- When arm is completely straight, slowly return to the start position.

Arm Opposition Push-Pull

Muscles worked:

Biceps; Brachialis; Brachioradialis

Position:

Standing—facing Power Rods[®]

Accessory:

Hand Grips

Pulleys:

Lat Cross Bar and Squat Pulley Frame

Leg Extension:

Removed

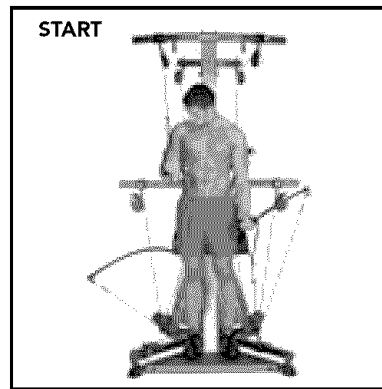

START

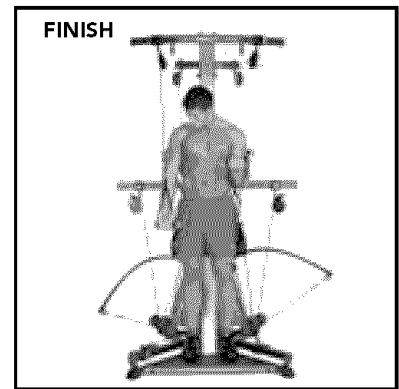

FINISH

Success Tips

- Lift your chest and keep your knees slightly bent and feet on Standing Platform.
- For this exercise, one Hand Grip is attached to a Lat Cable and one Hand Grip is attached to a Squat Cable. Alternate sides to build muscle evenly.
- Keep your upper body motionless, elbows at your sides and your wrists straight.
- Keep your trunk muscles tight and maintain a slight arch in lower back.

START

- Grasp the Hand Grips, keeping the one attached to the Lat Tower in an overhand grip and the one attached to the Squat Cable in an underhand grip.
- Straighten the Squat Cable arm and bend the Lat Cable arm at a 90° angle from your upper arm.

ACTION

- Slowly raise the Squat Cable arm while simultaneously lowering the Lat Cable arm, until each arm has reached full possible extension in opposition to each other.
- Slowly reverse, returning to start position.

Upper Body Opposition Push-Pull

Muscles worked:

Middle Deltoids; Supraspinatus; Trapezius; Biceps; Abs

Position:

Seated—facing outward

Accessory:

Hand Grips

Pulleys:

Lat Cross Bar and Center Cross Bar

Leg Extension:

Removed

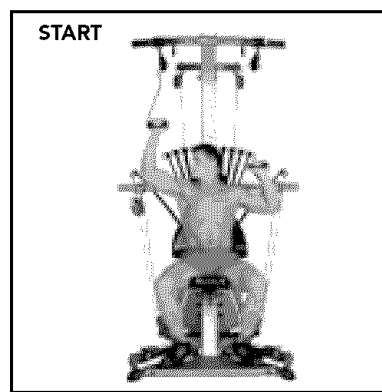
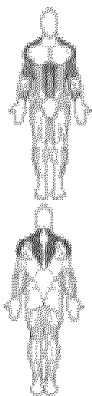

START

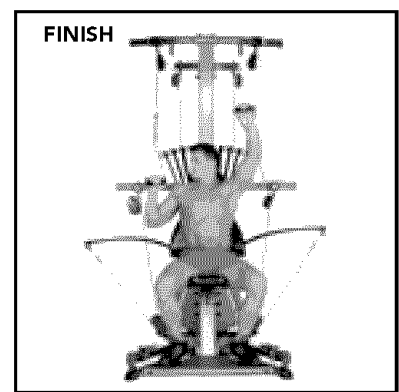

FINISH

Success Tips

- Lift your chest and keep your knees bent and feet on Standing Platform.
- For this exercise, one Hand Grip is attached to a Lat Cable and one Hand Grip is attached to a Rod Cable. Alternate sides to build muscle evenly.
- Keep your upper body motionless, elbows at your sides and your wrists straight.
- Keep your trunk muscles tight and maintain a slight arch in lower back.

START

- Grasp the Hand Grips, keeping the one attached to the Lat Tower in an overhand grip and the one attached to the Rod Cable in an underhand grip.
- Bend your forearms at a 90° angle from your upper arms, which should be at 90° angles from your torso.

ACTION

- Slowly raise the Rod Cable arm while simultaneously lowering the Lat Cable arm, until each arm has reached full possible extension in opposition to each other.
- Slowly reverse, returning to start position.

Wrist Extension

Muscles worked:

Forearms

Position:

Standing—facing Power Rods®

Accessory:

Hand Grips

Pulleys:

Squat Pulley Frame

Leg Extension:

Removed

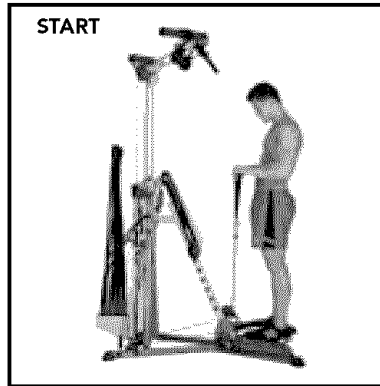

START

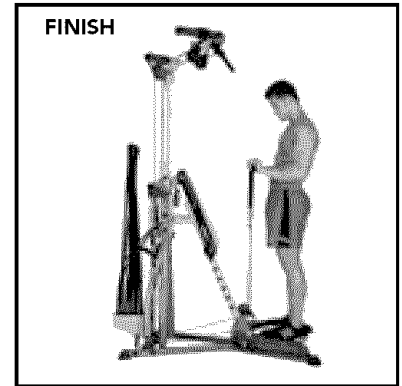

FINISH

START

- Grasp the Hand Grips, palm facing down, keeping your elbows flared slightly to the side, elbows bent approximately 90°.

ACTION

- Slowly curl the back of your fists backward towards your forearms.
- Stop when wrists are 90° from forearms or when you experience discomfort.
- Slowly return to the start position.

Success Tips

- Keep your knees slightly bent and feet on Standing Platform.
- Move slowly and keep tension in the back of the forearms at all times.
- Keep your chest lifted, trunk muscles tightened, and a very slight arch in your lower back.
- You may perform this exercise one arm at a time to make it easier to focus and isolate the back of your forearms, or with both arms simultaneously to save time.

Wrist Curl—with Wrist Flexion

Muscles worked:

Biceps; Forearms

Position:

Standing—Facing Power Rods®

Accessory:

Hand Grips

Pulleys:

Squat Pulley Frame

Leg Extension:

Removed

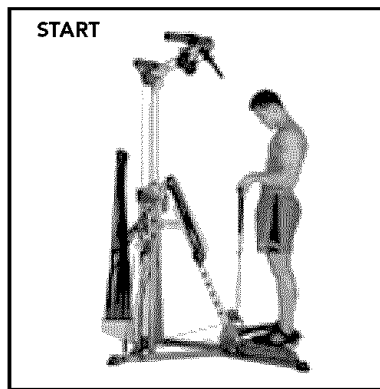
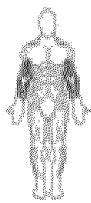

START

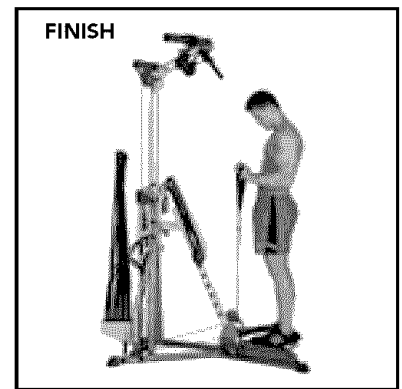

FINISH

START

- Reach down and grasp the Hand Grips, palms facing forward, fingertips down.
- Straighten, keeping your upper arms and elbows by your sides, elbows loose.
- Bend your elbows 90°, palms up, and maintain that position throughout the entire exercise.

ACTION

- With your upper arms stationary and your elbows at your sides, slowly curl your fists toward the front of your forearms.
- Keeping your forearms still, slowly let your fists return to the start position.

Success Tips

- Keep your chest lifted, trunk muscles tight and a very slight arch in your lower back.
- Move slowly, keeping tension in the front of your forearms at all times.
- Do not increase or decrease the bend in your elbow during this exercise—keep all motion in the wrist.
- Do not rock your body back and forth during wrist motion.

Resisted Dip—Elbow Extension**Muscles worked:**

Triceps

Position:

Standing—facing outward

Accessory:

Hand Grips

Pulleys:

Lat Cross Bar

Leg Extension:

Removed

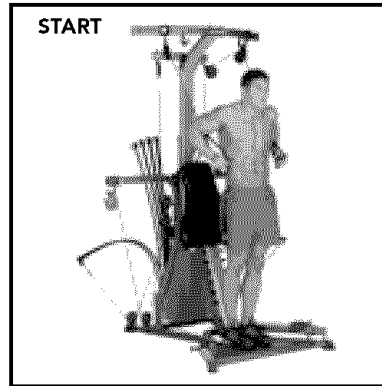
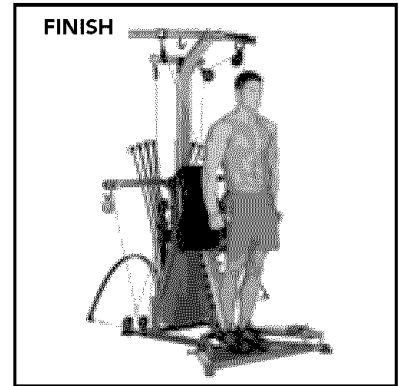
**START****FINISH****Success Tips**

- Lift your chest, keep your knees slightly bent and feet on Standing Platform.
- Keep your back straight and knees slightly bent.
- Keep your abs tight throughout entire motion and maintain good spinal alignment.

START

- Reach up and grasp the Hand Grips, palms facing the floor, keeping your thumbs on the inside, toward your body.
- Cable should be between your arms and your body.
- Upper arms should be at a 90° angle from torso.

ACTION

- Straighten your arms downward, focusing on not moving your elbows down or inward.
- Slowly reverse the motion, returning to the start position without relaxing the tension in the back shoulder muscles.

Seated (Resisted) Abdominal Crunch—Spinal Flexion

Muscles worked:

Rectus Abdominus; Obliques

Position:

Seated—facing outward

Accessory:

Hand Grips

Pulleys:

Center Cross Bar—Narrow Pulleys

Leg Extension:

Removed

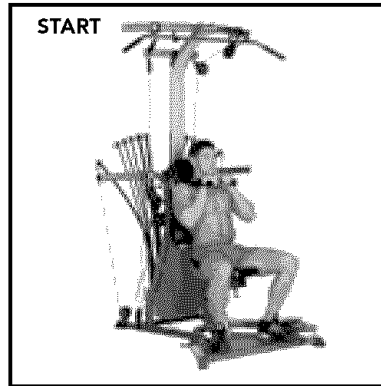

START

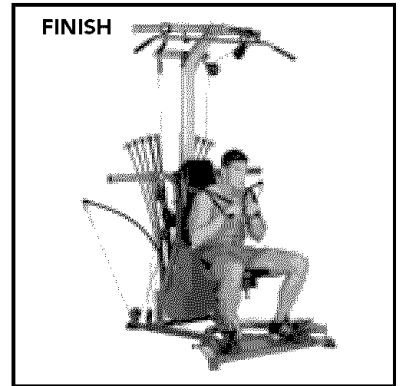

FINISH

START

- Grasp the Hand Grips in both hands, drawing them over your shoulders. Rest the back of your fists on your chest or shoulders, palms facing up.
- Lower back can start out flat or in a normal arch, knees and hips are bent and feet should be flat on the Standing Platform.

ACTION

- Tighten your abs and curl only your torso, slowly moving your ribs toward your hips. Move as far as you can without moving your hips or neck.
- Do not allow your lower back to lose contact with the bench during this entire exercise.
- Slowly reverse the motion, returning to the start position without relaxing your abs.

Success Tips

- Lift your chest, keep your knees slightly bent and feet on Standing Platform.
- Do not lift your head or chin—your head should follow the rib motion rather than lead it. Maintain normal neck posture.
- Tighten your abs through the entire exercise, rest only at the end of each set.
- Move slowly to eliminate momentum.
- Allow exhalation up and inhalation down without exaggerating breathing.

Seated (Resisted) Oblique Abdominal Crunch—Spinal Flexion/Rotation

Muscles worked:

Rectus Abdominus; Obliques

Position:

Seated—facing outward

Accessory:

Hand Grips

Pulleys:

Center Cross Bar—Narrow Pulleys

Leg Extension:

Removed

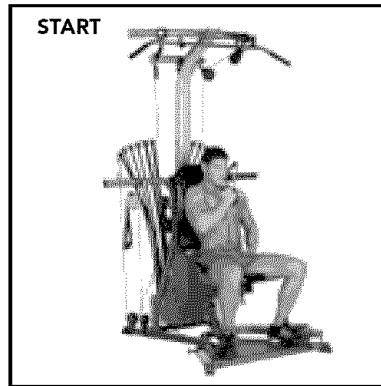

START

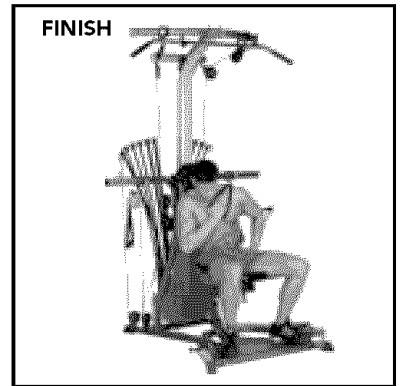

FINISH

START

- Cross one arm over the opposite shoulder, grasp a Hand Grip, and rest the hand on your shoulder or chest, palm facing down.
- Lower back can start out flat or in a normal arch, knees and hips are bent and feet should be flat on the Standing Platform.

ACTION

- Tighten your abs on the side with the active arm, focusing on the side of your ribs to the front of your pelvis on that side.
- Slowly move diagonally, rotating torso away from the side holding the Hand Grip, ribs turned toward the front of your pelvis.
- Crunch as deeply as you can, keeping lower back on bench.
- Slowly reverse to the start position without resting.

Success Tips

- Do not lift your head or chin—your head should follow the rib motion rather than lead it. Maintain normal neck posture.
- Tighten your abs through the entire exercise, rest only at the end of each set.
- Move slowly to eliminate momentum.
- Allow exhalation up and inhalation down without exaggerating breathing.

Trunk Rotation**Muscles worked:**

Rectus Abdominus; Obliques;
Serratus Anterior

Position:

Standing—facing right or left

Accessory:

Hand Grips

Pulleys:

Center Cross Bar—Narrow Pulleys

Leg Extension:

Removed

Success Tips

- Keep your knees slightly bent and feet on Standing Platform.
- This exercise must be performed correctly—failure to do so could result in injury. Use only low weight Rods.
- Keep all motion in your torso.
- Move only as far as your muscles will take you—do not use momentum to increase your range of motion.

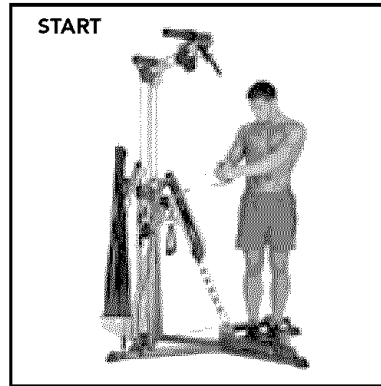
**START**

- Stand with one side toward the Power Rods®. Grasp the Hand Grip closest to you with both hands.
- Raise both arms up near shoulder level, hands extended over the leg closest to the Power Rods®.
- Keep your elbows slightly bent.

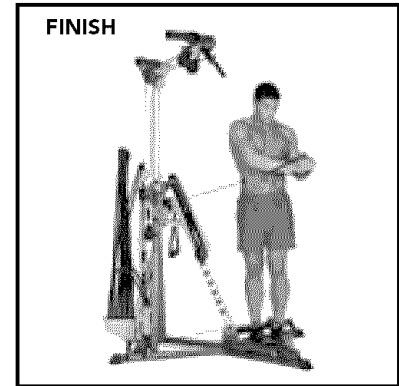
**ACTION**

- Tighten your entire abdominal area and slowly rotate your rib cage and arms away from the Power Rods® 30-40°, as if you were rotating with a rod through the middle of your spine.
- Slowly reverse the motion, returning to the start position without relaxing muscle tension.

Leg Extension

Muscles worked:

Quadriceps

Position:

Seated—facing outward

Accessory:

None

Pulleys:

Squat Pulley Frame

Leg Extension:

Engaged

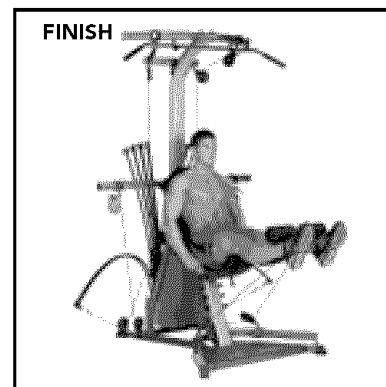
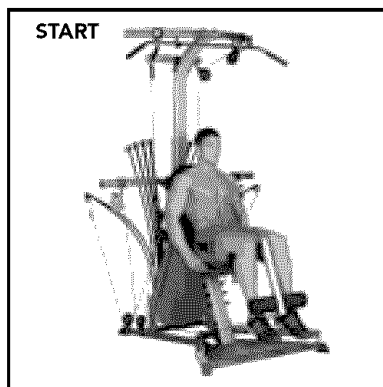

START

- Put your legs over the Leg Extension, with your knees near the pivot point and the lower roller pads in front of your shins (see start image above).
- Keep your thighs hip-width apart, knees pointing forward.
- Grasp the sides of the seat to stabilize yourself.

ACTION

- Tighten your quads and slowly straighten your legs, moving your feet forward then upward until your legs are completely straight and your kneecaps point upward to the ceiling.
- Slowly reverse the motion, returning to the start position without relaxing your quads.

Success Tips

- Use slow, controlled motion—do not “kick” into the extension.
- Do not let your knees rotate outward during the exercise. Keep kneecaps pointing up and straight forward.
- Sit up straight, chest lifted, abs tight and a slight arch in your lower back.

Squat

Muscles worked:

All Leg Muscles; Gluteus Maximus

Position:

Standing—facing outward

Accessory:

Squat Bar with Straps

Pulleys:

Squat Pulley Frame

Leg Extension:

Removed

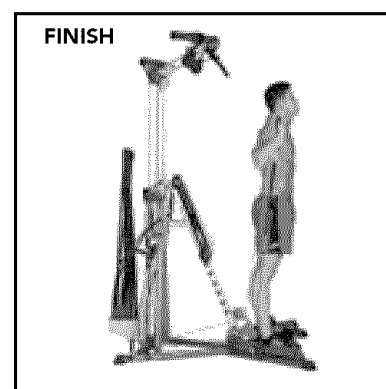
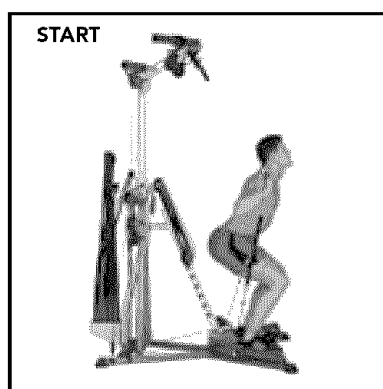
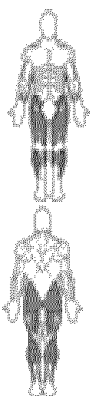

START

- Stand with your feet about shoulder-width apart.
- Squat down and place the Squat Bar across your shoulders—adjust the straps to make sure you have resistance from the start of the movement.

ACTION

- Slowly rise to a standing position, keeping your knees slightly bent. Do not lock your knees.
- Slowly return to the start position without relaxing your quadriceps.
- Do not allow your knees to exceed a 90° angle.

Success Tips

- Keep your chest lifted, spine aligned, abs tight and a slight arch in your lower back.
- Bend at the hips—do not use your waist or lower back.
- Keep your abs tightened throughout motion and knees pointed forward.
- Never step off of Standing Platform using Power Rod® resistance.

Calf Raise—Ankle Plantarflexion (knee stabilized)

Muscles worked:

Gastrocnemius; Soleus

Position:

Standing—facing Power Rods®

Accessory:

Hand Grips

Pulleys:

Squat Pulley Platform—Standard Pulley

Leg Extension:

Removed

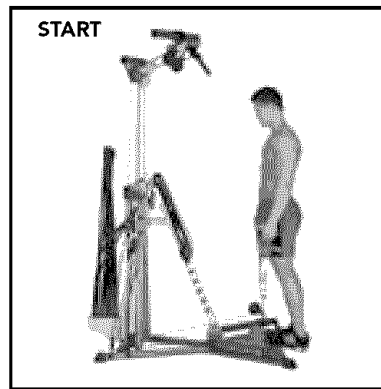

START

- Stand with your toes on the Standing Platform, heels hanging over the edge.
- Use the Hand Grips in both hands as resistance and as a balance stabilizer.

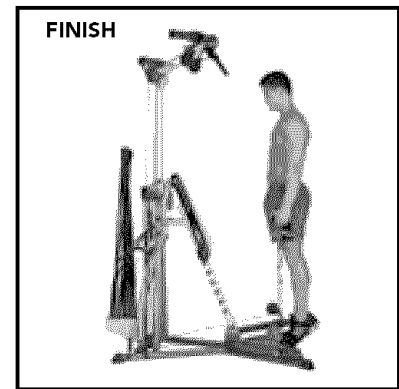

ACTION

- Slowly press the balls of your feet into the Standing Platform and lift your heels upward.
- Then, maintaining tension, slowly return to the start position.

Success Tips

- Keep your knees slightly bent and toes/balls of feet on Standing Platform.
- Do not lose contact between the balls of your feet and the Standing Platform.
- Keep your chest lifted, spine aligned, abs tight and slight arch in your lower back.
- Do not lift your hips or excessively arch your back.
- Do not change hip or knee position—ONLY ankle motion should be used.

Single Leg Calf Raise—Ankle Plantarflexion (knee stabilized)

Muscles worked:

Gastrocnemius; Soleus

Position:

Standing—facing Power Rods®

Accessory:

Hand Grips

Pulleys:

Squat Pulley Platform—Standard Pulley

Leg Extension:

Removed

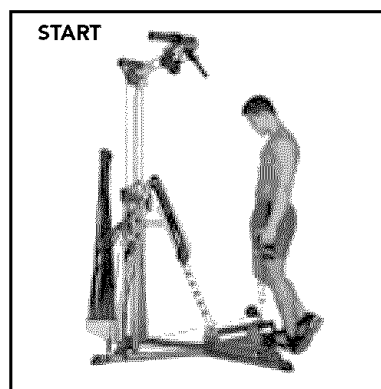

START

- Stand on one foot, with your toes/balls of feet on the Standing Platform, heels hanging over the edge.
- Use the Hand Grips in both hands as resistance and as a balance stabilizer.
- Keep the unused leg out of the way, do not use it to build momentum.

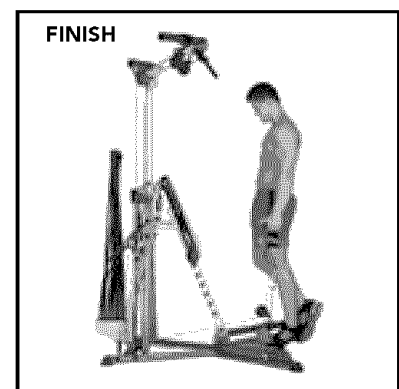

ACTION

- Slowly press the ball of your foot into the Standing Platform and lift your heel upward.
- Then, maintaining tension, slowly return to the start position.

Success Tips

- Do not lose contact with the balls of your foot and the Standing Platform during motion.
- Keep your chest lifted, spine aligned, abs tight and a slight arch in your lower back.
- Do not lift your hips or excessively arch your back.
- Do not change hip or knee position—ONLY ankle motion should be used.

Standing Hip Extension—(knee flexed)

Muscles worked:

Gluteus Maximus

Position:

Standing—facing Power Rods®

Accessory:

Hand Grip on Arch of Foot (see Page 4)

Pulleys:

Squat Pulley Frame—Standard Pulleys

Leg Extension:

Removed

Success Tips

- Keep your knees slightly bent and support foot on Standing Platform.
- Keep your chest lifted, spine aligned, abs tight and a very slight arch in your lower back.
- Do not bend from waist or lower back.
- Keep your knee stabilized in the 90° angle position.

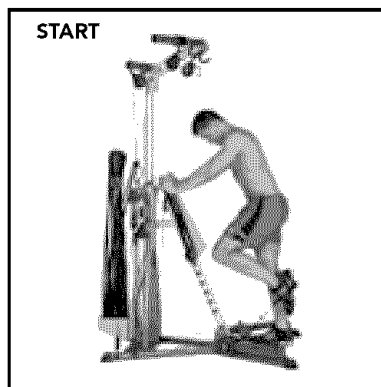

START

START

- Secure the Hand Grip around the arch of your foot. Bend this leg approximately 90°.
- Bend forward 30-40° from your hips (not your waist) and very slightly bend the knee of your supporting leg.
- Hold onto the Seat Back Pad to stabilize yourself.

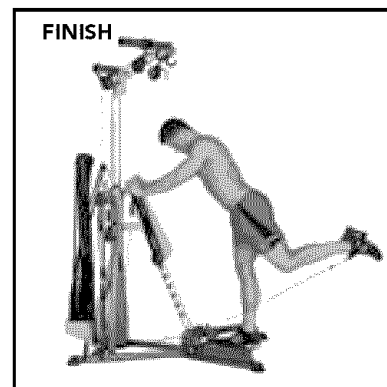

FINISH

ACTION

- Initiate the movement by tightening your glutes and slowly pivoting your leg from your hip. Move your entire leg backward, keeping your knee steady at a 90° angle.
- Slowly move your leg as far as you can, without allowing any movement at the waist, knee or lower back.
- Slowly return to start position.

Standing Hip Extension—(knee stabilized)

Muscles worked:

Gluteus Maximus

Position:

Standing—facing Power Rods®

Accessory:

Hand Grip on Arch of Foot (see Page 4)

Pulleys:

Squat Pulley Frame—Standard Pulleys

Leg Extension:

Removed

Success Tips

- Keep your knees slightly bent and support foot on Standing Platform.
- Keep your chest lifted, spine aligned, abs tight and a very slight arch in your lower back.
- Do not bend from waist or lower back.
- Keep working leg straight or only very slightly bent.

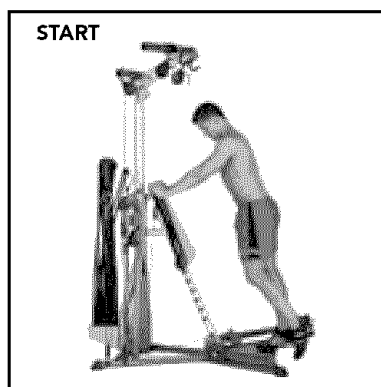

START

START

- Secure the Hand Grip around the arch of your foot. Keep this leg straight, but not locked at the knee.
- Bend forward 30-40° from your hips (not your waist) and very slightly bend the knee of your supporting leg.
- Hold onto the Seat Back Pad to stabilize yourself.

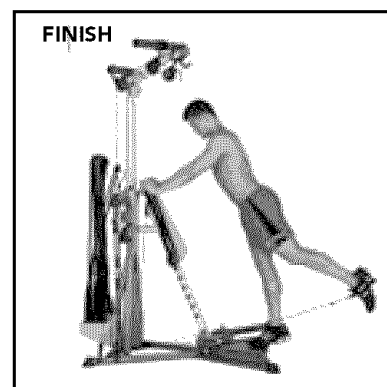

FINISH

ACTION

- Initiate the movement by tightening your glutes and slowly pivoting your leg from your hip. Move your entire leg backward and then lift it slightly behind you.
- Slowly move your leg as far as you can, without allowing any movement at the waist, knee or lower back.
- Slowly return to start position.

Standing Hip Abduction

Muscles worked:

Gluteus Medius

Position:

Stand—facing left or right

Accessory:

Hand Grip on Ankle (see Page 4)

Pulleys:

Squat Pulley Frame—Standard Pulleys

Leg Extension:

Removed

Success Tips

- Keep your chest lifted, spine aligned, abs tight and a slight arch in your lower back.
- This exercise does not burn fat from hips but builds strength and stability.
- Keep working leg straight or only very slightly bent and your hips level.
- Use only a small range of motion.

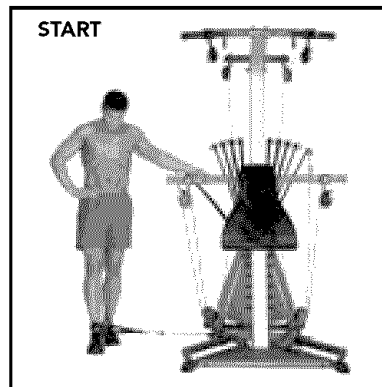

START

- Secure Hand Grips over the ankle furthest from the Power Rods®. Keep leg straightened, but knee loose.
- Adjust your position so that there is some tension in the cables at the start of this exercise.
- You may use your hand on the Seat Back Pad or Center Cross Bar to stabilize movement.

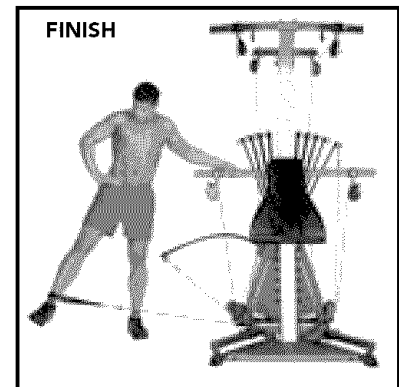

ACTION

- Slowly move the attached leg outward, away from the Power Rods®, at a 30–45° angle, keeping your hips and spine motionless.
- Slowly return to the start position without relaxing tension in your leg.
- Keep your hips level during movement.

Standing Hip Adduction

Muscles worked:

Gluteus Medius; Adductor Longus

Position:

Stand—facing left or right

Accessory:

Hand Grip on Ankle (see Page 4)

Pulleys:

Squat Pulley Frame—Standard Pulleys

Leg Extension:

Removed

Success Tips

- Attach the Hand Grip to the Cables farthest from the active ankle.
- Do not cross the attached leg in front of the stabilized leg.
- Keep abs tight and do not lift your hips or excessively arch your back.
- Keep your spine straight and your hips level—do not raise hips during motion.
- Use only a small range of motion.

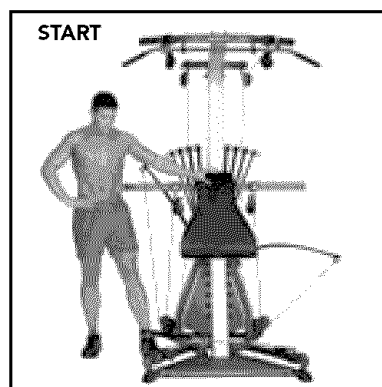

START

- Secure Hand Grip/Ankle Cuff over the ankle closest to the Power Rods®. Keep leg straightened, but knee loose.
- Adjust your position so that there is some tension in the cables at the start of this exercise.
- You may use your hand on the Seat Back Pad or Center Cross Bar to stabilize movement

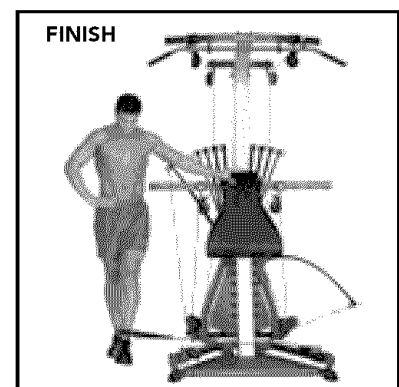

ACTION

- Slowly allow the attached leg to move inward, toward the support leg (30–45°) as you face forward, keeping your hips and spine perfectly still.
- Keeping the leg still, slowly move it back into the start position.

Leg Kickback—Hip and Knee Extension

Muscles worked:

Piriformus; Gluteus Maximus

Position:

Standing—facing Power Rods®

Accessory:

Hand Grip on Arch of Foot (see Page 4)

Pulleys:

Squat Pulley Frame—Standard Pulleys

Leg Extension:

Removed

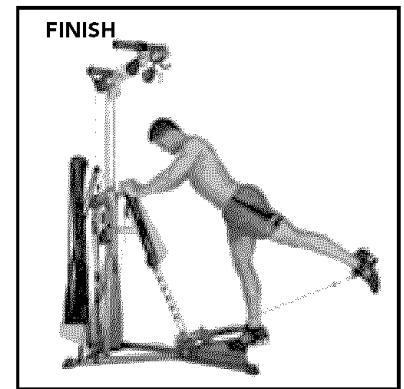
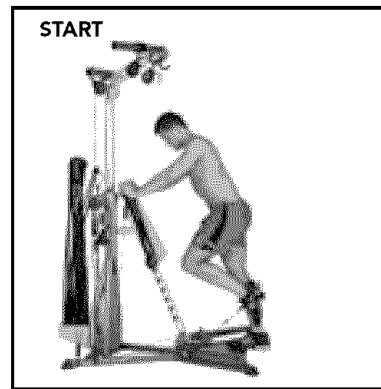

START

- Secure a Hand Grip to the arch of one foot. Keep this leg bent approximately 90°.
- Stand far enough from the Power Rods® that there is tension in the cable at the start of the exercise.
- Do not lock your supporting knee.
- Hold onto the Seat Back Pad or Center Cross Bar for added stability.

ACTION

- Slowly push the attached leg outward, away from the Power Rods®, straightening the knee, but keeping your hips and spine perfectly still.
- Slowly move it back into the start position.

Success Tips

- Lift your chest, keep your knees slightly bent and support foot on Standing Platform.
- Keep your spine straight and your hips level—do not raise your hips during motion.
- Use only a small range of motion.
- Keep your hips motionless throughout this exercise.

Hip Flexion—Knee Flexion

Muscles worked:

Iliopsoas; Rectus Femoris

Position:

Standing—facing right or left

Accessory:

Hand Grip on Ankle (see Page 4)

Pulleys:

Squat Pulley Frame—Standard Pulleys

Leg Extension:

Removed

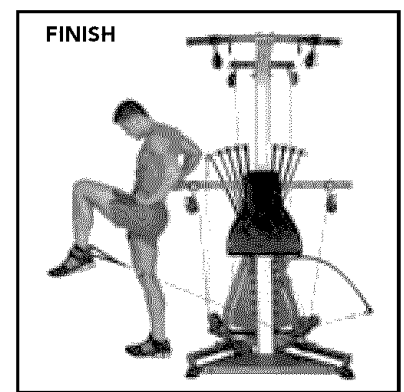
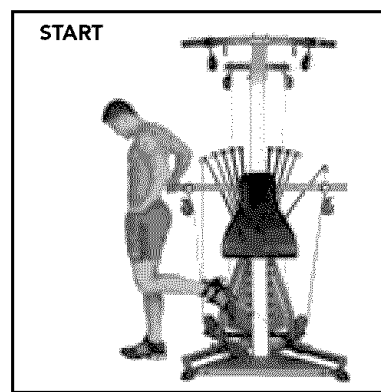

START

- Secure a Hand Grip around the ankle furthest from the Power Rods®.
- Bend forward 30-40° from your hips (not your waist) and very slightly bend the knee of your supporting leg.

ACTION

- Initiate the movement by lifting your knee up and in, toward your torso.
- Slowly move your leg as far as you can, without allowing any movement at the waist, knee or lower back.
- Slowly return to the start position without relaxing your leg muscles.

Success Tips

- Attach the Hand Grip to the Cables farthest from the active ankle.
- Keep your chest lifted, spine aligned, abs tight and a very slight arch in your lower back.
- Do not bend from waist or lower back.
- Allow active leg to hang in the direction of the cable throughout movement.

Dead Lift

Muscles worked:

Gluteus Maximus

Position:

Standing—facing outward

Accessory:

Squat Bar

Pulleys:

Squat Pulley Frame—Standard Pulleys

Leg Extension:

Removed

Success Tips

- Keep your knees slightly bent and feet on Standing Platform.
- Keep your chest lifted, spine aligned, abs tight and your back flat with no arch.
- Lift with your legs, not lower back or arms.
- Keep your abs tight throughout movement.
- Keep your knees bent and your head up.

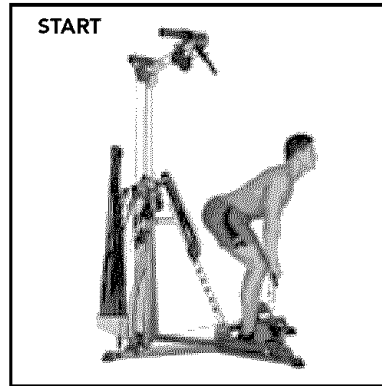

START

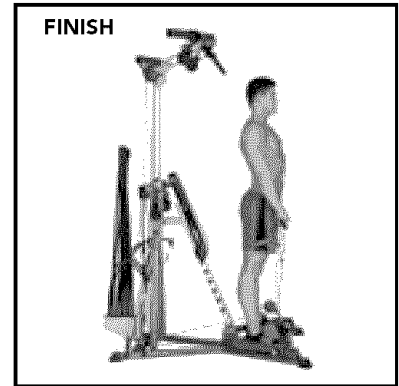

FINISH

START

- Grasp the Squat Bar with one hand in an overhand grip and the other in an underhand grip.
- Bend legs approximately 90°.
- Bend over, approximately 30-45° from your hips (not your waist)

ACTION

- Initiate the movement by pushing up with your legs.
- Slowly move upward until you are in the standing position.
- Slowly return to the start position without relaxing tension in your legs.

Stiff Leg Dead Lift

Muscles worked:

Gluteus Maximus

Position:

Standing—facing outward

Accessory:

Squat Bar

Pulleys:

Squat Pulley Frame—Standard Pulley

Leg Extension:

Removed

Success Tips

- Keep your knees slightly bent and feet on Standing Platform.
- Keep your chest lifted, spine aligned, abs tight and your back flat with no arch.
- Lift with your legs, not lower back or arms.
- Use a light resistance for this movement.
- Keep your knees bent and your head up.

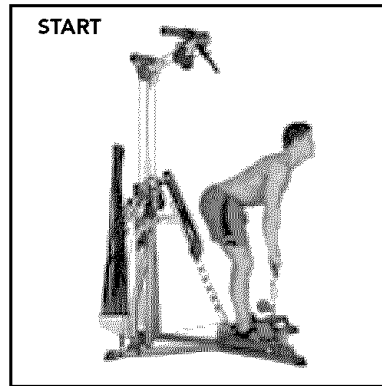

START

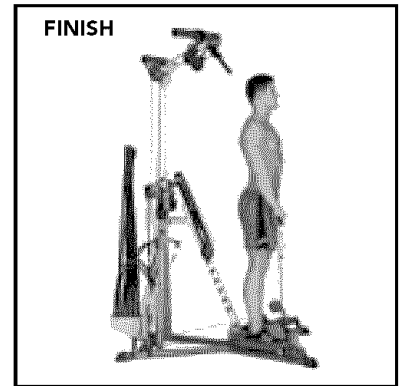

FINISH

START

- Grasp the Squat Bar with your palms facing downward.
- Keep your legs bent slightly.
- Bend over, approximately 90° from your hips (not your waist)

ACTION

- Initiate the movement by pushing your hips forward.
- Slowly move your trunk until you are in the standing position. Glutes should be tightened when reaching upright position
- Slowly return to the start position without relaxing tension in your legs.

Fast Fat Loss

NOW!

**THE BOWFLEX® XTREME²™
HOME GYM
BODY LEANNESS
PROGRAM**

By Ellington Darden, Ph.D.

The following dietary program was created for use with your Bowflex® Xtreme²™ home gym by Dr. Ellington Darden. Please consult your physician or health care professional before beginning any fitness or dietary program.

Introduction to The Bowflex® Xtreme²™ Home Gym's Body Leanness Program

This program is scientifically designed for maximum fat loss over six weeks. It is important that you practice every aspect of the plan to achieve optimum results.

The program separates into three two-week stages. During each stage you will exercise, control the number and quality of calories you consume, and drink plenty of ice-cold water.

Before starting the exercise routine, you must be familiar with your Bowflex® Xtreme²™ home gym. You should experiment with finding the proper amount of resistance and speed to use during your workouts to remain in your target fat-burning heart-rate zone.

Body Leanness Program



WARNING

Before beginning this program, consult your physician or health care professional and show them this plan.

Only your physician or health care professional can determine if this course is appropriate for your particular age and condition.

If you choose to use this program, you assume all risks, known and unknown, inherent to exercise and workout programs, diet programs, and physical changes or injuries that may result from the use of such programs.

You agree to hold Nautilus free from any and all liability resulting from the program. In addition, if you have not already done so, we suggest having a physician or health care professional review the warning for additional contraindications.

If you experience any lightheadedness, dizziness, or shortness of breath while exercising, stop the movement and consult a physician or health care

professional.

Make sure you read your Bowflex® Xtreme²™ home gym Owner's Manual before attempting a workout.

There are a few people who should not try this program: children and teenagers; pregnant women; women who are breast feeding; diabetics; individuals with certain types of heart, liver, or kidney disease; and those suffering from certain types of arthritis. This list is not all-inclusive. Some people should follow the course only with their physician or health care professional's specific guidance.

Play it safe and always consult a physician or health care professional.

Eating Guidelines

You will be following a reduced-calorie nutrition program which is divided into three two-week segments. The program is a proven method for achieving maximum fat loss over a six-week period. It consists of a carbohydrate-rich, descending-calorie eating plan and a superhydration routine.

Follow a Carbohydrate-Rich, Descending-Calorie Eating Plan:

Approximately 60 percent of your daily calories should be from carbohydrates. The other 40 percent will be equally divided between proteins and fats. The 60:20:20 ratio of carbohydrates, proteins, and fats is ideal for maximum fat loss.

Daily Amount	For Example		
	Carbohydrate 60%	Protein 20%	Fat 20%
Calories			
2000	1200	400	400
1900	1140	380	380
1800	1080	360	360
1700	1020	340	340
1600	960	320	320
1500	900	300	300
1400	840	280	280
1300	780	260	260
1200	720	240	240
1100	660	220	220
1000	600	200	200

Keep Menus Simple and Food Substitutions to a Minimum:

Research has established that successful dieters prefer the same foods each day for breakfast and lunch. They like variety, however, for dinner. Detailed menus and food choices are included later in this manual.

If you must vary from the menu items, try to stay within the 60:20:20 ratio of carbohydrates, proteins and fats.

Superhydrate Your System

Drinking plenty of water is essential to the success of this program. Drinking the recommended amount of water can seem like a challenge at first. Stick with it. Carry a large sports bottle or similar item with you throughout the day. After several weeks, you will find that you actually thirst for more and more water, and the amounts recommended are easily reached.

Superhydration aids fat loss in a number of ways. First, the kidneys are unable to function without adequate water. When they do not work to capacity some of their load is dumped onto the liver.

This diverts the liver from its primary function, which is to metabolize stored fat into usable energy. Because it's performing the chores of the water-depleted kidneys, the liver metabolizes less fat.

Second, overeating can be averted through water intake, as water can keep the stomach feeling full and satisfied between meals.

Third, ice-cold water requires calories to warm it to core body temperature. In fact, 1 gallon of ice cold water generates 123 calories of heat energy.

You'll be drinking from 1 to 1 5/8 gallons of water each day on the following superhydration schedule:

Week 1— drink 4.0 32-oz. bottles of ice-cold water per day.

Week 2— drink 4.5 32-oz. bottles of ice-cold water per day.

Week 3— drink 5.0 32-oz. bottles of ice-cold water per day.

Week 4— drink 5.5 32-oz. bottles of ice-cold water per day.

Week 5— drink 6.0 32-oz. bottles of ice-cold water per day.

Week 6— drink 6.5 32-oz. bottles of ice-cold water per day.

Don't be surprised if you have to make more than a dozen trips to the restroom, especially during the first week of the program. Remember, your body is an adaptive system and it will soon accommodate the increased water consumption.



NOTE: Although it is doubtful that you could ever drink too much water, a few ailments can be negatively affected by large amounts of fluid. For example, anyone with a kidney disorder or anyone who takes diuretics, should consult a physician or health care professional before going on the recommended water-drinking schedule. If you have any doubts about the recommendations, play it safe and check with your physician or health care professional.

The Eating Plan

The menus in the Bowflex® Xtreme²™ home gym eating plan are designed for maximum fat-loss effectiveness and nutritional value. For best results, follow them exactly.

Every attempt has been made to utilize current popular brand names and accurate calorie counts, which are listed in the menus. But, as you probably realize, products are sometimes changed or discontinued. If a listed item is not available in your area, you'll need to substitute a similar product. Become an informed label-reader at your supermarket. Ask questions about any products you don't understand. Supermarket managers are usually helpful. If they don't have an answer to your question, they will get it for you.

Each day you will choose a limited selection of foods for breakfast and lunch. Most people can consume the same basic breakfast and lunch for months with little modification. Variety during your evening meal, however, will make daily eating interesting and enjoyable. Additionally, the eating plan includes a mid-afternoon and late-night snack to keep your energy high and your hunger low.

Begin Week 1 on Monday and continue through Sunday. Week 2 is a repeat of Week 1.

The following is the eating plan for the next six weeks (calories for each food are in parentheses), with a *Shopping List* on *Page 60*.

Week 1 & 2:

Men—1500 calories per day.

Women—1200 calories per day.

Week 3 & 4:

Men—1400 calories per day.

Women—1100 calories per day.

Week 5 & 6:

Men—1300 calories per day.

Women—1000 calories per day.

You'll always have a 300-calorie breakfast, a 300-calorie lunch, and a 300-calorie dinner (women), or 500-calorie dinner (men). With each two-week descend, only your snack calories will change: from 400 to 300 to 200 calories per day (men), or 300 to 200 to 100 calories per day (women). For each of your five daily meals, you'll have at least three choices.

Everything has been simplified so even the most kitchen-challenged man or woman can succeed. Very little cooking is required. All you need to do is read the menus, select your food choices, and follow the directions. It's as simple as that.

If you find that you wish to vary from the outlined menu items, try to stay within the 60:20:20 ratio of carbohydrates, proteins, and fats.

Breakfast = 300 calories.

Choice of bagel, cereal or shake:

Bagel

1 plain bagel, Sarah Lee™ (frozen) (210)
3/4 ounce light cream cheese (45)
1/2 cup orange juice, fresh or frozen (55)
Noncaloric beverage: any beverage without calories, caffeine or sodium, such as decaffeinated coffee or tea.

Cereal

1.5 ounces (42 grams) serving equals approximately 165 calories.
Choice of one: Kellogg's™ Low Fat Granola, General Mills™ Honey Nut Clusters or General Mills™ Basic 4
1/2 cup skim milk (45)
3/4 cup orange juice (82)
Noncaloric beverage

Shake (choice of one):

Banana–Orange

1 large banana (8 3/4 inches long) (100)
1/2 cup orange juice (55)
1/2 cup skim milk (45)
2 tablespoons wheat germ (66)
1 teaspoon safflower oil (42)
2 ice cubes (optional)
Place ingredients in blender. Blend until smooth.

Chocolate or Vanilla

1 packet Carnation™ Instant Breakfast, Champion™ UltraMet, or another diet shake powder that contains the appropriate calories (100)

1 cup skim milk (90)
1/2 large banana (8 3/4 inches long) (50)
1 teaspoon safflower oil (42)
1 teaspoon Carnation™ Malted Milk powder (20)
2 ice cubes (optional)
Place ingredients in blender. Blend until smooth.

Lunch = 300 calories.

Choice of one of three meals:

Sandwich

2 slices whole wheat bread (140)
2 teaspoons Promise™ Ultra Vegetable Oil Spread (24)
2 ounces white meat (about 8 thin slices), chicken or turkey (80)
1 ounce fat-free cheese (1 1/2 slices) (50)
[Optional: Add to bread 1 teaspoon Dijon mustard (0)]
Noncaloric beverage

Soup (choice of one)

Healthy Choice™ Hearty Chicken, 15-ounce can (260), or Campbell's™ Healthy Request Hearty Vegetable Beef, 16-ounce can (260)
1/2 slice whole wheat bread (35)
Noncaloric beverage

Chef Salad

2 cups lettuce, chopped (20)
2 ounces white meat, chicken or turkey (80)
2 ounces fat-free cheese (100)
4 slices tomato, chopped (28)
1 tablespoon Italian, fat-free dressing (6)
1 slice whole wheat bread (70)
Noncaloric beverage

Mid-Afternoon Snack

Men = 200 calories for Weeks 1 & 2; 150 calories for Weeks 3&4; 100 calories for Weeks 5 & 6.

Women = 150 calories for Weeks 1 & 2; 100 calories for Weeks 3 & 4; 50 calories for Weeks 5 & 6.

1 large banana (8 3/4 inches long) (100)
1 apple (3-inch diameter) (100)
1/2 cantaloupe (5-inch diameter) (94)
5 dried prunes (100)
1 ounce (2 small 1/2 ounce boxes) raisins (82)
1 cup light, nonfat, flavored yogurt (100)

Dinner = 500 or 300 calories.

Men—500 calories, Women—300 calories

Choice of one of three meals:

Tuna Salad Dinner

In a large bowl, mix the following:

1 6-ounce can chunk light tuna in water (180)
1 tablespoon Hellmann's™ Light, Reduced-Calorie
Mayonnaise (50)
2 tablespoons sweet pickle relish (40)
1/4 cup whole kernel corn, canned, no salt added (30)
Noncaloric beverage

Men add:

1/2 cup sliced white potatoes, canned (45)
2 slices whole wheat bread (140)

Steak Dinner

3 ounces lean sirloin, broiled (176)
1/2 cup sweet peas, canned, no salt added (60)
1/2 cup beets, canned (35)
1/2 cup skim milk (45)
Noncaloric beverage

Men add:

2 slices whole wheat bread (140)
1 teaspoon Promise™ Ultra Vegetable Oil Spread (12)
1/2 cup skim milk (45)

Frozen Microwave Dinner

Choose one of five recommended meals:

Glazed Chicken Dinner, Lean Cuisine™ (230)

1/2 cup skim milk (45)
Noncaloric beverage

Men add:

2 slices whole wheat bread (140)
2 teaspoons Promise™ Ultra Vegetable Oil Spread (24)
1/2 cup skim milk (45)

Lasagna with Meat Sauce, Lean Cuisine™ (240)

1/2 cup skim milk (45)
Noncaloric beverage

Men add:

2 slices whole—wheat bread (140)
2 teaspoons Promise™ Ultra Vegetable Oil Spread (24)
1/2 cup skim milk (45)

Macaroni and Cheese, Weight Watchers™ (260)

1/2 cup skim milk (45)
Noncaloric beverage
Men add:
2 slices whole—wheat bread (140)
2 teaspoons Promise™ Ultra Vegetable Oil Spread (24)
1/2 cup skim milk (45)

Broccoli & Cheddar Cheese Sauce over Baked Potato, Lean Cuisine™ Lunch Express (250)

1/2 cup skim milk (45)
Noncaloric beverage
Men add:
2 slices whole-wheat bread (140)
2 teaspoons Promise™ Ultra Vegetable Oil Spread (24)
1/2 cup skim milk (45)

Country Inn Roast Turkey Classic, Healthy Choice™ (250)

1/2 cup skim milk (45)
Noncaloric beverage
Men add:
2 slices whole-wheat bread (140)
2 teaspoons Promise™ Ultra Vegetable Oil Spread (24)
1/2 cup skim milk (45)

Late-Night Snack

Men—200 calories for Weeks 1 & 2; 150 calories for Weeks 3&4; 100 calories for Weeks 5 & 6.

Women—150 calories for Weeks 1 & 2; 100 calories for Weeks 3&4; 50 calories for Weeks 5 & 6.

Mid-Afternoon Snacks on **Page 59**, plus the following:

1/2 cup low-fat frozen yogurt (100)
2 cups light, microwave popcorn (100)

Shopping List

Shopping List

Quantities for listed items will depend on your specific selections. Review your choices and adjust the shopping list accordingly. It may be helpful for you to photocopy this list each week before doing your shopping.

Staples

Orange juice, skim milk, whole-wheat bread, Promise™ Ultra Vegetable Oil Spread, Italian fat-free dressing, Dijon mustard, safflower oil, noncaloric beverages (tea, decaffeinated coffee, diet soft drinks, water).

Grains

Bagels, Sarah Lee™ (frozen)
Cereals—1.5 ounce serving equals approximately 165 calories; Kellogg's™ Low-Fat Granola (without raisins), General Mills™ Honey Nut Clusters, General Mills™ Basic 4.
Wheat germ, malted milk powder, popcorn (microwave light).

Fruits

Bananas, large (8 3/4 inches long), apples (3-inch diameter), cantaloupes (5-inch diameter), dried prunes, raisins.

Vegetables

Lettuce, tomatoes, whole kernel corn (canned no salt added), sweet peas, (canned no salt added), sliced white potatoes (canned), cut beets (canned).

Dairy

Yogurt (light nonfat), cream cheese (light), cheese (fat-free), low-fat frozen yogurt, Carnation™ Instant Breakfast packets, Champion Nutrition™ UltraMet Packets.

Meat, Poultry, Fish and Entrees

Chicken (thin sliced), turkey (thin sliced), tuna (canned in water), sirloin steak (lean).

Canned soup:

Healthy Choice™ Hearty Chicken, Campbell's™ Healthy Request Hearty Vegetable Beef.
Frozen microwave dinners or entrees: Lean Cuisine™ Glazed Chicken Dinner, Lean Cuisine™ Lasagna with Meat Sauce, Lean Cuisine™ Lunch Express Broccoli & Cheddar Cheese over Potato, Weight Watchers™ Macaroni and Cheese, Healthy Choice™ Grilled Turkey Breast.

Q & A

Q. I often get headaches when I eat only 1000 calories a day. What should I do?

A. Your headaches may be caused by going longer than three hours between meals or snacks. Try spacing your meals and snacks where there are fewer hours between them. Some people who are used to drinking regular coffee with caffeine notice headaches when they stop consuming coffee for several days. If this is the case with you, you might want to ease off the coffee more gradually.

Q. I don't like red meat. I notice that the Lean Cuisine™ Lasagna with Meat Sauce contains beef. What can I substitute for it?

A. Lean Cuisine™ has many other frozen dinners that you may substitute for Lasagna with Meat Sauce. Try to find one that contains the same calories, with approximately 15 to 20 percent of the calories coming from fat. Some of the Lean Cuisine™ dinners actually have too little fat for my nutritional requirements.

Q. May I have dinner for lunch and lunch for dinner?

A. Yes.

Q. I tend to get a headache when I drink cold water. Can I drink water without it being chilled?

A. Yes, but you won't get the 123 calories or more thermogenic effect from warming the cold water to core body temperature. Try a more gradual drinking of the cold water. You may have been consuming it too quickly.

Q. Is it possible to drink too much water?

A. Certainly. To do so, however, you'd probably have to drink four or five times as much per day as I'm recommending. There are a few ailments that can be negatively affected by large amounts of fluid. If you feel you have a problem, check with your doctor before starting the program.

Q. Is bottled water better than tap water?

A. Research shows that bottled water is not always higher quality water than tap water. The decision to drink bottled water or not is usually one of taste. If you dislike the taste of your tap water, then drink your favorite bottled water. But first you might want to try a twist of lemon or lime added to the water from your tap. Some people say it makes a significant difference in the taste.

Q. I'm a middle-aged woman who gets black and blue marks on my legs when I diet. Am I doing anything wrong?

A. I doubt you are doing anything wrong. Such black and blue marks are usually the result of an increased level of estrogen circulating in your body, which weakens the walls of the capillaries and causes them to break under the slightest pressure. When this happens, blood escapes and a bruise occurs. Estrogen is broken down in the liver, and so is fat. When you are dieting, your liver breaks down the fat, leaving a lot more estrogen in the bloodstream. It may be helpful to supplement your diet with a little extra vitamin C each day to help toughen the walls of the capillaries.

Q. I'm a 40-year-old woman with a teenage son and daughter. My husband and I both want to lose 10 pounds and the children would also like to lose some weight. Can I put the whole family on the program?

A. It would be great if you could, but you cannot. The number of calories per day is the problem. Teenagers require significantly more calories each day than 1500, which is the highest level. Check with a registered dietician (RD) for appropriate recommendations.

Q. What happens after six weeks? How do I continue the program if I need to lose more weight?

A. You should repeat the program for as long as it takes you to reach your goal. There are, however, a few guidelines and modifications to apply. Repeat the eating plan exactly as before: Men, go back to 1500 calories a day for two weeks. Women, go back to 1200 calories a day for two weeks. Then, descend your calories in the same manner. Keep your superhydration schedule at the highest level. In other words, sip 1½ gallons of ice-cold water each day.

Q. I'm pleased that I lost the fat I wanted to lose. What do I do to maintain my new body weight?

A. Once you've lost your excessive fat, your next task is to maintain that status. The following section shows the adjustments you need to make to your current practices.

Maintaining Your Lean Body

Adhere to a carbohydrate-rich, moderate-calorie eating plan.

Instead of eating from 1000 to 1500 calories a day, you'll be consuming from 1600 to 2400 calories per day. Maybe you can eat even more after your new body weight has stabilized. Trial-and-error experimentation is a must. Women should start with 1600 calories, and men with 2000 calories per day. Note what happens after a week. If your body weight keeps going down, raise the calories by 100 or 200; depending on how much weight you lost during the last week.

Soon, you should reach a level where your body weight stabilizes. That level is your daily calorie requirement. Naturally, you'll be able to consume other foods than those listed in the Bowflex® Xtreme^{2™} home gym eating plan. By then, however, you should know the value of being a smart shopper and a wise eater. Read labels. Compare nutritional information. Be conscious of the ideal 60:20:20 ratio for carbohydrates, proteins, and fats.

Eat smaller meals more frequently.

You've been limiting your five meals per day to 300 calories if you're a woman, or 500 calories if you're a man. You may now up the calories by 100. What happens if during a single meal you eat more than 400 calories if you're a woman, or 600 calories if you're a man? Don't panic. Simply understand that you will sometimes backslide. Learn to anticipate these urges and take corrective action.

Drink at least 1 gallon of cold water each day.

You should realize by now the benefits of consuming plenty of water each day. Make your water bottle a permanent part of your lifestyle.

Bowflex® Xtreme²™ Home Gym 6-Week Satisfaction Guarantee

We want you to know that the Bowflex® Xtreme²™ home gym is a superior product. Your satisfaction is guaranteed.

If, for any reason, you are not 100% satisfied with your Bowflex® Xtreme²™ home gym, please follow the instructions below to return your merchandise and receive a refund of the purchase price, less shipping and handling.

1. Call a Nautilus Representative at 1-800-269-3539 for a Return Authorization Number. Return Authorization will be granted if:
 - a. You purchased your Bowflex® Xtreme²™ home gym directly from Nautilus, and
 - b. You are calling within 6 weeks of the delivery date of your merchandise.

Returns should be shipped to: 1400 NE 136th Ave., Vancouver, WA 98684.

2. All returned merchandise must be properly packaged in the original boxes and in good condition.

NOTE: You are responsible for return shipping and for any damage or loss to merchandise that occurs during return shipment. We highly recommend that you insure your shipment.

3. Please mark all boxes clearly with:

- Return Authorization Number
- Your Name
- Your Address
- Your Phone Number

Boxes without this information clearly marked on the outside may be refused.

4. Please make copies of your original invoice and put one in each box of merchandise. Nautilus must receive your shipment within two weeks from the date the Nautilus Representative issued you your Return Authorization Number.

Refunds may be denied or delayed if these instructions are not completely followed.

This Bowflex Satisfaction Guarantee applies only to merchandise purchased by consumers directly from Nautilus Health and Fitness Group. This guarantee does not apply to sales made by dealers or distributors.

Bowflex Xtreme², Bowflex and the Bowflex logo are trademarks of Nautilus, Inc.
© 2004, The Nautilus Group, Inc. 1400 N.E. 136th Ave., Vancouver, WA 98684.

Bowflex® Xtreme²™ Home Gym Warranty Registration Card

IMPORTANT! MAIL WITHIN 30 DAYS OF PURCHASE

PLEASE PRINT CLEARLY – THANK YOU

Mr. 2. Mrs. 3. Ms. 4. Miss Customer ID from Invoice

Name:

Address: Apt #:

City: State: Zip:

Phone number: () - X

E-Mail address:

Is this your primary address? Yes No

Place of purchase:

Date of purchase:
M M D D Y Y

Purchaser date of birth:
M M D D Y Y

Gender: Male Female

Marital status: Married Single

Including yourself, total number of people living in your household: (Examples: 01, 02, 03 ...)

Would you like to receive additional information on healthy lifestyle products? Yes No

Which best describes your family income:

- Under \$15,000 \$25,000 – \$34,999 \$50,000 – \$74,999 \$100,000 – \$149,999
 \$15,000 – \$24,999 \$35,000 – \$49,999 \$75,000 – \$99,999 Over \$150,000

What other types of exercise equipment do you own?

Did you receive this item as a gift? Yes No

Name of original purchaser:

Original purchaser customer ID number:

Thanks for filling out this questionnaire. Your answers are important to us. Please check here if you would prefer not to obtain information on new and interesting opportunities from other exciting companies.

What Is Covered

Nautilus warrants to the original purchaser of the Bowflex® Xtreme^{2™} home gym that the Bowflex® Xtreme^{2™} home gym is free from defects in materials or workmanship, with the exceptions stated below. This warranty is not transferable or applicable to any person other than the original purchaser and is only applicable for products sold and used in the United States or Canada. Tampering with the unit will void the warranty.

Bowflex¹ Xtreme^{2™} Home Gym

- 7 years on machine
- No-Time-Limit Warranty on Power Rods

Warranties Do Not Cover

- A Bowflex® Xtreme^{2™} home gym purchased for commercial or institutional use.
- Damage due to use by persons who weigh more than 300 pounds.
- Damage due to abuse, accident, failure to follow instructions or warnings in the Owner's Manual, misuse, mishandling, accident or Acts of God (such as floods or power surges).
- Damage due to normal wear and tear.

What Nautilus Will Do

During your Warranty Coverage Period, Nautilus will repair any Bowflex® Xtreme^{2™} home gym that proves to be defective in materials or workmanship. In the event repair is not possible, Nautilus will either replace your Bowflex® Xtreme^{2™} home gym or refund your purchase price, less shipping and handling.

Service Support

Call to speak with a Nautilus Representative at 1-800-269-3539. You may need to return the defective part, at your expense, to the address given you by the Nautilus Representative. Always include an explanation of the problem. Adequate protective packaging of the defective parts or unit and cost of shipping are your responsibility.

The repaired part or unit will be returned to you at the company's expense.

How State Law Applies

This warranty gives you specific legal rights, and you may also have other rights which vary from state to state.



Please fold over and tape before mailing



Please fold over and tape before mailing

Place
Stamp
Here

BOWFLEX XTREME²
1400 N.E. 136th Ave.
Vancouver, WA 98684

Warranty Information

(Keep For Your Records)

What Does This Warranty Cover?

Nautilus warrants to the original purchaser of the Bowflex® Xtreme^{2™} home gym that the Bowflex® Xtreme^{2™} home gym is free from defects in materials and workmanship, when used for the purpose intended, under normal conditions. This Warranty is extended only to the original purchaser, and is not transferable to any other person.

How Long Does Warranty Coverage Last?

Residential

- 7 Years on machine
- No-Time-Limit Warranty on Power Rods

Commercial

- This warranty is void if the Bowflex® Xtreme^{2™} home gym is used in a Commercial Environment.

This warranty covers all defects in material or workmanship of the Bowflex® Xtreme^{2™} home gym. Warranties do not cover commercial or institutional use or misuse and abuse by the consumer.

To make this warranty effective, you must completely fill out the Bowflex® Xtreme^{2™} home gym Warranty Registration Card within 30 days of purchase, and return it to the address on the Warranty Registration Card.

Warranty Does Not Cover:

- A Bowflex® Xtreme^{2™} home gym purchased for commercial or institutional use.
- Damage due to use by persons who weigh more than 300 pounds.
- Damage due to abuse, accident, failure to follow instructions or warnings in the Owner's Manual, misuse, mishandling, accident or Acts of God (such as floods, tornadoes, power surges, etc.).
- Damage due to normal wear and tear.

What Nautilus Will Do.

During your Warranty Coverage Period, Nautilus will repair any Bowflex Xtreme² that proves to be defective in materials or workmanship. In the event repair is not possible, The Nautilus Group, Inc., will either replace your Bowflex or refund your purchase price, less shipping and handling.

Nautilus reserves the right to substitute material of equal or better quality if identical materials are not available at the time of service under this Warranty. The replacement of the product under the terms of the Warranty in no way extends the Warranty period.

Service Support

Call to speak with a Nautilus Representative at 1-800-269-3539. You may need to return the defective part, at your expense, to the address given you by the Nautilus Representative. Always include an explanation of the problem with service shipments. Adequate protective packaging of the defective parts or unit and cost of shipping to the above address are your responsibility.

The repaired part or unit will be returned to you at the company's expense.

How State Law Applies.

This warranty gives you specific legal rights, and you may also have other rights, which vary from state to state.

Exercise Log

Please feel free to make copies of this chart to continue your exercise log.

EXERCISE	DATE	2/15	DATE	DATE	DATE	DATE	DATE
<i>Bench Press</i>	Sets	2					
	Reps	10, 9					
	Resistance	120, 130					
	Sets						
	Reps						
	Resistance						
	Sets						
	Reps						
	Resistance						
	Sets						
	Reps						
	Resistance						
	Sets						
	Reps						
	Resistance						
	Sets						
	Reps						
	Resistance						
	Sets						
	Reps						
	Resistance						
	Sets						
	Reps						
	Resistance						
	Sets						
	Reps						
	Resistance						
	Sets						
	Reps						
	Resistance						
	Sets						
	Reps						
	Resistance						

Muscle Chart

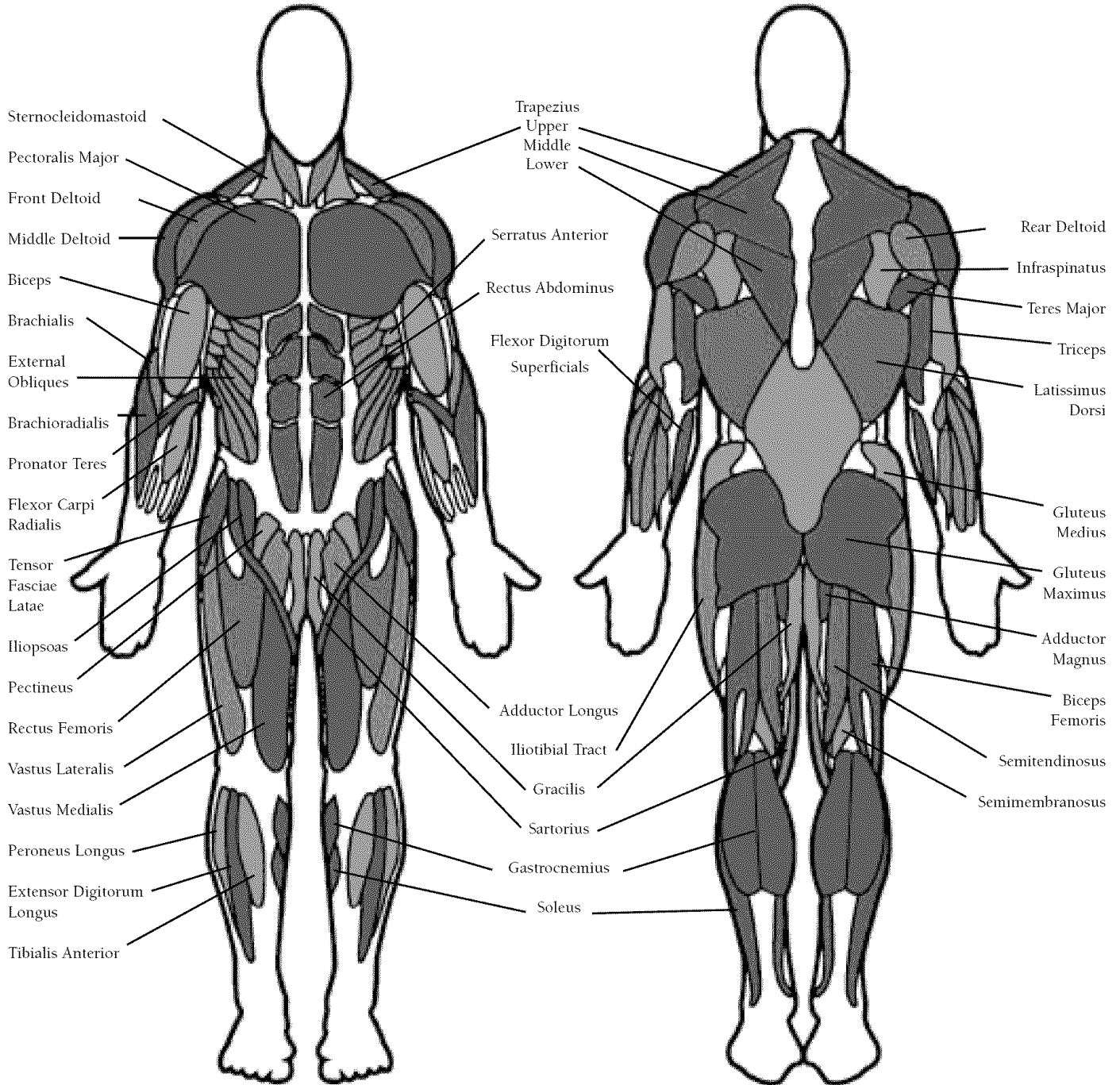

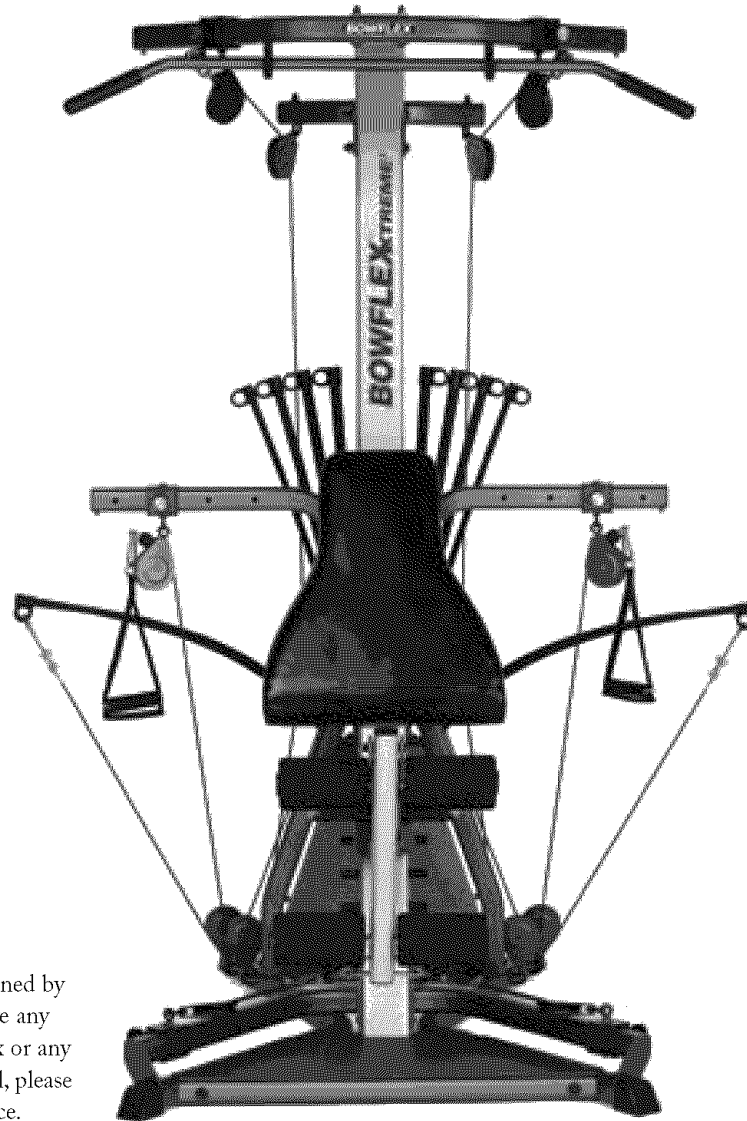
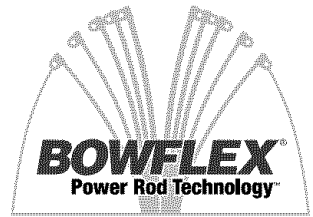

This manual is written and designed by industry professionals. If you have any questions regarding your Bowflex or any instructions found in this manual, please call 1-800-269-3539 for assistance.

BOWFLEX[®] XTREME²