

A thick black vertical bar is positioned to the left of the title text.

# **mBSC DAS SYSTEM INSTALLATION AND OPERATIONS MANUAL**

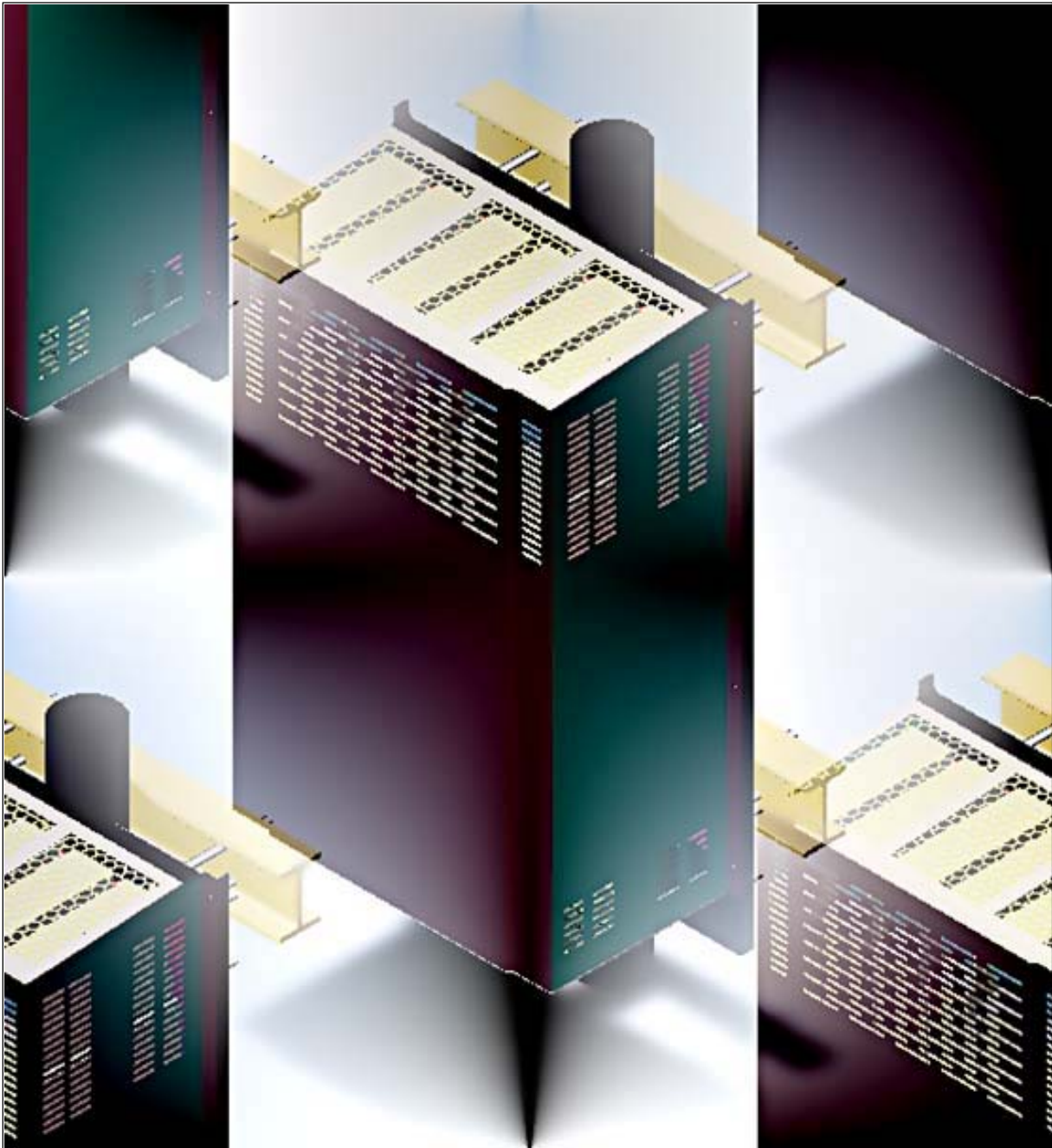

## **COPYRIGHT**

This document serves as the System Installation Manual for the BTI mBSC Fiber Distributed Antenna System (DAS) system. BTI reserves the right to change the contents without prior notice. No part of this document may be reproduced or utilized. © 2009-2011, BTI, All Rights Reserved

## **REVISION HISTORY**



<b>ISSUE NO.</b>	<b>DESCRIPTION</b>	<b>DATE</b>
1	INITIAL DRAFT	OCT. 28, 2009
2	UPDATE THE SPECIFICATION	JAN. 18, 2010
3	UPDATE SPECIFICATION, INSTALLATION, AND ILLUSTRATIONS	MAY 31, 2011

# TABLE OF CONTENTS

<b>1</b>	<b>GENERAL INFORMATION .....</b>	<b>6</b>
1.1	<i>SAFETY PRECAUTIONS .....</i>	<i>6</i>
1.2	<i>GLOSSARY AND ACRONYMS .....</i>	<i>7</i>
<b>2</b>	<b>INTRODUCTION .....</b>	<b>8</b>
<b>3</b>	<b>GENERAL DESCRIPTION.....</b>	<b>8</b>
3.1	<i>SYSTEM COMPONENTS DESCRIPTION .....</i>	<i>8</i>
3.1.1	Host Unit .....	9
3.1.2	Network Management System.....	9
3.1.3	Remote Unit .....	10
3.2	<i>USER INTERFACE .....</i>	<i>13</i>
3.2.1	Host Unit Interface .....	13
3.2.2	NMS Interface .....	13
3.2.3	Remote Unit Interface .....	15
3.3	<i>SPECIFICATIONS .....</i>	<i>17</i>
3.3.1	Host Unit Specifications .....	17
3.3.2	NMS Specifications .....	17
3.3.3	Remote Unit Specification .....	18
<b>4</b>	<b>INSTALLATION .....</b>	<b>19</b>
4.1	<i>SYSTEM INSTALLATION OVERVIEW.....</i>	<i>19</i>
4.2	<i>REMOTE UNIT INSTALLATION .....</i>	<i>20</i>
4.2.1	Remote Unit Installation Overview.....	20
4.2.2	Installation Hardware And Tools .....	20
4.2.3	Unpacking And Inspection .....	22
4.2.4	<b>Mechanical Installation .....</b>	<b>23</b>
4.2.4.1	Mechanical Safety Precautions.....	23
4.2.4.2	Install The Mounting Panel.....	24
4.2.4.3	Install The Remote Unit On The Mounting Panel .....	25
4.2.4.4	Install The Shroud Cover .....	25
4.2.5	<b>Electrical Installation.....</b>	<b>27</b>
4.2.5.1	Electrical Safety Precautions .....	27
4.2.5.2	Grounding .....	28
4.2.5.3	Route the Cables .....	28
4.2.5.4	Fiber Optic Cable Connection.....	28
4.2.5.5	Antenna Cable Connection .....	29
4.2.5.6	AC Power Cable Connection .....	30
4.2.5.7	Slave Cable Connection .....	31
4.2.6	<b>Remote Unit Installation Review .....</b>	<b>33</b>

4.2.6.1 Mechanical Installation Review .....	33
4.2.6.2 Electrical Installation Review.....	33
4.2.6.3 Field Status Test - Remote Unit LED Status Indicators.....	33
<b>4.2.7 Troubleshooting .....</b>	<b>34</b>
<b>4.3 HOST UNIT INSTALLATION .....</b>	<b>35</b>
<b>4.3.1 Host Unit Installation Overview .....</b>	<b>35</b>
<b>4.3.2 Installation Hardware And Tools .....</b>	<b>35</b>
<b>4.3.3 Unpacking And Inspection .....</b>	<b>36</b>
<b>4.3.4 Electrical Installation.....</b>	<b>37</b>
4.3.4.1 Electrical Safety Precautions .....	37
4.3.4.2 Grounding .....	38
4.3.4.3 DC Power Cable Connection .....	39
4.3.4.4 Install the BIU and FIU modules .....	40
4.3.4.5 Alarm Installation.....	40
4.3.4.6 Connect the BIU/FIU Modules .....	42
4.3.4.7 Optional Equipment Installation .....	43
4.3.4.8 Connect POI to BIU.....	44
4.3.4.9 Connect the Fiber Optic Cable.....	44
<b>4.3.5 Host Unit Installation Review .....</b>	<b>44</b>
4.3.5.1 Electrical Installation Review.....	44
<b>4.3.6 Troubleshooting .....</b>	<b>46</b>
<b>4.4 NMS INSTALLATION.....</b>	<b>47</b>
<b>4.4.1 Installation Overview.....</b>	<b>47</b>
<b>4.4.2 Installation Hardware and Tools.....</b>	<b>47</b>
<b>4.4.3 Unpacking And Inspection .....</b>	<b>48</b>
<b>4.4.4 Verify Server software.....</b>	<b>48</b>
<b>4.4.5 Initial System Setup .....</b>	<b>49</b>
4.4.5.1 CD-ROM Install.....	49
4.4.5.2 Launch NMS .....	51
<b>4.4.6 Initial Start-up Configuration.....</b>	<b>52</b>
4.4.6.1 Modify Default Accounts.....	54
4.4.6.2 Set-up New User Accounts .....	57
4.4.6.3 Configure Software Parameters.....	59
<b>4.4.7 Firmware Update .....</b>	<b>60</b>
<b>4.4.8 Software Upgrade Installation.....</b>	<b>61</b>
4.4.8.1 CD-ROM Install .....	61
<b>4.4.9 NMS Upgrade Installation Review .....</b>	<b>62</b>
<b>4.4.10 Troubleshooting .....</b>	<b>64</b>
<b>5 mBSC DAS SYSTEM START-UP .....</b>	<b>65</b>
<b>5.1 SYSTEM COMMUNICATION.....</b>	<b>65</b>
5.1.1 Establishing a Host Unit communication.....	65
<b>5.2 INITIAL NETWORK CONFIGURATION .....</b>	<b>68</b>

<b>5.2.1 Add a Site</b> .....	<b>70</b>
<b>5.2.2 Add a Host Unit</b> .....	<b>72</b>
<b>5.2.3 Configuring the Host Unit Hardware Card</b> .....	<b>74</b>
<b>5.2.4 Map the IP Address to the NMS Software</b> .....	<b>78</b>
<b>5.2.5 Add a Master Remote</b> .....	<b>80</b>
<b>5.2.6 Add a Slave Remote</b> .....	<b>81</b>
<b>5.2.7 Connect Host Unit to Server</b> .....	<b>82</b>
<b>5.3 <i>MANAGING AND MONITORING ALARMS</i></b> .....	<b>83</b>
<b>5.3.1 Alarm Manager</b> .....	<b>83</b>
<b>5.3.2 Configuring Standard Alarm Defaults</b> .....	<b>84</b>
<b>5.3.3 System Activation Review</b> .....	<b>89</b>
<b>5.3.4 Troubleshooting</b> .....	<b>90</b>
<b>6 CUSTOMER SERVICE CONTACT INFORMATION</b> .....	<b>91</b>

# 1 GENERAL INFORMATION

## 1.1 SAFETY PRECAUTIONS



**Danger:** Danger is used to indicate the presence of a hazard that will cause serious personal injury, death or substantial property damage if the hazard is not avoided.



**Warning:** Warning is used to indicate the presence of a hazard that may cause serious personal injury, possible death or substantial property damage if the hazard is not avoided.



**Caution:** Caution is used to indicate the presence of a hazard that will or may cause minor personal injury or substantial property damage if the hazard is not avoided.

1. For general safety, only appropriately qualified personnel familiar with all recommended and regulatory safety practices and installation methods may be allowed to work on this system.
2. All general and regional safety and installation regulations relating to high voltage installations, proper use of tools and recommended individual protective equipment must be obeyed.
3. Operating instructions must be kept accessible and available for all users.
4. The network provider is responsible for implementing protective measures to avoid the health hazards associated with radiation from the Unit antenna(s).
5. For US and Canadian installations: FCC RF exposure compliance requires the following antenna installation and device operation configurations be satisfied: A separation distance of **at least 4 meters** must be maintained between the antenna of this device and all persons. RF exposure compliance may need to be addressed at the time of licensing, as required by the responsible FCC Bureau(s), including antenna co-location requirements of 1.1307(b)(3). § 2.1091 Maximum permissible antenna gain is **16.15 dBi**.
6. Access should be restricted to appropriately qualified personnel.
7. Operation of this Unit is restricted to the license holders of the respective frequency range.
8. Use of this equipment is only for the purpose specified by the manufacturer. Modifications or the use of any spare parts which are not provided by or recommended by the manufacturer are prohibited as this may cause fires, electric shock or other injuries or damage.
9. High temperatures due to power dissipation may occur, do not operate the equipment on or near combustible materials.
10. Ascertain that the mains supply is disconnected before opening the Unit as well as connecting or disconnecting the mains connector at the Remote Unit.
11. Observe ESD precautions. Use the available grounding system to connect ESD protection measures before commencing maintenance work.
12. This Unit complies with European standard EN60950.
13. Verify that all regulatory requirements have been met and that all system settings have been set according to the intended use. (Please see appropriate manufacturer product information materials.)
14. Grounding the antenna cables close to the antenna connectors of the Remote Unit for

protection against atmospheric discharge is highly suggested, even though the Remote Unit is internally protected against over-voltage.



**15. Class 1 – Laser Radiation warning: Do not look into the beam, view it directly, or indirectly with or without optical instruments.**

## 1.2 GLOSSARY AND ACRONYMS

The acronyms and abbreviations used in this manual are detailed in the following list.

<b>Abbreviation</b>	<b>Description</b>
AISG	Antenna Interface Standard Group
BIU	Base station Interface Unit
BTS	Base Station
CFR	Crest Factor Reduction
CL-OS	Closed-Loop Operating System
DAS	Distributed Antenna System
EDGE	Enhanced Data for GSM Evolution
FIU	Fiber Interface Unit
FIU-S	Fiber Interface Unit - Simulcast
FIU-NS	Fiber Interface Unit - Non-Simulcast
HPA	High Power Amplifier
HU	Host Unit
LMU	Location Measurement Unit
LNA	Low Noise Amplifier
mBSC	Multi-Band Multi-System Multi-Carriers
MIMO	Multi-input multi-output MTBF
	Mean Time Between Failure
NMS	Network Management System
PA	Power Amplifier
PCU	Power Controller Unit
PWM	Pulse Width Modulation
RCU	Remote Control Unit
RF	Radio Frequency
RU	Remote Unit
RX	Receive Signal
TDTD	Time delay TX diversity
TMA	Tower Mounted Amplifier
TX	Transmit Signal
UMTS	Universal Mobile Telecom System
VSWR	Vertical Standing Wave Ratio



## 2 INTRODUCTION

This document provides the installation procedures for the BTI DAS system consisting of the DAS Host Unit, Remote Unit equipment and the Network Management System (NMS). It also provides for the initial configuration set-up, operation procedures and the software upgrade installation process for the Network Management System.

For Host Unit and Remote Unit installation, the reader should be familiar with the use of Distributed Antenna Systems, power system distribution for both AC and DC, all safety guidelines and regulations, and the required tools to accomplish the installation in a safe manner.

**NOTE:** This equipment has been tested and found to comply with the limits for a Class A digital device, pursuant to Part 15 of the FCC Rules. These limits are designed to provide reasonable protection against harmful interference when the equipment is operated in a commercial environment. This equipment generates, uses, and can radiate radio frequency energy and, if not installed and used in accordance with the instruction manual, may cause harmful interference to radio communications. Operation of this equipment in a residential area is likely to cause harmful interference in which case the user will be required to correct the interference at his own expense.

For NMS software installation and configuration as well as firmware update and software upgrade installations, the reader should be familiar with server administration, software install, firmware update, and software upgrade procedures at the administrator level.

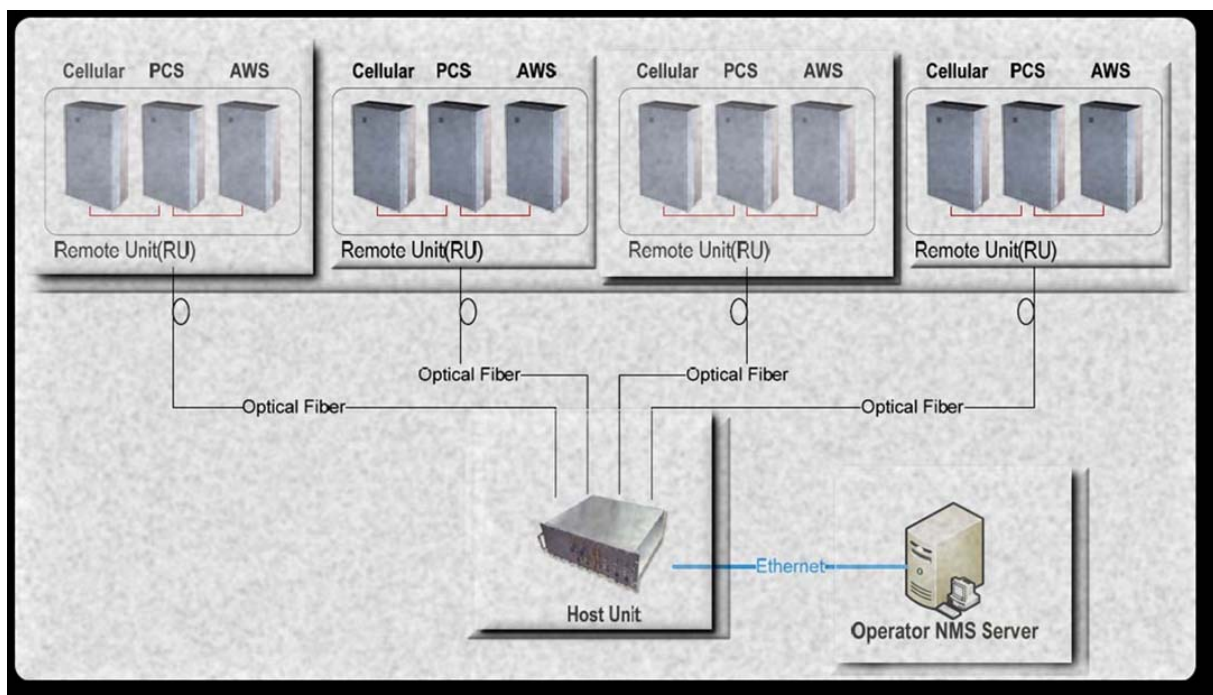

## 3 GENERAL DESCRIPTION

Figure 3-1. BTI DAS System

The system consists of an Indoor HU (Host Unit) and an Outdoor RU (Remote Unit) and Network Management Software.

### 3.1 SYSTEM COMPONENTS DESCRIPTION

The Host Unit is designed to be mounted in a 19" rack and should only be utilized in an indoor environment (0C - 45C) or in a place where an indoor-type environment can be provided.

The NMS (Network Management System) runs on a centralized server that provides access to the entire network of hub sites and Remote nodes. The NMS is designed to configure, monitor, and manage all system functionality.

The Remote Units may consist of combinations of 700MHz, 850MHz, 1900MHz and 2100MHz frequencies and are available in either a 20 Watt or 40 Watt output configuration. Each RU is designed to support a Single Frequency Band. For multi-frequency use, the system can be configured as multiple Master/Slave Remote Units. Each Master Unit can support a maximum of two slave RUs with a maximum of three RUs supported per fiber connection. The primary transport between the HU and the RU is fiber optic. The Fiber Optic also provides the RU alarms and configuration communication between the NMS and the Remote Unit. The downlink and uplink optical signals are duplexed so only one fiber is required.

### 3.1.1 Host Unit

The Host Unit provides a multiple slot assembly, consisting of 9 slots numbered from left to right: 1 through 9. Slots 7 through 9 are used and specifically keyed for the Remote Control Unit (RCU) and two redundant Power Supply Units (PSU) only. The Host Unit also houses the Base Station Interface Units (BIU) and Fiber Interface Units (FIU), **Figure 3-2**. The BIU comes in Diversity (BIU-D) and Non-Diversity (BIU-ND) and the FIU comes in Simulcast (FIU-S) and Non-Simulcast (FIU-NS) modules. The HU allows multiple combinations of BIU and FIU modules with up to 3 band downlink and uplink RF signals per BIU from the BTS and converts them to analog over RF for fiber transport.

The Host Unit, through interface combinations, provides the following functions:

- Converts the BTS RF signal to fiber signal.
- Supplies connectivity between the BTS and the Remote Unit.
- Manages and monitors the system alarms and configurations.
- Supports 1 to 3 Sectors system configurations.
- Supports a single sector with 1:1, 2:1, 3:1 and 4:1 Simulcast configuration.
- Supplies fiber connectivity to the Remote Unit with in-band message signaling.



Figure 3-2. Host Unit Multiple-Slot Assembly

### 3.1.2 Network Management System

The Network Management System (NMS), shown in **Figure 3-3**, is a software-based Network Management System tool that provides control and monitoring functions for the BTI mBSC DAS system. NMS is used to provision and configure a new system for operation, set the system operating parameters, get system alarms and status messages, and update the system firmware.

The Network Management System provides the following functions:

- Manages SNMP v2 messaging to the Network Operating Center (NOC).
- Provides a detailed graphic User Interface to manage, monitor and configure multiple DAS system.
- Configure multiple DAS systems custom alarms.
- Provides a firmware update interface.

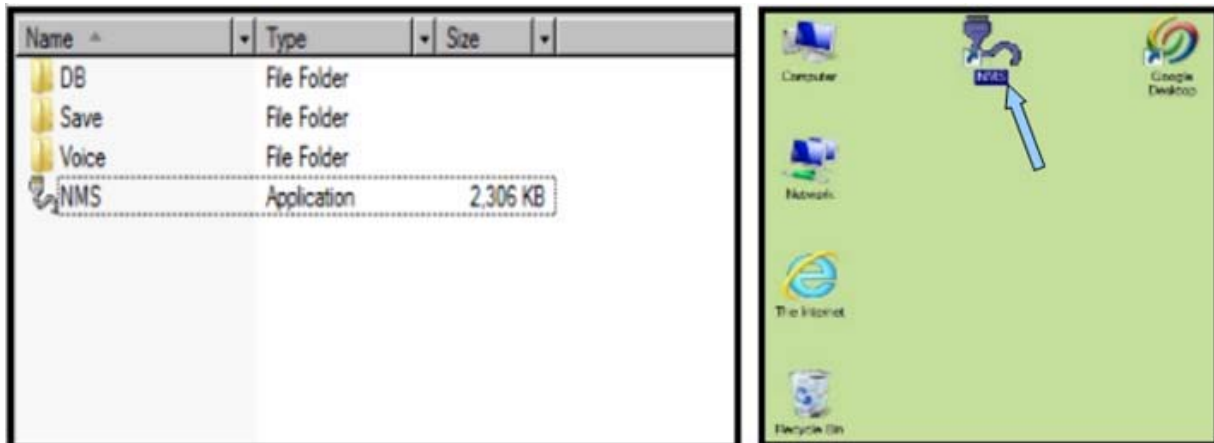

Figure 3-3. Network Management System Software Components Folder and Desktop Icon

### 3.1.3 Remote Unit

The Single-Band Master Remote Unit, shown in **Figure 3-4a, b and c**, consists of an optical module (O/E), a downlink power amplifier, an LNA, and duplexer. The Optical module converts the downlink optical signal from the FIU module in the HU and splits the RF signal into 3 RUs. It also converts the uplink RF signal to an optical signal and simultaneously sends it to the FIU module in the HU for distribution to the BIU modules. Each optical module can support 3 RUs in any combination of different bands.

The Single-Band Master Remote Unit provides the following functions:

- Converts the forward optic signal to RF signal.
- Boosts the forward RF signal from the HU to a higher power level (max output:40W).
- Amplifies the uplink signal from the antenna to improve the system receive sensitivity.
- Supplies in-band messaging between the HU and RU for RU Alarms and configuration.

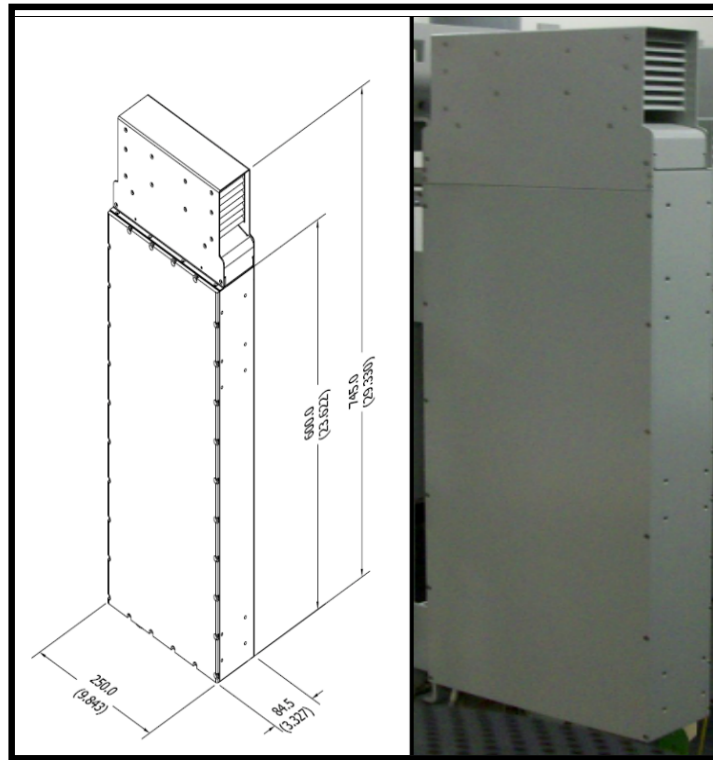

**Figure 3-4a. 40 Watt Fan Cooled Remote Unit**

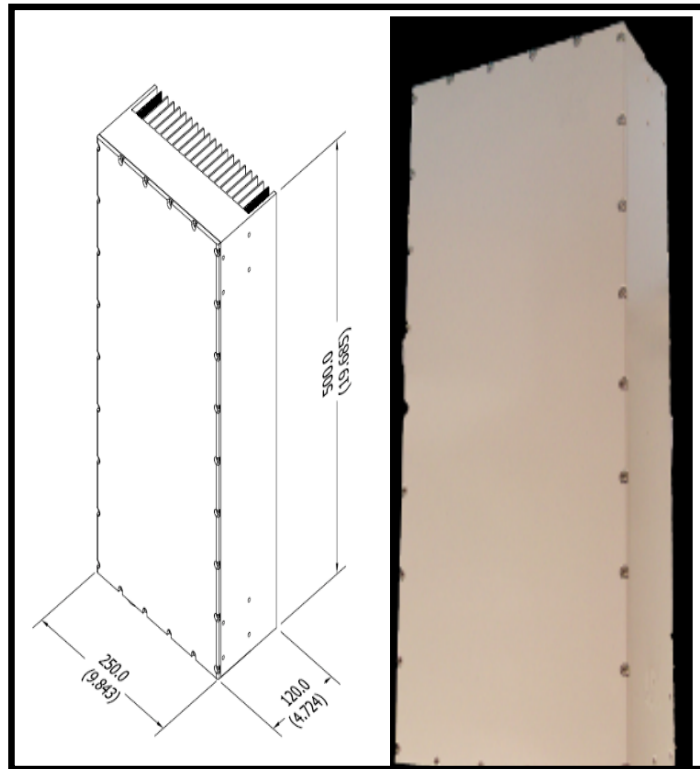

Figure 3-4b. 20 Watt Convection Cooled Remote Unit

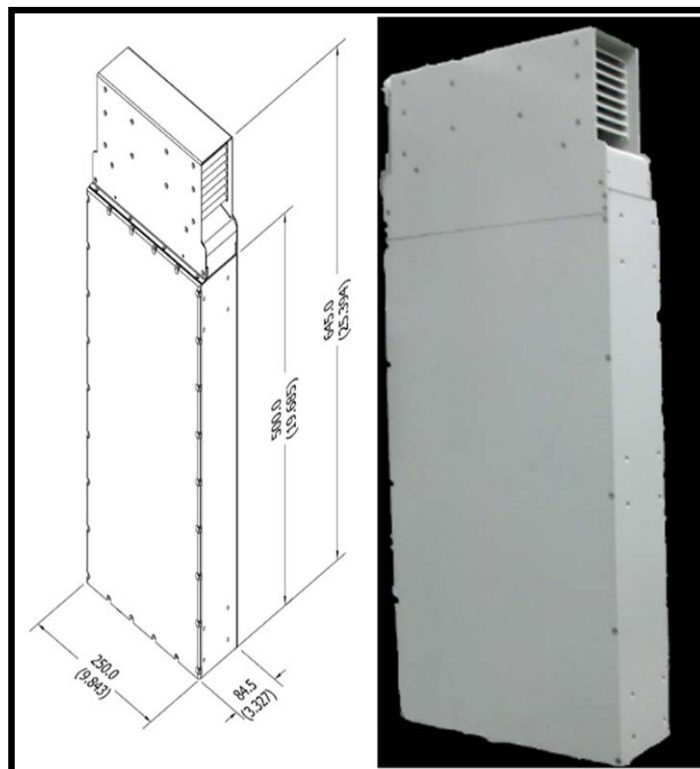

Figure 3-4c. 20 Watt Fan Cooled Remote Unit

## 3.2 USER INTERFACE

The user interface for each segment of the mBSC DAS System is designed to provide the most efficient interaction, installation and ease of use for the user.

### 3.2.1 Host Unit Interface

Each interface module of the Host Unit, shown in **Figure 3-5**, is described in **Table 3-1** below.



Figure 3-5. Host Unit Interface

Table 3-1. Host Unit User Interface

Module Name	Port Name	Description	Remark
FIU-S/FIU-NS	TX1, TX2	Downlink interface ports to be connected to BIU output	RF signal
	RX1, RX2	Uplink interface ports to be connected to BIU input	RF signal
	Fiber 1, Fiber 2	Fiber optic interface ports to be connected to the RU	Optical signal
	E9111, E9111-2	The RX coupling uplink signal for LMU (TDOA location only)	RF signal
	E9111, E9111-2	The RX coupling uplink signal for LMU (TDOA Location only)	RF signal
	E9111, E9111-2	The RX coupling uplink signal for LMU (TDOA Location only)	RF signal
BIU-ND/BIU-D	TX1, TX2, TX3, TX4	Input signals from the BTS to provide the combined downlink signal to FIUs	RF signal
	RX1, RX2, RX3, RX4	The combined uplink signal from FIUs	RF signal
	TX1 and TX2 out	Downlink RF interface to FIU	RF signal
	RX1, RX2, RX3, and RX4 out	Uplink RF interface from the FIU	RF signal

### 3.2.2 NMS Interface

A simple login access, **Figure 3-6**, allows for quick access. A graphical user interface, **Figure 3-7**, provides real time user access to the configuration, performance monitoring, and alarm status. The system also uses SNMPv2.0 protocol to transmit automated traps to the operator's Network Operations

Center for remote alarming and system queries. These two capabilities provide for centralized configuration and alarm monitoring of the entire system.

Operational parameters, such as uplink and downlink, and gain can be set through the NMS server. Status information at each node is easily available. The customer can readily access power output, ALC status, VSWR, PA temperature, and other basic operating parameters, The BTI NMS simplifies the configuration of the network by providing accurate downlink power and uplink gain updates. This allows the system operator to maximize the efficient use of field personnel when diagnosing system performance issues.

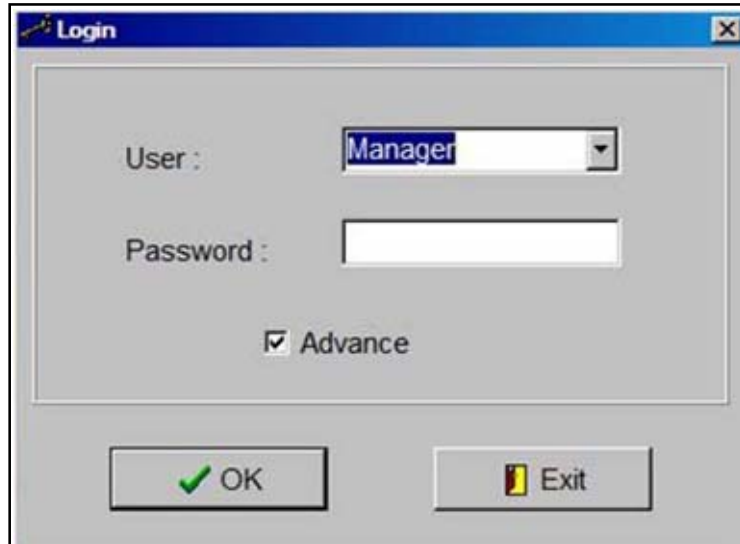

Figure 3-6. NMS Login Interface



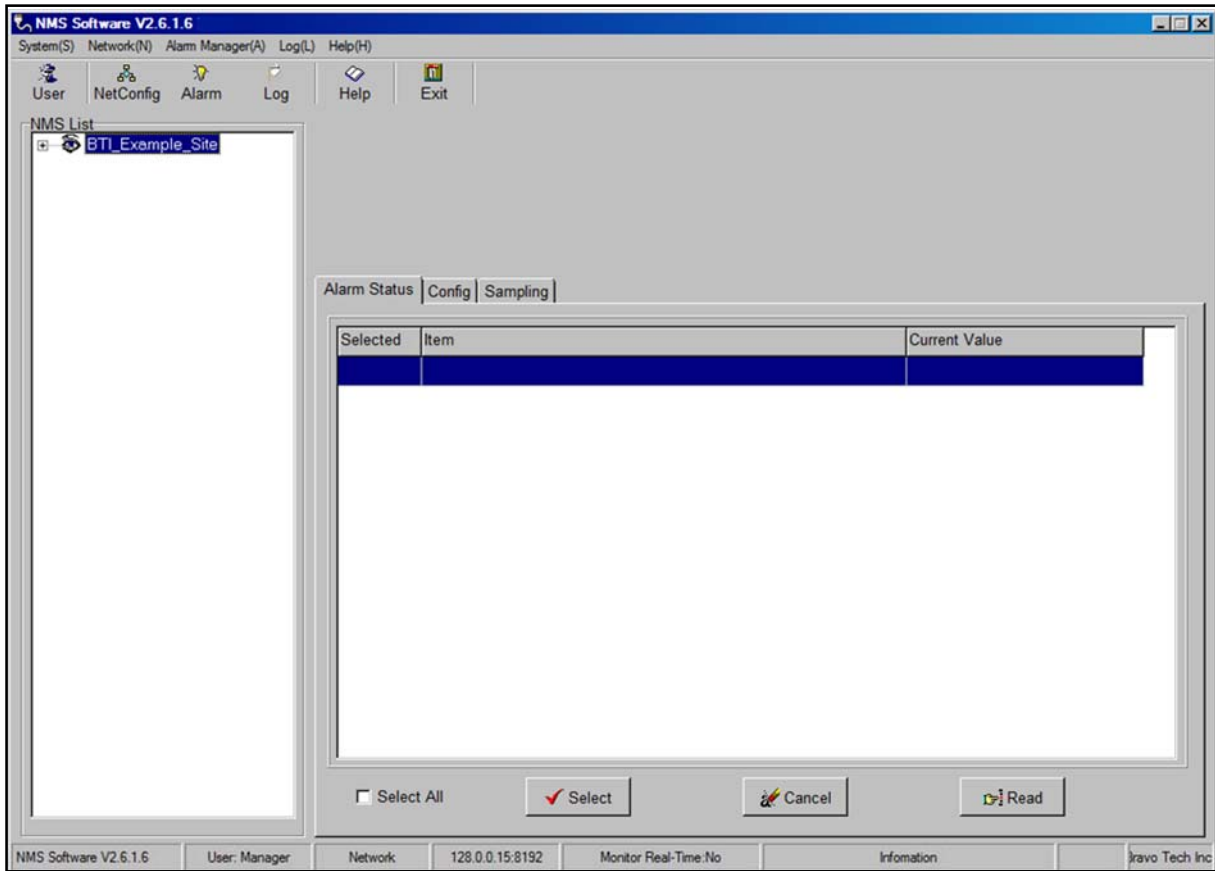

Figure 3-7. NMS Command Console

Table 3-2. Default Parameter Values

Menu	Parameter Name	Default Value
System Parameter	SNMP	No
User	Manager	Name: Manager; Password: 1; Level: Supervisor
User	User	Name: User; Password: 1; Level: Observer

### 3.2.3 Remote Unit Interface

The interface of the Remote Unit consists of connectors and LEDs that are located on the bottom of the RU enclosure. The Master RU user interface points are indicated in **Figure 3-8** and **Table 3-3**. The Slave RU user interface points are indicated in **Figure 3-9** and **Table 3-4**.

Remote Units are classified as either **MASTER** or **SLAVE**. Master and Slave Units have exactly the same mechanical dimensions. Functionality is the main difference as the **MASTER** Remote Unit has the connection for the fiber optic cable. For supporting multiple bands, only the **MASTER** Remote Unit needs to have the fiber optic connection with the Host Unit. Other Remote Units are interfaced with **SLAVE** ports for receiving RF downlink signal and sending RF uplink signal with the Master Remote Unit.

- MASTER Remote Unit:
  - Has the Fiber Optic Cable connection with the Host Unit
  - Provides the RF downlink signal to the SLAVE Remote Unit through “TX\_IN” or “TX\_OUT” port.
  - Receives the RF uplink signal from the SLAVE Remote Unit “RF\_IN” or “RF\_OUT” port.

- SLAVE Remote Unit:
  - No Fiber Optic Cable connection with the Host Unit
  - Interfaces with the Master Unit for downlink and uplink signal
  - Unused ports (TX\_OUT, RX\_IN) are blocked with a cover.

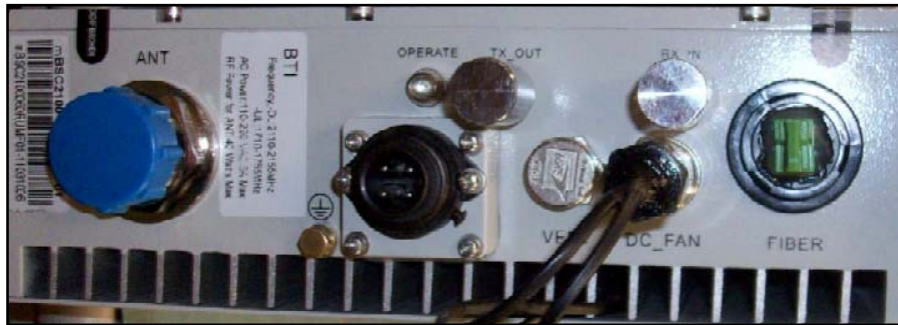

Figure 3-8. User Interface of MASTER Remote Unit

Table -3-3. Master Remote Unit User Interface

Label Name	Description
ANT	Interface port for Antenna Feed line
OPERATE	LED indicator for normal or critical fault status of the RU. Normal: Green ON, Critical fault: Red ON
TX_Out	RF output port to provide the input signal to the Slave Remote Unit when Dual or Triple Band application is configured.
RX_In	RF input port to provide the output signal to the Master Remote Unit when Dual or Triple Band application is configured.
FIBER	Fiber Optic Cable interface port for combined downlink and uplink signal
POWER	Interface port for the AC 110/220V power cable
DC_FAN	Provides power to the fan
VENT	Port for the balance of pressure inside and outside of the enclosure



Figure 3-9. User Interface of SLAVE Remote Unit

Table -3-4. Slave Remote Unit User Interface

Label Name	Description
ANT	Interface port for Antenna Feed line
OPERATE	LED indicator for normal or critical fault status of the RU. Normal: Green ON, Critical fault: Red ON

TX_Out (Slave 1)	RF output port to provide the input signal to the Slave Remote Unit when Dual or Triple Band application is configured
RX_In (Slave 2)	RF input port to provide the output signal to the Master Remote Unit when Dual or Triple Band application is configured.
POWER	Interface port for the AC 110/220V power cable
DC_FAN	Provides power to fan
VENT	Port for the balance of pressure inside and outside of the enclosure

## 3.3 SPECIFICATIONS

### 3.3.1 Host Unit Specifications

The specifications for the Host Unit of the mBSC DAS system are listed in **Table 3-5**:

**Table 3-5. Host Unit Specifications**

Host Unit Specification	Description	Notes
System	Support Multi-Frequency bands with Multi-Air Interface standards (GSM / EDGE / CDMA / WCDMA / AWS / LTE)	
Max No. of Plug-in module	<ul style="list-style-type: none"> <li>3 fixed slots for two (PSU) and a single (RCU)</li> <li>6 module slots for BIU and FIU</li> </ul>	
PSU (Power Supply Unit)	<ul style="list-style-type: none"> <li>-48Vdc and optional AC 110/220 DC converter</li> <li>2 PSU are installed for redundancy</li> </ul>	
RCU (Remote Controller Unit)	Main process board for DAS system	
BIU (Base station Interface Unit)	<ul style="list-style-type: none"> <li>Support multi-frequency bands DL and UL interface</li> <li>Support RX Diversity</li> <li>QMA connector for RF Interface</li> <li>Support 4 downlink and uplink interface ports</li> </ul>	
FIU (Fiber Interface Unit)	<ul style="list-style-type: none"> <li>Support 2 Fiber ports per FIU</li> <li>Support Non-Simulcast or Simulcast</li> </ul>	

### 3.3.2 NMS Specifications

The specifications for the Network Management System (NMS) of the mBSC system are listed in **Table 3-6**.

**Table 3-6. NMS Specifications**

NMS Specification	Specification	Notes
Max No. of Nodes	1080	A combination of BIU, FIU and Remote Units
SNMP based management	Yes	
Real time alarm display	Yes	
Display various system level values	Yes	Voltages, RF power, etc.
Remote firmware download	Yes	Firmware update interface for DAS components.

The NMS also requires a dedicated server to connect to the RCU. The Server specifications are

**Table 3-7. Server Specifications**

Server Specification	Specification	Notes
Processor	One Quad-core Intel® Xeon® 3400 series processor	

Server Specification	Specification	Notes
Operating System	Microsoft® Windows® XP Professional	
Memory	4GB (4 DIMM slots) DDR3	
Storage	<b>Cabled Hard Drive Options:</b> 2.5" SATA SSD, SAS (10K), nearline SAS (7.2K) <b>Maximum Internal Storage:</b> 250G	
Power	Single cabled power supply (250W)	
Video Card	Matrox G200eW w/ 8MB memory	
Network Controller	One dual-port Broadcom BCM 5716	

### 3.3.3 Remote Unit

The specifications for the Remote Unit of the mBSC system are listed in **Table 3-8**.

**Table 3-8. Remote Unit Specifications**

System Specification	Downlink	Uplink
Optic Wavelength	1310/1550nm	
Antenna Port	7/16 DIN female	
Optical connector	E2000	
Power Supply	AC 110V / 220V ± 20%	
Current	< 1A @ Full power, ~220V AC input < 2A @ Full power, ~110V AC input	
Weight	varies per type	
Waterproof	IP65	

## **4 INSTALLATION**

### **4.1 SYSTEM INSTALLATION OVERVIEW**

This section provides instructions for installing the mBSC DAS system in an efficient, productive and customer friendly order. Each component of the mBSC DAS system is covered in its own installation section as follows:

#### **4.2.REMOTE UNIT INSTALLATION**

The Remote Unit installation section provides instructions for the mechanical and electrical installation of the mBSC Remote Unit including: mounting the Remote Unit, connecting the fiber optics cables; Antenna feed line; and AC power cables.

The procedures in this section assume that the required Fiber Optic cables have been routed between the Host Unit and the Single-Band RU and that the required antenna has been installed.

#### **4.3.HOST UNIT INSTALLATION**

The Host Unit installation section provides instructions for the electrical installation of the mBSC Host Unit including verifying the DC power cable connection, connecting the network cable, the alarm connectors, and other required connections and cables.

The procedures in this section assume that the Host Unit has been inspected, the Remote Unit(s) installation is complete and that a dedicated IP address for the Host Unit has been designated.

#### **4.4.NMS INSTALLATION**

The Network Management System (NMS) installation section provides instructions for setting up the pre-installed software component of the mBSC NMS. The instructions will allow a qualified user to install the NMS software, set-up accounts, change passwords for security, and upgrade the system software and hardware.

The procedures in this section assume that the NMS server has been received, the Host Unit is installed, and that security software has been installed on the designated NMS computer(s).

## 4.2 REMOTE UNIT INSTALLATION



**Danger:** Wet conditions increase the potential for receiving an electrical shock when installing or using electrical power equipment. To avoid electrical shock, never install or use the electrical equipment in a wet location.



**Danger:** Do not look into the end of the fiber optic cables. Exposure to laser radiation may result. Do not assume that the laser power is turned off or that the fiber optic cable is disconnected at the other end.



**Danger:** Use extreme caution when working with high voltage AC power. Ensure all power is disconnected before working on power circuit.



**Caution:** Always make sure there is sufficient cable length to permit the routing of the fiber optic cables to prevent the cable damage. The optic cables may be damaged if bent or coiled too tightly.

### 4.2.1 Remote Unit Installation Overview

The installation of the Remote Unit, both single enclosure and multi-enclosure, consists of the following steps:

**Table 4-1. Remote Unit Installation Overview**

Step	Operation Type	Operation Action
1	MECHANICAL	INSTALL THE RU MOUNTING PANEL TO THE TOWER
2	MECHANICAL	VERIFY THAT THE SIDE MOUNTING BRACKETS ARE SECURELY ATTACHED TO THE REMOTE UNIT
3	MECHANICAL	INSTALL THE MASTER REMOTE UNIT ON THE MOUNTING PANEL
4	MECHANICAL	MOUNT THE SHROUD COVER OVER THE ENCLOSURE AND SECURE IT
5	INSTALLATION REVIEW	CONFIRM THE MECHANICAL INSTALLATION USING <b>TABLE 4-4 MECHANICAL INSTALLATION CHECKLIST</b>
6	ELECTRICAL	GROUND THE UNIT
7	ELECTRICAL	ROUTE THE CABLES TO BE CONNECTED
8	ELECTRICAL	CONNECT THE FIBER OPTIC CABLES
9	ELECTRICAL	CONNECT THE ANTENNA FEED LINE
10	ELECTRICAL	INSTALL THE AC POWER CABLE
11	ELECTRICAL	CONNECT ANY SLAVE REMOTE UNIT TO THE MASTER REMOTE UNIT
12	INSTALLATION REVIEW	CONFIRM THE ELECTRICAL INSTALLATION USING <b>TABLE 4-5 ELECTRICAL INSTALLATION CHECKLIST</b>
13	FIELD STATUS TEST	CHECK THE REMOTE UNIT LED STATUS INDICATORS USING <b>TABLE 4-6 RU LED STATUS INDICATOR AND THE TROUBLESHOOTING GUIDE</b>

### 4.2.2 Installation Hardware And Tools

The Remote Units are shipped with the standard mounting hardware required for a BTI pole-mount  
© 2009-2011, BTI Page 22

installation. **Table 4-2** lists the mounting hardware provided by the manufacturer for a BTI non-custom pole mount installation kit. Additional hardware may be needed, depending on the site requirements, and may be ordered through Customer Service (Section 6).

**Table 4-2. Single-Band RU Mounting Hardware and Fasteners  
for a BTI non-custom pole mount installation kit**

Hardware and Fasteners	Quantity	Rec'd
MOUNTING PANEL (Configurable)	1	
I-BEAM or U-BEAM/CHANNEL MOUNTING BRACKETS	2	
SHROUD COVER	1	
M5 SCREW	8	
M5 LOCK WASHER	8	
M5 FLAT WASHER	8	
M6 SCREW	8	
M6 LOCK WASHER	8	
M6 FLAT WASHER	8	
M8 SCREW	8	
M8 LOCK WASHER	8	
M8 FLAT WASHER	8	
M12 SCREW	4	
M12 LOCK WASHER	4	
M12 FLAT WASHER	4	
JUNCTION BOX	1	
RF CABLE (Designated Slave Unit)	2	
FIBER OPTIC COWL	1	
POWER CABLE (10 FEET)	1	
FAN CONNECTOR (OPTIONAL)	1	

**Table 4-3. Specified Hardware Torque**

Type	Screws	Hex Nuts		Spacers Spring/Lock Washers			Spacers Flat Washers		
		M8	M12	M5	M8	M12	M5	M8	M12
Thread	M5	M8	M12	M5	M8	M12	M5	M8	M12
Specified Torques (lb. - ft.)	2	12	40	2	12	40	2	12	40

The following is a list of tools and any additional materials required for mounting every Single-Band Remote Unit configuration:

- DIN male connectors
- Tool kit for attaching DIN connectors to coaxial cable
- Tools for installing exterior AC circuit
- Tools for securing M5 screw

- Wire cutters
- Wire Stripper
- Open End Wrench 1.25 inch/33mm (used for DIN connector)
- Hex Wrench 5mm (M6 screw)
- SAE Wrench 5/16 inch/8mm (the Slave Remote Unit connectors)

### 4.2.3 Unpacking And Inspection

This section provides the instruction for receiving the equipment shipment, verifying all parts have been received and checking that no damage has occurred during transportation. The Remote Unit includes the following items:

- Remote Unit(s)
- Hardware and Fasteners described in **Table 4-2, Section 4.2.2**

Use the following procedure to unpack and inspect the Remote Unit and accessories:

1. Open the shipping packet and carefully unpack the Remote Unit(s) and any accessories from the protective packing material.
2. Verify receipt of hardware and fasteners using **Table 4-2**
3. Check each Remote Unit and accessories for broken or missing parts. If there is any damage or missing parts, contact BTI (Section 6) for an RMA and to reorder parts, if any replacement parts are required.



*NOTE: Check particularly for any damage to the power connection, the fins/fans, and the fiber optic cable connection on the Remote Unit Interface.*



## 4.2.4 Mechanical Installation

### 4.2.4.1 Mechanical Safety Precautions

Please read the general Safety Precautions contained in Section 1.2 *Safety Precautions*

1. Follow the procedures provided by the manufacturer when installing the Remote Unit. Do not install the Unit in a place or in a manner that does not meet the manufacturer's provided specifications.
2. Use the mounting hardware supplied by the manufacturer. If non-standard mounting hardware is used, it must meet the requirements for mounting the Unit as specified by the manufacturer.



*NOTE: It is important that specified load limits for the Unit are not exceeded as this may void the warranty.*

3. Safety measures for lifting heavy materials should be followed to prevent injury.
4. High temperatures may occur due to power dissipation. Please follow the specifications for proper Remote Unit ventilation as indicated by the manufacturer.
5. Check that the mains supply is disconnected, before connecting or disconnecting the main power connector at the Remote Unit.
6. Do not block airflow ventilation outlets during installation or Remote Unit(s) may sustain critical damage.

#### **4.2.4.2 Install The Mounting Panel**

Use the following procedure to install the mounting panel on the pole:

1. Take one M12 screw and insert it loosely in one of the two top holes in the panel. Place the mounting panel against the pole as shown in **Figure 4-1**.
2. Place one of the two I-Beam or U-Beam brackets on the back side of the pole so that it aligns with the M12 screw.
3. Hand tighten the screw to hold it in place
4. Place the second M12 screw in the next hole at the top of the panel and loosely fasten the screw as well. Continue until all four screws are in place as shown in **Figure 4-2**.
5. Use a wrench to securely fasten the screws through both panel and brackets until the panel is securely attached to the pole.



**Figure 4-1. Attach the Mounting Panel and Bracket to a Pole**

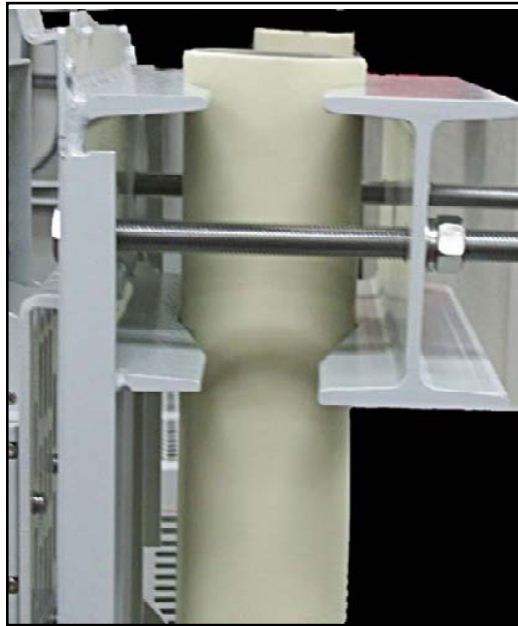
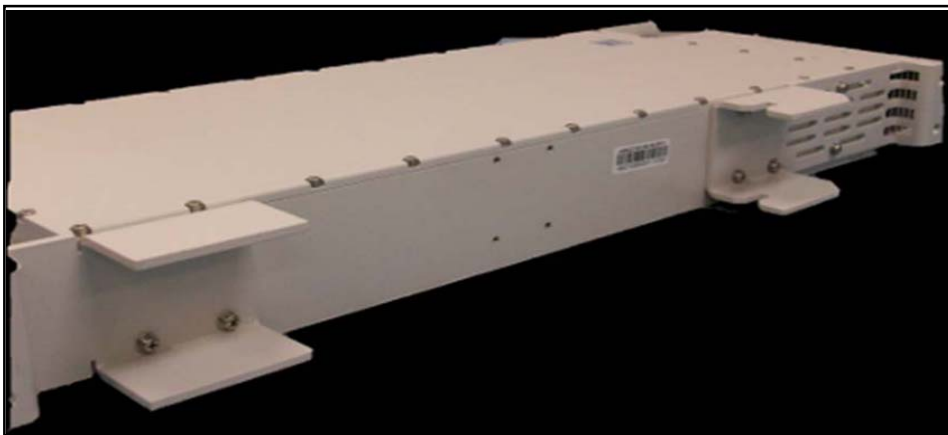

**Figure 4-2. The Mounting Panel secured tightly to a Pole**

#### ***4.2.4.3 Install The Remote Unit On The Mounting Panel***

Use the following procedure to install the RU on the mounting Panel.

1. Verify that the attached side mounting brackets, as shown in **Figure 4-3** are secure.
2. Grasp the Remote Unit at the top and bottom of the casing and carefully slide the top two hooks onto the mounting panel, **Figure 4-4**, followed by the lower hooks and allow the Unit to slide down into place.
3. After hanging the enclosure on the mounting panel, use the M8 screws, lock and flat washers to secure the rear mounting bracket (top and bottom) so the RU does not move.



**Figure 4-3. The Side Mounting Bracket to the Mounting Panel**

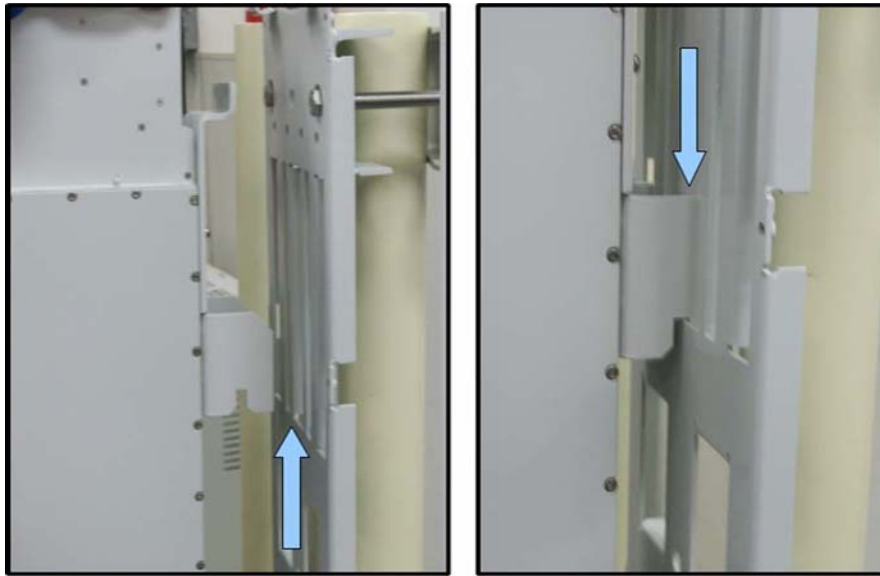

**Figure 4-4. Secure Enclosure To the Side Mounting Bracket**

#### ***4.2.4.4 Install The Shroud Cover***

The Remote Unit has a Shroud cover for thermal protection.

Use the following procedure to install the Shroud cover on the enclosure:

1. Line up the slots at the top of the Shroud cover to the tabs at the top of the mounting panel as shown in **Figure 4-5**.
2. Gently lower the slots over the tabs and slide the cover down. The cover will be at an angle, **Figure 4-6**.
3. Lay the cover flush against the mounting bracket, then carefully, place the M5 screw through the middle hole, aligning it to the hole on the bracket. Loosely fasten the screw. Working on the opposite side, again place an M5 screw through the middle hole and loosely fasten the screw.
4. Loosely fasten the remaining M5 screws to all four corners of the cover and then tighten all the screws securely.

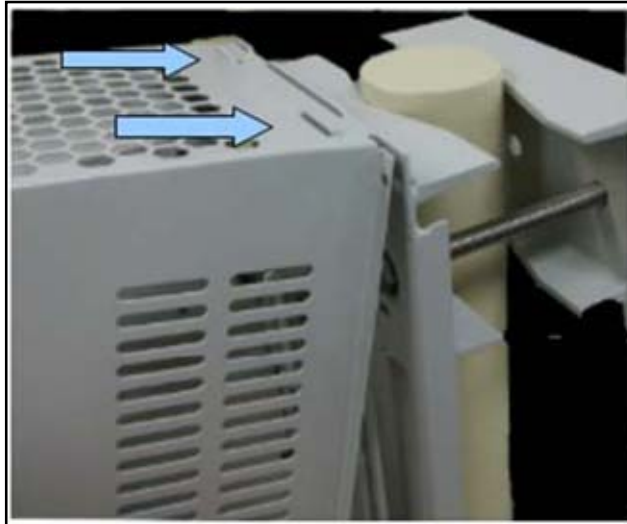

**Figure 4-5. Install the Shroud Cover to the RU**



**Figure 4-6. Secure Shroud Cover to the mounting panel**

## 4.2.5 Electrical Installation

### 4.2.5.1 Electrical Safety Precautions

Please read the general Safety Precautions presented in Section 1.2 *Safety Precautions*



1. This Unit uses high voltages. Follow the instructions for installation provided in this manual to prevent serious accidents including loss of life, severe personal injury or extensive property damage.



2. The Unit must be grounded before connecting any power supply. Grounding is a required precautionary measure. Grounding instructions are provided and should be followed for safety.
3. The Unit is internally protected against over-voltage, but in areas with strong and frequent lightning strikes additional lightning protection is strongly recommended. Grounding the antenna cables close to the antenna connectors will help prevent damage from atmospheric discharge.
4. Verify that there is a suitable circuit breaker and an over-current limiting device connected between the mains and the Remote Unit.
5. Check that the mains supply is disconnected, before connecting or disconnecting the main power connector at the Remote Unit.
6. An easily reached emergency disconnect device should be provided in the mains circuit if the power feeds to the Remote Unit(s) are not within close reach.
7. The Remote Unit should be installed in close proximity to a power source with a circuit breaker to ensure safe installation and for ease of power connectivity.
8. Electrical and electronic components can be destroyed by incorrectly wired connections.
9. Cable connector materials must meet manufacturer specifications to avoid corrosion at the connectors.
10.  Check cable connections to ensure that water cannot penetrate the Unit.
11. Caution should be used when attaching the antenna. Hand tightening should be sufficient for connecting the antenna during installation. Manufacturer's recommendation for torque specification should be used during installation. Use the appropriate tool to complete the Antenna installation, but do not use tools, such as pliers, as they may cause damage to the Remote Unit.
12. A voltage limiting device is strongly recommended for electrical networks that often produce spikes.
13. Compliance with the surge requirement of EN 61000-4-5 (fine protection) has been met by this Unit. Installing additional external surge protection, depending on the individual application, via local supply connection and/or coarse protection is recommended to avoid damage caused by electrical surges.

### 4.2.5.2 Grounding



The Unit must be grounded. Connect an earth-bonding cable to the provided grounding connection. Do not connect any additional external devices to the grounding connection.



Figure 4-7. Grounding Connection

1. Uncover the RU interface by removing the Vandalism Protective Shield from the bottom of the Shroud Cover.
2. Loosen the hex nut located on the grounding connection as shown in **Figure 4-7**.
3. Connect the earth-bonding cable between the two lock and flat washers.
4. Tighten the hex nut, making sure the cable is securely connected before moving to the next phase of the installation.

### 4.2.5.3 Route the Cables

Prepare and route all cables according to standard field installation procedures. Care should be taken to prevent wear or field damage to cables during install. Particular attention should be paid to the Fiber Optics Cable as damage may occur if cable is tightly coiled or bent.

### 4.2.5.4 Fiber Optic Cable Connection

One fiber optic cable must be routed from an external splice enclosure or fiber access terminal to the Master Remote Unit enclosure. The RU is equipped so only one cable is required per Master Remote Unit for the optic port. A hardened optical E2000 connector is used for the optic port.



**Warning:** Do not look into the end of the fiber optic cable. Do not look directly into the optical transmitter of any Unit or exposure to laser radiation may result. An optical power meter should be used to check the active fibers.

Use the following procedure to connect the fiber optic cable:

1. Connect or splice the drop Fiber cable to the outside plant cable. Verify that there is sufficient cable length to reach from the splice enclosure or fiber access terminal (not provided) to the bottom of the Master Remote Unit

2. Route the free end of the drop cable to the enclosure through the junction box as shown in **Figure 4-8**.
3. Leave sufficient slack to allow the cable to be connected and disconnected from the enclosure fiber optic port without bending or crimping the fiber optic cable.
4. Remove the cap from the interface port labeled "FIBER". Connect the fiber optic cable to the port on the bottom of the enclosure.

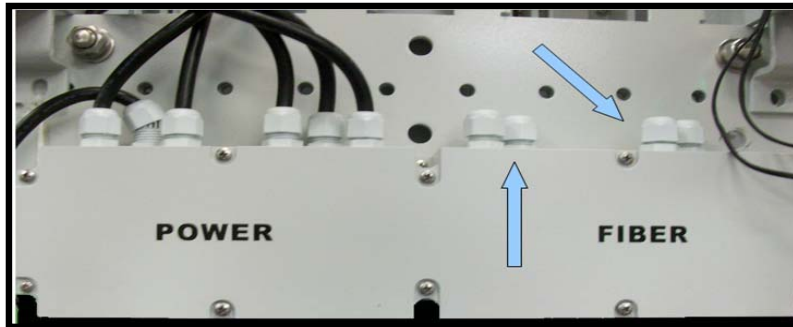

**Figure 4-8. Junction Box**

#### **4.2.5.5 Antenna Cable Connection**

The antenna feed line(s) must be routed from the antenna to each Remote Unit. The cable must have the appropriate antenna connector termination to connect to the RU antenna port (ANT), shown in **Figure 4-9**.



**Figure 4-9. Antenna port**

Use the following procedure to install the antenna cable:



*NOTE: When using multiple RU enclosures to support more than one RF band, each RU is supporting a different frequency. When routing the coaxial antenna cable, it is critical that the appropriate frequency band cable be connected to the same frequency type RU.*

1. Remove the dust cap from the DIN female connector located on the bottom of the enclosure. The port is labeled with "ANT".
2. Route the coaxial antenna cables from the antenna to the bottom of the enclosures.
3. Cut the antenna cable to the required length and terminate with the appropriate connector.



4. Connect the antenna cable to the antenna port labeled with "ANT", **Figure 4-10**.



**Figure 4-10. DIN Female Connector**

#### **4.2.5.6 AC Power Cable Connection**



**Danger:** Use extreme caution when working with high voltage AC power. Ensure all power is disconnected before working on power circuit.



**Warning:** Verify that the Unit has been ground with an earth-bonding cable to the grounding connector.

Use the following procedure to install the AC Power cable:

1. Route the power cable between the AC power port, located on the bottom of the enclosure and the nearest AC power junction box as shown **Figure 4-11**.



**Figure 4-11. Junction Box AC Power Cable Routing**

2. Secure the cable between the AC power port and the AC power junction box. Leave sufficient slack in the cable to allow it to be easily connected and disconnected from the AC power port.
3. Install any AC power supply wires that may be required between the AC junction box and the AC circuit breaker box.
4. At the AC circuit breaker box, connect the AC power supply load wire to the circuit breaker.
5. Place the circuit breaker in the ON position and then test the connected end of the AC power cable for proper voltage levels and correct polarity.

6. When testing is complete,  **PLACE THE CIRCUIT BREAKER IN THE OFF POSITION.**



**Danger:** To avoid serious personal injury and equipment damage, always turn the AC power **off** on the circuit breaker before connecting the any power cable to the AC power port.

7. Connect the power cable connector to the AC power port labeled "POWER".
8. Tighten the coupling nut.

#### **4.2.5.7 Slave Cable Connection**

When two RU or more enclosures are installed for supporting multi-band. One is designated the Master Remote Unit and each additional RU, up to two Units, are designated as slave Remote Units. The Master and slave Unit(s) is specified by the frequency band. The Master Unit will separate the bi-directional signal related to the frequency and provide the RF input signal to each slave Remote Unit. The connection between Master and Slave is interfaced with the RF cable provided with the Remote Units.

Use the following procedure to install the antenna cable:

1. All designated slave RUs arrive with two RF cables.
2. Connect one RF cable to the port labeled "TX\_OUT" on the **MASTER** Remote Unit User Interface.
3. Connect the other end of the RF cable to the port labeled "TX\_IN" on the **SLAVE** Remote Unit User Interface as shown in **Figure 4-12**.
4. Connect the second cable to the port labeled "RX\_IN" on the **MASTER** RU.
5. Connect the other end of the second RF cable to the port labeled "RX\_OUT" on the **SLAVE** RU.



Figure 4-12. RF cable connection between Master and Slave Remote Unit

- 1 **Slave to Slave Connection:** Connect an RF cable into the port labeled "TX\_OUT" on the first **SLAVE** RU User interface.
- 2 Connect the other end of the RF cable to the port labeled "TX\_IN" on the next **SLAVE** RU Unit. Continue connecting all **SLAVE** RUs in this manner, as shown in **Figure 4-13**.
- 3 Connect an RF cable into the port labeled "RX\_OUT" on the first **SLAVE** RU.
- 4 Connect the other end of the RF cable to the port labeled "RX\_IN" on the next **SLAVE** RU. Continue connecting all **SLAVE** RUs in this manner.
- 5 Power may now be applied to all Master and Slave Units used in this configuration.

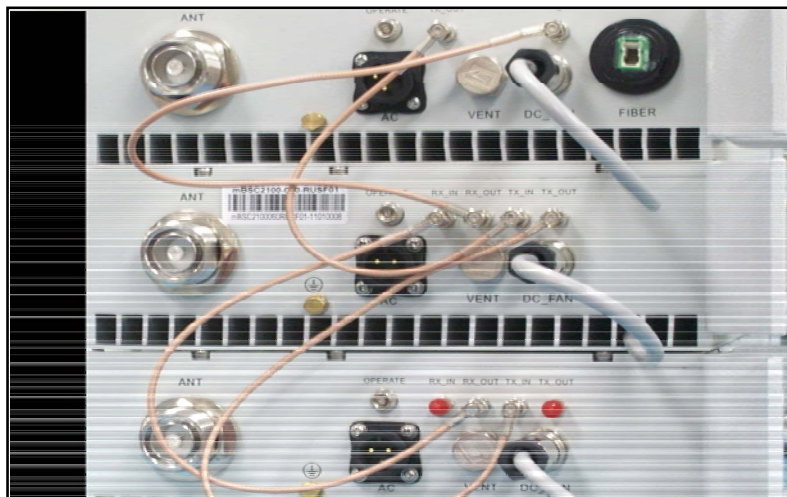

Figure 4-13. RF cable connection between Slave to Slave Remote Units

## 4.2.6 Remote Unit Installation Review

Use the following steps listed in Tables 4-3 and 4-4 to review the installation completion status

### 4.2.6.1 Mechanical Installation Review

**Table 4-4. Remote Unit Mechanical Installation Check Lists**

Items	Description
1	Confirm that the Unit is mounted firmly and is stable.
2	Verify that the Unit is affixed per manufacturer's specifications.
3	Check that all screws and nuts are secure, that spring washers sit flush upon the flat washers, and that there are no missing flat washers and spring washers.
4	Examine each part and cable for breakage or damage.
5	Make sure the Unit is clean and free of dust and other contaminants

### 4.2.6.2 Electrical Installation Review

**Table 4-5. Remote Unit Electrical Installation Check List**

Items	Description
1	Verify that the grounding cable is secure.
2	Make sure that all the cable sheathings are not damaged.
3	Confirm that the connection to the cables are stable and are not loose or damaged.
4	Check that the cables are completely connected, but make sure there is enough slack, if needed. Do not cross the cables and the cables should be bundled together in the same direction.
5	Check that the connected cables are not bent more than the manufacturer's specified maximum bending radius.

### 4.2.6.3 Field Status Test - Remote Unit LED Status Indicators

Perform a visual review of the LED Status indicators on the installed Remote Unit. The Remote Unit (RU) status LED consists of a bi-colored LED of RED and GREEN. The high intensity LED is viewable from ground level under most circumstances when using the BTI RU shroud system.

**Table 4-6. Remote Unit LED Status Indicators**

LED Indicator	Colors	Cycles
Test the LED	Red and Green Blink	1 flash per second
Master RU Fiber Alarm	Red Fast Blink	2 times per second
mRU and sRU Comm Fail	Red and Green Blink	1 time per second
PA/LNA shutdown or Other	Red Fast Blink	2 times per second
Normal Operation	Green Blink	1 times per second

## 4.2.7 Troubleshooting

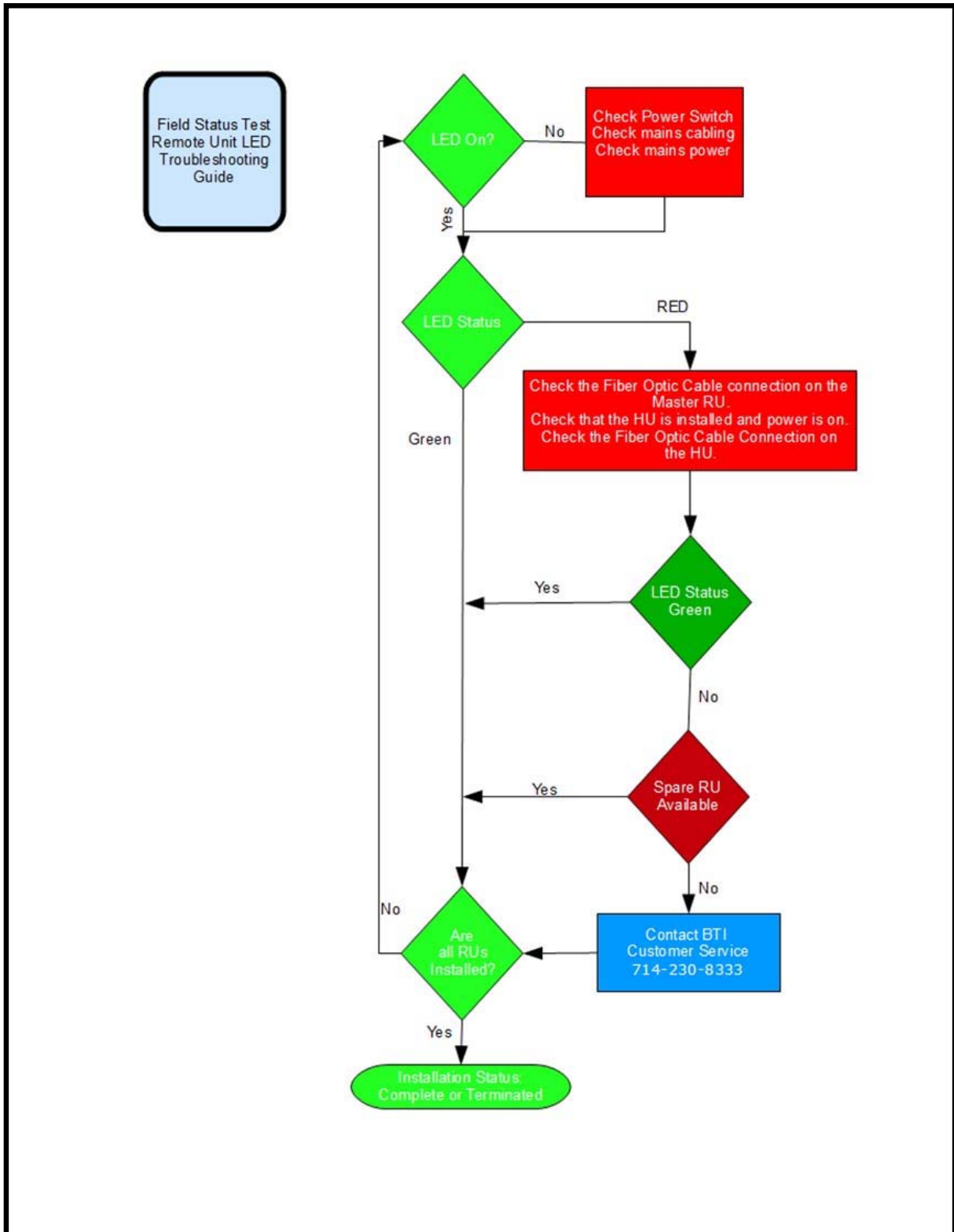

## 4.3 HOST UNIT INSTALLATION



**Danger:** Wet conditions increase the potential for receiving an electrical shock when installing or using electrical power equipment. To avoid electrical shock, never install or use the electrical equipment in a wet location.



**Warning:** Verify that the Unit has been ground with an earth-bonding cable to the grounding connector.

### 4.3.1 Host Unit Installation Overview

The installation of the Host Unit consists of the following steps:

**Table 4-6. Host Unit Installation Overview**

Step	Operation Type	Operation Action
1	ELECTRICAL	VERIFY THAT THE UNIT IS GROUNDED
2	ELECTRICAL	CONFIRM THAT THE DC POWER CABLE IS INSTALLED AND SECURE
3	ELECTRICAL	INSTALL THE BIU AND FIU MODULES
4	ELECTRICAL	INSTALL THE ALARM CONNECTORS (Optional)
5	ELECTRICAL	CONNECT THE BIU AND FIU
6	ELECTRICAL	CONFIRM THAT THE POI AND FAN (Opt. Equip.) ARE CONNECTED
7	ELECTRICAL	CONNECT OPTIONAL EQUIPMENT TO THE BIU (if present)
8	ELECTRICAL	CONNECT THE FIBER OPTIC CABLES
9	INSTALLATION REVIEW	CONFIRM THE ELECTRICAL INSTALLATION, <b>TABLE 4-10 HOST UNIT ELECTRICAL INSTALLATION CHECKLIST</b>
10	TROUBLESHOOTING	INSTALLATION TROUBLESHOOTING GUIDE

### 4.3.2 Installation Hardware And Tools

The Host Units may be shipped individually or shipped factory pre-installed in optional cabinets. **Table 4-7** lists the cables and hardware provided by the manufacturer. Additional hardware may be needed, depending on the site requirements, and may be ordered through Customer Service (Section 6).

**Table 4-7. Host Unit Cables and Hardware**

Single Host Unit Hardware and Fasteners	Customer Install	Factory Install	Rec'd
CABINET (Optional)	1		
HU DC POWER CABLE		1	
ALARM CONNECTORS	8		
FIU-S INTERFACE CABLE	3		
FIU-NS INTERFACE CABLE	4		
GROUNDING CABLES		1	
POI GROUNDING CABLE (Optional)		1	

Single Host Unit Hardware and Fasteners	Customer Install	Factory Install	Rec'd
POI INTERFACE CABLE	4		

The following is a list of tools and any additional materials required for the Host Unit installation:

- Small Phillips screwdriver
- Wire cutters
- Wire Harness (Required for Expanded Third Party Alarm)

### 4.3.3 Unpacking And Inspection

This section provides the instruction for receiving the equipment shipment, verifying all parts have been received and checking that no damage has occurred during transportation. The Host Unit includes the following items:

- Optional Cabinet with Host Unit installed as shown in **Figure 4-14**.
- Hardware and Fasteners described in **Table 4-7, Section 4.3.2**

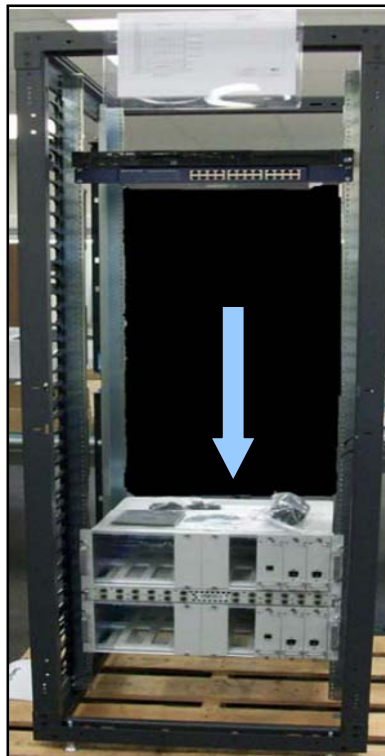

**Figure 4-14. Host Unit Cabinet**

Use the following procedure to unpack and inspect the Host Unit and accessories:

1. Open the shipping packet and carefully unpack the cabinet or individual Host Unit from the protective packing material.
2. Verify receipt of hardware and fasteners using **Table 4-7**
3. Check each optional cabinet for broken or missing parts. Check each Host Unit module for any damage, particularly the Fiber Optic Port. If there is any damage or missing parts, contact BTI (Section 6) for an RMA and to reorder parts, if any replacement parts are required.



**NOTE:** Check particularly for any damage to the fiber optic connectors on the FIU module. Check the power connectors located at the back of the Host Unit and check the back plane connectors located inside the Host Unit for any damage.

## 4.3.4 Electrical Installation

### 4.3.4.1 Electrical Safety Precautions

Please read the general Safety Precautions presented in Section 1.2 *Safety Precautions*



1. Follow the instructions for installation provided in this manual to prevent serious accidents including loss of life, severe personal injury or extensive property damage.



2. The Unit must be grounded before connecting any power supply. Grounding is a required precautionary measure. Grounding instructions are provided and should be followed for safety.

3. Electrical and electronic components can be destroyed by incorrectly wired connections.

4. Cable connector materials must meet manufacturer specifications to avoid corrosion at the connectors.

5. Compliance with the surge requirement of EN 61000-4-5 (fine protection) has been met by this Unit. Installing additional external surge protection, depending on the individual application, via local supply connection and/or coarse protection is recommended to avoid damage caused by electrical surges.



### 4.3.4.2 Grounding



The Unit must be grounded. The Host Unit is grounded during a factory installation in the optional cabinet with an earth-bonding cable connected to the provided grounding connection. Do not connect external devices to the grounding connection.

Please verify the Unit is securely grounded. If it is no longer securely grounded, please use the following procedure to ground the Unit:



**Figure 4-15. Host Unit Grounding Connection**

1. Find the screw at the bottom right corner of the Host Unit as shown in **Figure 4-15**.
2. Loosen the screw located on the grounding connection.
3. Connect the cabinet mounted earth-bonding cable between the two lock and flat washers as shown in **Figure 4-16**. Ensure the grounding surface is clean and free of paint, insulating material or contaminants.

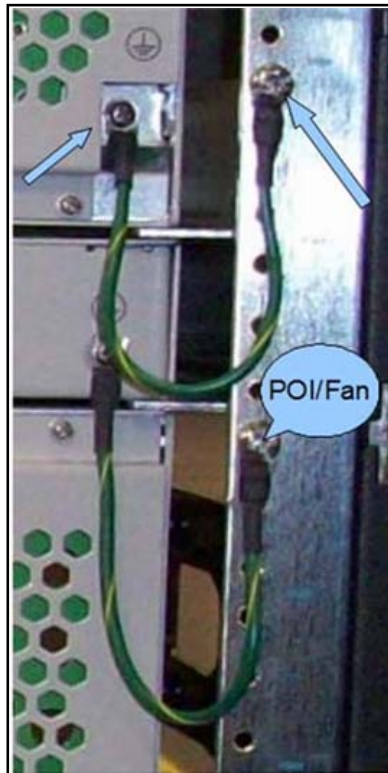

**Figure 4-16. Grounded Host Unit (shown with optional POI Unit, also grounded)**

4. Tighten the screw, making sure the cable is securely connected before moving to the next phase of the installation.

#### **4.3.4.3 DC Power Cable Connection**



**Danger:** Please use caution when working with DC power. Ensure all power is disconnected before working on power circuit.



**Warning:** Verify that the Unit has been ground with an earth-bonding cable to the grounding connector.

The DC power cable is connected during factory pre-installation.

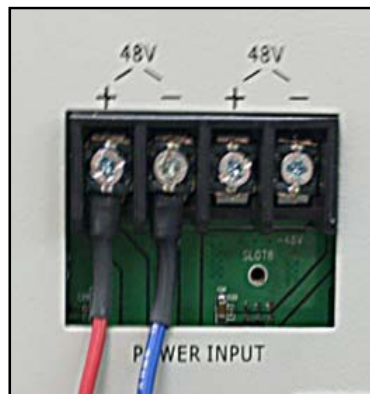

**Figure 4-17. Factory Installed DC Power Cable**

1. Confirm electrical polarity of the power cables to match the customer provided DC power system.
2. Verify the DC power cable is attached securely, as shown **Figure 4-17**.
3. If the DC power cable is not secure, turn off all associated DC power to the Host Unit, and secure the power cables as shown.

#### ***4.3.4.4 Install the BIU and FIU modules***

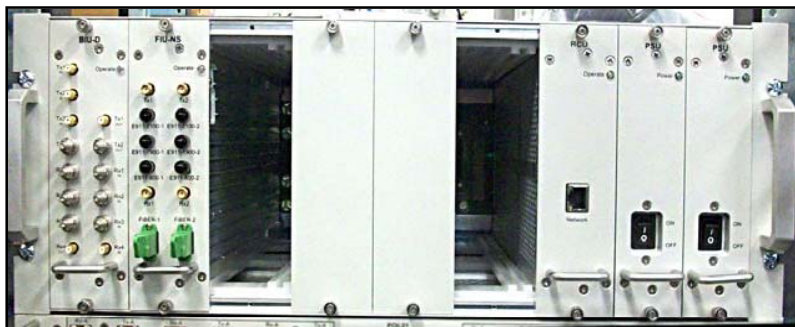

**Figure 4-18. BIU and FIU modules**

1. Remove the blank module covers for the chosen module slot locations.
2. Slide the BIU and FIU modules in to each separate designated module slot, **Figure 4-18**.
3. Secure the screws at the top and bottom of each module.

#### ***4.3.4.5 Alarm Installation***

The Alarm interface is an optional customer centered configuration.

The Alarm Input configuration gives the user the means to monitor third party alarms, such as battery or intrusion alarms.

The Alarm Output configuration provides the customer with the means to monitor major or minor alarms via Form C relay.

The alarm interface is located at the back of the Host Unit as shown in **Figure 4-19**.

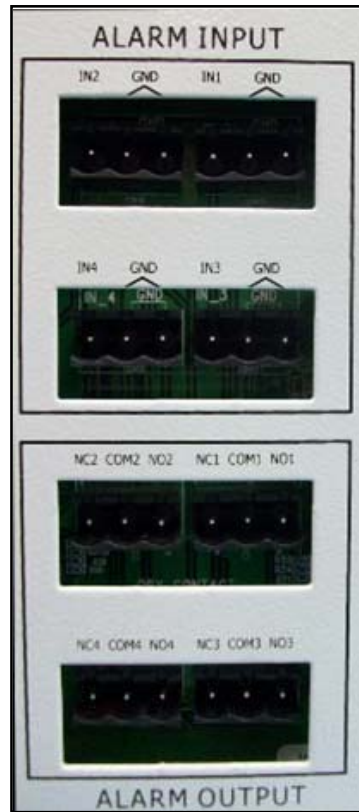

**Figure 4-19. Alarm Interface**

1. With wire cutting tools, prepare the connecting wires.
2. Loosen the screws in each connector.
3. Use the Input Alarm configurations shown in **Table 4-8** and the Output Alarm configurations in **Table 4-9** to determine the wire placement.
4. Slide the bared wires into the slot under the screw and tighten securely.
5. Plug all the alarm connectors into the Alarm Input interface as shown in **Figure 4-20** and **Figure 4-21**.

**Table 4-8. Input Alarm Configuration**

NMS Alarm Status	Alarm	No Alarm
Expanded Alarm 1 (User Defined)	IN1/GND	IN1
Expanded Alarm 2 (User Defined)	IN2/GND	IN2
Expanded Alarm 3 (User Defined)	IN3/GND	IN3
Expanded Alarm 4 (User Defined)	IN4/GND	IN4

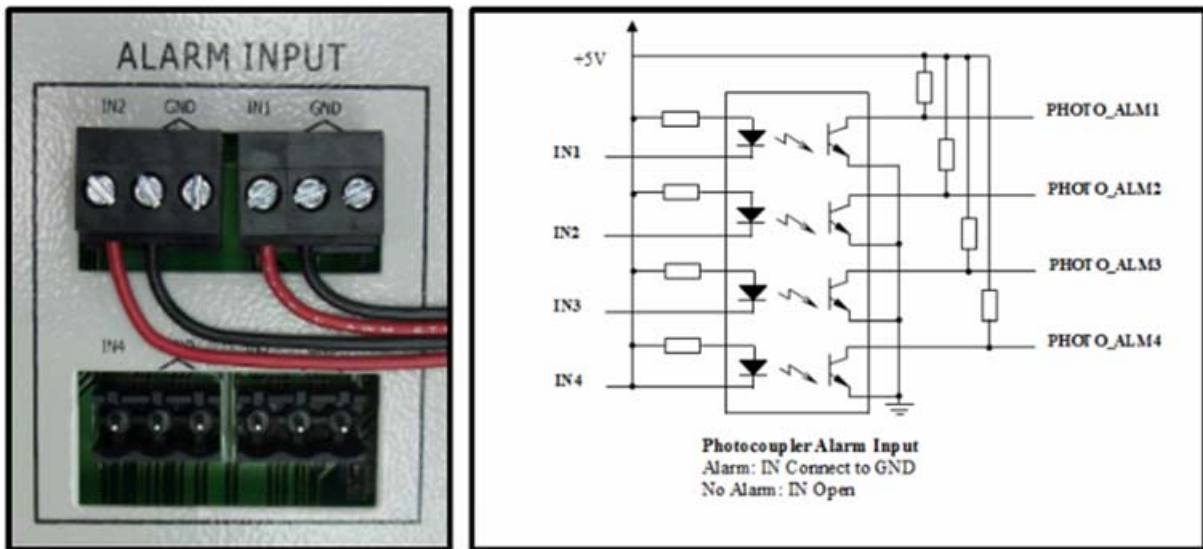

Figure 4-20. Input Alarm Installation (Alarm On)

Table 4-9. Output Alarm Configuration

Alarm Type	On	Off
Major	COM1/NC1	COM1/NO1
Minor	COM2/NC2	COM2/NO2

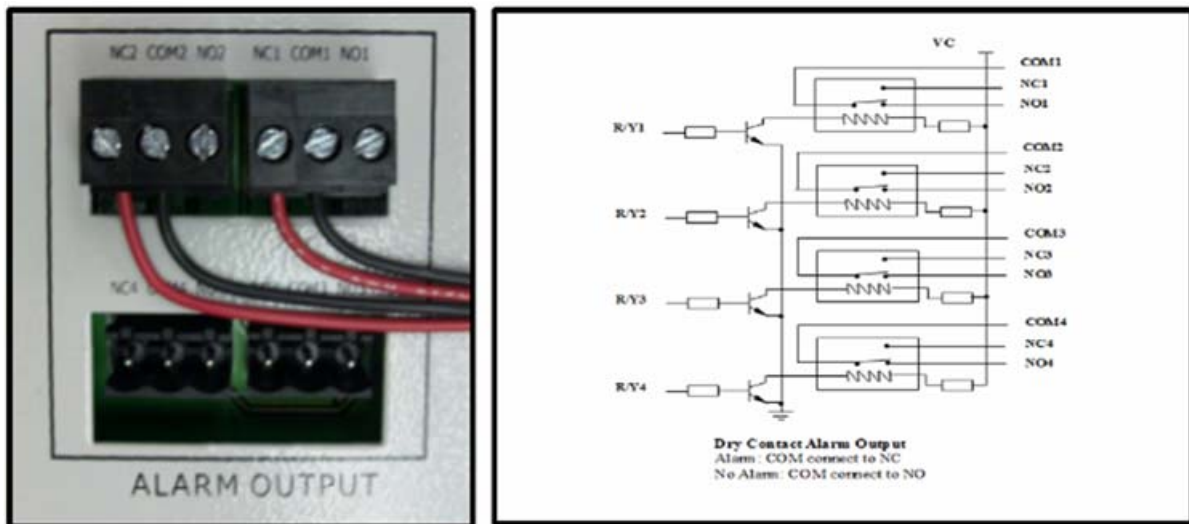

Figure 4-21. Output Alarm Installation (Alarm On)

#### 4.3.4.6 Connect the BIU/FIU Modules

Connect the BIU to the FIU-S with the provided interface cable using the following procedure:

1. Connect one end of the interface cable to the BIU port labeled "Tx1 Out".
2. Connect the other end of the cable to the FIU-S port labeled "Tx1".
3. Connect a second interface cable to the BIU port labeled "Rx4".

4. Connect the other end of the cable to the FIU port labeled "Rx1", **Figure 4-22**.

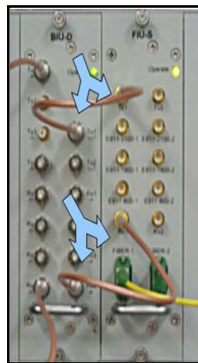

**Figure 4-22. Connect the BIU to the FIU**

For a two BIU and FIU-NS configuration, use the additional provided interface cables and the following procedure:

5. Connect the one end of the interface cable to the FIU-NS port labeled "Tx1".
6. Connect the end of the second interface cable to the FIU-NS port labeled "Tx2".
1. Connect one end of the interface cable to the BIU port labeled "Tx1 Out".
2. Connect the end of the second interface cable to the port labeled "Tx1 Out" of the second BIU.
3. Connect the end of the third interface cable to the FIU-NS port labeled "Rx1".
4. Connect the other end of the fourth interface cable to the FIU-NS port labeled "Rx2".
5. Connect the third interface cable to the BIU port labeled "Rx4".
6. Connect the fourth interface cable to "Rx4" of the second BIU.

#### **4.3.4.7 Optional Equipment Installation**

The POI and Fan, (if ordered) are factory installed. Please verify the POI and Fan are securely connected as shown in **Figure 4-23**.

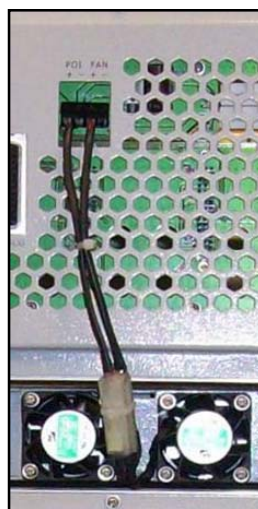

**Figure 4-23 POI and FAN Installation**

#### **4.3.4.8 Connect POI to BIU**

The Point of Interface (POI) is an optional component. The POI is connected to the BIU using the following procedure:

1. Connect one end of a POI interface cable into the BIU port labeled "Tx1 In".
2. Connect the other end of the cable to the POI port labeled "Tx-L".
3. Connect the one end of a POI interface cable into the BIU port labeled "Rx4 Out".
4. Finally, connect the other end of the cable to the POI port labeled "Rx-L".

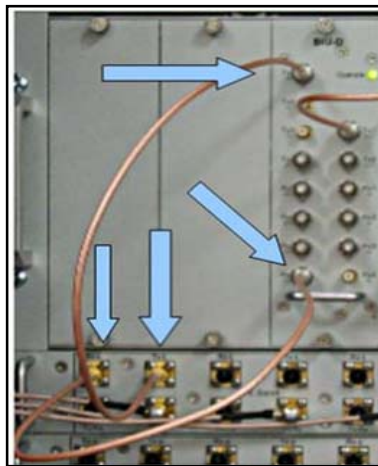

Figure 4-24. POI to BIU Connection

#### **4.3.4.9 Connect the Fiber Optic Cable**

The Fiber optic cable is connected to the FIU module by attaching the cable to the port labeled "Fiber-1" as shown in **Figure 4-25**.

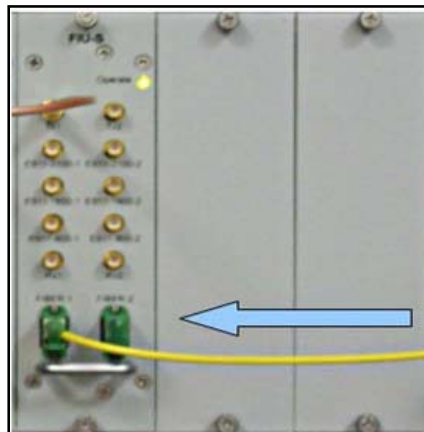

Figure 4-25. Fiber Optic Cable Connection to the FIU Module

### **4.3.5 Host Unit Installation Review**

#### **4.3.5.1 Electrical Installation Review**

**Table 4-10. Host Unit Electrical Installation Check List**

<b>Items</b>	<b>Description</b>
1	Verify that the grounding cable is secure.
2	Confirm that the power cable connection is stable and is neither loose or damaged and that the electrical polarity is correct.
3	Verify that the fiber optic cable is securely connected.
4	Check that all installed cables are securely connected.
5	Confirm that the alarm connectors are securely connected.



### 4.3.6 Troubleshooting

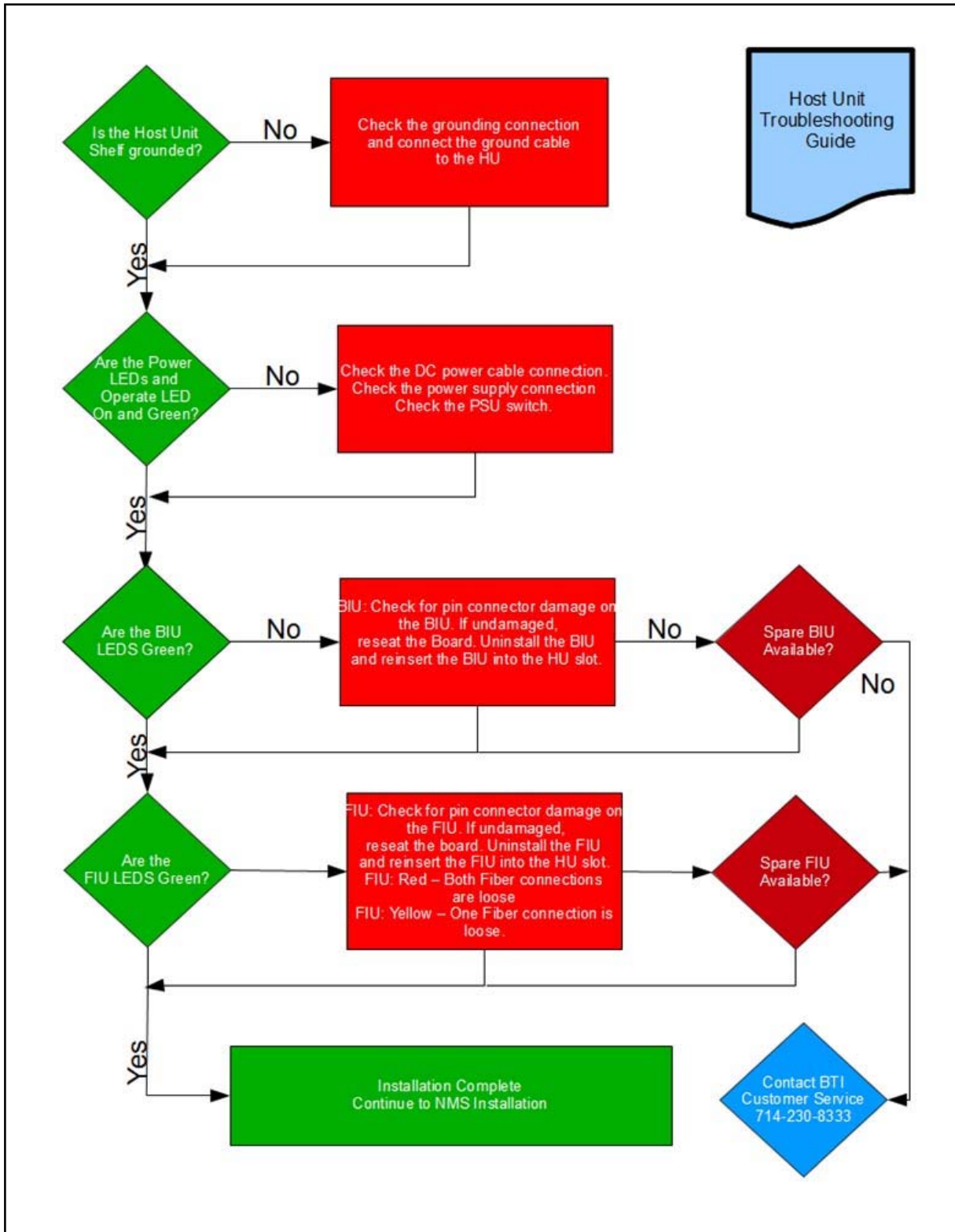

## 4.4 NMS INSTALLATION



**Caution:** Network security may be compromised when accessing external Internet connectivity. The use of established security software is recommended.

The NMS software is pre-installed on the Network Management Server and the NMS server arrives pre-installed in the optional Host Unit cabinet. This section provides instruction for installing the NMS software on a customer laptop or desktop and setting initial software parameters.



Figure 4-26. NMS Server

### 4.4.1 Installation Overview

The installation of the Network Management System consists of the following steps:

Table 4-11. NMS Installation Overview

Step	Operation Type	Operation Action
1	SYSTEM SET-UP	VERIFY SERVER SOFTWARE IS OPERATIONAL
2	SYSTEM SET-UP	INSTALL SYSTEM SOFTWARE ON TO CUSTOMER MONITORING EQUIPMENT
3	SYSTEM SET-UP	LAUNCH NMS SOFTWARE
4	CONFIGURE	CONFIGURE MANAGER ACCOUNT
5	CONFIGURE	SET-UP USER ACCOUNTS
6	CONFIGURE	SOFTWARE SYSTEM PARAMETERS
7	UPDATE/UPGRADE	SOFTWARE/FIRMWARE UPGRADE INSTALL
8	INITIAL SOFTWARE INSTALLATION REVIEW	CONFIRM SOFTWARE SET-UP INSTALLATION, <b>TABLE 4-13 NMS INITIAL SOFTWARE INSTALLATION CHECKLIST</b>
9	UPGRADE INSTALLATION REVIEW	CONFIRM FIRMWARE UPDATE AND SOFTWARE UPGRADE INSTALLATION, <b>TABLE 4-14 NMS UPGRADE SOFTWARE INSTALLATION CHECKLIST</b>
10	TROUBLESHOOTING	INSTALLATION TROUBLESHOOTING GUIDE

### 4.4.2 Installation Hardware and Tools

The NMS server is shipped pre-installed in the optional Host Unit cabinet. **Table 4-12** lists the accessories provided by the manufacturer. Additional accessories may be needed, depending on the site requirements, and may be ordered through Customer Service (Section 6).

Table 4-12. NMS Cables and Accessories

NMS ACCESSORY	Quantity	Received
SOFTWARE CD-ROM	1	

NMS ACCESSORY	Quantity	Received
AC POWER CABLE	1	

The following is a list of tools and any additional materials required for NMS software installation:

- Laptop, Desktop PC and/or Terminal
- Crossover Cable
- Hub and/or Router

### 4.4.3 Unpacking And Inspection

This section provides the instructions for receiving the equipment shipment and verifying that no damage has occurred during shipping. The NMS software is pre-installed on the server which is shipped with the following:

- Optional cabinet with NMS server and Host Unit installed as shown in **Figure 4-27**.
- Installation cables and accessories as described in **Table 4-12, Section 4.4.2**.

Use the following procedure to unpack and inspect the NMS server and accessories:

1. Open the shipping packet and carefully unpack the cabinet from the protective packing material.
2. Verify receipt of accessories using **Table 4-12**
3. Check the server for visual damage. If there is any damage, contact BTI (Section 6) for further instructions including an RMA, if necessary.

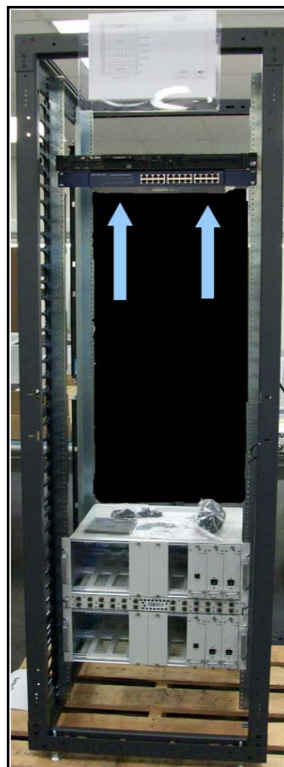
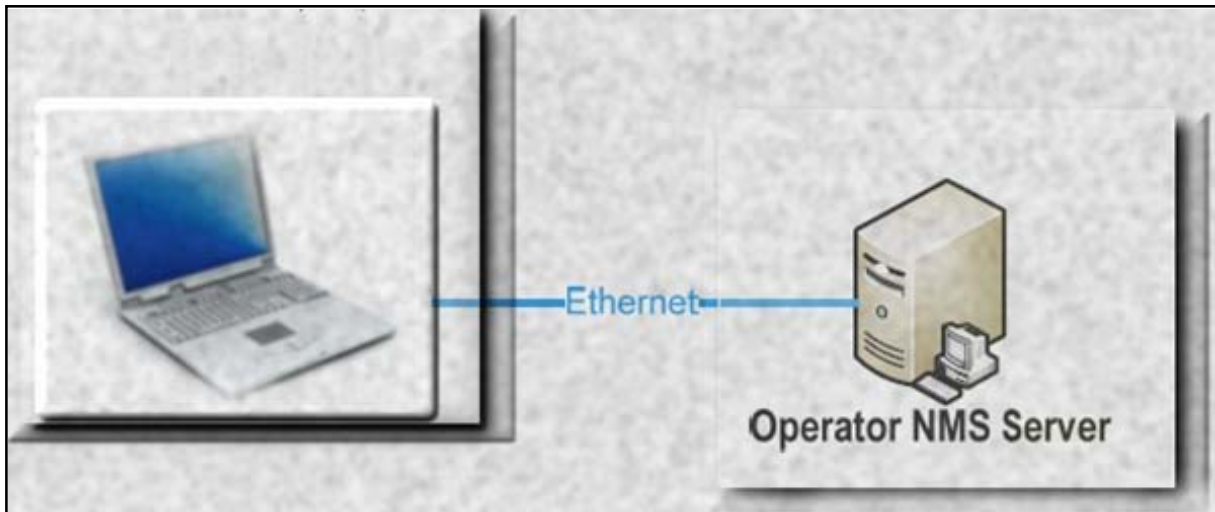

Figure 4-27. NMS Server

### 4.4.4 Verify Server software

1. Connect the laptop, PC or terminal to the server through the hub using a crossover cable, **Figure 4-28**. The monitoring device may also be plugged directly into the server with a crossover cable.



**Figure 4-28. Connecting the Monitoring Device to the Server**

2. Locate the NMS icon on the screen of the monitoring device, **Figure 4-29**.

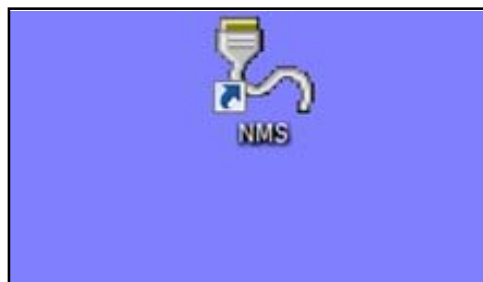

**Figure 4-29. Locate NMS Icon**

## 4.4.5 Initial System Setup

### 4.4.5.1 CD-ROM Install

The CD-ROM install is used to install NMS on to a Laptop or Desktop Computer. Use the following procedure to install the application on to the computer:

1. Open the CD drive on the machine.
2. Place the CD into the drive and close the drive.
3. The CD will begin the install wizard, **Figure 4-30**.
4. The wizard copies the files to the %ProgramFiles% folder. The default destination directory may be changed, if desired.



Figure 4-30. DAS Setup Wizard

#### 4.4.5.2 Launch NMS

1. After copying the files, the Wizard will ask to launch NMS, **Figure 4-31**.
2. Select Yes.
3. The Wizard simultaneously places a shortcut on to the desktop of the computer as shown in **Figure 4-**



32. Double clicking on the NMS icon on the desktop also launches the NMS Login screen.

Figure 4-31. NMS Launch from Wizard Installation



Figure 4-32. NMS Desktop Shortcut



*NOTE: Occasionally, there are compatibility problems that cause a configuration conflict when setting up the NMS. Follow the steps shown in the Troubleshooting Guide. If this does not resolve the issue, contact Customer Service (Section 6).*

4. Verify that the *Advance* box is checked and then click in the password field, **Figure 4-33**.
5. Enter the following default password: 1
6. Click on *OK*. The NMS Command Console is then launched.



Figure 4-33. NMS Login Screen

## 4.4.6 Initial Start-up Configuration

Once NMS is installed on the machine, the command console or main screen is used to navigate through various NMS menus to configure both the software system parameters and the DAS system parameters. This section covers the software system parameters needed to set-up an initial install.

Main access to the NMS software configuration is through the *System(S)* drop down on the Menu bar as shown in **Figure 4-34**. User accounts may also be accessed through the User Icon on the Command toolbar as shown in **Figure 4-35**. The software system configuration includes the ability to access the

following functions:

- Access and manage User Accounts and passwords (Add/Modify/Delete)
- Modify parameter defaults.

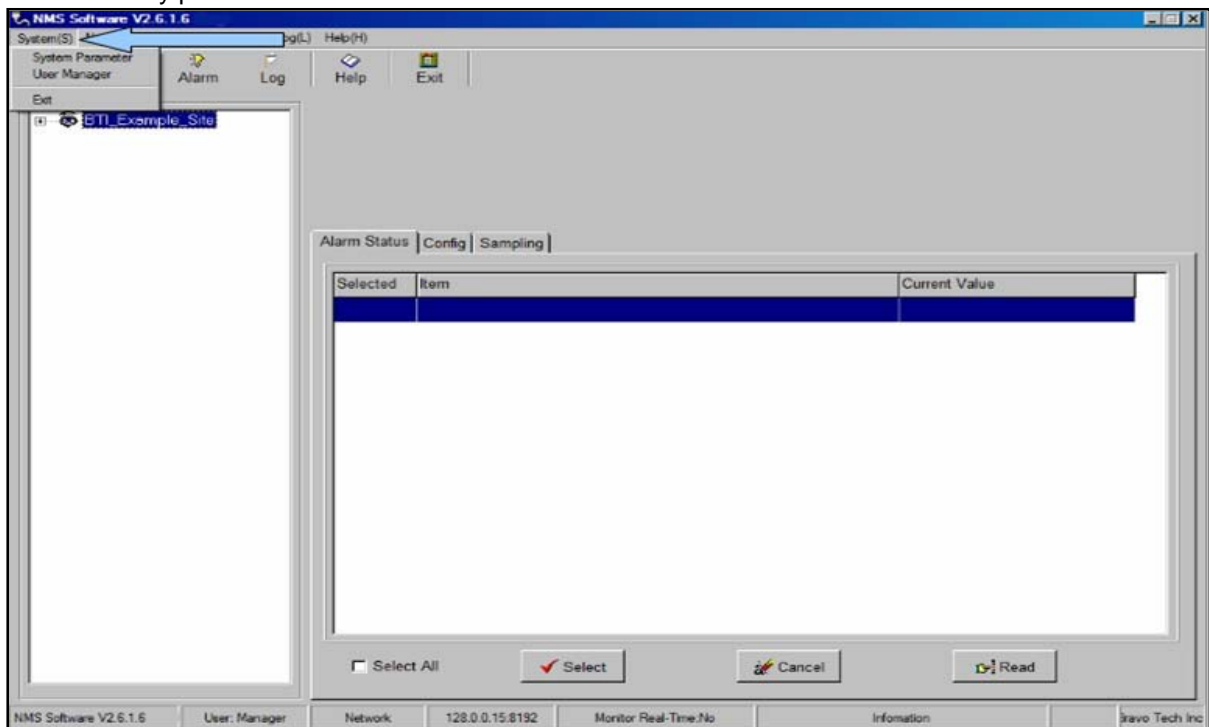

Figure 4-34. System (S) Drop Down Menu

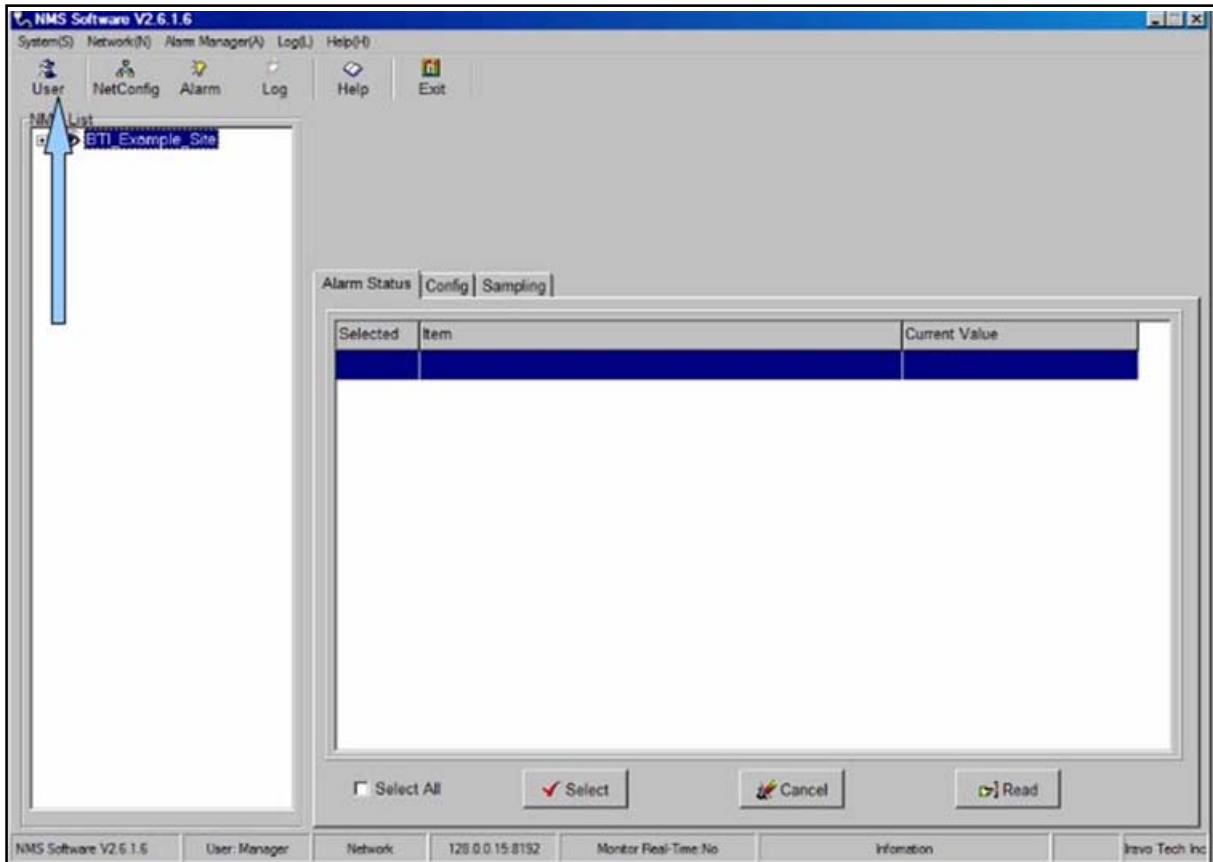

Figure 4-35. User Account Icon

#### 4.4.6.1 Modify Default Accounts

The NMS User Manager comes with two default entries shown in the User list. For security reasons, changing the default manager account and password is highly recommended. The default User account may also be modified by overwriting the default information. The following procedure details the steps necessary to change the default accounts:

1. Using either the System(S), **Figure 4-34** or the User icon, **Figure 4-35**, access the User Manager screen, **Figure 4-36**.



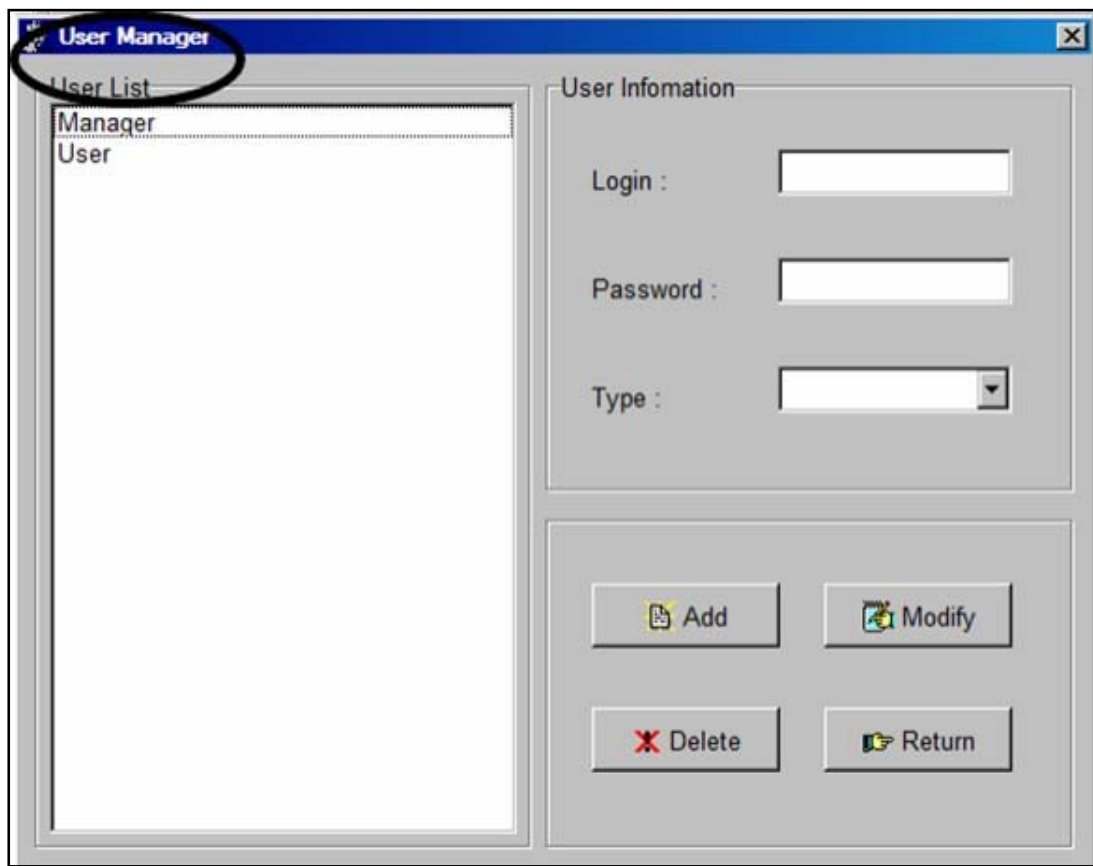
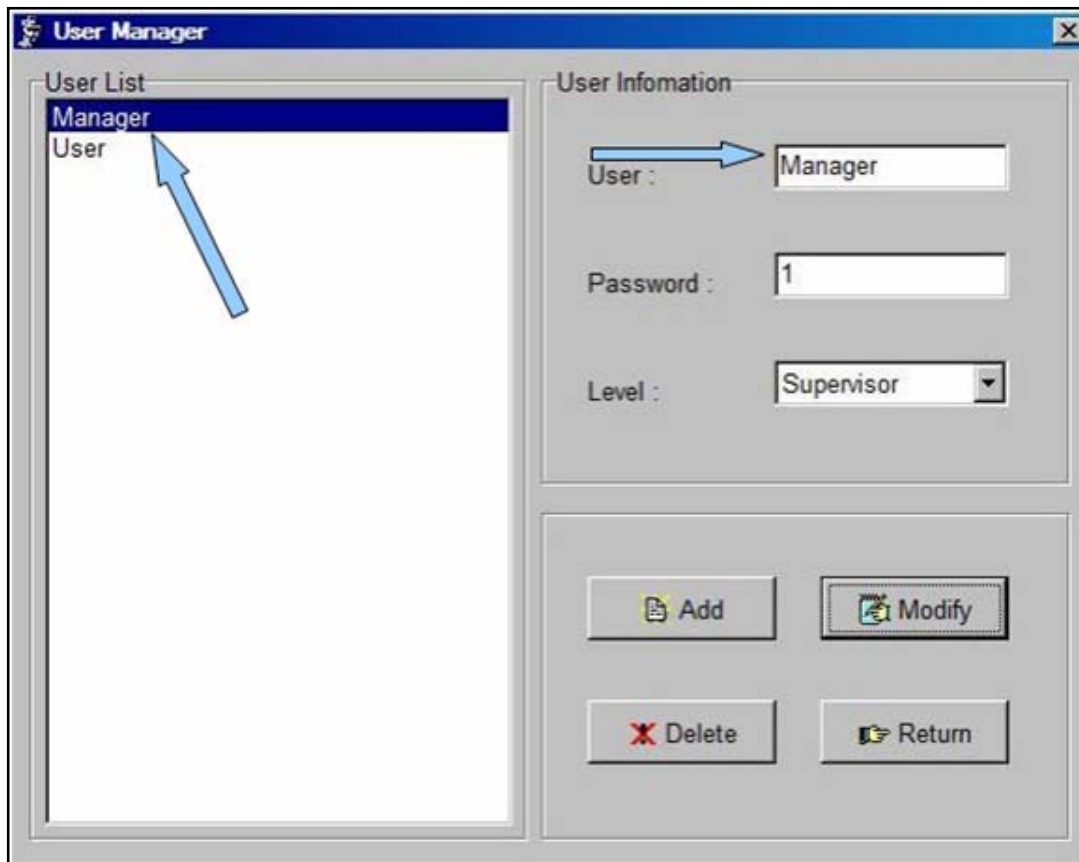

Figure 4-36. User Manager Screen

2. Select Manager in the User List, **Figure 4-37** to see the default information.

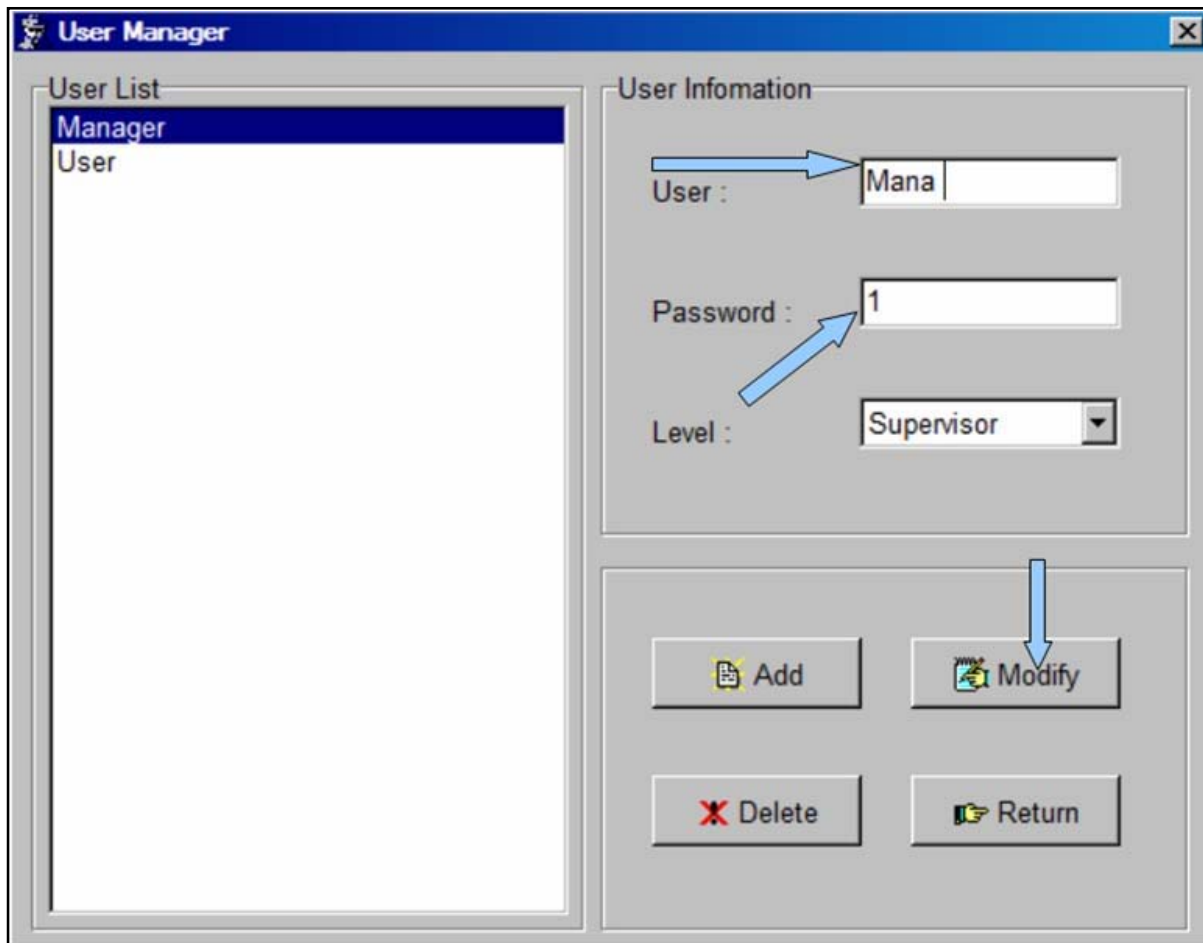

**Figure 4-37. Manager Default Information**

3. Delete the default entries, **Figure 4-38** and enter the new user name and password.



*Note: There is a limit of 20 Alpha-Numeric characters for both User name and password entries. User names are selectable from the Login screen drop down menu, once entered into the system. Passwords are case sensitive.*



**Figure 4-38. Edit Default Entries**

4. Click *Modify* to update the *User* and *Password*.
5. Click *Return* to return to the NMS Command Console or continue to add or update User Accounts.

#### **4.4.6.2 Set-up New User Accounts**

Adding a New User is easily managed through the User Manager screen. Access the User Manager screen, then use the following procedure to add Users of various levels:

1. Currently, there are two levels available for User Accounts. Once the User Manager screen is up, select the User level, as shown in **Figure 4-39**.
  - **Supervisor:** This level acts as an administrator for the Network System. This level can make edits and set custom features.
  - **Observer:** This level is a monitoring functionality only. This level is most commonly used for users who will monitor the system and review alarm logs. At the Observer level, a user may only: modify their user name and password and; view, save and print Alarm information.

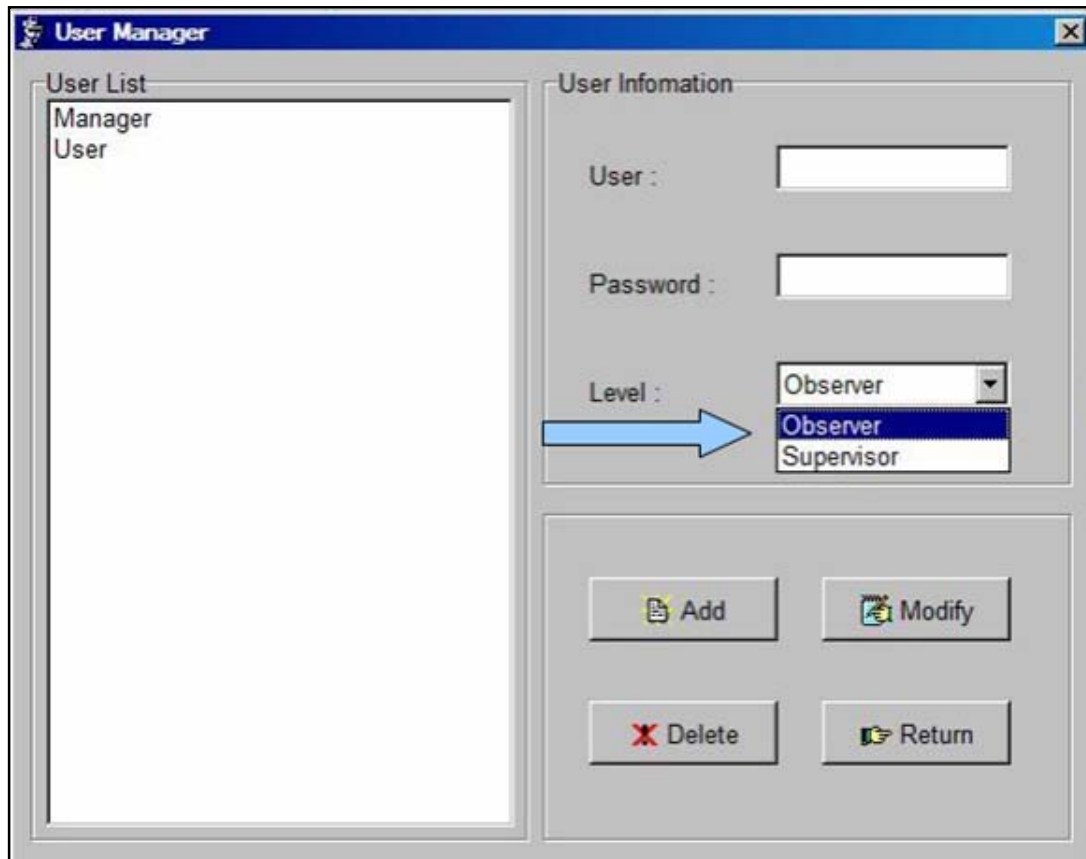

Figure 4-39. Select a User Level

2. Enter a user name and password, **Figure 4-40**. Then click *Add*.

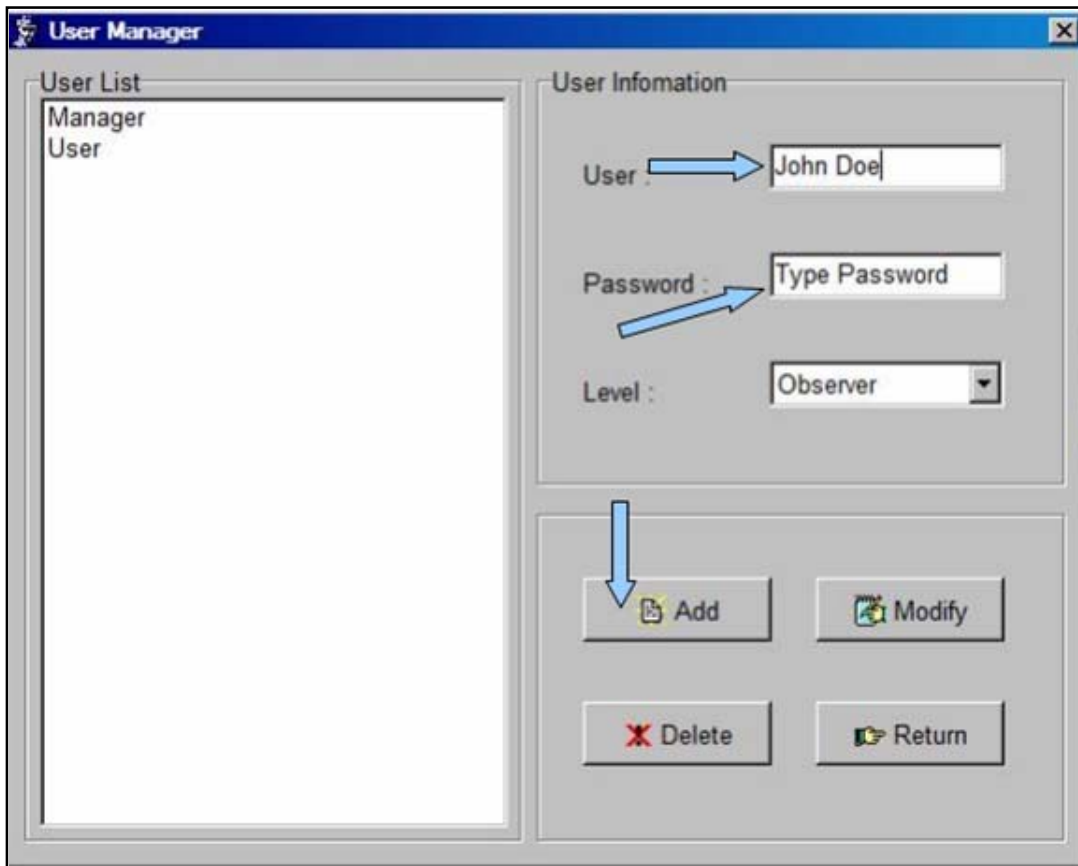

Figure 4-40. Enter User name and Password



*Note: There is a limit of 20 Alpha-Numeric characters for both User name and password entries. User names are selectable from the Login screen drop down menu, once entered into the system. Passwords are case sensitive.*

3. Additional detailed information for managing User accounts, including deleting and modifying User accounts is contained in the NMS User Manual.

#### 4.4.6.3 Configure Software Parameters

The NMS system software parameter defaults allow the user to focus less on configuring the software system, **Figure 4-41**, and more on the critical functionality for the DAS system.

Detailed parameter information is available in the NMS User Manual.

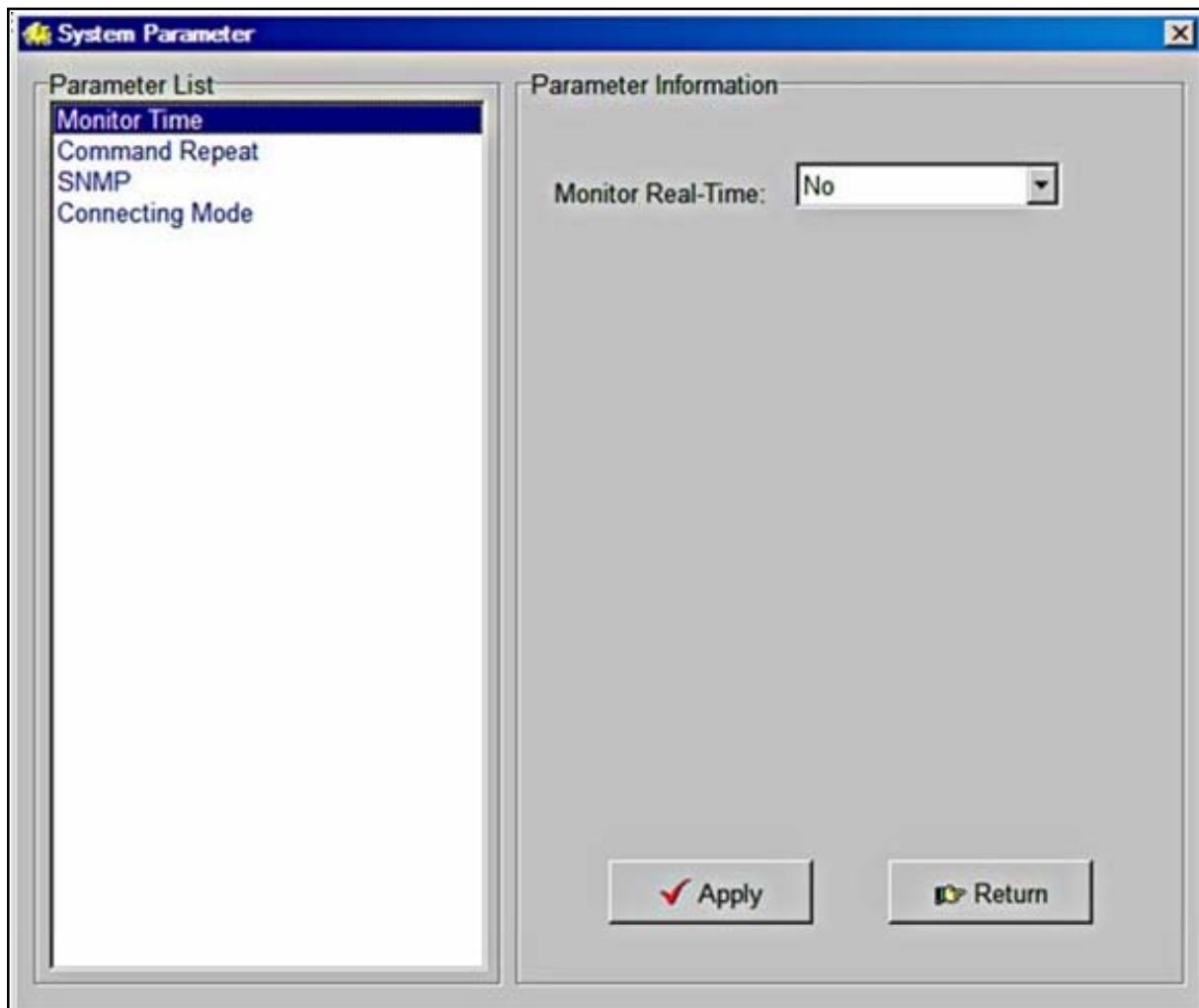

Figure 4-41. System Parameter Screen

## 4.4.7 Firmware Update

DAS components periodically require firmware updates. The following list of components may require periodic firmware updates:

- BIU
- FIU
- PA
- RCU
- Remote Unit

A notification email is sent with the firmware update attached as a file to the email. The following procedures detail the firmware update process:

1. Verify the email is genuine and the file attachment is safe for download. The sent file will be named in the following manner and have a file extension of .s:

DAS8345\_[Component]\_[Version].s

2. Download the attached file to any chosen folder or the desktop. Note the folder name, if saved to a designated folder.

3. Log into the NMS System.
4. Click on *NetConfig*
5. Using the *RemoteSoftwareDownload* interface, **Figure 4-42**, Locate the file by clicking on the browse button.

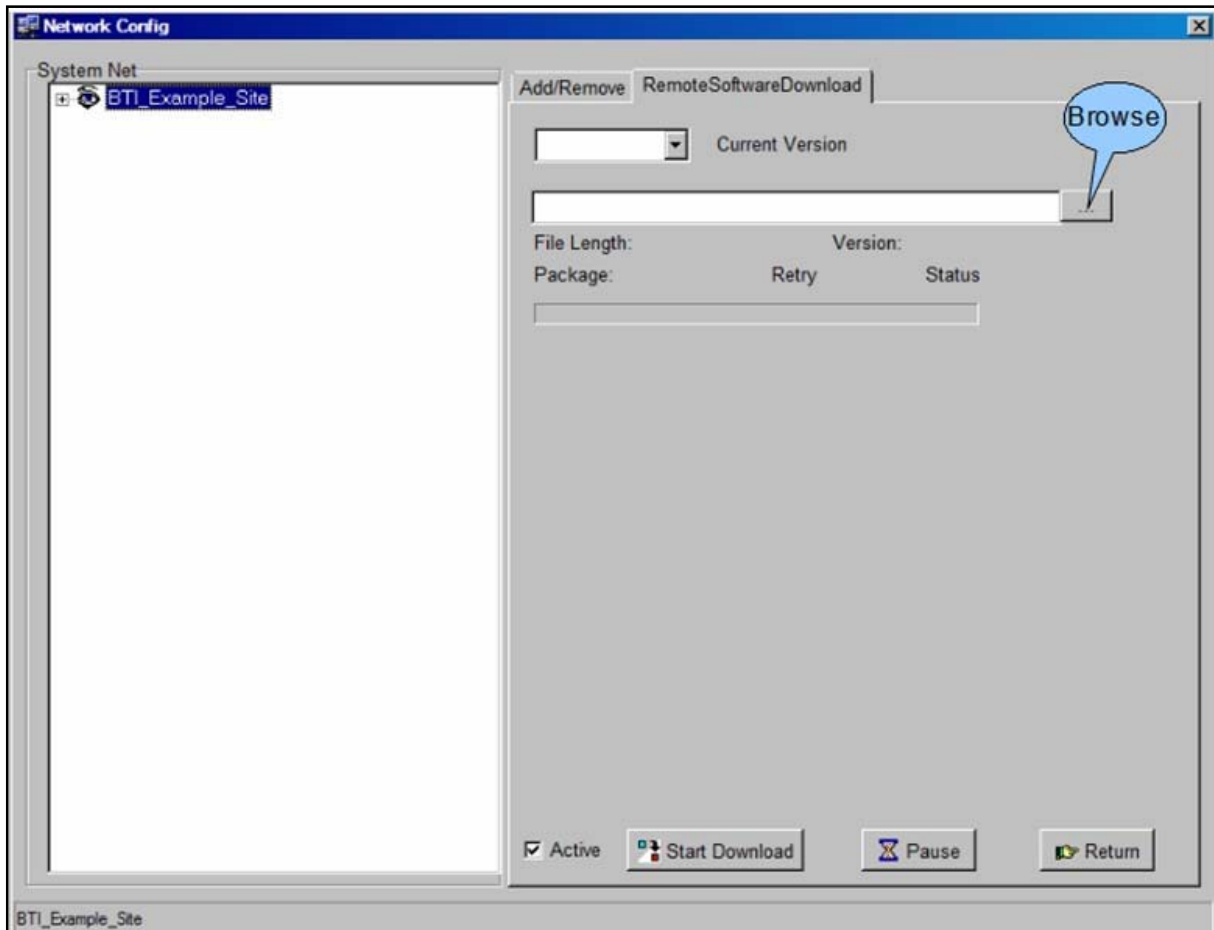

**Figure 4-42. Remote Software Download Screen**

6. Click *Start Download*. The firmware update may be paused if needed by clicking the *Pause* button.
7. Once the download is complete, click *Return*.

## 4.4.8 Software Upgrade Installation

### 4.4.8.1 CD-ROM Install

The CD-ROM Upgrade install is a quick and simple installation. Use the following procedure to install the application on to the computer:

1. Check that no instance of NMS is running.
2. Open the CD drive on the machine.
3. Place the CD into the drive and close the drive.
4. The CD will begin the install wizard and ask if the user would like to overwrite the older NMS version, **Figure 4-43**.

5. Select Yes.

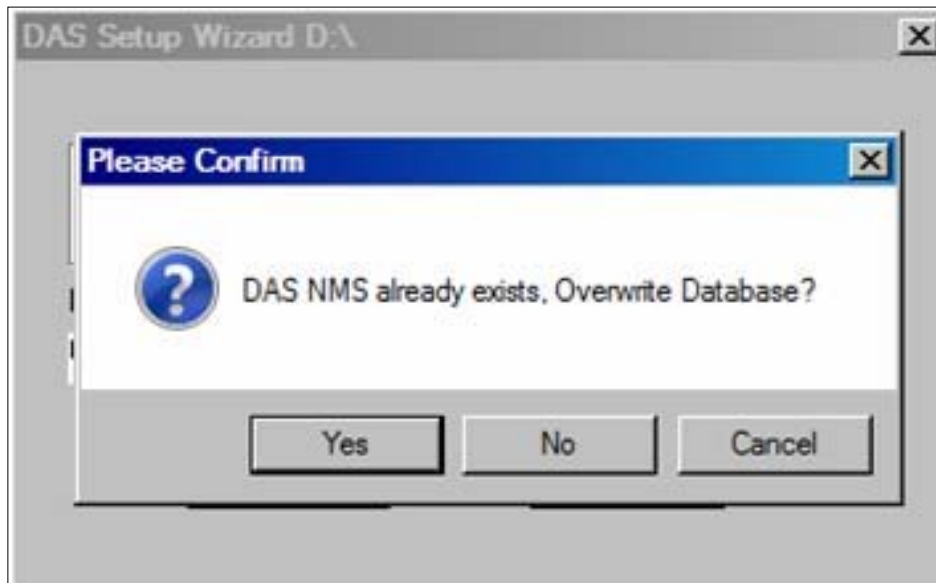

Figure 4-43. Replace NMS File

5. An error dialog box will appear, **Figure 4-44**, if the older version of NMS is open and running.
6. Close NMS and click *Try Again*.

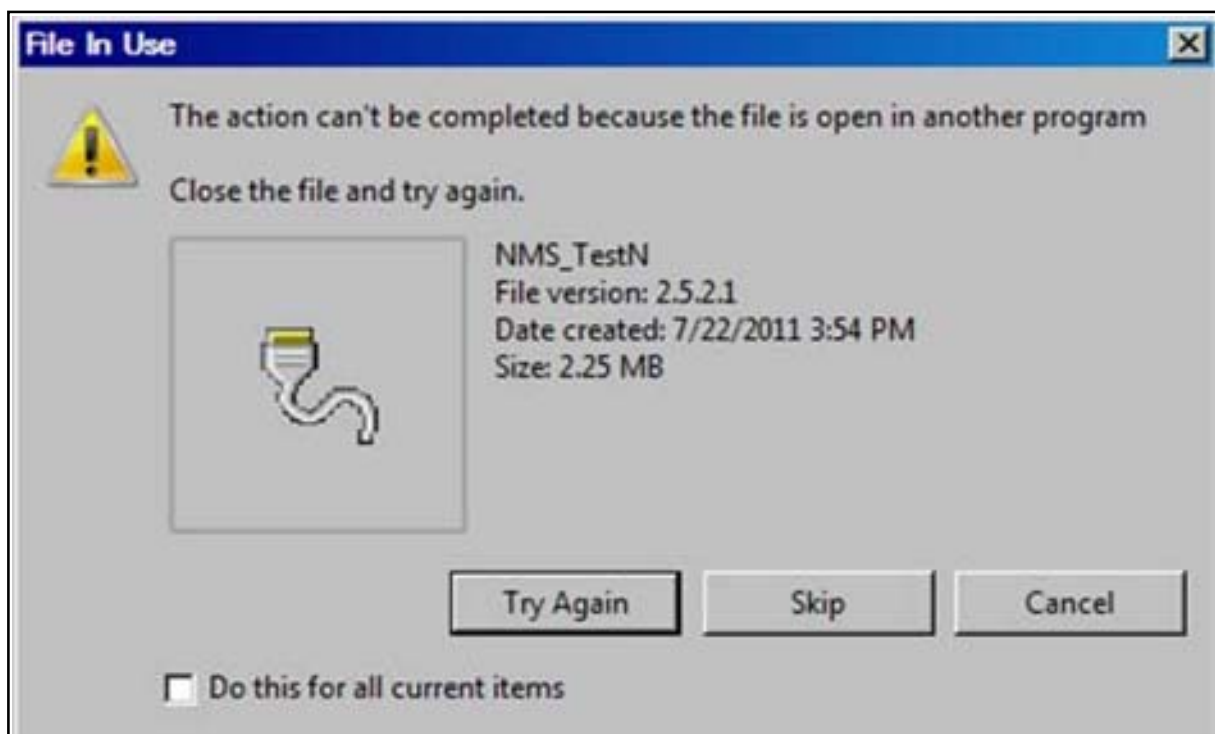

Figure 4-44. NMS Update Fail Error Box

## 4.4.9 NMS Upgrade Installation Review



**Table 4-13. NMS Initial Installation Checklist**

<b>Items</b>	<b>Description</b>
1	Verify that the CD is undamaged and the server software is installed.
2	Confirm that the version number once the set-up Wizard launches NMS.
3	Verify that the shortcut launches the NMS Login.
4	Check that the default Manager Account and password have been updated.
5	Confirm that new User accounts and passwords have been added.

**Table 4-14. NMS Firmware Update and Software Upgrade Checklist**

<b>Items</b>	<b>Description</b>
1	Verify that the email and attachment. are genuine.
2	Confirm that the firmware update is downloaded to the appropriate folder on the computer.
3	Verify that firmware update was complete from the <i>RemoteSoftwareDownload</i> interface.
4	Confirm that no instance of NMS is running before beginning Upgrade installation.
5	Check the version number to verify upgrade once the set-up Wizard has launched NMS.

### 4.4.10 Troubleshooting

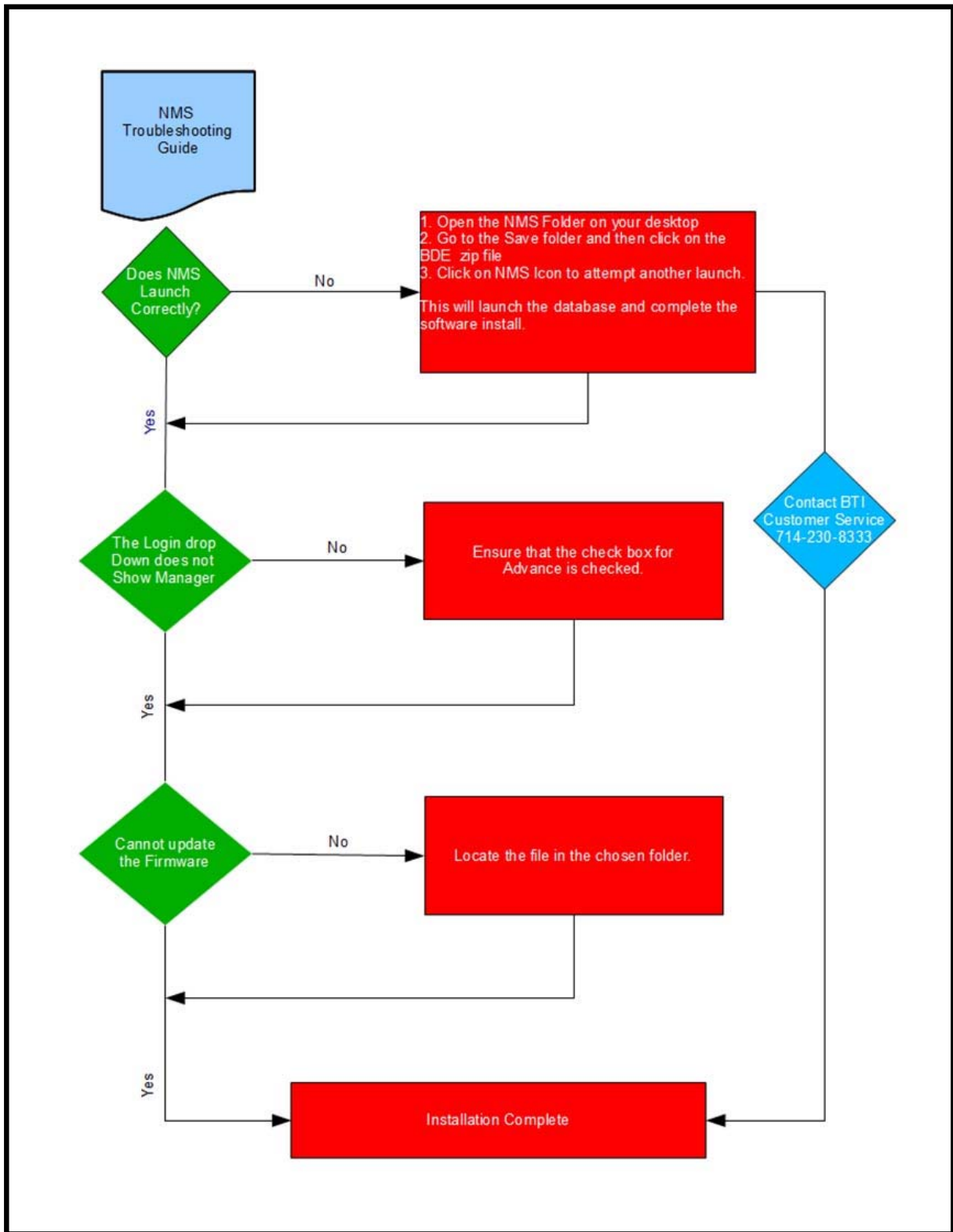

## 5 mBSC DAS SYSTEM START-UP

When the system component installations are complete, the system must be configured. Please refer to the applicable System Operation and User Manual for detailed system configurations, operations, and troubleshooting/test procedures

### 5.1 SYSTEM COMMUNICATION

Once the components have been installed, the system should be activated by establishing communication through the Host Unit and configuring the system to the network through the NMS.

#### 5.1.1 Establishing a Host Unit communication

The Host Unit hardware default IP address must be updated with the customer's network IP address. This is accomplished by first establishing a communication link, setting up the initial base system and configuring the IP Address parameter. Use the following procedure to establish communication with the Host Unit :

1. Connect the NMS installed Laptop ethernet port to the RCU front ethernet port with a cross or null modem cable.
2. From the Laptop, click the Start Button, then Settings and Network Connections, **Figure 5-1**.

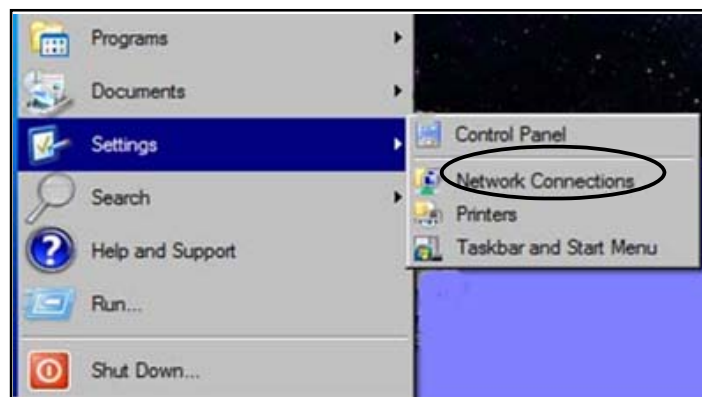

**Figure 5-1. Open Network Connections**

3. Select the LAN Icon and click on *File* then *Properties*, **Figure 5-2**.

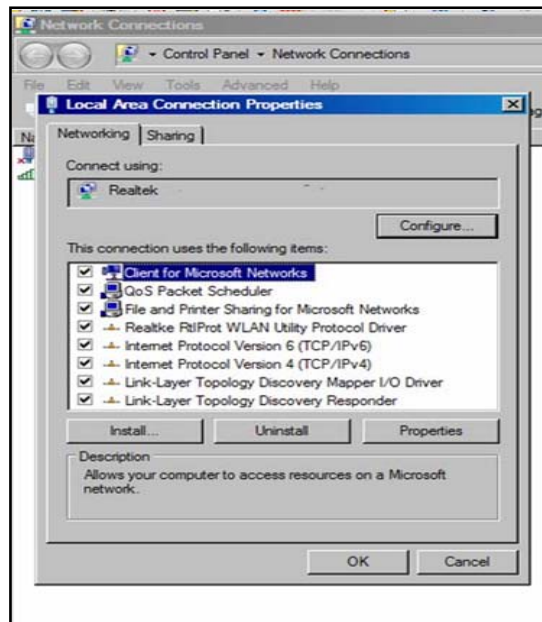
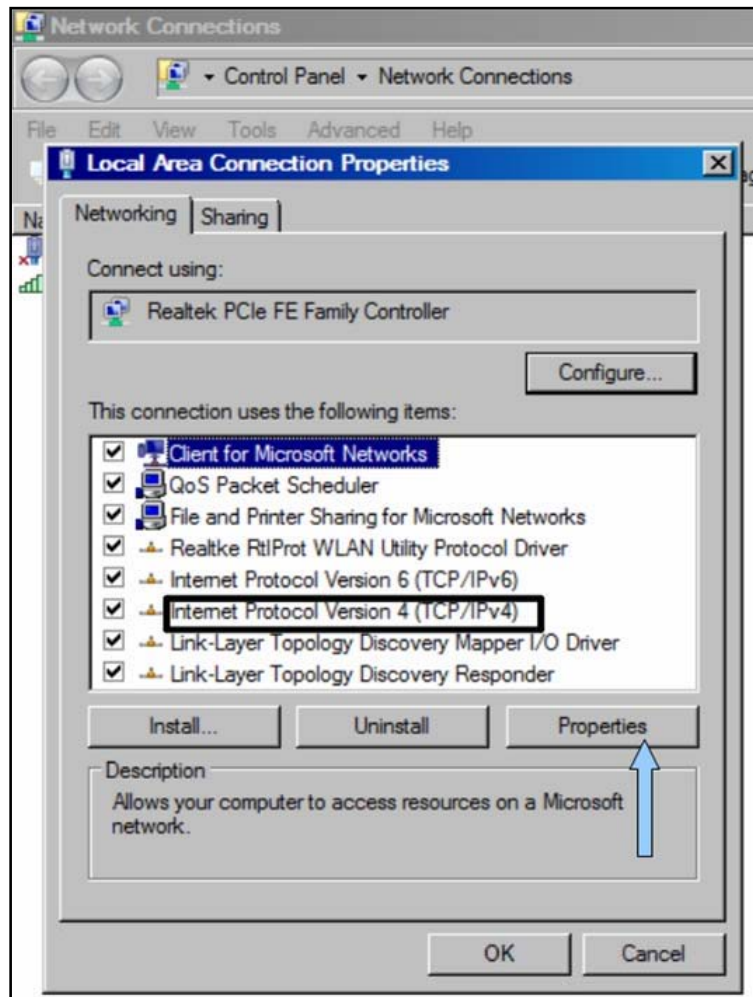

Figure 5-2. LAN Properties

4. Click on Internet Version Protocol (TCP/IPv4) and then click on Properties, **Figure 5-3**.



**Figure 5-3. Select Internet Protocol Version 4**

5. Click on the second option, *Use the Following IP Address;* **Figure 5-4**, and manually enter the IP Address: 128.0.2.30. The Subnet mask will automatically default to 255.255.0.0.

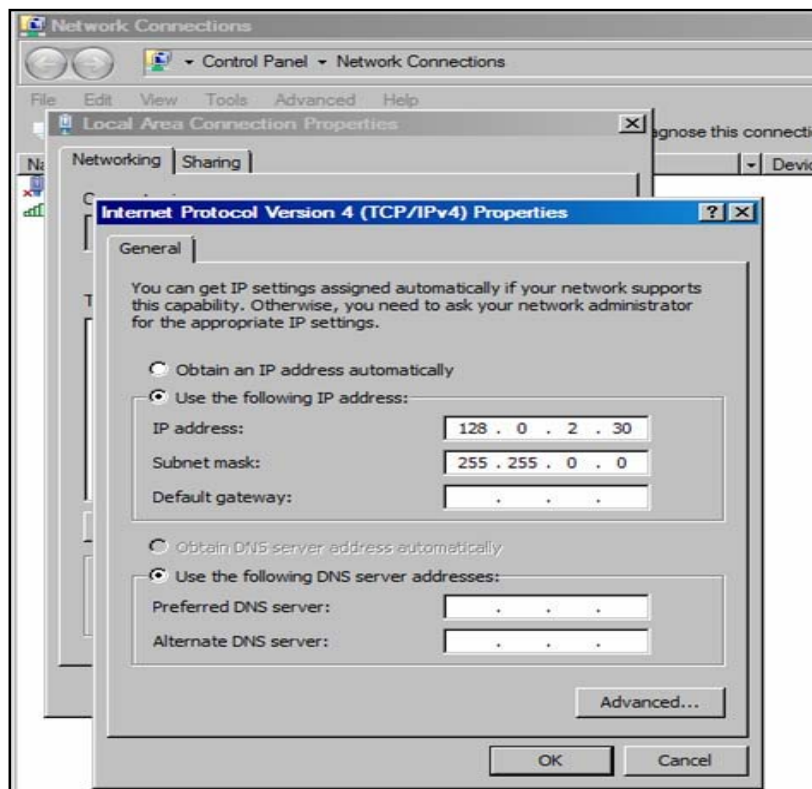

Figure 5-4. Manually Enter the IP Address

6. Click OK.

## 5.2 INITIAL NETWORK CONFIGURATION

This section details the initial functions necessary for a basic system activation through the NMS. Access to the DAS system configuration is through the *Network(N)* menu bar drop-down or the Net Config Command bar button, **Figure 5-5**. The DAS *Network(N)* drop-down includes the ability to access the following functions:

- Add/Modify/Delete Sites
- Add/Modify/Delete the Host Unit(s)
- Add/Modify/Delete the Remote Unit(s)

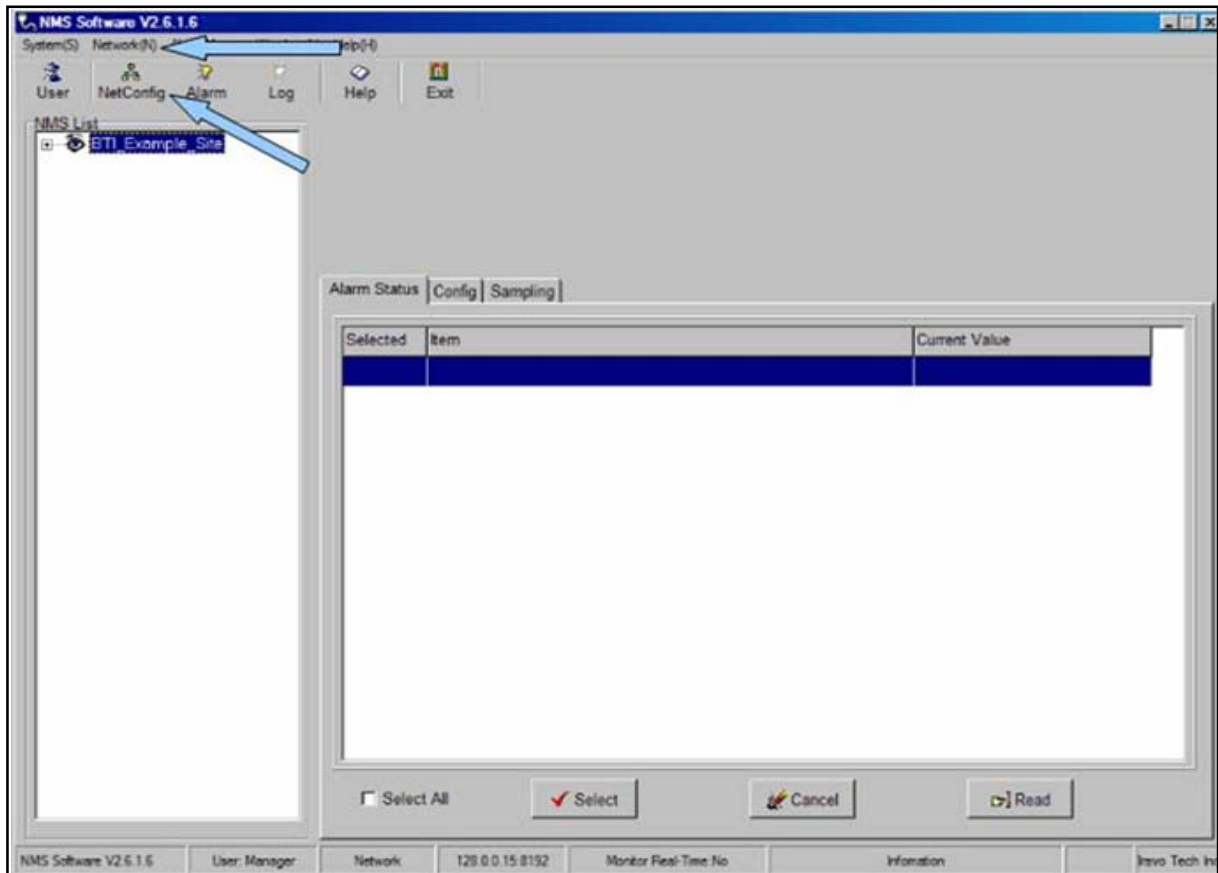

Figure 5-5. Accessing the Network Configuration screen



*The NMS software provides an example configuration as shown in **Figures 5-5 and 5-6**. The example may be deleted or the example information may be overwritten with customer specific information and then saved by clicking the **Modify** button. For the purposes of this installation manual, the example has been deleted to provide the most accurate details.*

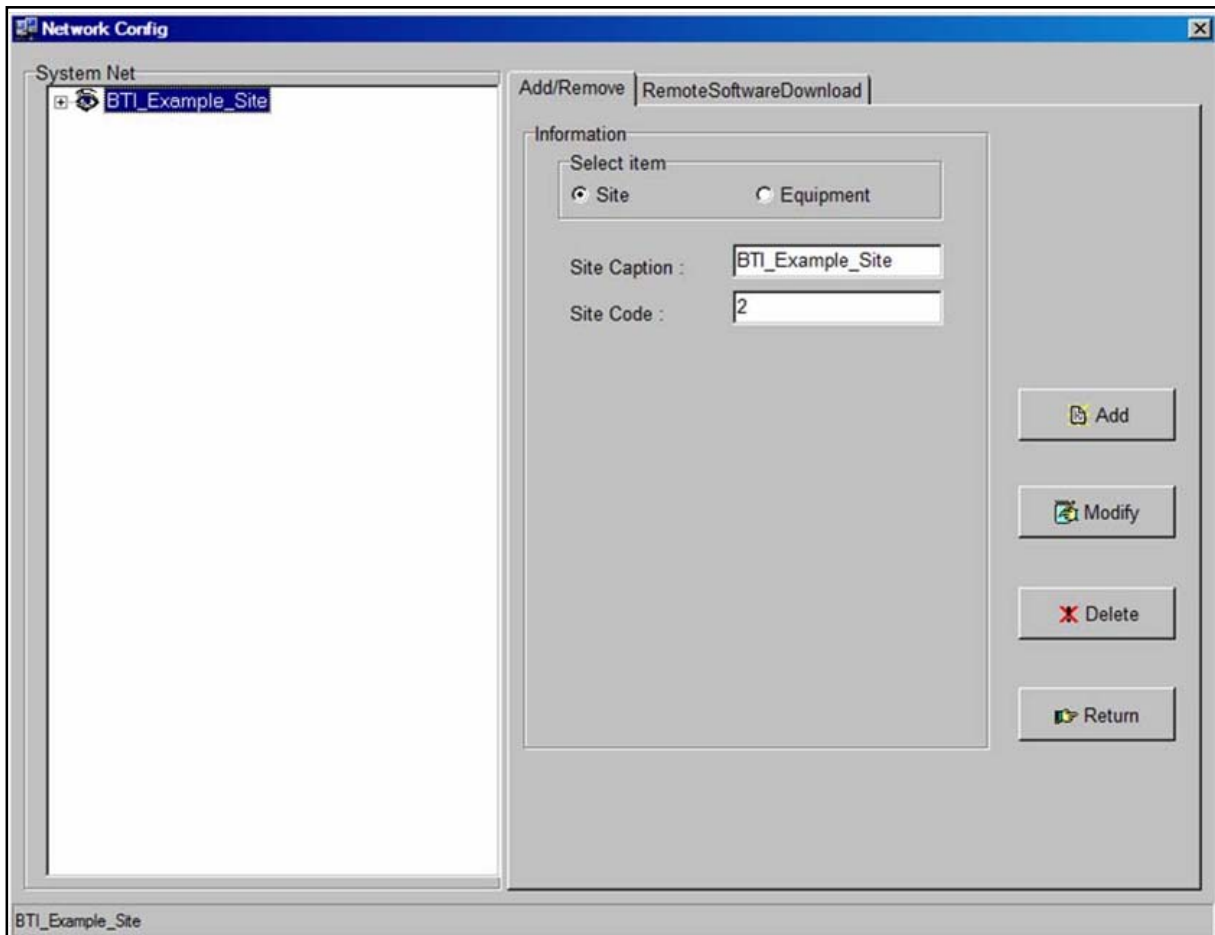

Figure 5-6. BTI Example System Configuration

### 5.2.1 Add a Site

The highest level of system configuration is defined by adding a Site Caption and a Site Code. The alphanumeric text fields accept any user-defined descriptive name (30 alpha-numeric character limit) and site code (1 through 9999 numeric limit). The following steps are used to add the Site Caption and Site code:

1. Access the *Network Config* screen, **Figure 5-5**, via the NetConfig Command bar button or the *Network(N)* menu drop-down.
2. Click on the *Site* button in the *Select Information* field, **Figure 5-7**.
3. Enter the Site name and the Site code. The example, BTI\_Example\_Cypress\_Site is shown in **Figure 5-8**.
4. Click *Add* to save the Site Caption and Site Code.



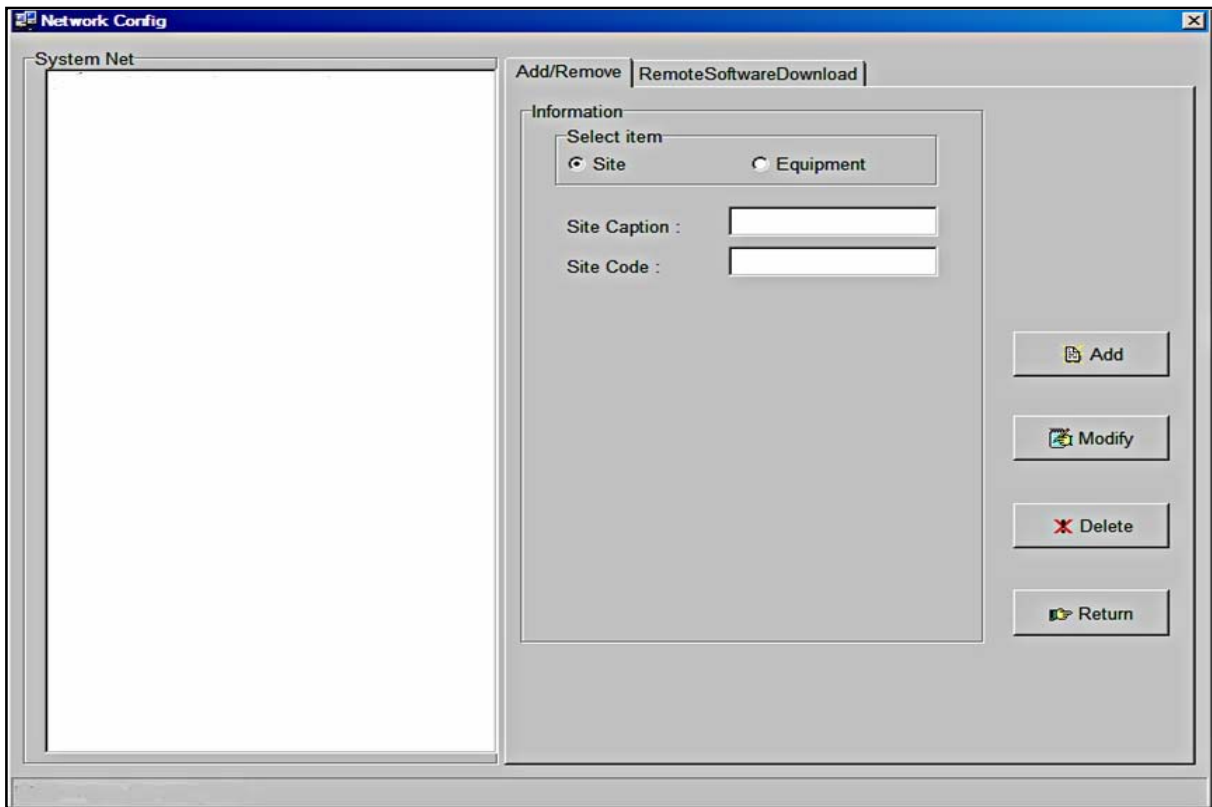

Figure 5-7. Add a Site

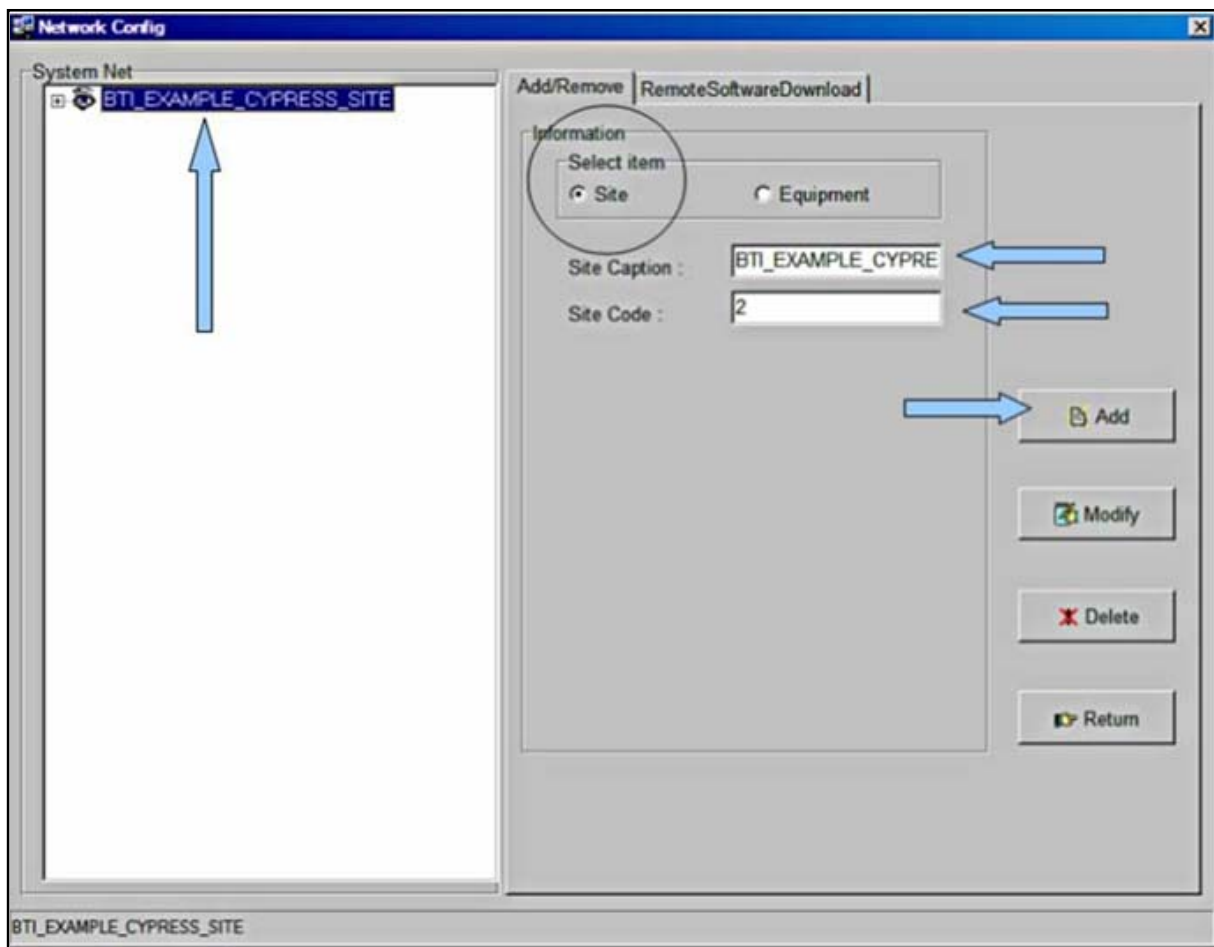
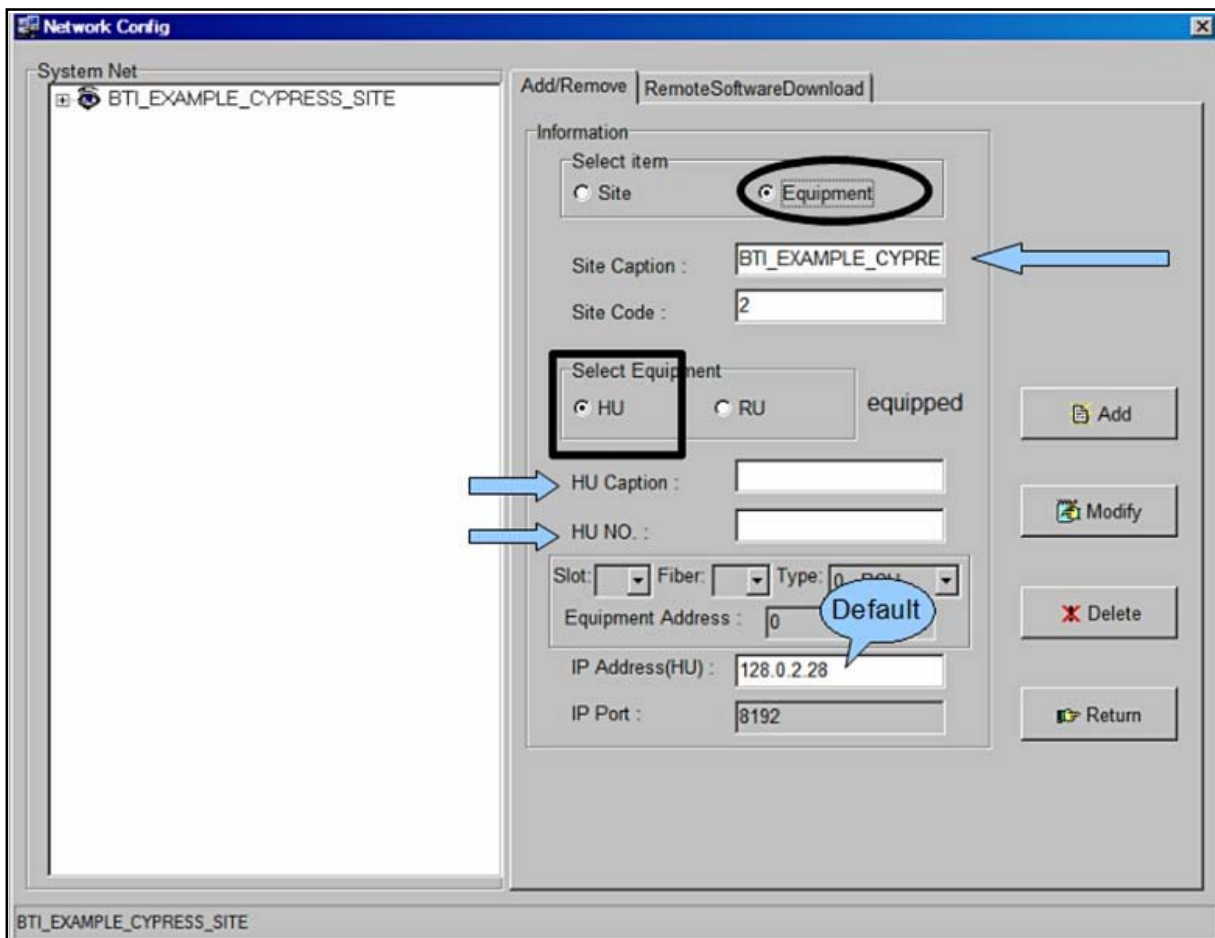

Figure 5-8 Adding a Site

## 5.2.2 Add a Host Unit

Once the Site Caption and Site Code have been configured, the Host Unit should be added to the system. The alpha-numeric text fields accept any user-defined descriptive *HU Caption* (20 alpha-numeric character limit) and *HU No.* (1 through 9999 numeric limit). The following steps provide the Host Unit configuration:

1. Click on *Equipment* to bring up the new information section for the DAS System equipment.
2. Click on *HU* in the *Select Equipment* section. Verify that the Site Caption and Site Code are correct for the Host Unit being added.
3. Add the customer designated Host Unit Caption and Host Unit No. as shown in **Figure 5-9**.



**Figure 5-9. Adding a Host Unit**

4. Verify that all changes have been correctly entered and click *Add*, **Figure 5-10**.

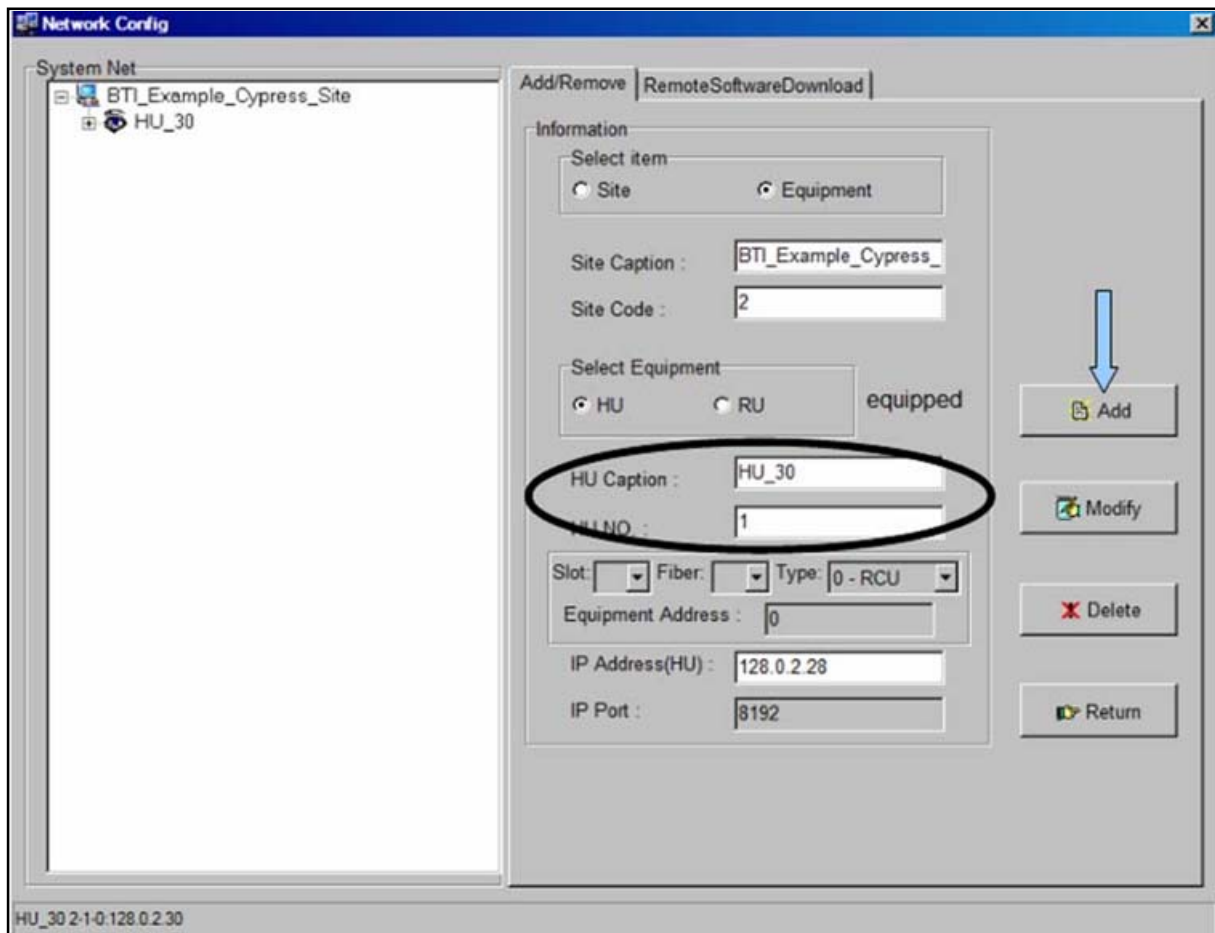

Figure 5-10. Configured Host Unit

### 5.2.3 Configuring the Host Unit Hardware Card

Once the Host Unit has been added to the system, the IP address for the Host Unit must be changed from the default to the designated network IP address in the Host Unit Hardware Card. Configuring the IP Address is done from the Main Command Screen. The following procedures outline the steps necessary to change the Host Unit IP Address:

1. From the Main Command Screen, Select the added HU.
2. Select the RCU Module, **Figure 5-11**.
3. Select Config.

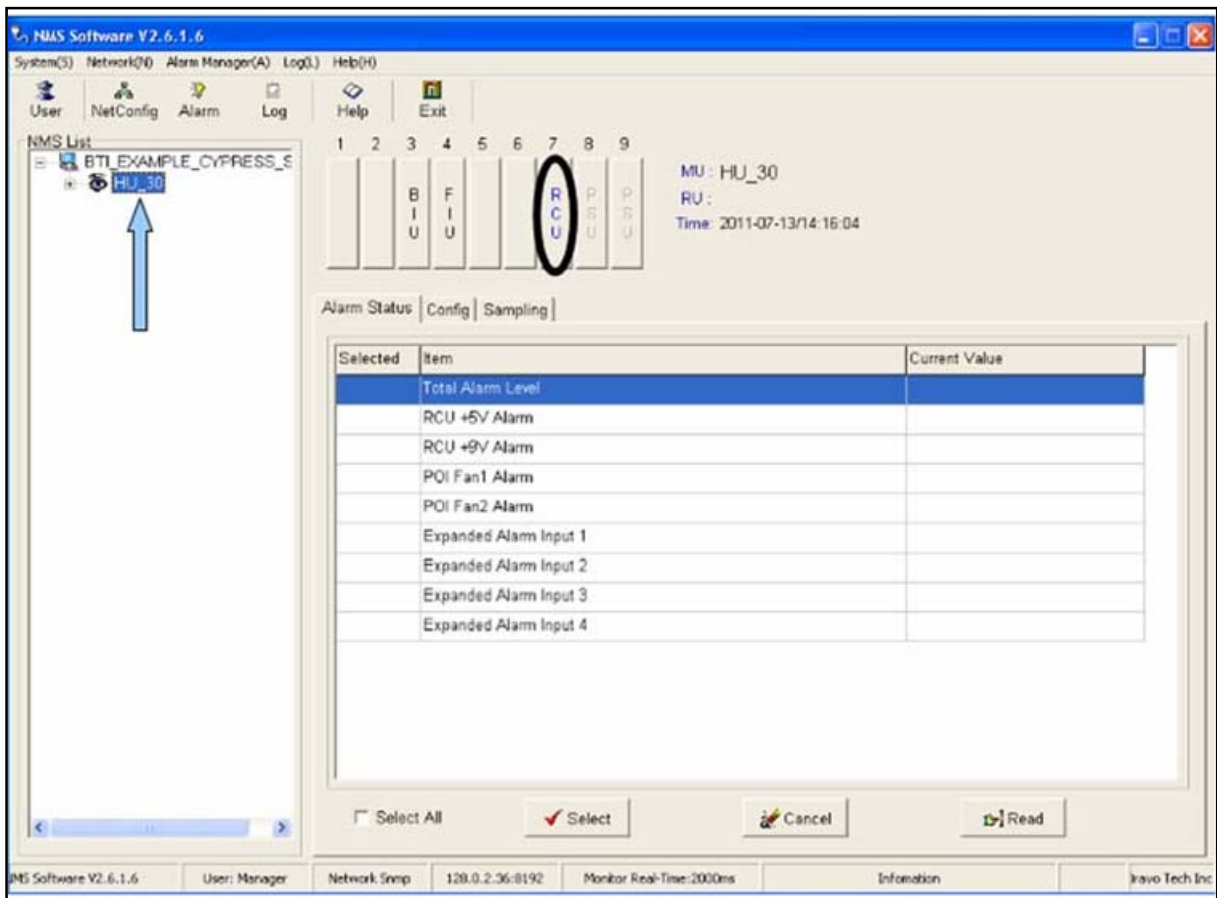

Figure 5-11. Select the HU

4. Click on *Parameter List*. Then click *Select All*.
5. Click on *Read*, **Figure 5-12**.

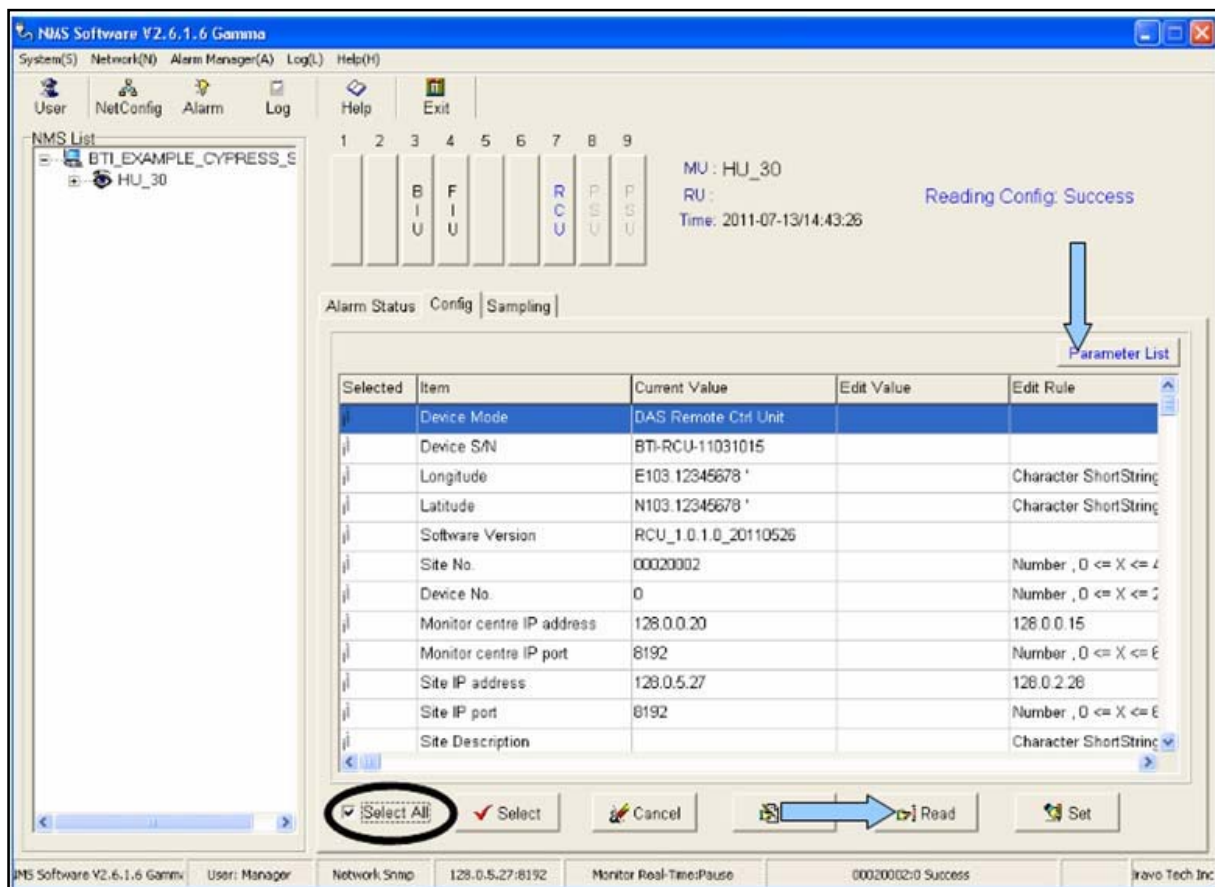

Figure 5-12. View the Current Values

6. Confirm *Select All* is unchecked. Click on Site IP Address in the Parameter List.
7. Click *Edit*.
8. Enter the new IP Address in the Edit Value Column, **Figure 5-13**.
9. Click *Set*, **Figure 5-14**.

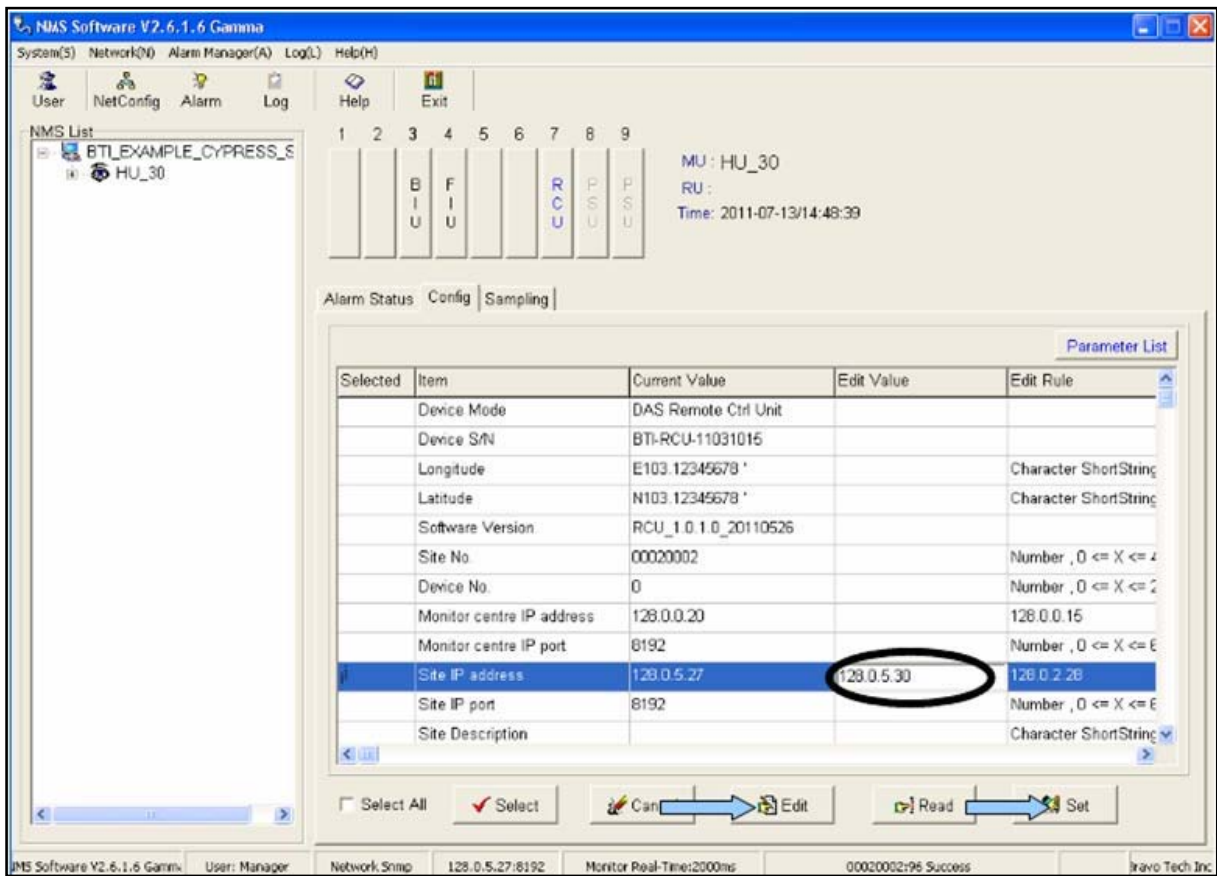

Figure 5-13. Enter the New IP Address

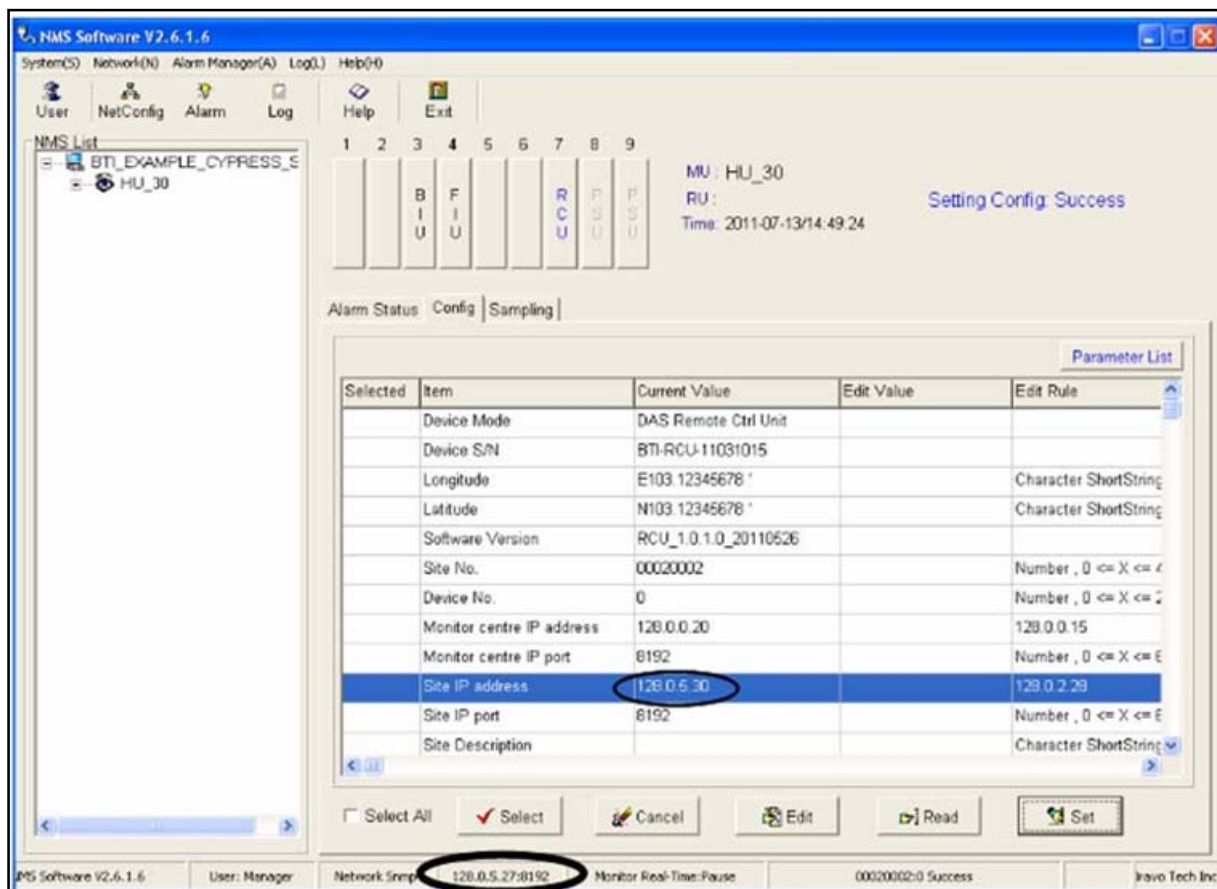
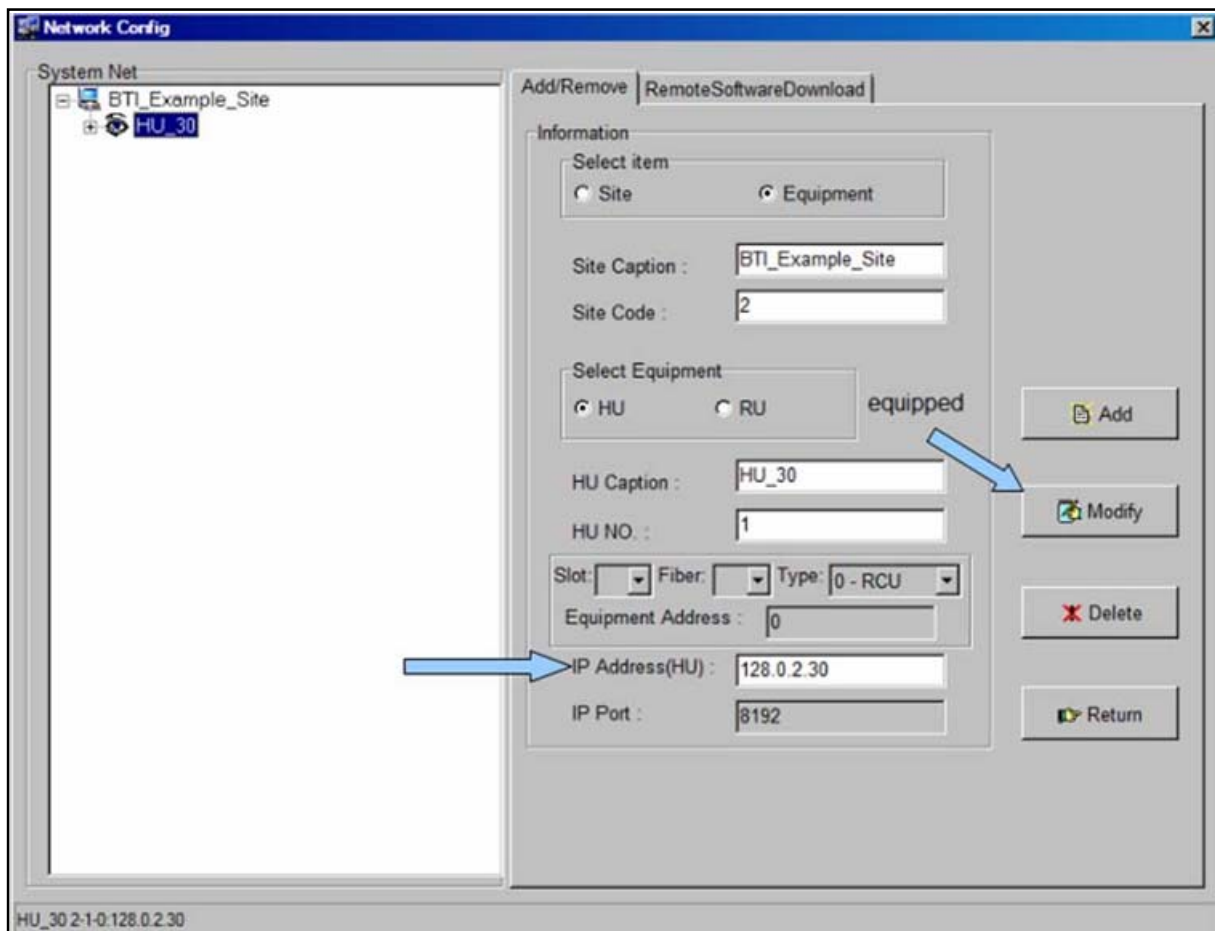

Figure 5-14. IP Address Update Setting

## 5.2.4 Map the IP Address to the NMS Software

1. Click the Netconfig button.
2. Select the Host Unit. **Figure 5-15.**
3. Change the *IP Address(HU)* from the default value to the designated network IP address. This will map the IP Address in the NMS System to the HU hardware card.
4. Then Click *Modify*. Click Return
5. Restart NMS to set the new parameters.





**Figure 5-15. Modify IP Address(HU)**

From the Main Command Screen:

1. Select the updated Host Unit.
2. Click on *Parameter List*. Then click *Select All*.
3. Click on *Read*, **Figure 5-16**.
4. Confirm that the HU Hardware Card IP Address matches.

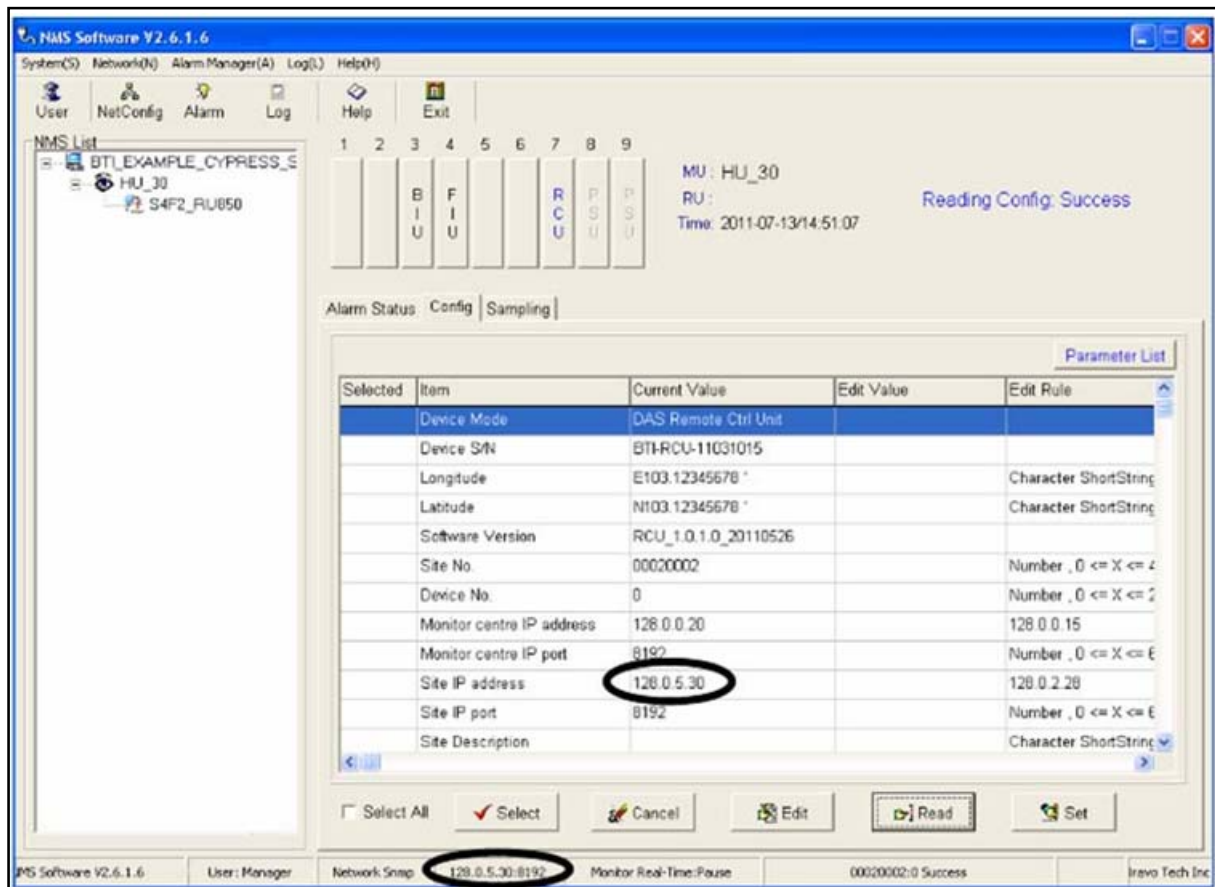

Figure 5-16. Confirm IP Address Update Accepted.

## 5.2.5 Add a Master Remote

Once the Site Caption, Site Code, and Host Unit have been configured, the Master Remote Unit should be added to the system. The alpha-numeric text fields accept any user-defined descriptive *RU Caption* (20 alpha-numeric character limit) and *RU No.* (1 through 9999 numeric limit). The following steps provide the Remote Unit configuration:

1. Click on the new HU in the *System Net* section.
2. Click on *Equipment* to bring up the new information section for the DAS System equipment.
3. Click on *RU* in the *Select Equipment* section.
4. Select the *Slot No.* for the Master Remote Unit. (This is generally Slot 2).
5. Select the *Fiber* value.
6. Select the *Type* of Remote Unit.
7. NMS creates a default name based on the chosen slot, fiber and type values selected as shown in **Figure 5-17**. Modify the Remote Unit Caption with a customer designated name, if desired.
8. Verify that the Site Caption, Site Code and HU No. are correct for the Remote Unit being added
9. Click *Add*.

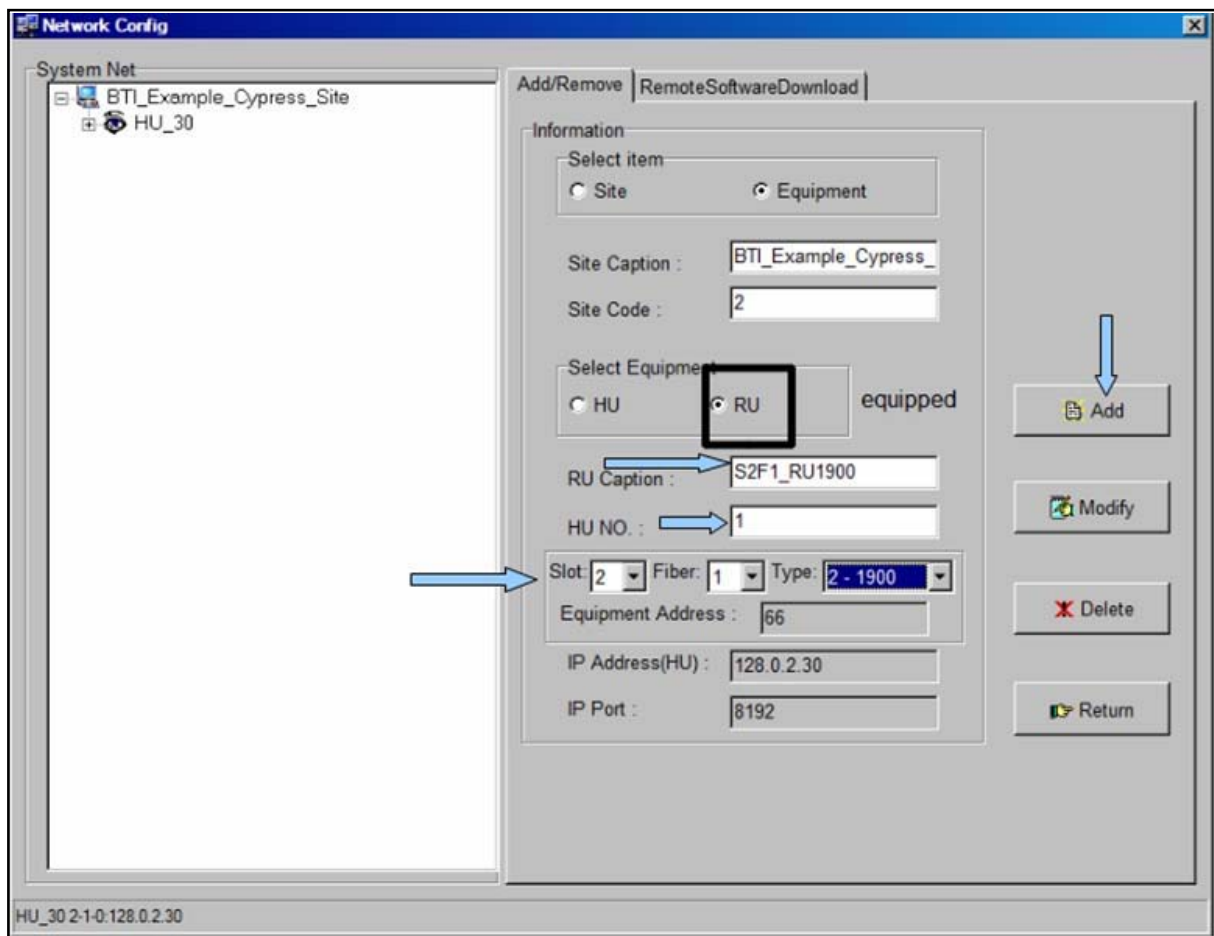

Figure 5-17 Adding Master Remote Unit

## 5.2.6 Add a Slave Remote

To complete the system activation, Slave Remote Units should be added to the system. The alphanumeric text fields accept any user-defined descriptive *RU Caption* (20 alpha-numeric character limit) and *RU No.* (1 through 9999 numeric limit). The following steps provide the Remote Unit configuration:

7. Click on the new HU in the *System Net* section.
8. Click on *Equipment* to bring up the new information section for the DAS System equipment.
9. Click on *RU* in the *Select Equipment* section.
10. Select the *Slot No.* for the Slave Remote Unit. (This should match the Master RU configuration).
11. Select the *Fiber* value.
12. Select the *Type* of Remote Unit.
13. NMS creates a default name based on the chosen slot, fiber and type values selected as shown in **Figure 5-18**. Modify the Remote Unit Caption with a customer designated name, if desired.
14. Verify that the Site Caption, Site Code and HU No. are correct for the Remote Unit being added.
15. Click *Add*.

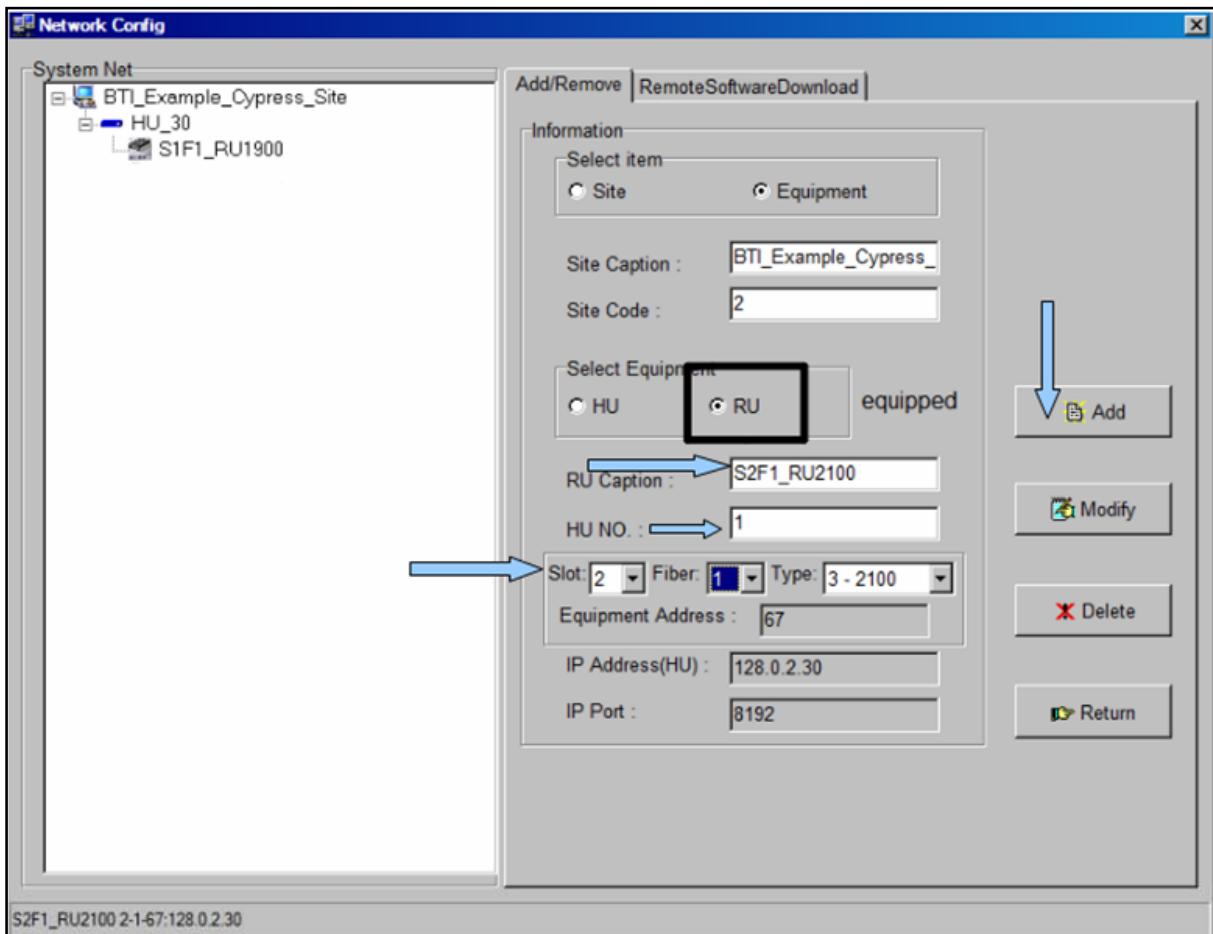

Figure 5-18. Adding a Slave Remote Unit

Table 5-2. Slots, Fiber and Type Values

Name	Configuration Value
Slot	Represents the slots on the HU from Left to Right that can be assigned to various equipment. Slots 1-6 are reserved for the FIU and BIU. Designating a slot number maps the RU to an FIU.
Fiber	Maps the RU to the Fiber connection on the Host Unit to the associated FIU.
Type	Defines the frequency used and must match the RU type installed. There are currently four different types of Remote Units. 700 MHz, 850 MHz, 1900 MHz, and 2100 MHz.

## 5.2.7 Connect Host Unit to Server

With the IP address updated, the Host Unit must be connected the server, **Figure 5-19**, for communication information to function. The Host Unit is connected from the Network port on the back interface through the hub to the server as shown in **Figure 5-20** or may be directly connected from the back interface port to the server. The Host Unit may also be connected to the server from the RCU network port on the front interface, either directly or through the hub to the server. Only one network port connection may be used at a time.

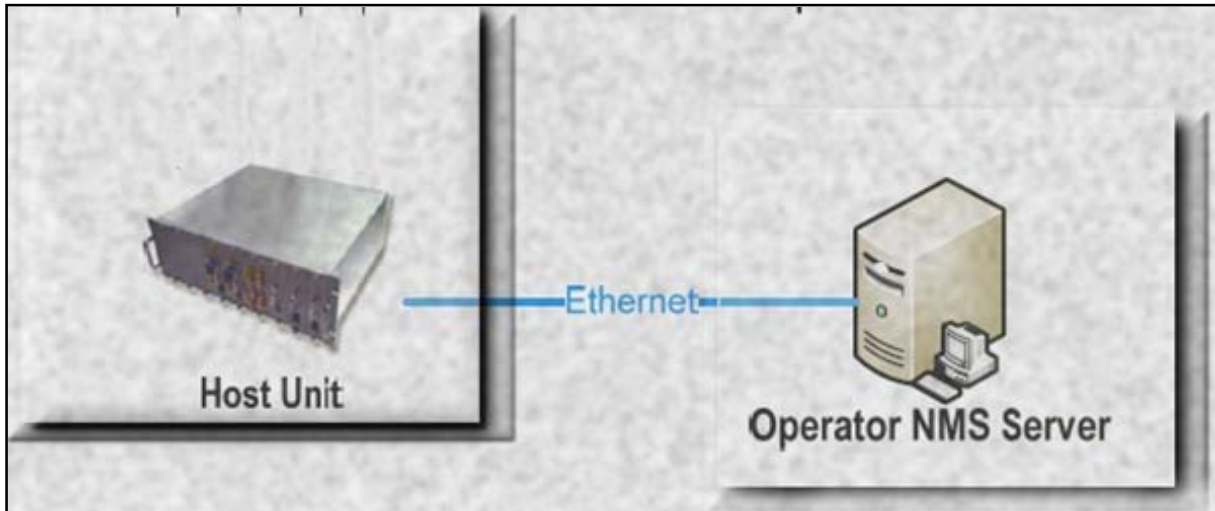

Figure 19. Connect Host Unit to Server



Only one port may be connected to the server at a time, as both front interface and back interface network ports are the same port.



Figure 5-20. HU Back Interface Network Connection

## 5.3 MANAGING AND MONITORING ALARMS

### 5.3.1 Alarm Manager

The NMS is also the means for managing and monitoring the DAS systems through the *Alarm Manager(A)* menu or the Alarm Icon on the Menu bar. The managing and monitoring of the DAS system is more completely detailed in the BTI NMS User Manual.

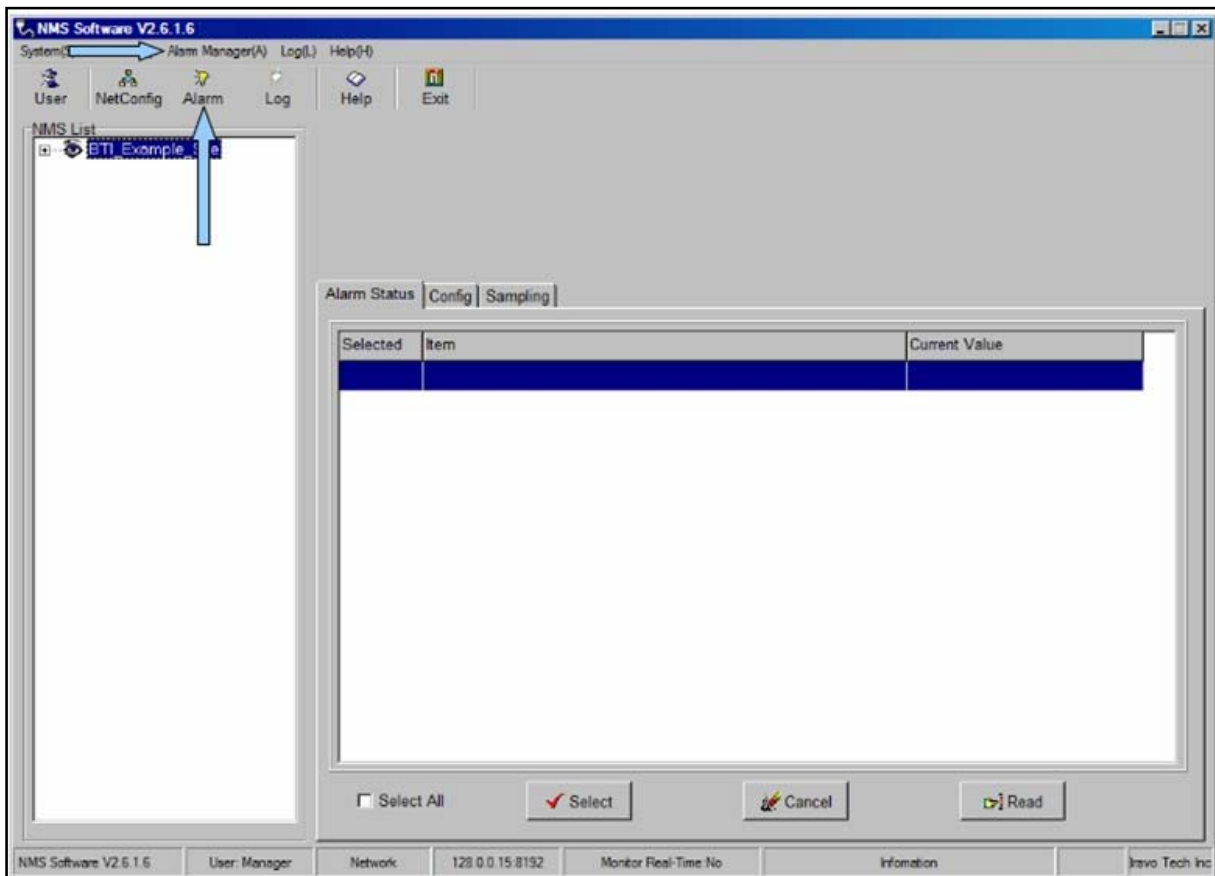

Figure 5-21. Alarm Manager

### 5.3.2 Configuring Standard Alarm Defaults

Configuring NMS is easily accomplished through the Custom Alarm tab, **Figure 5-21**. Select the alarm type and click the *Select* button for the appropriate category. **Table 5-3** provides a recommended list of alarms by category that may be selected to create a custom alarm configuration.

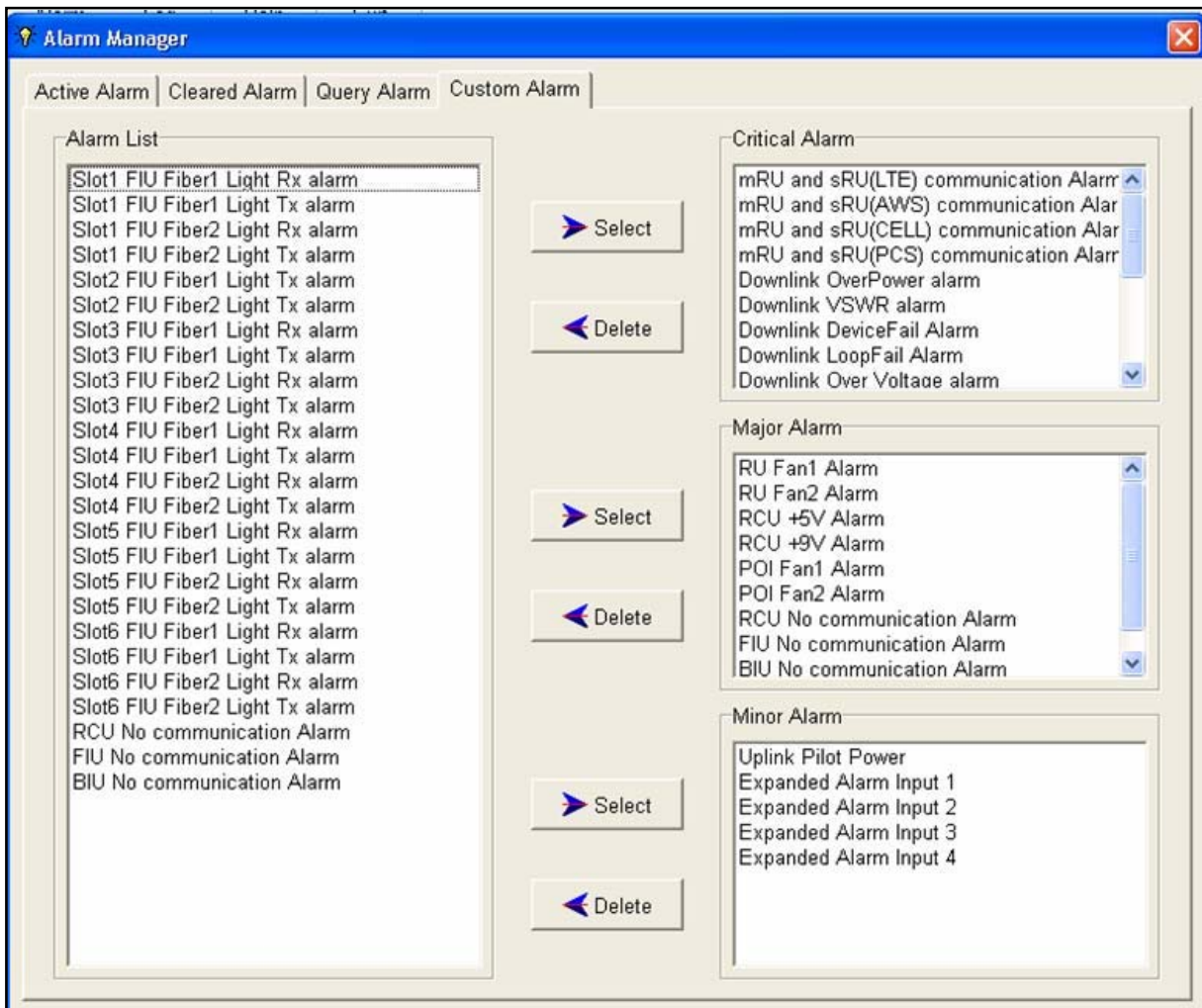

Figure 5-22. Configuring Custom Alarm Levels

Figure 5-23 shows an active alarm.

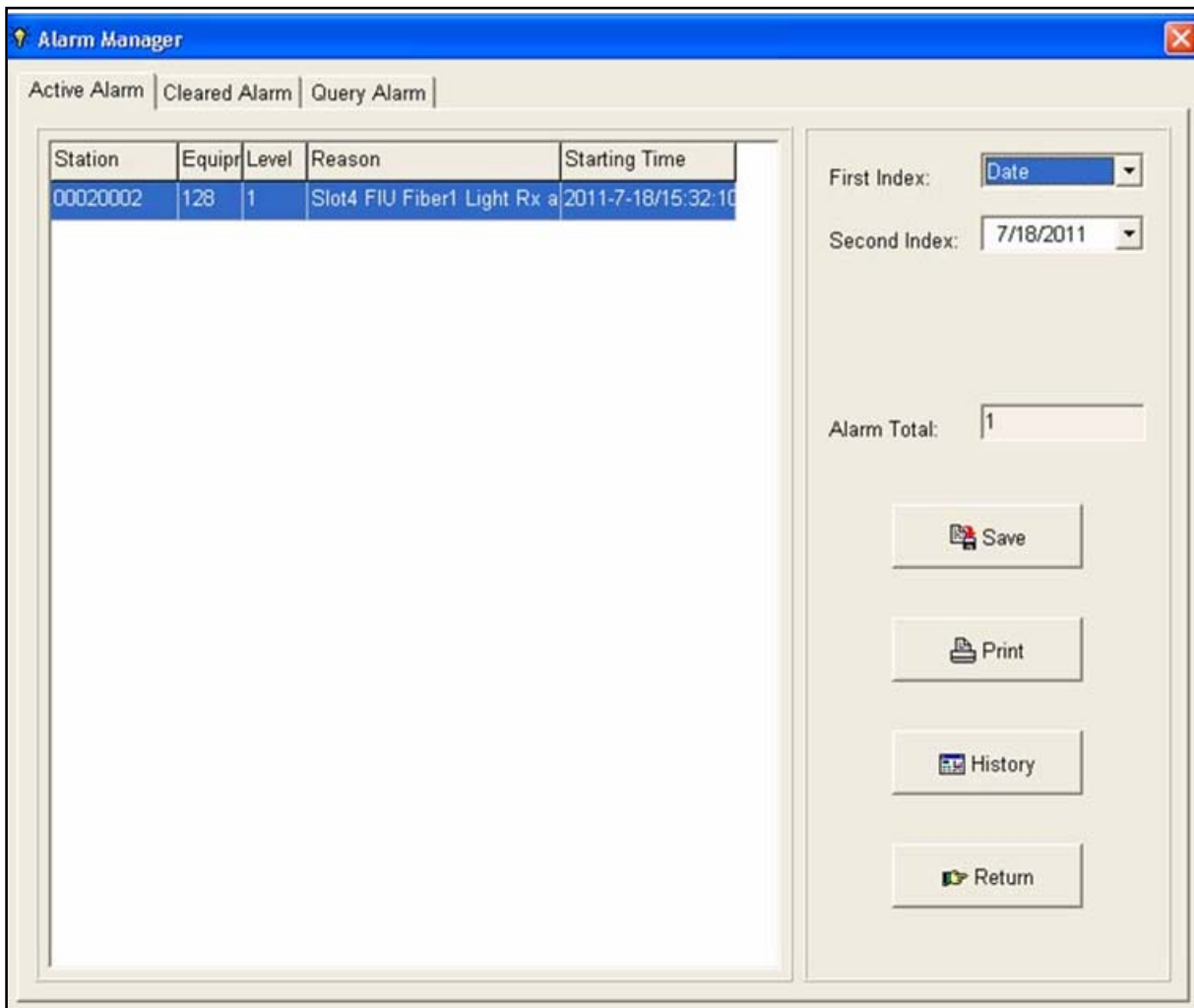

Figure 5-23. Active Alarm Screen

The **Table5-3** provides alarm indicator descriptions for the mBSC DAS system. Alarm types for the Host Unit and Remote Unit monitored by the NMS are included as well as optional components such as the POI. The recommended category for the alarm indicator is included in column 3 of the table along with the affected component. Critical alarms indicate system failures that disable the uplink or downlink operation. Other categories, such as Major, may indicate impaired performance, but not the catastrophic system failure or a specific RU node failure.

Table 5-3. Host Unit Alarm Indicators

Alarm Indicator	Description	Category	Component
Downlink OverPower	Transmit Power exceeds rated output	Critical	PA
Downlink VSWR	Antenna system VSWR exceeds preset level	Critical	PA
Downlink OverVoltage	PA Power supply over voltage	Critical	PA
Downlink DeviceFail	Downlink system critical failure	Critical	PA
Downlink LoopFail	Downlink MCPA IM cancellation not functioning	Critical	Fiber Module PA
Downlink	MCPA is operating at an unsafe	Critical	Fiber Module PA



Alarm Indicator	Description	Category	Component
OverTemperature	temperature		
Fiber Light Rx	RU fiber RX failure	Critical	Remote Unit
Fiber Light Tx	RU fiber TX failure	Critical	Remote Unit
mRU and sRU1(LTE) comm	Master to Slave communications failed	Critical	Remote Unit
mRU and sRU2(AWS) comm	Master to Slave communications failed	Critical	Remote Unit
mRU and sRU2(Cell) comm	Master to Slave communications failed	Critical	Remote Unit
mRU and sRU2(PCS) comm	Master to Slave communications failed	Critical	Remote Unit
RU Fan1	RU Fan failure	Major	Remote Unit
RU Fan2	RU Fan failure	Major	Remote Unit
LNA	RU Receive LNA failure	Critical	Remote Unit
RU/PA communication	RU Internal PA to CPU comm failure	Major	Remote Unit
Uplink Pilot Power	Uplink Pilot Power Failure	Minor	Remote Unit
RCU No Communication	NMS to RCU comm failure	Major	Host Unit
FIU No Communication	FIU to RCU comm failure	Major	Host Unit
BIU No Communication	BIU to RCU comm failure	Major	Host Unit
Fiber1 Light RX	FIU Fiber1 port RX light fail	Critical	Host Unit FIU
Fiber1 Light TX	FIU Fiber1 port TX light fail	Critical	Host Unit FIU
Fiber2 Light RX	FIU Fiber2 port RX light fail	Critical	Host Unit FIU
Fiber2 Light TX	FIU Fiber2 port TX light fail	Critical	Host Unit FIU
RCU +5V	Host Unit RCU power supply alarm	Major	Host Unit RCU
RCU +9V	Host Unit RCU power supply alarm	Major	Host Unit RCU
POI Fan1	POI Fan1 failure	Major	Host Unit POI
POI Fan2	POI Fan2 failure	Major	Host Unit POI
Expanded Alarm Input 1	Expansion	User Defined	Third Party Component
Expanded Alarm Input 2	Expansion	User Defined	Third Party Component
Expanded Alarm Input 3	Expansion	User Defined	Third Party Component

Alarm Indicator	Description	Category	Component
Expanded Alarm Input 4	Expansion	User Defined	Third Party Component

### 5.3.3 System Activation Review

Table 5-4. System Start-up Review

Items	Description
1	Verify that the Host Unit communication was established.
2	Confirm that at least one Site has been added.
3	Verify that the Host Unit Hardware card IP address has been configured.
4	Check that the Remote Unit is communicating with the Host Unit
5	Confirm that the Host Unit is connected to the Server.

### 5.3.4 Troubleshooting

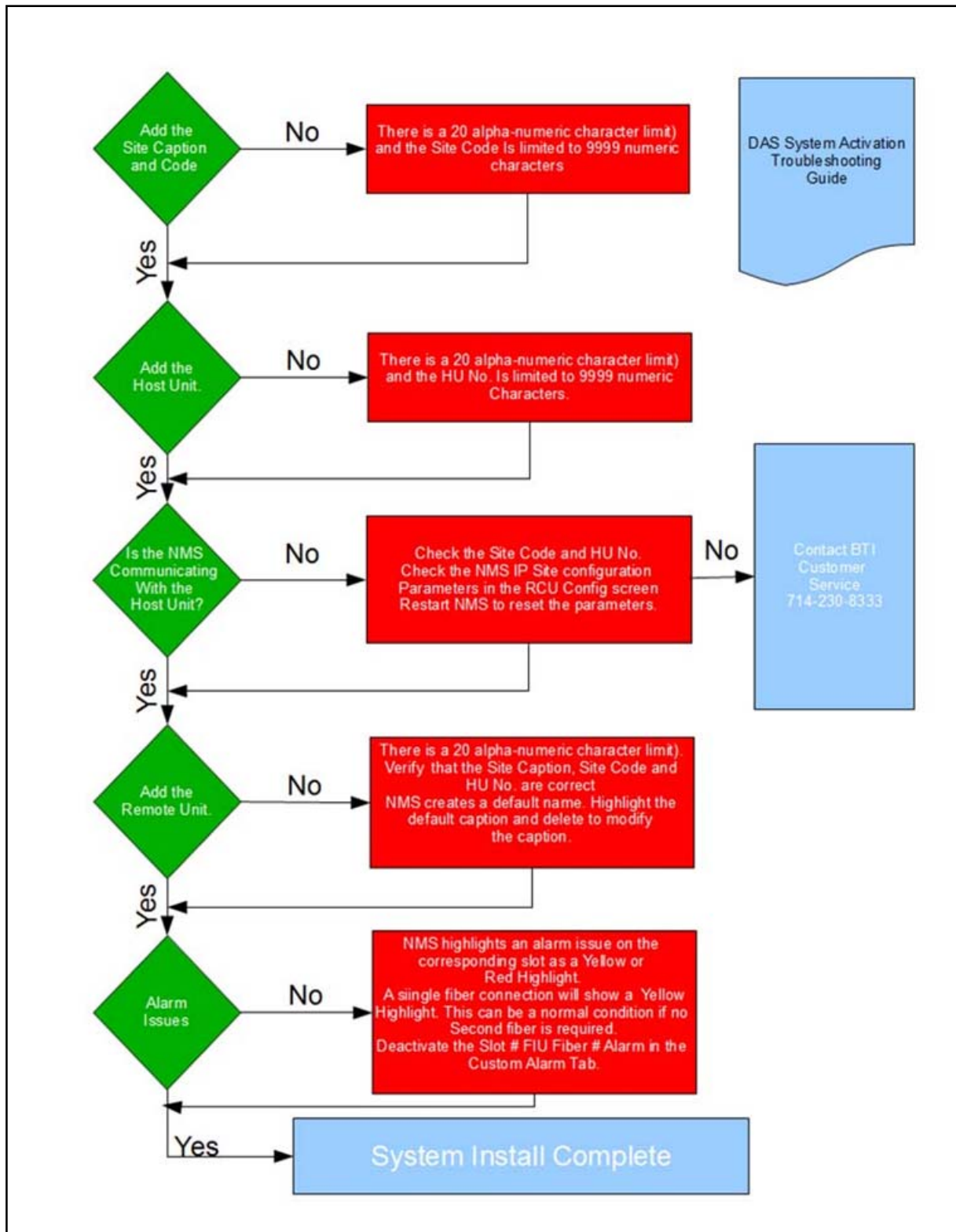

## 6 CUSTOMER SERVICE CONTACT INFORMATION

### USA



#### BTI

6185 Phyllis Dr. Unit D. Cypress, CA 90630, USA

Tel: +1 714-230-8333

Fax: +1 714-230-8341

E-mail:

Customer Service: [CustomerService@bravotechinc.com](mailto:CustomerService@bravotechinc.com)

Sales: [sales@bravotechinc.com](mailto:sales@bravotechinc.com)

### China



#### BTI (Shenzhen) Co., Ltd.

No.8 Building, Zone #3, Tangtou Industrial Park,  
Shiyan, Baoan District, Shenzhen, Guangdong  
P.R.China 518102

Tel: +86 755-2951-2233

Fax: +86 755-2951-2299

E-mail: [chinasales@bravotechinc.com](mailto:chinasales@bravotechinc.com)

This device complies with part 15 of the FCC Rules. Operation is subject to the following two conditions:

- (1) This device may not cause harmful interference, and
- (2) this device must accept any interference received, including interference that may cause undesired operation

Changes or modifications not expressly approved by the party responsible for compliance could void the user's authority to operate the equipment.

NOTE: This equipment has been tested and found to comply with the limits for a Class A digital device, pursuant to Part 15 of the FCC Rules. These limits are designed to provide reasonable protection against harmful interference in a residential installation. This equipment generates, uses and can radiate radio frequency energy and, if not installed and used in accordance with the instructions, may cause harmful interference to radio communications. However, there is no guarantee that interference will not occur in a particular installation. If this equipment does cause harmful interference to radio or television reception, which can be determined by turning the equipment off and on, the user is encouraged to try to correct the interference by one or more of the following measures:

- Reorient or relocate the receiving antenna.
- Increase the separation between the equipment and receiver.
- Connect the equipment into an outlet on a circuit different from that to which the receiver is connected.
- Consult the dealer or an experienced radio/TV technician for help.

#### **FCC Radiation Exposure Statement**

This equipment complies with FCC radiation exposure limits set forth for an uncontrolled environment. This equipment should be installed and operated with minimum distance 400cm between the radiator & your body.