

Document Name:

mBSC2500L-005-RUCM11

Revision:

001.01A

Effective Date:

4/15/2013



USER MANUAL

mBSC2500L-005-RUCM11

**Medium-Power
Coverage Solution**



6185 Phyllis Drive
Cypress, CA 90630
USA
PH: 714.230.8333

Visit our Website at www.BTIwireless.com



Copyright © 2015 BTI Wireless All rights reserved.

No part of this publication may be reproduced, transmitted, transcribed, stored in a retrieval system, or translated into any language, in any form or by any means, electronic, mechanical, photocopying, recording, or otherwise, without prior written permission from BTI Wireless.

All copyright, confidential information, patents, design rights and all other intellectual property rights of whatsoever nature contained herein are and shall remain the sole and exclusive property of BTI Wireless. The information furnished herein is believed to be accurate and reliable.

However, no responsibility is assumed by BTI Wireless for its use, or for any infringements of patents or other rights of third parties resulting from its use.

The BTI Wireless name and BTI Wireless logo are trademarks or registered trademarks of BTI Wireless

All other trademarks are the property of their respective owners

Document History

Paper copies are valid only on the day they are printed. Contact the author if you are in any doubt about the accuracy of this document.

Revision History

Revision Number	Revision Date	Summary of Changes
001.00A	5/28/2013	Initial Release for NA

GENERAL SAFETY PRECAUTIONS

Warning: Wet conditions increase the potential for receiving an electrical shock when installing or using electrically-powered equipment. To prevent electrical shock, never install or use electrical equipment in a wet location or during a lightning storm.

Warning: This is NOT a CONSUMER device. It is designed for installation by FCC LICENSEES and QUALIFIED INSTALLERS. You MUST have an FCC LICENSE or express consent of an FCC License to operate this device. Unauthorized use may result in significant forfeiture penalties, including penalties in excess of \$100,000 for each continuing violation.

Improper installation and operation of this equipment outside of the recommended installation procedures, and operation beyond the designed operating specifications, and/or not in compliance with regulatory requirements, will revoke any warranty and may:

- Prevent the equipment from performing properly
- Violate regulatory RF emissions requirements
- Require removal of the equipment from service.

TABLE OF CONTENTS

1	INTRODUCTION	1
1.1	SYSTEM SOLUTION BLOCK DIAGRAM	1
1.1.1	<i>Host Unit</i>	1
1.1.2	<i>Remote Node</i>	2
2	SAFETY	3
3	SYSTEM OVERVIEW AND UNIT DESCRIPTION	4
3.1	SYSTEM OVERVIEW	4
3.1.1	<i>Interface with BTS</i>	5
3.1.2	<i>Interface with Cellular Phones</i>	5
3.1.3	<i>Fiber Optic Transport</i>	5
3.1.4	<i>Powering</i>	5
3.1.5	<i>Cooling</i>	5
3.1.6	<i>Fault Detection and Alarm Reporting</i>	5
3.2	HOST UNIT DESCRIPTION	6
3.2.1	<i>Host Unit Components</i>	6
3.2.2	<i>Mounting</i>	9
3.2.3	<i>Fault Detection and Alarm Reporting</i>	9
3.2.4	<i>RF Signal Connections</i>	9
3.2.5	<i>Optical Connections</i>	9
3.2.6	<i>Powering</i>	10
3.2.7	<i>Host Unit Interface</i>	10
3.3	REMOTE NODE DESCRIPTION	12
3.3.1	<i>BCM Enclosure</i>	12
3.3.2	<i>Single-band RUM Enclosure</i>	14
3.3.3	<i>RTM</i>	18
3.3.4	<i>RPM</i>	22
4	SYSTEM INSTALLATION	25
4.1	UNPACKING AND INSPECTION	25
4.2	INSTALLATION PREPARATION	25
4.2.1	<i>Required Tools</i>	25
4.2.2	<i>Installation Location</i>	25
4.2.3	<i>Anti-corrosion and Shock-protection</i>	26
4.2.4	<i>Lighting, Ventilation and Fire Protection</i>	26
4.2.5	<i>Power Requirements</i>	26

4.2.6	<i>Lightning Protecting and Grounding</i>	26
4.3	HOST UNIT INSTALLATION	27
4.3.1	<i>Rack Mounting</i>	27
4.3.2	<i>Cable Connections</i>	28
4.4	REMOTE NODE INSTALLATION	33
4.4.1	<i>Cable Connections</i>	33
4.5	INSTALLATION FINAL INSPECTION	37
4.5.1	<i>Host Unit Connection Overview</i>	38
4.5.2	<i>Remote Node Connection Overview</i>	39
4.5.3	<i>mBSC-C Inspection Checklist</i>	40
4.5.4	<i>Cabling Inspection</i>	40
4.6	SYSTEM TEST	40
5	SYSTEM MONITORING & CONFIGURATION	42
5.1	ACCESSING EMS LOCAL GUI	42
5.1.1	<i>Using Ethernet Port</i>	42
5.1.2	<i>Using USB Port</i>	43
5.1.3	<i>Login to EMS Local GUI</i>	44
5.2	NAVIGATING THE EMS LOCAL GUI	46
5.2.1	<i>Topology Tool Bar</i>	47
5.2.2	<i>Upgrade/Password Functions</i>	48
5.3	INSTALLATION & CONFIGURATION	48
5.3.1	<i>Network & Communications</i>	48
5.3.2	<i>System Installation</i>	50
5.3.3	<i>Alarms</i>	55
5.4	SYSTEM TUNING	57
5.4.1	<i>BTS Signal Conditioning</i>	57
5.4.2	<i>Set Downlink Gain</i>	57
5.4.3	<i>Set Uplink Gain</i>	60
5.4.4	<i>Link Verification</i>	62
5.5	MONITORING AND ALARMS	64
5.5.1	<i>Operational Status</i>	64
5.5.2	<i>System Alarms</i>	66
5.6	SYSTEM UPGRADE	67
5.6.1	<i>Verify Software Versions</i>	67
5.6.2	<i>Upgrade component software</i>	67
6	MAINTENANCE	68

6.1	ELECTROSTATIC DISCHARGE PRECAUTIONS	68
6.2	PREVENTATIVE MAINTENANCE	68
6.3	FAULT DETECTION AND ALARM REPORTING	68
6.4	TROUBLESHOOTING QUICK GUIDE	69
6.4.1	<i>Host Unit Trouble Shooting</i>	70
6.4.2	<i>Remote Unit Trouble Shooting</i>	71
7	TERMS, ACRONYMS & ABBREVIATIONS	72
8	PACKING LIST	73

LIST OF FIGURES

FIGURE 1 BLOCK DIAGRAM OF HOST UNIT 1

FIGURE 2 BLOCK DIAGRAM OF REMOTE NODE 2

FIGURE 3 MBSB SYSTEM FUNCTIONAL OVERVIEW 4

FIGURE 4 HOST UNIT 6

FIGURE 5 BIU 7

FIGURE 6 FIU 7

FIGURE 7 PSU 8

FIGURE 8 RCU 9

FIGURE 9 HOST UNIT USER INTERFACE 11

FIGURE 10 FIBER BCM ENCLOSURE OUTLINE 13

FIGURE 11 FIBER BCM INTERIOR LAYOUT 13

FIGURE 12 BCM ENCLOSURE USER INTERFACE 14

FIGURE 13 SINGLE-BAND RU ENCLOSURE 15

FIGURE 14 SINGLE-BAND RU ENCLOSURE USER INTERFACE 17

FIGURE 15 RTM ENCLOSURE 19

FIGURE 16 RTM INTERIOR LAYOUT 20

FIGURE 17 RTM INTERFACE 22

FIGURE 18 RPM OUTLINE 23

FIGURE 19 RPM INTERIOR LAYOUT 24

FIGURE 20 MOUNTING BRACKETS FOR 19" RACK INSTALLATION 27

FIGURE 21 HOST UNIT-19" RACK MOUNTING VIEW 28

FIGURE 22 HOST UNIT GROUNDING STUD 29

FIGURE 23 GROUNDED HOST UNIT 29

FIGURE 24 BTS QMA COAXIAL CABLE CONNECTION 30

FIGURE 25 SINGLE MODE PATCH CORD(E2000/APC) 31

FIGURE 26 E2000 FIBER OPTIC PORT ON HOST UNIT FIU 31

FIGURE 27 48VDC HOST POWER CONNECTION 31

FIGURE 28 IP CONNECTION FOR LOCAL GUI CONTROL 32

FIGURE 29 MODEM PORT ON RCU (DB9 MALE) 32

FIGURE 35 RF INTER-CONNECT BETWEEN BCM AND SINGLE-BAND RU 34

FIGURE 36 RF INTER-CONNECT BETWEEN RTM AND SINGLE-BAND RU 35

FIGURE 37 FIBER OPTIC CABLE CONNECTION TO RTM ENCLOSURE 36

FIGURE 38 RPM 37

FIGURE 40 HOST UNIT CONNECTION OVERVIEW 38

FIGURE 41 REMOTE NODE INTER-CONNECTION DIAGRAM39

FIGURE 42 FLOW CHART OF SYSTEM DEBUGGING41

FIGURE 43- EMS LOCAL GUI LOGIN.....44

FIGURE 44- MAIN PAGE EXPANDED TOPOLOGY46

FIGURE 45- MAIN PAGE SUMMARY VIEW47

FIGURE 46- RCU COMPONENT VIEW49

FIGURE 47- MAIN PAGE EQUIPMENT STATUS.....51

FIGURE 48- FIU OPTICAL POWER LEVELS53

FIGURE 49- RTM OPTICAL POWER LEVELS.....53

FIGURE 50 - EMS LOCAL GUI SOFTWARE VERSION.....54

FIGURE 51 - COMPONENT SOFTWARE VERSIONS54

FIGURE 52 – OPTICAL LINK ALARMS.....56

FIGURE 53 - BIU ATTENUATOR58

FIGURE 54 - RU ATTENUATOR60

FIGURE 55 – Up/DOWN LINK VERIFICATION63

FIGURE 56 - HOST UNIT ALARM STATUS64

FIGURE 57 - REMOTE NODE ALARM STATUS65

FIGURE 58 - COMPONENT UPGRADE.....67

FIGURE 59HOST UNIT TROUBLE SHOOTING70

FIGURE 60REMOTE UNIT TROUBLE SHOOTING71

LIST OF TABLES

TABLE 1 HOST UNIT USER INTERFACE..... 10

TABLE 2 HOST UNIT INDICATOR DESCRIPTION 12

TABLE 6 BCM ENCLOSURE USER INTERFACE 14

TABLE 7 SINGLE-BAND RUM ENCLOSURE USER INTERFACE 17

TABLE 8 INDICATOR DESCRIPTION..... 17

TABLE 3 RF-OPTIC TRANSCEIVER INTERFACE..... 20

TABLE 4 DB9 PINOUTS 20

TABLE 5 RF-OPTIC TRANSCEIVER INDICATORS 21

TABLE 6 FIBER RTM ENCLOSURE USER INTERFACE 21

TABLE 8 INDICATOR DESCRIPTION..... 22

TABLE 10 MBSU UNIT INSPECTION 40

TABLE 11 CABLE INSPECTION..... 40

TABLE 12 LOCAL GUI DEFAULT USER ACCOUNTS 44

TABLE 13 TOOL BAR FUNCTIONS 47

TABLE 14 GENERAL GUI TOOLS 48

TABLE 15 SYSTEM ALARMS 66

TABLE 16 TROUBLESHOOTING QUICK GUIDE 69

TABLE 17 TERMS, ACRONYMS AND ABBREVIATIONS 72

1 Introduction

The MBSC-C Fiber Optic Coverage System is used to extend wireless coverage to specific areas in building(s), or throughout a complex zone. The mBSC product family offers a flexible, scalable, modular platform to improve signal quality and enhance the services to meet the increasing demands.

The MBSC-C system components include a Host Unit (HU) and a Remote Node. Each Host Unit can feed up to eight multi-band Remote Nodes, each utilizing a single fiber. A Remote Node can accommodate between one and five single-band bi-directional amplifiers (Remote Units) – install only the bands required at the time of deployment. As requirements change, additional single-band units can be easily installed in the field. This modular architecture provides optimum implementation flexibility, reduces initial cost, and defers further investment until required.

1.1 System Solution Block Diagram

The MBSC-C platform allows flexible system deployment to support mixed mode 700~2700MHz services in SISO configurations.

1.1.1 Host Unit

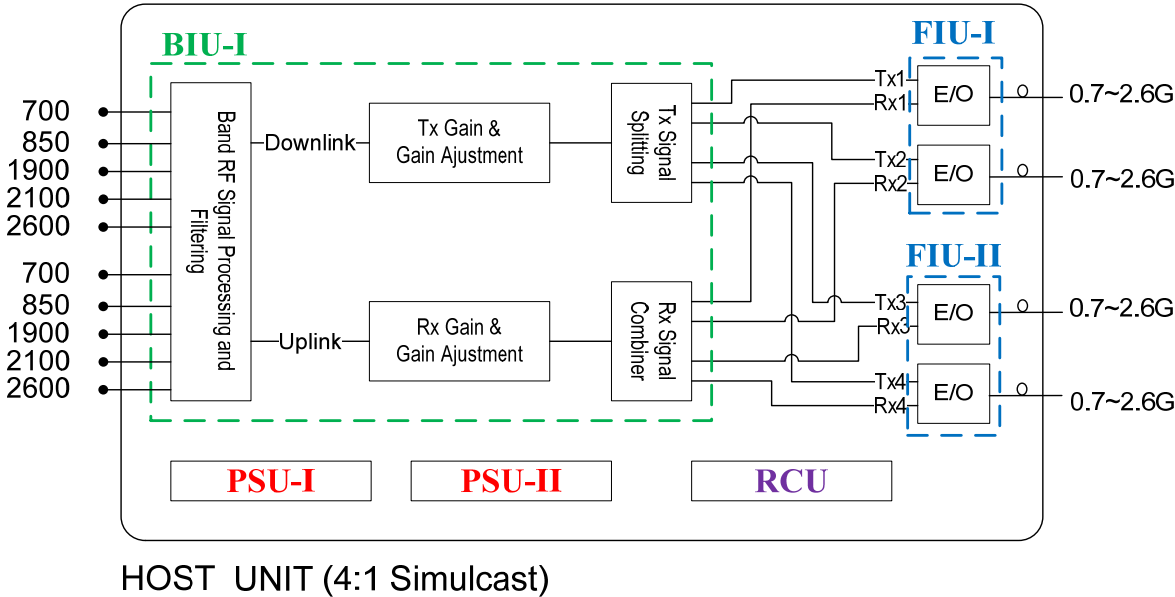

Figure 1Block Diagram of Host Unit

1.1.2 Remote Node

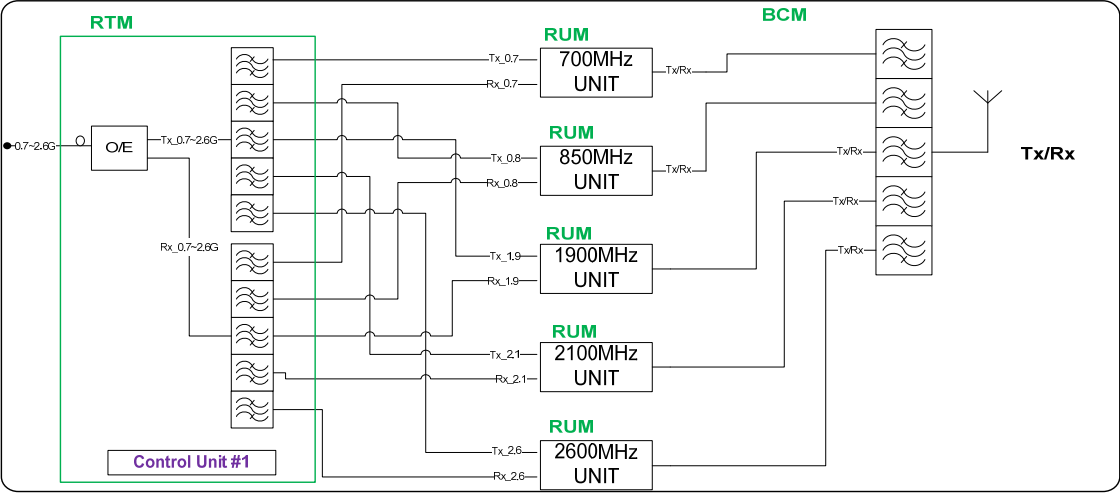

Figure 2 Block Diagram of Remote Node

2 Safety

Caution

All the following “Safety Precautions” must be observed during the entire installation and operation of the mBSC system.

1. The mBSC system is designed for maximum safety and reliability when installed, used, and maintained by trained and qualified technicians in accordance with the procedures and instructions contained in this manual. To assure the safe operation of your system, always follow the safety and operational recommendations in this manual.
2. Read and understand all instructions and warnings before handling the mBSC system.
3. **Warning:** Do not install or operate mBSC system in the presence of flammable gases or fumes.
4. **Warning:** mBSC system produces high level of RF radiation.
5. Do not operate exposed circuitry or radiating elements with personnel in close proximity to radiating source.
6. Persons with cardiac pacemakers should avoid exposure to RF radiating elements.
7. Exposing the human eye to high levels of radio-frequency radiation may result in the formation of cataracts.
8. **Warning:** We do not provide the antenna; the antenna and other cable set provide by customs. Please don't use unauthorized antennas, cables, and/or coupling devices.
9. **Warning:** To avoid injuries or damage, use care and obtain assistance before lifting the mBSC unit.
10. **Warning:** mBSC system should be installed only in restricted access areas (dedicated equipment room, equipment closet, or similarity designated areas) where access is controlled or where access can only be gained by service personnel with a key or tool. Access to this equipment is restricted to qualified service personnel only.



5. Warning: This is NOT a CONSUMER device. It is designed for installation by FCC LICENSEES and QUALIFIED INSTALLERS. You MUST have an FCC LICENSE or express consent of an FCC License to operate this device. Unauthorized use may result in significant forfeiture penalties, including penalties in excess of \$100,000 for each continuing violation. Warning label messages will be also shown in online and point-of-sale marketing materials and on outside packaging of device



6. For US and Canadian installations: FCC RF exposure compliance requires the following antenna installation and device operation configurations be satisfied: A separation distance of at least 6 meters must be maintained between the antenna of this device and all persons. RF exposure compliance may need to be addressed at the time of licensing, as required by the responsible FCC Bureau(s), including antenna co-location requirements of 1.1307(b)(3). Maximum permissible antenna gain is 17 dBi.

3 System Overview and Unit Description

3.1 System Overview

The MBSC-C system is a multi-operator, multi-band and multi-technology coverage system that provides in-building / venue coverage for up to five operating bands. Large buildings typically interfere with the transmission or reception of cellular phone system signals by imposing high attenuation losses on the RF signal. The mBSC system is designed to overcome these losses which otherwise make cellular communications within buildings or structures difficult or impossible. With the mBSC system, cellular phone RF signals can be distributed to the interior areas of any building or structure to eliminate dead spots and improve reception.

The MBSC-C coverage solution interconnects to, and extends, the wireless service provider base station equipment (BTS) and service antennas. A functional overview is illustrated below.

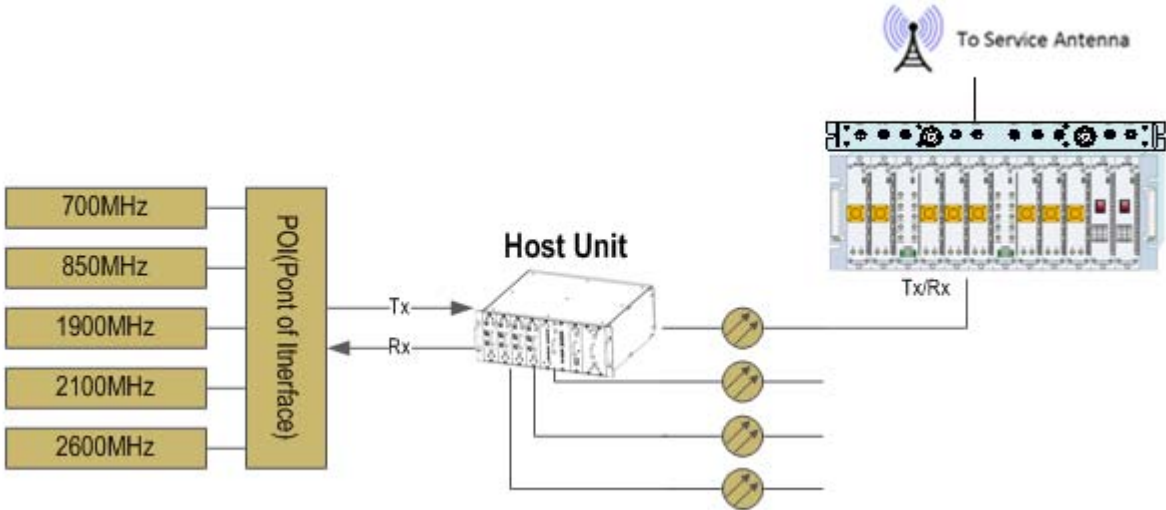

Figure 3mBSC System Functional Overview

The mBSC system provides downlink signal amplification and uplink sensitivity improvement for multi-band RF signals, which may be comprised of multiple carriers and multiple standards.

The Host Unit provides the input interface for RF signals from a base transceiver station (BTS). The Host Unit converts the RF signals into a digital format and distributes the digitized signal over fiber to multiple output ports. An optional Multi-operator Point-of-Interface (POI) combines multiband BTS inputs from several operators into a single TXin / RXout interface to the Host Unit. Refer to “SP-MBSC-C-POI” for additional details.

The Remote Node receives the optical signals from the Host Unit, converts the signals back into RF and interfaces with the service antennas to amplify the RF signals throughout the building. The Remote Node is typically wall-mounted within an equipment room.

3.1.1 Interface with BTS

The Host Unit is typically installed close to the wireless service provider BTS equipment. In the downlink path the Host Unit combines RF signals from up to 5bands and feeds the combined signal to a fiber-optic transceiver for transmission to the interconnected Remote Node(s). In the uplink path the Host Unit converts a composite multi-band optical signal into independent RF signals for interconnection with the BTS receive elements.

3.1.2 Interface with Cellular Phones

The mBSC Remote Node interfaces with the cellular phones through the service antennas. In the reverse path, the Remote Node receives RF signals from cellular phones. In the forward path, the Remote Unit transmits the RF signals to the cellular phones. A bi-directional antenna is connected to the mBSC Remote Node to transmit and receive RF signals from the cellular phones.

3.1.3 Fiber Optic Transport

The Host Unit is connected to each Remote Node over a single optical fiber. The optical fibers must be terminated with E2000/APC connectors for connection with the Host Unit and the Remote Node. For fiber transmission, and remote node equipment is required, along with an additional optical fiber.

3.1.4 Powering

The Host Unit is powered by -48V DC which is supplied by either the equipment room power distribution cabinet or an AC/DC converter. The Remote Node is powered by 110/220VAC, 50/60Hz power which is supplied through a power supply distribution junction box.

3.1.5 Cooling

The Host Unit is cooled through cross-convection without fans.

The Remote Node contains multiple single-band Remote Units, which are cooled through continuous air flow fans mounted on the top of each single-band unit. A minimum of 200mm (7.87 inches) of clearance space must be provided on both the top and the bottom sides of the Remote Node for air flow.

An alarm is provided that indicates if a high temperature condition occurs.

3.1.6 Fault Detection and Alarm Reporting

LED indicators are provided on the front panel of the Host Unit to indicate if the mBSC system is operating as expected (normal) or if a fault is detected. In addition, normally open and closed alarm contacts (for both major and minor alarms) are provided at the Host Unit for connection to a customer provided external alarm system.

The mBSC system also includes a standalone (optional) Element Management System server, which interconnects with each Host Unit in a multi-system deployment, and is used for system configuration, status monitoring, and SNMP alarm reporting / management.

3.2 Host Unit Description

As shown in Figure 4, the Host Unit is a standard 19"4U rack-mounted shelf, which serves as the BTS servicing unit for the mBSC system. The Host Unit provides the following basic functions:

- RF interface with BTS (Simplex TXin, RXout)
- Optical interface to Remote Nodes
- Conversion of the forward path(downlink) RF signals into up to four simulcast optical signals
- Conversion of up to four reserve(uplink) optical signals to RF signals
- Manages and monitors the system alarms and configurations
- Provides alarm information to a local alarm or remote system

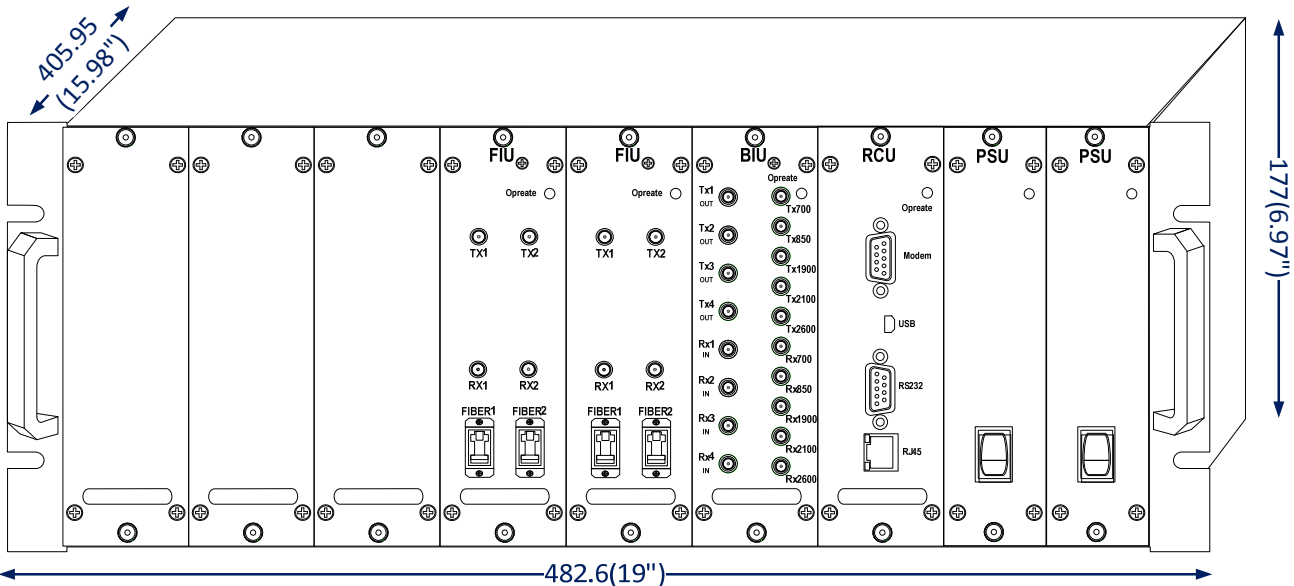

Figure 4 Host Unit

3.2.1 Host Unit Components

The Host Unit is a multi-slot chassis, consisting of 9 slots numbered from left to right: 1 through 9. Slots 7 through 9 are dedicated and specifically keyed for the Remote Control Unit (RCU) and two redundant Power Supply Units (PSUs). The Host Unit also houses the Base Station Interface Units (BIU) and Fiber Interface Units (FIU). The Host Unit allows any combination of BIU and FIU modules, up to six in total.

3.2.1.1 BIU (BTS Interface Unit)

The BIU is a frequency agnostic RF interface card that provides simplex TX input and RX output connections to the BTS equipment. The BIU combines up to 5 bands of RF downlink signal into a composite signal, which is then split across four TX out connectors for interconnection to up to four fiber modules (simulcast). In the uplink path the BIU combines up to four separate multi-band uplink signals for distribution

to the BTS receivers. Internal splitters, combiners, and software controlled attenuators enable customized designs to support various RF inputs scenarios.

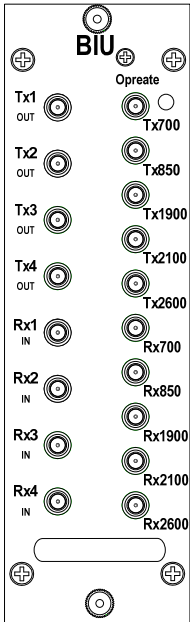

Figure 5BIU

3.2.1.2 FIU (Fiber Interface Unit)

The FIU provides the interface between the combined RF signals (BIU) and the optical fiber connections. Each FIU is equipped for 2 independent bi-directional fiber connections.

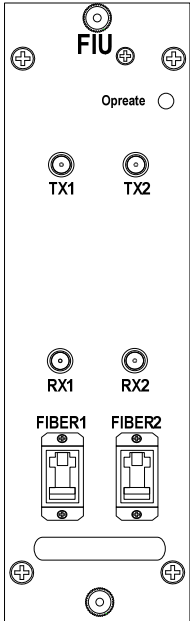

Figure 6FIU

3.2.1.3 PSU (Power Supply Unit)

The Host Unit is powered by -48V DC. The PSU takes the -48 VDC input source power and provides voltage conversion and distribution for the line cards installed within the host unit shelf. The host unit is equipped with 2 independent PSU's in parallel redundancy. Each PSU is hot swappable (one unit at a time only).

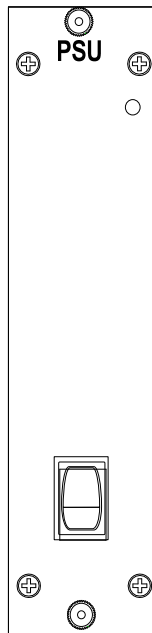

Figure 7 PSU

3.2.1.4 RCU (Remote Control Unit)

The RCU provides the control and interface for a local Operations and Maintenance Console (OMC) GUI, and a remote Element Management System (EMS) server through Ethernet or modem connection (optional).

The RCU is a hot swappable card and will not affect operation of the RF path if removed.

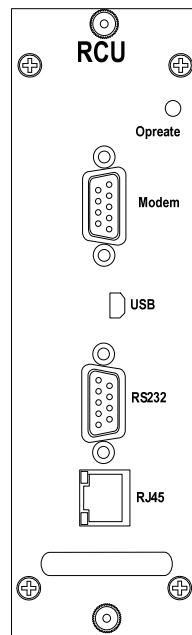

Figure 8RCU

3.2.2 Mounting

The Host Unit is intended for use in indoor, rack-mounted applications. For rack mounting, a pair of mounting brackets is provided that allows the Host Unit to be mounted in a 19" equipment rack. When rack-mounted, the front panel of the Host Unit is flush with the front of the rack.

3.2.3 Fault Detection and Alarm Reporting

The Host Unit detects internal circuitry faults and optical port faults. Various front panel LED indicators turn from green to red if a fault is detected or an optical input is lost. A set of dry-contact alarm points (normally open and normally closed) are also provided for interfacing with an external alarm system.

3.2.4 RF Signal Connections

RF signal connections with the BTS are supported through two QMA female connectors per RF Band (5 bands supported). One QMA connector per band is used for coaxial cable connection of the combined downlink path (TXin) RF signal. The other QMA connector is used for coaxial cable connection of the combined uplink path (RXout) RF signal.

Notes: The input RF signal level range to Host Unit is -10dBm - +10dBm, normally it is between -5~0dBm.

3.2.5 Optical Connections

The Host Unit optical connections to the Remote Unit are supported on the Fiber Interface Unit (FIU). Each FIU supports two independent optical paths, each consisting of a status LED, two QMA RF connectors, and an E2000/APC optical transceiver using single-mode fiber. Up to five bands of non-overlapping RF signal can be transported across a single fiber.

3.2.6 Powering

The Host Unit is powered by -48V DC through a DC power terminal block on the rear. An ON/OFF switch is provided at the PSU front panel. The switch applies power to the Host Unit internal power supply, which distributes the operating voltages to lines cards installed in the Host Unit shelf.

3.2.7 Host Unit Interface

The Host Unit interface consists of the various connectors, switches, terminals and LED indicators that are provided on the front and rear panel. The Host Unit user interfaces are described in Table 1 and indicated in Figure 9.

Table 1 Host Unit User Interface

#	User Interface Designation	Device	Functional Description
PSU			
1	ON/OFF	Power switch	Enable/disable Host Unit internal power supply
2	Power	LED(Green/Off)	Indicates if the PSU is powered on or off.
Note: The power input port is provided according to the power in type.			
RCU			
1	Modem (optional)	DB9(male)	Used for external wired modem connection
2	RS232 (optional)	DB9(female)	Local connection from PC/Laptop through serial cable
3	RJ45	RJ45 jack (female)	Ethernet connection interface for NMS
4	USB	Mini USB (female)	Used for USB connection for local GUI
5	Operate	LED(Green/Red)	Indicates if the RCU is normal or faulty
BIU			
1	Tx (700~2600)	QMA female connector	Band-specific Downlink input from BTS (one QMA per band, up to 5 bands)
2	Rx (700~2600)	QMA female connector	Band-specific Uplink output to BTS (one QMA per band, up to 5 bands)
3	Tx1~Tx4	QMA female connector	Combined multi-band Downlink signal output to up to four independent fiber paths (on FIUs)
4	Rx1~Rx4	QMA female connector	Combines multi-band Uplink signal inputs from up to four independent fiber paths (on FIUs)
5	Operate	LED(Green/Red)	Indicates if the BIU is normal or faulty
FIU			
1	Tx (1~2)	QMA female connector	Composite Downlink RF input from BIU
2	Rx (1~2)	QMA female connector	Composite Uplink RF output to BIU
3	Fiber (1~2)	E2000/APC WDM optical transceiver	Fiber connection to Remote Node (2 per FIU)
4	Operate	LED(Green/Red)	Indicates if the FIU is normal or faulty
Enclosure Rear Panel			
1	Alarm In	Screw-type terminal block	Alarm contacts - inputs from an external alarm system
2	Alarm Out	Screw-type terminal block	Alarm contacts – outputs to an external alarm system
3	DEBUG	DB19 male connector	Local serial connection for debug by BTI staff only

#	User Interface Designation	Device	Functional Description
4	Power Input	Screw-type terminal block	-48VDC power input
5	POI FAN (optional)	Screw type terminal	+12VDC for external power connection
6	NETWORK	RJ45 jack (female)	Optional Ethernet connection

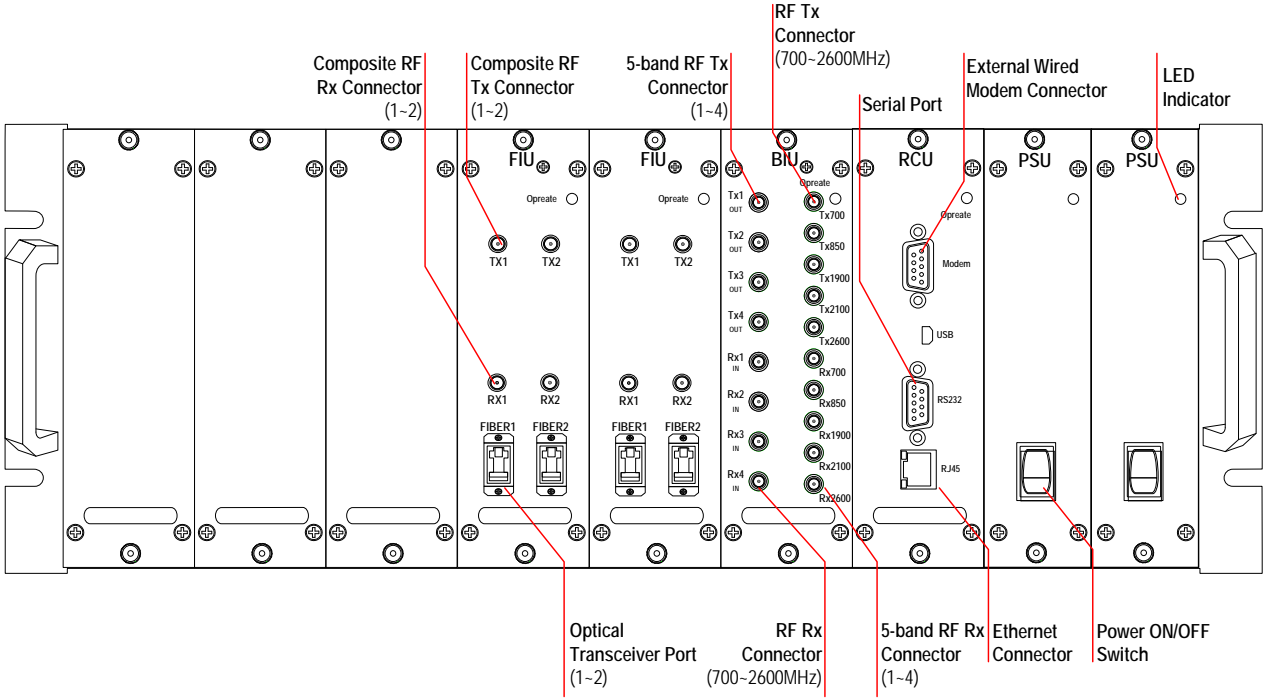

Front Panel

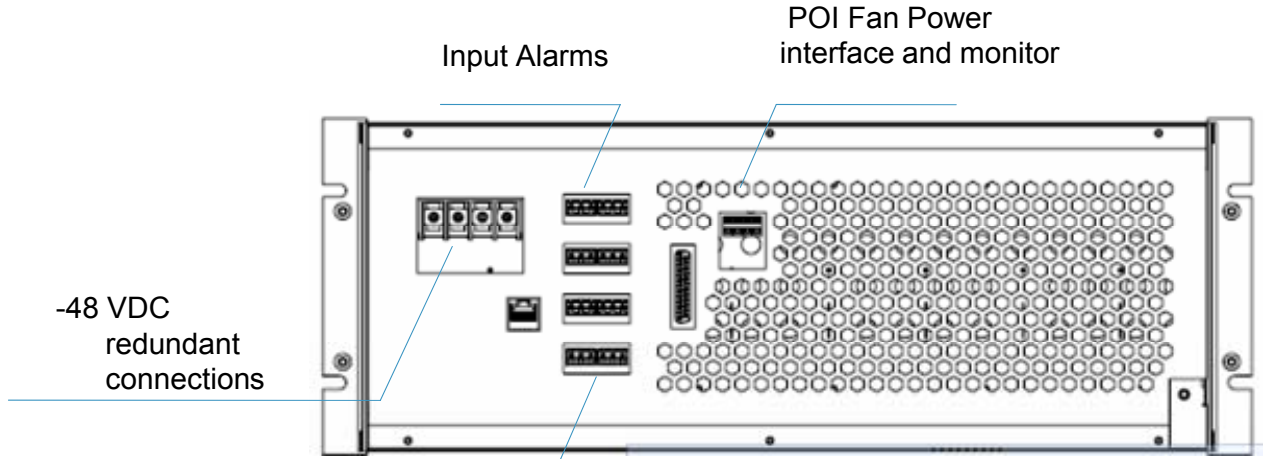

Dry Contact (Form C) alarm output

Rear Panel

Figure 9 Host Unit User Interface

Table 2 Host Unit Indicator Description

#	Indicator	Status	Description
1	RUN	Green(Flashing)	Normal system operation
		Red(Flashing)	System fault detected

3.3 Remote Node Description

The Remote Node serves as the remote interface unit for the fiber optic mBSC system. It is a multi-slot chassis and consisting of 12 slots numbered from left to right, enclosure for up to five RUMs (Remote Unit Module), RTM (Remote Transmission Unit), RPM (Remote Power Module), BCM (Band Combiner Unit) and Fan. The Remote Node provides the following basic functions:

- RF interface to the mobile end-systems via an external service antenna
- Optical interface to the Host Unit FIU
- Conversion of the forward path(downlink) optical signal to original RF signal
- Conversion of the reverse path(uplink) RF signal to an optical signal
- Transports alarm status over the optical fiber
- Supplies in-band messaging between the Host Unit and the Remote Node for Remote Node alarms and configuration

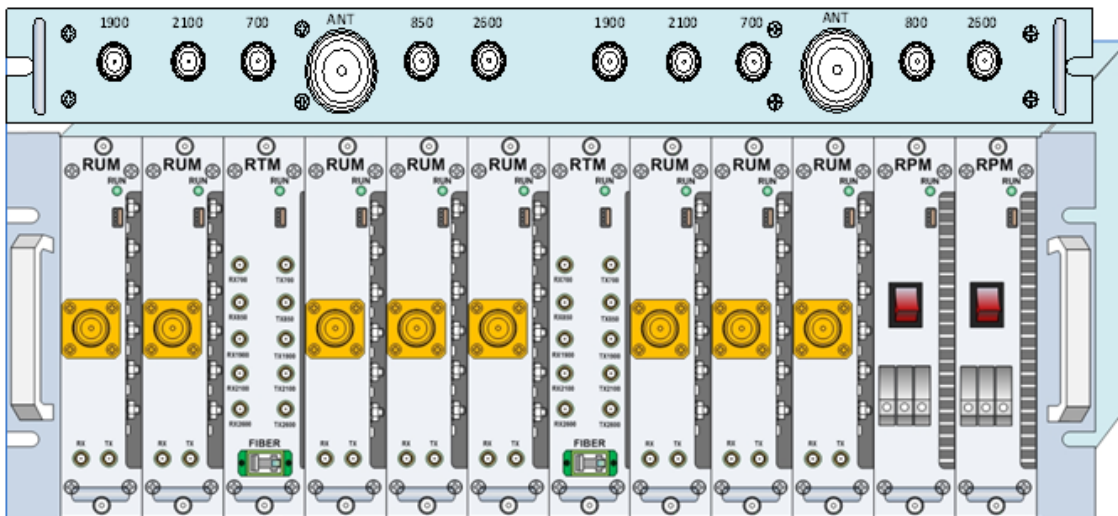

3.3.1 BCM Enclosure

The BCM module provides function:

Combines the RF signals from each single-band RU Enclosure for duplex interconnection with the service antenna

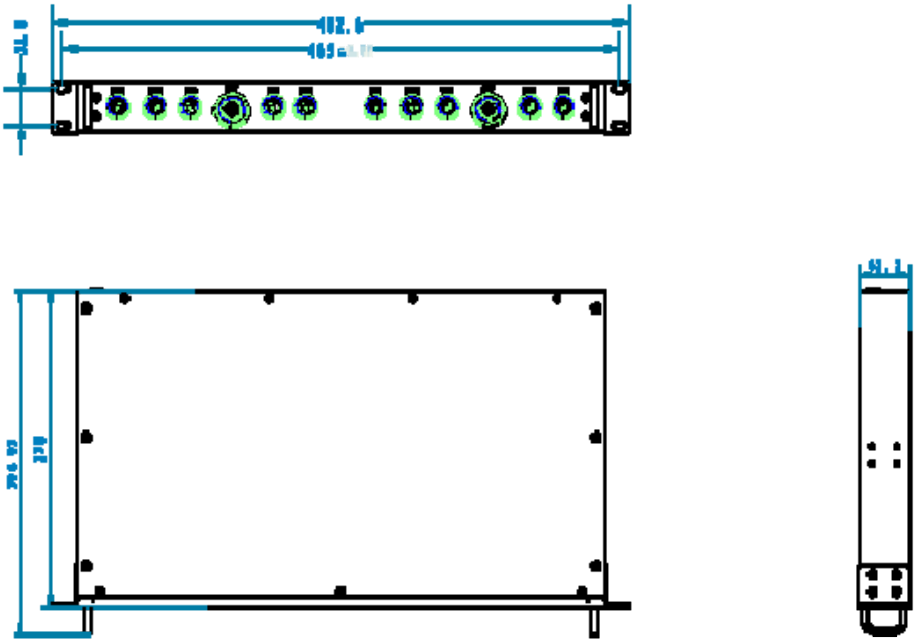

Figure 10 Fiber BCM Enclosure Outline

3.3.1.1 Primary Components

The fiber BCM enclosure interior layout, shown in Figure 11, is equipped to interface up to five bands (700MHz, 850MHz, 1900MHz, 2100MHz and 2600MHz).

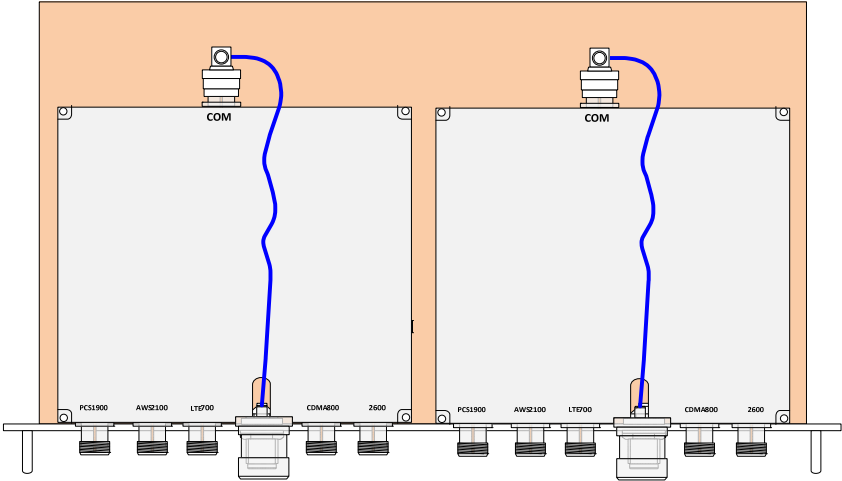

Figure 11 Fiber BCM Interior Layout

3.3.1.2 Multiplexer

The multiplexer separates the various band frequencies respectively. The duplexer is used to make the bi-directional signals into simplex signals and provides sufficient isolation.

3.3.1.3 Mounting

The BCM enclosure is installing on the 19" rack.

3.3.1.4 RF Connection

The RF signal connections with the antenna combiner are supported through 10 N-type female connectors. These ten N-type connectors are used for coaxial cable connection to the Antenna ports of the single-band RUM enclosures. Two 7/16 DIN connector is used to interface the combined multi-band RF signal to the service antenna.

3.3.1.5 User Interface

The BCM enclosure interface consists of the two kinds of connectors that are provided on the front panel. The BCM enclosure user interface is described in Table 3 and indicated in Figure 12.

Table 3BCM Enclosure User Interface

#	User Interface Designation	Device	Functional Description
Model BCM			
5	ANT	DIN female RF coaxial connector	RF duplex Tx/Rx connection to antenna
6	700~2600 TxRx	N female RF coaxial connector	RF duplex Tx/Rx inter-connection from ANT of single-band RU

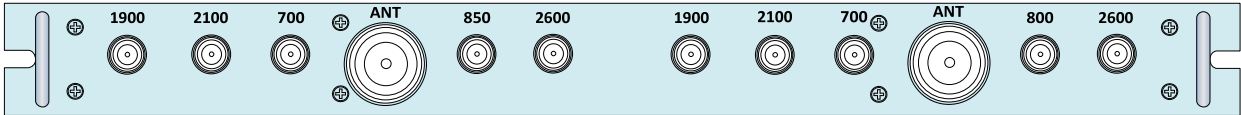

Combiner Model BCM

Figure 12BCM Enclosure User Interface

3.3.2 Single-band RUM Enclosure

The Single-band Remote Unit (RU) enclosure provides forward and reverse amplification of the RF signals within the specified band. Its enclosure accommodates the remote single-band modules and protects them from the environment. The enclosure consists of the housing, mounting brackets, and enclosed MCPA (Multi-Carrier Power Amplifier), controller unit, duplexer modules. Figure 13 shows the single-band enclosure dimensions.

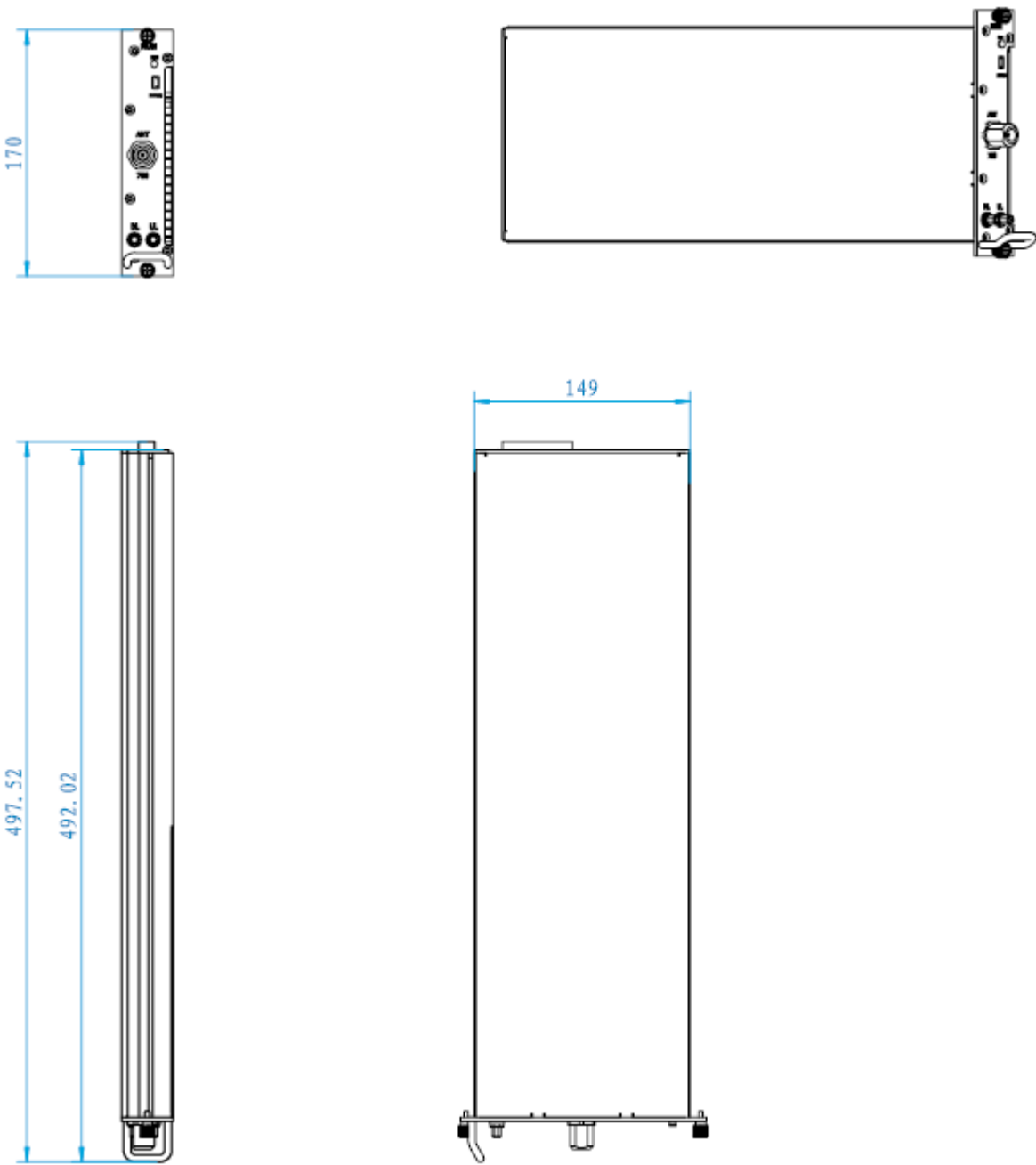
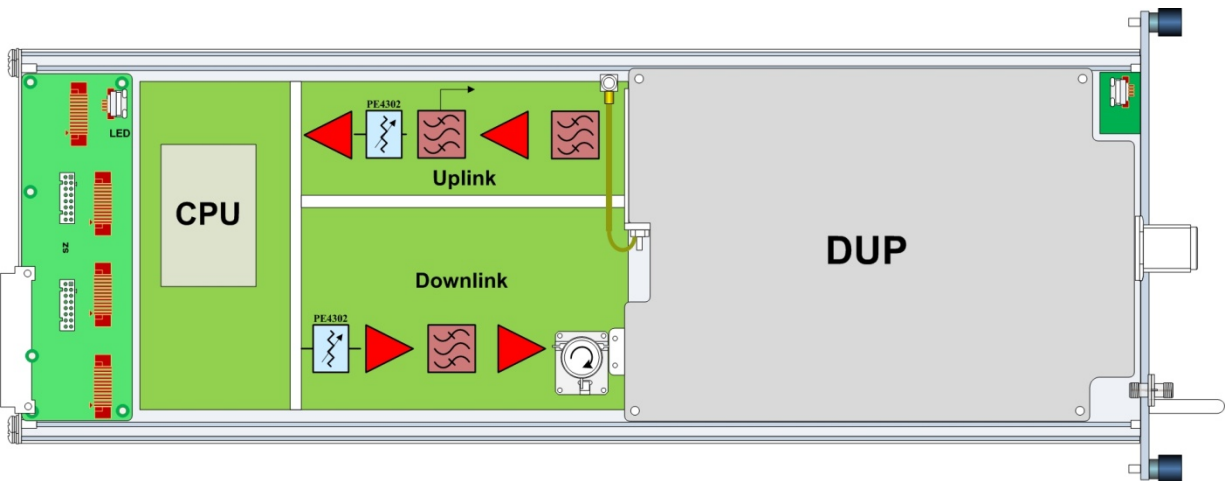

Figure 13 Single-band RU Enclosure

3.3.2.1 Primary Components



3.3.2.1.1 Multi-Carrier Power Amplifier (MCPA) Modules

The MCPA Module is the heart of the mBSC RUM Enclosure. The MCPA Module boosts the BTS forward link transmission signal. Operating on 28VDC input, the MCPA Module produces 5W composite RF power for each band (measured at output of the antenna combiner).

The mBSC system provides linear amplification of multi-carrier, mixed-mode signals in the 700MHz, 850MHz, 1900MHz, 2100MHz and 2600MHz frequency bands with the respective RU's.

3.3.2.1.2 Duplexer

The duplexer is used to make the bi-directional signals into simplex signals and provides sufficient isolation

3.3.2.1.3 CPU(Central Processing Unite)

The CPU provides communications and monitors with power amplifier module or other functional module.

3.3.2.2 Mounting

The single-band RUM enclosure is plug in REMOTE NODE multi-slot chassis.

3.3.2.3 RF Connection

The RF signal connections with the single-band enclosure are supported through two QMA female coaxial connectors and one N female connector. The two QMA female connectors are used for coaxial cable connection (RF jumper) of the Tx and Rx RF signals between the RTM enclosure and the single-band RUM enclosure. The N female connector is used for coaxial cable connection of the amplified duplex Tx/Rx RF signal to the BCM enclosure.

3.3.2.4 Cooling

The single-band RUM enclosure is cooled by cooling fans in the bottom of the casing. A minimum of 200mm (7.87 inches) of clearance space must be provided on both the top and the bottom sides of the Remote Node for air convection.

An alarm is provided that indicates if a high temperature condition occurs.

3.3.2.5 Powering

The single-band RUM enclosure is equipped with connector board in the bottom of chassis that provides a connection point for the DC power cable from RPM. The single-band RUM enclosure is powered by 28V DC.

3.3.2.6 User Interface

The single-band RUM enclosure user interface includes the various connectors that are provided on the exterior enclosure. The user interface is described in Table 4, and indicated in Figure 14.

Table 4 Single-band RUM Enclosure User Interface

#	User Interface Designation	Device	Functional Description
1	ANT	N type female RF coaxial connector	RF (Tx/Rx) inter-connection to BCM enclosure
2	DL/UL	QMA female coaxial connector	RF inter-connection to RTM
3	Debug	Mini USB connector	Support local debugging
4	RUN	LED (Green/Red/Off)	Indicates if unit operation is normal or faulty.

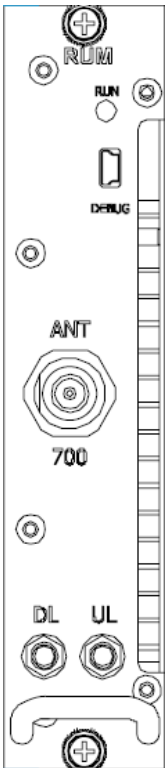

Figure 14 Single-band RU Enclosure User Interface

Table 5 Indicator Description

#	Indicator	Status	Description
1	RUN	Green(Flashing)	System operating normally
		Red(Flashing)	System alarm

3.3.3 RTM

The RTM module provides two key functions:

1. Electrical-optical/optical-electrical signal conversion and separates the combined multi-band RF signals into simplex connections for delivery to the respective single-band RU Enclosures
2. Combines the RF signals from each single-band RU Enclosure for duplex interconnection with the service antenna

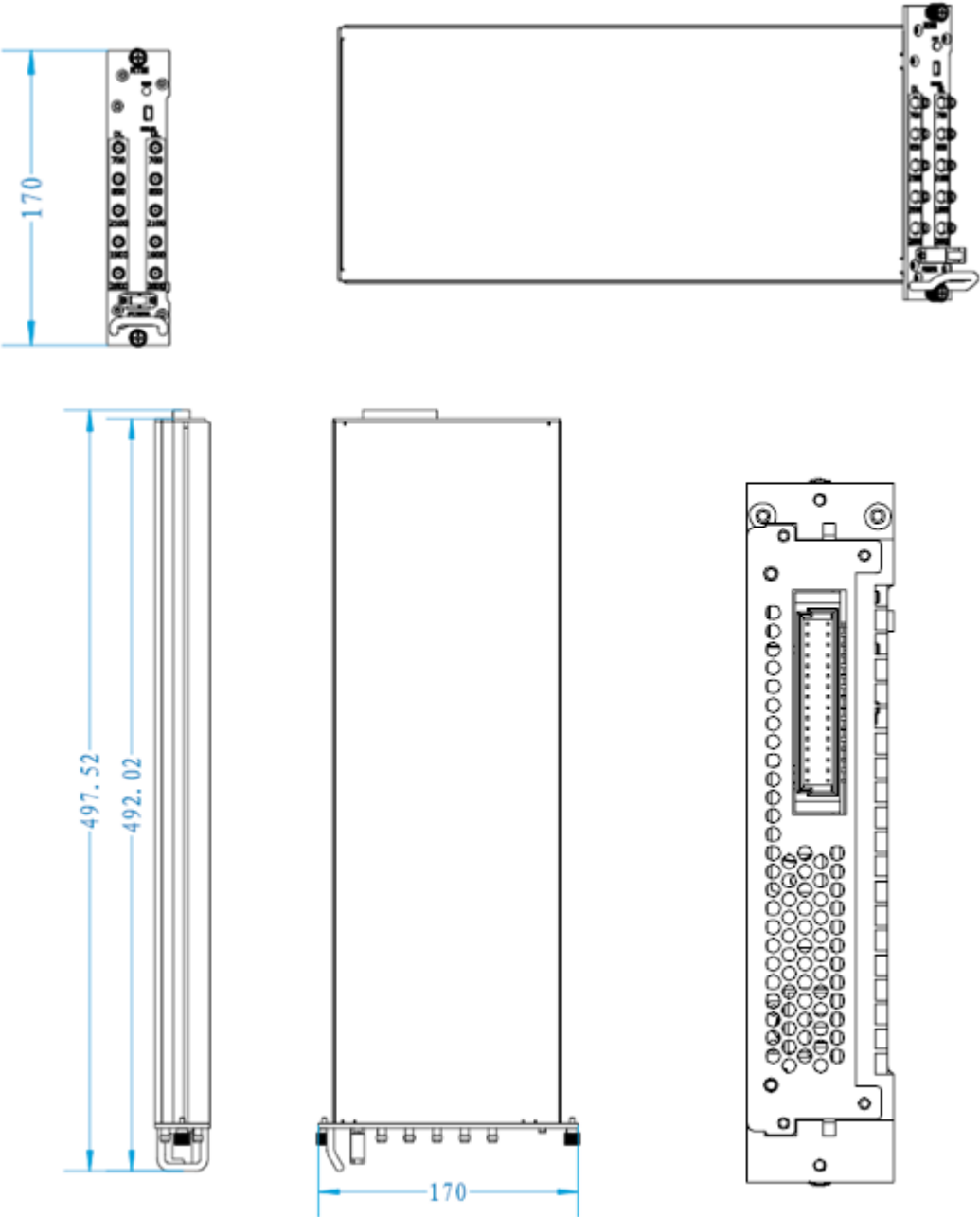

Figure 15 RTM enclosure

3.3.3.1 Primary Components

3.3.3.1.1 Optical Modules

The RTM enclosure interior layout, shown in Figure 11, is equipped to interface up to five bands (700MHz, 850MHz, 1900MHz, 2100MHz and 2600MHz). The enclosure includes weatherproof housing, plug in plug in CM multi-slot chassis and internal multiplexer, RF-optic transceiver, and control unit elements.

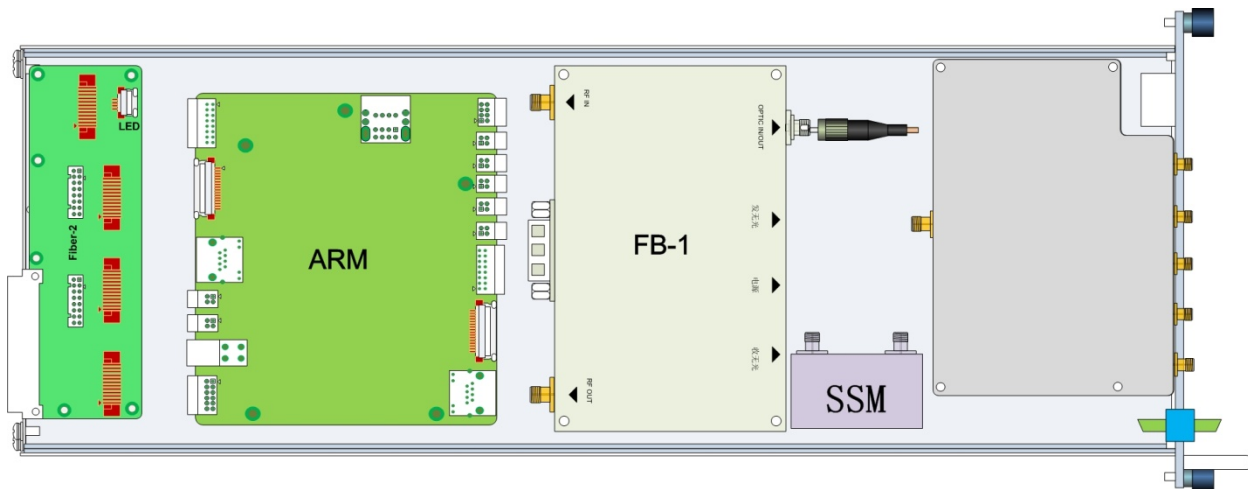

Figure 16 RTM Interior Layout

3.3.3.1.2 Multiplexer & Duplexer

The multiplexer separates the various band frequencies respectively. The duplexer is used to make the bi-directional signals into simplex signals and provides sufficient isolation.

3.3.3.1.3 RF-Optic Transceiver

The RF-Optic Transceiver is an optical module providing conversion between RF signals and optical signals over a single fiber. The optical module converts the downlink optical signal from the FIU module in the host unit, and it also converts the uplink RF signal to an optical signal and simultaneously sends it back to FIU module in the host unit for distribution to the BIU modules. A laser and received optical power monitor and alarm are provided.

Table 6 RF-Optic Transceiver Interface

#	Port	Device	Description
1	RF OUT	SMA female coaxial connector	RF output
2	RF IN	SMA female coaxial connector	RF input
3	OPTIC IN/OUT	E2000/APC	Fiber interface (HU & RN)
4	---	DB9 female	Power supply & monitoring

Table 7 DB9 PINOUTS

#	PIN	Definition	Description
1	PIN1	NC	
2	PIN2	GND	
3	PIN3	VCC	+12V DC
4	PIN4	TXD1/B1	Channel1: RS485-B1
5	PIN5	RXD1/A1	Channel1: RS485-A1
6	PIN6	RXD0/A0	Channel0: RS485-A0
7	PIN7	LD ALM	Laser Device error

#	PIN	Definition	Description
8	PIN8	TXD0/B0	Channel0: RS485-B0
9	PIN9	PD ALM	Photo-detector error

Table 8 RF-Optic Transceiver Indicators

#	Indicator	Status	Description
1	POWER	Green	Normal
		Off	No power supply
2	PD ALARM	Off	Photo-detector works
		Red	Photo-detector error
3	LD ALARM	Off	Laser Device works
		Red	Laser Device error

Notes: If the fiber is not connected properly, both of the HU and RN's PD ALARM indicator will alarm (red LED). Otherwise the indicator is off.

3.3.3.2 RF Connection

Optical Module: The RF signal connections with the optical fiber module are supported through 5 groups of QMA female connectors. These five connector groups are used for coaxial cable inter-connection of the simplex Tx and Rx RF signals to the single-band RUM enclosures.

3.3.3.3 Optical Port

The RTM enclosure uses anE2000/APC type optical transceiver for inter-connecting the optical fiber. The transceiver supports single-mode (yellow) fiber.

3.3.3.4 Powering

The RTM enclosure is equipped with connector board in the bottom of chassis that provides a connection point for the DC power cable from RPM.

3.3.3.5 User Interface

The RTM enclosure interface consists of the various connectors, terminals and LED indicators that are provided on the front panel. The RTM enclosure user interface is described in Table 3and indicated in Figure 12.

Table 9Fiber RTM Enclosure User Interface

#	User Interface Designation	Device	Functional Description
Model RTM			
1	Fiber	E2000/APC optical connector	Used for fiber connecting to host unit
2	RUN	LED (Green/Red/Off)	Indicates if Fiber/RF link is normal or faulty.
3	UL(700~2600)	QMA female RF coaxial connector	RF inter-connection to UL of RUM

#	User Interface Designation	Device	Functional Description
4	DL(700~2600)	QMA female RF coaxial connector	RF inter-connection to DL of RUM
7	DEBUG	Mini USB connector	Support Local debugging

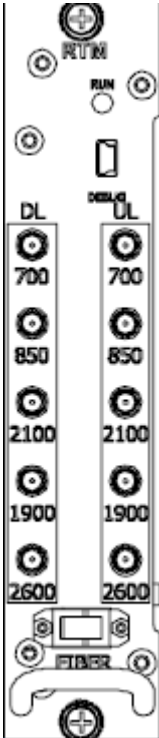

Figure 17 RTM interface

Table 10 Indicator Description

#	Indicator	Status	Description
1	RUN	Green(Flashing)	System operating normally
		Red(Flashing)	System alarm

3.3.4 RPM

The RPM provides 28V DC power connection and distribution to each enclosure.

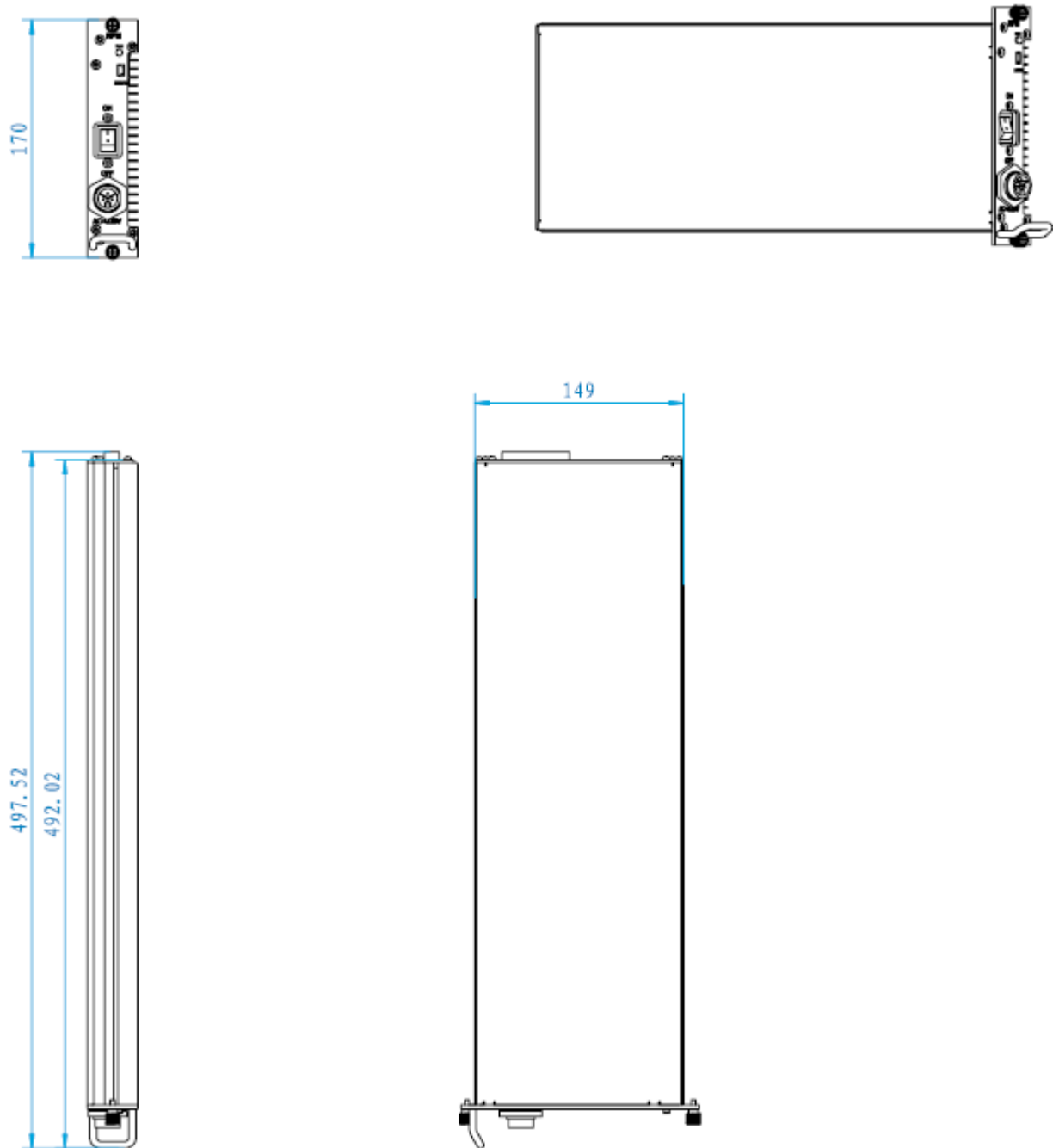

Figure 18 RPM Outline

3.3.4.1 Primary Components

The RPM enclosure interior layout, shown in Figure 11, is consists of power supply board, battery board, connector board and power control board. The enclosure plugs in plug in REMOTE NODE multi-slot

chassis.

3.3.4.1.1 Power supply board

The RPM enclosure is equipped with a 3-wire AC power connector that provides a connection point for the AC power cable. AC power input via power supply board convert to 28V DC distributed to RUMs and RTMs by connector board on the bottom of RPM enclosure.

Power supply board provides 28V DC to battery board and control board.

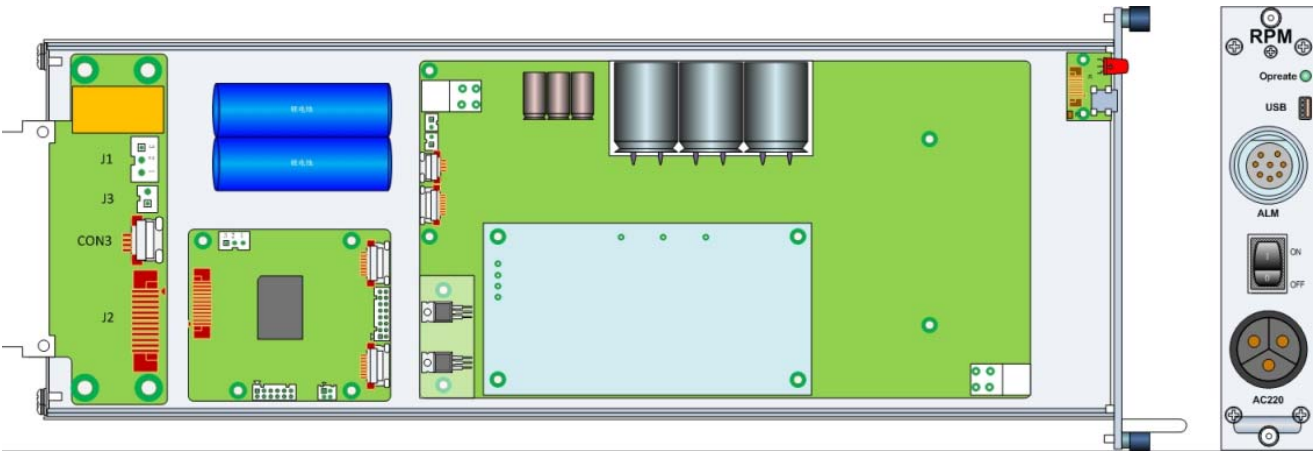

Figure 19 RPM interior layout

3.3.4.1.2 Control board

Control board manages power supply alarm and report to NMS.

3.3.4.1.3 Battery board

When power supply board stops working, then battery board will provides control board work.

3.3.4.1.4 Interface

#	User Interface Designation	Device	Functional Description
Model RPM			
1	Switch	Power Switch	Used for turn on/off power
2	RUN	LED (Green/Red/Off)	Indicates if Fiber/RF link is normal or faulty.
3	Alarm	8-PIN circular plug	Used for external alarm
4	AC 220V	3-wire circular push-plug power connector	Used for connecting AC 110/220V power input.
7	DEBUG	Mini USB connector	Support Local debugging

4 System Installation

4.1 Unpacking and Inspection

Every mBSC-C component has been tested and calibrated at the factory. Unpack the mBSC-C components carefully after they arrive at the installation site. Open the wooden container and remove the foam padding.

If the equipment is damaged:

- Immediately contact the transportation and notify them of the damage.
- A claim should be filed with the carrier once the extent of any damage is assessed.
- If possible, always inspect the equipment in the presence of the delivery person.

If the equipment is damaged and must be returned to BTI's nearest RMA facility:

- Log on the BTI website, or call 714-230-8333 for a return authorization.
- BTI will not accept returns without a RMA number.

Claims for loss or damage may not be withheld from BTI, nor may any payment due be withheld pending the outcome thereof.

BTI CANNOT be held responsible for the freight carrier's performance.

4.2 Installation Preparation

4.2.1 Required Tools

The following equipment and tools may be required for a successful installation:

- Multi-meter
- Phillips screwdrivers
- Flat blade screwdrivers
- Wrenches
- Drill
- VSWR testing device
- N adapters
- RF testing cables
- RF Power meter (part of hand-held tester)

4.2.2 Installation Location

The mBSC Host unit is typically installed within a 19" rack:

- The rack should be selected with adequate shelf space to accommodate the Host Unit equipment with adequate space for ventilation around each component
- The rack must be able to support the weight of the equipment to be installed

The mBSC Remote unit is typically installed on the wall:

- The wall should be water-resistant, dry, non-caustic and without high-voltage power leaking.
- The wall's bearing capacity is more than 136kg.
- Concrete wall sand brick walls are recommended, because those walls can accept expansion screws. Masonry walls or sandy-dust walls are not suitable.

4.2.3 Anti-corrosion and Shock-protection

To safeguard products and operators, the installation location must be kept away from caustic or poisonous pollutants. If the site can't meet seismic standards, it must be properly reinforced.

4.2.4 Lighting, Ventilation and Fire Protection

The installation site should have enough illumination for installation and maintenance needs. Flammable and explosive material should not be near the site.

4.2.5 Power Requirements

Nominal voltage:

- Remote Unit: 110/220VAC +/- 20%, 50/60 Hz +/-5%.
- Host Unit: -48VDC. Variable range: -36 ~ -72 V DC.

The power consumption of the mBSC Remote Node is approximately 220W per band. Make sure to select a fuse or breaker with the proper capacity. A 10A breaker is recommended @ 220VAC.

4.2.6 Lightning Protecting and Grounding

The cross section of grounding cable should be no smaller than 25mm². The grounding cable should be connected to earth ground directly without any splices. Keep the grounding cable as short as possible.

MBSC2500-005-RUCM11 system design complies with the criteria of IEC61000-4-5 and ETS 300 342-2/3.

4.3 Host Unit Installation

4.3.1 Rack Mounting

The Host Unit is a 19" 4U equipment shelf. When loading the Host Unit in a rack, make sure the mechanical loading of the rack is even to avoid a hazardous condition. The rack should safely support the combined weight of all the equipment and be securely anchored. Installing the Host Unit in a room with sufficient air circulation is recommended as the maximum ambient temperature for Host Unit is 60°C.

Use the following steps to install the Host Unit in the equipment rack:

1. The Host Unit is built with mounting bracket installed for 19" rack installation.

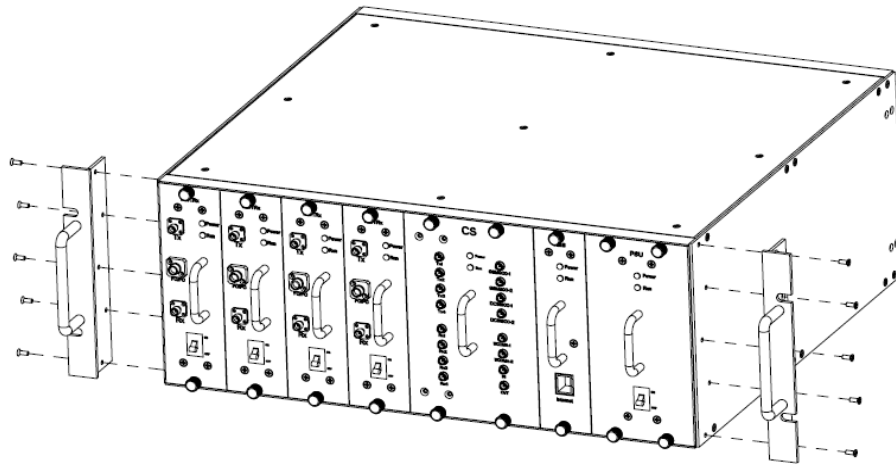

Figure 20 Mounting Brackets for 19" Rack Installation

2. Position the host unit in the designated mounting space in the rack as shown below.
3. Secure the mounting bracket to the rack using the four mounting screws provided.

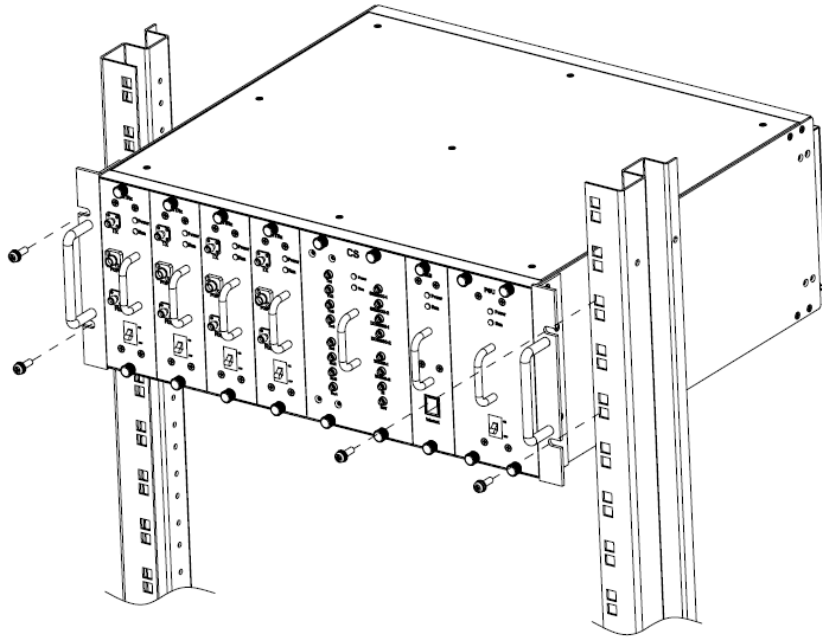

Figure 21 Host Unit-19" Rack Mounting View

4.3.2 Cable Connections

Note

The NEC (National Electrical Code) does not allow signal wires to share the same conduit with power wires unless the signal cable's voltage range is equal to the power wire's voltage range.

- Avoid bundling signal cable and grounding cable/power cable, keep them separate.
- The power cable and RF inter-connection cables are supplied.
- Check open and short circuits before installing the power cable.

4.3.2.1 Grounding

The host unit must be grounded. Do not connect external devices to the grounding connection.

Verify the host unit is securely grounded. If it is not securely grounded, use the following procedure to ground the host unit:

1. Find the screw at the bottom right corner of the Host Unit as shown in Figure 22.
2. Loosen the screw located on the grounding connection.
3. Connect the cabinet mounted earth-bonding cable between the two lock and flat washers as shown in Figure 23. Ensure the grounding surface is clean and free of paint, insulating material or contaminants.



Figure 22 Host Unit Grounding Stud

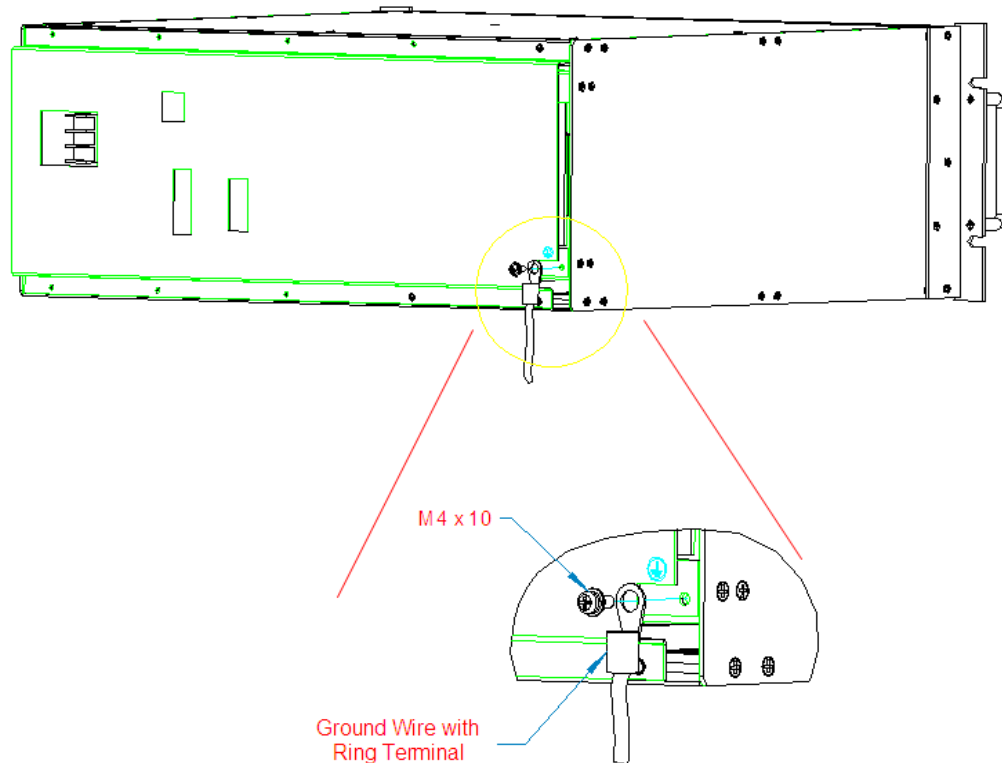

Figure 23 Grounded Host Unit

4. Tighten the screw, making sure the cable is securely connected before moving to the next phase of the installation.

4.3.2.2 Coaxial Cable Connections

The RF interface between the Host Unit and the BTS (or POI) is supported through Tx/Rx QMA female connectors mounted on the Host Unit front panel.

The Host Unit should be mounted as close as possible to the BTS to minimize RF cable losses. Use the

following steps to route and connect the simplex path coaxial cables to the Host Unit:

1. Obtain the required lengths of high performance, flexible, low loss 50Ω coaxial communication cable for all coaxial connections.
2. Route the RF Tx and Rx path coaxial cables between the Host Unit and BTS interface and cut to the required length.
3. Terminate the cable with a QMA male connector.
4. Connect the Tx and Rx cables from the BTS to the Tx and Rx connectors on the BIU front panel corresponding to the frequency band (e.g. Tx 700, Tx 850, Tx1900, Tx 2100 or Tx2600).



Figure 24 BTS QMA Coaxial Cable Connection

5. Dress and secure cable at the Host Unit.
6. The RF inter-connection between the BIU and the FIU uses QMA to QMA jumper cables supplied with the mBSC-C equipment.

4.3.2.3 Optical Connections

The optical interface between the Host Unit and the Remote Node is supported by an E2000/APC optical adapter which is mounted on the FIU front panel. A single mode, E2000/APC patch cord may be used to connect the Host Unit with Remote Node.

Use the following steps to connect the optical fibers:

1. Obtain one patch cord which is sufficient length to reach from Host Unit to the Remote Node.
2. Clean each patch cord connector following the patch cord supplier's recommendation.
3. Push and secure the patch cord connector into the desired optical port on the Host Unit FIU



Figure 25 Single Mode Patch Cord (E2000/APC)



Figure 26 E2000 Fiber Optic Port on Host Unit FIU

4. Route the patch cords from the Host Unit to the Remote Node.
5. Connect optical fiber to the Remote Node RTM fiber port.

4.3.2.4 DC Power Connection

The DC power interface of the Host Unit is provided by a 2-wire termination located on the HU rear panel. The DC termination provides a connection point for the power cord which is provided separately with the HU. Use the following procedure to install the DC power:

1. Locate the 48 VDC power cord which is provided separately with the HU.
2. Place both HU PS module power ON/OFF switches in the OFF position.
3. Connect one end of the power cord to the DC termination on the HU.
4. Connect the other end of the power cord to the 48VDC source.
5. Dress and secure cable per standard industry practice.



Figure 27 48VDC Host Power Connection

4.3.2.5 Local OMC Computer Connection

The primary communication interface between the mBSC system OMC and a local computer is provided by a single RJ45 jack on the front panel of Host Unit (note: the USB port of the RCU card can also be used to access the local OMC port). All the connected Remote Nodes can be monitored at the Host Unit side through the fiber connection. The communication connector supports an IP interface. A CAT5 cable is used

for connecting the local computer to the mBSC Host Unit OMC interface.

To connect the OMC computer with the Host Unit:

1. Obtain the required length of CAT5 twisted pair cable with RJ45 connectors.
2. Route the cable between the OMC computer (or local switch/router) and Host Unit.
3. Connect the cable to the RJ45jack on the front panel of Host Unit RCU.
4. Connect the other end of the cable to the RJ45 jack on the OMC computer or local switch/router.

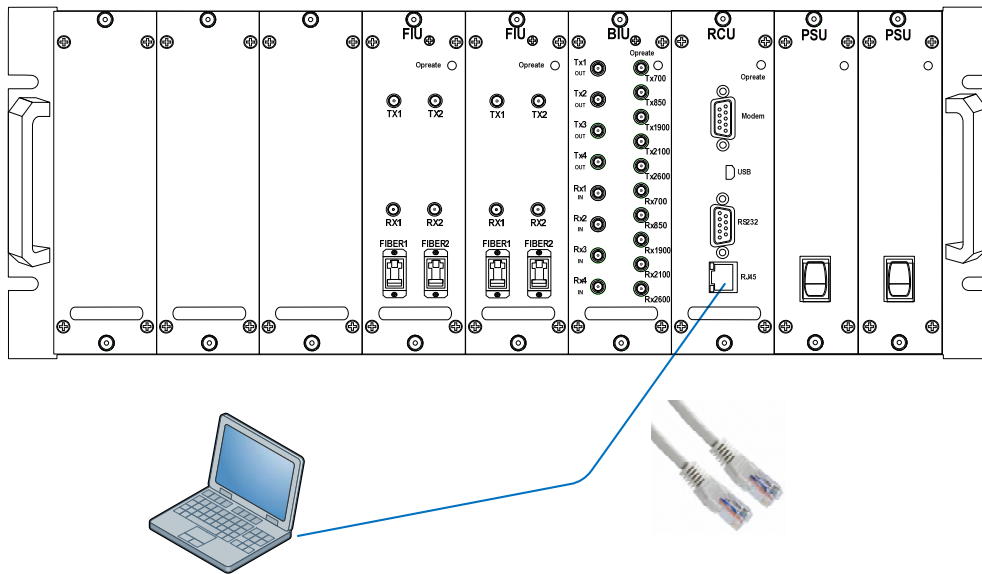

Figure 28IP Connection for local GUI Control

4.3.2.6 Modem Connection (optional)

For remote operation, the mBSC-C system provides a serial modem connector for external modem connection.

To connect a modem with the host unit:

1. Route the modem cable between the modem and host unit.
2. Connect the modem cable with a DB9 female plug to the modem socket on the host unit's RCU front panel.

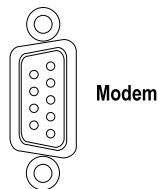

Figure 29Modem Port on RCU (DB9 male)

3. Connect the modem cable with DB9 male plug to the modem serial port.

4.4 Remote Node Installation

The remote unit is a 19" 4U equipment shelf. When loading the remote unit in a rack, make sure the mechanical loading of the rack is even to avoid a hazardous condition. The rack should safely support the combined weight of all the equipment and be securely anchored. Installing the remote unit in a room with sufficient air circulation is recommended as the maximum ambient temperature for remote unit is 60°C.

remote unit install as same as HU device. Please refer to chapter 4.3.1.

4.4.1 Cable Connections

 **Attention**

All the power switches must be switched off before cable installation.

- Avoid bundling signal cable and grounding cable/power cable, keep them separate.
- The power cable and RF inter-connection cables are supplied.
- Check open and short circuits before installing the power cable.

4.4.1.1 Coaxial Cable Connections

The simplex low-power RF interface between the RTM enclosure and the single-band RUM enclosures is supported through RF QMA female connectors mounted on the enclosure panel. The duplex high-power RF interface between the single-band RU enclosures and the BCM enclosure, and to the service antennas, is supported through Nfemale connectors mounted on the enclosure panel.

4.4.1.1.1 BCM to Single-band RU

To connect the coaxial cable between BCM enclosure and single-band RU enclosure:

1. Obtain the required lengths of high performance, flexible, low loss 50Ω coaxial communication cable for all coaxial connections.
2. Route the RU ANT and BCM N connector coaxial cable between the BCM enclosure and single-band enclosure interface and cut to the required length.
3. Dress and secure cable.

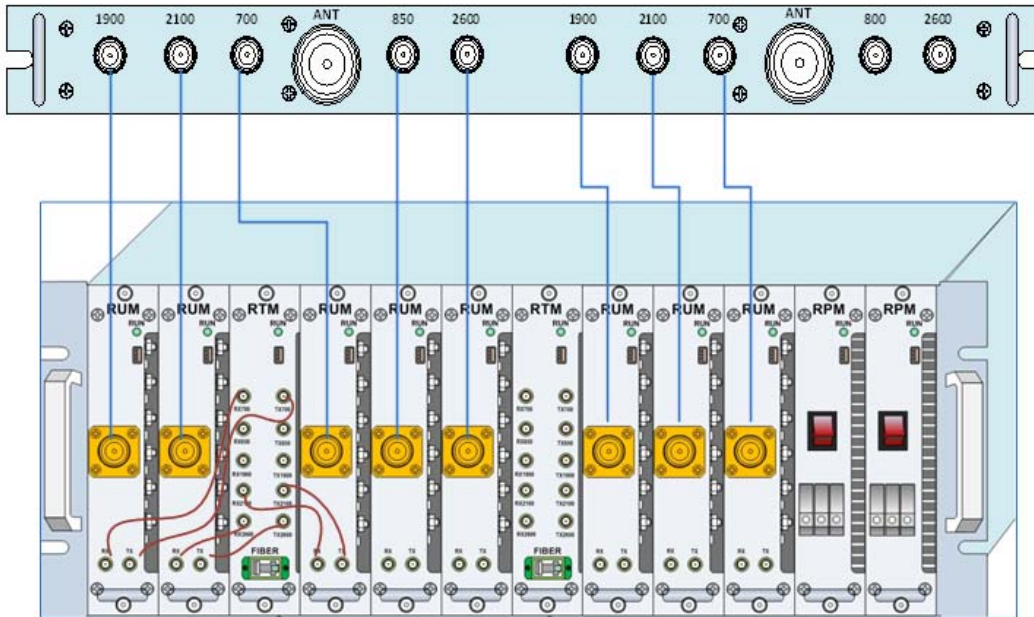

Figure 30 RF Inter-Connect between BCM and Single-band RU

4.4.1.1.2 Single-band RUM to RTM

To connect the coaxial cable between RTM enclosure and single-band RUM enclosure:

1. Obtain the required lengths of high performance, flexible, low loss 50Ω coaxial communication cable for all coaxial connections.
2. Route the RF UL/DL path coaxial cable between the RTM enclosure and single-band RUM enclosure interface and cut to the required length.
3. Connect the UL/DL cable to the designated UL/DL connector on the panel of RTM enclosure and the panel of the single-band RUM enclosure.
4. Dress and secure cable.

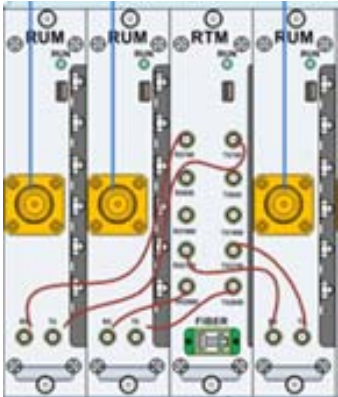

Figure 31 RF Inter-Connect between RTM and Single-band RU

4.4.1.2 Antenna Cable Connection

Route a coaxial antenna cable from the antenna to the equipment enclosure. The cable must be terminated with the proper connector for connecting to the antenna port on the panel of BCM enclosure.

Below is the procedure to install the antenna cable:

1. Remove the dust cap from the DIN type female connector located on the panel of the BCM enclosure.
2. Route the coaxial antenna cable to the panel of the BCM enclosure panel.
3. Cut the antenna cable to the required length and terminate with the proper connector.
4. Connect the antenna cable to the BCM port.

Antenna Port Matching Device(Recommend):

Matching Device	Device Designation	Proposed Class
Cable	Type-N Connector, RF Cable	More than 1/2" RF coaxial Cable, Support more than 50w peak power
Coupler	Type-N or DIN Connector	Recommend more than 50w peak power coaxial or microstrip coupler
Antenna	Applicable to various types of supports TDD 2.5 GHz frequency band of directional or omni-directional antenna of the radio frequency; Recommend Type-N or DIN Connector Antenna. Model: commscope (3X-V65A-3XR)	Support more than 50w peak power antenna of operation Frequency

4.4.1.3 Optical Connections

The optical interface between the RTM enclosure and the Host Unit is supported by duplex Tx/Rx optical port(s). Each optical port consists of aE2000/APC optical adapter which is mounted on the RTM enclosure panel. A single mode, E2000/APC patch cord may be used.

Use the following steps to connect the optical fibers:

1. Obtain one patch cord which is sufficient length to reach from fiber optic distribution box to RTM panel.
2. Remove the dust caps the optical ports and from the patch cord connectors that will be connected.
3. Clean each patch cord connector following the patch cord supplier's recommendation.
4. Screw-thread secures the patch cord connector into the optical port on the fiber optic distribution box.

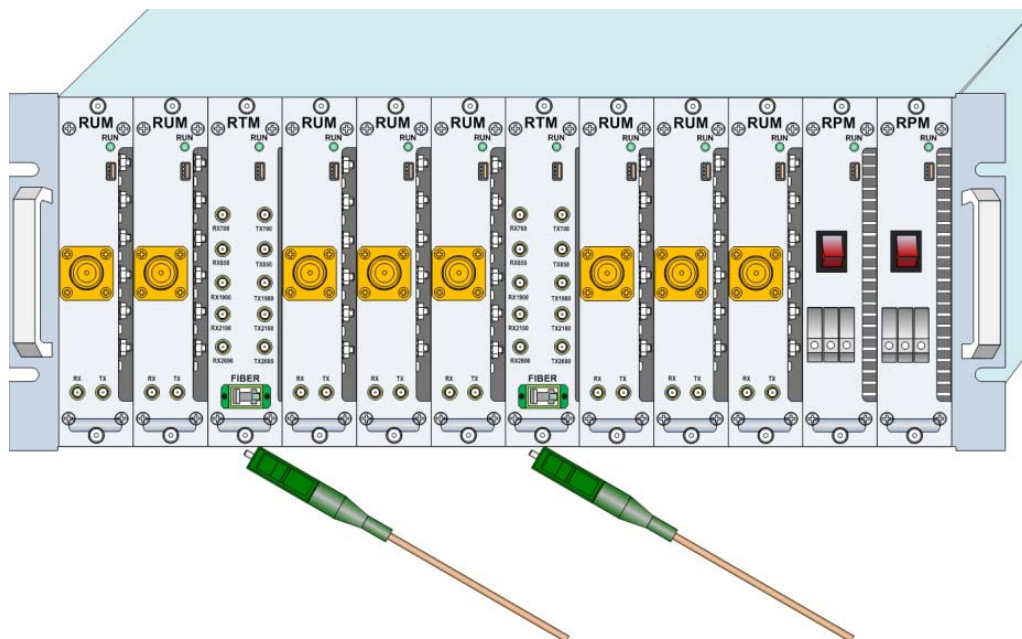

Figure 32 Fiber Optic Cable Connection to RTM Enclosure

5. Route the patch cords from the fiber optic distribution box to the designated optical port on the panel of the RTM enclosure.
6. Identify each optical fiber.

4.4.1.4 AC Power Connection

⚠ Danger

Use extreme caution when working with high voltage AC power. Ensure all power is disconnected before working on power circuit.

⚠ Warning

Verify that the unit has been ground with an earth-bonding cable to the grounding connector.

A connectorized 3-wire power cable is provided with the RPM enclosures for the AC power connection, as shown in this manual. The connectorized end of the power cable connects to the AC power port located on the panel of the enclosure.

The AC power source must supply 110/220V AC(+/-20% @50/60Hz) through a 15 Amp circuit breaker. The AC power cable provides the wire leads for line, neutral and ground connections. The power cable must be routed from the cabinet to an electrical junction box for connection to the AC power source. The power cable is rated for indoor or outdoor use. Refer to the following procedure to install the AC power wiring:

1. Locate the RPM which is located at the multi-slot chassis of the Remote Node unite as shown in Figure 33.



Figure 33 RPM

2. Terminate the AC power supply wires that are required between the RPM and the local source of AC power.
3. Tighten the coupling nut.

4.5 Installation Final Inspection

The following section provides a set of review procedures once the physical installation and connections are complete. Leave the source AC power at the Host Unit and Remote Node in the OFF position (breaker open) to prevent accidental power-up.

4.5.1 Host Unit Connection Overview

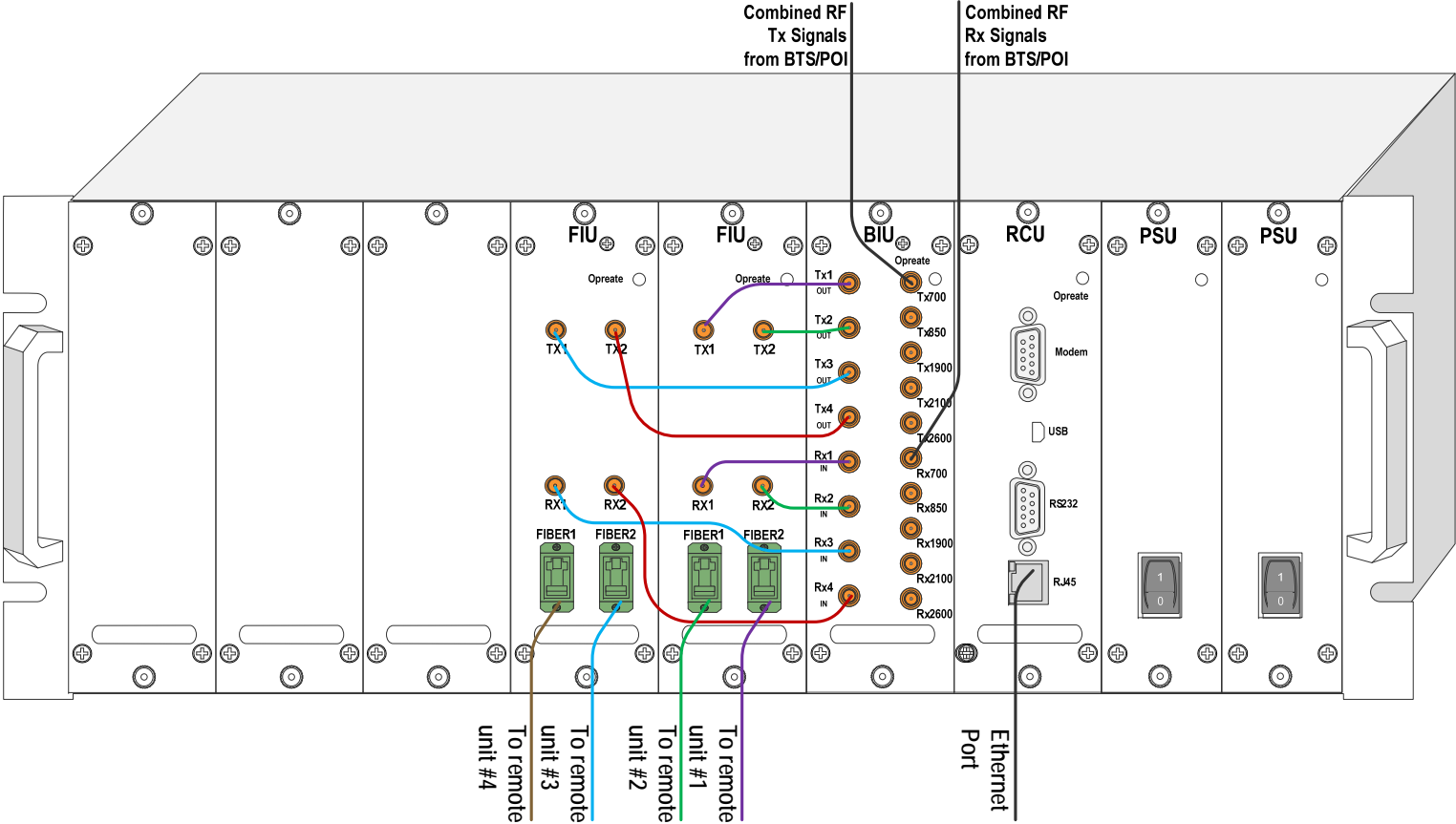
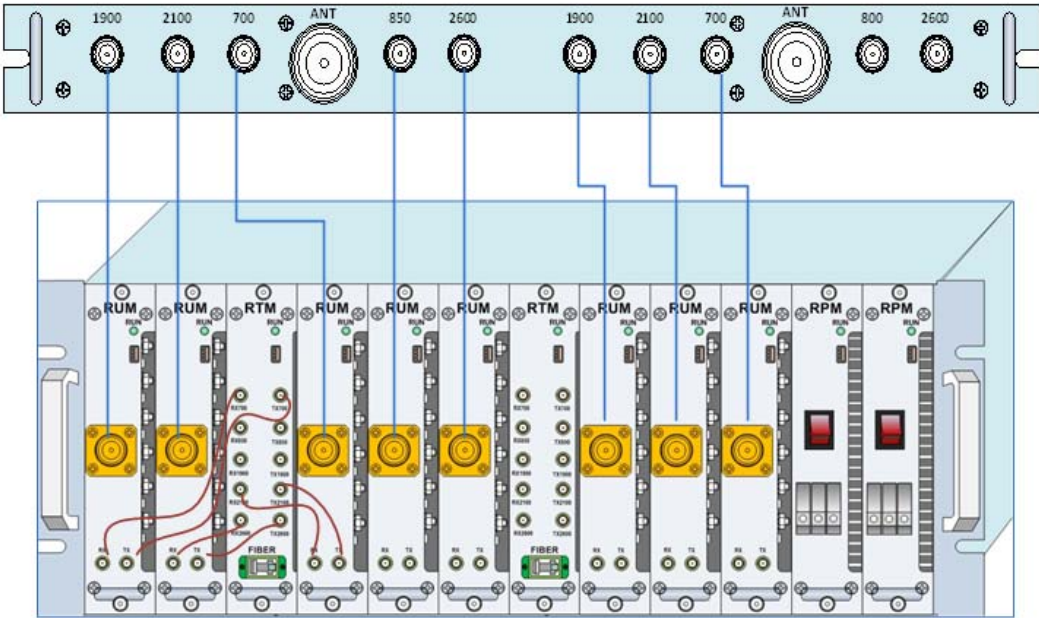

Figure 34 Host Unit Connection Overview

4.5.2 Remote Node Connection Overview



Interconnection with Combiner Model BCM

Figure 35 Remote Node Inter-Connection Diagram

4.5.3 mBSC-C Inspection Checklist

Table 11 mBSC Unit Inspection

Item	Description
1	Stable and normal.
2	Properly fastened
3	Screws and nuts screwed tightly, without missing flat washers and spring washers. Spring washers must be on the top of flat washers.
4	No cable damage.
5	Clean, no smudges or dust.
6	Connections between metallic parts must be reliable, to assure reliable electric connectivity.

4.5.4 Cabling Inspection

Table 12 Cable Inspection

Item	Description
1	The connection of the cable is tight, not loose or damaged.
2	The cable shell not damaged.
3	Grounding cable is connected properly.
4	Cables are dressed neatly, power kept separate from signal.
5	The minimum bending radius of the cable is proper. (Shouldn't be less than twenty times of the cable's diameter.)

4.6 System Test

It is recommended to perform a system test after the physical installation and cabling has been inspected and verified.

Use the following procedure to perform the system test:

- Configure the attenuation both of the forward path and reverse path
- Configure the parameters of Host Unit
- VSWR testing: sweep test of cables and antenna
- Configure the parameters of Remote Unit
- Signal testing: indoor signal level testing
- Effect testing: CQT/DT testing
- Coverage Optimize: based on the signal & effect testing result, adjust the mBSC parameters to optimize the coverage



Figure 36 Flow Chart of System Debugging

5 System Monitoring & Configuration

5.1 Accessing EMS Local GUI

The MBSC2500-005-RUCM11 system supports local configuration through a web-based Element Management System (EMS) graphical user interface (GUI) accessed through the RJ-45 and USB ports of the Host Unit RCU card. The EMS local GUI is a web-based application supported by standard web-browsers. Microsoft Internet Explorer® is recommended.

System configuration and monitoring can also be performed from a remote EMS Server. The EMS Server is a multi-user platform that includes enhanced management capabilities for configuration, monitoring and alarming. The EMS Server is required to generate SNMP alarms.

Note: It may take up to 3 minutes for the mBSC system to initialize, therefore it is recommended to only attempt to login to the GUI after the mBSC system has completely started, otherwise the GUI may incorrectly display a message indicating that the username and/or password are wrong (when in fact they may be correct).

5.1.1 Using Ethernet Port

Access to the EMS Local GUI through an RJ-45 Ethernet connection is provided on the RCU card in the Host Unit shelf. The Ethernet port is the primary point of connection for the remote EMS Server. The EMS Local GUI accessed through the Ethernet port is assigned the IP address 172.18.60.60 at the factory. However, this IP address can be modified to suit the networking requirements of the installation (e.g. to allow access across a Local Area Network).

Steps:

1. Obtain a CAT5 cable and connect it to the RJ45 port on the host unit RCU card, and connect the other end into the RJ45 port on the laptop/computer. Depending on the model year of your computer, a crossover cable may be required.
2. Start an Internet Explorer browser session on the laptop/computer, and enter the following URL to connect to the Local GUI—"http://172.18.60.60".

Note: The mBSC system does not provide DHCP service. To access the GUI you will need to configure the local computer with a static IP address the same subnet as the local GUI.

Note: The EMS Local GUI is a single-user interface, and supports only a single user at a time. If the Ethernet interface is connected to a Local Area Network, and more than one user is accessing the EMS Local GUI at the same time, inconsistent operation may occur. Please use the EMS Server for multi-user applications.

5.1.2 Using USB Port

Access to the EMS Local GUI through a standard USB connection is also available at both the Host Unit RCU card, and the RTM enclosure of the Remote Node. The EMS Local GUI has a fixed IP address assignment when accessed through the USB port – it is set at the factory and cannot be changed.

Steps:

1. Install the USB-Ethernet driver on the laptop/computer. **The laptop/computer must be connected to the internet in order for the drivers to be automatically installed.**
2. Obtain a USB cable and connect it to the USB port on the host unit and the laptop/computer.
3. Start an Internet Explorer browser session on the laptop/computer, and enter the following URL–“http://192.168.5.220”.

<p>Note: The mBSC system does not provide DHCP service. To access the GUI you may need to configure the local computer with a static IP address the same subnet as the local GUI.</p>
--

5.1.3 Login to EMS Local GUI

Access the EMS Local GUI as follows:

- 1. Type the appropriate URL into the browser (e.g. <http://192.168.5.220> for USB port). The dialog box shown in Figure 37– EMS Local GUI Login will appear.
- 2. **User name:** Type in the user name provided for you to access the system (default = “admin”)
- 3. **Password:** Type in the password provided for you to access the system (default = “”)
- 4. Click **Login**



Figure 37– EMS Local GUI Login

The default user account for the EMS Local GUI is set at the factory as follows:

Table 13 Local GUI Default User Accounts

Username	Admin
Password	(null)
Access Control Level	Equipment properties view Gain setting

The mBSC system administrator may have created different usernames and passwords for you to use.

5.2 Navigating the EMS Local GUI

When logged in to the EMS Local GUI, it displays the main page as shown in Figure 38. On the left side of the main page the topology of the mBSC-C system you are connected to is automatically displayed. This includes the Host Unit and the fiber attached Remote Nodes. On the right side is a floating window for displaying system component properties.

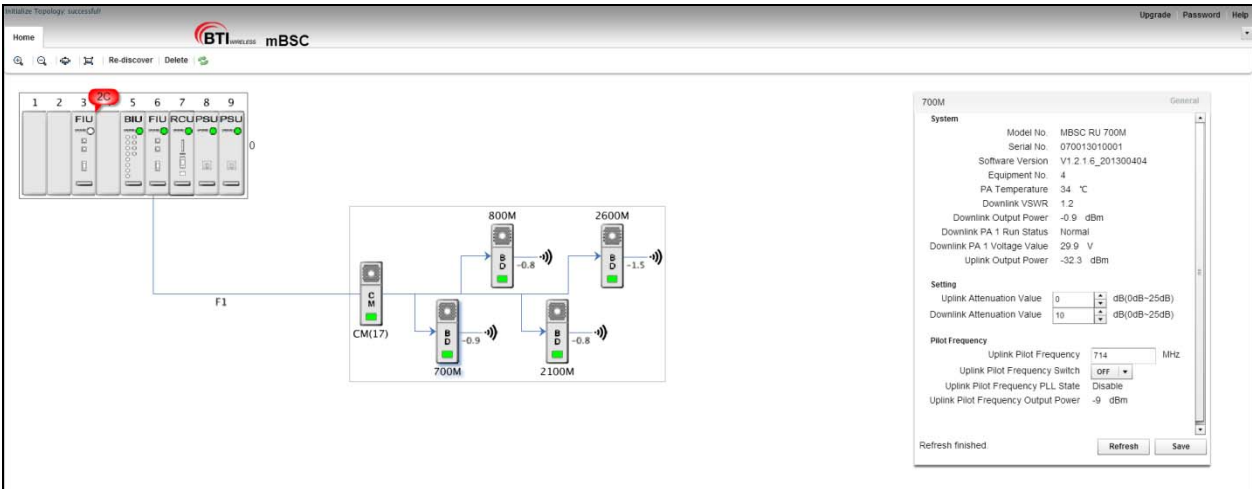

Figure 38- Main Page Expanded Topology

Note: The EMS Local GUI will only display the nodes that are connected to the specific Host Unit shelf that you are connected to. If the site has multiple Host Unit shelves (to support many Remote Nodes) then you will need to separately connect to each shelf to perform configuration. The EMS Server, if provided, will enable connections to multiple connected Host Unit Shelves and multiple installation sites.

In the topology window the system can be placed into a summary view by double-clicking on the Host Unit shelf, or the Remote Node components.

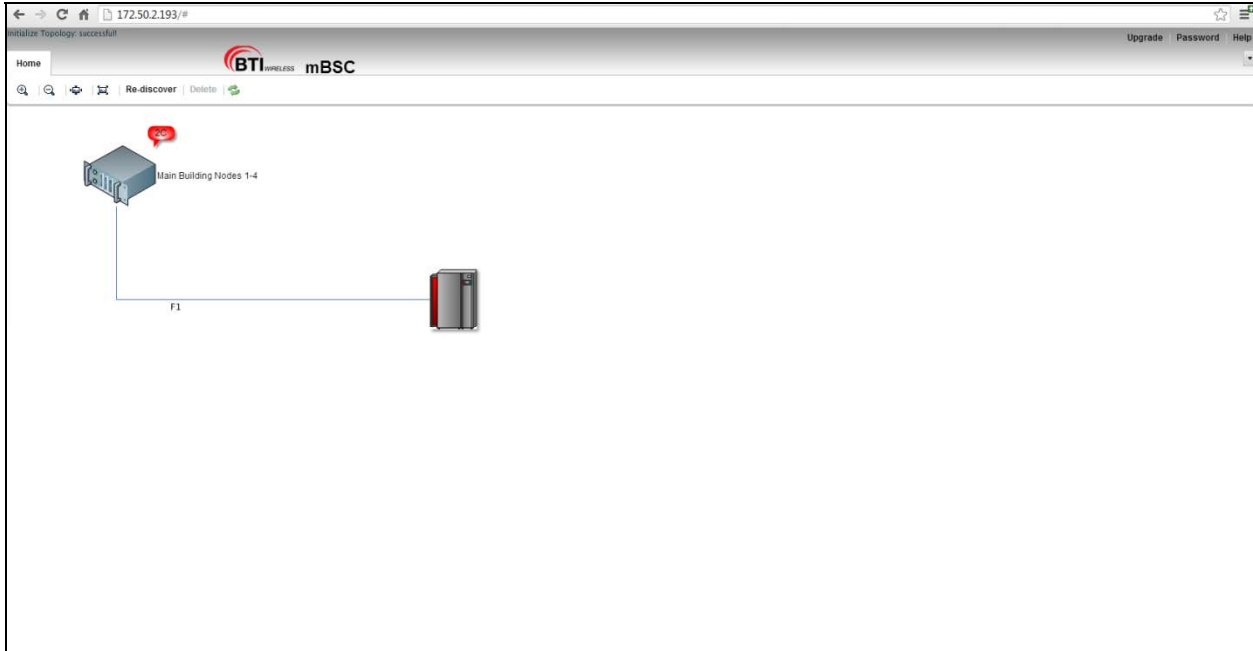

Figure 39- Main Page Summary View

5.2.1 Topology Tool Bar

Various functions can be performed by clicking on the following icons.

Table 14 Tool Bar Functions

Tool	Function
	Zoom in – Zooms in the topology diagram
	Zoom out – Zooms out the topology diagram
	Reset – Resets the topology view to default
	Overview – Resizes topology diagram to full screen
Re-discover	Re-Discovery – Constructs the topology upon initial local GUI login or changes in system configuration. This function is crucial to make sure topology structure is correct.
Delete	Delete – Deletes a component from the Topology view
Refresh	Refresh – Refreshes “real time” system topology

5.2.2 Upgrade/Password Functions

The links in the upper right corner contain the **Upgrade**, **Password**, and **Help** functions.

Table 15 General GUI Tools

Function	Description
Upgrade	Perform a component software upgrade
Password	Change the login password for current User
Help	System information and Help

5.3 Installation & Configuration

5.3.1 Network & Communications

5.3.1.1 Change IP Address of RCU Ethernet port

In order to connect the RCU to a Local Area Network (for example, to allow remote access to the mBSC from outside the Site) the user will need to change the IP address to the address required in their existing network.

To change the IP address of the RCU Ethernet Port:

1. Click on the RCU in the topology diagram and the component window will pop up on the right as shown in Figure 40- RCU Component View.
2. Locate the required fields and set the appropriate values.
 - a. Mode of Communication: must be set to Ethernet
 - b. Equipment IP Address: enter the value assigned to this HU shelf
 - c. Equipment Subnet Mask: enter appropriate subnet mask
 - d. Equipment Default gateway: enter assigned gateway
3. Click **Save**

RCU(0)		General
Model No.	mBSC-c-rcu-us-inte	
Serial No.	12141604610113010001	
Software Version	V3.0.1.9_1304041122	
Equipment No.	0	
System Temperature	45 °C	
Site Name/Number Info	Main Building Nodes 1-4	
Setting		
Mode of Communication	Ethernet ▼	
Site No.	96	
Query/Set Phone Number 1	0000000000000	
Report Phone Number		
NMS IP Address(IPv4)	172.50.2.192	
NMS IP Port	8008 ▲▼	
Query/Set IP Address 1	172.16.7.135	
Query/Set IP Address 2	172.16.7.136	
Equipment IP Address	172.50.2.193	
Equipment MAC Address	000000000000	
Equipment Port No.	7001	
Equipment Subnet Mask	255.255.0.0	
Equipment Default Gateway	172.50.1.1	
Refresh finished.		
		Refresh Save

Figure 40- RCU Component View

5.3.1.2 Assign IP Address for Remote EMS Server

The mBSC-C system can also be managed from a remote EMS Server. To communicate with the remote server the IP address must be reachable from the local network, and must be configured within the RCU.

To assign the IP address of the remote EMS Server:

1. Click on the RCU in the topology diagram and the component window will pop up on the right as shown in Figure 40- RCU Component View.
2. Locate the required fields and set the appropriate values.

- a. NMS IP Address(IP4): enter the value assigned to the remote EMS Server
 - b. NMS IP Port: enter port (default value is 8008)
 - c. Equipment Default gateway: enter assigned gateway
3. Click **Save**

5.3.1.3 Assign HU Site Name/Number

Users can create a name or a site number for the Host Unit. This information is displayed in the Summary View (Figure 39- Main Page Summary View), or is used in the EMS Server to distinguish between multiple Host Shelves and/or multiple mBSC systems.

To assign the HU Site name/Number:

1. Click on the RCU in the topology diagram and the component window will pop up on the right as shown in Figure 40- RCU Component View.
2. Locate the required fields and set the appropriate values:
 - a. Site Name/Number Info: enter the desired identifier
3. Click **Save**

5.3.2 System Installation

5.3.2.1 Verify Component Status

Once the system has been properly installed, check the status of each component in the Home tab, as shown in Figure 41- Main Page Equipment Status.

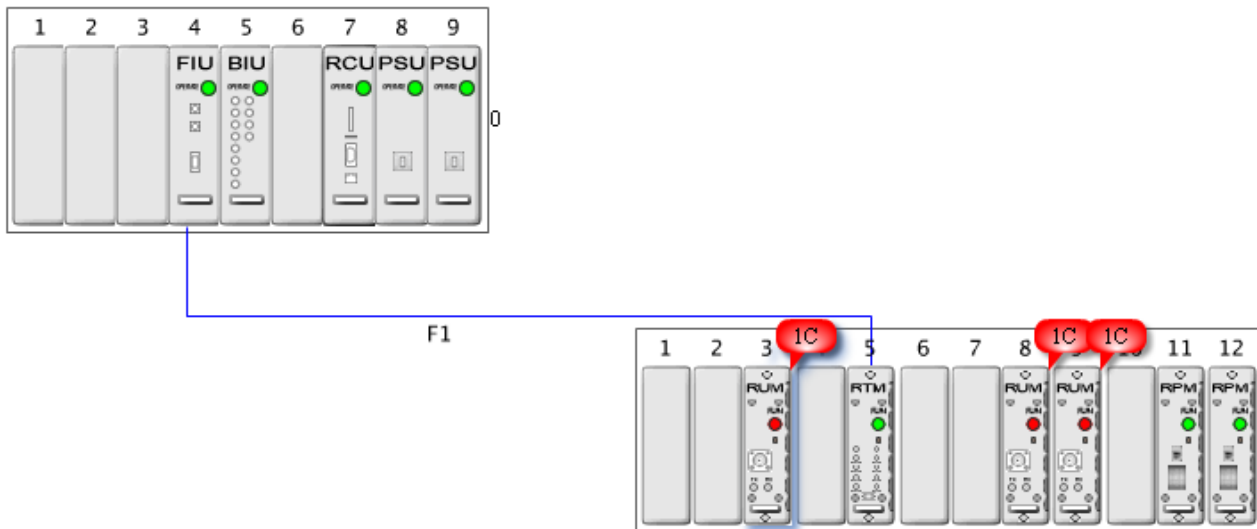

Figure 41- Main Page Equipment Status

Check the current status of each component as follows:

1. Update Topology view:
 - a. Click Re-Discover: If new equipment (eg. Remote Node) has been added but does not yet show up in the topology view
 - b. Click Refresh: If all components appear and to ensure current status is reflected
2. Review HU status indicators:
 - a. All OK: Component LEDs in the HU shelf indicate green state
 - b. Error/alarm: Component LEDs are flashing red, and a red “balloon” is present
3. Review Remote Node status indicators:
 - a. All OK: Component LEDs in the Remote Node indicate green state
 - b. Error/alarm: Component LEDs are flashing red, and a red “balloon” is present

If components appear with error conditions please see sections 5.3.3.1 Optical Link Alarms and 5.5 **Monitoring** for details on error conditions.

5.3.2.2 Verify Optical Power Levels

The optical power levels at both ends of the fiber link (at the FIU of the Host Unit, and the CM of the Remote Node) can be observed and verified through the EMS Local GUI.

Check optical power levels at the Host Unit as follows:

1. Click on the FIU in the topology diagram and the component window will pop up on the right as

shown in Figure 42- FIU Optical Power Levels.

2. Optical Transceiver 1 Tx Power: the output power of the FIU 1 to the fiber.
 - a. Nominal value is: +4.0 dBm +/-1.5 dB (impacted by temperature)
3. Optical Transceiver 1 Rx Power: the input power of the FIU 1 from the fiber.
 - a. Acceptable range is: -15 dBm ~ +6dBm (impacted by fiber loss)
4. Optical Transceiver 2Tx Power: the output power of the FIU 2 to the fiber.
 - a. Nominal value is: +4.0 dBm +/-1.5 dB (impacted by temperature)
5. Optical Transceiver 2 Rx Power: the input power of the FIU 2 from the fiber.
 - a. Acceptable range is: -15 dBm ~ +6dBm (impacted by fiber loss)

FIU(11)		General
System		
Model No.	mBSC-c-fiu	
Serial No.	12142204810113010002	
Software Version	V3.0.1.9_1304021907	
Equipment No.	11	
Optical Transceiver		
Optical Transceiver 1 Tx Power	4.3	
Optical Transceiver 1 Rx Power	1.2	
Optical Transceiver 2 Tx Power	4	
Optical Transceiver 2 Rx Power	-24	
Uplink Output Power 1	-40	dBm
Uplink Output Power 2	-40	dBm
Optical Transceiver 1 Alarm Enabled	<input checked="" type="checkbox"/>	
Optical Transceiver 2 Alarm Enabled	<input type="checkbox"/>	
Refresh finished.		
		<input type="button" value="Refresh"/> <input type="button" value="Save"/>

Figure 42- FIU Optical Power Levels

Check optical power levels at the Remote Node as follows:

- 1. Click on the RTM in the topology diagram and the component window will pop up on the right as shown in Figure 43- RTM Optical Power Levels.
- 2. Optical Transceiver 1 Tx Power: the output power of the RTM 1 to the fiber.
 - a. Nominal value is: +4.0 dBm +/-1.5 dB (impacted by temperature)
- 3. Optical Transceiver 1 Rx Power: the input power of the RTM from the fiber.
 - a. Acceptable range is: -15 dBm ~ +6dBm (impacted by fiber loss)

RTM_S4F1		General	Advanced	Super
System				
Unit Name	RTM_S4F1			
Model No.	mBSC1430-RTM-5SW			
Serial No.	10143000010114111002			
Software Version	V3.3.1.1_141127			
PTU Version	V1.1.0.9_20141103			
Unit No.	23			
System Temperature	31 °C			
Optical Transceiver				
Optical Transceiver Tx Power	4 dBm			
Optical Transceiver Rx Power	3.7 dBm			
Optical Transceiver Tx Alarm Enabled	<input checked="" type="checkbox"/>			
Optical Transceiver Rx Alarm Enabled	<input checked="" type="checkbox"/>			

Figure 43- RTM Optical Power Levels

5.3.2.3 Verify Software Versions

Click on **Help** in the upper right corner to verify the software version of the EMS Local GUI.

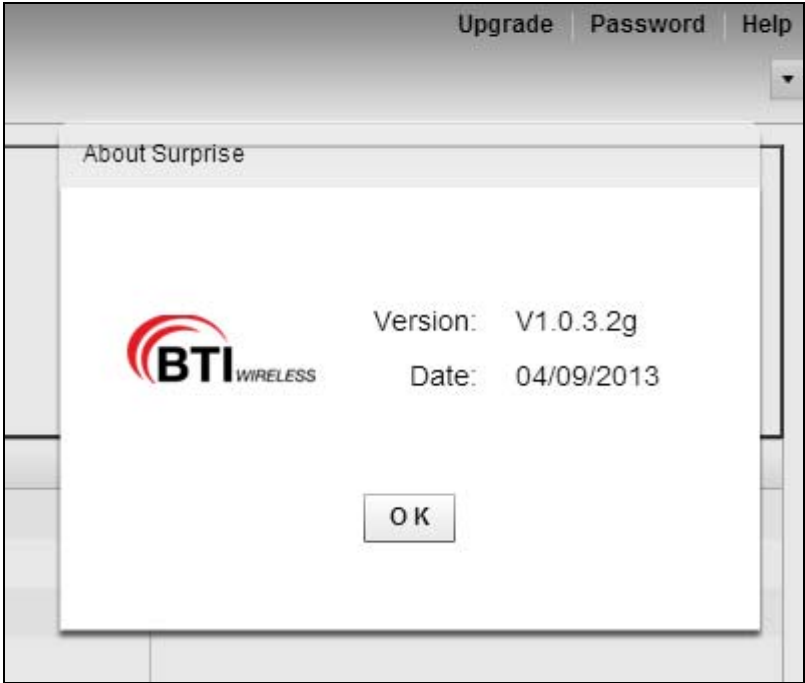

Figure 44 - EMS Local GUI Software Version

To verify the software version installed on each component click on the **Upgrade** button in the top right:

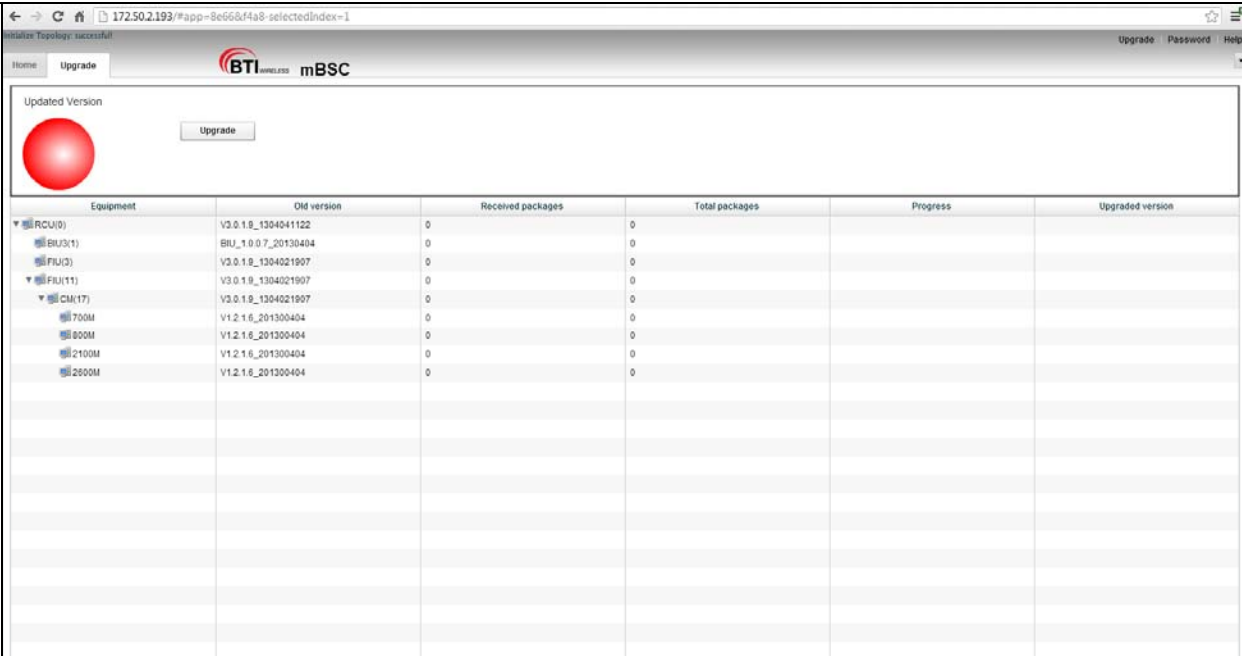

Figure 45 - Component Software Versions

5.3.3 Alarms

5.3.3.1 Optical Link Alarms

Optical Link alarms at the FIU will occur for various reasons:

1. Remote Node not in service: The Remote Node connected to the specific FIU link is not yet powered up
2. Remote Node malfunctioning: connected to the specific FIU link is in an error state
3. Fiber issue: The fiber link between the specific FIU and the Remote Node has excessive loss (possibly due to breakage or to dirty optical connectors)
4. No Remote Node: there is no plan to connect a Remote Node to the FIU (an FIU card supports two links and one link is not used in this system).

In Figure 38- Main Page Expanded Topology the FIU in slot 3 is indicating an alarm state. Note the following in Figure 46 – Optical Link Alarms:

1. The LED indicator for the FIU in slot 3 is not solid Green
 - a. A flashing red state indicates an alarm
2. There is a red “balloon” extending from the FIU in slot 3
 - a. The FIU supports two fiber connections: 1C indicates 1 alarm condition exists, 2C indicates 2 alarm conditions exist
3. There are no remote Nodes connected to the FIU in slot 3, and no fiber are extending from the FIU
 - a. In this case the HU recognizes there are no Remote Nodes connected
4. The FIU in Slot 6 is showing green operational status
 - a. No alarms are being reported, yet there is only one fiber extending from the FIU in connection F1
 - b. Normally this FIU would report an alarm state for F2 (“1C” showing in the red alarm balloon)
 - c. No alarm state is shown because the user disabled Optical Transceiver 2 Alarms

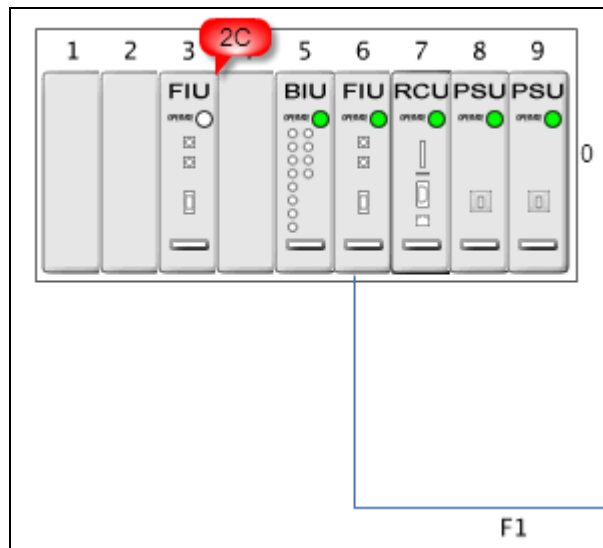

Figure 46 – Optical Link Alarms

To disable optical transceiver alarms:

1. Click on the desired FIU in the topology window. The FIU component dialog box will appear as in Figure 42- FIU Optical Power Levels
2. Optical transceiver 1 Alarm Enabled:
 - a. To enable alarms place a “check” in the box
 - b. To disable alarms clear the box
3. Optical transceiver 2 Alarm Enabled:
 - a. To enable alarms place a “check” in the box
 - b. To disable alarms clear the box
4. Click **Save**

5.3.3.2 Enable SNMP alarms

Support for SNMP in the mBSC-C system is provided through the remote EMS Server. For more information about support for SNMP please refer to UM-MBSC-C-EMS.

5.4 System Tuning

5.4.1 BTS Signal Conditioning

The interface from the operator BTS equipment to the MBSC2500-005-RUCM11 is via simplex RF connections to the BIU. The nominal downlink input to the BIU (TXin) is 0 dBm±1dB (range: -10dBm to +10dBm). If the BTS signal downlink exceeds +10 dBm, or the signal is a composite duplex RF signal, then RF signal conditioning will be required.

BTI provides a high-power Point of Interface to perform RF signal conditioning (mBSC-C-POI) The use and operation of this component is outside the scope of this document.

5.4.2 Set Downlink Gain

It may be necessary to adjust the Downlink gain of the mBSC-C system in order to achieve a balanced forward and reverse link, or to adjust for other conditions (input levels from the BTS, propagation characteristics at different bands, specific RF design). The MBSC2500-005-RUCM11 provides two points of adjustment for downlink gain:

1. Software controlled attenuator for each band in the BIU
2. Software controlled attenuator in each band-specific Remote Unit

The determination of appropriate values for these parameters is outside the scope of this document.

5.4.2.1 Adjust BIU Downlink Attenuator

Adjust the BIU downlink value for each frequency band as follows:

1. Click on the BIU in the topology diagram and the component window will pop up on the right as shown in Figure 47 - BIU Attenuator.
2. Downlink Attenuation Value (XXX MHz): Input the appropriate value for each frequency band (0dB – 25dB range)
3. Click **Save**

Note that the system will report an error message if the input value is out of range.

BIU3(1) General

basic

Model No. bti-mbsc-c-biu-001
Serial No. 12142204510113010001
Software Version BIU_1.0.0.7_20130404
Equipment No. 1

Uplink

Attenuation Value(700M)	30	▲▼	
Attenuation Value(800M)	2	▲▼	dB(0dB~25dB)
Attenuation Value(1900M)	3	▲▼	dB(0dB~25dB)
Attenuation Value(2100M)	4	▲▼	dB(0dB~25dB)
Attenuation Value(2600M)	5	▲▼	dB(0dB~25dB)

Downlink

Attenuation Value(700M)	6	▲▼	dB(0dB~25dB)
Attenuation Value(800M)	7	▲▼	dB(0dB~25dB)
Attenuation Value(1900M)	8	▲▼	dB(0dB~25dB)
Attenuation Value(2100M)	7	▲▼	dB(0dB~25dB)
Attenuation Value(2600M)	10	▲▼	dB(0dB~25dB)

The value entered is out of range, please enter a value within the specified range!

Refresh finished. Refresh Save

Figure 47 - BIU Attenuator

5.4.2.2 Adjust RU Downlink Attenuator

Adjust the RU downlink value for the specific RU / frequency band as follows:

1. Click on the RU in the topology diagram and the component window will pop up on the right as shown in Figure 48 - RU Attenuator.
2. Downlink Attenuation Value: Input the appropriate values (0dB – 6dB range)
3. Click **Save**

RUM_2500MHz_S4F1		General	Advanced	PA Module	Super
System					
Unit Name	RUM_2500MHz_				
Model No.	MBSC2500U-005-RUCM11				
Serial No.	MBSC250000520150203				
Software Version	V2.0.3.7_20150108				
Unit No.	2				
DL VSWR	1.2				
DL Output Power	NA dBm				
PA Temperature	27 °C				
DL PA Run Status	Normal				
DL PA Voltage Value	28.8 V				
UL Input Power	-87 dBm				
Setting					
UL Attenuation Value	3	▼	dB(0~6)		
DL Attenuation Value	3	▼	dB(0~6)		
See the configuration guide for standard values.					
UL Max Attenuation	OFF	▼			
PA Reset	PA Reset				
DL PA Disable	OFF	▼			
DL Output Under Power Alarm Enabled	<input checked="" type="checkbox"/>				
DL Output Under Power Threshold	22		dBm		
Diagnostic Tools					
UL Pilot Frequency	2630		MHz(900-964)		
Refresh finished.					
			Refresh	Save	

Figure 48 - RU Attenuator

5.4.3 Set Uplink Gain

It may be necessary to adjust the Uplink gain of the mBSC-C system in order to achieve a balanced forward and reverse link, or to adjust for other conditions (antenna placement, dynamic range requirements, propagation characteristics at different bands, specific RF design). The MBSC2500-005-RUCM11 provides two points of adjustment for uplink gain:

- 1. Software controlled attenuator for each band in the BIU
- 2. Software controlled attenuator in each band-specific Remote Unit

The determination of appropriate values for these parameters is outside the scope of this document.

5.4.3.1 Adjust BIU Uplink Attenuator

Adjust the BIU uplink attenuation value for each frequency band as follows:

1. Click on the BIU in the topology diagram and the component window will pop up on the right as shown in Figure 47 - BIU Attenuator.
2. Uplink Attenuation Value (XXX MHz): Input the appropriate value for each frequency band (0dB – 25dB range)
3. Click **Save**

5.4.3.2 Adjust RU Uplink Attenuator

Adjust the RU uplink attenuation value for the specific RU / frequency band as follows:

1. Click on the RU in the topology diagram and the component window will pop up on the right as shown in Figure 48 - RU Attenuator.
2. Uplink Attenuation Value: Input the appropriate values (0dB – 6dB range)
3. Click **Save**

5.4.4 Link Verification

The MBSC2500-005-RUCM11 system is equipped with features that enable the downlink and uplink link to be fine-tuned from the head-end location using common test equipment (RF signal generator and RF power detector).

5.4.4.1 Verify End-to-End Downlink Gain

Each RU in the remote node is equipped with a calibrated Downlink Power Detector which will display the average power at the output of the RU. By injecting an RF CW signal at each TXin port of the BIU the end-to-end downlink system gain can be verified without additional test equipment required at the Remote Node.

Verify the end-to-end Downlink Gain for each frequency band as follows:

1. Using an RF Signal generator inject a CW RF signal to the TXin port of the BIU
 - a. Set the frequency to the center of the spectrum to be used in the system (if the operator licensed bands are not known set the frequency to center of the band – e.g. 2550 MHz for TDD-LTE band)
 - b. Set the input RF power level to be 3 – 5 dB below the expected RF level to product maximum output power at the RU to avoid accidental overdrive (e.g. if the gain is set so that 0dBm input will produce +37 dBm at the output then start with -5dBm)
2. The resultant Downlink output power of the RU can be observed in two ways:
 - a. In the topology window the Downlink Output power is displayed next to the specific RU (e.g. 30.7 dBm indicated in the topology diagram by the 800MHz RU in Figure 49 – Up/Down Link Verification)
 - b. Downlink Output Power: In the component window
3. Variations in filtering, amplifiers, and optical loss may cause the actual system gain to vary +/- 6 dB. All paths can be normalized by adjusting downlink attenuation settings in the BIU.
4. This procedure should be repeated for each frequency band in the system

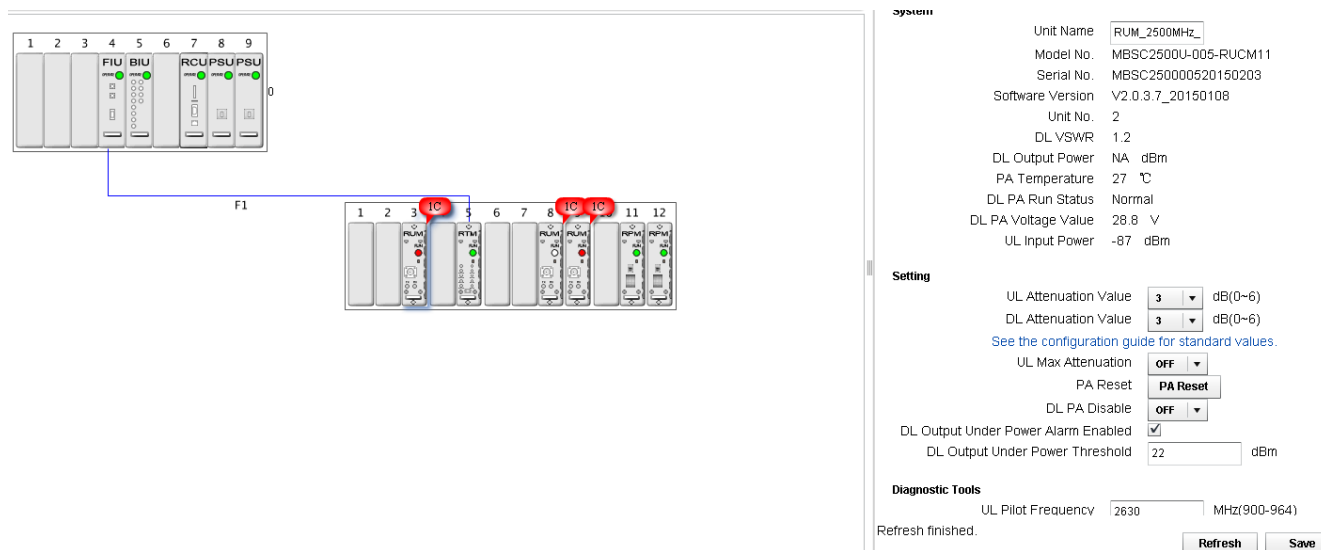

Figure 49 – Up/Down Link Verification

5.4.4.2 Using Uplink Pilot Tone Generator

Each RU in the remote node is equipped with an Uplink Pilot Tone Generator which will generate a CW RF tone out of the RU back towards the FIU and BIU.. By measuring the RF power at the RXout port of the BIU the end-to-end uplink system gain can be verified, and band-to-band / node-to-node, variations calibrated without additional test equipment required at the Remote Node.

Verify the end-to-end Uplink Gain for each frequency band as follows:

1. Click on the RU for the desired frequency band. The component window ;will pop up as shown in Figure 49 – Up/Down Link Verification
 - a. Uplink Pilot Frequency: Set the frequency to the center of the spectrum to be used in the system (if the operator licensed bands are not known set the frequency to center of the band)
 - b. Uplink Pilot Frequency Switch: select ON from the drop-down box
 - c. Click **Save** to turn the Uplink Pilot generator ON
2. Connect an RF power meter to the corresponding RXout port of the BIU
 - a. A -6 dBm value in the Uplink Pilot Frequency Output Power field of the RU corresponds to an equivalent signal of -60 dBm at the input to the RU
 - b. Variations in filtering, amplifiers, and optical loss may cause the actual system gain to vary +/- 6 dB. All paths can be normalized by adjusting uplink attenuation settings in the BIU.
3. This procedure should be repeated for each frequency band in the system

Note: Uplink Pilot Frequency Switch should be off during normal operations. This function is intended for testing, verifying, and adjusting uplink performance and will interfere with normal operation of the system.

5.5 Monitoring and Alarms

5.5.1 Operational Status

5.5.1.1 Host Unit

The EMS Local GUI graphical interface will notify users of an error or malfunction in the Host Unit with a red popup “alarm indicator”. The alarms will also be displayed in the lower section of the component window.

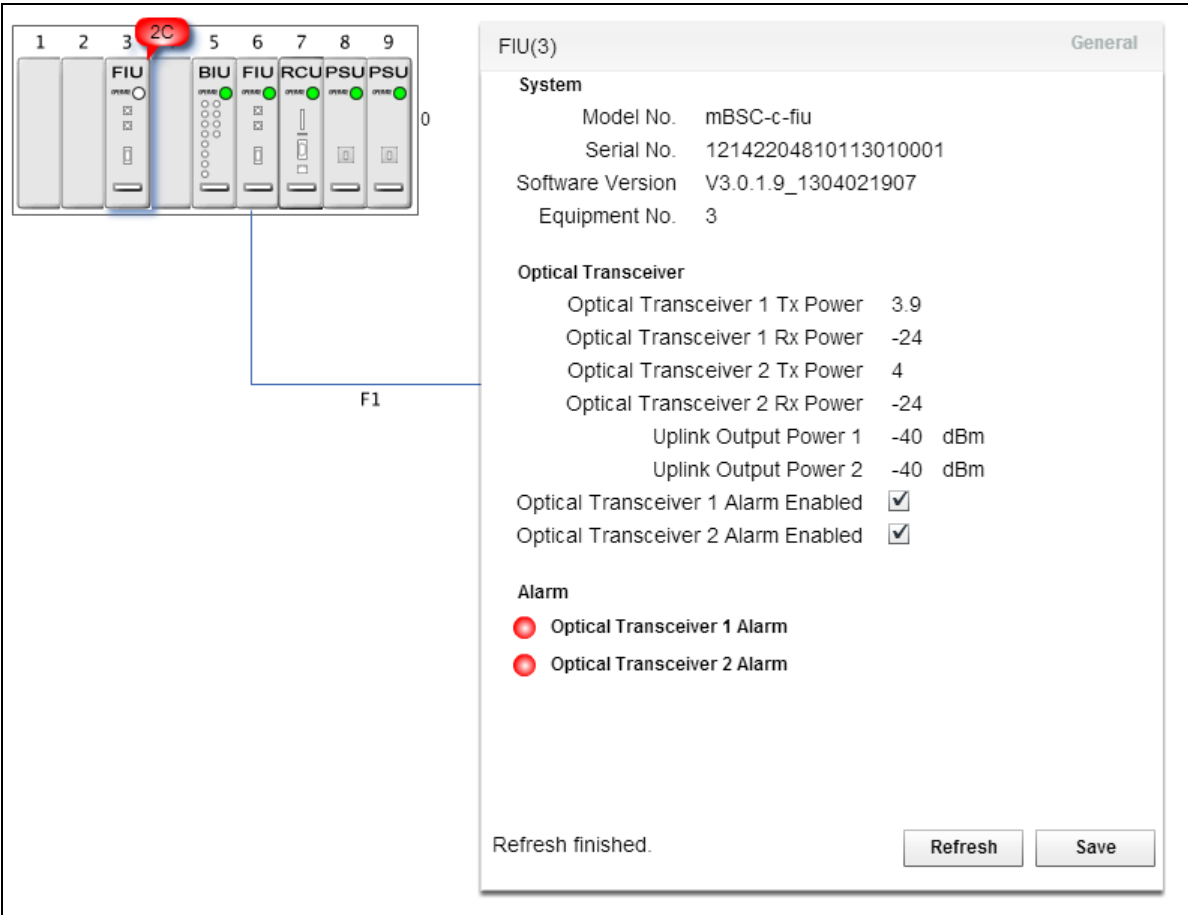

Figure 50 - Host Unit Alarm Status

5.5.1.2 Remote Node

In the case of a Remote Node malfunction, the affected unit will also be marked with a red popup “alarm indicator”. Figure 51 - Remote Node Alarm Status illustrates a condition where both fans of an RU are not working (power cable disconnected):

1. The alarm indicator beside the affected RU in the topology view displays “2C”
2. Additional alarm status is shown in the lower right section of the RU component window.

UL Attenuation value **3** dB(0~6)
 See the configuration guide for standard values.
 UL Max Attenuation **OFF**
 PA Reset **PA Reset**
 DL PA Disable **OFF**
 DL Output Under Power Alarm Enabled
 DL Output Under Power Threshold **22** dBm

Diagnostic Tools
 UL Pilot Frequency **2630** MHz(900-964)
 UL Pilot Switch Enable **OFF**
 Pilot Signal simulates a -60 dBm signal as an input to the Remote Unit.

Alarm
 ● **DL Output No Power Alarm**

Figure 51 - Remote Node Alarm Status

5.5.2 System Alarms

The MBSC2500-005-RUCM11 provides alarm indications for equipment malfunctions or for conditions that place the out of standard operating range (such as over-power). A complete list of alarm events, and the originating product module, is provided in Table 16System Alarms.

These events are enabled by default factory settings, but can be disabled if desired.

These alarm events can be observed in multiples ways:

- In the EMS Local GUI in the network topology view and corresponding component parameter windows
- In the Monitor window of the remote EMS Server
- As SNMP traps issued by the remote EMS Server (if enabled)

Table 16System Alarms

Item	Equipment	Module	Alarm ID	Alarm Name	Description
1	Host Unit	RCU	401500	Host/Remote Link	Optical RX signal is detected by the FIU but no logical connection exists to the Remote Node (CM)
2			423000	System Temperature	A system over-temperature alarm has been reported
3	Host Unit	FIU	401500	Host/Remote Link	Optical RX signal is detected by the FIU but no logical connection exists to the Remote Node (CM)
4			422000	Optical Transceiver 1	Low/No optical signal is detected on Link 1
5			422100	Optical Transceiver 2	Low/No optical signal is detected on Link 2
6	Remote Node	RTM	401500	Host/Remote Link	Optical RX signal is detected by the CM but no logical connection exists to the Host Unit (FIU)
7			423000	System Temperature	A system over-temperature alarm has been reported
			408301	Fan 1 Alarm	Fan 1 is non-functioning (low current)
			408302	Fan 2 Alarm	Fan 2 is non-functioning (low current)
8			400100	Power Down	Power has been lost at the Remote Node (internal battery backup enables alarm delivery)
9			401920	PA Over VSWR	High VSWR detected at output of PA
10			427000	PA Over Output Power	PA output power exceed threshold

11	Remote Node	RU	PA	401620	PA Fault Alarm	PA overdrive condition exists
12				400600	PA Over Temperature Alarm	High temperature condition in final PA stage
13				427100	PA Lower Gain Alarm	Low gain condition (< 10dB) detected
14			SSM	401000	Uplink LNA Fault Alarm	Internal LNA fault detected

5.6 System Upgrade

To conduct a system upgrade, navigate to the upper right section and click on “**Upgrade**”.

5.6.1 Verify Software Versions

Verify component versions in the second column of the **Upgrade** tab.

5.6.2 Upgrade component software

Click on the “**Upgrade**” button and locate the firmware file to start the component upgrade. *Note: Each component upgrade time differs from one another ranging from 5 minutes to 120 minutes.*

Equipment	Old version	Received packages	Total packages	Transfer progress	Upgraded version
RCU	V3.3.2.10_150126	0	0		
BIUWD_S5	V1.1.0.8_20140918	0	0		
FIUWD_S4	V3.3.2.9_150121	0	0		
RTM_S4F1	V3.3.1.1_141127	0	0		

Figure 52 - Component Upgrade

6 Maintenance

Note: Check your sales order and equipment warranty before attempting to service or repair the mBSC-C system. Breaking the seals on equipment under warranty will void the warranty. Do not return equipment for warranty or repair until proper shipping instructions are received from the factory.

6.1 Electrostatic Discharge Precautions

The mBSC-C system modules contain assemblies and components which are sensitive to electrostatic discharge (ESD). Carefully observe the precautions and recommended procedures to verify that system reliability is not compromised due to component damage from static electricity.

The following precautions will significantly reduce the risk of system failure or malfunction due to ESD:

1. Always wear a grounded wrist strap while working around the system
2. Consider all assemblies, components and connections to be ESD sensitive
3. When unpacking circuit boards, interfaces and modules that are packaged separately from the system, keep them in their conductive wrapping until they are ready to be installed.
4. Before removing or replacing any components, select a work area where potential static sources are minimized
5. Handle circuit packs and boards by the grounded housings, avoiding contact with the connectors

6.2 Preventative Maintenance

The mBSC-C system requires minimal regular maintenance to ensure continuous and satisfactory operation. Maintenance includes diagnosing and correcting the service problems as they occur. When an alarm is reported, it is necessary to follow a troubleshooting procedure to identify the source of the problem.

The following are recommended routine maintenance procedures:

- Check the indicator status LEDs (normal or alarm).
- Prevent dust or grime from accumulating on the surface of heat sinks.
- Check power output.

6.3 Fault Detection and Alarm Reporting

The mBSC-C on-board embedded firmware detects unit and system faults and reports them as system alarms. The following methods may be used to report alarms:

- Dry-contact alarm points
- Status LEDs on system components
- NMS (Local GUI, remote NMS, and SNMP Alarms)

The mBSC-C Host Unit components are equipped with multiple LED indicators that show status and alarms by displaying Green, Red or Off. Detailed descriptions of the LED indicators are provided respectively in section 3.2.7 Host Unit Interface.

The NMS software provides detailed alarm information which includes module level faults, circuit faults and measured value faults such as door, RF power and temperature.

6.4 Troubleshooting Quick Guide

Use this section to quickly troubleshoot alarms and faults.

Table 17 Troubleshooting Quick Guide

Problem	Quick Troubleshooting Steps / Possible Cause
No RF output	<ol style="list-style-type: none"> 1) Optical path is faulty; 2) Downlink path BTS input signal is low/not present 3) Remote Node RU is faulty.
RF output power level is low	Measure the downlink output power at the output of the RU, and at the input to the antenna <ol style="list-style-type: none"> 1) Passive components between the RU and the antenna port are faulty; 2) Host Unit RF input connections are faulty; 3) Optical path is faulty; 4) RU is faulty.
Loss of phone service, but the RF signal level is normal	<ol style="list-style-type: none"> 1) Test calling in the coverage area of original BTS. It may be the BTS problem if the situation is the same; 2) Measure the gain both of the forward path and reserve path to see whether they are close; 3) RU LNA module is faulty.
Power supply is out of service	<ol style="list-style-type: none"> 1) Measure the DC power input source. If the voltage is out of 48VDC +/- 20%, add a regulated power supply between the power in connector and the power source. 2) The interior power unit is faulty.

6.4.1 Host Unit Trouble Shooting

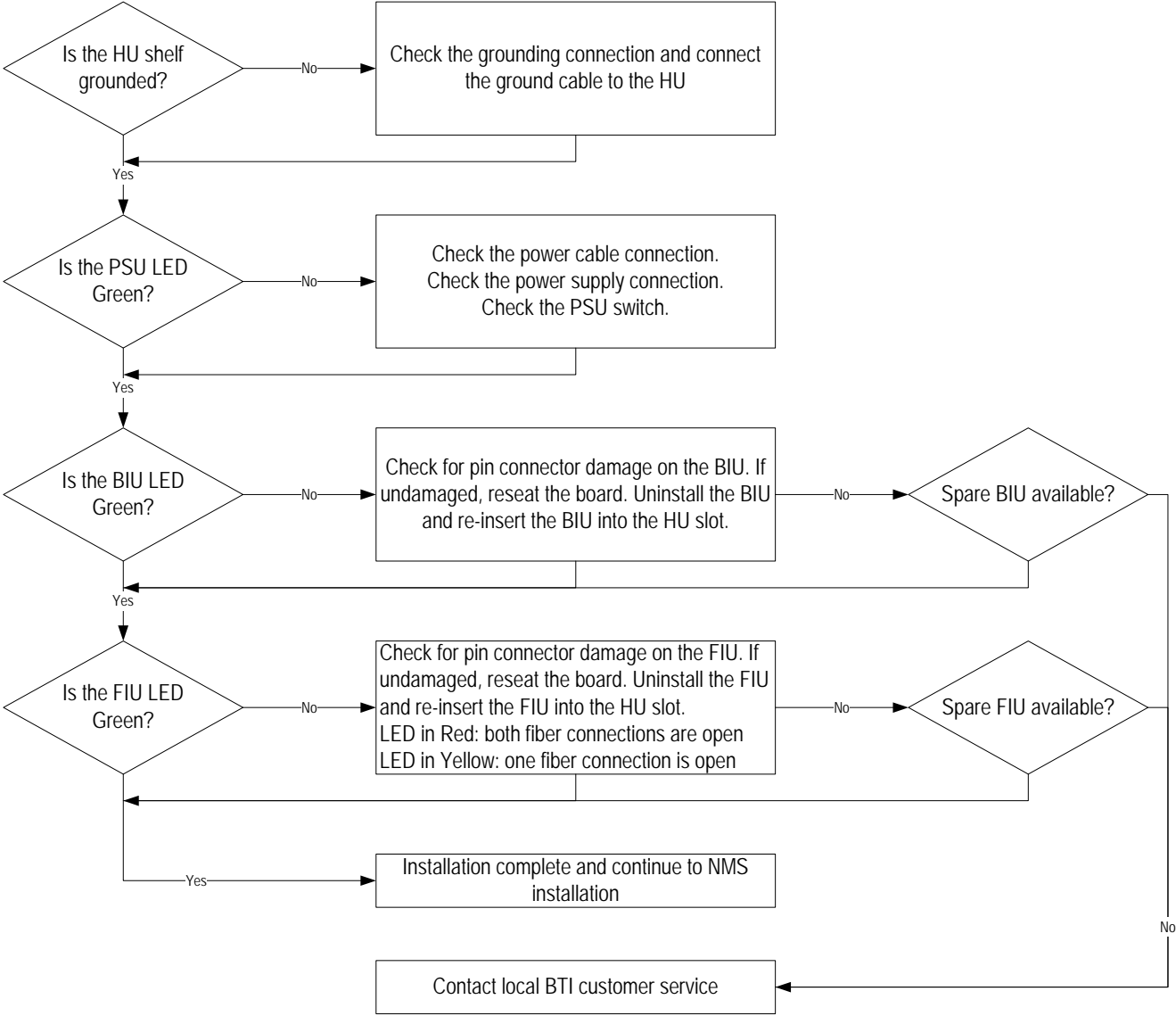

Figure 53 Host Unit Trouble Shooting

6.4.2 Remote Unit Trouble Shooting

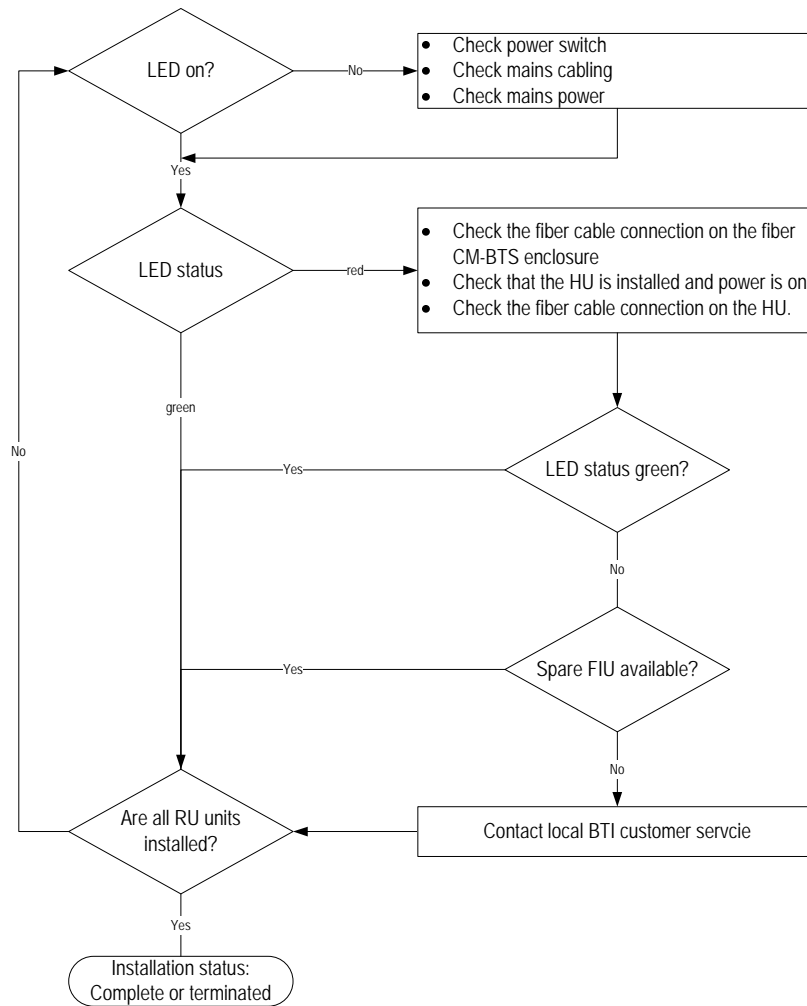

Figure 54 Remote Unit Trouble Shooting

7 Terms, Acronyms & Abbreviations

Table 18 Terms, Acronyms and Abbreviations

Terms/Acronyms/Abbreviation	Definition
ANT	Antenna
AWG	American Wire Gauge
BTS	Base Transceiver Station or Base Transceiver System
C°	Degree Celsius
COM	Serial Communication Port
CQT	Call Quality Test
dB	Decibels
dBm	Power measurement referenced to the specific power level of one milli watt
DCS	Digital Cellular System
DIN	Deutsches Insitut für Normung eV (German standardsinstitution)
7-16 DIN	German standards RF connector: 7mm OD of inner contact, 16mm ID of outer contact.
DL	Downlink
DT	Driver Test
EMC	Electromagnetic Compatibility
GSM	Global System for Mobile Communications
LED	Light Emitting Diode
LNA	Low Noise Amplifier
NMS	Network & Monitoring System
MCPA	Multi-carrier Power Amplifier
MHz	Megahertz
MTBF	Mean Time Between Failures
OMC	Operation Monitor Center
PA	Power Amplifier
RF	Radio Frequency
RX	Receive or Receiver
SMA	Subminiature Type A coaxial connector
TX	Transmit, Transmitter
UMTS	Universal Mobile Telecommunications System
VSWR	Voltage Standing Wave Ratio

2500MHz	Downlink	2496MHz~2616MHz
	Uplink	2496MHz~2616MHz
Maximum Output Power	Downlink	37.75dBm
	Uplink	4.96dBm
Max Gain	Downlink	54±0.5dB
	Uplink	62±0.5dB
Antenna Type	Downlink	External antenna (N female)
Antenna Gain	Downlink	17dBi
Type of modulation and Designator		LTE(W7D)
Remark		The EUT does not transmit over the air in the uplink direction.

8 Packing List

List	brand	quantity
mBSC2500L-005-RUCM11	BTI Wireless	1
mBSC1430-RTM-5SW	BTI Wireless	1
mBSC1426-RPM-AC	BTI Wireless	2
Fiber-cable(E2000-E2000)	/	1
RF-Cable(QMA-QMA)	/	2
Power cable	/	1
mBSC1426-RACK-10S	BTI Wireless	1

To submit your comments by mail, use the response card behind the front cover of your document, or write to the following address:

Attn: Publications Manager

BTI Wireless

6185 Phyllis Drive

Cypress, CA 90630

We appreciate your comments.

For US and Canadian installations: FCC RF exposure compliance requires the following antenna installation and device operation configurations be satisfied:

A separation distance of at least 6 meters must be maintained between the antenna of this device and all persons. RF exposure compliance may need to be addressed at the time of licensing, as required by the responsible FCC Bureau(s), including antenna co-location requirements of 1.1307(b)(3). § 2.1091

Maximum permissible antenna gain is 17 dBi.

IC STATEMENT Operation is subject to the following two conditions:

- (1) This device may not cause interference, and
- (2) This device must accept any interference, including interference that may cause undesired operation of the device.

Le présent appareil est conforme aux CNR d'Industrie Canada applicables aux appareils radio exempts de licence.

L'exploitation est autorisée aux deux conditions suivantes :

- (1) l'appareil ne doit pas produire de brouillage, et
- (2) l'utilisateur de l'appareil doit accepter tout brouillage radioélectrique subi, même si le brouillage est susceptible d'en compromettre le fonctionnement.

IC Radiation Exposure Statement

This equipment complies with IC radiation exposure limits set forth for an uncontrolled environment. This equipment should be installed and operated with minimum distances 6 m between the radiator include antenna & your body.

IC Déclaration sur la radio exposition

Cet équipement est conforme avec l'exposition aux radiations IC définies pour un environnement non contrôlé . Cet équipement doit être installé et utilisé avec une distance minimale de 6 m de entre le radiateur inclure l'antenne et votre corps.

The Manufacturer's rated output power of this equipment is for single carrier operation. For situations when multiple carrier signals are present, the rating would have to be reduced by 3.5 dB, especially where the output signal is re-radiated and can cause interference to adjacent band users. This power reduction is to be by means of input power or gain reduction and not by an attenuator at the output of the device

FCC Statement

This device complies with part 15 of the FCC Rules. Operation is subject to the following two conditions: (1) this device may not cause harmful interference, and (2) this device must accept any interference received, including interference that may cause undesired operation.

This equipment has been tested and found to comply with the limits for a Class B digital device, pursuant to Part 15 of the FCC Rules. These limits are designed to provide reasonable protection against harmful interference in a residential installation. This equipment generates, uses and can radiate radio frequency energy and, if not installed and used in accordance with the instructions, may cause harmful interference to radio communications. However, there is no guarantee that interference will not occur in a particular installation. If this equipment does cause harmful interference to radio or television reception, which can be determined by turning the equipment off and on, the user is encouraged to try to correct the interference by one or more of the following measures:

- Reorient or relocate the receiving antenna.
- Increase the separation between the equipment and receiver.
- Connect the equipment into an outlet on a circuit different from that to which the receiver is connected.
- Consult the dealer or an experienced radio/TV technician for help.

Changes or modifications not expressly approved by the party responsible for compliance could void your authority to operate the equipment.