

# User Manual

11n/a & 11n/g/b Concurrent Smart model

## WAPS-APG600H

11n/a, 11n/g/b Single Smart model

## WAPS-AG300H



# Contents

## **Chapter 1 - Product Overview ..... 3**

---

Package Contents.....	3
Hardware Overview .....	4
Front Panel LEDs.....	4
Back Panel.....	6

## **Chapter 2 - Placing Your AirStation ..... 8**

---

Antenna Placement.....	8
Installation.....	8
Connecting Power Sourcing Equipment (Sold Separately) .....	8
Connecting the AC Adapter (Sold Separately).....	10
Initial Setup .....	11
Installing the AirStation Configuration Tool .....	11
Setting the AirStation IP Address .....	12
Accessing the Web-based Configuration Interface.....	14
Enabling the Wireless LAN Functions and Making the Encryption Settings.....	16
Setting the Password in the Configuration Interface.....	18
Mounting to a Ceiling or Wall .....	20
Mounting the Security Case (Sold Separately).....	22
Removing the AirStation .....	24

## **Chapter 3 - Connect to a Wireless Network ..... 25**

---

Automatic Secure Setup (AOSS/WPS).....	25
Windows 7/Vista (Client Manager V) .....	26
Windows XP (Client Manager 3).....	27
Mac OS X (AOSS Assistant).....	28

Manual Setup .....	29
Windows 7 (WLAN AutoConfig) .....	29
Windows Vista (WLAN AutoConfig) .....	30
Windows XP (Wireless Zero Configuration).....	33
Mac OS X (Wi-Fi).....	34
<b>Chapter 4 - Checking Wireless Signal Quality .....</b>	<b>35</b>
<b>Chapter 5 - Default Configuration Settings .....</b>	<b>38</b>
<b>Appendix A - Specifications .....</b>	<b>43</b>
<b>Appendix B - TCP/IP Settings.....</b>	<b>45</b>
Windows 7 .....	45
Windows Vista.....	46
Windows XP .....	47
Mac OS X.....	48
<b>Appendix C - Restoring the Default Configuration .....</b>	<b>49</b>
<b>Appendix D - Regulatory Compliance Information .....</b>	<b>50</b>
<b>Appendix E - Environmental Information.....</b>	<b>56</b>
<b>Appendix F - GPL Information.....</b>	<b>57</b>

# Chapter 1 - Product Overview

## Package Contents

---

The following items are included in your AirStation package. If any of the items are missing, please contact your vender.

- Wireless LAN access point..... 1
- Antennas (Dual band 2.4 GHz / 5 GHz) ..... 2
- Antenna cap (already attached to antenna) ..... 2
- Wall-mounting fixture ..... 1
- Ceiling-mounting wooden screws (large)..... 4
- Wall-mounting wooden screws (medium) ..... 4
- Wall-mounting anchor (for medium-size wooden screws)..... 4
- Screws (Small: Length 5 mm \*)..... 2
- Screws (Small: Length 4 mm \*)..... 4
- Spacers (Ring-shaped metal part)..... 2
- Ejector (L-shaped part)..... 1
- AirNavigator CD..... 1
- Serial number sticker..... 2
- Quick Setup Guide..... 1
- Warranty Statement..... 1

\*  — The “length” here refers to the length of the section shown in the figure.

An AC adapter is not included with this AirStation unit, and so please order an AC adapter (WLE-OP-AC12, sold separately) or use separate PoE-enabled power sourcing equipment.

# Hardware Overview

---

## Front Panel LEDs

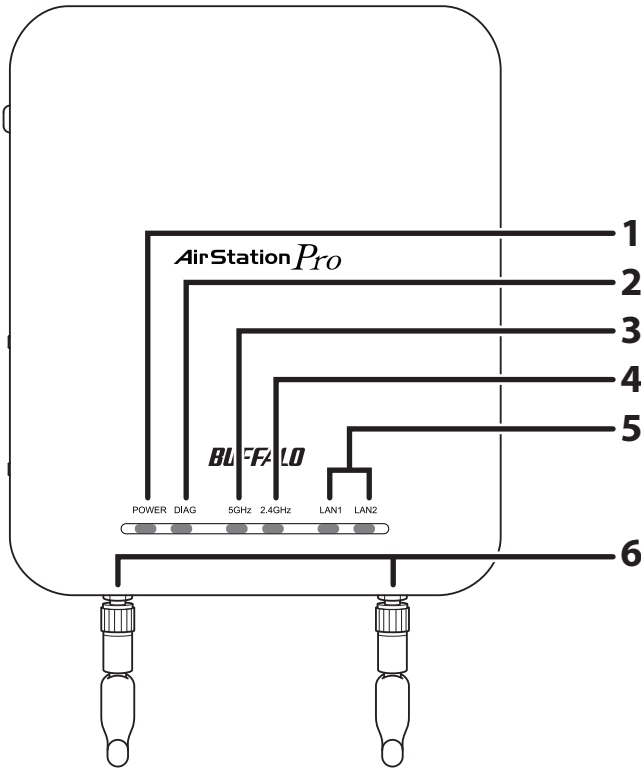

### 1 Power LED

On: Power is on.

Off: Power is off.

This LED is off when the "LED setting" is set to Off.

### 2 Diag LED (Red)

This indicates the status of this unit depending on the number of blinks per cycle.

Note: When the unit is first turned on or restarted, the Diag LED will blink for almost a minute during boot. This is normal.

Off: Normal.

Solid red at startup (about 2 to 3 minutes): RAM error.

Blinks red twice at startup or immediately after settings are saved: Flash ROM error.

3 blinks*2:	Wired Ethernet LAN error.
4 blinks*2:	Wireless LAN error.
5 blinks:	USB error.
9 blinks*2:	System error.
Continuously blinking*1:	Updating firmware, saving settings, or initializing settings.

\*1 Never unplug the AC adapter while the Diag LED is blinking continuously.

\*2 Turn off AirStation first, wait for a few seconds, then turn it back on.

### **3 5 GHz LED (Blue)**

On:	5 GHz wireless LAN is enabled.
Randomly blinking:	5 GHz wireless LAN is transmitting.
2 blinks:	AirStation is waiting for an AOSS or WPS security key.
Continuously blinking:	AOSS/WPS error; failed to exchange security keys.

Note: This LED is off when "LED Setting" is set to Off. The default setting is Off (Disable). Enable the wireless function by referring to "Enabling the Wireless LAN Functions and Making the Encryption Settings" (page16).

### **4 2.4 GHz LED (Green)**

On:	2.4 GHz wireless LAN is enabled.
Randomly blinking:	2.4 GHz wireless LAN is transmitting.
2 blinks:	AirStation is waiting for an AOSS or WPS security key.
Continuously blinking:	AOSS/WPS error; failed to exchange security keys.

Note: This LED is off when "LED Setting" is set to Off. The default setting is Off (Disable). Enable the wireless function by referring to "Enabling the Wireless LAN Functions and Making the Encryption Settings" (page16).

### **5 LAN LED (Green)**

On:	An Ethernet device is connected.
Blinking:	An Ethernet device is communicating.

### **6 Antenna Connector** Screw on the included antennas here.

Note: The supplied antenna supports both the 2.4 GHz and 5 GHz bands.

## Back Panel

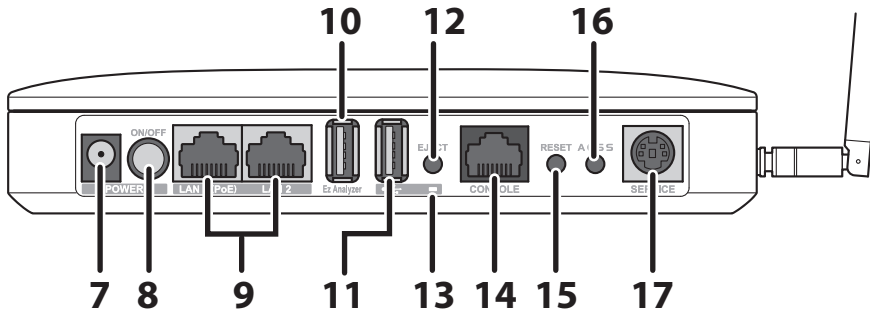

- 7 DC Connector**      The AC adapter (WLE-OP-AC12, sold separately) is connected here.
- 8 Power button**      This button turns the power on and off.
- 9 LAN Port**      The AirStation LAN port is connected to a computer, hub, or other network device using a LAN cable. Because the AirStation LAN port supports AUTO-MDIX, it can be connected to a network device regardless of the LAN cable type (straight or cross).  
LAN port 1 supports PoE devices. If PoE-enabled power sourcing equipment (sold separately) is connected, power can be received from the LAN cable so that an AC adapter does not need to be connected. For details on PoE, see the manual for your power sourcing equipment (sold separately).
- 10 Function expansion USB port**      This is a USB port for function expansion. It cannot be used with the current firmware version.
- 11 USB Port**      A USB memory device (sold separately) is connected here. When a USB memory device is connected, you can start the AirStation using a specific firmware version and save log information.
- 12 USB Eject Button**      Press this button when removing the USB memory device from the AirStation. Holding down the button for three seconds or longer will perform the disconnection process, which disables access from the AirStation to the USB memory device for enabling safe removal of the USB memory device.  
  
Be sure to always press this button and check that the USB LED is blinking before removing the USB memory device. If the USB memory device is removed while it is being accessed, the data could become corrupted, or the device could be damaged.

**13 USB LED (Green)**

On: USB memory device is being used.  
Randomly blinking: USB memory device can be removed.

**14 RJ-45 serial console port for settings** This is an RJ-45 serial console port for settings. This cannot be used in the current firmware version.

**15 Reset Button** To reset all settings, hold down this button until the Diag LED comes on (about 3 seconds). Power must be on.

**16 AOSS/WPS button** Pressing this button until the 5 GHz LED / 2.4 GHz LED flashes twice (about 1 second) will change to the AOSS or WPS connection standby status.

**17 Maintenance port** This cannot be used in the AirStation.



# Chapter 2 - Placing Your AirStation

## Antenna Placement

---

Remove the antenna cap, and attach the supplied antenna here. The antenna connector can be easily damaged, and so be careful not to touch it.

Note: The supplied antenna supports both the 2.4 GHz and 5 GHz bands.

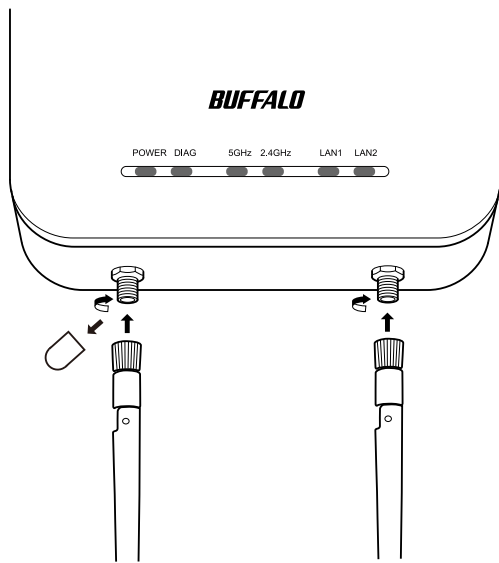

## Installation

---

### Connecting Power Sourcing Equipment (Sold Separately)

If PoE (Power over Ethernet) enabled power sourcing equipment (sold separately) is used to provide power to the AirStation, perform the procedure below to connect the power sourcing equipment.

- Notes:
- Power sourcing equipment can be connected to the LAN 1 port only. The LAN 2 port does not support PoE, and so do not connect power sourcing equipment to this port. Doing so could cause a breakdown of the device.
  - PoE is a function compliant with the IEEE802.3af or IEEE802.3at standards, and it enables data signal transmission and powering of devices over a single LAN cable. A device with a PoE function can be used without connecting a power cable by simply connecting it to an AirStation with a LAN cable.
  - If power is supplied using PoE, do not connect an AC adapter.
  - Some power sourcing equipment may be unable to supply power to the AirStation depending on its specifications. Be sure to always use power sourcing equipment that is compatible with the AirStation.

- 1** Use a LAN cable to connect the PoE port of the power sourcing equipment to the LAN 1 port of the AirStation.

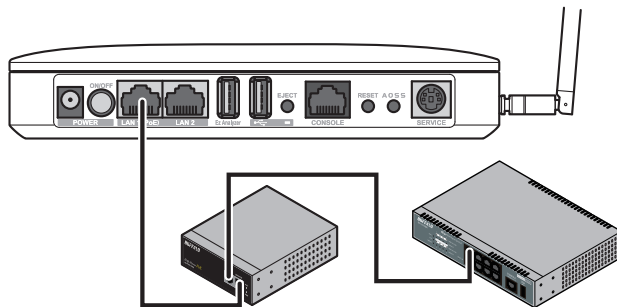
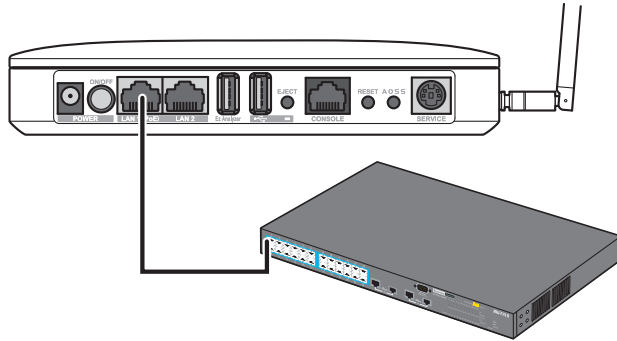

Note: Be sure that the cable connecting the AirStation and power sourcing equipment is an enhanced Category 5 or higher 4-pair cable.

- 2** Turn on the AirStation power.

- 3** Check that the Power LED is on.

If the Power LED does not turn on even after several minutes have elapsed, check that the LAN cable is connected correctly, the AirStation power is turned on, and that the power sourcing equipment is turned on.

## Connecting the AC Adapter (Sold Separately)

If the AC adapter (WLE-OP-AC12, sold separately) is used to supply power to the AirStation, perform the procedure below to connect the AC adapter.

- 1** Connect the AC adapter and AC cable.
- 2** Insert the AC adapter plug into the DC connector of the AirStation.
- 3** Turn on the AirStation power.
- 4** Check that the Power LED is on.

If the Power LED does not turn on even after several minutes have elapsed, check that the AC adapter is connected correctly and that the AirStation power is turned on.

## Initial Setup

---

The AirStation configuration interface can be opened for making the default settings. The AirStation Configuration Tool is used to open the setting screen. Install the AirStation Configuration Tool on your computer, and then open the AirStation configuration interface.

Note: The computer that opens the setting screen must be a Windows computer with Internet Explorer 8.0 or later installed.

## Installing the AirStation Configuration Tool

- 1 Boot your computer and insert the AirNavigator CD. The setup wizard will launch automatically.

Note: If the setup wizard is not displayed, double-click [My Computer] > CD-ROM drive icon > [AirNavi.exe].



Click [Options].



Click [Advanced Installation].

- 4 Check the box for “Install AirStation Configuration Tool” and click [Install].
- 5 Install by following the on-screen instructions.

## Setting the AirStation IP Address

- 1 Start the AirStation Configuration Tool.  
Click [Start] > [All Programs]> [BUFFALO] > [AirStation Utility] > [AirStation Configuration Tool] to launch it.
- 2 Click [Next].

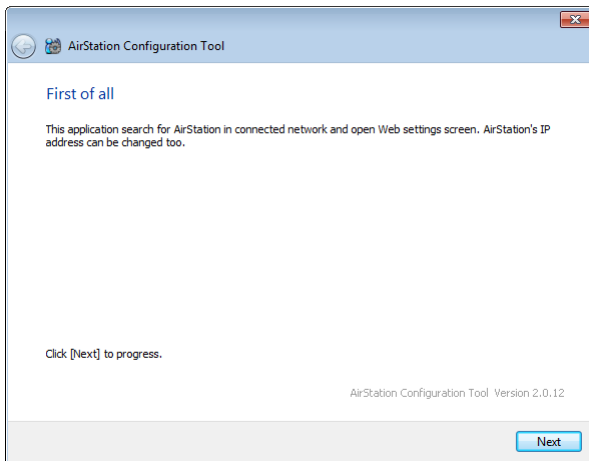

- 3 Highlight an AirStation to configure and click [Next].

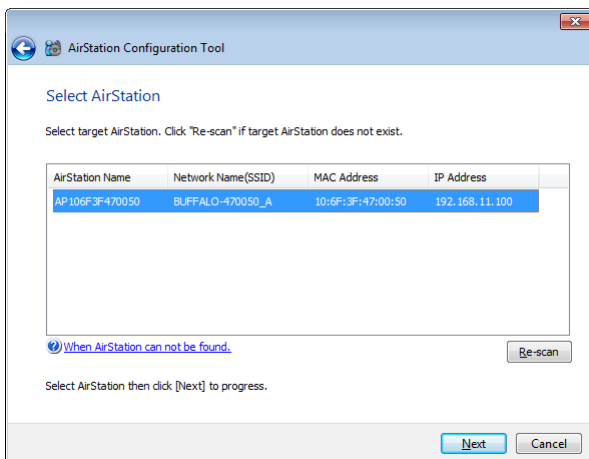

**4** Click [Configure this AirStation IP Address].

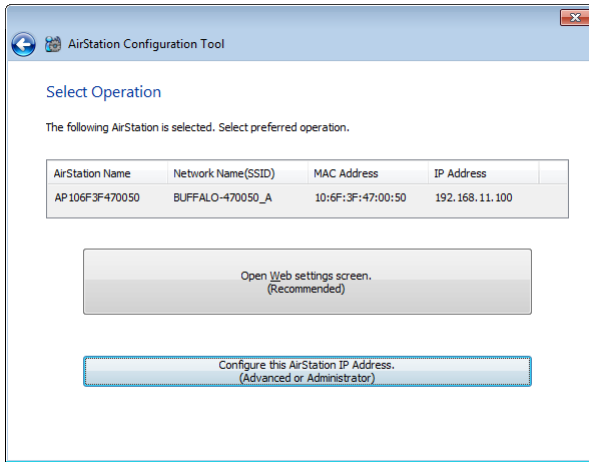

**5** Check “Obtain IP address from DHCP server” to have DHCP obtain an IP address automatically, or you may enter IP address settings manually. Click [Next].

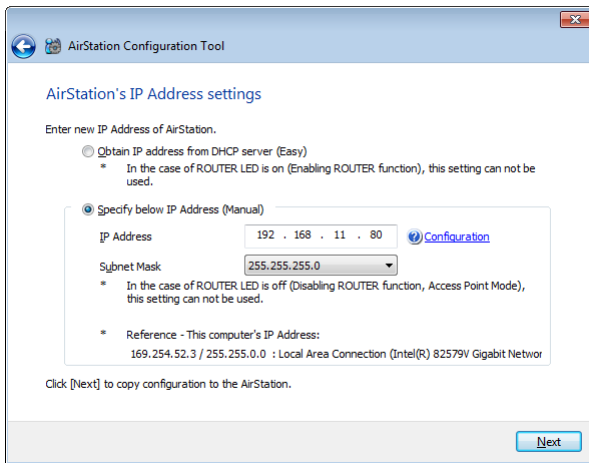

**6** Enter the AirStation administrator password (the default setting is “password”), and click [Next].

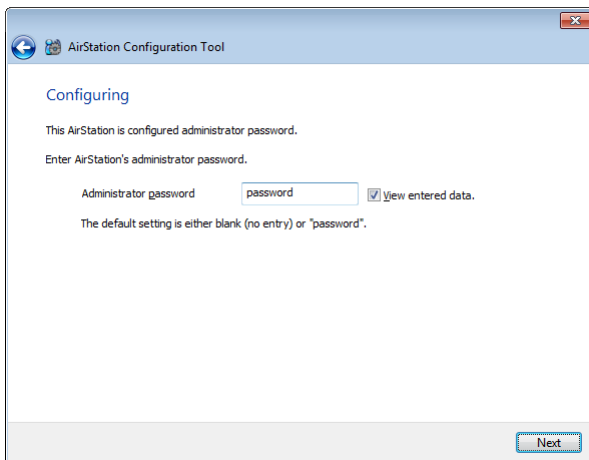

Note: If the AirStation administrator password is 9 characters or more, the IP address of the AirStation cannot be changed using this procedure. In this case, open the AirStation setting screen, and set the IP address.

**7** Click [Finish].

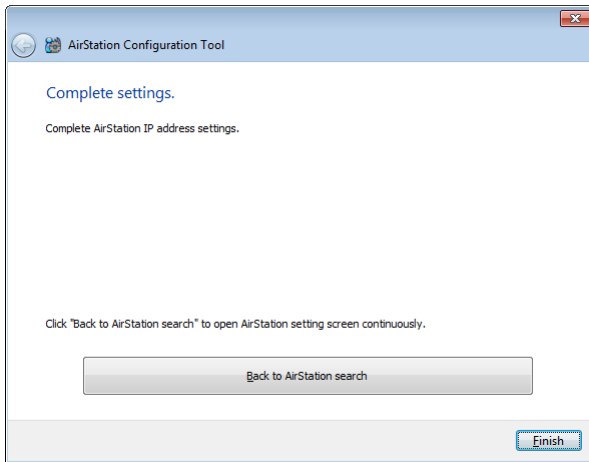

## Accessing the Web-based Configuration Interface

**1** Start the AirStation Configuration Tool.

Click [Start] > [All Programs]> [BUFFALO] > [AirStation Utility] > [AirStation Configuration Tool] to launch it.

**2** Click [Next].

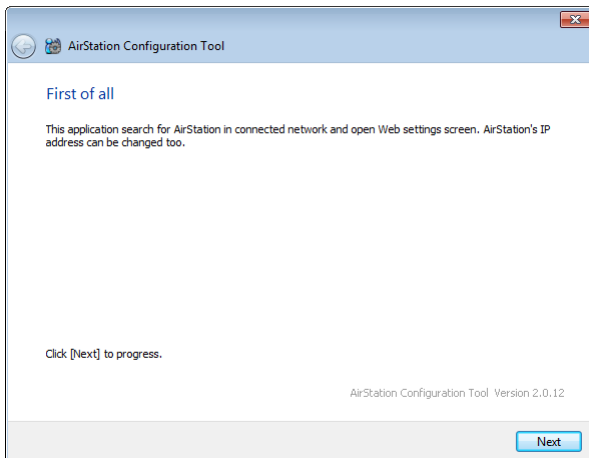

**3** Highlight an AirStation to configure and click [Next].

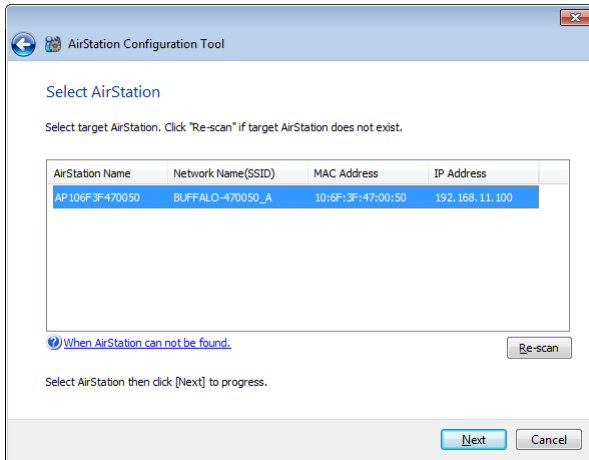

**4** Click [Open Web Setting screen.].

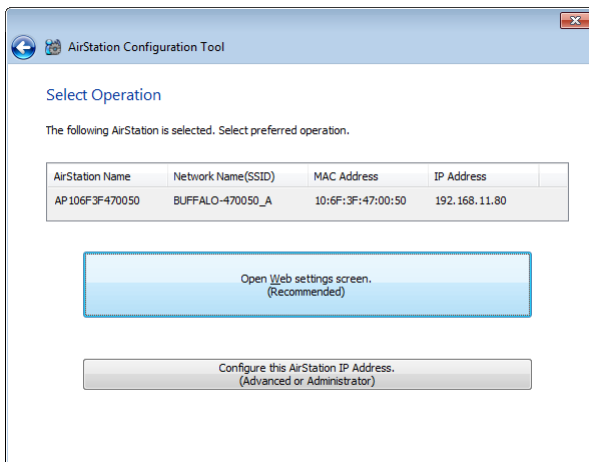

**5** Click [OK].

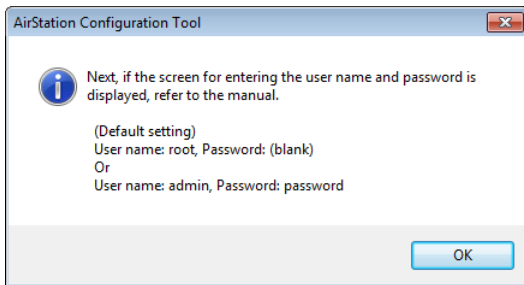



- When the login screen is displayed, enter “admin” for the user name, and enter “password” for the password, and then click [OK].

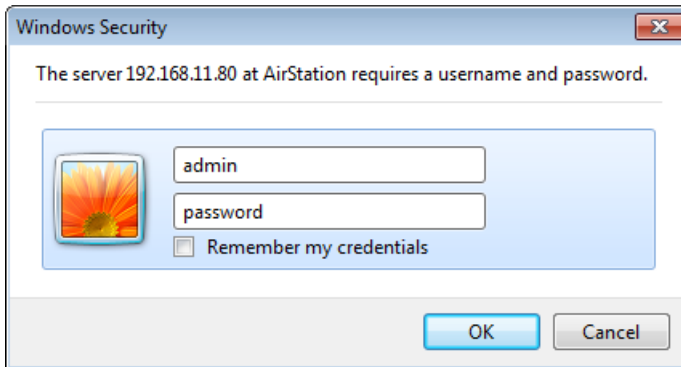

- The AirStation Configuration Interface is displayed.

## Enabling the Wireless LAN Functions and Making the Encryption Settings

In the AirStation default state, all of the wireless LAN functions are disabled. To enable the wireless LAN functions and make the encryption settings, use the procedure below to change the settings.

Note: The example in the procedure below is described when using WPA2-PSK AES for encryption.

- Open the AirStation Configuration interface.
- Click “Wireless Encryption(WEP/TKIP/AES)”.



- For the WAPS-APG600H, select “11a & 11g interfaces”.  
For the WAPS-AG300H, select “11g interface” or “11a interface”.

Encryption Level(WEP/TKIP/AES)

**Selection of a wireless standard to which encryption is set.**

Select the wireless standard to which you wish to set encryption.

A wireless standard to which encryption is set. **11a&11g interfaces**

AirStation supports multiple wireless standards simultaneously or separately. **11a&11g interfaces**  
11g interface  
11a interface

- Select the Security Mode (example: WPA-PSK).

Choose an Encryption Level for this Connection

Security Mode **No Authentication**

NOTE: AES is highly recommended if all your wireless devices support it.

**WPA-PSK**

No Authentication  
WEP  
IEEE802.1x/EAP  
WPA-EAP

- Select “WPA2 Only” for the WPA Type, and select “AES” for the encryption system, set the Pre-Shared Key, and click [Apply].

Choose an Encryption Level for this Connection

Security Mode **WPA-PSK**

WPA Type **WPA2 Only**

Encryption Type **AES**

Pre-Shared Key Type **Passphrase**

Pre-Shared Key **12345678901234567890**

TKIP: TKIP is an encryption method which based on WEP(RC4) and fortify with several vulnerability found on WEP protocol. Wireless clients support with TKIP is needed.

AES: AES is known as one of the most robust encryption method today. Wireless clients supported with AES is needed.

WPA-PSK/WPA2-PSK: WPA-PSK(or WPA2-PSK) authenticates wireless clients' credential with Pre-Shared Key. Only wireless clients which has the same PSK as AirStation will permit to access via AirStation. All wireless clients with supports WPA-PSK(WPA2-PSK) is needed to use these method respectively.

NOTE: AES is highly recommended if all your wireless devices support it.

**Back** **Apply**

## Setting the Password in the Configuration Interface

A user name and password must be entered to log into the configuration interface. If you log into the configuration interface using the administrator name and password, you are provided with privileges for reading and writing all setting parameters and statistical information. The default administrator name is “admin”, and the default administrator password is “password”. To prevent logging in by an unauthorized third party, once the initial setup of the AirStation is completed, be sure to change the administrator password and user password settings.

- 1 Open the AirStation configuration interface.
- 2 Click “Advanced”.

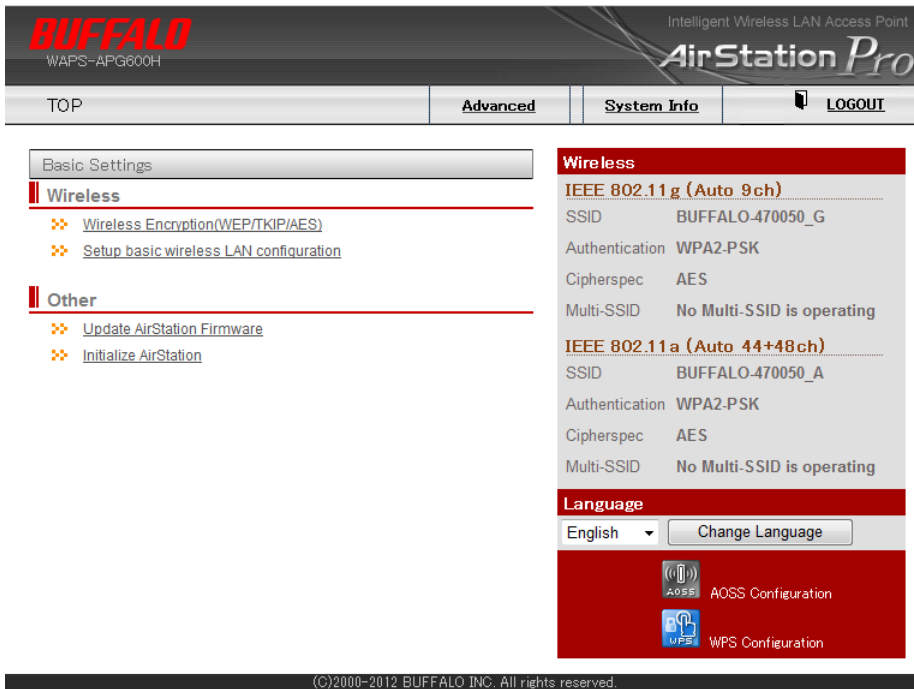

3 From the left-side menu, click “Admin Config” > “Name / Password”.

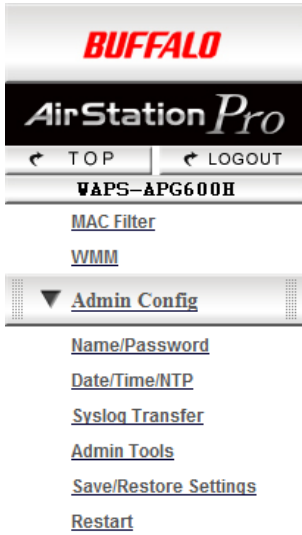

4 Enter a new password for the administrator password and user password (Enter the same password again in the Confirm fields.), then click [Apply].

Name/Password

---

**You can change the password that you use to access the router, this is not your ISP account password.**

Administrator Name	<input type="text" value="admin"/>
Administrator Password	<input type="password" value="••••••"/>
	<input type="password" value="••••••"/> (Confirm)
User Name	<input type="text" value="user"/>
User Password	<input type="password" value="••••••"/>
	<input type="password" value="••••••"/> (Confirm)

- Notes:
- For the “administrator password”, enter a character string of 6 to 32 characters consisting of single-byte alphanumeric characters and symbols.
  - For the “user password”, enter a character string of 6 to 32 characters consisting of single-byte alphanumeric characters and symbols.
  - When setting the passwords, enter both the “administrator password” and “user password”. If one of these passwords is blank, the passwords cannot be set.
  - If you log in using the “administrator name”, all AirStation setting items can be changed.
  - If you log in using a “user name”, you can view all the AirStation setting values, but you cannot change them.

## Mounting to a Ceiling or Wall

The AirStation can be mounted to a ceiling or wall. Pay careful attention to the following points when mounting.

- Notes:
- Mount in a location with an ambient temperature range from 0 °C to 45 °C, humidity from 10 % to 90 %, and no condensation.
  - Do not bring the AirStation into close contact with other devices, other walls, or other objects.
  - Do not mount on wobbly surfaces, slanted surfaces, or other unstable locations.
  - Do not mount in locations that are exposed to large amounts of direct sunlight, heat sources, or electromagnetic waves.
  - Mount in a firm and stable position. If the AirStation is not properly mounted, it can fall and cause an accident.

Use the supplied accessories below to mount the AirStation to the ceiling or wall.

Ceiling-mounting wooden screws (large)

Wall-mounting wooden screws (medium)

- Note: The ceiling where the AirStation is secured must be capable of supporting a weight of at least 1.5 kg. If the ceiling does not have sufficient strength, be sure to reinforce the ceiling before securing the AirStation to it. If the ceiling is not reinforced, the AirStation can fall and cause an injury.

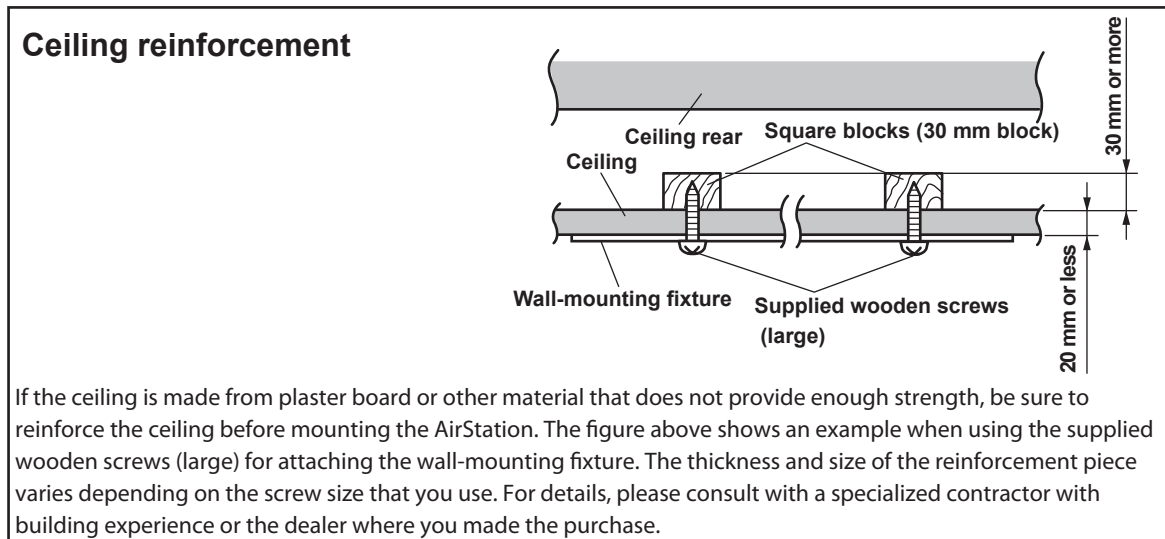

If the screws cannot be properly secured to the wall, such as when the wall material is thin, open holes in the wall beforehand, embed the wall-mounting anchor into the wall, and then secure with the screws.

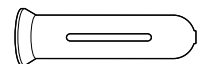

**1** Use the four wooden screws to secure the wall-mounting fixture.

Note: For certain usage environments, you may be able to use items other than the supplied screws. Select the most suitable item for use on your mounting surface.

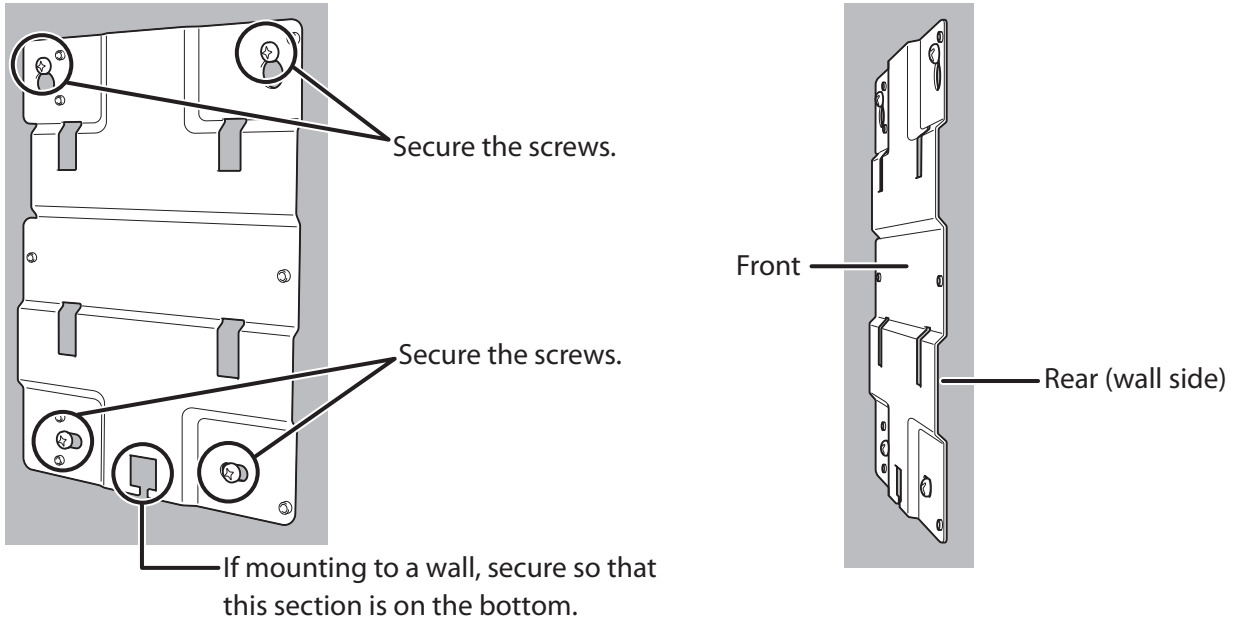

**2** As shown in the figure, insert the AirStation so that it clicks into place, and then secure it in place on the wall-mounting fixture.

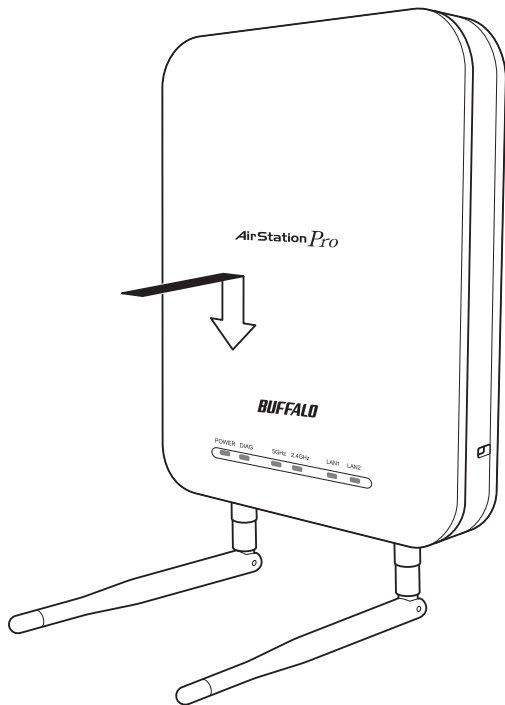

## Mounting the Security Case (Sold Separately)

---

- 1 Use the four wooden screws to secure the fixture to the wall or ceiling.

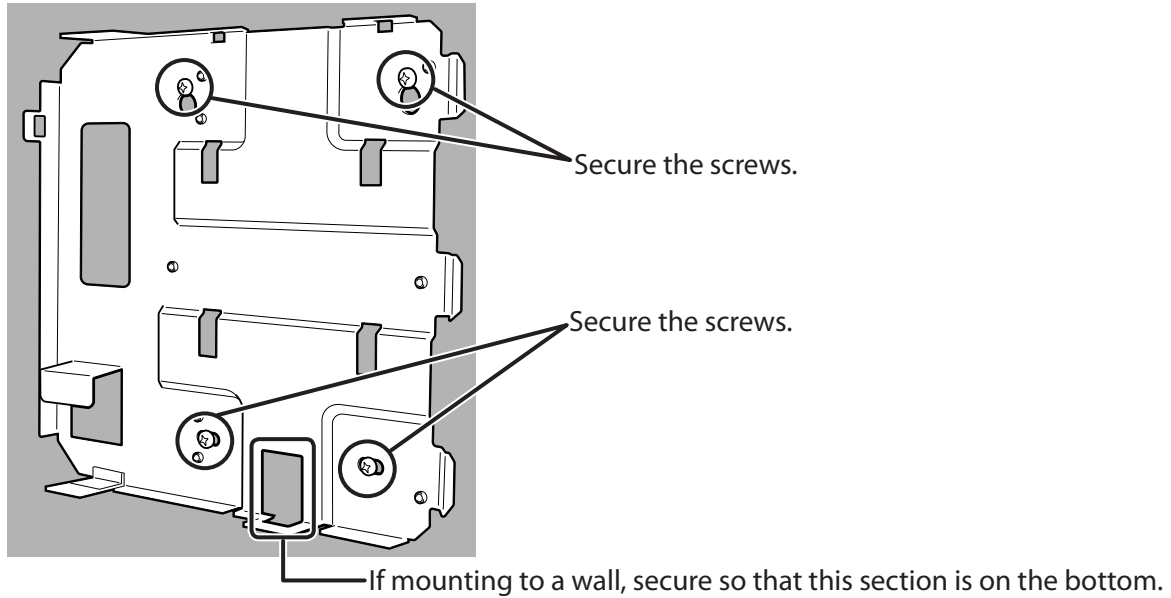

- 2 As shown in the figure, insert the AirStation so that it clicks into place, and then secure it on the wall-mounting fixture.

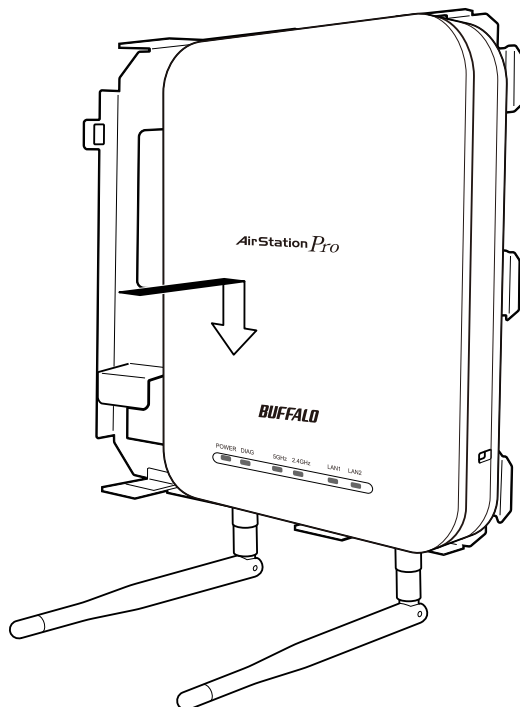

- 3** Insert the key into the cover, and turn to the OPEN position.
- 4** As shown in the figure, attach the cover while it is slanted.

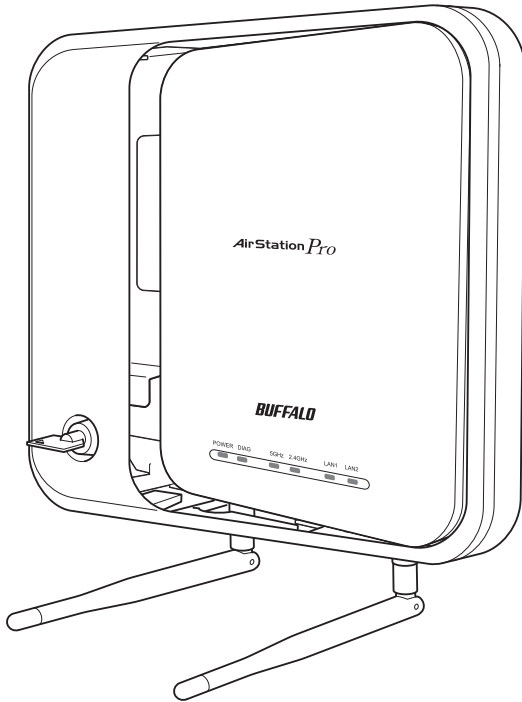

- 5** Turn the key to the CLOSE position, and then remove it.

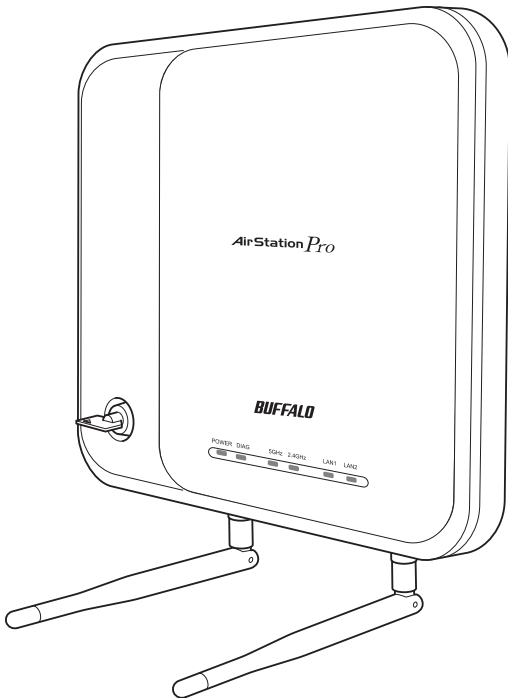



## Removing the AirStation

---

To remove the AirStation from the fixture, perform the procedure below.

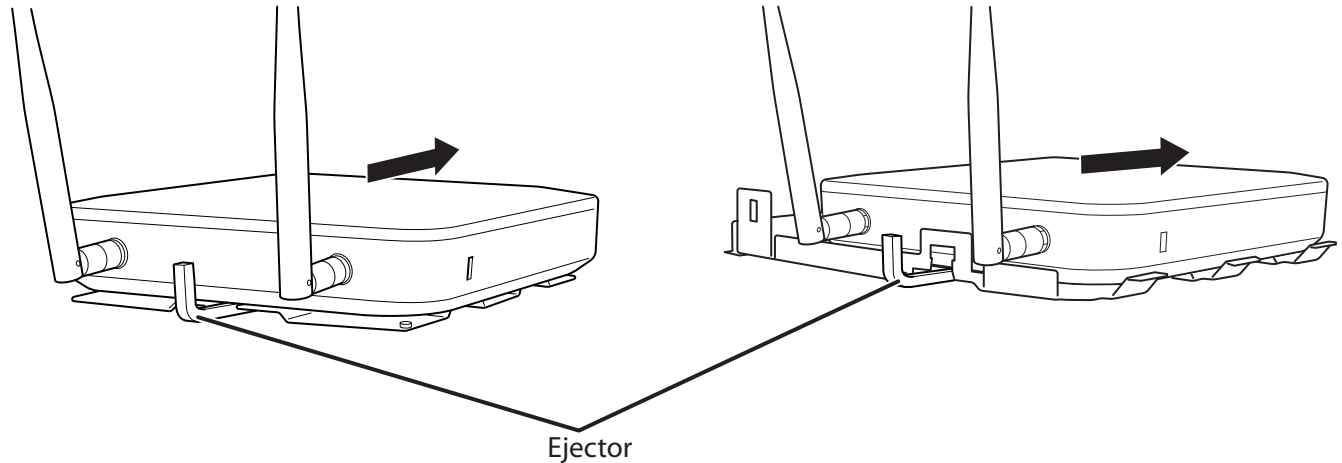

Insert the supplied ejector into the position shown in the figure so that the clips of the AirStation are raised, and then apply force in the direction of the arrow to remove.

If the AirStation is still difficult to remove using this procedure, turn the ejector by about 45 degrees so that the clips on the AirStation are raised, and then apply force in the direction of the arrow to remove.

# Chapter 3 - Connect to a Wireless Network

## Automatic Secure Setup (AOSS/WPS)

---

AOSS and WPS are systems that let you automatically configure wireless LAN settings. Just pressing the buttons will connect wireless devices and complete security settings. Easily connect to wireless devices or computers which support AOSS or WPS.



AOSS (AirStation One-Touch Secure System) was developed by Buffalo Technology. WPS was created by the Wi-Fi Alliance.

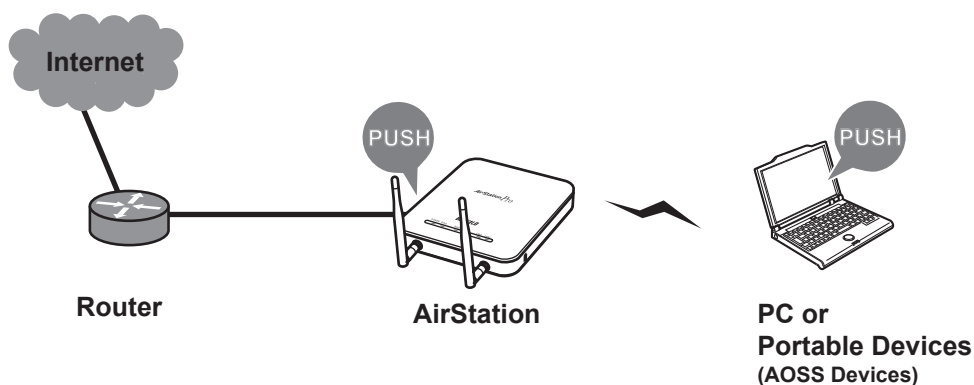

- Before using AOSS/WPS to connect to a Buffalo wireless client, install Client Manager software from the included AirNavigator CD. Consult your wireless client's documentation for more information.
- Buffalo's Client Manager software can be used with the wireless LAN devices built into most computers. However, it is not guaranteed to work with all wireless LAN devices available. Some wireless clients may require manual setup.

## Windows 7/Vista (Client Manager V)

If you are using Windows 7 or Vista, use the included Client Manager V software to connect wirelessly with AOSS/WPS.

**1** Click [Start] > [All Programs] > [BUFFALO] > [AirStation Utility] > [Client Manager V].

**2** Click [Create Profile].

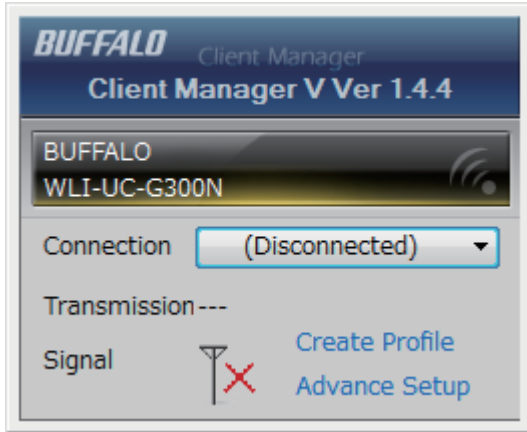

**3** If the User Account Control screen opens, click [Yes] or [Continue].

**4** Click the [WPS AOSS] button.

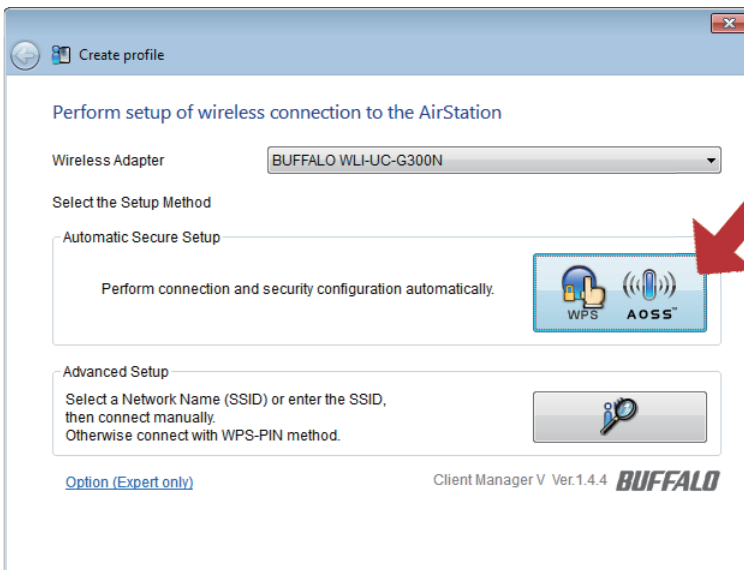

Follow any instructions displayed on the screen. When the 2.4 GHz and 5 GHz LEDs on the front of the AirStation stop flashing and is lit steadily, the connection is complete.

## Windows XP (Client Manager 3)

If you are using Windows XP, use Client Manager 3 to connect wirelessly with AOSS/WPS.

1 Right click on the  icon in the system tray and select [Profile].

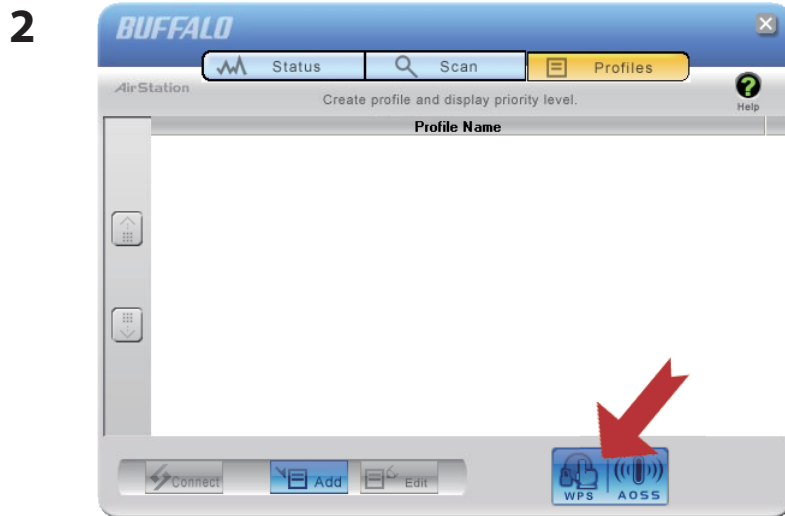

Click the [WPS AOSS] button.

It will take several seconds for your wireless connection to be configured. When the 2.4 GHz and 5 GHz LEDs on the front of the AirStation stop flashing and glow steadily, the connection is complete.

## Mac OS X (AOSS Assistant)

If you are using Mac OS X 10.7 / 10.6 / 10.5 / 10.4, use the included AOSS Assistant software to connect wirelessly with AOSS.

- 1 Load the AirNavigator CD in your Mac.
- 2 From the menu bar, click [Go] > [Computer].
- 3 Double-click the CD icon, and then double-click [AOSS Assistant] in the “Mac” folder.
- 4 The software license screen is displayed. Click [Agree] to proceed.

5

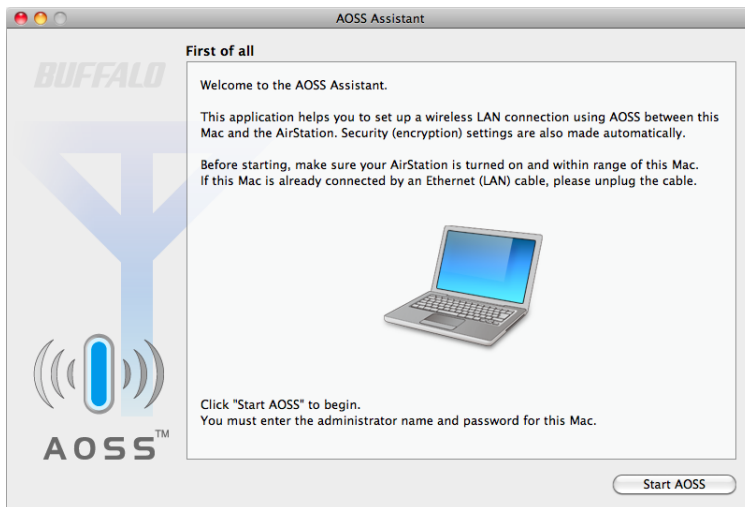

Click [Start AOSS ].

6

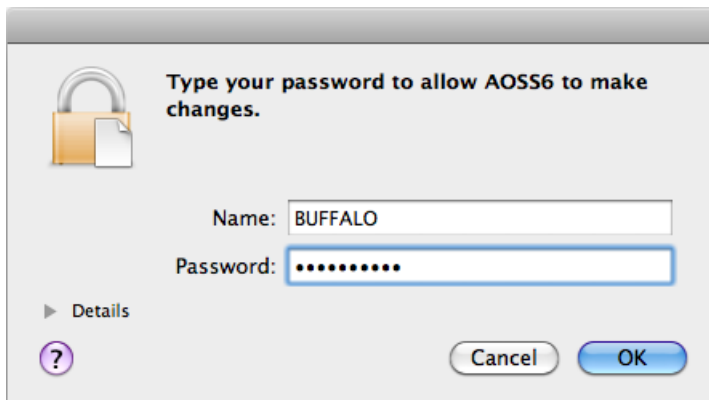

Enter the Mac’s username and password and click [OK].

It will take several seconds for your wireless connection to be configured. When the 2.4 GHz and 5 GHz LEDs on the front of the AirStation stop flashing and glow steadily, the connection is complete.

## Manual Setup

---

You can also connect to the AirStation without installing Client Manager V or Client Manager 3 by using the utility built-in to Windows. The procedure varies depending on which version of Windows you are using.

### Windows 7 (WLAN AutoConfig)

With Windows 7, use WLAN AutoConfig to connect to the AirStation.

- 1 Click on the network  icon in the system tray.

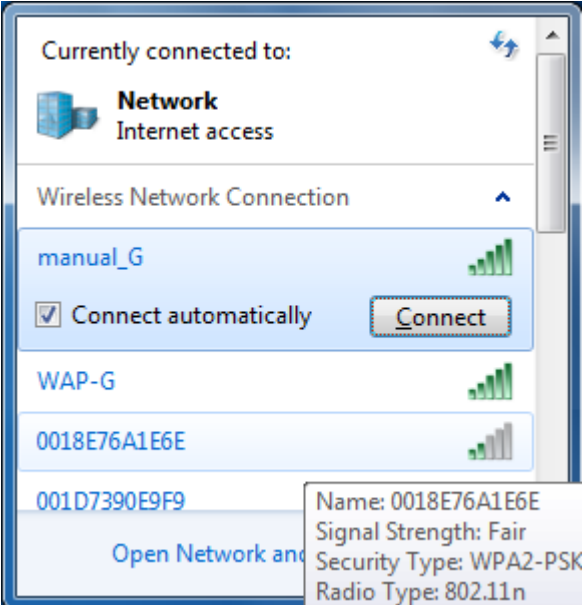
- 2  Select the target AirStation and click [Connect]. If you will be connecting to this device in the future, checking [Connect automatically] is recommended.

**3**

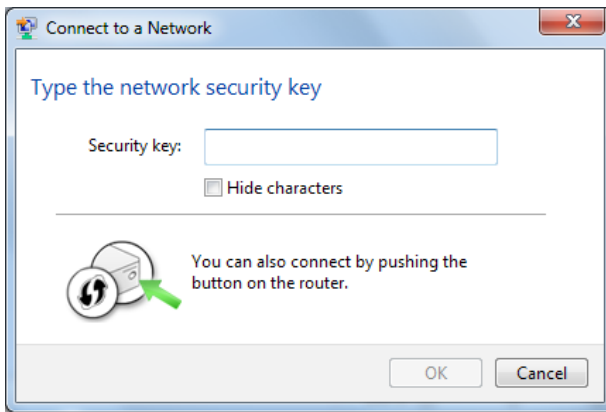

Enter the encryption key and click [OK].

## Windows Vista (WLAN AutoConfig)

With Vista, use WLAN AutoConfig to connect to the AirStation.

**1**

Right click on the wireless network  icon in the system tray.

**2**

Click [Connect to a network].

**3**

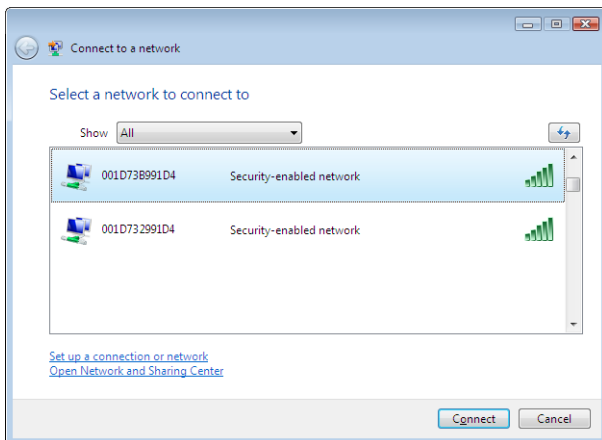

When this screen is displayed, select your network and click [Connect].

If the screen below is displayed, click [I want to enter the network key or passphrase instead]. Otherwise, go to step 4.

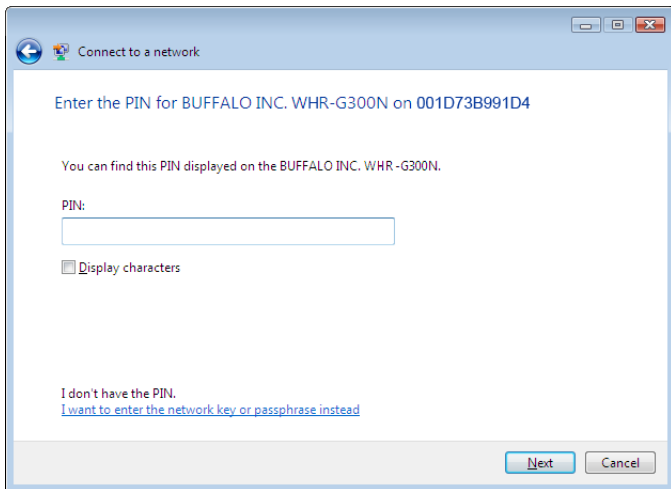
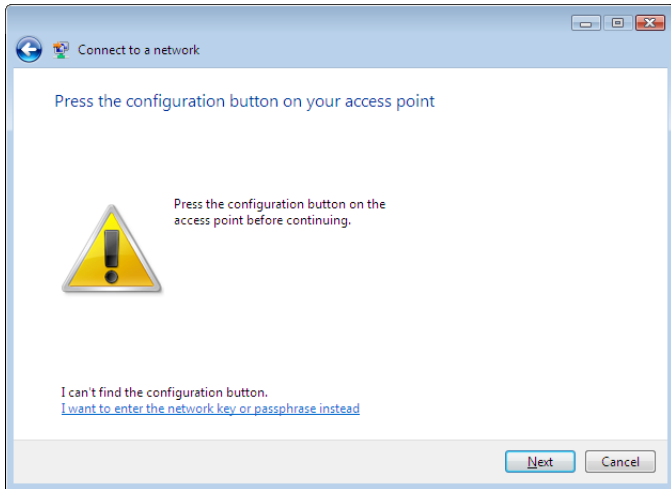



4

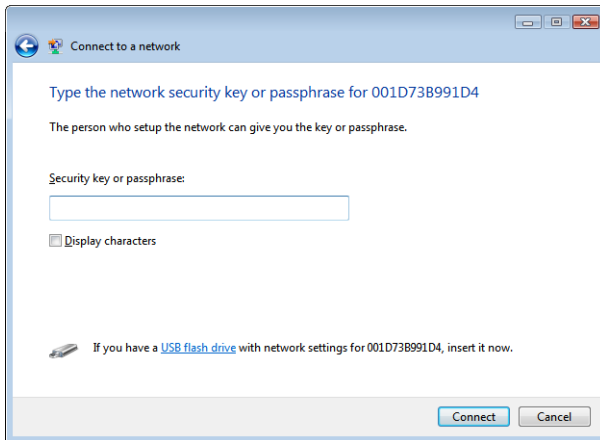

Enter the encryption key and click [Connect].

Step through the wizard to finish configuration.

If the Set Network Location screen is displayed, select [Home], [Work], or [Public location] depending on where you're using the AirStation.

## Windows XP (Wireless Zero Configuration)

Windows XP includes Wireless Zero Config, a built-in utility to connect to your AirStation.

**Note:** If Client Manager 3 is installed on your computer, Wireless Zero Config is disabled. Uninstall Client Manager 3 to use Wireless Zero Config, or just use Client Manager 3 to connect to the AirStation.

**1** Right click on the  wireless network icon in the system tray.

**2** Click [View Available Wireless Networks].

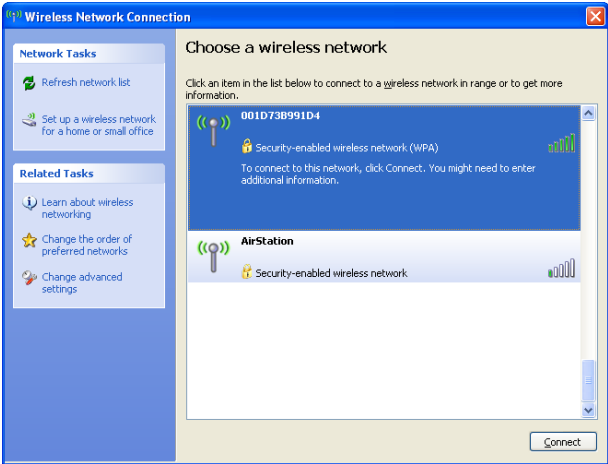
**3**  Select the network to connect to and click [Connect].

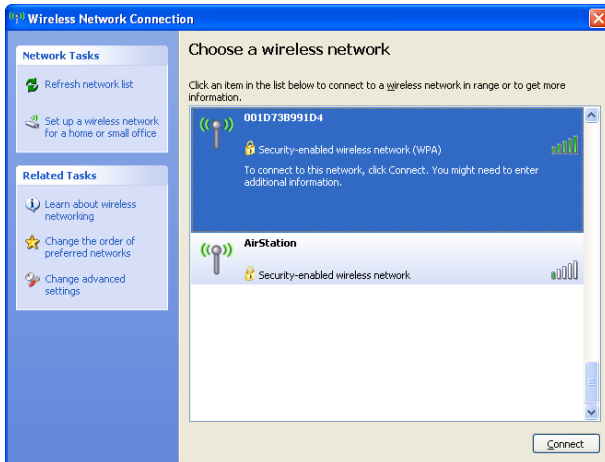

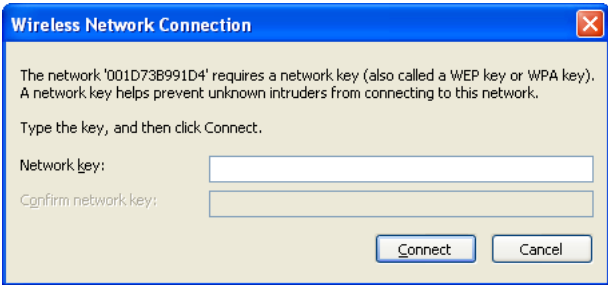
**4**  Enter the encryption key (twice) and click [Connect].

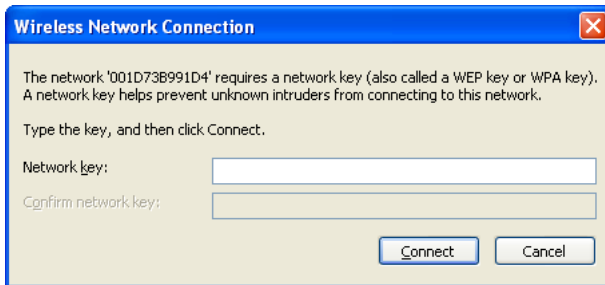



It will take several seconds for configuration to complete.

## Mac OS X (Wi-Fi)

Use Wi-Fi on a Mac to connect to the AirStation.

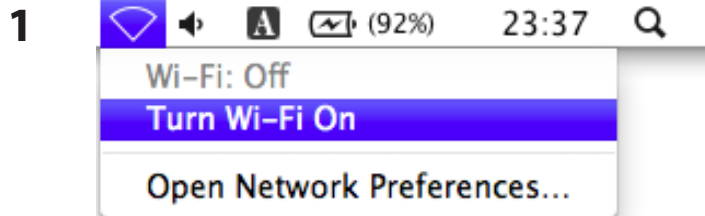
Note: In Mac OS X 10.6 and earlier, “Wi-Fi” appears as “AirPort”.



Click the  icon in the top section of the screen and select [Turn Wi-Fi On].



Find the AirStation's SSID on the list. Click it to highlight it.



Enter the KEY into the Password entry box, check [Remember this network], and click [OK].

It will take several seconds for configuration to complete.

# Chapter 4 - Checking Wireless Signal Quality

For users of Windows 7, Vista, or Mac OS X (10.4 and later), software supplied with the AirStation can be used to check the quality and strength of the wireless signal.

## Windows 7/Vista

- Note:
- If Client Manager V is not already installed, install it from the AirNavigator CD.
  - Client Manager V does not support Windows XP.

1 Click the  icon in the system tray.

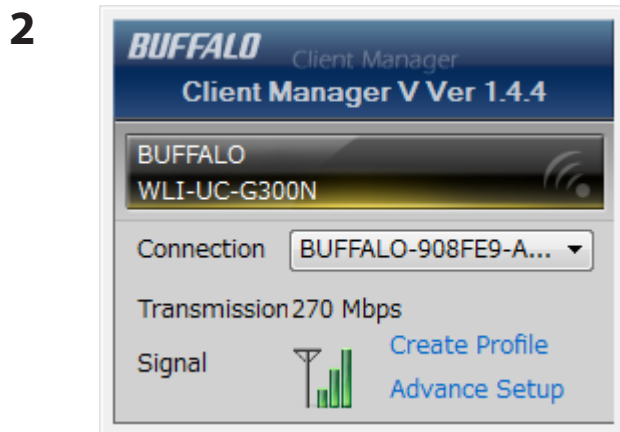

Click [Advanced Setup].

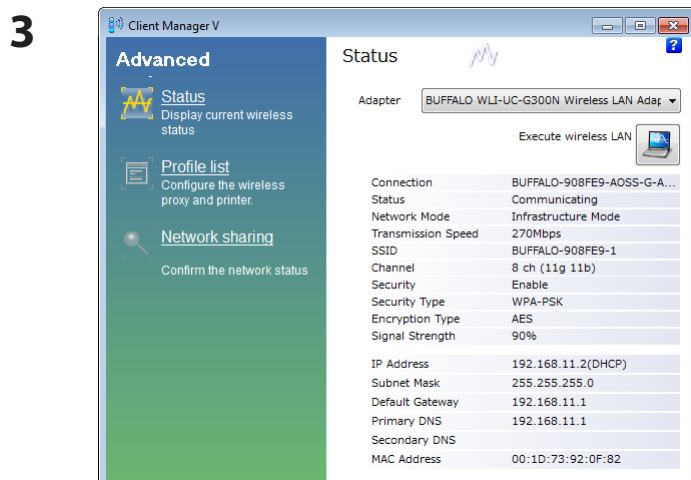

When the Client Manager V status screen is displayed, click .

4

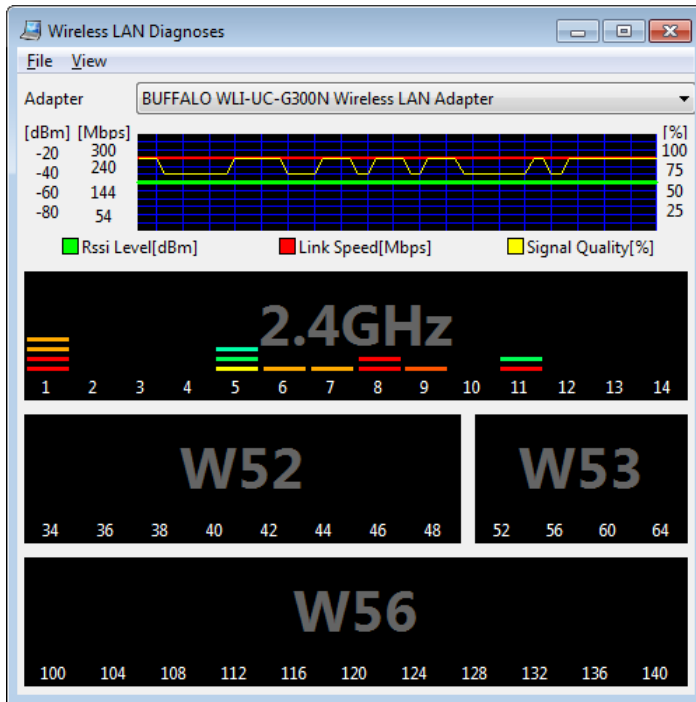

**Parameter**

**Meaning**

Connection status

Signal strength (dBm), link speed (Mbps), and signal quality (%) are displayed in one-minute intervals on a real-time graph.

Usage status by channel

The 11b/11g display shows usage in the 2.4 GHz band channels 1 to 14.  
The 11a display shows usage in the W52, W53, and W56 channels.

Colors are used to indicate the signal strength of the access point. Colors closer to red indicate an access point with a stronger signal strength, and colors closer to blue indicate an access point with a weaker signal strength.

**Mac**

- 1 Load the AirNavigator CD into your Mac.
- 2 From the menu bar, click [Go] > [Computer].
- 3 Double-click the CD icon, and then double-click [WLAN Monitor] in the "Mac" folder.

4 The software license screen is displayed when starting for the first time only. Click [Agree] to proceed.

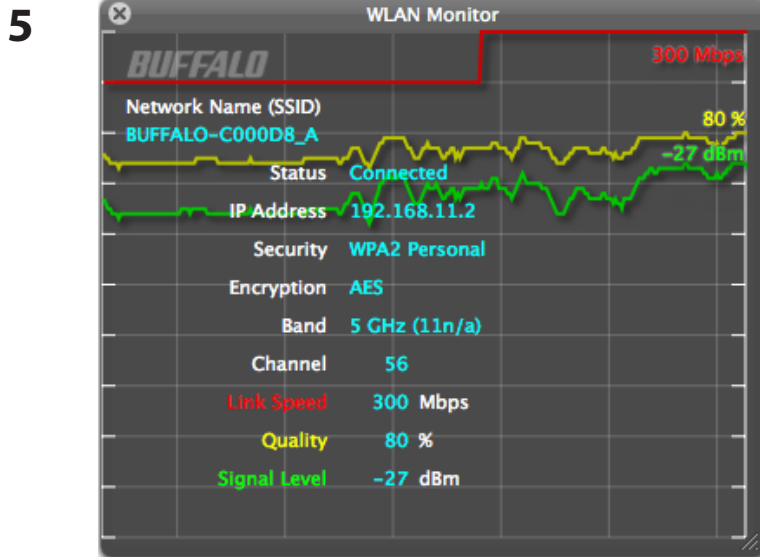

Parameter	Meaning
Network name (SSID)	This displays the SSID of the AirStation that is currently connected.
Status	This indicates the current connection status.
IP Address	This indicates the IP address of the current wireless network port (Wi-Fi).
Security	This indicates the authentication method for the current connection target.
Encryption	This displays the encryption type for the current connection target.
Band	This displays the wireless band for the current connection target.
Channel	This displays the wireless channel for the current connection target.
Link Speed (Mbps)	This displays the current link speed.
Quality (%)	This displays the current signal quality.
Signal Level (dBm)	This indicates the strength of the current signal.

# Chapter 5 - Default Configuration Settings

Feature	Parameter	Default Setting
LAN IP address	IP Assignment	DHCP Client
	IP Address	Assigned by an external DHCP server
	IP Subnet Mask	Assigned by an external DHCP server
	Default Gateway	Assigned by an external DHCP server
	Primary Address	Assigned by an external DHCP server
LAN Port	Wired Port (#1) Wired Port (#2)	Enabled Media Type : Auto MDI : Auto Flow Control : Enabled 802.3az : Enabled
VLAN Config	Interface VLAN	Wired Port (#1) / Wired Port (#2) VLAN mode : Untagged Port VLAN ID : 1
	Management VLAN	VLAN ID : 1
AOSS	AOSS Button on the AirStation Unit	Enabled
	Authentication method for WEP	802.11g : AOSS is not active 802.11a : AOSS is not active
	Authentication method for TKIP	802.11g : AOSS is not active 802.11a : AOSS is not active
	VLAN	802.11g (AES/TKIP) : 1 802.11g (WEP) : 1 802.11a (AES/TKIP) : 1 802.11a (WEP) : 1
WPS	WPS	Disabled
Basic	Radio	802.11g : Disabled 802.11a : Disabled
	Band	802.11g : 11b/g/n 802.11a : 11a/n
	Enable SSID	802.11g : 1 802.11a : 1
	SSID 1	802.11g : BUFFALO-XXXXXX (the last 6 digits of the AirStation's MAC address) + "_G" 802.11a : BUFFALO-XXXXXX (the last 6 digits of the AirStation's MAC address) + "_A"

Feature	Parameter	Default Setting
	VLAN ID	802.11g : 1 802.11a : 1
	Auto Channel	802.11g : Enabled 802.11a : Enabled
	Auto Channel Range	802.11g : 1 - 11 ch 802.11a : W52
	Check Channel Time	802.11g : Half Hour 802.11a : Half Hour
	Channel Bandwidth	802.11g : 20 MHz 802.11a : 40 MHz
	BSS Basic Rate Set	802.11g : 1, 2, 5.5, 11 Mbps 802.11a : 6, 12, 24 Mbps
Advanced	Contention Slot (802.11g only)	802.11g : Short
	Preamble Type (802.11g only)	802.11g : Long
	Guard Interval	802.11g : Short GI 802.11a : Short GI
	802.11g protection (802.11g only)	802.11g : Enabled
	802.11n protection	802.11g : Enabled 802.11a : Enabled
	DTIM Period	802.11g : 1 802.11a : 1
	RTS Threshold	802.11g : 2347 802.11a : 2347
	Fragment Threshold	802.11g : 2346 802.11a : 2346
	Multicast Rate	802.11g : Auto 802.11a : Auto
	Tx Power	802.11g : 100 % 802.11a : 100 %
	Beacon Interval	802.11g : 100 802.11a : 100
	Station Keepalive	802.11g : 60 802.11a : 60
	SM Power Save	802.11g : Disabled 802.11a : Disabled



Feature	Parameter	Default Setting
Security	SSID	802.11g : BUFFALO-XXXXXX (the last 6 digits of the AirStation's MAC address) + "_G" 802.11a : BUFFALO-XXXXXX (the last 6 digits of the AirStation's MAC address) + "_A"
	Broadcast SSID	802.11g : Enabled 802.11a : Enabled
	Privacy Separator	802.11g : No Use 802.11a : No Use
	Load balance (Max associations)	802.11g : 25 / 25 802.11a : 25 / 25
	Security Mode	802.11g : No Authentication 802.11a : No Authentication
	Additional Authentication	802.11g : No Additional Authentication 802.11a : No Additional Authentication
Client List	WLAN Client Table	802.11g : None 802.11a : None
WDS	WDS Function	802.11g : Disabled 802.11a : Disabled
	Local MAC Address	802.11g : - 802.11a : -
	Wireless MAC address of WDS Peer	802.11g : - 802.11a : -
	VLAN mode	802.11g : Untagged Port 802.11a : Untagged Port
	VLAN ID	802.11g : - 802.11a : -
	Encryption	802.11g : None 802.11a : None
RADIUS	Primary RADIUS Server (11g) Secondary RADIUS Server (11g) Primary RADIUS Server (11a) Secondary RADIUS Server (11a)	RADIUS Server IP Address : - Authentication Port : 1812 Shared Secret : - Session-Timeout : 3600 Seconds
MAC Filter	MAC Address Filtering Table	None

Feature	Parameter	Default Setting			
WMM	QoS (priority control)	Disabled			
	WMM-EDCA Parameters (Priority AC_BK (Low) )		For AP	For STA	
		CWMin	4	4	
		CWMax	10	10	
		Aifsn	7	7	
	WMM-EDCA Parameters (Priority AC_BE (Normal) )		For AP	For STA	
		CWMin	4	4	
		CWMax	6	10	
		Aifsn	3	3	
	WMM-EDCA Parameters (Priority AC_VI (High) )		For AP	For STA	
		CWMin	3	3	
		CWMax	4	4	
		Aifsn	1	2	
	WMM-EDCA Parameters (Priority AC_VO (Highest) )		For AP	For STA	
		CWMin	2	2	
		CWMax	3	3	
		Aifsn	1	2	
	Name / Password	Administrator Name	admin		
		Administrator Password	password		
		User Name	user		
User Password		password			
AirStation Name		AP + AirStation's MAC Address			
Management Interface		HTTP : Enabled HTTPS : Enabled SNMP : Disabled			
SNMP Version		v1 / v2c			
SNMP Get community		pubcllc			
SNMP Set community		private			

Feature	Parameter	Default Setting
Date / Time / NTP	Local Time	2012 Year 1 Month 1 Day 0 Hour 0 Minute 0 Second
	NTP Functionality	Disabled
	Server Name	None
	Update Interval	24 hours
	Time Zone	(GMT-6:00) Central America, or (GMT) Greenwich Mean Time: Dublin, Edinburgh, Lisbon, London
Syslog Transfer	Log Transfer	Disabled
	Syslog Server	None
	Transfer log to the USB storage	Disabled
Admin Tools	Registration status	Unregistered
Save / Restore Settings	There are no valid file.	Use the file on the PC
Firmware Update	Update firmware with	Browsing PC
LED Config	Power LED	On
	LAN LED	On
	Wireless LED	On
	USB LED	On

# Appendix A - Specifications

<b>Wireless LAN Interface</b>	
Standard Compliance	IEEE802.11a / IEEE802.11b / IEEE802.11g / IEEE802.11n
Transmission Method	Direct Sequence Spread Spectrum (DSSS), OFDM, MIMO
802.11a Frequency Range	Available 802.11a frequencies depend on the country of purchase. See the next page for details.
802.11g Frequency Range	2,412 - 2,462 MHz (Channels 1 - 11)
Transmission Rate	802.11b: 11, 5.5, 2, 1 Mbps 802.11a/g: 54, 48, 36, 24, 18, 12, 9, 6 Mbps 802.11n 20 MHz BW (Long GI) 130, 117, 104, 78, 52, 39, 26, 13 Mbps (2 stream) 65, 58.5, 52, 39, 26, 19.5, 13, 6.5 Mbps (1 stream) 20 MHz BW (Short GI) 144.4, 130, 115.6, 86.7, 57.8, 43.3, 28.9, 14.4 Mbps (2 stream) 72.2, 65, 57.8, 43.3, 28.9, 21.7, 14.4, 7.2 Mbps (1 stream) 40 MHz BW (Long GI) 270, 243, 216, 162, 108, 81, 54, 27 Mbps (2 stream) 135, 121.5, 108, 81, 54, 40.5, 27, 13.5 Mbps (1 stream) 40 MHz BW (Short GI) 300, 270, 240, 180, 120, 90, 60, 30 Mbps (2 stream) 150, 135, 120, 90, 60, 45, 30, 15 Mbps (1 stream)
Access Mode	Infrastructure Mode, WDS Mode
Security	AOSS, WPA2 (TKIP/AES), WPA (TKIP/AES), WPA/WPA2 mixed PSK, IEEE 802.1X / EAP, 64-bit and 128-bit WEP, Mac Address Filter
<b>Wired LAN Interface</b>	
Standard Compliance	IEEE802.3ab (1000BASE-T), IEEE802.3u (100BASE-TX), IEEE802.3 (10BASE-T)
Transmission Rate	10 / 100 / 1000 Mbps
Transmission Encoding	1000BASE-T 4DPAM5, 100BASE-TX 4B5B/MLT-3, 10BASE-T Manchester Coding
Access Method	CSMA/CD
Speed and Flow Control	10 / 100 / 1000 Mbps, Auto Sensing, Auto MDIX
Number of LAN Ports	2
LAN Port Connector	RJ-45

<b>USB Interface</b>	
Interface	USB 2.0
Connector Type	Type A (plug)
Compliance	5.0 V 500 mA (max 1000 mA)
<b>Other</b>	
Power Supply	External AC 100-240 V Universal, 50/60 Hz Power over Ethernet
Power Consumption	About 12 W (Max)
Dimensions	152 mm x 182 mm x 35mm (5.98 x 7.17 x 1.38 in.)
Weight	440 g (15.52 oz.) (not including antennas)
Operating Environment	0 - 45° C (32 - 104° F), 10 - 90% (non-condensing)

<b>802.11a Frequency Range</b>	
USA Canada	5,180 - 5,240 MHz (Channels 36, 40, 44, 48) 5,745 - 5,825 MHz (Channels 149, 153, 157, 161, 165)
EU Kuwait Saudi Arabia UAE Oman Qatar Egypt	5,180 - 5,240 MHz (Channels 36, 40, 44, 48)
Singapore Australia Hong Kong The Philippines India Thailand Malaysia	5,180 - 5,240 MHz (Channels 36, 40, 44, 48) 5,745 - 5,825 MHz (Channels 149, 153, 157, 161, 165)
South Korea	5,180 - 5,240 MHz (Channels 36, 40, 44, 48) 5,745 - 5,825 MHz (Channels 149, 153, 157, 161, 165)
China	5,745 - 5,825 MHz (Channels 149, 153, 157, 161, 165)
Taiwan	5,745 - 5,825 MHz (Channels 149, 153, 157, 161, 165)

# Appendix B - TCP/IP Settings

## Windows 7

---

To configure TCP/IP in Windows 7, follow the procedure below.

- 1** Click [Start] > [Control Panel] > [Network and Internet].
- 2** Click [Network and Sharing Center].
- 3** Click [Change Adapter Settings] on the left side menu.
- 4** Right-click on [Local Area Connection], then click [Properties].
- 5** If the User Account Control screen opens, click [Yes] or [Continue].
- 6** Select [Internet Protocol Version 4 (TCP/IPv4)] then click [Properties].
- 7** To have DHCP set your IP address settings automatically, check [Obtain an IP address automatically] and [Obtain DNS server address automatically].

To set your IP address settings manually, enter values for each setting. Examples:

If the router's IP address is 192.168.11.1,	
IP address	192.168.11.80
Subnet mask	255.255.255.0
Default gateway	192.168.11.1
Preferred DNS server	192.168.11.1
Alternate DNS server	blank

- 8** Click [OK].

## Windows Vista

---

To configure TCP/IP in Windows Vista, follow the procedure below.

- 1** Click [Start] > [Settings] > [Control Panel].
- 2** Click [Network and Sharing Center].
- 3** Click [Manage network connections] on the left side menu.
- 4** Right-click on [Local Area Connection], then click [Properties].
- 5** If the User Account Control screen opens, click [Yes] or [Continue].
- 6** Select [Internet Protocol Version 4 (TCP/IPv4)], then click [Properties].
- 7** To have DHCP set your IP address settings automatically, check [Obtain an IP address automatically] and [Obtain DNS server address automatically].

To set your IP address settings manually, enter values for each settings. Example:

If the router's IP address is 192.168.11.1,	
IP address	192.168.11.80
Subnet mask	255.255.255.0
Default gateway	192.168.11.1
Preferred DNS server	192.168.11.1
Alternate DNS server	blank

- 8** Click [Close].

## Windows XP

---

To configure TCP/IP in Windows XP, follow the procedure below.

- 1** Click [Start] > [Settings] > [Control Panel].
- 2** Double-click [Network].
- 3** Right click on [Local Area Connection], then click [Properties].
- 4** Select [Internet Protocol (TCP/IP)], then click [Properties].
- 5** To have DHCP set your IP address settings automatically, check [Obtain an IP address automatically] and [Obtain DNS server address automatically].

To set your IP address settings manually, enter values for each setting. Examples:

If the router's IP address is 192.168.11.1,	
IP address	192.168.11.80
Subnet mask	255.255.255.0
Default gateway	192.168.11.1
Preferred DNS server	192.168.11.1
Alternate DNS server	blank

- 6** Click [Close].



## Mac OS X

---

To configure TCP/IP in Mac OS X, follow the procedure below.

- 1** Click [Apple menu] > [System Preferences...].
- 2** Click [Network].
- 3** Click [Ethernet].
- 4** To have DHCP set your IP address settings automatically, select [Using DHCP] in the Configure IPv4 field.

To set your IP address settings manually, select [Manually] in the Configure IPv4 field and enter values for each setting. Examples:

If the router's IP address is 192.168.11.1,	
IP Address	192.168.11.80
Subnet Mask	255.255.255.0
Router	192.168.11.1
DNS Server	192.168.11.1
Search Domains	blank

- 5** Click [Apply].

# Appendix C - Restoring the Default Configuration

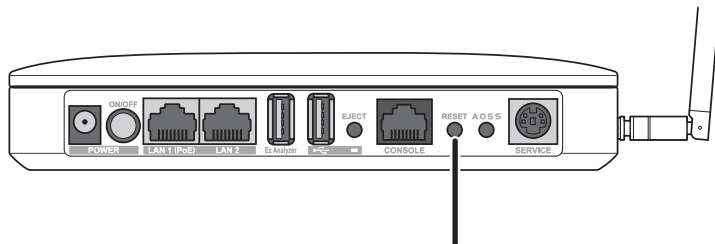

With the AirStation powered on, hold down this button for 3 seconds to return it to factory default settings.

# Appendix D - Regulatory Compliance Information

## Federal Communication Commission Interference Statement

This equipment has been tested and found to comply with the limits for a Class B digital device, pursuant to Part 15 of the FCC Rules. These limits are designed to provide reasonable protection against harmful interference in a residential installation. This equipment generates, uses and can radiate radio frequency energy and, if not installed and used in accordance with the instructions, may cause harmful interference to radio communications. However, there is no guarantee that interference will not occur in a particular installation. If this equipment does cause harmful interference to radio or television reception, which can be determined by turning the equipment off and on, the user is encouraged to try to correct the interference by one of the following measures:

- Reorient or relocate the receiving antenna.
- Increase the separation between the equipment and receiver.
- Connect the equipment into an outlet on a circuit different from that to which the receiver is connected.
- Consult the dealer or an experienced radio/TV technician for help.

## FCC Caution:

Any changes or modifications not expressly approved by the party responsible for compliance could void the user's authority to operate this equipment.

For operation within 5.15 ~ 5.25GHz frequency range, it is restricted to indoor environment.

This device complies with Part 15 of the FCC Rules. Operation is subject to the following two conditions: (1) This device may not cause harmful interference, and (2) this device must accept any interference received, including interference that may cause undesired operation.

## Important Note - FCC Radiation Exposure Statement:

This equipment complies with FCC radiation exposure limits set forth for an uncontrolled environment. This equipment should be installed and operated with minimum distance 20cm between the radiator & your body.

This transmitter must not be co-located or operating in conjunction with any other antenna or transmitter.

The availability of some specific channels and/or operational frequency bands are country dependent and are firmware programmed at the factory to match the intended destination. The firmware setting is not accessible by the end user.

## **Industry Canada statement:**

This device complies with RSS-210 of the Industry Canada Rules. Operation is subject to the following two conditions:

- (1) This device may not cause harmful interference, and
- (2) this device must accept any interference received, including interference that may cause undesired operation.

Ce dispositif est conforme à la norme CNR-210 d'Industrie Canada applicable aux appareils radio exempts de licence. Son fonctionnement est sujet aux deux conditions suivantes:

- (1) le dispositif ne doit pas produire de brouillage préjudiciable, et
- (2) ce dispositif doit accepter tout brouillage reçu, y compris un brouillage susceptible de provoquer un fonctionnement indésirable.

### **Caution:**

The device for the band 5150-5250 MHz is only for indoor usage to reduce potential for harmful interference to co-channel mobile satellite systems.

High power radars are allocated as primary users (meaning they have priority) of 5250-5350 MHz and 5650-5850 MHz and these radars could cause interference and/or damage to LE-LAN devices.

Le dispositif fonctionnant dans la bande 5150-5250 MHz est réservé uniquement pour une utilisation à l'intérieur afin de réduire les risques de brouillage préjudiciable aux systèmes de satellites mobiles utilisant les mêmes canaux.

Les utilisateurs de radars de haute puissance sont désignés utilisateurs principaux (c.-à-d., qu'ils ont la priorité) pour les bandes 5250-5350 MHz et 5650-5850 MHz et que ces radars pourraient causer du brouillage et/ou des dommages aux dispositifs LAN-EL.

## **Important Note - Canada Radiation Exposure Statement:**

This equipment complies with Canada radiation exposure limits set forth for an uncontrolled environment. This equipment should be installed and operated with minimum distance 20cm between the radiator and your body.

## **NOTE IMPORTANTE: (Pour l'utilisation de dispositifs mobiles)**

Déclaration d'exposition aux radiations:

Cet équipement est conforme aux limites d'exposition aux rayonnements IC établies pour un environnement non contrôlé. Cet équipement doit être installé et utilisé avec un minimum de 20 cm de distance entre la source de rayonnement et votre corps.

## **Europe – EU Declaration of Conformity**

This device complies with the essential requirements of the R&TTE Directive 1999/5/EC. The following test methods have been applied in order to prove presumption of conformity with the essential requirements of the R&TTE Directive 1999/5/EC:

EN60950-1: 2006 +A11: 2009  
Safety of Information Technology Equipment

EN50385 : (2002-08)  
Product standard to demonstrate the compliance of radio base stations and fixed terminal stations for wireless telecommunication systems with the basic restrictions or the reference levels related to human exposure to radio frequency electromagnetic fields (110MHz - 40 GHz) - General public

EN 300 328 V1.7.1: (2006-10)  
Electromagnetic compatibility and Radio spectrum Matters (ERM); Wideband Transmission systems; Data transmission equipment operating in the 2,4 GHz ISM band and using spread spectrum modulation techniques; Harmonized EN covering essential requirements under article 3.2 of the R&TTE Directive

EN 301 893 V1.5.1: (2008-12)  
Broadband Radio Access Networks (BRAN); 5 GHz high performance RLAN; Harmonized EN covering the essential requirements of article 3.2 of the R&TTE Directive

EN 301 489-1 V1.8.1: (2008-04)  
Electromagnetic compatibility and Radio Spectrum Matters (ERM); ElectroMagnetic Compatibility (EMC) standard for radio equipment and services; Part 1: Common technical requirements

EN 301 489-17 V2.1.1 (2009-05)  
Electromagnetic compatibility and Radio spectrum Matters (ERM); ElectroMagnetic Compatibility (EMC) standard for radio equipment; Part 17: Specific conditions for Broadband Data Transmission Systems

This device is a 2.4 GHz wideband transmission system (transceiver), intended for use in all EU member states and EFTA countries, except in France and Italy where restrictive use applies.

In Italy the end-user should apply for a license at the national spectrum authorities in order to obtain authorization to use the device for setting up outdoor radio links and/or for supplying public access to telecommunications and/or network services.

This device may not be used for setting up outdoor radio links in France and in some areas the RF output power may be limited to 10 mW EIRP in the frequency range of 2454 – 2483.5 MHz. For detailed information the end-user should contact the national spectrum authority in France.

**CE0700**  

Česky [Czech]

Buffalo Technology Inc. tímto prohlašuje, že tento AirStation WAPS-APG600H / WAPS-AG300H je ve shodě se základními požadavky a dalšími příslušnými ustanoveními směrnice 1999/5/ES.

Dansk [Danish]

Undertegnede Buffalo Technology Inc. erklærer herved, at følgende udstyr AirStation WAPS-APG600H / WAPS-AG300H overholder de væsentlige krav og øvrige relevante krav i direktiv 1999/5/EF.

Deutsch [German]

Hiermit erklärt Buffalo Technology Inc. dass sich das Gerät AirStation WAPS-APG600H / WAPS-AG300H in Übereinstimmung mit den grundlegenden Anforderungen und den übrigen einschlägigen Bestimmungen der Richtlinie 1999/5/EG befindet.

Eesti [Estonian]

Käesolevaga kinnitab Buffalo Technology Inc. seadme AirStation WAPS-APG600H / WAPS-AG300H vastavust direktiivi 1999/5/EÜ põhinõuetele ja nimetatud direktiivist tulenevatele teistele asjakohastele sätetele.

English

Hereby, Buffalo Technology Inc. declares that this AirStation WAPS-APG600H / WAPS-AG300H is in compliance with the essential requirements and other relevant provisions of Directive 1999/5/EC.

Español [Spanish]

Por medio de la presente Buffalo Technology Inc. declara que el AirStation WAPS-APG600H / WAPS-AG300H cumple con los requisitos esenciales y cualesquiera otras disposiciones aplicables o exigibles de la Directiva 1999/5/CE.

Ελληνική [Greek]

ΜΕ ΤΗΝ ΠΑΡΟΥΣΑ Buffalo Technology Inc. ΔΗΛΩΝΕΙ ΟΤΙ AirStation WAPS-APG600H / WAPS-AG300H ΣΥΜΜΟΡΦΩΝΕΤΑΙ ΠΡΟΣ ΤΙΣ ΟΥΣΙΩΔΕΙΣ ΑΠΑΙΤΗΣΕΙΣ ΚΑΙ ΤΙΣ ΛΟΙΠΕΣ ΣΧΕΤΙΚΕΣ ΔΙΑΤΑΞΕΙΣ ΤΗΣ ΟΔΗΓΙΑΣ 1999/5/ΕΚ.

Français [French]

Par la présente Buffalo Technology Inc. déclare que l'appareil AirStation WAPS-APG600H / WAPS-AG300H est conforme aux exigences essentielles et aux autres dispositions pertinentes de la directive 1999/5/CE.

Italiano [Italian]

Con la presente Buffalo Technology Inc. dichiara che questo AirStation WAPS-APG600H / WAPS-AG300H è conforme ai requisiti essenziali ed alle altre disposizioni pertinenti stabilite dalla direttiva 1999/5/CE.

Latviski [Latvian]

Ar šo Buffalo Technology Inc. deklarē, ka AirStation WAPS-APG600H / WAPS-AG300H atbilst Direktīvas 1999/5/EK būtiskajām prasībām un citiem ar to saistītajiem noteikumiem.

Lietuvių [Lithuanian]

Šiuo Buffalo Technology Inc. deklaruoją, kad šis AirStation WAPS-APG600H / WAPS-AG300H atitinka esminius reikalavimus ir kitas 1999/5/EB Direktyvos nuostatas.

Nederlands [Dutch]

Hierbij verklaart Buffalo Technology Inc. dat het toestel AirStation WAPS-APG600H / WAPS-AG300H in overeenstemming is met de essentiële eisen en de andere relevante bepalingen van richtlijn 1999/5/EG.

Malti [Maltese]

Hawnhekk, Buffalo Technology Inc. , jiddikjara li dan AirStation WAPS-APG600H / WAPS-AG300H jikkonforma mal-ħtigijiet essenzjali u ma provvedimenti oħrajn relevanti li hemm fid-Dirrettiva 1999/5/EC.

Magyar [Hungarian]

Alulírott, Buffalo Technology Inc. nyilatkozom, hogy a AirStation WAPS-APG600H / WAPS-AG300H megfelel a vonatkozó alapvető követelményeknek és az 1999/5/EC irányelv egyéb előírásainak.

Polski [Polish]

Niniejszym Buffalo Technology Inc. oświadcza, że AirStation WAPS-APG600H / WAPS-AG300H jest zgodny z zasadniczymi wymogami oraz pozostałymi stosownymi postanowieniami Dyrektywy 1999/5/EC.

Português [Portuguese]

Buffalo Technology Inc. declara que este AirStation WAPS-APG600H / WAPS-AG300H está conforme com os requisitos essenciais e outras disposições da Directiva 1999/5/CE.

Slovensko [Slovenian]

Buffalo Technology Inc. izjavlja, da je ta AirStation WAPS-APG600H / WAPS-AG300H v skladu z bistvenimi zahtevami in ostalimi relevantnimi določili direktive 1999/5/ES.

Slovensky [Slovak]

Buffalo Technology Inc. týmto vyhlasuje, že AirStation WAPS-APG600H / WAPS-AG300H spĺňa základné požiadavky a všetky príslušné ustanovenia Smernice 1999/5/ES.

Suomi [Finnish]

Buffalo Technology Inc. vakuuttaa täten että AirStation WAPS-APG600H / WAPS-AG300H tyyppinen laite on direktiivin 1999/5/EY oleellisten vaatimusten ja sitä koskevien direktiivin muiden ehtojen mukainen.

Svensk [Swedish]

Härmed intygar Buffalo Technology Inc. att denna AirStation WAPS-APG600H / WAPS-AG300H står i överensstämmelse med de väsentliga egenskapskrav och övriga relevanta bestämmelser som framgår av direktiv 1999/5/EG.

## Taiwan:

SAR compliance has been established in typical laptop computer(s) with CardBus slot, and product could be used in typical laptop computer with CardBus slot. Other application like handheld PC or similar device has not been verified, may not comply with related RF exposure rules, and such use shall be prohibited.

## Safety

This equipment is designed with the utmost care for the safety of those who install and use it. However, special attention must be paid to the dangers of electric shock and static electricity when working with electrical equipment. All guidelines of this manual and of the computer manufacturer must therefore be allowed at all times to ensure the safe use of the equipment.

## 根據 NCC 低功率電波輻射性電機管制辦法：

### 第十二條：

經型式認證合格之低功率射頻電機，非經許可，公司、商號或使用者均不得擅自變更頻率、加大功率或變更原設計之特性及功能。

### 第十四條：

低功率射頻電機之使用不得影響飛航安全及干擾合法通信；經發現有干擾現象時，應立即停用，並改善至無干擾時方得繼續使用。前項合法通信，指依電信法規定作業之無線電通信。低功率射頻電機須忍受合法通信或工業、科學及醫療用電波輻射性電機設備之干擾。

5.25-5.35 兆赫頻帶內操作之無線資訊傳輸設備，限於室內使用。

기종별	사용자안내문
B 급 기기 (가정용 정보통신기기)	이 기기는 가정용 (B 급) 전자파적합기기로서 주로 가정에서 사용하는 것을 목적으로 하며, 모든 지역에서 사용할 수 있습니다.



# Appendix E - Environmental Information

- The equipment that you have purchased has required the extraction and use of natural resources for its production.
- The equipment may contain hazardous substances that could impact health and the environment.
- In order to avoid the dissemination of those substances in our environment and to diminish the pressure on the natural resources, we encourage you to use the appropriate take-back systems.
- The take-back systems will reuse or recycle most of the materials of your end life equipment in a sound way.
- The crossed-out wheeled bin symbol invites you to use those systems.



- If you need more information on collection, reuse, and recycling systems, please contact your local or regional waste administration.

# Appendix F - GPL Information

The source code for Buffalo products that use GPL code is available at <http://opensource.buffalo.jp/>.