

ORION®	Universal 1 Transmitter	Installation Data
---------------	--------------------------------	------------------------------

IDENTIFICATION

The ORION® Universal 1 transmitter is available in a three wire pit or remote transmitter configuration for connection to Sensus® ICE™ and ECR II, Neptune® ProRead and E-Coder™, AMCo ScanCoder® and Hersey® Translator encoder registers. All ORION Universal 1 transmitters are shipped from the factory pre-programmed and can be connected to any compatible encoder. Electronic readings broadcast from the ORION Universal 1 transmitter will contain the active number wheels programmed into the encoder, with a maximum of seven digits.

To easily identify an ORION pit or remote Universal 1 transmitter, 'Univ' has been added to the end of the eight-digit ORION serial number. In addition, each ORION Universal pit transmitters will also have a letter 'M' or 'N' at the end of the serial number. This alpha character represents whether the transmitter is for Metal (M) or Nonmetal (N) pit lid applications. It is essential that the correct Universal pit transmitter be used for the correct pit lid application. Failure to do so will result in a violation of FCC regulations.

All ORION Universal 1 transmitters are shipped factory programmed in a sleep mode with a standard cable (10' for remotes and 3' for pits) for connection to a compatible Sensus, Neptune, Hersey or AMCo® encoder. ORION Universal 1 transmitters will begin broadcasting their readings as soon as they are woke up – either by running consumption through the encoder it is connected to or by using the infrared communication program on the ORION reading equipment. If the transmitter will be woke by running consumption, note that it may take an hour for the ORION Universal 1 transmitter to begin broadcasting. This is due to the ORION Universal 1 transmitter update schedule, which has the transmitter updating its reading from the encoder once an hour.

REQUIRED SPLICE TOOLS

- 59983-001 Gel Splice Crimping Tool
- 59989-001 Coax Wire Stripper
Wire Cutter
- 62009-004 Universal 1 ORION Remote Install Kit
- 64394-006 Universal 1 ORION Pit (Thru Lid) Install Kit
- 64394-007 Universal 1 ORION Pit (Below Lid) Install Kit

INSTALLATION

Carefully remove the ORION Universal 1 transmitter from the shipping carton and inspect the unit for damage. Retain the contents of the installation kit for use in mounting and installing the transmitter in the field.

Wiring the ORION Universal 1 Transmitter to Encoder

The ORION Universal 1 pit and remote transmitter is a three-wire AMR device that requires connection to an encoder to complete the assembly. All three wires must be connected to complete the installation.

The ORION Universal 1 transmitter connection can be made to either the existing wires from the encoder or directly to the terminal screws of the encoder depending on the application and manufacturer. If making a connection to existing wires, use the installation kits provided and follow the instructions below.

To connect an encoder with existing wires to an ORION Universal 1 pit or remote transmitter, strip approximately 1 ½" of outer insulation sheath from the encoder and transmitter cables using stripping tool. Badger recommends using part number 59989-001 Coax Stripper, as the stripping tool. Use caution when removing the outer sheath so that the inner signal wire insulation is not nicked or damaged.

Unwind the outer foil shield from the transmitter cable and cut it off even with the outer sheath using a cutting device.

Using the wiring chart below, wire the ORION Universal 1 remote or pit transmitter to an approved encoder according to the following guide lines:

Universal 1 Transmitter Wire	Sensus ECR II, ICE	Neptune ProRead	AMCo ScanCoder
Red	R	B	G
Black	B	G	B
Green	G	R	R

R = Red B = Black G = Green

*Due to the customized factory wire configurations of the Hersey translator, please contact Badger Meter for proper wiring guidelines.

Connect the encoder cable wires to the ORION Universal 1 transmitter wires using the insulation gel connectors provided in the installation kit. Using the chart, determine what wires need to be connected to complete the installation. Note that encoder must be programmed to communicate using Sensus protocol, three wire mode.

⚠ CAUTION

Do not strip any insulation from the ends of the wires before you push them into the connector.

Push the wires that are to be connected together as far as possible into the connector.

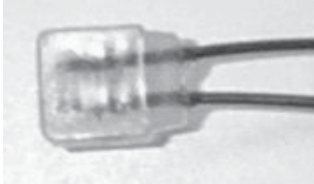

Figure 1

Using the required Gel Splice Crimping Tool, Badger Meter number 59983-001, place the connector with the wires into the jaws of the crimping tool.



Figure 2

Crimp the connector by squeezing the handles until the connector is completely compressed. The crimp tool is designed to prevent applying too much pressure to the gel cap. Continue to apply pressure for three seconds.



Figure 3

Place the two plastic cable ties and tighten securely for strain relief. Remove excess cable tie with the cutting device.

For remote installations, the connection is complete.

For pit installations, place all three connected wires with gel caps into the field splice tube provided in the installation kit. Make sure that the wires with gel caps are inserted as far as possible into the field splice tube. Close the field splice tube. The connection is now complete.

Testing the Wire Connections

The connection of the encoder and ORION® Universal 1 transmitter can be tested using the ORION Data Collector. It is recommended that all wiring connections be tested while on site. To test, place the ORION Data Collector into the ORION Quick Read function. See the Badger Meter installation Manual RAD-IOM-01 for more information on the Quick Read function and how to operate the ORION Data Collector.

Pit Mounting Installation

The ORION Universal 1 pit transmitter is shipped pre-programmed with a factory potted cable that can be connected to any compatible Sensus, Neptune, Hersey or AMCo encoder. Prior to installing an ORION pit transmitter, it is important to determine whether it should be installed in a pit with a metal or a non-metal lid. To determine the type of pit ORION transmitter, look at the serial number tag attached to the wire harness. At the end of the serial number tag attached to the wire harness. At the end of the serial number, either a 'M' for metal or a 'N' for non-metal will designate the proper lid application for the transmitter.

After determining the proper application, the ORION Universal 1 pit transmitter can be installed either through or beneath the lid. An installation kit can be ordered for each transmitter for mounting through or beneath a pit lid. Note that the ORION Universal 1 transmitter should not be mount through the lid in applications where vehicle traffic and exposure to snow plow blades and other equipment may damage the transmitter.

PIT ORION INSTALLATION

The Pit ORION Transmitter (see Figure 4) is shipped with a flying lead ready for connection to an approved competitive encoder. Excess wire should be coiled up inside the pit and cable tied to avoid any damage.

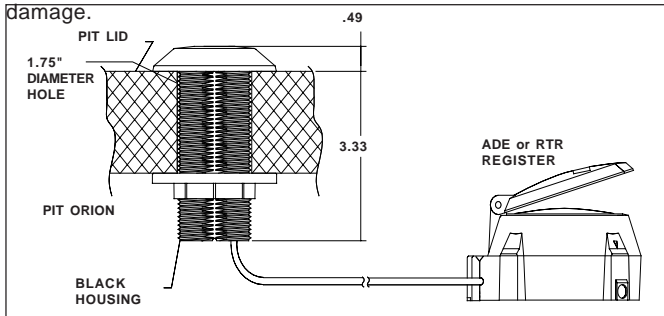

Figure 4 - Identification - Pit ORION Transmitter

ORION Pit transmitters can be mounted through or below the pit lid. See figures 4 and 6 for details. For below the lid installations, a special mounting bracket (Figure 5) is available. This mounting bracket is designed for use with 3/8", 1/2" and 5/8" rebar or 1/2" schedule 40 PVC pipe.

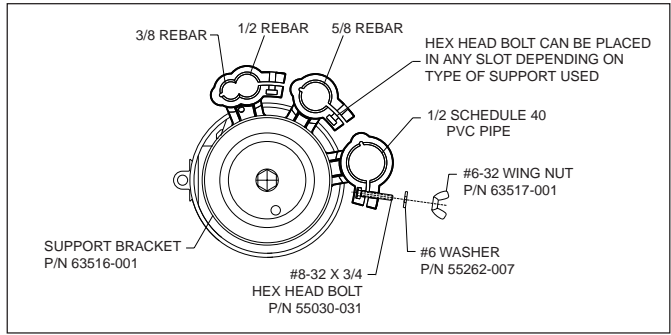

Figure 5 - Identification - Pit Mounting Bracket - Top View

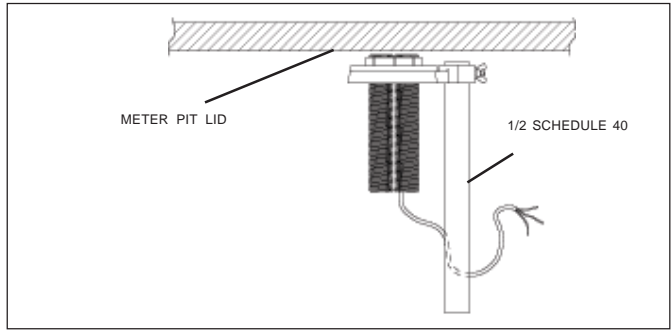

Figure 6 - Identification - Pit ORION Beneath Lid Installation

CAUTION

To install, drive rebar or stake into the ground prior to attaching Pit ORION Transmitter to avoid damage. Once in the ground, secure the mounting bracket on the appropriate rebar or pipe using the enclosed washer, wing nut and hex head bolt provided with the bracket. Thread the bottom-locking nut onto the Pit ORION Transmitter. Insert the Pit ORION Transmitter through the bracket and thread the antenna nut to secure the ORION transmitter (see Figure 6). **For best results mount the Pit Transmitter approximately 1-2" below the underside of the lid.**

NOTE: ORION radio transmitters perform best with a clear line of site and performance will vary by installation and lid construction.

ORION pit transmitters can also be installed in composite and plastic lids like Armourcast. An installation kit for installing an ORION pit transmitter to the lid is available. To install an ORION transmitter to a composite or plastic lid, thread the locking ring onto the top of the Orion transmitter. Slide the transmitter into the mounting bracket. Thread the locking ring so that the transmitter is held firmly in place.

Remote Installation

ORION Universal 1 remote transmitters can be installed in any indoor meter setting, including basement and utility rooms or outdoor installation (not including vault or meter pit installations that are subject to flooding or submergence). When installing an ORION remote transmitter in a basement application, install the unit as high as possible to optimize performance. Do not install ORION transmitters close to metal objects like furnaces, water heaters and appliances, electric equipment or within foil insulation in the rafters.

ORION® is a registered trademark of Badger Meter, Inc. TORX® is a registered trademark of Camcar, Division of Textron, Inc. All other trademarks are trademarks of their respective owners.

Due to continuous research, product improvements and enhancements, Badger Meter reserves the right to change product or system specifications without notice, except to the extent an outstanding bid obligation exists.



Please see our website at www.badgermeter.com for specific contacts.



BadgerMeter, Inc.

P.O. Box 245036, Milwaukee, WI 53224-9536
(800) 876-3837 / Fax: (888) 371-5982
www.badgermeter.com