



BaiCells BRU3510 Base Station Installation Guide

V1.0

About This Document

This document is a user guide for the hardware installation of the base station BRU3510.

Copyright Notice

BaiCells copyrights this specification. No part of this specification may be reproduced in any form or means, without the prior written consent of BaiCells.

Disclaimer

This specification is preliminary and is subject to change at any time without notice. BaiCells assumes no responsibility for any errors contained herein. For more information, please consult our technical engineers.

Revision Record

Date	Version	Description	Author
30 Jun,2016	V1.0		Zhang Luan

Contact Us

Address: 555 Republic Drive, Suite 200 Plano, TX 75074, BaiCells Technologies Co., Ltd.
North America

E-mail: support_na@baicells.com

Phone: +1-972-800-1157

Website: <http://www.baicells.com/>

Contents

1.	Out-of-Box Audit	5
1.1	Shipping List	5
1.2	Appearance	6
1.3	Base Station specifications	6
1.4	Base Station Accessories	7
2.	Installation Preparation	8
2.1	Supporting Materials	8
2.2	Installation Tools	8
2.3	Installation Environment.....	9
2.3.1	Locational Requirements.....	9
2.3.2	Environmental Requirements.....	9
2.3.3	Power Requirements	9
2.3.4	Grounding and Lightning Protection	10
3.	Install Base Station	11
3.1	Installation Procedure.....	11
3.2	Installation Steps.....	11
3.2.1	Install on Wall	11
3.2.2	Install on Pole	13
3.2.3	Install Antenna Feeder System.....	14
3.2.4	(Optional) Install GPS Antenna	20
3.3	Connection Wire	23
3.4	Power On.....	24
3.5	Antennas Information	25
3.6	Regulatory Compliance	26

Content of Figure

Figure 1-1 Appearance of BRU3510	6
Figure 2-1 Grounding and Lightning Protection	10
Figure 3-1 Installation procedure of BRU3510.....	11
Figure 3-2 Install on Wall.....	12
Figure 3-3 Drilling Locations on Wall.....	12
Figure 3-4 Install Mounting Bracket on Base Station.....	13
Figure 3-5 Install Mounting Bracket on Pole	13
Figure 3-6 Installation on Pole Complete	14
Figure 3-7 Omnidirectional Antenna Installation (1).....	15
Figure 3-8 Omnidirectional Antenna Installation (2).....	16
Figure 3-9 Assembling Procedure of Directional Antennas	16
Figure 3-10 Transportation of the Antenna in the Height.....	17
Figure 3-11 Directional Antenna Installation.....	17
Figure 3-12 Antenna Waterproofing	18
Figure 3-13 Antenna Waterproof Protection.....	19
Figure 3-14 Grounding Protection.....	19
Figure 3-15 GPS Antenna Parts.....	20
Figure 3-16 GPS Pole Installation.....	21
Figure 3-17 GPS Cable Fixing	22
Figure 3-18 GPS Connector Connect to Base Station	22
Figure 3-19 Connect Antenna Feeder	23
Figure 3-20 Connect Ethernet Cable	23
Figure 3-21 Connect Power Cable.....	24
Figure 3-22 LED Indicator	24

Contents of Table

Table 1-1 Shipping List	5
Table 1-2 Base Station Specifications	6
Table 1-3 Base Station Accessories	7
Table 2-1 Supporting Materials for Installing Base Station	8
Table 2-2 Environmental Requirements of the Base Station	9
Table 3-1 BRU3510 Indicator Description	24
Table 3-2 BRU3510 Antenna List	25

1. Out-of-Box Audit

1.1 Shipping List

Before opening the box, make sure the packaging cases are in good condition, undamaged and not soaked. During the unpacking, avoid potential damaging impacts from hits or excessive force.

Once unpacked, check the quantity to see if it is consistent with that in the shipping list shown in Table 1-1.

Table 1-1 Shipping List

Number	Item	Quantity	Description
1	BRU3510 base station	1	Check the device's tag to see if it is consistent with the requirement
2	Power supply	1	100V~277V AC to -48V DC adaptor
3	Mounting bracket	2	Fixed accessories
4	Warranty	1	-
5	Certification	1	-
6	User guide	1	-
7	Waterproof accessories	1	-

Note:

During the unpacking, if the outer package is damaged or soaked, stop unpacking and find the cause. Report the issue to the vendor. For any shortage, miscarriage, or damage is identified, report the local vendor within 10 days.

1.2 Appearance

Figure 1-1 shows the appearance of BRU3510 base station.

Figure 1-1 Appearance of BRU3510



Dimension: 440mm (length) x 240mm (width) x 140mm (height)

Weight: about 11kg

1.3 Base Station specifications

Table 1-2 shows the specifications of the BRU3510 base station.

Table 1-2 Base Station Specifications

Item	Description
Working Mode	LTE TDD
Working Frequency	FCC: 2496MHz~2690MHz IC: 2500MHz~2690MHz
Working Bandwidth	10MHz/20MHz
Max Tx Power	43dBm
Receiving Sensitivity	1. 10MHz: -102 dBm 2. 20MHz: -102 dBm
MIMO	2*2MIMO

1.4 Base Station Accessories

Table 1-3 shows the accessories of the BRU3510 base station.

Table 1-3 Base Station Accessories

Accessory	Name
 A black power adaptor with a silver metal heat sink. The label on the heat sink reads "INVENTRONICS" and includes technical specifications like "AVAIL. 5A 25A", "CE", "E", "S&LV", and "TYPE II".	Power adaptor
 Two spools of black Ethernet cables. The ends of the cables are shown with four colored wires (red, green, blue, orange) protruding from the black sheath.	Ethernet Cable Size: 53mm*100mm*45mm
 A collection of installation accessories including several metal screws and nuts, a roll of white 3M VHB tape, a black mounting bracket, a green terminal block, a black power cord, and a black circular component.	Installation Accessories Including mounting bracket, screw, nut, water-proof tape, and so on.

2. Installation Preparation

2.1 Supporting Materials















Prepare accordingly the following supporting materials, given as Table 2-1.

Table 2-1 Supporting Materials for Installing Base Station

Name	Description
Power line	< AWG16, e.g., AWG14 Shorter than 350m (1150 feet)
Antenna feeder	50 ohm feeder
Cable	Outdoor CAT5, CAT5e
Antenna	Omnidirectional, or directional antenna
Ground wire	16mm ² yellow/green wire
GPS	GPS antenna, N type cable, and GPS mounting bracket

2.2 Installation Tools

The following tools are needed during the installation.

				
Level bar	Marking pen	Knife	Vice	Wrench
				
Percussion drill and some drill heads	hammer	Cross screwdriver	Cable vice	Tape measure
				
5mm L-shape allen hexagon wrench	Water-proof tape	Insulating tape	Ladder	

2.3 Installation Environment

2.3.1 Locational Requirements

Environments with high-temperature, harmful gases, unstable voltage, big vibration, high noise or exposed to flammable, explosive, electromagnetic interference (large radar station, transmitting station, transformer substation) are not suitable for the operation of BRU3510, and thus should be avoided. Places prone to have impounded water, soaking, leakage, or condensation, should also be avoided.

In the construction process, factors like climate, hydrology, geology, earthquake, electric power, and transportation should be taken into consideration so that a proper location can be chosen to meet the communication engineering environmental requirements, as well as the technical requirements of network planning and communication equipment.

2.3.2 Environmental Requirements

Table 2-2 gives the base station's environmental requirements on temperature, humidity, and voltage.

Table 2-2 Environmental Requirements of the Base Station

Item	Range	Typical value
Humidity	-35°C ~ 55°C	25°C
Relative humidity (no condensation)	0% ~ 100%	5% ~ 100%
Safety voltage	- 58V ~ -42V	-48V

2.3.3 Power Requirements

BRU3510 base station adopts -48V DC power supply. For the safety and reliability of device, we have the following suggestions.

- Remote DC power supply, in general, AC power supply is 100V ~ 270V, the distance of AC power supply to the device is less than 30 meters.
- If the static exceeds a certain range, it will lead to great damage to the circuit and the whole device.

2.3.4 Grounding and Lightning Protection

BRU3510 base station built-in lightning protection function. When the base station is installed, connect the grounding wire to ground, that is, connecting yellow-green ground wire to GND terminal of base station with screw. After installation, you should make some anti-corrosion and anti-rust measures, such as welding on tin. And the ground wire connects to the ground point. The ground wire is not smaller than 16 mm², as short as possible, do not coil round. Figure 2-1 shows the grounding.

Figure 2-1 Grounding and Lightning Protection

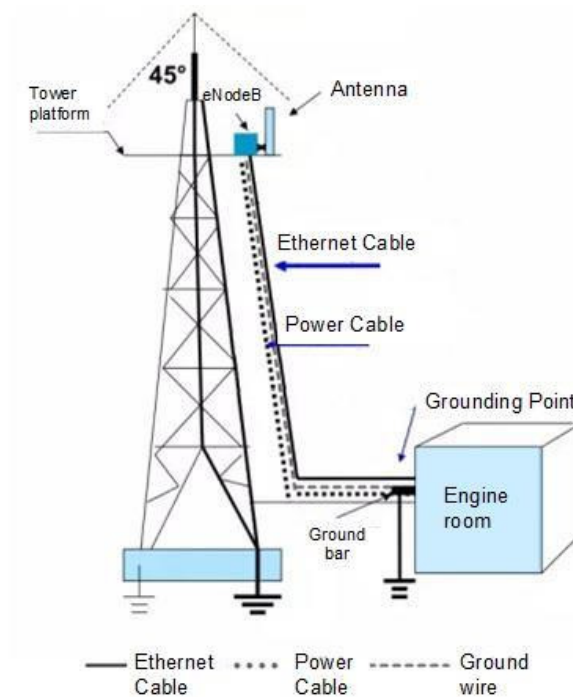

3. Install Base Station

3.1 Installation Procedure

BRU3510 base station as a wireless device, the rationality of installation directly influence the coverage effect of wireless signal. Therefore, the installation need to complete by professionals to meet the installation requirements. The installation procedure is shown in Figure 3-1.

Figure 3-1 Installation procedure of BRU3510

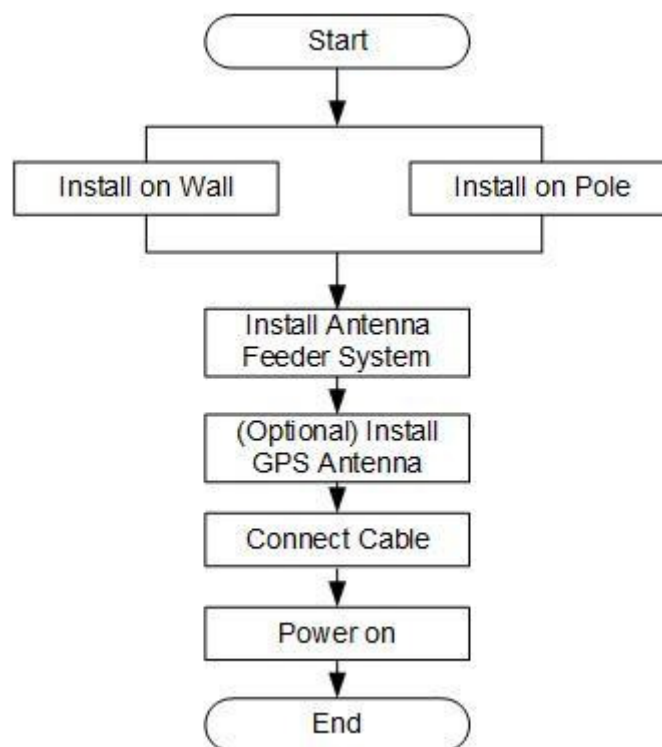

3.2 Installation Steps

BRU3510 base station supports install on wall and install on pole, the following introduces each of them.

3.2.1 Install on Wall

1. Fix three mounting hooks on both ends of the base station with M6*16 screw, as shown in Figure 3-2.

Figure 3-2 Install on Wall

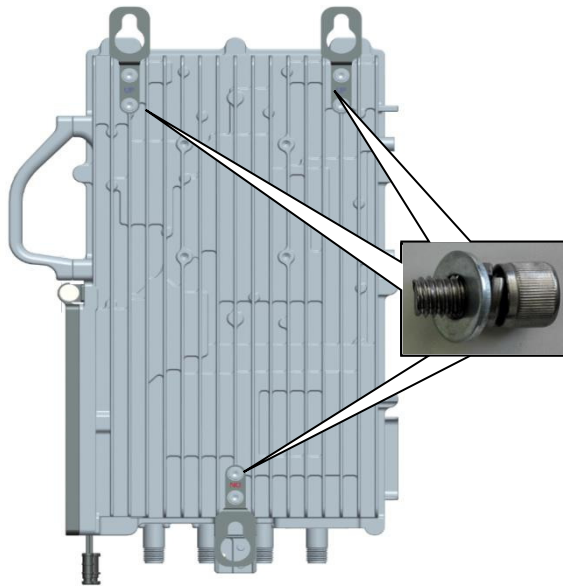

2. Put the base station having installed mounting hook on the wall, mark the drilling locations, as shown in Figure 3-3.

Figure 3-3 Drilling Locations on Wall

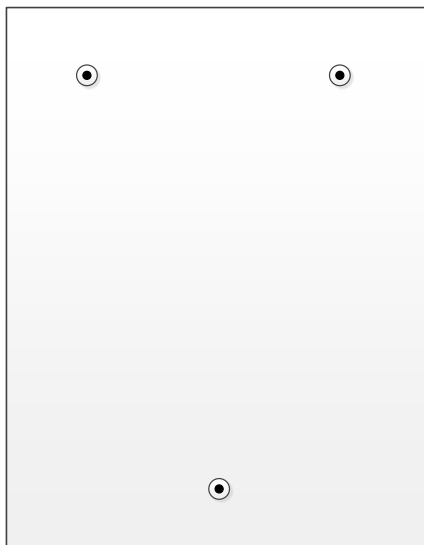

3. Drill three holes on the wall of the size 12mm in diameter by following the locations marked.
4. Fix the base station on the wall using M10*80 expansion screws.

3.2.2 Install on Pole

1. Fix the mounting bracket with M6*16 screw on base station, as shown in Figure 3-4.

Figure 3-4 Install Mounting Bracket on Base Station

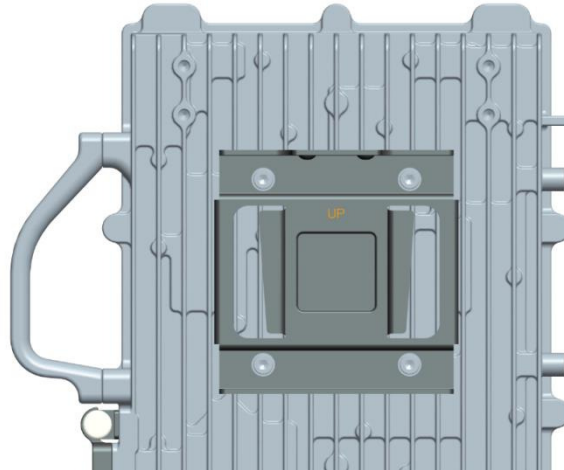

2. Install mounting bracket on pole, as shown in Figure 3-5.

Require the diameter of pole is 30mm~100mm.

Figure 3-5 Install Mounting Bracket on Pole

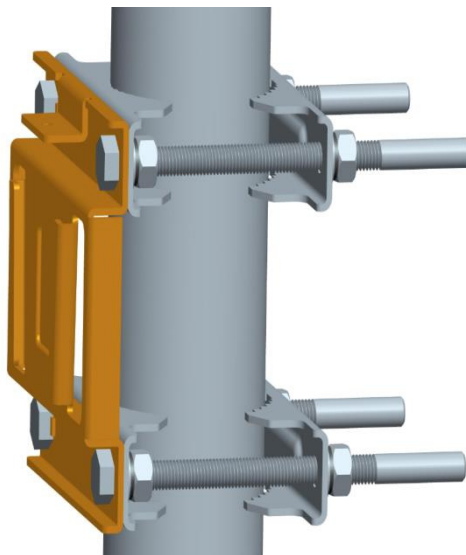

3. Insert vertically the base station into mounting bracket on pole, fasten M6 fixed screw, and installation on pole is complete, as shown in Figure 3-6.

Figure 3-6 Installation on Pole Complete

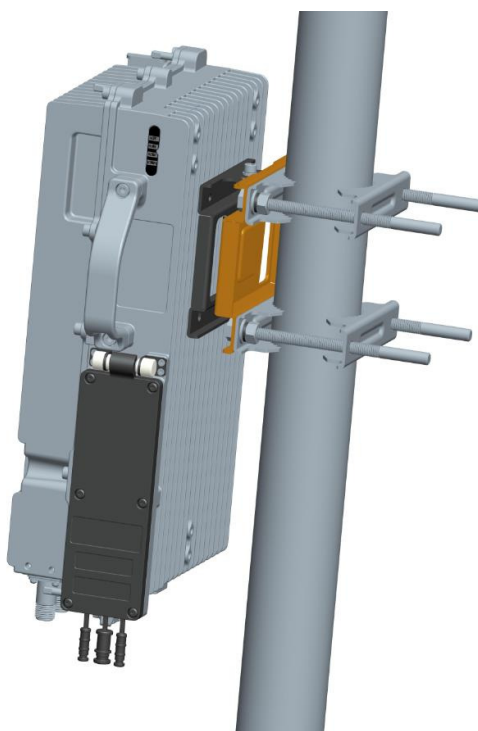

3.2.3 Install Antenna Feeder System

There are two kinds of outdoor antennas, omnidirectional outdoor antennas and directional outdoor antennas, which installation will be introduced in the following respectively.

3.2.3.1 Install Omnidirectional Antennas

One should pay attention to the followings in the process of installing omnidirectional outdoor antenna:

- The diameter of the pole for omnidirectional outdoor antennas is required to be 35mm ~ 50mm. A typical case is to use the 50mm diameter round-steel-made pole (with details depending on the specific antenna type).
- Make sure that the top of pole and the clamp beneath the antenna are at the same level, after installing the omnidirectional outdoor antenna on the pole.
- Make sure that the antenna is high enough to meet the coverage requirement, and that, the antenna top falls in the safety angle of 45 degrees towards the lightning rod, as shown in Figure 3-7.

Figure 3-7 Omnidirectional Antenna Installation (1)

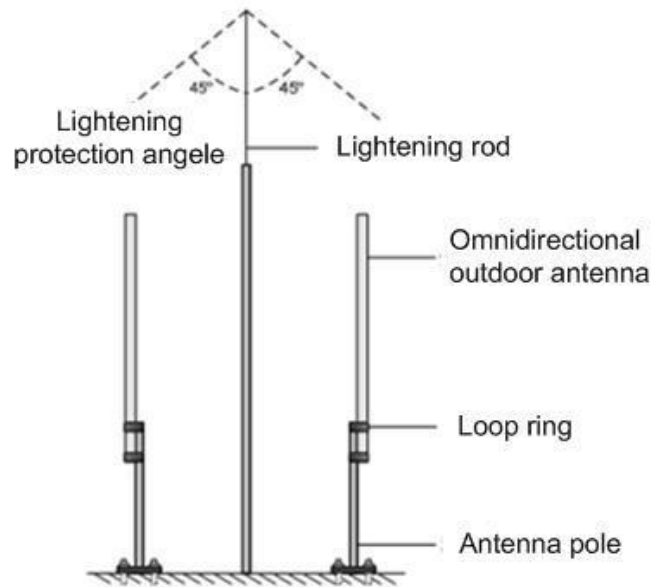

- In principle, no lightning rod can be welded to pole (no metal object is allowed within 1m range in the horizontal direction of the omnidirectional antennas), when installing the omnidirectional antennas. Instead, an independent lightning rod should be settled between two poles, where the lightning rod must be high enough to keep all antenna tops under its protection cover.
- In case that an independent lightning rod is impossible due to environmental limitation, the installation method as shown in Figure 3-8 can be adopted. Be aware that the pole supporting the lightning rod should be kept from the omnidirectional outdoor antennas for at least 1m away.

Figure 3-8 Omnidirectional Antenna Installation (2)

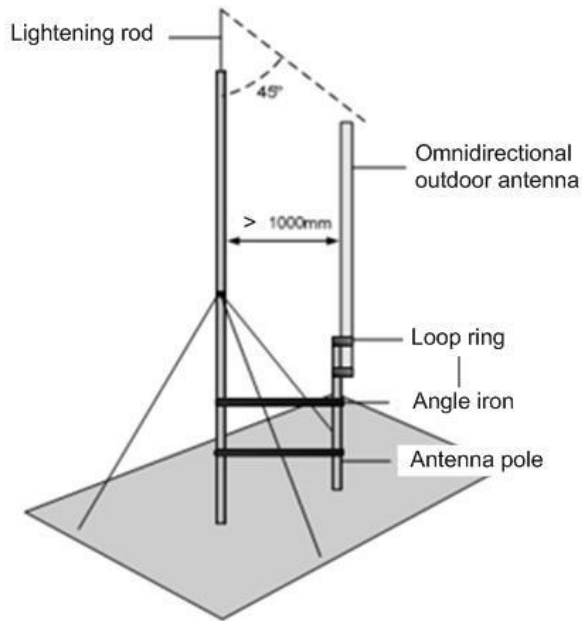

3.2.3.2 Install Directional Antennas

1. First, assemble the antennas, as shown in Figure 3-9.

Figure 3-9 Assembling Procedure of Directional Antennas



2. Use pulley to transport the antenna assembled to the platform at the iron tower, as shown in Figure 3-10. Working at heights should strictly follow the safety rules.

Figure 3-10 Transportation of the Antenna in the Height

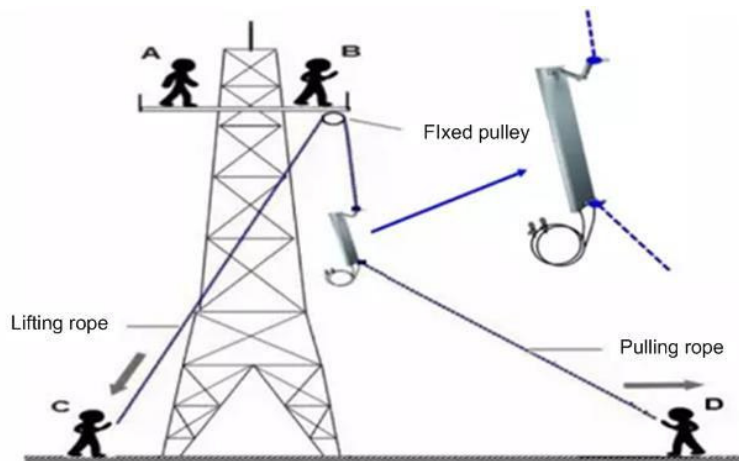

3. Fix the pole vertically to the ground or concrete pillars on the rooftop using expansion screws, and fasten it with steel wires. Then, mount the directional outdoor antenna onto the pole using the installation rack, as shown in Figure 3-11.

Figure 3-11 Directional Antenna Installation

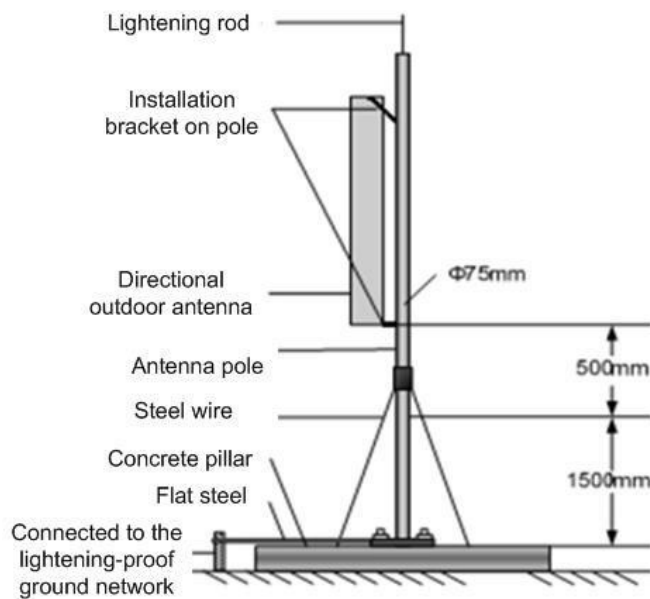

4. Connect all cables and wires and fix them, when the base station has been installed in a proper position.
5. Do testing, and seal all the connections for waterproof protection after the testing is passed.

3.2.3.3 Waterproof Protection

Wrap the connections to protect with waterproof tapes and waterproof daub, as shown in Figure 3-12.

Figure 3-12 Antenna Waterproofing

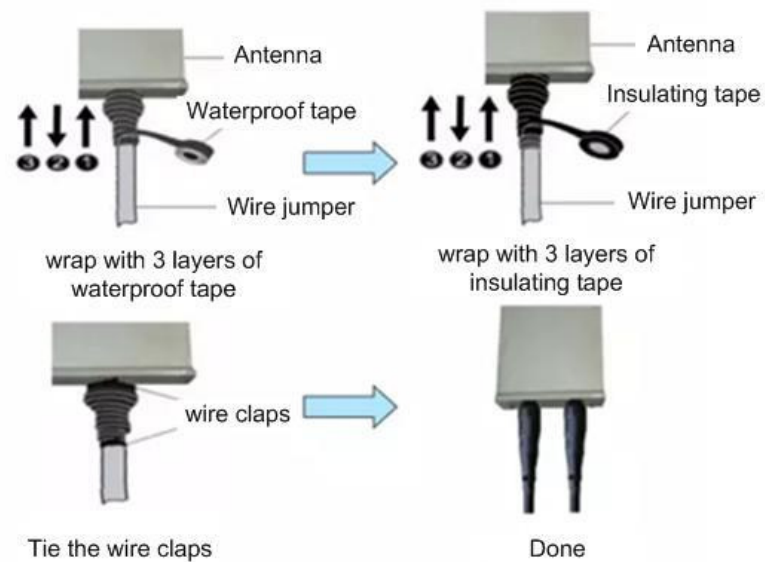

Be aware that at least three layers of tapes are needed, and make sure that the wrapping direction of the last layer is from the bottom up. The last layer should be in suitable tightness to keep it from cracking and also for good looking. The overall appearance after the waterproof processing is shown in Figure 3-13.

Figure 3-13 Antenna Waterproof Protection



3.2.3.4 Ground Protection

The grounding terminal is a screw beside the feeder interface, as shown in Figure 3-14. One end of the ground wire connects to the grounding terminal of base station, the other end connects to the outdoor ground point. The connection need to be tin-soldered.

Figure 3-14 Grounding Protection

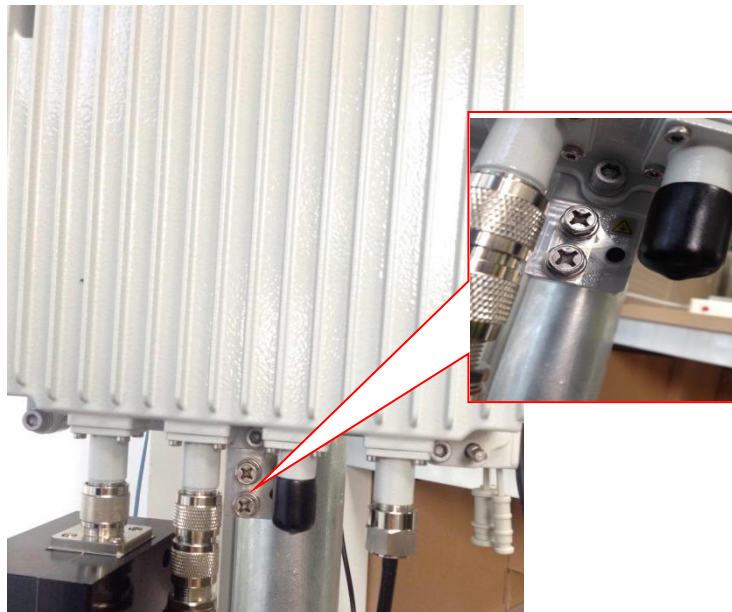

Note about grounding as follows:

-
- Ground wire adopts yellow-green wire that is no smaller than 16 mm².
 - Grounding principle: as near as possible.
 - The connection of ground terminals and ground bar is need to be tightness and reliable. And the rustproof processing is needed, such as rust preventing paint, anti-oxidation coatings, grease, and so on.

3.2.4 (Optional) Install GPS Antenna

Installation requirements on GPS antenna:

- GPS antenna must be installed vertically.
- To avoid the influence of reflected wave, GPS antenna should keep away from surrounding metal objects more than 1.5 meters.
- No major blocking from buildings in the vicinity. Keep the rooftop buildings a distance away from the GPS. Make sure the space atop within 90 degrees (at least 45 degrees in the south) is not blocked by any buildings.
- Avoid installing the GPS in the vicinity of any other transmitting and receiving devices. Avoid interference from other transmitting antennas to the GPS antennas.
- Should be installed within 45 degrees to the lightning rod.
- Mounting bracket and pole of GPS antenna must be grounding well.
- Multiple GPS antenna installs at a distance of 2 meters above.

GPS antenna installation steps as follows:

1. Prepare items for the GPS antenna installation, as shown in Figure 3-15.

Figure 3-15 GPS Antenna Parts



- The recommendation type of GPS antenna is LMR 400 GPS antenna feeder.
- GPS working frequency band is L1: 1575.42MHz ± 1.023MHz.

-
- GPS antenna feeder connector is N type.
2. Pass one end of GPS antenna feeder through the support tube, connect it to the N type of GPS antenna, and then fasten the support tube on the GPS antenna.
 3. Fix the support tube on the pole.
 4. Fix the lower end of cable and support tube with ribbon or tape.
 5. Fix cable on the pole, as shown in Figure 3-16.

Figure 3-16 GPS Pole Installation

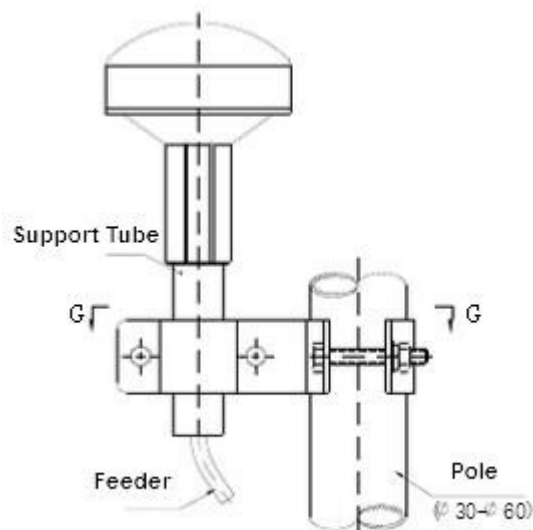

6. To avoid the connector getting loose causing by cable waggle, fix the cable on pole. The cable and the pole should be fixed reserving a certain margin (10 cm or more), preventing cable shrink due to temperature reduction in winter, as shown in Figure 3-17.

Figure 3-17 GPS Cable Fixing

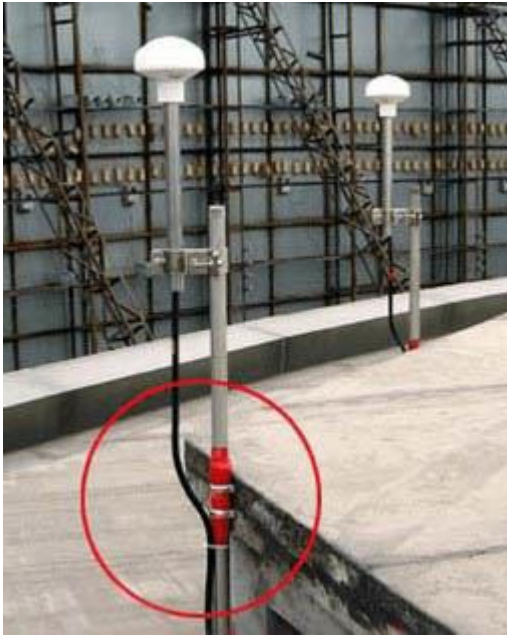

GPS antenna feeder should as short as possible to reduce the signal attenuation.

7. GPS connector connect to the base station, as shown in Figure 3-18.

Figure 3-18 GPS Connector Connect to Base Station



8. Waterproofing measures need to be taken on GPS connector and GPS antenna connector, using the waterproof daub and waterproof tape, refer to 3.2.3.3 Waterproof Protection.

3.3 Connection Wire

1. Connect antenna feeder.

Connect two antenna feeders to ANT1 and ANT2 interface, connect GPS antenna feeder to GPS interface, the interfaces of the BRU3510 base station as shown in Figure 3-19.

Figure 3-19 Connect Antenna Feeder

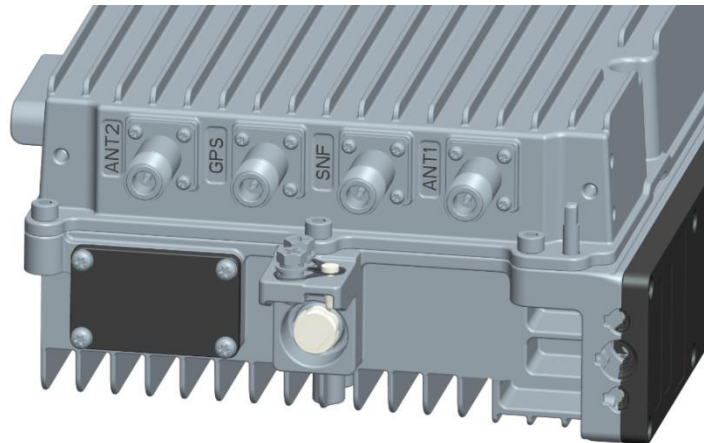

2. Connect Ethernet cable.

Connect Ethernet cable to ETH0 interface of the base station, fix the cable on ETH0, and fasten the screw, as shown in Figure 3-20.

Figure 3-20 Connect Ethernet Cable

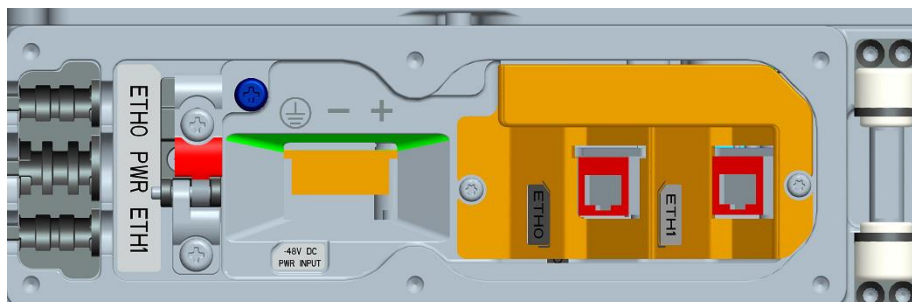

3. Connect power cable.

Connect 48V DC power connector to PWR interface of base station, as shown in Figure 3-21.

Figure 3-21 Connect Power Cable

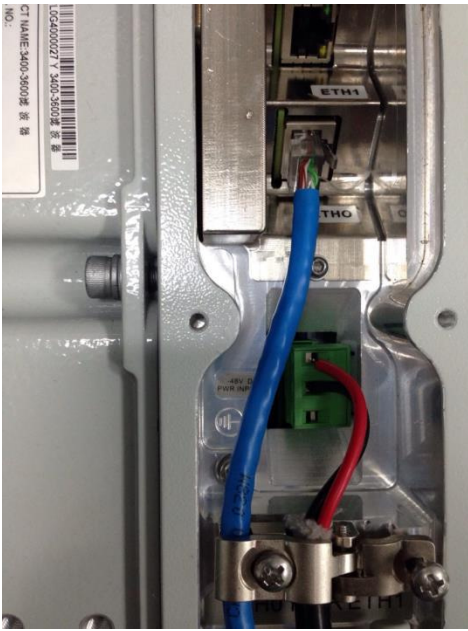

3.4 Power On

Power on the BRU3510, and the indicators will light up, as shown in Figure 3-22.

Figure 3-22 LED Indicator



The explanation of the indicator signal is given in Table 3-1.

Table 3-1 BRU3510 Indicator Description

Type	Color	Status	Meaning
PWR	Green	ON	Have power input
		OFF	No power input

RUN	Green	Fast blink: 0.125s on, 0.125s off	Single board loading
		Slow blink: 1s on, 1s OFF	Single board running well
		OFF	No power input, or single board failure
ALM	Red	ON	Hardware warning status, e.g., cable connection failure warning
		OFF	No warning
ACT	Green	ON	Active cell
		OFF	Inactive cell

3.5 Antennas Information

Following is the list of antennas certified for use. Customers can choose according to use environment of different antenna.

The antenna list is given in Table 3-2

Table 3-2 BRU3510 Antenna List

Antenna Type	Manufacturer	Model Number	Antenna Max Gain(dBi)
External Planar Antenna Dual Pole	Baicells Technologies Co., Ltd	ANT-2G17-R-65-EDT0	17
External Planar Antenna Dual Pole	Baicells Technologies Co., Ltd	ANT-2G15-R-65-EDT0	15
External Planar Antenna Dual Pole	Baicells Technologies Co., Ltd	ANT-2G13-R-65-EDT0	13
External Omnidirectional Antenna Single Pole	Baicells Technologies Co., Ltd	ANT-2G12-R-65-EDT0	10
External Omnidirectional Antenna Single Pole	Baicells Technologies Co., Ltd	ANT-2G10-R-65-EDT0	8
External Omnidirectional Antenna Single Pole	Baicells Technologies Co., Ltd	ANT-2G8-R-65-EDT0	6
External Omnidirectional Antenna Single Pole	Baicells Technologies Co., Ltd	ANT-2G0-R-65-EDT0	0

3.6 Regulatory Compliance

FCC Compliance

This device complies with part 15 of the FCC Rules. Operation is subject to the following two conditions: (1) This device may not cause harmful interference, and (2) this device must accept any interference received, including interference that may cause undesired operation.

Any Changes or modifications not expressly approved by the party responsible for compliance could void the user's authority to operate the equipment.

This equipment has been tested and found to comply with the limits for a Class A digital device, pursuant to part 15 of the FCC Rules. These limits are designed to provide reasonable protection against harmful interference when the equipment is operated in a commercial environment. This equipment generates, uses, and can radiate radio frequency energy and, if not installed and used in accordance with the instruction manual, may cause harmful interference to radio communications. Operation of this equipment in a residential area is likely to cause harmful interference in which case the user will be required to correct the interference at his own expense.

Warning

This equipment complies with FCC radiation exposure limits set forth for an uncontrolled environment. This equipment should be installed and operated with minimum distance 4 m between the radiator & your body.

IC Compliance

This device complies with Industry Canada licence-exempt RSS standard(s).

Operation is subject to the following two conditions: (1) This device may not cause interference, and (2) This device must accept any interference, including interference that may cause undesired operation of the device.

Le présent appareil est conforme aux CNR d'Industrie Canada applicables aux appareils radio exempts de licence. L'exploitation est autorisée aux deux conditions suivantes:

- (1) l'appareil ne doit pas produire de brouillage, et
- (2) l'utilisateur de l'appareil doit accepter tout brouillage radioélectrique subi, même si le brouillage est susceptible d'en compromettre le fonctionnement.

The antenna(s) used for this transmitter must be installed to provide a separation distance of at least 4 m from all persons and must not be collocated or operating in conjunction with any other antenna or transmitter, End-Users must be provided with transmitter operation conditions for satisfying RF exposure compliance.