



***Tier 2/3 Towable Generators
(Trailer and Skid Mounted)***

(Diesel Liquid Cooled)

TS25, 35, 45, 60, 80, 130, 175, 250 and 400

Installation & Operating Manual

**WARNING:
CALIFORNIA PROPOSITION 65 WARNING:**

Engine exhaust from this product contains chemicals known to the state of California to cause cancer, birth defects and other reproductive harm.

**WARNING:
CALIFORNIA PROPOSITION 65 WARNING:**

Battery posts, terminals and related accessories are known to the state of California to cause cancer, birth defects and other reproductive harm.

Table of Contents

Section 1	
Product Safety Information	1-1
Safety Notice	1-1
Responsibility	1-1
IMPORTANT SAFETY INSTRUCTIONS	1-2
Caution Statements	1-6
Section 2	
General Information	2-1
Section 3	
Receiving & Installation	3-1
Receiving & Inspection	3-1
Lifting the Generator	3-1
Physical Location	3-1
Secure the Generator	3-2
Hot Exhaust Gasses	3-3
Installation	3-3
Fuel Connections	3-3
Electrical Connections	3-4
Battery Connections	3-7
Recommended Engine Oil and Battery Type	3-9
Post Installation Checks	3-9
Section 4	
Operation	4-1
Towing the Generator	4-1
Selecting the Proper Towing Equipment	4-1
Safe Driving Tips	4-2
Safety Checks	4-3
Towing Instructions	4-4
Lug Nut Tightness	4-4
Trailer Setup	4-5
Voltage Selection	4-5
Pre-Start Procedure	4-8
Operating Procedures	4-8
Digital Engine Controller Description	4-9
Alarms	4-12
Inputs and Outputs	4-13
Analog Inputs	4-16
Setpoints	4-16
Section 5	
Troubleshooting and Maintenance	5-1
Maintenance	5-1
Problems and Solutions	5-2
Appendix A	
Wiring Diagrams	A-1
Wiring Diagrams	A-1

Section 1

Product Safety Information

Safety Notice

Be sure that you are completely familiar with the safe operation of this equipment. This equipment may be connected to other machines that have rotating parts or parts that are controlled by this equipment. Improper use can cause serious or fatal injury. Always disconnect all electrical loads before starting the generator.

Installation and repair procedures require specialized skills with electrical generating equipment and liquid cooled engine systems. Any person that installs or repairs this generator must have these specialized skills to ensure that this generating unit is safe to operate. Seek expert advise for repairs or any questions you may have about the safe installation and operation.

The precaution statements are general guidelines for the safe use and operation of this generator. It is not practical to list all unsafe conditions. Therefore, if you use a procedure that is not recommended in this manual you must determine if it is safe for the operator and all personnel in the proximity to the generator and connected loads. If there is any question of the safety of a procedure please seek expert advise before starting or stopping the generator.

This equipment contains high voltages. Electrical shock can cause serious or fatal injury. Only qualified personnel should attempt the start-up procedure or troubleshoot this equipment.

This equipment may be connected to other machines that have rotating parts or parts that are driven by this equipment. Improper use can cause serious or fatal injury. Only qualified personnel should attempt the start-up procedure or troubleshoot this equipment.

- System documentation must be available to anyone that operates this equipment at all times.
- Keep non-qualified personnel at a safe distance from this equipment.
- Only qualified personnel familiar with the safe installation, operation and maintenance of this device should attempt start-up or operating procedures.
- Always stop engine before making or removing any connections.
- Always stop engine and allow it to cool before refueling.

Responsibility



When your generator is delivered, it becomes the responsibility of the owner/operator of the generator set to prevent unsafe conditions and operation of the equipment. Some responsibilities include (but are not limited to) the following:

1. It is the responsibility of the owner/operator of this generator to ensure that this equipment is correctly and safely installed.
2. It is the responsibility of the owner/operator of this generator to ensure that this equipment, when installed fully complies with all federal, state and local codes.
3. It is the responsibility of the owner/operator of this generator to ensure that any person operating this equipment has been properly trained.
4. It is the responsibility of the owner/operator of this generator to ensure that any person operating this equipment has access to all manuals and information required for the safe use and operation of this equipment.
5. It is the responsibility of the owner/operator of this generator to ensure that it is properly maintained and safety inspected at regular scheduled intervals.
6. It is the responsibility of the owner/operator of this generator to ensure that any person who has not been trained on the safe use of this equipment does not have access to this equipment.

Read This Manual Thoroughly

If you do not understand any concept, any procedure, any safety warning statement, any safety caution statement or any portion of this manual, seek expert advise. Make sure you understand the information in this manual so that you can safely enjoy the full use of this generator.

Symbols

-  This symbol is shown throughout the manual to indicate a connection to ground reference point.
-  Indicates a potentially hazardous situation which, if not avoided, could result in injury or death.
-  Indicates a potentially hazardous situation which, if not avoided, could result in injury or death.

Precaution Statements Used In This Manual

There are three classifications of precautionary statements used in this manual. The most critical is a **WARNING** statement, then the **Caution** statement and the least critical is the Note statement. The usage of each statement is as follows:

- WARNING:** Indicates a potentially hazardous situation which, if not avoided, could result in injury or death.
- Caution:** Indicates a potentially hazardous situation which, if not avoided, could result in damage to property.
- Note:** Additional information that is not critical to the installation or operation.

IMPORTANT SAFETY INSTRUCTIONS

SAVE THESE INSTRUCTIONS – This manual contains important instructions for the generator that should be followed during installation, operation and maintenance of the generator.

For ease of reading, the Warning statements are divided into four categories: Operation, Burn, Installation, and Maintenance.

Operation

- WARNING:** Never allow a person to ride in or on a trailer that is being towed. All states prohibit passengers in towed vehicles. A person can fall off and be struck by another vehicle or run over by the towed trailer. Failure to observe this warning can result in death.
- WARNING:** Before using a tow vehicle with a trailer mounted generator, verify that the vehicle is designed for the load. Using a vehicle that is too small is very dangerous. Be certain that it can handle the M.G.T.W. (Maximum Gross Trailer Weight) and the tongue weight for safe towing and braking.
- WARNING:** For a new trailer, the wheel lug nuts should be tightened to the proper torque specification before use, after 25 miles of operation and every 100 miles of operation thereafter. Failure to check the lug nuts for proper tightness can result in an accident due to a wheel falling from the trailer.
- WARNING:** Never operate a trailer or tow vehicle that has a loose, missing or broken lug nut. The trailer is designed for safe operation with all lug nuts installed and all at the proper torque rating. Operating the trailer with one or more broken or missing lug nuts greatly increases the load on the remaining nuts and can cause failure of the remaining nuts that can result in an accident due to a wheel falling from the trailer.
- WARNING:** Never operate this generator in a manner other than as described in this manual. Operation in any manner not described in this manual should be considered unsafe and should not be attempted. Never start the engine unless you have first verified that the installation and operation of the generator are as described in this manual.
- WARNING:** Be sure that you are completely familiar with the safe operation of this equipment. This equipment may be connected to other machines that have rotating parts or parts that are controlled by this equipment. Improper use can cause serious or fatal injury.
- WARNING:** Exhaust fumes/gases are extremely dangerous and can cause severe illness or death. Never breathe exhaust fumes produced by a running engine. Only run the engine outdoors where ventilation is plentiful. Exhaust gases contain carbon monoxide, a colorless, odorless and extremely dangerous gas that can cause unconsciousness or death. Symptoms of carbon monoxide poisoning include: dizziness, nausea, headaches, sleepiness, vomiting or incoherence. If you or anyone else experiences these symptoms, get out into fresh air immediately. Stop the engine and do not restart the engine until it has been inspected and if necessary repaired or reinstalled in a well ventilated area.
- WARNING:** When operating this generator remain alert at all times. Never operate machinery when physically or mentally fatigued, or while under the influence of alcohol, drugs or medication.

Continued on next page.

Operation Warning Statements Continued

- WARNING:** Over crank indication can mean a loss of crank disconnect signal during the previous run period. Attempting to restart the engine with no crank disconnect signal can destroy the starter motor, which can cause serious personal injury.
- WARNING:** Hot exhaust gasses must never be directed toward anything that may catch fire or explode.
- WARNING:** This generator must not be used on or near any forest covered, brush covered, or grass covered land unless the engine's exhaust system is equipped with a spark arrestor. The spark arrestor must be maintained in effective working order by the operator.
- WARNING:** Never operate the generator set indoors or in a poorly ventilated area such as a tunnel or cave. Exhaust fumes are extremely dangerous to all personnel that are in or in contact with that area.
- WARNING:** Keep generator at least three feet away from buildings and other structures.
- WARNING:** Keep generator away from flammable or hazardous materials (trash, rags, lubricants, explosives, paints etc.) and grass or leaf build up.
- WARNING:** Some parts of this generator rotate during operation. Rotating parts can present extreme danger if clothing or body extremities are caught by the rotating part and can cause serious or fatal injury. Never touch a part of the generator until the engine has been stopped and all rotating parts are completely stopped. Also, disconnect the battery terminals to prevent accidental engine rotation during servicing.
- WARNING:** Never move a generator set that is running. Loads should be connected and position secure before starting the engine. Hazards are caused by moving a generator set that is running.
- WARNING:** Never connect or disconnect loads during operation. Always connect load circuits before starting the engine and use external branch disconnects etc. to switch loads On/Off.
- WARNING:** High voltage is present whenever engine is running. Electrical shock can cause serious or fatal injury. Never operate electrical equipment while standing in water, on wet ground or with wet hands, feet or shoes or while barefoot.
- WARNING:** High voltage is present whenever the engine is running. Electrical shock can cause serious or fatal injury. Always stop engine before connecting or disconnecting power cords or external devices.
- WARNING:** Be sure that you understand how to stop the engine quickly in case of an emergency situation. Become familiar with the controls and safety systems provided with this generator set.
- WARNING:** Always wear safety glasses with side shields and hearing protection when working near the generator.
- WARNING:** Improper operation may cause violent motion of connected equipment. Be certain that unexpected movement will not cause injury to personnel or damage to equipment.
- WARNING:** Never permit anyone to operate the generator without proper instructions. Be sure to keep a copy of this manual with the generator so that all users can be properly informed of its safe operation.
- WARNING:** Never allow children or pets to be in the area where the generator is running. The generator and the equipment being powered by the generator may cause injury or death.
- WARNING:** Never operate the generator unless all guards, covers, shields and other safety items are properly installed.
- WARNING:** Do not put hands, feet, tools clothing or other objects near rotating parts such as drive shaft, pulley, belt etc. Rotating parts cause extremely dangerous situations because they can catch loose clothing or extremities and cause serious or fatal injury.
- WARNING:** Never operate the engine when the air cleaner is removed. An engine backfire can cause serious burns.
- WARNING:** Never "jump start" a generator to start the engine. If the battery charge is insufficient to start the engine, charge or replace the battery and try to restart. Jump starting a battery can cause the battery to explode and cause severe injury or death to anyone in the area.
- WARNING:** Do not smoke near generator during operation or when close to fuel source. LPG and natural gas fuels are flammable and can cause fire, explosions, injury or death.
- WARNING:** Keep a fire extinguisher near the generator while generator is in use. An extinguisher rated "ABC" by the National Fire Protection Association is appropriate.

Continued on next page.

Warning Statements Continued

Burn

- WARNING:** Parts of this generator are extremely hot during and after operation. To prevent severe burns, do not touch any part of the generator until you have first determined if the part is hot. Wear protective clothing and after use allow sufficient time for parts to cool before touching any part of the generator.
- WARNING:** Do not touch the hot exhaust parts. In addition to a severe burn, the sudden involuntary jerk of the hand or body part caused by contact with high voltage or a hot surface can result in injury to yourself or others.
- WARNING:** Engine coolant is under pressure and is near the boiling point of water when engine is hot. Do not open the coolant system until the engine has completely cooled. Hot coolant can cause severe burns and other injuries. When engine is cool, coolant level can be checked.

Installation

- WARNING:** Disconnect the battery's ground terminal before working in the vicinity of the battery or battery wires. Contact with the battery can result in electrical shock when a tool accidentally touches the positive battery terminal or wire. The risk of such shock is reduced when the ground lead is removed during installation and maintenance.
- WARNING:** Installation and repair procedures requires specialized skills with electrical generating equipment and small engine systems. Any person that installs or performs repairs must have these specialized skills to ensure that the generator set is safe to operate. Seek expert advise for installation or repairs.
- WARNING:** Be sure all wiring complies with the National Electrical Code (NEC) and all regional and local codes or CE Compliance. Improper wiring may cause a hazardous condition and exposure to electrical hazards can cause serious injury or death.
- WARNING:** Be sure the system is properly grounded before applying power. Do not apply AC power before you ensure that grounds are connected. Electrical shock can cause serious or fatal injury. NEC requires that the frame and exposed conductive surfaces (metal parts) be connected to an approved earth ground. Local codes may also require proper grounding of generator systems.
- WARNING:** Place protective covers over all rotating parts such as drive shaft, pulley, belt etc. Rotating parts cause extremely dangerous situations because they can catch loose clothing or extremities and cause serious or fatal injury.
- WARNING:** Unauthorized modification of a generator set may make the unit unsafe for operation or may impair the operation of the unit. Never start a generator set that has been modified or tampered with. Be sure that all covers and guards are properly installed and that the unit is safe before starting the engine. If you are unsure, seek expert advise before starting the engine.
- WARNING:** When moving the generator, use reasonable caution. Be careful where you place fingers and toes to prevent injury "Pinch Points". Never try to lift a generator without a hoist or lift means because they are heavy and bodily injury may result.
- Warning:** Never connect this generator to the electrical system of any building unless a licensed electrician has installed an approved transfer switch. The national electrical code (NEC) requires that connection of a generator to any electrical circuit normally powered by means of an electric utility must be connected by means of approved transfer switch equipment to isolate the electrical circuit from the utility distribution system when the generator is operating. Failure to isolate the electrical circuits by such means may result in injury or death to utility power workers due to backfeed of electrical energy onto the utility lines.
- WARNING:** Circuit overload protection must be provided in accordance with the National Electrical Code and local regulations.
- WARNING:** Check Ground Fault Circuit Interrupt (GFCI) receptacles monthly by using the "Test" and "Reset" buttons.
- WARNING:** Only a professional experienced technician should install a fuel supply system. Diesel, LPG and natural gas fuels are flammable and can cause fire, explosions, injury or death. Fuel supply lines should be kept away from sharp objects to prevent rupture. Comply with all NFPA regulations and local codes for shut-off valves, regulators, fuel line type, connectors etc.
- WARNING:** Have electrical circuits and wiring installed and checked by licensed electrician or qualified technician. Electrical shock can cause serious or fatal injury.

Continued on next page.

Warning Statements Continued

WARNING: Incorrect installation of this generator set could result in property damage, injury or death. Connection of the generator to its fuel source must be done by a qualified professional technician or contractor.

WARNING: Never stand under or close to an object that is being hoisted or lift into position. Accidents happen and if the object falls or tips over you or someone else could be crushed by the weight of the object causing severe injury or death to to yourself or others. Always remain a safe distance from the object and always wear protective head gear (hard hat).

Maintenance

WARNING: Before servicing the generator set, be sure to disconnect the battery terminals to prevent accidental engine rotation or starting.

WARNING: Before cleaning, inspecting, repairing or performing any maintenance to the generator set, always be sure the engine has stopped and that all rotating parts have also stopped. After stopping, certain components are still extremely hot so be careful not to get burned.

WARNING: Before servicing the generator set, be sure to disconnect the glow plugs or spark plug wires and the battery terminals to prevent accidental engine rotation or starting.

WARNING: Engine coolant is under pressure and is near the boiling point of water when engine is hot. Do not open the coolant system until the engine has completely cooled. Hot coolant can cause severe burns and other injuries. When engine is cool, coolant level can be checked.

WARNING: Inspect all wiring frequently and replace any damaged, broken or frayed wiring or wires with damaged insulation immediately. Electrical shock can cause serious or fatal injury.

WARNING: Disconnect all electrical wires and load devices from generator power outlets before servicing the generator. Electrical shock can cause serious or fatal injury. Always treat electrical circuits as if they are energized.

WARNING: Check all fuel supply piping, and their connections monthly for fuel leaks. Diesel, LPG and natural gas fuels are flammable and can cause fire, explosions, injury or death. If a leak is found, replace only with approved pipe or components.

WARNING: A battery presents a risk of fire and explosion because they generate hydrogen gas. Hydrogen gas is extremely explosive. Never jump start a battery, smoke in the area around the battery or cause any spark to occur in the area around the battery.

WARNING: Do not mutilate the battery or dispose of a battery in a fire. The battery is capable of exploding. If the battery explodes, electrolyte solution will be released in all directions. Battery electrolyte solution is caustic and can cause severe burns and blindness. If electrolyte contacts skin or eyes, immediately flush the area with water and seek medical attention quickly.

WARNING: The battery electrolyte is a dilute sulfuric acid that is harmful to the skin and eyes. It is electrically conductive and corrosive. If electrolyte contacts the skin, flush the area immediately with water and wash it off using soap and water. If electrolyte contacts the eyes, immediately flush the eye thoroughly with water and seek medical attention quickly.

WARNING: A battery presents a risk of electrical shock hazard and high short circuit current. Electrical shock can cause serious or fatal injury. Never wear jewelry, watch or any metal objects when in the area around the battery.

Continued on next page.

Caution Statements

- Caution:** Avoid installing the generator set beside heat generating equipment, or directly below water or steam pipes or in the vicinity of corrosive substances or vapors, metal particles and dust. Heat can cause engine problems to develop and unwanted substances can cause rust or generator failure over time.
- Caution:** Do not apply high voltage to windings (do not start the generator) in a moisture-saturated condition. Moisture can cause insulation breakdown, making it necessary to repair the generator and consequent expense and loss of time.
- Caution:** Use only original equipment or authorized replacement parts. Using the correct parts will assure continued safe operation as designed.
- Caution:** Do not support the generator from the top of the frame or enclosure.
- Caution:** Do not tamper with or change the engine speed. Engine speed is factory set to produce the correct voltage and output frequency.
- Caution:** Never operate the engine without a muffler. The engine is designed to have the correct exhaust components installed and operating without these components can present a fire hazard, cause excessive exhaust gases and cause damage to engine. Inspect muffler periodically and replace if necessary.
- Caution:** The Programmable Output Contacts selection must agree with the external control wiring prior to energizing the controller. Failure to do so may cause severe equipment damage.
- Caution:** If a dead battery is suspected, remove the controller fuse, charge battery (or replace), and then attempting starting. Damage to engine control may result from jump starting.
- Caution:** This generator must have a battery installed for operation. The battery is used during starting and during operation. If engine operation is attempted while the battery is removed, damage to the engine's electrical components may result.
- Caution:** Large "Engine Compartment Doors" on each side of enclosure must remain closed during operation. If doors remain open, engine will overheat due to insufficient air flow around engine.

Section 2 General Information

Thank you for purchasing your Baldor Generator Set. This manual contains information you need to safely and efficiently install and operate your generator set. During the preparation of this manual every effort was made to ensure the accuracy of its contents. This manual describes only very basic engine information. A separate owner's manual for the engine is supplied with this unit for your use. Please refer to the engine manual for information relative to engine operation, maintenance, recommendations and additional safety warnings.

Copyright Baldor © 2006. All rights reserved.

This manual is copyrighted and all rights are reserved. This document may not, in whole or in part, be copied or reproduced in any form without the prior written consent of Baldor Electric Company, Inc.

Baldor Generators have earned the reputation of being high quality and dependable. We take pride in this fact and continue to keep our quality standards high on our list of priorities. We are also constantly researching new technological ideas to determine if they could be used to make our generator sets even better.

Baldor makes no representations or warranties with respect to the contents hereof and specifically disclaims any implied warranties of fitness for any particular purpose. The information in this document is subject to change without notice. Baldor assumes no responsibility for any errors that may appear in this document.

Limited Warranty

Baldor will replace or repair free of charge any part or parts of the generator of their manufacture that are defective in workmanship and materials for a period of time as set forth in the Warranty Period chart below. All Baldor products requiring warranty service shall be transported or shipped freight pre-paid to a Baldor Generator repair facility. Notification of the defect or problem, a description of the manner in which the Baldor generator is used, and the name, address and telephone number of the customer requiring warranty service must be included. Baldor is not responsible for removal and shipment of the Baldor product to the service center or for the reinstallation of the Baldor product upon its return to the customer, or any incidental or consequential damages resulting from the defect, removal, reinstallation, shipment or otherwise. Problems with Baldor products can be due to improper maintenance, faulty installation, non-Baldor additions or modifications, or other problems not due to defects in Baldor workmanship or materials. If a Baldor Generator repair facility determines that the problem with a Baldor product is not due to defects in Baldor workmanship or materials, then the customer will be responsible for the cost of any necessary repairs. Genset engines are covered under the engine manufacturers warranty. Proper engine maintenance is required. Any request for engine warranty or repair should be made directly with the engine manufacturers warranty center. See engine manufacturers data for applicable engine warranty periods and location of repair centers. This Limited Warranty and Service Policy represents Baldor's sole and exclusive warranty obligation with respect to Baldor products. Baldor's liability to a customer or any other person shall not exceed Baldor's sales price of the applicable Baldor product. **BALDOR DISCLAIMS ALL OTHER EXPRESSED AND IMPLIED WARRANTIES INCLUDING THE IMPLIED WARRANTIES OF FITNESS FOR A PARTICULAR PURPOSE AND MERCHANTABILITY.**

Warranty Period

Generator Series	Labor*	Parts
Portable Products (Premier, Powerchief, DG Series)	1 Year	3 Years
Towable Products (TS)	1 Year or 3,000 Hours	3 Years or 3,000 Hours
POW'R LITE Light Towers	1 Year or 3,000 Hours	3 Years or 3,000 Hours Light Fixture, Lamps and Ballasts are excluded from any warranty coverage
3600 RPM Standby Systems (Some AE Models)	1 Year or 1,000 Hours	3 Years or 1,000 Hours
1800 RPM Standby Systems (Some AE Models, DLC, GLC)	1 Year or 3,000 Hours	3 Years or 3,000 Hours
Industrial Standby Systems	1 Year or 1,000 Hours	2 Years or 1,000 Hours
Industrial Prime Power Systems	1 Year or 1,000 Hours	1 Year or 1,000 Hours
International	1 Year or 1,000 Hours	1 Year or 1,000 Hours

*For products covered under labor coverage, travel expenses will be allowed up to 7 hours straight labor or 300 miles, whichever occurs first, and only applies to permanently wired and mounted products (AE, DLC, GLC, IDLC).

You must save the purchase receipt. Proof of purchase, date, serial number and model number will be required for all portable and Towable products to qualify for any warranty consideration.

A start-up inspection form/warranty registration must be completed in its entirety and submitted to Baldor Generators within 30 days of start-up to qualify for any warranty consideration, excluding: Portables, Towables and Light Towers.

Section 3 Receiving & Installation

Receiving & Inspection When you receive your generator, there are several things you should do immediately.

1. Observe the condition of the shipping container and report any damage immediately to the commercial carrier that delivered your system.
2. Verify that the part number of the system you received is the same as the part number listed on your purchase order.
3. If the system is to be stored for several weeks before use, be sure that it is stored in a location that conforms to published storage temperature and humidity specifications.

WARNING: Never stand under or close to an object that is being hoisted or lift into position. Accidents happen and if the object falls or tips over you or someone else could be crushed by the weight of the object causing severe injury or death to to yourself or others. Always remain a safe distance from the object and always wear protective head gear (hard hat).

Lifting the Generator When lift or hoist equipment is used to lift the generator and move it to position, be careful not to contact overhead wires or other obstacles. Be sure the lift or hoist equipment has appropriate capacity and tires for the terrain to avoid becoming stuck or tipping over. If the shipping pallet is intact, use a fork lift to move the generator. If the shipping pallet has been removed, use the “Lift Point” hole at the top of the generator, Figure 3-1.

The lift point is designed only for the weight of the generator and factory trailer. Do not lift by these points if the generator is mounted to a trailer that has been modified from the factory specifications for stock units. Please consult Baldor for custom designs.

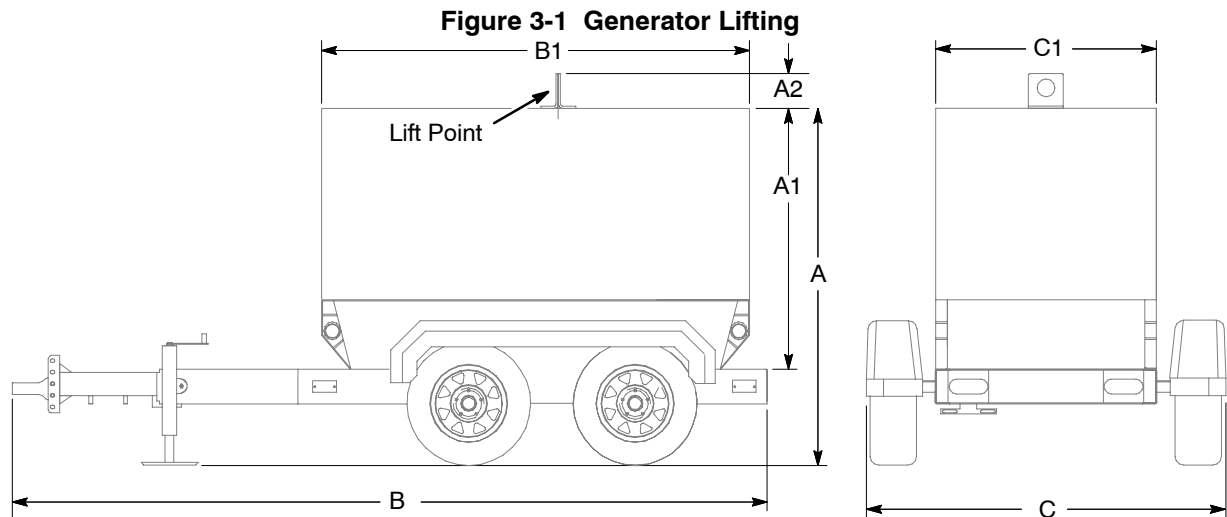

Table 3-1 Mounting Dimensions

Generator	No. of Axles	A	A1	A2	B	B1	C	C1
TS25	1	67	47.5	5.5	130	74	62	38
TS35	1	67	47.5	5.5	130	74	62	38
TS45	2	82	60	5.5	146	84	62	38
TS60	2	82	60	5.5	146	84	62	38
TS80	2	76	55	5.5	146	84	62	38
TS130	2	88	68	6	180	118	75	42
TS175	2	88	68	6	180	118	75	42
TS250	2	102	76	7	218	159	82	54
TS400	2	126	93	5.22	251	195	98	66

Physical Location The mounting location of the system is important. It should be installed in an area that is protected from direct harmful gases or liquids, dust, metallic particles, shock and vibration. It should be installed in an outdoor location so the exhaust fumes are vented to the atmosphere.

When the Generator is installed outdoors

The factory installed enclosure is designed to keep out undesirable weather elements while providing cooling and ventilation.

Several other factors should be carefully evaluated when selecting a location for installation:

1. For effective cooling and maintenance, the system should be mounted on a flat, smooth, noncombustible level surface. A concrete pad is ideal and provides a secure installation.
2. Installation should prevent water levels from reaching the generator. Drainage must be adequate to keep concrete pad free from standing water.
3. Installation should prevent obstructions by buildup of leaves, grass, sand, snow, etc. If these items pose a problem, consider building a small fence or other break to protect the unit from accumulation of debris.
4. Installation should place the generator as close as possible to the transfer switch.
5. At least forty-eight (48) inches clearance must be provided on all sides for air flow.
6. Access must be provided to allow the enclosure covers to be opened or removed for service and maintenance.
7. Maximum Ambient temperature is 122°F (50°C).

Figure 3-2 Generator Mounting (Skid)

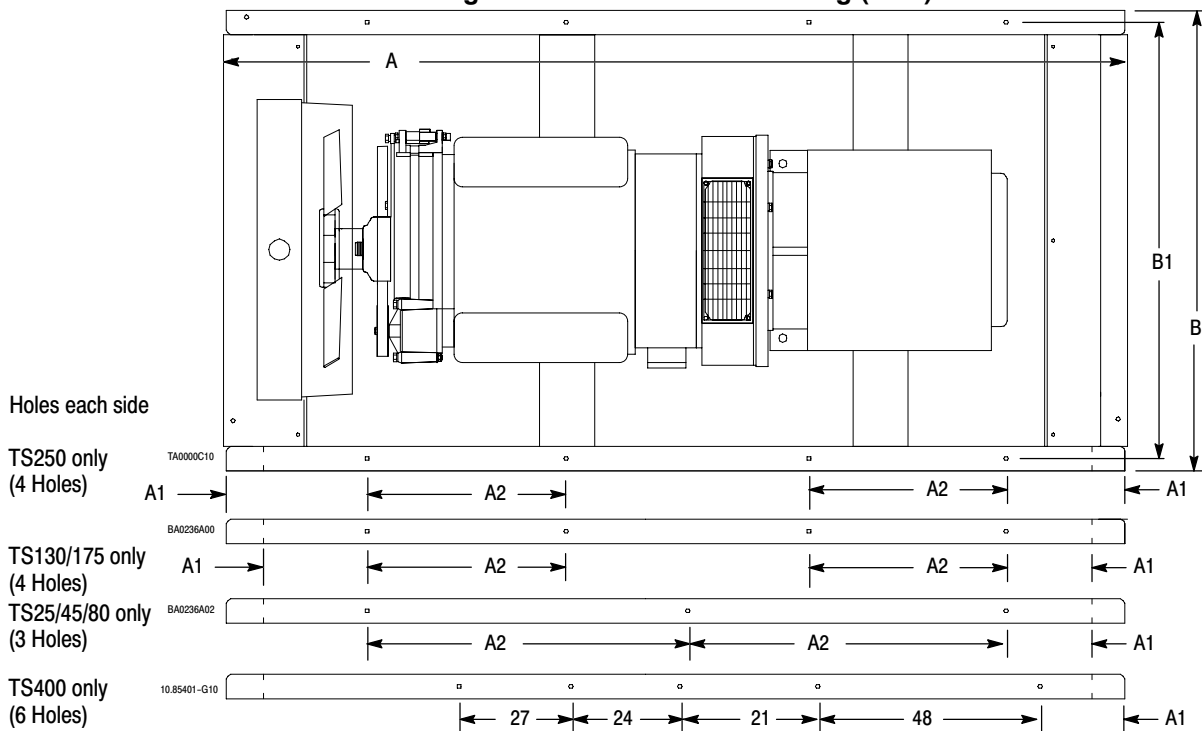

Table 3-2 Mounting Dimensions

Generator	A	A1	A2	B	B1
TS25	74	8.12	23.81	38	36
TS35	74	8.38	28.56	38	36
TS45	84	8.38	28.56	38	36
TS60	84	8.38	28.56	38	36
TS80	84	8.38	28.56	38	36
TS130	118	16.57	26.57	42	40
TS175	118	16.57	26.57	42	40
TS250	159	18.00	40.00	54	52
TS400	195	12.00	See Figure 3-2	66	63

Secure the Generator (Skid Mount only)

Six mounting bolts (eight for TS130/175/250) in the base frame secure the generator to the shipping pallet. Remove these bolts, lift the generator and remove the shipping pallet. Secure the generator to the concrete pad using anchor hardware (not provided) in the base frame mounting holes (holes are 0.66" diameter). See Figure 3-2 and Table 3-2. Anchor bolts must be long enough to extend through the generator mounting frame.

Hot Exhaust Gasses

WARNING: Exhaust fumes/gases are extremely dangerous and can cause severe illness or death. Never breath exhaust fumes produced by a running engine. Only run the engine outdoors where ventilation is plentiful. Exhaust gases contain carbon monoxide, a colorless, odorless and extremely dangerous gas that can cause unconsciousness or death. Symptoms of carbon monoxide poisoning include: dizziness, nausea, headaches, sleepiness, vomiting or incoherence. If you or anyone else experiences these symptoms, get out into fresh air immediately. Stop the engine and do not restart the engine until it has been inspected and if necessary repaired or reinstalled in a well ventilated area.

WARNING: Hot exhaust gasses must never be directed toward anything that may catch fire or explode.

Exhaust must always be directed away from living areas or buildings that are occupied by people or animals. Never allow exhaust gases to be directed towards any openings or air entry routes (doors, windows, vents, etc...) of an occupied building.

The direction of the discharged hot air and hot exhaust gases is important as they have the potential to create brown spots on the lawn or shrubs. In extreme cases this extremely hot air could cause dried grass, shrubs, trees or other debris to ignite.

It is also recommended that an exhaust rain cap be used whenever it is possible that rain could get into the system. This will help to prevent corrosion and damage to the exhaust system and engine.

Installation

The generator is completely assembled, tested and adjusted at the factory before it is shipped. The procedures presented in this manual are suggestions and it is the responsibility of the Owner/Operator to arrange for these procedures to be performed by licensed contractors according to all applicable codes including local codes for your Municipality/City/County and State. External connections required at the time of installation are:

1. Electrical Connections – power wiring (optional transfer switch) and control wiring.
2. Ground Connection.

After installation, the post installation checks must be performed prior to starting the engine.

After these checks have been performed and the system operation is verified to be good, refer to Section 5 Maintenance for periodic checks that must be performed at scheduled intervals to ensure continued operation with minimal problems.

WARNING: Disconnect the battery's ground terminal before working in the vicinity of the battery or battery wires. Contact with the battery can result in electrical shock when a tool accidentally touches the positive battery terminal or wire. The risk of such shock is reduced when the ground lead is removed during installation and maintenance.

Fuel Connections

External fuel connections are not required. A self contained fuel tank is located within the base of the generator set.

Electrical Connections Class 1 wiring methods must be used for field wiring connections to terminals of a class 2 circuit. It is the responsibility of the owner/operator to arrange for these procedures to be performed by a licensed electrical contractor and ensure conformance to all applicable codes including local codes peculiar to your municipality/city/county and state. Wire size and insulation type should be as required by NEC (National Electrical Code) and local codes.

Warning: **Never connect this generator to the electrical system of any building unless a licensed electrician has installed an approved transfer switch. The national electrical code (NEC) requires that connection of a generator to any electrical circuit normally powered by means of an electric utility must be connected by means of approved transfer switch equipment to isolate the electrical circuit from the utility distribution system when the generator is operating. Failure to isolate the electrical circuits by such means may result in injury or death to utility power workers due to backfeed of electrical energy onto the utility lines.**

Warning: **Incorrect installation of this generator set could result in property damage, injury or death. Connection of the generator to its fuel source must be done by a qualified professional technician or contractor.**

WARNING: **Be sure the system is properly grounded before applying power. Do not apply AC power before you ensure that grounds are connected. Electrical shock can cause serious or fatal injury. NEC requires that the frame and exposed conductive surfaces (metal parts) be connected to an approved earth ground. Local codes may also require proper grounding of generator systems.**

Intended Use The intended purpose of this generator set is to provide electrical power when the main utility power supply is interrupted. Therefore, it is important that all the wiring that connects the generator set with your house, transfer switch, distribution box, battery charger, etc. be properly installed.

Protection **Single Phase** circuit protection is provided within the generator. The power output connections are rated and sized according to the KW of the generator. Proper lead wire from these points to the automatic transfer switch (or load switching device) is mandatory. See transfer switch information for corresponding generator input terminals.

Three phase circuit protection is provided by the generator. When connecting the generator output to an electrical load, a UL listed circuit breaker with the appropriate ratings shall be provided within 25 feet of the Genset. Use only copper wires.

Table 3-3 Standby Power Ratings

Generator Catalog No.	Electrical Load Capacity Standby Power Ratings							
	1 Phase				3 Phase			
	kVA	kW	Volts	Amps *	kVA	kW	Volts	Amps
TS25	18	18	240/120	75/2x75	25/25/25	20/20/20	208/240/480	69/60/30
TS35	25	25	240/120	104/2x104	37/37/37	30/30/30	208/240/480	104/90/45
TS45	27	27	240/120	112/x2112	46/46/48	37/37/38	208/240/480	128/111/57
TS60	43	43	240/120	179/2x179	60/60/61	48/48/49	208/240/480	166/144/73
TS80	45	45	240/120	187/2x187	72/72/81	58/58/65	208/240/480	201/174/97
TS130	70	70	240/120	291/2x291	131/131/134	105/105/107	208/240/480	364/315/160
TS175	100	100	240/120	416/2x416	169/169/175	135/135/140	208/240/480	468/405/210
TS250	175	175	240/120	729/2x729	250/250/250	200/200/200	208/240/480	693/601/300
TS400	250	250	240/120	1041/2x1041	400/400/400	320/320/320	208/240/480	1110/962/481

* Example 2x75 means 2 lines (Line to Neutral) of 120V @ 75 amps each.

Table 3-4 Prime Power Ratings

Generator Catalog No.	Electrical Load Capacity Prime Power Ratings							
	1 Phase				3 Phase			
	kVA	kW	Volts	Amps *	kVA	kW	Volts	Amps
TS25	18	18	240/120	75/2x75	23/23/23	18/18/18	208/240/480	62/54/27
TS35	22	22	240/120	91/2x91	33/33/33	27/27/27	208/240/480	93/81/40
TS45	25	25	240/120	104/2x104	44/44/44	35/35/35	208/240/480	121/105/52
TS60	40	40	240/120	166/2x166	56/56/56	45/45/45	208/240/480	156/135/67
TS80	43	43	240/120	179/2x179	69/69/75	55/55/60	208/240/480	190/165/90
TS130	66	66	240/120	275/2x275	119/119/121	95/95/97	208/240/480	329/285/145
TS175	95	95	240/120	395/2x395	156/156/159	125/125/127	208/240/480	433/375/190
TS250	160	160	240/120	666/2x666	227/227/227	180/180/180	208/240/480	624/541/270
TS400	240	240	240/120	1000/2x1000	365/365/365	292/292/292	208/240/480	1013/878/439

* Example 2x75 means 2 lines (Line to Neutral) of 75 amps each.

Single Phase Connections

Single phase connections are made at load receptacles located by the operator panel, see Figure 3-3. Simply open the rear panel access door and make the connections. When the panel door is closed, the connections are weather tight.

Figure 3-3 Receptacle Panel (Single Phase)

Single phase power is always available.



Single pole breaker
for 120VAC outlets



Double pole breaker
for 240VAC outlets

Circuit Breakers (Single or Double pole)

Circuit Breakers provides protection on some units. To reset a breaker, place it in the OFF then the ON position.

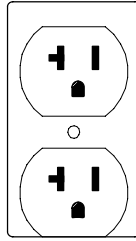

STD Outlet
120V, 20A

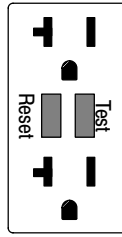

GFI Outlet
120V, 20A

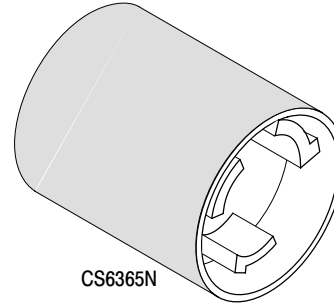

CS6365N

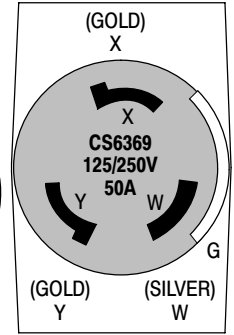

240V, 50A

Three Phase Connections

Three phase connections are made at L1, L2, L3 and N connections shown in Figure 3-4.

Figure 3-4 Three Phase and Remote Start Connections

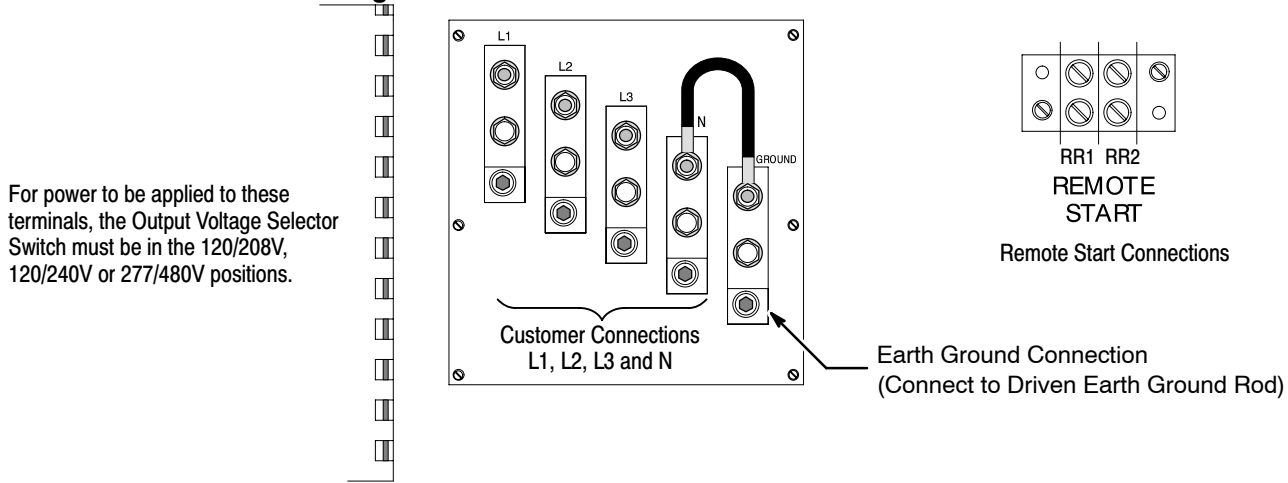

Transfer Switch Considerations

The following are general considerations for the safe use of a transfer switch:

1. The transfer switch should be located inside the building near the main breaker box or the disconnect box.
2. The transfer switch must be kept away from any location that might allow water to get on it.
3. If the transfer switch is mounted outside, it must be protected from the environment and its elements.
4. Do not mount the transfer switch on the generator set.
5. Do not mount the transfer switch where flammable liquids or vapors are present.

Remote Start Contacts

This two-wire connection will start and stop the generator, when properly connected to a remote start contact, shown in Figure 3-4. These contacts RR1 and RR2 are connected to the "Engine Start Contacts" of the automatic transfer switch. A two pole normally open, closed to operate switch may also be used to start the generator.

Shore Power Use extension cord with appropriately sized conductors to connect the optional "Shore Power" receptacle to 120VAC (240VAC for TS400) single phase utility power. This powers battery chargers, block heaters etc. when the generator is not in operation. A single phase 20 amp breaker is provided for circuit protection.

AC Input These connections are for units with float type battery charger or engine block heater. A constant supply of 120 volts AC (or as specified) is needed at these terminals to power these devices when generator is not operating.

Note: Power is not required when the unit is in operation. Internal battery charging and radiant heat during operation eliminate the need for these devices.

Battery Charger Considerations

1. Mount the battery charger inside the generator enclosure as close to the battery as is reasonably possible.
2. Do not mount the battery charger where flammable liquids or vapors are present. When the battery is charging it produces explosive gasses.

General Wiring Considerations

1. When routing the interface wiring, do not route it up against anything that could cut or chafe the wiring. do not route the wire up against any hot or potentially hot object.
2. Make sure that all the electrical components (generator set, transfer switch, battery charger, etc.) share a common ground.
3. Check with your local building inspector to determine what you must do to comply with the local regulations for grounding of this type of permanent installation.

Frame Ground Connection

WARNING: Be sure the system is properly grounded before applying power. Do not apply AC power before you ensure that grounds are connected. Electrical shock can cause serious or fatal injury. NEC requires that the frame and exposed conductive surfaces (metal parts) be connected to an approved earth ground. Local codes may also require proper grounding of generator systems.

It is important for safety reasons that the Generator set, transfer switch and battery charger share a common Ground and neutral.

The NEC requires that the frame and exposed metal surfaces be at local ground reference potential to avoid electrical shock hazard. A local ground reference may require a driven earth ground conductor at the generator installation site. Make the ground connection as shown in Figure 3-4. Use the appropriate size wire as required by NEC and local codes.

1. Open the enclosure electrical access panel door.
2. Connect the ground wire to the “earth ground connection” terminal shown in Figure 3-4. This is the local ground reference to ground the generator enclosure and frame.

Battery Connections The generator is shipped with no battery installed.

Caution: This generator must have a battery installed for operation. The battery is used during starting and during operation. If engine operation is attempted while the battery is removed, damage to the engine’s electrical components may result.

WARNING: Installation and servicing of batteries is to be performed or supervised by personnel knowledgeable of batteries and the required precautions. Keep unauthorized personnel away from batteries.

WARNING: Do not dispose of battery or batteries in a fire. The battery is capable of exploding. If the battery explodes, electrolyte solution will be released in all directions. Battery electrolyte solution is caustic and can cause severe burns and blindness. If electrolyte contacts skin or eyes, immediately flush the area with water and seek medical attention quickly.

WARNING: Do not mutilate the battery . The battery contains electrolyte solution which is caustic and can cause severe burns and blindness. If electrolyte contacts skin or eyes, immediately flush the area with water and seek medical attention quickly.

WARNING: A battery presents a risk of electrical shock hazard and high short circuit current. The following precautions are to be followed when working on batteries:

1. Remove watches, rings, necklaces and all other metal objects.
2. Use tools with insulated handles.
3. Wear safety goggles, rubber gloves and boots.

WARNING: The battery electrolyte is a dilute sulfuric acid that is harmful to the skin and eyes. It is electrically conductive and corrosive. The following precautions are to be followed when working on batteries:

1. Wear full eye protection (safety glasses or goggles) and protective clothing.
2. Where electrolyte contacts the skin, flush the area immediately with water and wash it off using soap and water.
3. Where electrolyte contacts the eyes, immediately flush the eye thoroughly with water and seek medical attention quickly.
4. Spilled electrolyte is to be washed down with an acid neutralizing agent. A common practice is to use a solution of one pound (500 grams) bicarbonate of soda to one gallon (four liters) of water. the bicarbonate solution is to be added until evidence of reaction (foaming) has ceased. The resulting liquid is to be flushed with water and the area dried.

WARNING: A battery presents a risk of fire because they generate hydrogen gas. Hydrogen gas is extremely explosive. Never jump start a battery, smoke in the area around the battery or cause any spark to occur in the area around the battery. The following precautions are to be followed when working on batteries:

1. Do not smoke when near batteries.
2. Do not cause flame or spark in battery area.
3. Discharge static electricity from body before touching batteries by first touching a grounded metal surface.

WARNING: Disconnect the battery's ground terminal before working in the vicinity of the battery or battery wires. Contact with the battery can result in electrical shock when a tool accidentally touches the positive battery terminal or wire. The risk of such shock is reduced when the ground lead is removed during installation and maintenance.

Procedure: The correct type battery must be installed in the battery compartment provided, see Table 3-5. Installation and servicing of batteries is to be performed or supervised by personnel knowledgeable of batteries and the required precautions. Keep unauthorized personnel away from batteries.

1. Open access doors and locate battery tray.
2. Remove battery cables from the battery, the (-) negative first then the (+) positive.
3. Remove the Battery Hold Down Bar and Rods.
4. Remove the old battery and place the correct new battery (see Table 3-5) on the tray.
5. Install the Battery Hold Down Bar and Rods as shown in Figure 3-5.
 - a. Place the bent end of the Battery Hold Down Rod through the hole in the Battery Tray.
 - b. Place the threaded end of the Battery Hold Down Rod through the hole in the Battery Hold Down Bar and secure with flat washer, lock washer and nut.
 - c. Repeat steps a and b for the other Battery Hold Down Rod.

Figure 3-5 Battery Installation

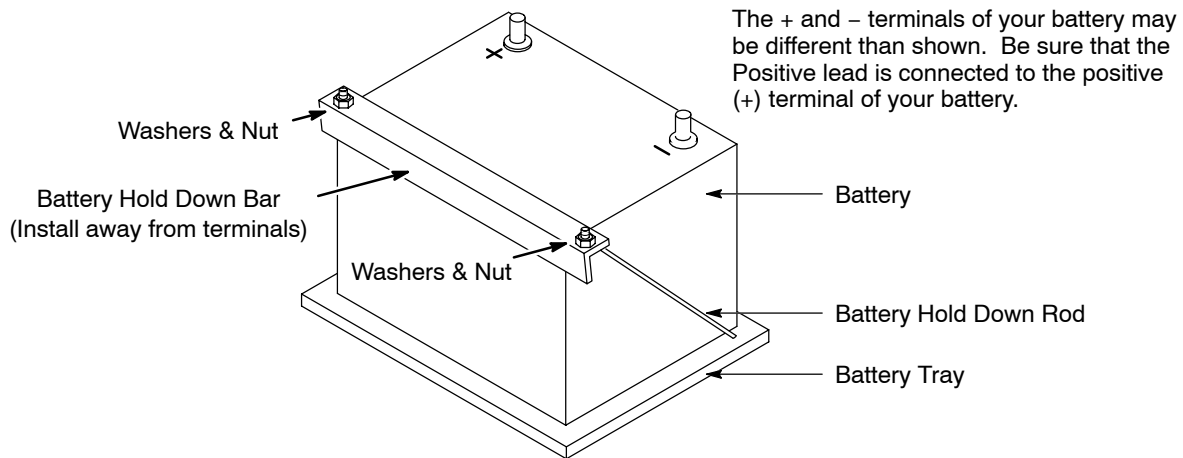

6. Connect the positive lead to the positive (+) battery terminal.
7. Connect the negative lead to the negative (-) battery terminal.
8. Do not lay tools or metal parts on top of batteries.
9. Connect charging source to the battery terminals.
10. Disconnect the battery's ground terminal before working in the vicinity of the battery or battery wires. Contact with the battery can result in electrical shock when a tool accidentally touches the positive battery terminal or wire. The risk of such shock is reduced when the ground lead is removed during installation and maintenance.

Recommended Engine Oil and Battery Type

When replacing batteries, use only the recommended battery for your generator, see Table 3-5.

Table 3-5 Oil & Battery Recommendations

MODEL	SUMMER OIL	WINTER OIL	OIL CAPACITY	RECOMMENDED BATTERY	(AMPS) COLD CRANKING
TS25	SAE. 20W/50	5W/30	8.6 QTS	BCI Group 24	925
TS35	SAE. 20W/50	5W/30	8.5 QTS	BCI Group	925
TS45	SAE. 20W/50	5W/30	11.8 QTS	BCI Group	925
TS60	SAE. 20W/50	5W/30	11.8 QTS	BCI Group	925
TS80	SAE. 20W/50	5W/30	14.0 QTS	BCI Group	925
TS130	SAE. 20W/50	5W/30	18.0 QTS	BCI Group	(2) 750
TS175	SAE. 20W/50	5W/30	34.0 QTS	BCI Group	(2) 750
TS250	SAE. 20W/50	5W/30	34.0 QTS	BCI Group	(2) 750
TS400	SAE. 20W/50	5W/30	45.0 QTS	BCI Group	(2) 750

Post Installation Checks

When the initial installation is complete, these checks must be performed before starting the engine. These checks are not required before each start, only after the initial installation.

1. Generators that have been in transit or storage for long periods may be subjected to extreme temperature and moisture changes. This can cause excessive condensation, and the generator windings should be thoroughly dried before bringing the generator up to full nameplate voltage. If this precaution is not taken, serious damage to the generator can result.

Caution: Do not apply high voltage to windings (do not start the generator) in a moisture-saturated condition. Moisture can cause insulation breakdown, making it necessary to return the generator to the factory for repair, and consequent expense and loss of time.

Note: These precautions are especially necessary in locations such as seaboard installations and other high humidity areas. Some installations will be in atmospheres that are much more corrosive than others. Prevention of a failure is better than being forced to make a repair.

2. Verify that the transfer switch is in Utility Power mode. No power must be present at the generator or transfer switch connections. Verify with a voltmeter.
3. Verify that the engine starting battery is disconnected so accidental starting is not possible.
4. Verify generator is securely mounted and anchored to cement pad (skid mount only).
5. Verify that proper clearance exists on all sides and top of enclosure.
6. Verify no debris (buildup of leaves, grass, sand, snow, etc.) is present.
7. Assure generator is a safe distance from any flammable or combustible material.
8. Verify that the three phase generator power (L1, L2, L3 and N) are properly connected to the transfer switch.
9. Verify that the generator and transfer switch load are voltage compatible.
10. Verify that no load is connected to the circuit breaker and/or transfer switch.
11. Inspect the engine and generator and verify that there are no loose wires or components. Tighten if necessary.
12. Verify that the ground conductor is of correct wire size and properly connected.
13. Verify engine oil level is full. Refer to engine manual if necessary.
14. Verify engine coolant level is full. Refer to engine manual if necessary.
15. Verify exhaust system to assure it is in properly connected and pointing away from occupied living space, air entry routes (doors, windows, vents etc.) and combustible materials.

Post Installation Checks Continued

16. Place the voltage output selector switch in the appropriate position.
17. Verify all loads are disconnected.
18. Verify the Master Control is in the “Stop” position.
Connect the engine starting battery to the starter. Verify it is installed correctly.
19. Verify the fuel source is available.
20. Remove all tools, rags, etc. from inside the generator enclosure. Close all enclosure doors and be sure no hands are inside the generator enclosure when it starts.
21. Start the generator.
22. The engine should begin to crank and start when the fuel moves to the engine. If the engine fails to start, refer to Section 5 Troubleshooting.
23. With the engine running, several checks must be made:
 - a. Verify there are no fuel leaks. If a fuel leak is detected, stop the engine (set the Master Control in the “Stop” position) immediately and repair the leak before proceeding.
 - b. Verify there are no coolant or oil leaks. If a leak is detected, stop the engine (set the Master Control in the “Stop” position) immediately and repair the leak before proceeding.
 - c. Verify that operation is smooth. If squeals, vibrations or other abnormal sources of noise exist, stop the engine (set the Master Control in the “Stop” position) immediately and repair before proceeding.
 - d. Verify the correct voltage exists at the receptacles.

WARNING: Engine coolant is under pressure and is near the boiling point of water when engine is hot. Do not open the coolant system until the engine has completely cooled. Hot coolant can cause severe burns and other injuries. When engine is cool, coolant level can be checked.

24. After the operation checks are made, stop the engine (set the Master Control in the “Stop” position) and wait 2 hours for the engine to cool. When the engine is cool, check engine oil and coolant levels as instructed in the engine operation manual.
25. Close all enclosure covers. The post installation checks are now complete.

Section 4 Operation

Towing the Generator

- WARNING:** Never allow a person to ride in or on a trailer that is being towed. All states prohibit passengers in towed vehicles. A person can fall off and be struck by another vehicle or run over by the towed trailer. Failure to observe this warning can result in death.
- WARNING:** Before using a tow vehicle with a trailer mounted generator, verify that the vehicle is designed for the load. Using a vehicle that is too small is very dangerous. Be certain that it can handle the M.G.V.W. (Maximum Gross Vehicle Weight) and the tongue weight for safe towing and braking.
- WARNING:** For a new trailer, the wheel lug nuts should be tightened to the proper torque specification before use, after 50 miles of operation, after 100 miles of operation and periodically thereafter. Failure to check the lug nuts for proper tightness can result in an accident due to a wheel falling from the trailer.
- WARNING:** Never operate a trailer or tow vehicle that has a loose, missing or broken lug nut. The trailer is designed for safe operation with all lug nuts installed and all at the proper torque rating. Operating the trailer with one or more broken or missing lug nuts greatly increases the load on the remaining nuts and can cause failure of the remaining nuts that can result in an accident due to a wheel falling from the trailer.
- Make sure the tow vehicle is able to tow the load. Vehicle brake capacity is extremely critical and the tow vehicle must be able to handle the additional weight of the trailer mounted generator. Radiator and transmission cooling must also be considered.
 - Be sure hitch capacity is equal to or greater than the load when mounted on the vehicle.
 - Be sure the size and rating of the hitch ball is equal to or greater than the load.
 - Make sure the safety chain(s) rating is equal to or greater than twice the maximum gross vehicle weight rating of your trailer.
 - It is illegal to transport passengers in any trailer.
 - Reduce weight in car trunk and rear seat areas by the amount of tongue weight of your trailer.
 - Any alterations or changes made to the trailer void any express or implied warranties on the trailer or towing equipment.

Selecting the Proper Towing Equipment

When selecting the proper towing equipment, the two most important factors that must be considered are the M.G.V.W. (Maximum Gross Vehicle Weight) and the Tongue Weight (trailer tongue weight at the hitch). The M.G.V.W. is the total weight of the trailer plus the payload in the trailer. The tongue weight is the downward pressure exerted at the coupler. The easiest way to measure the gross vehicle weight is to place the loaded trailer on a vehicle scale making sure that the scales are supporting the entire weight of the loaded trailer.

The easiest method to measure tongue weight is to place the jack stand (trailer tongue) on a scale making sure the trailer is level. The trailer tongue should be level and in its normal towing position. Tongue weight should be 10% of trailer weight and not more than 10% of M.G.V.W.

Tow Vehicle

Make sure the vehicle you are using to tow the trailer is capable of towing the weight. Check the vehicle Owner's Manual for towing capability of the towing vehicle or contact the vehicle manufacturer for this information. Make sure the tow vehicle is able to tow the load. Vehicle brake capacity is extremely critical and the tow vehicle must be able to handle the additional weight of the trailer mounted generator. Radiator and transmission cooling must also be considered. Seek expert advice to select the proper tow vehicle. Trailers with a gross vehicle weight rating that exceeds 10,000 lbs require special consideration.

Table 4-1 Tow Hitch Capacity

Tow Vehicle	Hitch Class	Maximum Tow Capacity	Maximum Tongue Weight
Compact Vehicle	Sub Class I	1000 Lbs.	100 Lbs.
Compact Vehicle	Class I	2000 Lbs.	200 Lbs.
Mid & Full Size Vehicle	Class II	3500 Lbs.	300 Lbs.
3/4 Ton or larger Truck	Class III	5000 Lbs.	500 Lbs.
1 Ton or larger Truck	Class IV	10000 Lbs.	1000 Lbs.
Class 3-8 Vehicle	Custom Engineered	Custom Engineered	Custom Engineered

Selecting the Proper Towing Equipment Continued

Electrical Trailer Wiring

All trailers must have taillights, brake lights and turn signals connected to the towing vehicle's electrical system. It is also recommended that a heavy duty turn signal flasher and emergency flasher (if separate) be installed since the trailer lights place an extra load on car flasher units.

Towing Heavy Trailer Loads

1. Trailer brakes. In all cases refer to your vehicle's owner manual and the trailer operating manual to be certain you have an adequate braking system to handle the vehicle/trailer combination. Also, State and local requirements, road and weather conditions and grade of road, etc. should be considered for trailer braking.
2. Additional equipment. The following items may be helpful for towing heavy loads. Consult your vehicle's owner manual or dealership for recommended towing accessories.
 - a. Overload Springs
 - b. Overload or air shocks
 - c. Transmission Oil Cooler
 - d. Engine Oil Cooler
 - e. Coolant recovery System
 - f. Heavy Duty Fan
 - g. Side View Mirrors
 - h. Sway Control

Safe Driving Tips

1. Loading Trailer. The trailer should be loaded so that the downward tongue weight is approximately 10% of the gross vehicle weight. The trailer tongue should be level with the tow vehicle coupling during towing. Adjust load, hitch and coupling as necessary to ensure trailer tongue remains level during towing.
2. Following and stopping distance. The stopping distance is increased when towing a trailer. A rule of thumb for the minimum distance that should be maintained between you and the preceding car on dry pavement is one car and trailer length (2 car lengths) for every 10 MPH you are traveling. The distance should be increased accordingly depending on road and weather conditions. Avoid sudden stops if possible.
3. Passing. Accelerating and passing should be done slowly to allow extra distance for passing. Signal well in advance when passing and returning to the proper lane. Allow for the extra length of the trailer before changing lanes. Never change lanes abruptly as this may cause the trailer to sway and push the tow vehicle into a "jack knife" condition.
4. Turning. Allow for the extra length of the trailer. Drive slightly beyond normal turning point to avoid running over curbs and soft shoulders. Turning radius increases when towing.
5. Uphill and Downhill Grades. Reduce speed and use a lower transmission gear for steep or long up or down hill grades. Maintain safe distance from other vehicles.
6. Parking.
 - Avoid parking on uphill or downhill grades
 - Place transmission in "PARK"
 - Apply parking brake.
 - Use wheel chocks.
 - In a parking lot, avoid parking close to other vehicles. Turning radius is greater and it may be impossible to get out of a parking space after a few other vehicles have parked around your vehicle.
7. Trailer Sway. If trailer sway occurs, reduce speed. Apply trailer brakes rather than car brakes to control sway. See step 1 and ensure trailer tongue remains level during towing. If sway persists, seek expert advise.
8. Trailer Backing. Backing a trailer can be frustrating. The most important item to remember is that the trailer will go in the opposite direction of the tow vehicle. It is helpful to have another person help you back the trailer and watch for objects. Turn the vehicle's wheels to the right to make the trailer go left, and vice versa. Put your hand at the bottom of the steering wheel. The trailer will go in the same direction your hand moves (moving your hand to the right will cause the trailer to go right, and vice versa). Sharp steering wheel corrections will cause the trailer to jackknife and may cause damage to the rear of the tow vehicle or the front of the trailer.

Figure 4-1 Trailer Component Identification

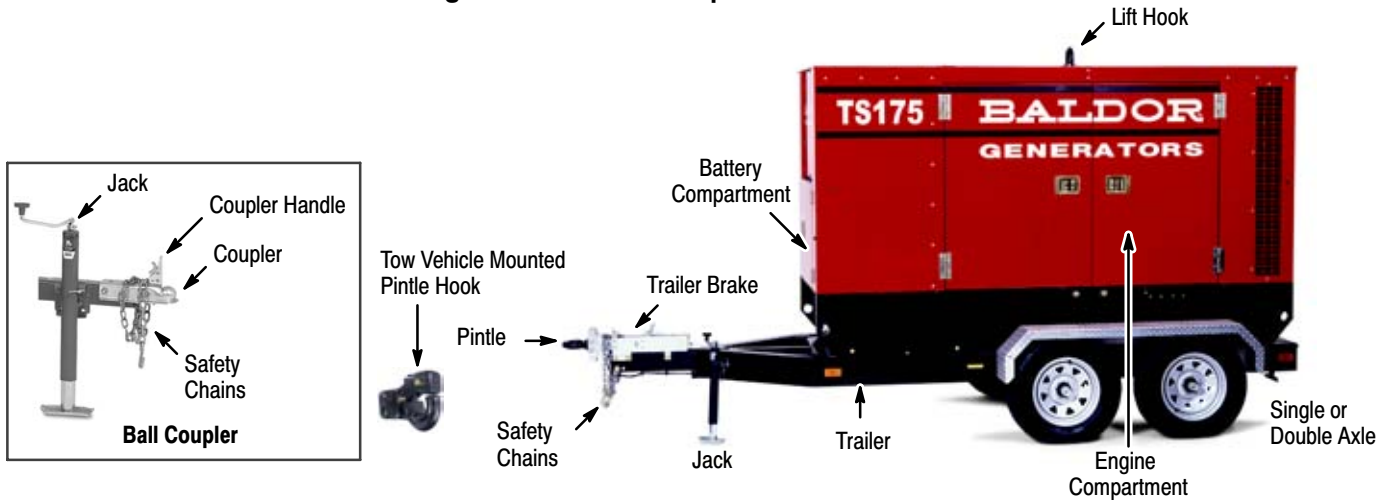

Caution: Large “Engine Compartment Doors” on each side of enclosure must remain closed during operation. If doors remain open, engine will overheat due to insufficient air flow around engine.

Safety Checks The following items should be checked before each use and once every 100 miles of towing:

1. Verify the tow vehicle is designed to tow the trailer before trailer is connected to the vehicle's hitch. Using a tow vehicle that is too small is very dangerous.
2. Verify the stop, tail and turn signals are working properly. Replace damaged lenses, reflectors or bulbs.
3. Check wires for good connections and possible fraying or wearing of insulation.
4. Check and properly maintain the trailer, hitch, jack, ball and coupler.
5. Inspect hitch and ball for damage. Ball or hitch can be damaged in parking, hitting curbs, dragging when crossing ditches or railroad tracks.
6. Check and properly tighten all bolts on trailer, hitch, ball and coupler (including trailer wheels).
7. Check safety chains for wear and do not allow them to drag on ground or roadway.
8. Test breakaway system.
Hydraulic surge brake system, normally have a cable or chain connected to the tow vehicle. In a break away condition, this cable or chain activates the master cylinder and operates the brakes as the trailer stops.
An electric brake system, the emergency breakaway system has a battery, charger, breakaway switch with a pull pin and cable connected to the tow vehicle. In a break away condition, this cable operates the electric brakes (power provided by the brake battery) as the trailer stops.
9. Check all generator mounting hardware for tightness.
10. Check tow vehicle tires for wear and proper inflation. (Check vehicle's owner manual for proper level of inflation of tires for towing a trailer).
11. Check trailer tires for wear and proper inflation. Replace only with a tire of the same size and capacity ratings.
12. Carry emergency flares, reflectors and fire extinguisher.
13. Carry spare light bulbs and fuses.
14. Wheel bearings should be checked and regreased after the first 100 miles, and every 4000 miles thereafter or at least once a year. Wheel bearing grease or a good grade of multi-purpose grease should be used for packing wheel bearings. If you don't know how to repack your wheel bearing, take your trailer to a service shop. Be sure to properly tighten the axle nut and wheel nuts during assembly.
15. For proper tow vehicle maintenance while towing a trailer, check vehicle's owner manual and manufacturer's specifications.

Towing Instructions

See Figure 4-1 for component identification.

1. Be sure the generator is off.
2. Shut all enclosure doors and latch the locks.
3. Back the tow vehicle to within a few inches of the trailer coupler (Pintle or Ball).
4. Be sure the Coupler Handle is in the “UP” (open) position or the Pintle Hook is Open.
5. Adjust the trailer jack for the height of the hitch on the tow vehicle.
6. Back the tow vehicle so the trailer coupler is directly over the tow vehicle ball hitch or the Pintle hook.
7. Lower the trailer so the trailer coupler rests securely on the ball hitch of the tow vehicle. Move the Coupler Handle to the horizontal position and lock it in place to securely hold the ball hitch of the tow vehicle.

OR

Latch the Pintle and lock the Pintle device securely.

Note: If this is not done properly, the trailer may become unhitched when it is towed.

8. Retract the front jack, pull the jack pin and rotate the jack 90 degrees from vertical to the horizontal position, making sure the self-locking pin reseats and the jack is secured to the tow bar (stowed position).
9. Connect safety chains, making sure to cross them. If a safety chain is too long, simply twist it a few turns to shorten the chain before attaching to the tow vehicle.
10. Connect the trailer light connector to the tow vehicle.
11. Test the trailer lights to ensure they are operational.
12. Check tires for proper inflation.
13. Check wheel lug nuts for correct tightness (see Lug Nut Tightness). Wheel nuts/bolts should be torqued before the first road use and after each wheel removal. Check and re-torque after the first 50 miles and again at 100 miles. Check periodically thereafter.
14. Verify that all jacks, pins, cables, and doors are secured and trailer tongue is level.
15. Remove tire chocks (if used). These prevent the trailer from moving when parked.

Lug Nut Tightness

Be sure to use only the fasteners matched to the cone angle of your wheel (usually 60 or 90 degrees.) The proper procedure for attaching your wheel is as follows, see Figure 4-2:

1. If a wheel is removed and installed, start each nut by hand to prevent cross threading.
2. Tighten lug nuts in the following sequence.
 - a. Tighten each bolt in the sequence shown in Figure 4-2 and tighten to one half the torque specified until all lug nuts are tightened to one half the torque.
 - b. Tighten each bolt in the sequence shown in Figure 4-2 and tighten to three fourths the torque specified until all lug nuts are tightened to three fourths the torque.
 - c. Tighten each bolt in the sequence shown in Figure 4-2 and tighten each to the specified torque until all lug nuts are tightened to the correct torque.

Figure 4-2 Lug Nut Tightening Specifications

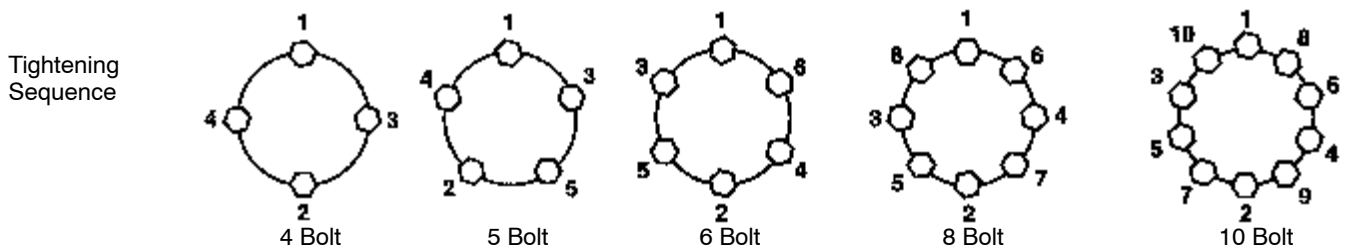

Tightening Sequence

Torque Specification

Description	Application	Minimum Torque (ft-lbs.)	Maximum Torque (ft-lbs.)
1/2" Cone nut	12" – 13" Wheel	50	65
	14" – 16" Wheel	90	120
5/8" Cone nut	Flat Disc Wheel	175	225
5/8" Cone nut	Clamp Ring	190	210
3/4" Hex nut	Demountable Ring Clamp	210	260

Trailer Setup

See Figure 4-1 for component identification. Carefully read all instructions before starting.

1. Locate a suitable, level location. Also be sure there are no overhead wires or obstructions.
The trailer is balanced so the majority of the weight rests on the tow bar (Jack). If on a minor incline, the safest way to position the trailer is to have the tow bar facing down the incline (front of the trailer lower than the rear of the trailer).
2. Install tire chocks if used. These prevent the trailer from moving when parked.
3. Disconnect the safety chains and the trailer light connector from the tow vehicle.
4. Pull the pin on the front jack and rotate the jack 90 degrees to the vertical position. Lock the jack in the vertical position using the pin to secure it.
5. Move the Coupler Handle to the vertical position to release the ball hitch.
OR
Release the Pintle hook.
6. Use the jack to raise the trailer coupler from the ball hitch of the tow vehicle.
7. The tow vehicle can now be moved away from the trailer.
8. Use the jack to level the trailer for operation.

Voltage Selection

WARNING: High voltage is present whenever the engine is running. Electrical shock can cause serious or fatal injury. Always stop engine before connecting or disconnecting power cords or external devices.

WARNING: High voltage is present whenever engine is running. Electrical shock can cause serious or fatal injury. Never operate electrical equipment while standing in water, on wet ground or with wet hands, feet or shoes or while barefoot.

Hard Wire Load Terminal Block, shown in Figure 3-4.

1. Ensure the generator is off.
2. Place voltage select switch in the correct position 208/120, 240/120 or 480/277VAC. Refer to Table 4-2 for voltages available in each position. To ensure the switch position is not accidentally changed, it should be padlocked as shown in Figure 4-3.

Figure 4-3

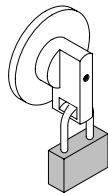

Insert padlock through the hole in the handle. This activates an internal mechanism that prevents handle rotation.

3. Carefully inspect all Individual load cables for broken insulation or other signs of damage. Never use a damaged cable. Replace it before usage.
4. L1, L2, L3, Neutral and Ground cables must be brought into load block compartment through access hole in base of enclosure.
5. Ensure that wires are properly connected and connections are secure.
6. Use disconnect at the load to turn off the load. Do not start engine with load switched "on". Allow engine to come up to speed and warm up before load is switched on.

Note: When the generator is running, opening load block door will cause load disconnect to trip.

7. Observe the output voltage indicator and set the Voltage Adjust (Figure 4-5) for proper voltage.
8. If left unattended, lock all doors to prevent tampering or injury.

Table 4-2 Three/Single Phase Operation

Switch Position	Alternator Winding Connection	Voltage Adjust Position	Voltage at Terminal Lugs						Voltage at Plug Receptacles		
			Line To Line Voltage			Line To Neutral Voltage			120VAC Receptacles	240VAC Receptacles (Twist Lock)	
			L1-L2	L2-L3	L1-L3	L1-N	L2-N	L3-N	L-N	L-L	L-N
480/277	Series High Wye	Minimum	416	416	416	240	240	240	120	208	120
		Middle	460	460	460	266	266	266	133	230	133
		Maximum	480	480	480	277	277	277	139	240	139
208/120	Parallel Low Wye	Minimum	208	208	208	120	120	120	120	208	120
		Middle	230	230	230	133	133	133	133	230	133
		Maximum	240	240	240	139	139	139	139	240	139
240/120	Parallel Low ZigZag	Minimum	□	□	200	100	□	100	100	200	100
		Middle	□	□	220	110	□	110	110	220	110
		Maximum	□	□	240	120	□	120	120	240	120

□ No connection at Terminal Lug #2.

Receptacle Panel Load Connections, see Figure 4-4.

- 240/120VAC voltage is present at the receptacle panel at all times when generator is running.
- Carefully inspect all Individual load cables for broken insulation or other signs of damage. Never use a damaged cable. Replace it before usage.
- Individual load cables may be routed into the receptacle compartment through the Enclosure Electrical Access Panel.
- Individual load cables may be connected or disconnected while generator is running. Use extreme care not to touch any electrical wire or terminal to avoid shock hazard.
- Keep Enclosure Electrical Access Panel closed at all times. This prevents rain or other harmful elements from entering the compartment. Output metering and gauges can be observed through the window in the Enclosure Electrical Access Panel.

Figure 4-4 Receptacle Panel (Single Phase)

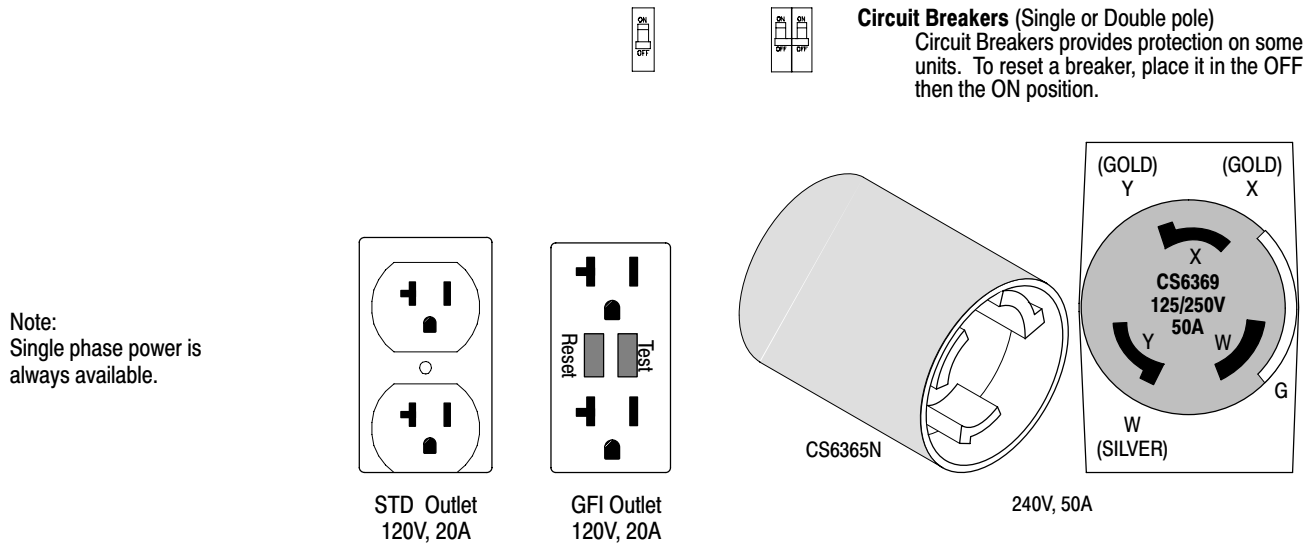

Meters, switches, lights and other operator control components are located in various places on each panel. Figure 4-5 can be used to identify the function and features of each operator control regardless of where it is located on your panel.

Figure 4-5 Operator Control Panel Components

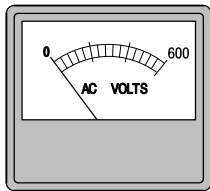

Volts
Analog display of generator output voltage in RMS volts.

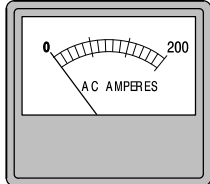

AMPS
Analog display of generator output current in RMS amps.

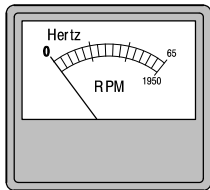

HERTZ
Analog display of generator RPM which relates to the output frequency in Hertz.

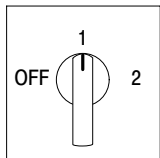

Amps Switch switch (On-Off)
Selects what is displayed on AC Amperes meter.
Off - No AC Ampere display.
1 - Phase 1 current display.
2 - Phase 2 current display.
3 - Phase 3 current display.

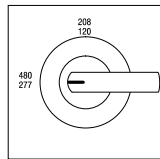

Voltage Select Switch switch
Selects 208/120, 240/120 or 480/277VAC.



BREAKER
or

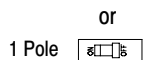
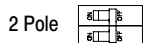

Breaker Circuit Breakers provides protection on some units. To reset a breaker, simply press the center button when tripped or move handle to "Off" then back to "On".

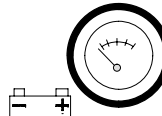

Battery
Displays the voltage of the engine starting battery.



Water Temp
Displays the temperature of the engine coolant.

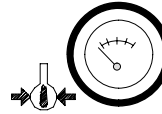

Oil Press
Displays engine oil pressure.



Horn A Horn (annunciator or buzzer) sounds an alarm when operator attention is needed.



Shore Power Inlet Connect an extension cord that has an appropriate rating from utility power to this outlet. To power onboard battery charger, block heater, etc.

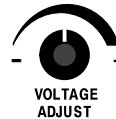

Voltage Adjust
Increase or Decrease the Generator output voltage.



Panel Lights)
Lamps to illuminate the operator panel.



Panel Lights switch (On-Off)
Turns on the panel lights.

FUSE



Fuse Fuses provides protection on some units. (Do not remove while generator is running).



Auto Start Connection for external two wire starting from transfer switch or other controller. Strip the insulation from the remote start wires. Simply press while inserting the wire then release to secure the connection.

Pre-Start Procedure

Before attempting to start the generator set, several things must first be verified or performed. These are:

1. Fill system fuel tank with clean, fresh diesel fuel.
2. Fill engine crankcase to full mark with clean, fresh lubricating oil per engine manufacturer operating guide.
3. Radiator coolant should be checked at the beginning of each day and filled in compliance with the engine manufacturer's guidelines.
4. Secure the generator for operation.
 - a. Skid mounted – the power generating system should be mounted to a smooth, hard surface suitable for supporting the system under all stress conditions.
 - b. Trailer mounted – block wheels to prevent accidental movement. Use jack (Figure 4-1) to level the generator.
 - c. Adequate clearance must be provided for access doors to fully open.

Note: The exhaust also exits radiator end. When positioning a generator system ensure position does not cause a concentration of toxic emissions.

5. Place voltage select switch in the correct position 208/120, 240/120 or 480/277VAC and pad lock it in position if required (Figure 4-3).
6. Carefully inspect all Individual load cables for broken insulation or other signs of damage. Never use a damaged cable. Replace it before usage.
7. L1, L2, L3, Neutral and Ground cables must be brought into load block compartment through access hole in base of enclosure.
8. Ensure that wires are properly connected and connections are secure.
9. Ensure that an external ground connection is made when required for safety.
10. Ensure that the Remote Start wires are properly connected, if used.
11. Use disconnect at the load to turn off the load. Do not start engine with load switched "on". Allow engine to come up to speed and warm up before load is switched on.

Caution: Large "Engine Compartment Doors" on each side of enclosure must remain closed during operation. If doors remain open, engine will overheat due to insufficient air flow around engine.

12. Ensure that Engine Compartment doors are closed for proper ventilation.

Note: Receptacle Panel Load cables may be routed into the receptacle compartment through the Enclosure Electrical Access Panel after generator is started and has warmed up.

Operating Procedures The engine-generator controller is designed to start and stop an engine from either AUTO "Automatic" mode or Manual "NOT IN AUTO". Refer to Figure 4-6.

Manual Start Procedure

1. Press Mode▶ until "Not in AUTO" LED is ON, control is in MAN mode.
2. Press "Start".
3. The controller closes GCB after engine is running and generator parameters are within limits.

Manual Stop Procedure

1. Use disconnect at the load to turn OFF the load. Allow generator cool down if needed.
2. Press "Stop". Press Mode▶ until control is in OFF mode.

AUTO Start Procedure

1. Press Mode▶ until control is in AUT mode.
In Auto mode, the generator will start when the remote start input closes.
GCB is closed automatically when generator voltage is within limits.
2. In Auto mode, the generator will stop when the remote start input opens.

Figure 4-6 Operator Control Panel

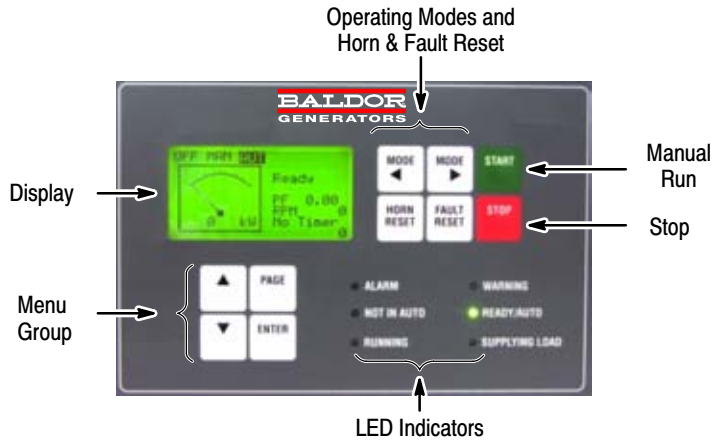

LED Indicators

Alarm (red) – Alarm (shutdown) condition occurred. Annunciates & shuts down generator.
 Not In Auto (red) – Control is not in auto mode and cannot provide standby power.
 Running (green) – Generator is running, no alarms or warnings.
 Warning (yellow) – A warning condition has occurred. Annunciates only.
 Ready/Auto (green) – Control is in Auto mode and ready to provide standby power.
 Supplying Load (green) – Generator is providing output voltage to load.

Table 4-3 Alarm & Warning Conditions

Alarm	Warning	
X		High Coolant temperature
X		Low Oil pressure
X		Low Fuel level
X		Generator Over Voltage
X		Generator Over Frequency
X		Generator Over Current
	X	Generator Overspeed
	X	Coolant temperature High/Low
	X	Starting battery Over/Under Voltage

Manual Run

Immediately energizes the crank cycle to start the generator set and produce power.

Start

Start generator set operation.

Stop

Stops the Engine and generator set.

Display

Displays setpoints, adjustments, Alarms and Warning conditions and Operating Mode selections.

Page

Changes menu displayed – Measurement, Adjustment or History.

Mode ◀ and ▶

Allows selection of OFF – MAN – AUTO mode choices.

Horn Reset

Deactivates the Horn output.

Fault Reset

Acknowledge Alarms and Warnings.

▲ and ▼

Selects the menu choice, select the setpoint or select the menu or increase/decrease the setpoint value.

Enter

Confirm and accept changed setpoint value.

Digital Engine Controller Description EM0046A21 (MRS17) Continued

Operating Mode Press Mode ◀ or ▶ to scroll through the list of operating modes: Off, Manual and Automatic. The control mode is shown in the highlighted area at the top of the display, Figure 4-7. When the desired Control Mode is highlighted, press Start to begin operation. Press Stop to terminate operation.

OFF – Generator set operation is not allowed.

MAN – Press Start to manually start the generator set immediately. Press Stop to stop the generator set immediately.

AUT – Start and Stop buttons are ignored. The binary input terminal conditions start and stop the generator set.

Display Menus

Three display menus are available: Measurement, Adjustment and history. Press the Page button repeatedly to display each menu. Use ▲ ▼ and Enter keys to change and accept setpoint values or press the Page button to cancel changes.



Measurement Menu

The measurement menu, shown in Figure 4-7 displays the operating mode, and operating parameters such as kW, engine RPM etc.

Figure 4-7 Measurement Menu

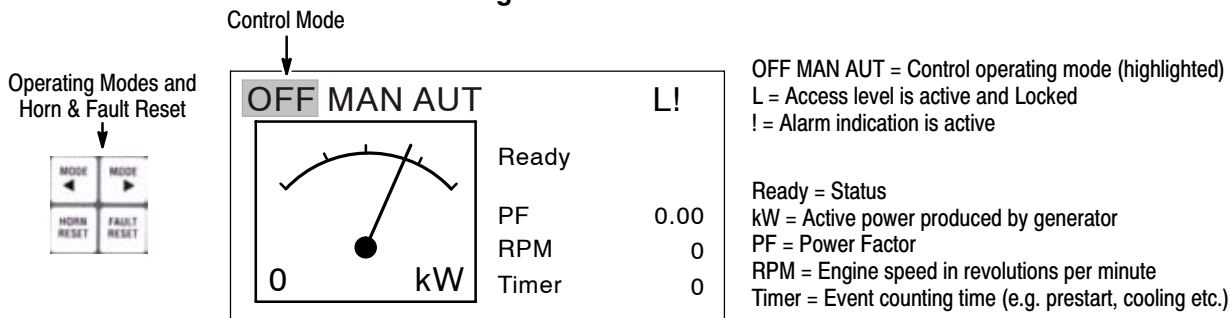

OFF Mode

Starting of the generator set is not possible. Outputs STARTER (BO1), Generator CB (BO3) and FUEL SOLENOID (BO2) are not energized. No action if buttons START and STOP are pressed.

MAN Mode

START button starts the generator set. Generator CB (BO3) is closed after engine is running and generator parameters are within limits.

STOP button opens Generator CB (BO3) and stops the generator set.

This operation is further defined in Table 4-4.

AUT Mode

No action if buttons START and STOP are pressed.

Engine Start/Stop request is given by binary input REM Start/Stop (BI1).

Generator CB (BO3) is closed automatically when generator voltage is within limits.

Digital Engine Controller Description EM0046A21 (MRS17) Continued

Table 4-4 Manual Mode Sequence Description

Menu	Status	Condition of Transition	Action [†]	Next State
Main Measurement	Ready	Start request	PRESTART on, Prestart time counter started	PRESTART
		RPM > 2 or Oil pressure detected or Gen voltage > 10V		Stop (Stop fail)
		OFF mode selected or Shut down alarm active		Not Ready
	Not Ready	RPM < 2, Oil pressure not detected, Vgen < 10V, no shutdown alarm active, other than OFF mode selected		Ready
	Prestart	Prestart time elapsed	STARTER on, FUEL SOLENOID on, MaxCrank time counter started	Cranking
	Cranking	RPM > Start RPM	STARTER off, PRESTART off	Starting
		D+ input activated or oil pressure detected or Gen voltage > 25% Vgnom	STARTER off, PRESTART off	Cranking
		MaxCrank time elapsed, 1st attempt	STARTER off, FUEL SOLENOID off, STOP SOLENOID on, CrankFail pause timer started	Crank pause
		MaxCrank time elapsed, last attempt	STARTER off, PRESTART off	Shutdown (Start fail)
	Crank Pause	CrankFail pause elapsed	STARTER on, FUEL SOLENOID on, STOP SOLENOID off, MaxCrank time counter started	Cranking
	Starting	80% Nominal speed reached	READY TO LOAD on, MaxStabTime counter started	Running
	Running	Stop request	READY TO LOAD off, Cooling time timer started	Cooling
		RPM = 0 or any other shutdown condition	READY TO LOAD off, FUEL SOLENOID off	Shutdown
		Generator CB = Closed		Loaded
	Loaded	Generator CB = Opened		Running
		RPM = 0 or any other shutdown condition	FUEL SOLENOID off, STOP SOLENOID on, READY TO LOAD off	Shutdown
	Cooling	Cooling time elapsed	FUEL SOLENOID off, STOP SOLENOID on	Stop
		RPM = 0 or any other shutdown condition	FUEL SOLENOID off, STOP SOLENOID on	Shutdown
		Start request	READY TO LOAD on	Running
	Stop	RPM = 0, Oil pressure not detected, Vgen < 10V		Ready
60 sec. Elapsed			Stop (Stop fail)	

[†] Some output conditions are optional and may require additional programming of field connection. See appropriate wiring diagram.

Adjustment Menu

The adjustment menu, Figure 4-8 allows setting engine and generator values such as Passwords, Pre-Start Time, Crank Time, Cool Down Time, Alarm Conditions and values, Shutdown Conditions and values, power transfer settings, etc.

Figure 4-8 Adjustment Menu

```

> ENGINE BASIC
ENGINE PROT
GEN BASIC
GEN PROTECT
MAINS FAIL
    
```

Use ▲ and ▼ to move the cursor to the desired parameter.
Press ENTER to select the parameter group.
Press PAGE to move to the next page of menu items.

History Menu

The History file stores 117 records. When full, the oldest record is overwritten. Use ▲ and ▼ to move through the records and Enter key to select the record you want to view. Then use the ▲ and ▼ to move through the data in that record. Each record has a date and time stamp to help discover what happened at a certain time.

Alarms

Following alarms are available:

Sensor fail (FLS) see Table 4-5

Sensor fail is detected when measured value is 6% out of selected sensor characteristic.
Sensor fail is indicated by ##### symbol instead measured value.

Warning (WRN) see Table 4-5

When warning comes up, only alarm outputs and common warning output are closed.

Shut down (SD) see Table 4-5

When the shut-down alarm comes up, IntelliLite opens outputs GCB CLOSE/OPEN, FUEL SOLENOID, STARTER and PRESTART to stop the engine immediately. Alarm outputs and common shutdown output are closed. Active or not reset protection disables start.

Table 4-5 Possible Warnings

Events specification	Protection type	Binary output available, Table 4-7.
Wrn Oil press	WRN	YES
Sd Oil press	SD	YES
Wrn Water temp	WRN	YES
Sd Water temp	SD	YES
Wrn Wtemp Low	WRN	YES
Wrn Fuel Level	WRN	YES
Sd Fuel Level	SD	YES
Analog inp IOM/PTM - Wrn	WRN	YES
Analog inp IOM/PTM - Sd	SD	YES
Binary input	Configurable	YES
Battery voltage <, >	WRN	YES
Battery flat	SD	YES
Start fail	SD	YES
ParamFail	NONE	NO
Vgen <, >	SD	YES
Vgen unbl	SD	YES
Fgen <, >	SD	YES
Igen unbl	SD	YES
Overload	SD	YES
RPM over	SD	YES
RPM under	SD	YES
TotalStop	SD	NO
PickupFault	SD	NO
Stop fail	SD	YES
WrnServiceTime	WRN	NO
ChrgAlternFail	WRN	YES
SprinklActive	WRN	NO
Wrn RA15 fail	WRN	NO
Sd IOM fail	SD	NO

Inputs and Outputs

Any Binary input or output can be configured to any controller terminal Inputs are BI1 – BI6, Outputs are BO1 – BO6) or changed to different function by LiteEdit software. There is fixed 1 sec delay when any binary input is configured as protection.

Table 4-6 Binary Inputs

Alarm	Alarm type Warning or Shut down Alarm active All the time, or Engine running only
Rem start/stop	External request for engine run. AUT mode only.
Emergency stop	If the input is opened, shut down is immediately activated. Input is inverted (normally closed).
Sprinkler	If the input is closed all alarms are disabled except the binary input EMERGENCY STOP and "engine over speed protection".
Access lock	If input is closed, no setpoints can be adjusted from controller front panel and gen-set mode (OFFMAN-AUT) cannot be changed.
Rem start/stop	External request for engine run. AUT mode only.
Remote OFF	If closed, iL is switched to OFF mode (there are four modes OFF-MAN-AUT-TEST). If open, controller is switched back to previous mode.
Start	Binary input has the same function as Start button. It is active in MAN mode only.
Stop	Binary input has the same function as Stop. It is active in MAN mode only.
FaultRes	Binary input has the same function as Fault reset button.
HornRes	Binary input has the same function as Horn reset button.

Table 4-7 Binary outputs

Starter (relay output)	The closed relay energizes the starter motor. The relay opens if: <ul style="list-style-type: none"> • The firing speed is reached or • Maximum time of cranking is exceeded or • Request to stop occurs
Fuel solenoid (relay output)	Closed output opens the fuel solenoid and enables the engine start. The output opens if: <ul style="list-style-type: none"> Emergency stop occurs or Cooled gen-set is stopped or In pause between repeated starts
GCB Close/Open	The output controls the generator circuit breaker.
Prestart	Output is closed prior to the engine start (Prestart) and opens when START RPM speed is reached. During repeated crank attempts the output is closed too. The output could be used for pre-glow, pre-heat or prelubrication.
Ready to Load	Output is closed if genset is running and all electric values are in limits no alarm is active – it is possible to close GCB or it is already closed. The output opens during cooling state.
CommonWrnSd	Output is closed if : <ul style="list-style-type: none"> • any warning or shutdown occurs or • the gen-set malfunctions The output opens if: <ul style="list-style-type: none"> • FAULT RESET is pressed The output closes again if a new fault occurs.
Prestart	Output is closed prior to the engine start (Prestart) and opens when START RPM speed is reached. During repeated crank attempts the output is closed too. The output could be used for pre-glow, pre-heat or prelubrication.
Idle/Nominal	Countdown when Start speed reached. The Underspeed protection is not evaluated during idle period. A Start fail protection occurs if the RPM drop below 2RPM during idle.
GCB Close/Open	The output controls the generator circuit breaker.
AnImIOM1..4 Wrn	Output is closed if the corresponding IG-IOM or IG-PTM Analog input warning is active.

Table 4-7 Binary outputs Continued

GenParamsOK	The output is same as generator status LED on panel. Output is closed if genset is running and all genset electric values are in limits.
CommonWrnSd	Output is closed if : Any warning or shutdown are active or the gen-set malfunctions The output opens if: FAULT RESET is pressed. The output closes again for a new fault.
CommonWrnSd	Output is closed if : Any warning or shutdown occurs or the gen-set malfunctions The output opens if: FAULT RESET is pressed or the output closes again for a new fault.
Horn	Output is closed if: Any warning or shutdown are active or the gen-set malfunctions The output opens if: FAULT RESET is pressed, HORN RESET is pressed or Max time of HORN is exceeded (Horn timeout). Output closes again at next fault.
Ready/Auto	Output is closed if controller is ready in AUTO mode – no Shut down or Slow stop alarm is active,
Ready	Output is closed if: Gen-set is not running and No Shut down or Slow stop alarm is active and Controller is not in OFF mode
Ready to load	Output is closed if genset is running and all electric values are in limits no alarm is active – it is possible to close GCB or it is already closed. The output opens during cooling state.
Stop solenoid	The closed output energizes stop solenoid to stop the engine. The output opens again 10 s after RPM < 2 and Generator voltage < 10 VAC and Oil pressure < Engine params: Starting oil.
ChrgAlternFail	Output is closed if gen-set is running and D+ input not energized. The output opens, if alarm is not active and FAULT RESET is pressed. Note: Treshhold level for D+ input is 80% supply voltage.
Vgen failed	Output is closed if the generator over/under voltage shutdown alarm or voltage asymmetry shutdown alarm activates. The output opens, if alarm is not active and FAULT RESET is pressed.
fgen failed	Output is closed if the generator over/under frequency shutdown alarm activates. The output opens, if alarm is not active and FAULT RESET is pressed.
Overload	Output closes if the generator overload shutdown alarm activates. The output opens, if alarm is not active and FAULT RESET is pressed.
Stop failed	Output closes when the engine has to be stopped, but speed or frequency or voltage or oil pressure is detected. This protection goes active 60s after stop command. The output opens, if alarm is not active and FAULT RESET is pressed.
Overspeed	Output closes if the gen-set over speed alarm activates. The output opens, if alarm is not active and FAULT RESET is pressed.
Underspeed	Output closes if the gen-set under speed alarm activates. The output opens, if alarm is not active and FAULT RESET is pressed.
Start failed	Output closes after the gen-set start-up fails. The output opens, if alarm is not active and FAULT RESET is pressed.
Overcurrent	Output closes if the generator IDMT over current or current unbalance or short current alarm activates. The output opens, if alarm is not active and FAULT RESET is pressed.
Battery flat	Output closes when iL performs reset during start procedure (probably due to weak battery). The output opens, if alarm is not active and FAULT RESET is pressed.
V batt failed	Output closes when battery over/under voltage warning appears. The output opens, if alarm is not active and FAULT RESET is pressed.

Table 4-7 Binary outputs Continued

Common Wrn	Output closes when any warning alarm appears. The output opens, if alarm is not active and FAULT RESET is pressed.
Common Sd	Output closes when any shut-down alarm appears. The output opens, if alarm is not active and FAULT RESET is pressed.
Sd OilPress	Output closes if the oil pressure shutdown alarm activates. The output opens, if alarm is not active and FAULT RESET is pressed.
Wrn OilPress	Output closes if the oil pressure warning alarm activates. The output opens, if alarm is not active and FAULT RESET is pressed.
Sd Water Temp	Output closes if the water temperature shutdown alarm activates. The output opens, if alarm is not active and FAULT RESET is pressed.
Wrn Water Temp	Output closes if the water temperature warning alarm activates. The output opens, if alarm is not active and FAULT RESET is pressed.
OFF mode	The output is closed, if OFF mode is selected.
MAN mode	The output is closed, if MAN mode is selected.
AUT mode	The output is closed, if AUT mode is selected.
Sd FuelLevel	The output closes if the Fuel level shutdown alarm activates.
Wrn FuelLevel	The output closes if the Fuel level warning alarm activates.
WrnTempLow	The output closes if the low water temperature warning alarm activates.
Not In Auto	The output closes in OFF and MAN mode.
Vgen warning	The output closes if the generator over/under voltage warning alarm activates.
fgen warning	Output closes if the generator over/under frequency warning alarm activates.
Overload wrn	Output closes if the generator overload warning alarm activates.
Running	Output closes if the engine is in Running state.
ServiceTime	Output closes if the ServiceTime alarm activates. The output opens, if alarm is not active and FAULT RESET is pressed.
BI1 ... BI6 – stat IOM BI1 ... IOM BI8 – stat	The outputs give information about the assigned binary input. In case the assigned binary input is configured to alarm type, then the output closes when the alarm activates. The output opens, if alarm is not active and FAULT RESET is pressed. In case the assigned binary input is configured to any control function, the output propagates the state of the input.
AnInIOM 1..4 Sd	Output closes if shutdown alarm on the appropriate IOM or PTM analog input activates. The output opens, if alarm is not active and FAULT RESET is pressed.
ECU CommOK	Output is closed when ECU communication is OK.
VP warning	Output is closed when at least on of following alarms is active: Overspeed Alarm, Oil Pressure Alarm, Oil Temperature Alarm, Coolant Temperature Alarm, Coolant Level Alarm, Charge Alarm
Supplying load	Closed when the generator current is > 0,5% of the CT ratio. Exact formulas: Output is closed when the current at least in one phase is for 1 sec over CT ratio/200+2 Output is opened when the current in all three phases is for 1 sec below CT ratio/200+2 Note: Values are truncated after division, not rounded

Analog Inputs

Three analog inputs for resistive sensor 0 to 2400 Ω measuring are available on IL controller. Use LiteEdit software to modify configuration. The Analog inputs values assignment (AI1 = Oil press, AI2 = Water temp, AI3 = Fuel level) is fixed. It is possible to configure on each Analog input:

- Reading from IL Analog inputs or from Engine Control Unit via CAN bus (J1939)
- Sensor characteristics from the list,
- Value dimension (e.g. psi – bars, °F – °C, % – l)
- Number of decimal points (0, 1, 2, ...).

Note: Corresponding Analog input terminal is dead when reading is switched to ECU.

All values from ECU shall show ####, but no alarm is displayed when CAN communication is interrupted.

Warning and shut-down limits are adjusted in Engine protection group.

Table 4-8 Analog Inputs

AI1 Oil press	Oil pressure analog input. Default VDO sensor in range 0 to 145 psi.
AI2 Water temp	Water temperature analog input. Default VDO sensor in range 32 to 212°F
AI3 Fuel level	Fuel level analog input. Default VDO sensor 0–180R = 0–100%.

Set points

Table 4-9 Setpoints

EnterPassword	Password is a four-digit number. Password enables change of relevant protected set points Use ↑/↓ keys to set and ENTER key to enter the password.
ChangePassword	Use ↑/↓ keys to set and ENTER key to change the password.
Gen-set name	User defined name, used for IntelliLite identification at remote phone or mobile connection. Gen-set name is max 14 characters long and have to be entered using LiteEdit software.
Nomin power(3ph)	Nominal power of the generator in three phases connection. Step: 1 kW; Range: 1 – 3000 kW
Nomin power(1ph)	Nominal power of the generator in single-phase connection. Step: 1 kW; Range: 1 – 3000 kW
CT Ratio	Gen-set phases current transformers ratio. Step: 1 A; Range: 1 – 5000 A / 5A
PT ratio	Gen-set potential transformers ratio. Step: 0,1 V / V; Range: 0,1 – 500,0 V / V
Nominal freq	Nominal generator frequency (usually 50 or 60 Hz) Step: 1Hz; Range: 45 – 65 Hz
Gear teeth	Number of teeth on the engine gear for the pick-up. Set to zero, if no pick-up is used. Engine speed is counted from the generator frequency. Step: 1; Range: 0 – 500 Note: Generator frequency can be used only when generator voltage (min 5V) is present before reaching of the firing speed (Starting RPM) after start.
Nominal RPM	Nominal engine speed. Step: 1RPM; Range: 100 – 4000 RPM.
Mode IL [OFF, MAN, AUT]	Equivalent to Controller mode changes by MODE▶ or MODE◀ buttons. Note: Controller Mode change can be separately password protected.
RS232 mode [Standard/Modbus]	Communication protocol switch. Standard: LiteEdit communication protocol. Modbus: Modbus protocol. Note: For detail description see chapter Modbus protocol.
Num rings AA	Number of rings prior to open modem connection. Step: 1; Range: 1 – 30 Note: NumberRings AA change is not activated immediately. It is activated after controller is switched on or when modem is connected to controller.

Table 4-9 Setpoints Continued

Start RPM	"Firing" speed when iL controller stops cranking (starter goes OFF). Step: 1% of nominal RPM; Range: 5 – 50 %
Starting POil	When reached controller stops cranking (starter goes OFF). Step: 0,1 psi; Range: –100 – 10000 Note: There are three conditions for stop cranking: Starting RPM, StartingPOil and D+ (when enabled). Starter goes off when any of these conditions is valid.
Prestart time	Time of closing of the PRE–START output prior to the engine start. Set to zero if you want to leave the output PRE–START open. Step: 1s; Range: 0 – 600 s
MaxCrank time	Maximum time limit of cranking. Step: 1s; Range: 1 – 60 s
CrnkFail pause	Pause between crank attempts. Step: 1s; Range: 5 – 60 s
Crank attemps	Max number of crank attempts. Step: 1; Range: 1 – 10
Idle time	Idle time delay starts when RPM exceeds Start RPM . Start fail is detected when during Idle state RPM decreases below 2. During the Idle time timer running the binary output IDLE/NOMINAL is opened, when it elapses the IDLE/NOMINAL output closes. Binary output IDLE/NOMINAL opens during Cooling period again. Step: 1 s; Range: 0 – 600 s Note: If the IDLE function not supported on the governor, set the Idle time nevertheless to minimum 5s to avoid Underspeed possibly caused by instability of the engine short after start.

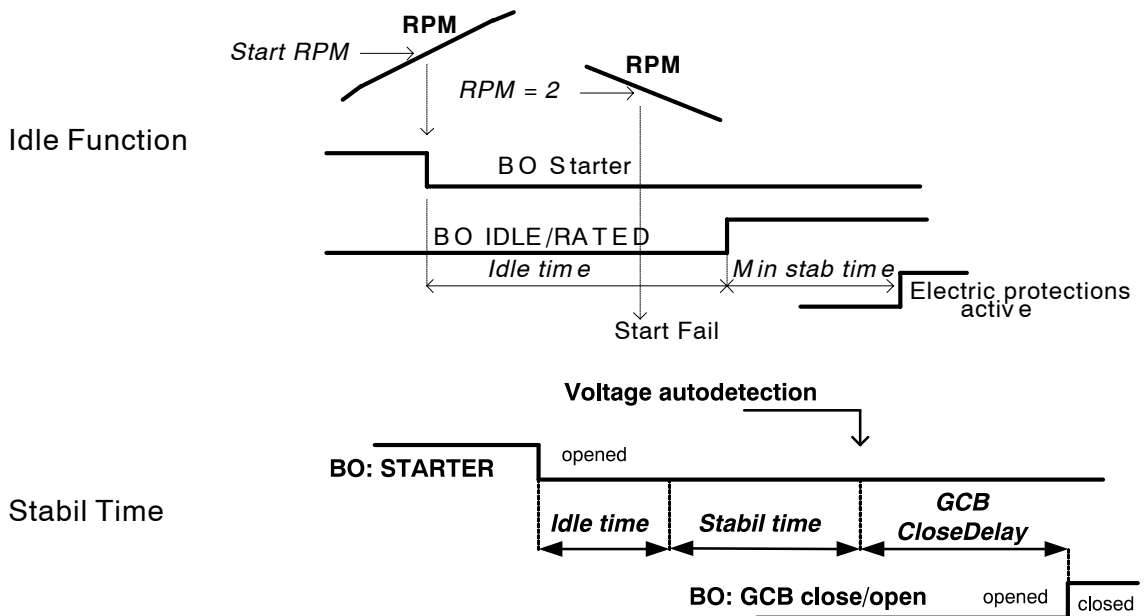

Table 4-9 Setpoints Continued



GCB CloseDelay	GCB can be closed earliest GCB CloseDelay after Stabil time when all electric values are in overunder voltage and over-under frequency limits. Step: 1 s; Range: 0 – 300 s
Stabil time	Generator Nominal voltage is detected during genset start after starter is switched off and Idle time elapses. Electric generator protections are active since detection. Step: 1 s; Range: 0 – 300 s
MinStpValvTime	Binary output Stop solenoid closes when stop sequence begins and closes at least for MinStpValvTime. Example MinStpValvTime = 20 sec. a) When engine stops (RPM=0) in 10 seconds, Binary output Stop solenoid still stays closed for 10 sec. b) When engine stops in 30 seconds, Binary output Stop solenoid opens 10 seconds after RPM=0 and Vg =0 and Oil pressure = 0. Those 10 sec is fix time for safe stop. Step: 1s; Range: 0 – 180 s Note: Stop of engine is detected when all following conditions are met: RPM =0, Oil pressure < StartingPOil and Generator voltage < 10 VAC. Stop fail is detected when is difference between those conditions, e.g RPM=O and Generator voltage > 10V.
Cooling time	Runtime of the unloaded gen-set to cool the engine before stop. Step: 1s; Range: 0 – 3600 s
D+ function	ENABLED: The D+ terminal is used for both functions   running engine  detection and charge fail detection. CHRGFAIL: The D+ terminal is used for charge fail detection only DISABLED: The D+ terminal is not used. Note: Magnetization current is independent of this setpoint value.
Eng prot del	During the start of the gen-set, some engine protections have to be blocked (e.g. Oil pressure). The protections are unblocked after the Protection del time. The time starts after reaching Start RPM. Step: 1s; Range: 0 – 300 s
Horn timeout	Max time limit of horn sounding. Set to zero if you want to leave the output HORN open. Step: 1s; Range: 0 – 600 s
Overspeed	Threshold for over speed protection. Step: 1% of nominal RPM; Range: 100 – 150%
Wrn Oil press	Warning threshold level for ANALOG INPUT 1. Step: 1 psi; Range: Sd Oil press – 10000
Sd Oil press	Shutdown threshold level for ANALOG INPUT 1. Step: 1 psi; Range: –100 – Wrn Oil press
Oil press del	Delay for ANALOG INPUT 1. Step: 1 s; Range: 0 – 180
Sd Water temp	Warning threshold level for ANALOG INPUT 2. Step: 1 °C; Range: Wrn Wtemp – 10000
Wrn Water temp	Warning threshold level for ANALOG INPUT 2. Step: 1 °F; Range: Wrn Wtemp low – Sd Water temp
Wrn Wtemp low	Warning threshold level for low value on ANALOG INPUT 2. Step: 1 °F; Range: –100 – Wrn Water temp
Water temp del	Delay for ANALOG INPUT 2 alarm. Step: 1 s; Range: 0 – 180 s
Wrn Fuel Level	Warning threshold level for ANALOG INPUT 3. Step: 1 %; Range: Sd Fuel Level – 10000
Sd Fuel Level	Shutdown threshold level for ANALOG INPUT 3. Step: 1 %; Range: –100 – Wrn Fuel Level
Fuel Level del	Delay for ANALOG INPUT 3. Step: 1 s; Range: 0 – 180 s
Batt overvolt	Warning threshold for high battery voltage. Step: 0,1 V; Range: Batt undervolt – 40V
Batt undervolt	Warning threshold for low battery voltage. Step: 0,1 V; Range: 8V – Batt overvolt
Batt volt del	Delay for low battery voltage alarm. Step: 1s; Range: 0 – 600 s
NextServTime	Counts down when engine running. If reaches zero, an alarm appears. Step: 1h; Range: 0 –65535h

Table 4-9 Setpoints Continued

Overload	Threshold for generator overload (in % of Nominal power) Step: 1% of Nominal power; Range: 0 – 200%
Overload Wrn	Threshold for generator overload warning (in % of Nominal power) Step: 1% of Nominal power; Range: 0 – 200%
Overload del	Delay for generator overload alarm. Step: 0.1s; Range: 0 – 60.0 s
Ishort	Shutdown occurs when short circuit limit Ishort limit is reached. Step: 1 % of Nominal current; Range: 100 – 500 %
2Inom del	IDMT curve shape selection. 2Inom del is Reaction time of IDMT protection for 200% overcurrent Igen = 2* Nominal current. Step: 0,1 s; Range: 0,1 – 20 s IDMT is “very inverse” generator over current protection. Reaction time is not constant but depends on generator over current level according following formula. Reaction time is limited up to 900 sec = 15 minutes. IDMT protection is not active for Reaction time values longer than 15 minutes. $\text{Reaction Time} = \frac{2\text{Inom del} * \text{Nomin current}}{\text{Igen} - \text{Nomin current}}$
Curr unbal	Threshold for generator current asymmetry (unbalance). Step: 1% of Nominal current; Range: 1 – 100% of Nominal current
Curr unbal del	Delay for generator current assymetry. Step: 0.1 s; Range: 0 – 60.0 s
Gen >V	Shutdown level for generator overvoltage. All three phases are checked. Maximum out of three is used. Step: 1% of Nominal voltage; Range: Gen >V Wrn –200%
Gen >V Wrn	Warning level for generator overvoltage. All three phases are checked. Maximum out of three is used. Step: 1% of Nominal voltage; Range: Gen <V Wrn – Gen >V
Gen <V Wrn	Warning level for generator under voltage. All three phases are checked. Minimum out of three is used. Step: 1% of Nominal voltage; Range: Gen <V – Gen >V Wrn
Gen <V	Shutdown level for generator under voltage. All three phases are checked. Minimum out of three is used. Step: 1% of Nominal voltage; Range: 0% – Gen <V Wrn
Gen V del	Delay for generator under voltage and over voltage alarm Step: 0.1s; Range: 0 – 60 s
Volt unbal	Threshold for generator voltage unbalance alarm. Step: 1% of Nominal voltage; Range: 0 – 100% of Nominal voltage
Volt unbal del	Delay for generator voltage unbalance alarm. Step: 0.1s; Range: 0 – 60.0 s
Gen >f	Shutdown level for generator over frequency. Step: 0.1% of Nominal frequency; Range: Gen > Wrn – 200.0%
Gen >f Wrn	Warning level for generator over frequency. Step: 0.1% of Nominal frequency; Range: Gen <f Wrn – Gen >V
Gen <f	Shutdown level for generator under frequency. Step: 0.1% of Nominal frequency; Range: 0.0 – Gen <f Wrn
Gen <f Wrn	Warning level for generator under frequency. Step: 0.1% of Nominal frequency; Range: Gen <f – Gen >f Wrn
Gen f del	Delay for generator under frequency and over frequency alarm. Step: 0.1s; Range: 0 – 60.0 s
Calibr AI1, AI2, AI3	Calibrating constant to adjust the measured value of IL analog inputs. Physical dimension of calibrating constant is corresponding to Analog input. Step: 1; Range: –1000 to +1000
AnOut–kW/20mA	Conversion coefficient from gen–set power to iG–IOM or PTM analog output. Step: 1; Range: 1 to 32000

Table 4-9 Setpoints Continued

AnIInIOM1 lev1	The level for IOM ANALOG INPUT 1 alarm detection. Step: 1; Range: -100 to +10000
AnIInIOM1 lev2	The level for IOM ANALOG INPUT 1 alarm detection. Step: 1; Range: -100 to +10000
AnIInIOM1 del	Delay for IOM ANALOG INPUT 1 alarm. Step: 1 s; Range: 0 - 180 s
AnIInIOM2 lev1	The level for IOM ANALOG INPUT 2 alarm detection. Step: 1; Range: -100 to +10000
AnIInIOM2 lev2	The level for IOM ANALOG INPUT 2 alarm detection. Step: 1; Range: -100 to +10000
AnIInIOM2 del	Delay for IOM ANALOG INPUT 2 alarm. Step: 1 s; Range: 0 - 180 s
AnIInIOM3 lev1	The level for IOM ANALOG INPUT 3 alarm detection. Step: 1; Range: -100 to +10000
AnIInIOM3 lev2	The level for IOM ANALOG INPUT 3 alarm detection. Step: 1; Range: -100 to +10000
AnIInIOM3 del	Delay for IOM ANALOG INPUT 3 alarm. Step: 1 s; Range: 0 - 180 s
AnIInIOM4 lev1	The level for IOM ANALOG INPUT 4 alarm detection. Step: 1; Range: -100 to +10000
AnIInIOM4 lev2	The level for IOM ANALOG INPUT 4 alarm detection. Step: 1; Range: -100 to +10000
AnIInIOM4 del	Delay for IOM ANALOG INPUT 4 alarm. Step: 1 s; Range: 0 - 180 s The protection of IOM/PTM inputs is activated by over crossing the limits.
Calibr AIInIOM 1..4	Calibrating constant to adjust the measured value of IOM/PTM analog inputs. Physical dimension of calibrating constant is corresponding to Analog input. Step: 1; Range: -1000 to +1000

Figure 4-9 Controller Connection Diagram

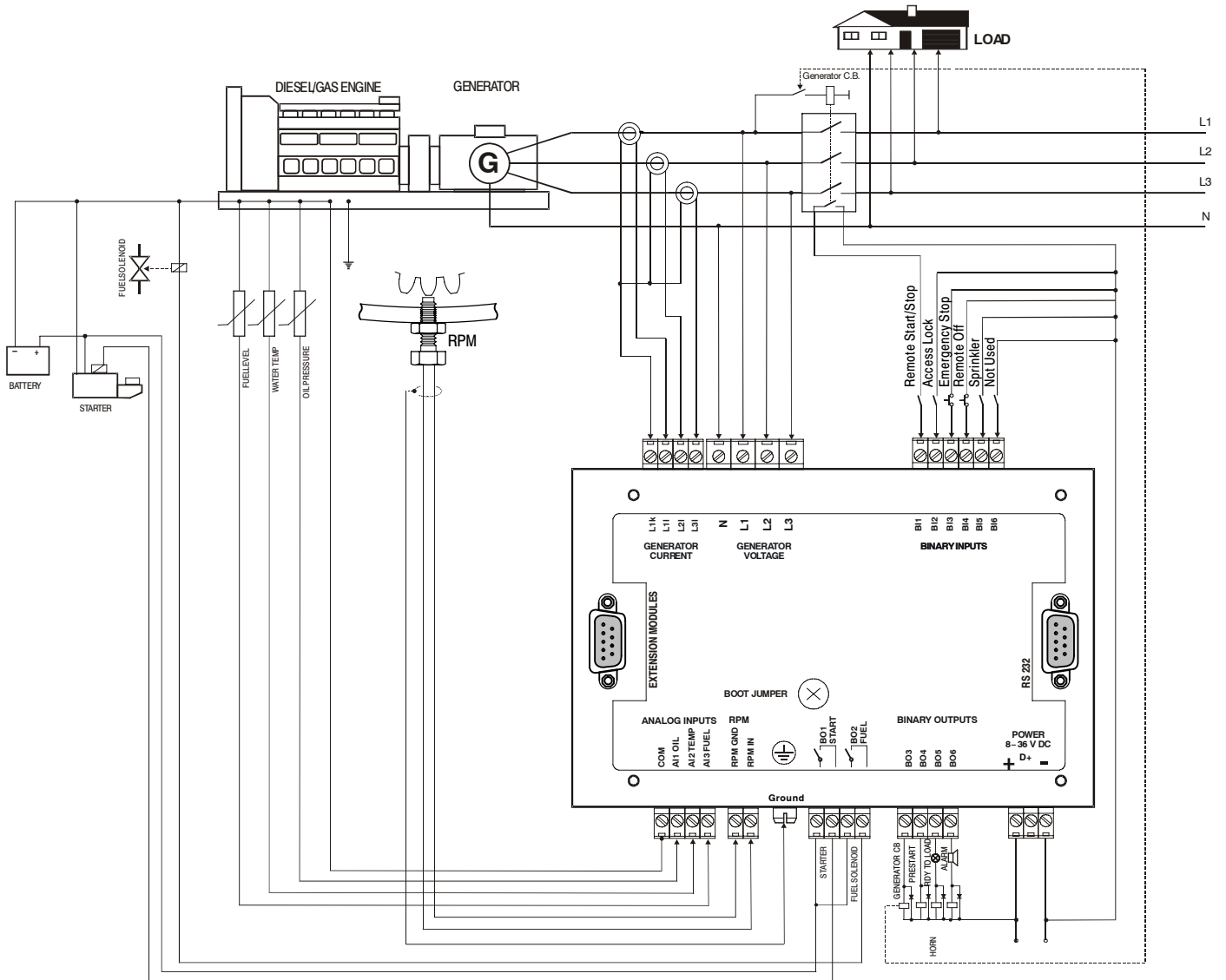

Digital Engine Controller Description EM0046A21 (MRS17) Continued
Figure 4-10 Controller Connection Diagram

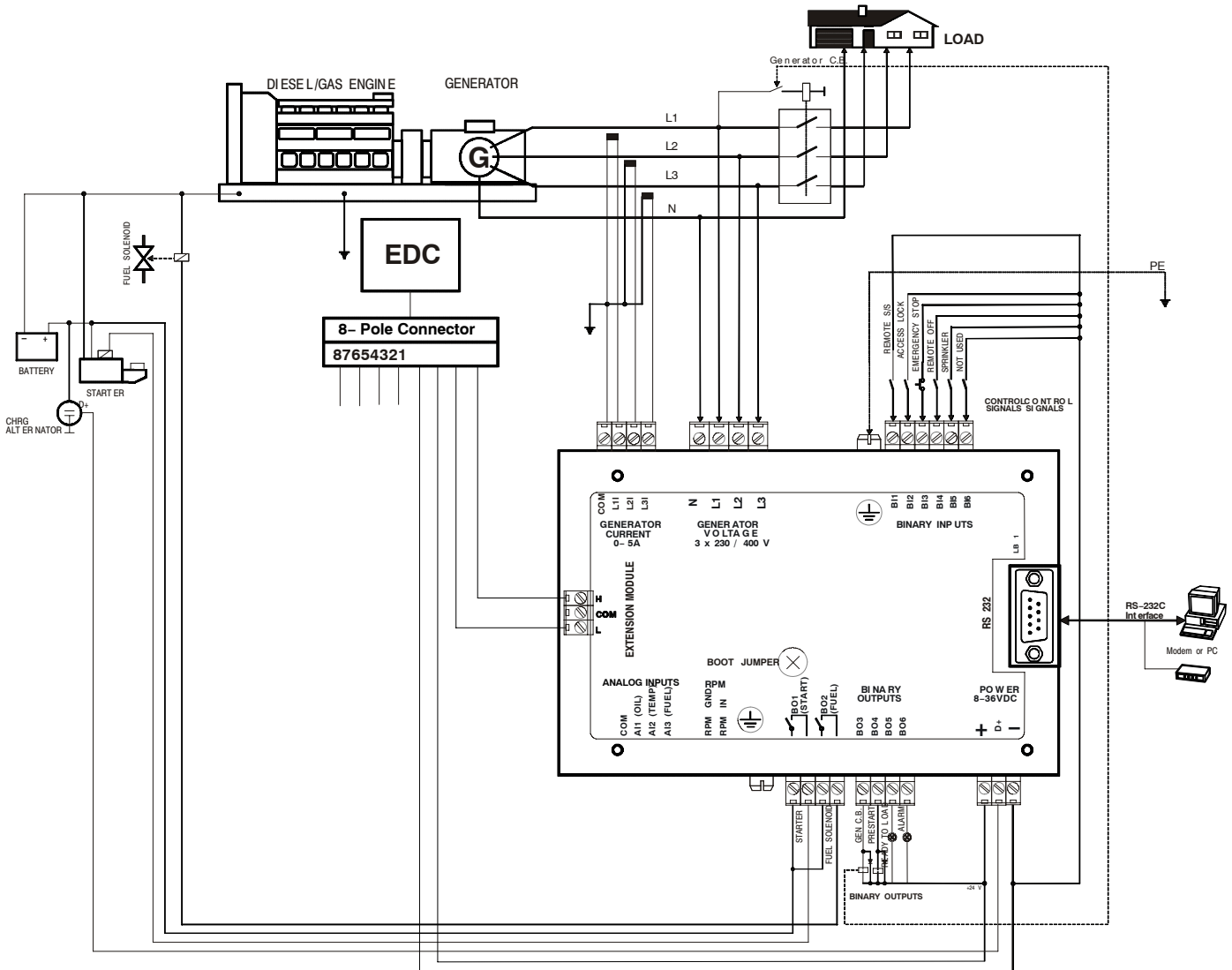

Section 5

Troubleshooting and Maintenance

WARNING: Never “jump start” a generator to start the engine. If the battery charge is insufficient to start the engine, charge or replace the battery and try to restart. Jump starting a battery can cause the battery to explode and cause severe injury or death to anyone in the area.

Caution: If a dead battery is suspected charge battery (or replace), and then attempting starting. Damage to engine control may result from jump starting.

Maintenance

This manual contains only very minimal engine maintenance instructions. Refer to the engine manufacturer’s owner’s manual for specific engine maintenance instructions for your generator set. Any maintenance instructions or recommendations in the engine owner’s manual take precedence over any of the following general recommendations.

General:

1. Inspect the fuel system for leaks. Replace all defective components immediately.
2. Inspect and replace any fuel line that shows signs of deterioration.
3. Inspect all the fuel clamps to ensure they are tight.
4. Make sure the fuel cap fits snugly on the fuel tank and that the fuel tank contains no leaks.
5. Inspect and clean the battery posts and the associated battery cable terminals.
6. Inspect the external wire cables and connectors used with the generator set for cuts, fraying, or loose connections. Repair or replace any problems prior to using the unit.

Engine:

1. Clean and/or replace any fuel, oil, and/or air filters per the engine manufacturers’ guidelines.
2. Check oil level regularly; at least every 5 to 8 operating hours. Maintain the proper oil level.
3. Change the oil as is recommended in the engine manufacturer’s owner’s manual.
4. Clean the cooling fins on the engine to keep the engine’s heat dissipation potential at it’s maximum.
5. Inspect and clean all governor and fuel supply linkages so they operate properly.

Alternator: (also called Generator End)

This generator set must be run at its proper speed to obtain the correct electrical power at its output. All engines have a tendency to slow down when a load is applied to it. The engine governor is designed to hold the operating speed as nearly constant as possible. When the electrical load is increased, the engine is more heavily loaded and engine speed drops slightly. This slight decrease in engine speed results in a slight decrease in generator voltage and frequency output. This voltage and frequency variation has no appreciable effect in the operation of motors, lights, and most appliances and tools. However, timing devices and clocks may not keep perfect time.

1. Clean the generator set and remove any and all dust, dirt, or other foreign material.
2. Inspect and clean the cooling air intake and exhaust louvers of the generator end. Make sure they are clean. Remove dirt or any buildup that may restrict the cooling air flow.
3. Clean the generator set and its components with a damp cloth or sponge. Never use a water hose or pressure washer as this may damage electrical components.
4. Inspect and replace any control panel components that are broken or not working properly (receptacles, circuit breakers, switches, etc.)

Problems and Solutions

Some of the more common problems are listed in Table 5-1. This information is intended to be a check or verification that simple causes can be located and fixed. It is not an exhaustive “how to” for all types of problems. Procedures that require in depth knowledge or skills (like flashing the field) should be referred to an authorized service department.

Table 5-1 Troubleshooting Guide

Problem	Possible Cause	Remedy
Engine will not start	No fuel. Restricted air flow. Damaged glow plug	Check that fuel valves are ON. Check fuel level in fuel tank. Check/replace air filter. Check/replace glow plug(s). Check that engine switch is in Start position.
Engine will not crank	Dead battery.	Remove battery and trickle charge or replace with new battery. Never Jump Start.
Engine starts but will not run smoothly	Fuel or ignition problem	Refer to engine manual.
Engine overheats	Excessive load Debris or dirt buildup on engine Low Coolant Level	Remove one or more electrical loads. Remove debris. Clean engine surfaces to allow cooling. Replenish coolant
Output voltage varies	Irregular speed Fluctuating speed Loose terminal or load connections Defective alternator bearing (uneven air gap)	Check engine for malfunction or load for fluctuation Stabilize load. The addition of a lamp load (resistance load) may compensate partially for load changes caused by intermittent motor operation. Do not overload. Verify all connections are proper and check tightness torque of terminals. Replace worn bearing
Low Voltage (0–15 VAC output)	Bad Voltmeter Bad/Open Circuit Breaker/Fuse Bad Connection Loss of Residual Magnetism Bad Voltage Selector Switch Bad Stator Windings	Measure the voltage across the voltage meter with an accurate voltmeter to verify. Check continuity across Breaker/Fuse. Replace if defective. Check wiring including grounds, crimps and connection points. Repair defects. The generator needs to be flashed. Contact service center to perform this procedure. Replace switch, contact service center to perform this procedure. Contact service center to perform this procedure.
Low Voltage (15–20 VAC output)	Bad Voltmeter Incorrect Engine Speed Bad/Open Circuit Breaker/Fuse Bad Connection Bad Voltage Selector Switch Bad Stator Windings Bad Voltage Adj. Rheostat Bad Voltage Regulator Bad Rotor Diodes Bad Rotor Windings	Measure the voltage across the voltage meter with an accurate voltmeter to verify. Remove electrical load, output should be 61–62 Hertz adjust engine speed if necessary. Check continuity across Breaker/Fuse. Replace if defective. Check wiring including grounds, crimps and connection points. Repair defects. Replace switch, contact service center to perform this procedure. Contact service center to perform this procedure. Replace rheostat, contact service center to perform this procedure. Replace regulator, contact service center to perform this procedure. Contact service center to perform this procedure. Contact service center to perform this procedure.
Incorrect voltage output	Bad Voltmeter Incorrect Engine Speed Bad Voltage Adj. Rheostat Bad Voltage Regulator Bad Connection Bad Voltage Selector Switch	Measure the voltage across the voltage meter with an accurate voltmeter to verify. Remove electrical load, output should be 61–62 Hertz adjust engine speed if necessary. Replace rheostat, contact service center to perform this procedure. Replace regulator, contact service center to perform this procedure. Check wiring including grounds, crimps and connection points. Repair defects. Replace switch, contact service center to perform this procedure.
High output voltage	Excessive speed	Check engine for malfunction

Table 5-1 Troubleshooting Guide Continued

Problem	Possible Cause	Remedy
Genset will not pull load	Incorrect Engine Speed	Remove electrical load, output should be 61–62 Hertz adjust engine speed if necessary.
	Load not connected properly	Verify voltage at the load and the connections to the proper receptacle or load terminal block.
	Load too large for unit	Verify load amperage is less than the generator set rated. Note: For inductive loads, use the starting amperage rating of the load (not the running amperage rating). Starting amps may be as much as 5 times the running amps.
Electrical shock when frame is touched	Static charge. Grounded armature or field coil.	Ground generator frame at local reference ground (see Section 3). Contact service center.
Mechanical noise (alternator)	Defective bearing	Replace bearing.
	Rotor rubbing on stator	Bad bearing – replace. Bent shaft – contact service center. Loose end bell – tighten; Loose drive Discs – tighten
	Loose or misaligned coupling	Tighten; align coupling and alternator shaft to engine shaft.
Trailer lights inoperable	Trailer to tow vehicle connection	Connect trailer lighting connector to tow vehicle trailering connector
	Trailer electrical connection not compatible	Use adapter plug to convert from connector style found on trailer to connector style found on tow vehicle or replace connector with compatible mate
	Insufficient Ground connection	Verify there is a ground wire connection from the tow vehicle to the trailer. Do not rely on the trailer tow coupling for the battery ground connection. Repair as necessary.
	Faulty light bulb	Replace as necessary
Trailer sways during towing	Tow vehicle trailering ratings too small	Check tow vehicle ratings meet or exceed the Gross Vehicle Weight Rating (GVWR) of the trailer. Use larger tow vehicle as necessary. Seek expert advise.
	Trailer tongue not level on tow vehicle	Adjust trailer or tow vehicle as necessary for trailer tongue to be level or slightly higher than rear of tow vehicle when additional supports have been removed. View and make adjustments while vehicle and trailer are on level surface. Seek expert advise.
	Towing at excessive speed	Reduce tow vehicle speed and use caution while braking. Obey all local laws and regulations, never exceed the posted speed limit, and use reasonable care when towing any type of trailer. Contact local authority having jurisdiction.

Note: After the engine is stopped, there is a 15 second restart delay before engine cranking.

Fault Shutdowns Under certain operating conditions, onboard sensors determine that a condition may cause damage if operation continues. The onboard controller is programmed to sound an alarm or immediately stop (shutdown) the generator. These conditions are as follows:

1. An alarm fault is indicated by an alarm light located on the operator panel:
 - a. Overspeed – indicates the engine governor allowed speed to exceed safe limits.
 - b. Overcrank – indicates engine failed to start within programmed time period.
 - c. Low Oil Pressure – Safe engine operating oil pressure was not maintained.
 - d. Overtemperature – indicates safe operating coolant temperature was exceeded.
2. Engine cannot be restarted until the alarm condition is corrected.
3. Reset the alarm condition (after alarm condition is corrected) by pressing “Reset”.
Operation can be attempted, observe the operator panel when operation is resumed to ensure alarm condition is removed.

Overload When maximum current output exceeds the output breaker limit, the main breaker will trip. When this occurs, the load must be reduced and the breaker reset before operation can be resumed.

Note: The Main Breaker cannot be reset if load connection box door is open. This door must be closed before the breaker can be reset to connect the electrical load.

Service & Parts Service and parts for your generator can be obtained from an authorized service center. Please have the following information available prior to contacting the service center:

The model number and serial number of the generator set.

A complete and accurate description of the part (part number if known).

Note: Engine parts can usually be obtained from a local distributor by using the information in the engine manufacturer’s owner’s manual.

Appendix A

Wiring Diagrams

Replacement Parts Replacement parts information is provided in Replacement Parts Catalog CA2401.
Engine parts are identified in the engine manual that was provided with your generator set.

IMPORTANT: **Fuses are installed in the control box to protect the engine controller and associated control circuits. When replacing fuses, use the exact replacement fuse (manufacturer and part number).**

Wiring Diagrams Wiring diagrams for these generators are contained on the following pages of this appendix.

Figure A-1 TS25 Connection Diagram

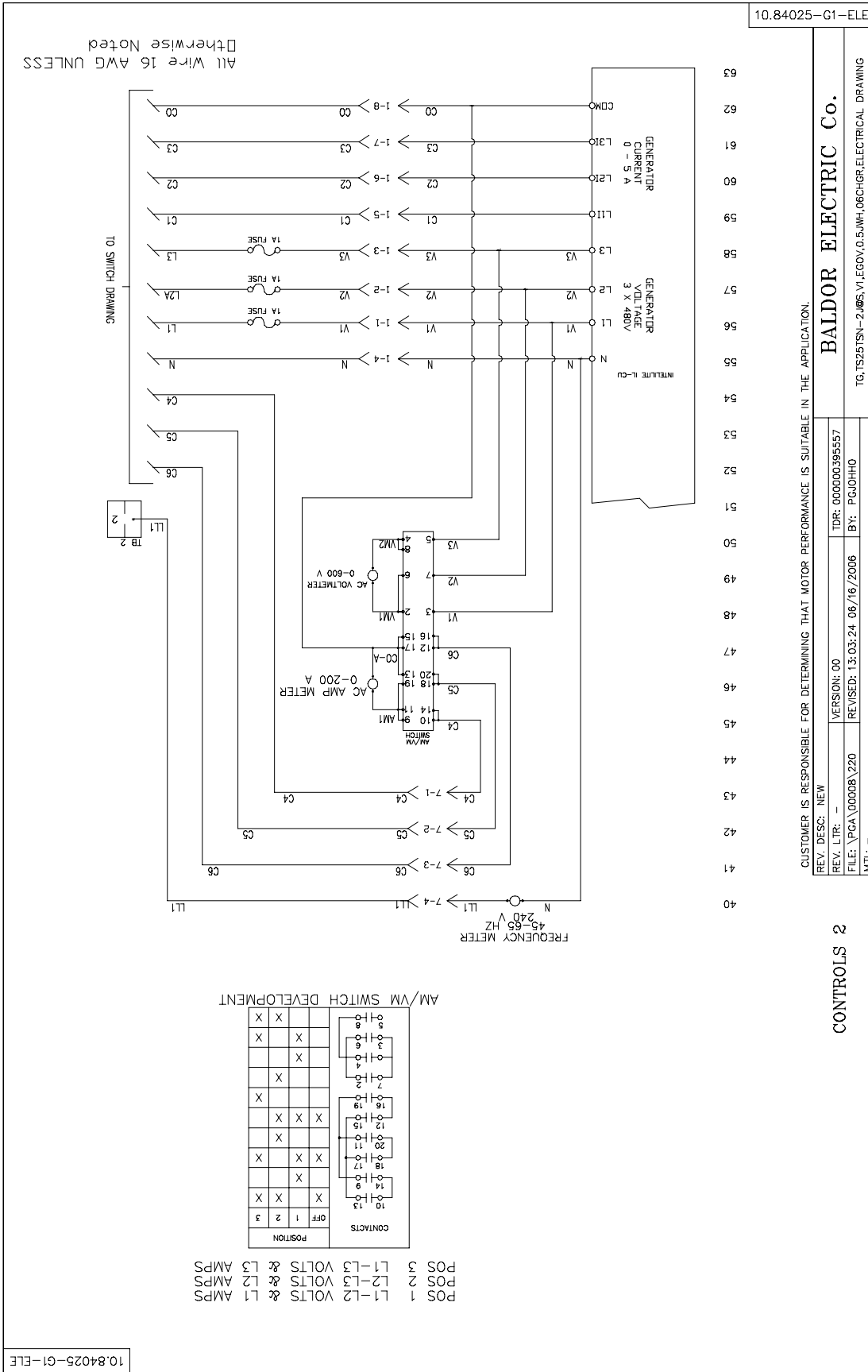

10.84025-G1-ELE

CUSTOMER IS RESPONSIBLE FOR DETERMINING THAT MOTOR PERFORMANCE IS SUITABLE IN THE APPLICATION.

REV. DISC: NEW	VERSION: 00	TDR: 000000395557
REV. LTR: -	FILE: \P3A\00008\220	BY: PGJ0HHG
REVISED: 13:03:24 06/16/2006	TG: TS25TSN-2.065.V1.EG0V.0.5.WH.06CHGR.ELECTRICAL DRAWING	
MFL: -		

CONTROLS 2

AM/VM SWITCH DEVELOPMENT

POSITION	OFF	1	2	3
POS 1	X	X	X	X
POS 2	X	X	X	X
POS 3	X	X	X	X

POS 1 L1-L2 VOLTS & L1 AMPS
 POS 2 L2-L3 VOLTS & L2 AMPS
 POS 3 L1-L3 VOLTS & L3 AMPS

10.84025-G1-ELE

Figure A-2 TS25 Connection Diagram

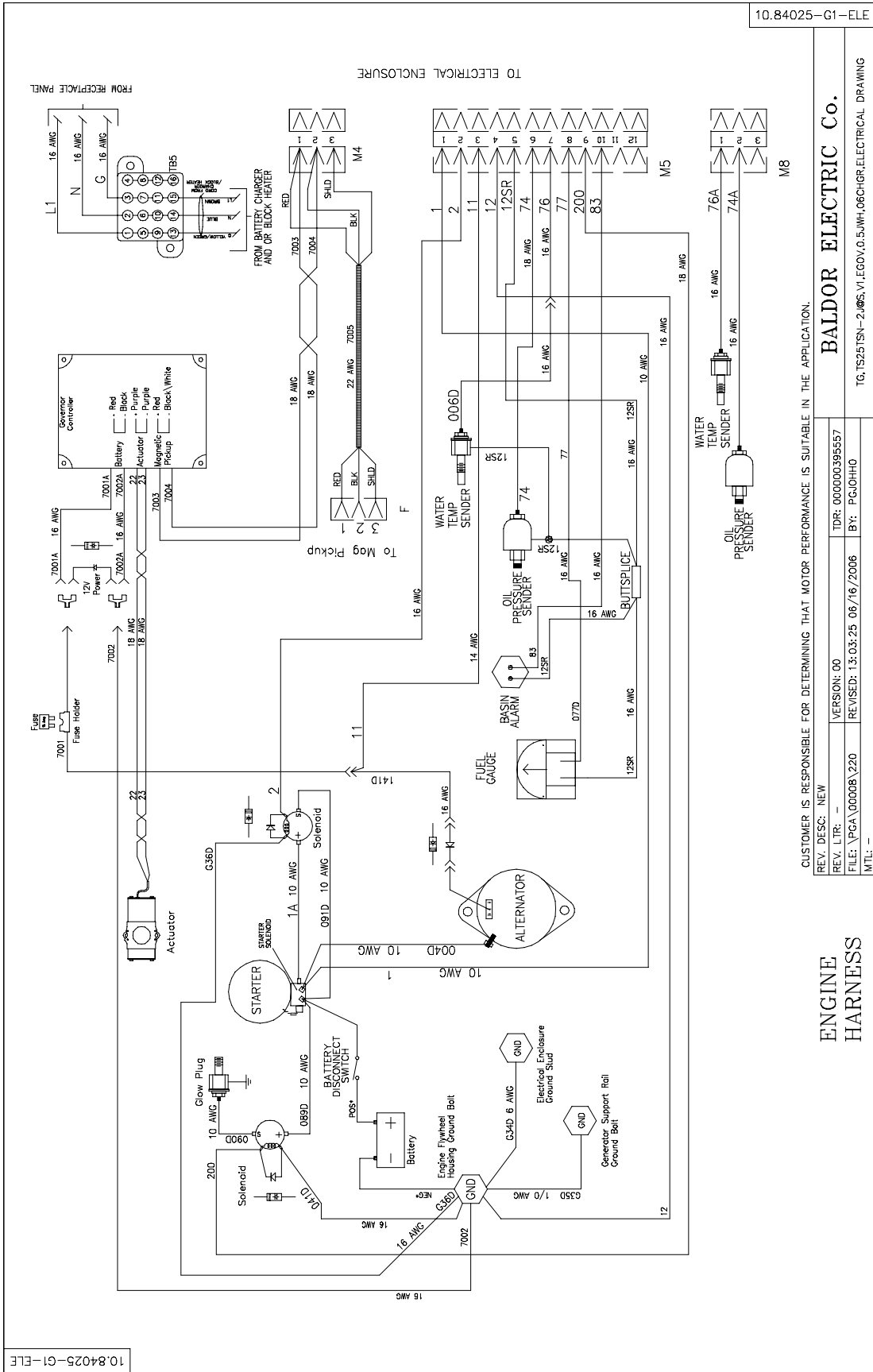

10.84025-G1-ELE

10.84025-G1-ELE

CUSTOMER IS RESPONSIBLE FOR DETERMINING THAT MOTOR PERFORMANCE IS SUITABLE IN THE APPLICATION.

REV. LTR:	VERSION: 00	TDR: 000000.395557
FILE: \PSA\00008\220	REVISED: 13.03.25 06/16/2006	BY: PG:OJHO
MFL:		

**ENGINE
HARNES**

BALDOR ELECTRIC Co.

TG:TS25TSN-2,0CS,V1,EGOV,0.5,WH,06CHGR,ELECTRICAL DRAWING

Figure A-3 TS25 Connection Diagram

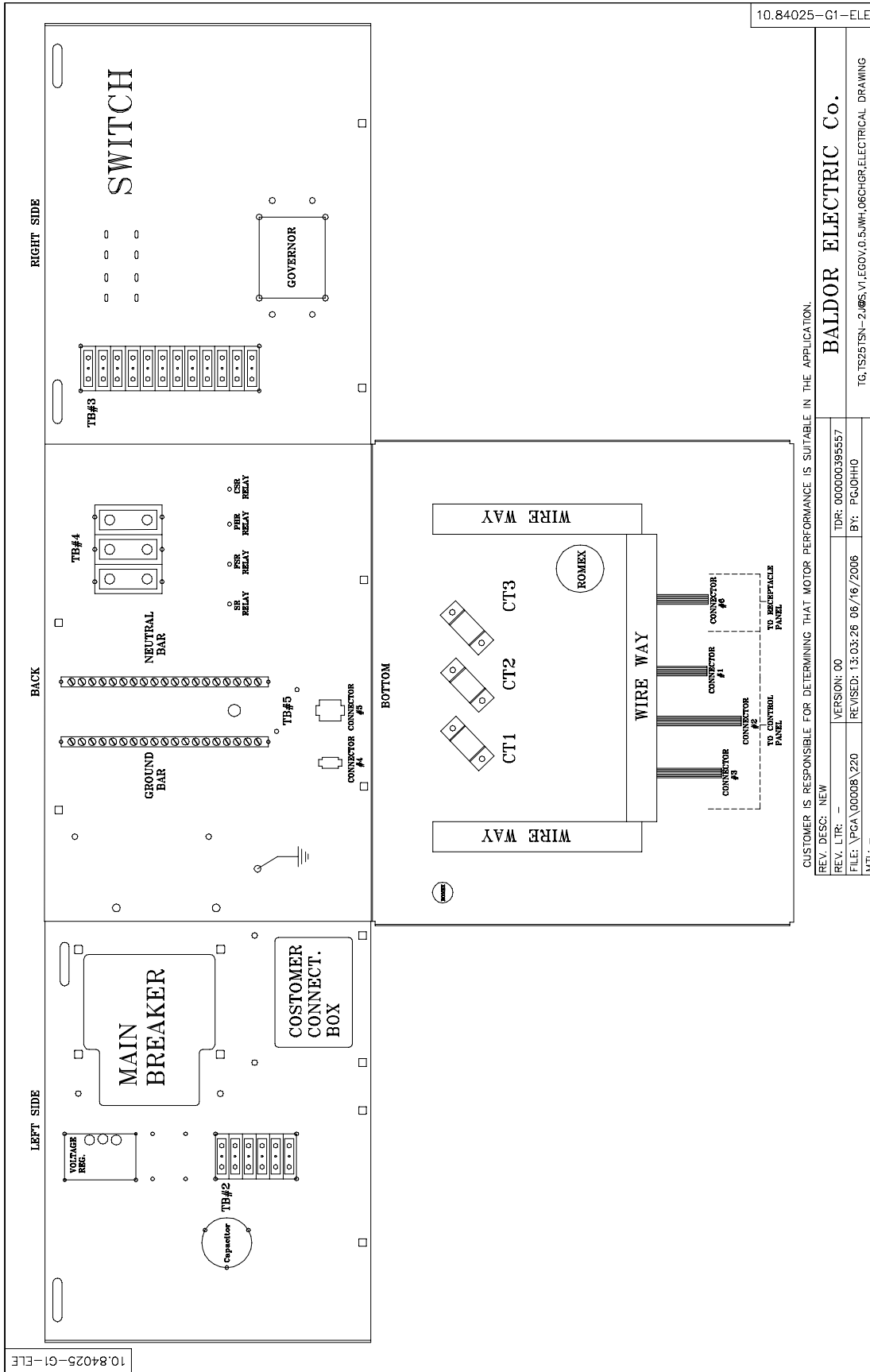

10.84025-G1-ELE

10.84025-G1-ELE

CUSTOMER IS RESPONSIBLE FOR DETERMINING THAT MOTOR PERFORMANCE IS SUITABLE IN THE APPLICATION.

REV. DESC: NEW	VERSION: 00	TDR: 000000395557
REV. LTR: -	REVISED: 13:03:26 06/16/2006	BY: PG,OHG
FILE: \PGA\00008\220		
MFL: -		

BALDOR ELECTRIC Co.

TG-TS25TSN-2.05S.V1.EGOV.D.5.WH.06CHGR.ELECTRICAL DRAWING

Figure A-4 TS25 Connection Diagram

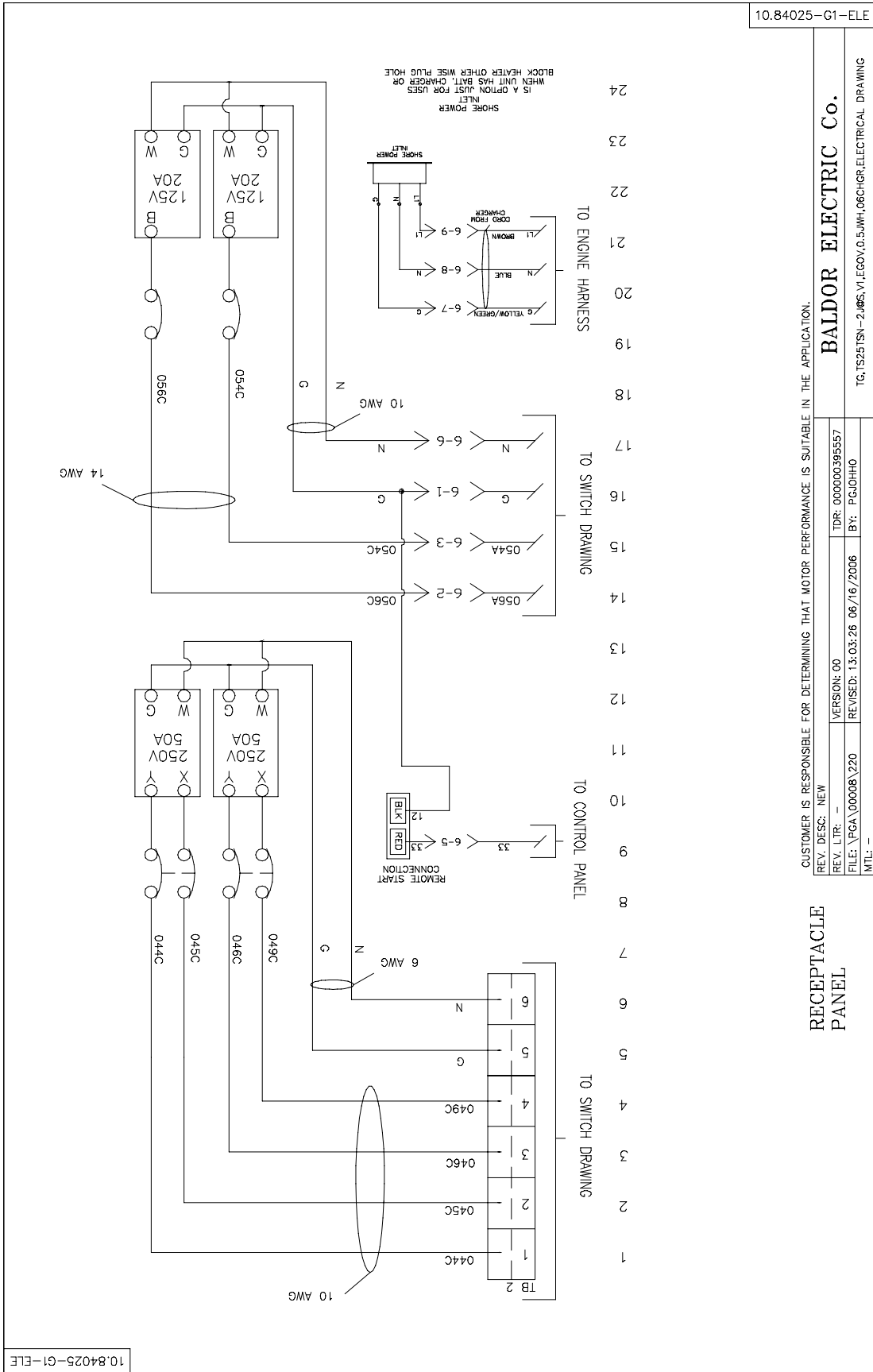
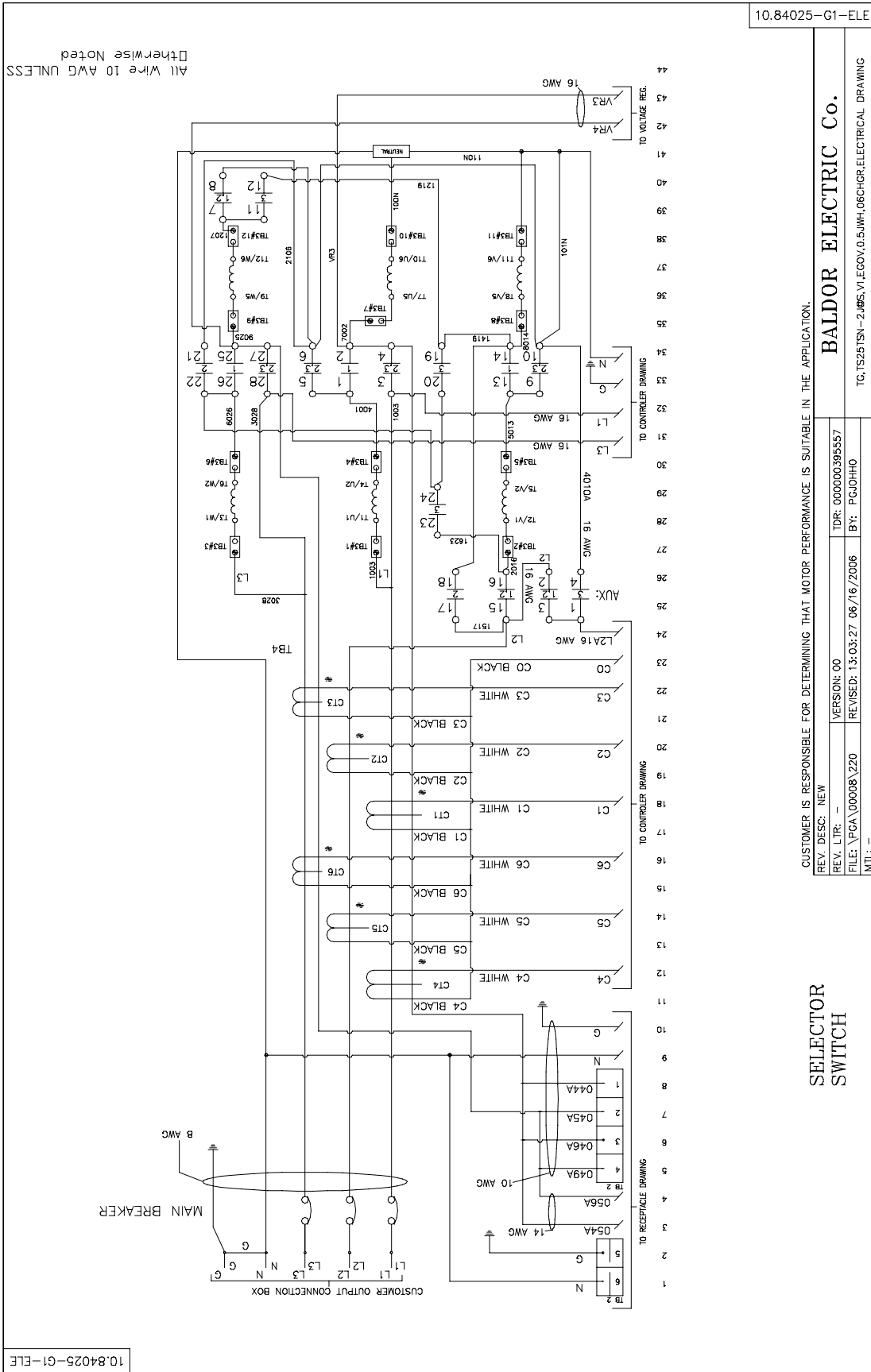

Figure A-5 TS25 Connection Diagram



10.84025-G1-ELE

CUSTOMER IS RESPONSIBLE FOR DETERMINING THAT MOTOR PERFORMANCE IS SUITABLE IN THE APPLICATION.

REV. DESC: NEW		VERSION: 00	
REV. LTR: -		TDR: 000000395557	
FILE: \PGA\00008\220		REVISED: 13-03-27 06/16/2006	
MPL: -		BY: PGJHHG	

SELECTOR SWITCH

BALDOR ELECTRIC Co.

TC: TS25TSN-2.06S.V1.ECOV.0.5MWH.06CHGR.ELECTRICAL DRAWING

10.84025-G1-ELE

Figure A-6 TS25 Connection Diagram

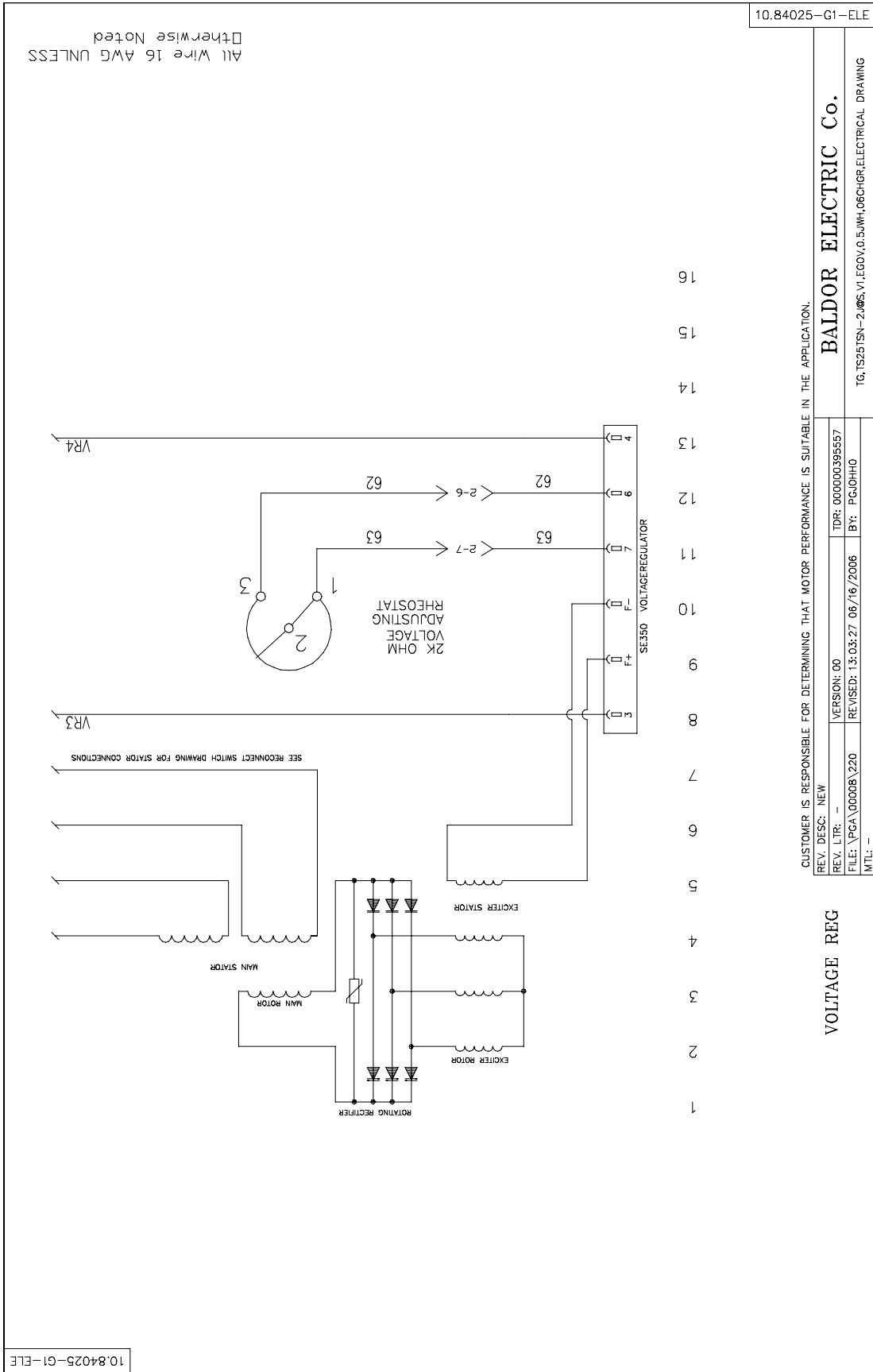
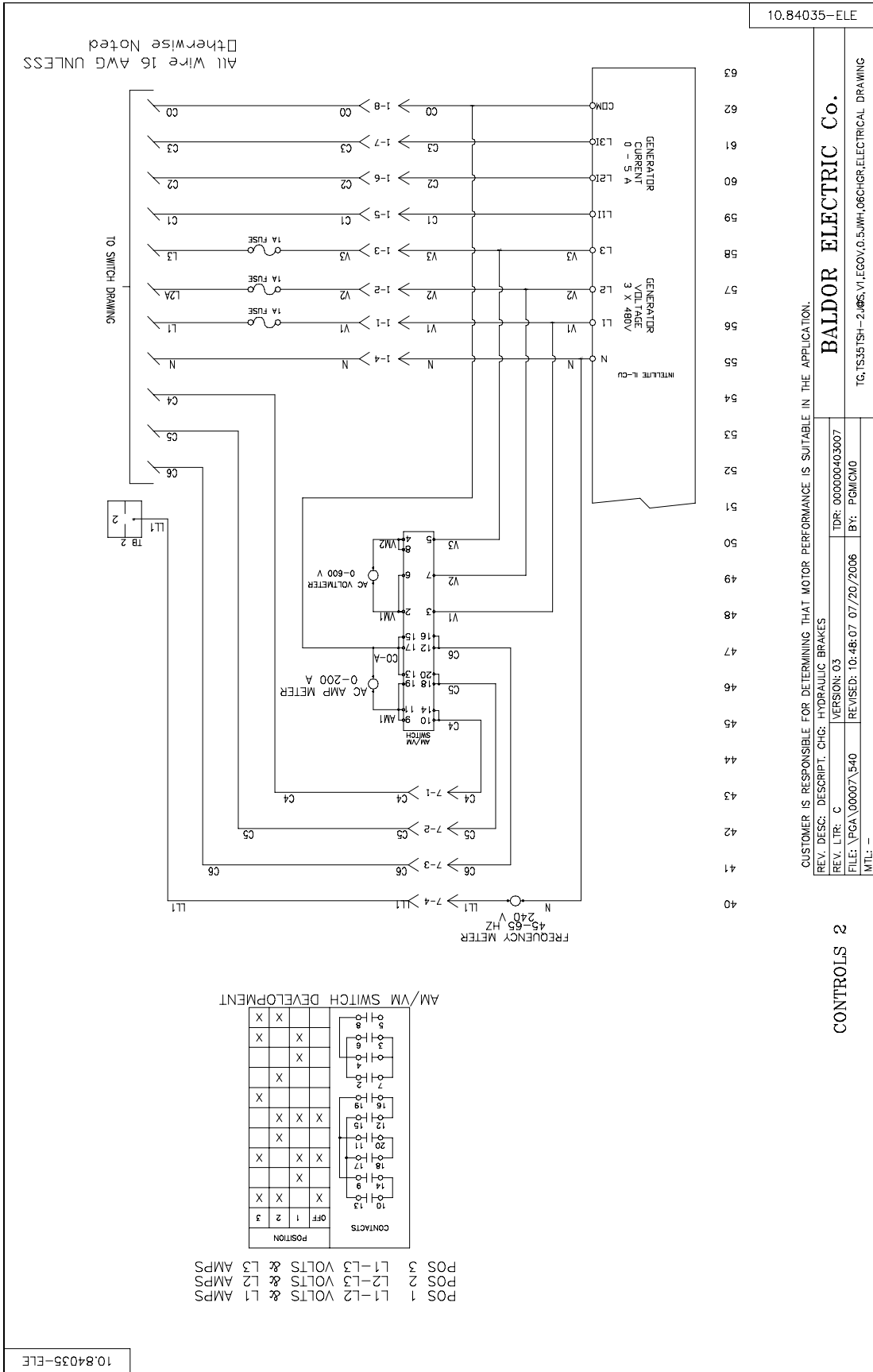

Figure A-8 TS35 Connection Diagram



All wire 16 AWG UNLESS
 otherwise Noted

10.84035-ELE

40
41
42
43
44
45
46
47
48
49
50
51
52
53
54
55
56
57
58
59
60
61
62
63

AM/VM SWITCH DEVELOPMENT

CONTRACTS	POSITION	1	2	3
10-13	OFF		X	
14-9		X	X	X
15-10		X		
16-11		X	X	X
17-12		X		
18-13		X	X	X
19-14		X		
20-15		X	X	X
21-16		X		
22-17		X	X	X
23-18		X		
24-19		X	X	X
25-20		X		
26-21		X	X	X
27-22		X		
28-23		X	X	X
29-24		X		
30-25		X	X	X
31-26		X		
32-27		X	X	X
33-28		X		
34-29		X	X	X
35-30		X		

POS 1 L1-L2 VOLTS & L1 AMPS
 POS 2 L2-L3 VOLTS & L2 AMPS
 POS 3 L1-L3 VOLTS & L3 AMPS

CUSTOMER IS RESPONSIBLE FOR DETERMINING THAT MOTOR PERFORMANCE IS SUITABLE IN THE APPLICATION.

BALDOR ELECTRIC Co.

TDR: 000000403007
 BY: PGMICMO

REV. LTR: C
 VERSION: 03

REVISED: 10-48-07 07/20/2006
 FILE: \PGA\00007\340

MTL: -

CONTROLS 2

10.84035-ELE

Figure A-9 TS35 Connection Diagram

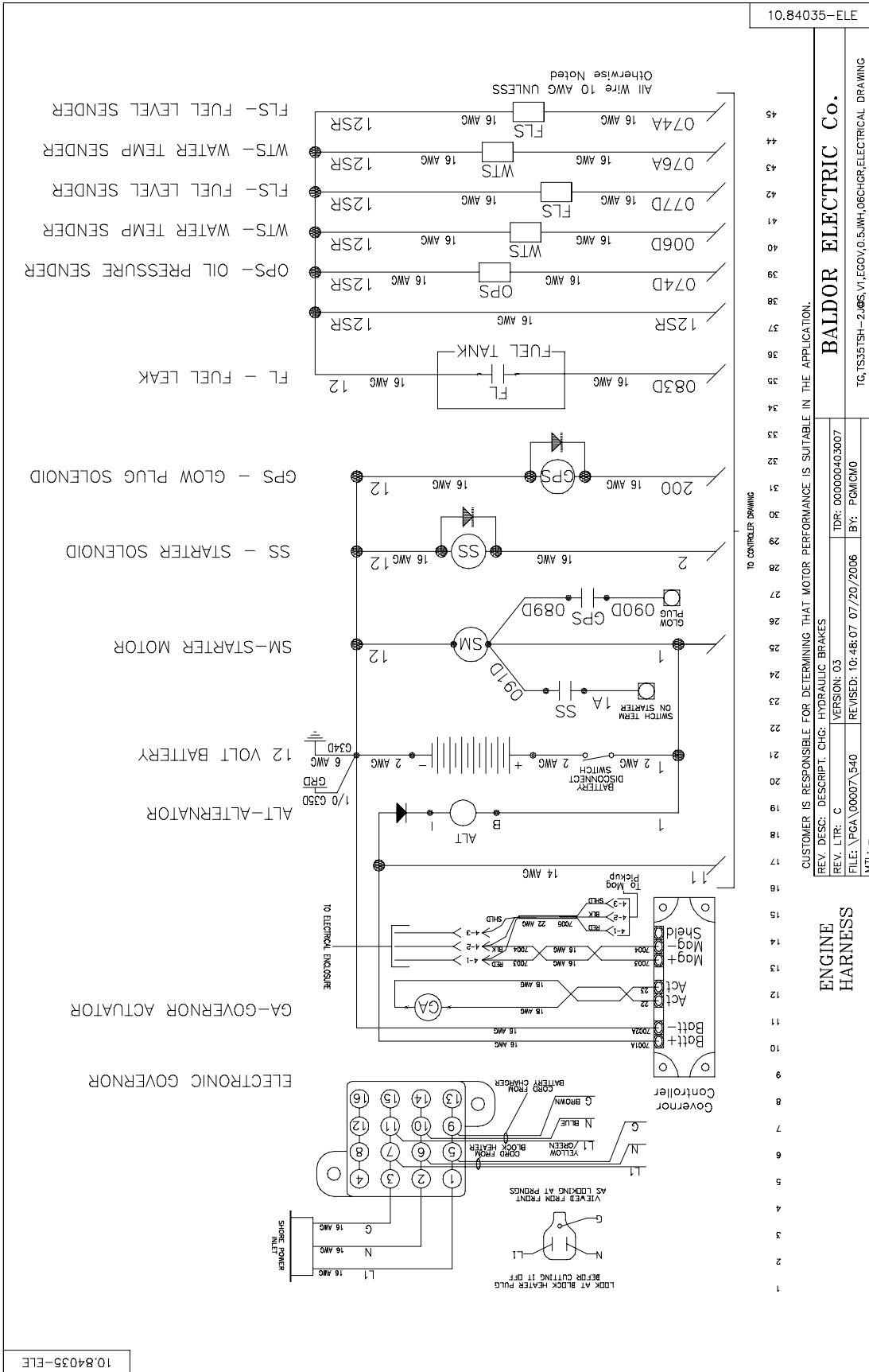
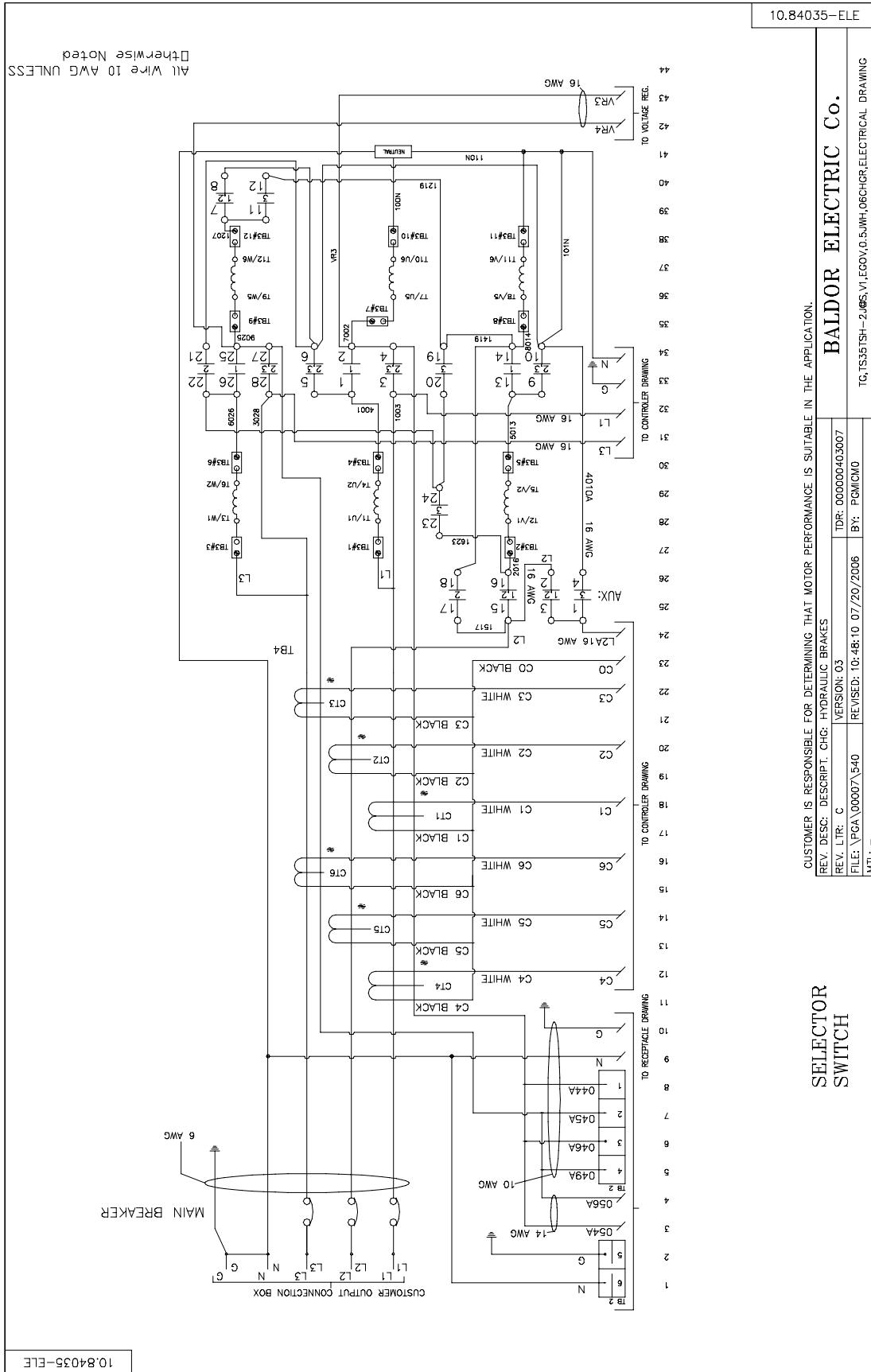

Figure A-11 TS35 Connection Diagram



10.84035-ELE

10.84035-ELE

CUSTOMER IS RESPONSIBLE FOR DETERMINING THAT MOTOR PERFORMANCE IS SUITABLE IN THE APPLICATION.

REV. DESC: CHG: HYDRAULIC BRAKES
 REV. LTR: C
 FILE: \PGA\00007\540
 MTL: -

SELECTION SWITCH

BALDOR ELECTRIC Co.

TDR: 00000403007
 BY: PGM/CMG

TO VOLTAGE REG.
 TO CONTROLLER DRAWING
 TO RECEPTACLE DRAWING
 TO CONTROLLER DRAWING

TO VOLTAGE REG.
 TO CONTROLLER DRAWING
 TO RECEPTACLE DRAWING
 TO CONTROLLER DRAWING

TO VOLTAGE REG.
 TO CONTROLLER DRAWING
 TO RECEPTACLE DRAWING
 TO CONTROLLER DRAWING

TO VOLTAGE REG.
 TO CONTROLLER DRAWING
 TO RECEPTACLE DRAWING
 TO CONTROLLER DRAWING

TO VOLTAGE REG.
 TO CONTROLLER DRAWING
 TO RECEPTACLE DRAWING
 TO CONTROLLER DRAWING

TO VOLTAGE REG.
 TO CONTROLLER DRAWING
 TO RECEPTACLE DRAWING
 TO CONTROLLER DRAWING

Figure A-12 TS35 Connection Diagram

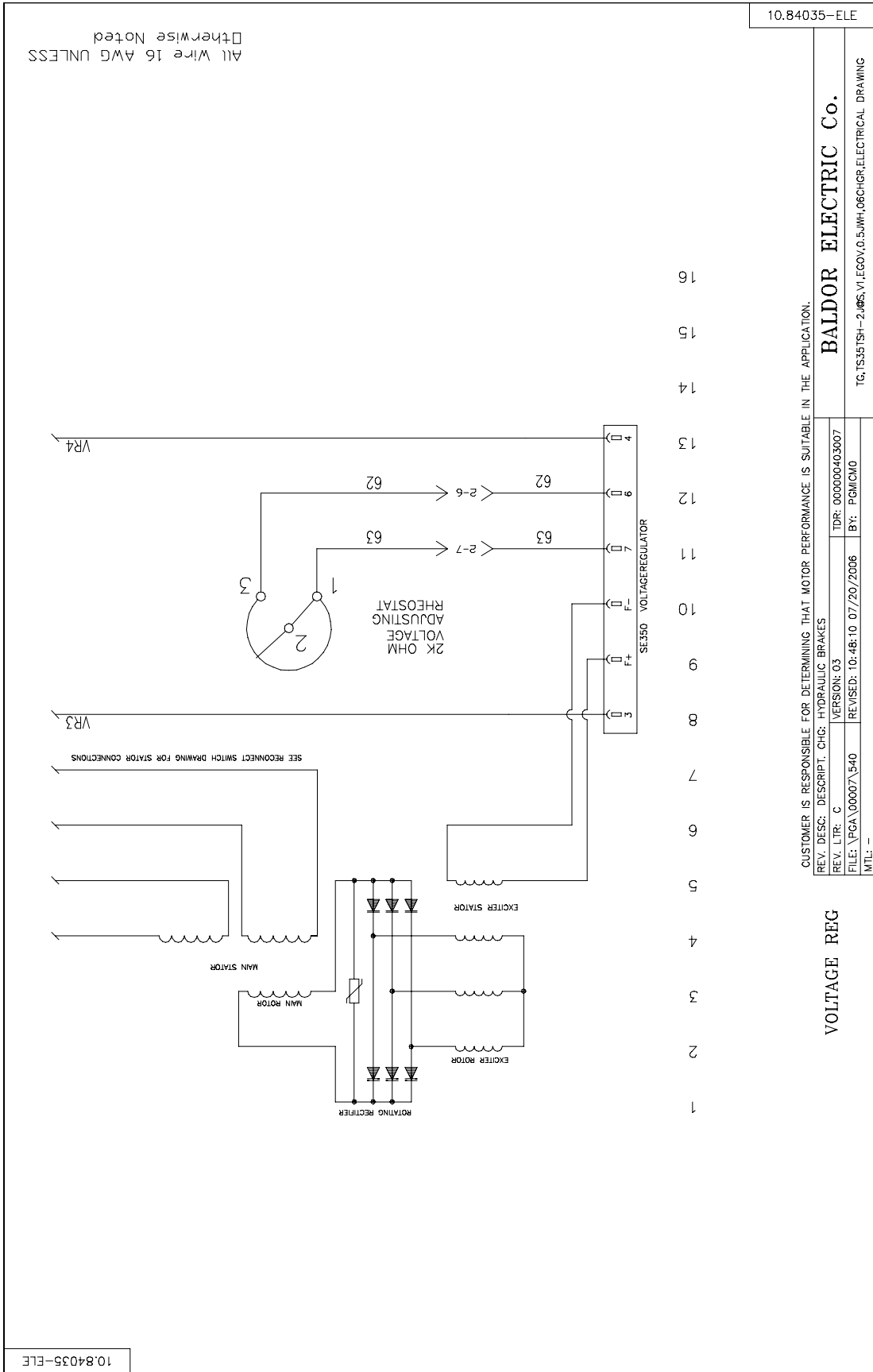
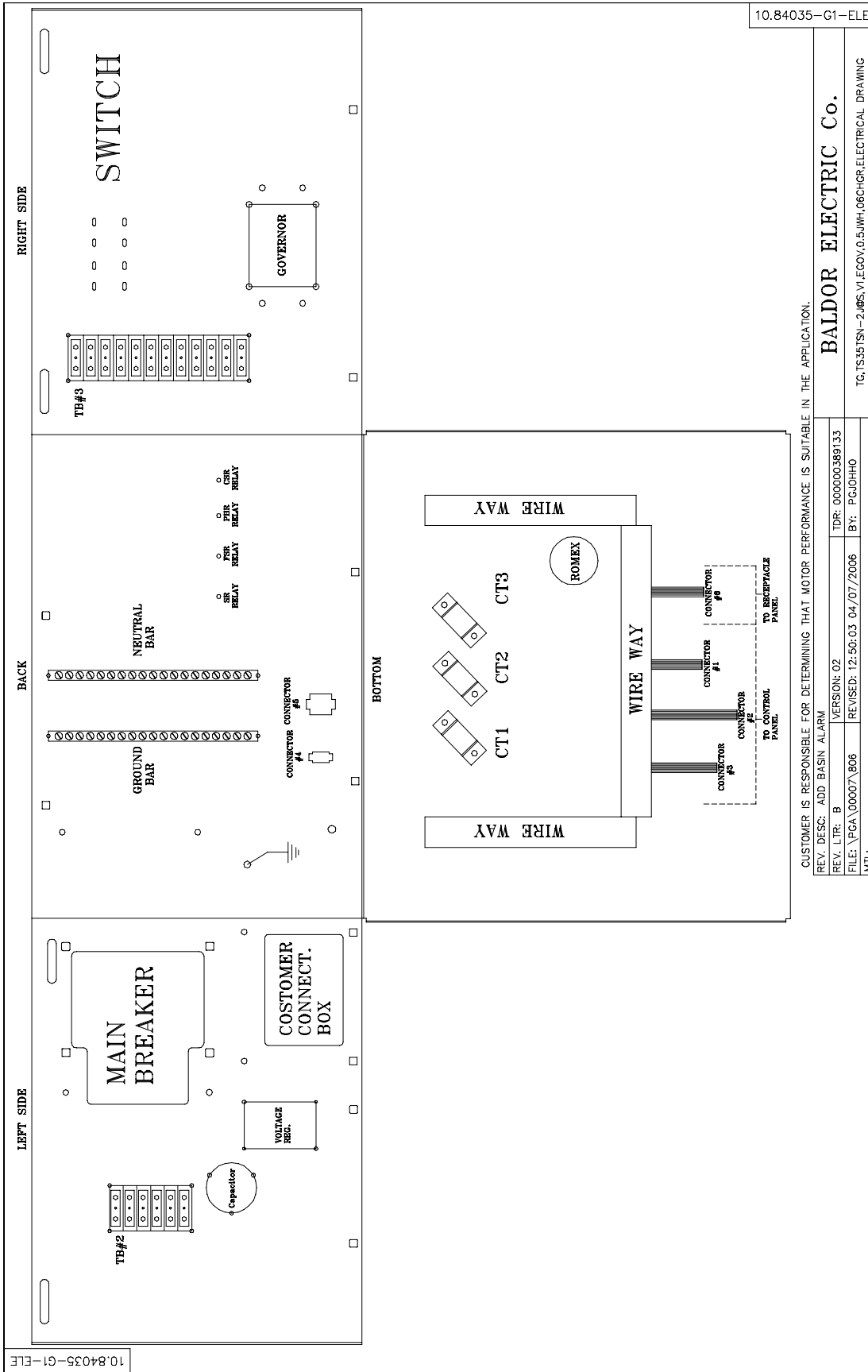

Figure A-13 TS35 Power Connection Diagram



CUSTOMER IS RESPONSIBLE FOR DETERMINING THAT MOTOR PERFORMANCE IS SUITABLE IN THE APPLICATION.

REV. DESC: ADD BASIN ALARM	VERSION: 02	TDR: 000000389133
REV. LTR: B	REVISED: 12:50:03 04/07/2006	BY: PG.OHHO
FILE: \PGA\00007\806		TG: TS35TSN-2.MCS.V1.EGOV.0.5.MH.06CHGR.ELECTRICAL_DRAWING
MTL: --		

BALDOR ELECTRIC Co.

10.84035-G1-ELE

Figure A-15 TS60 Connection Diagram

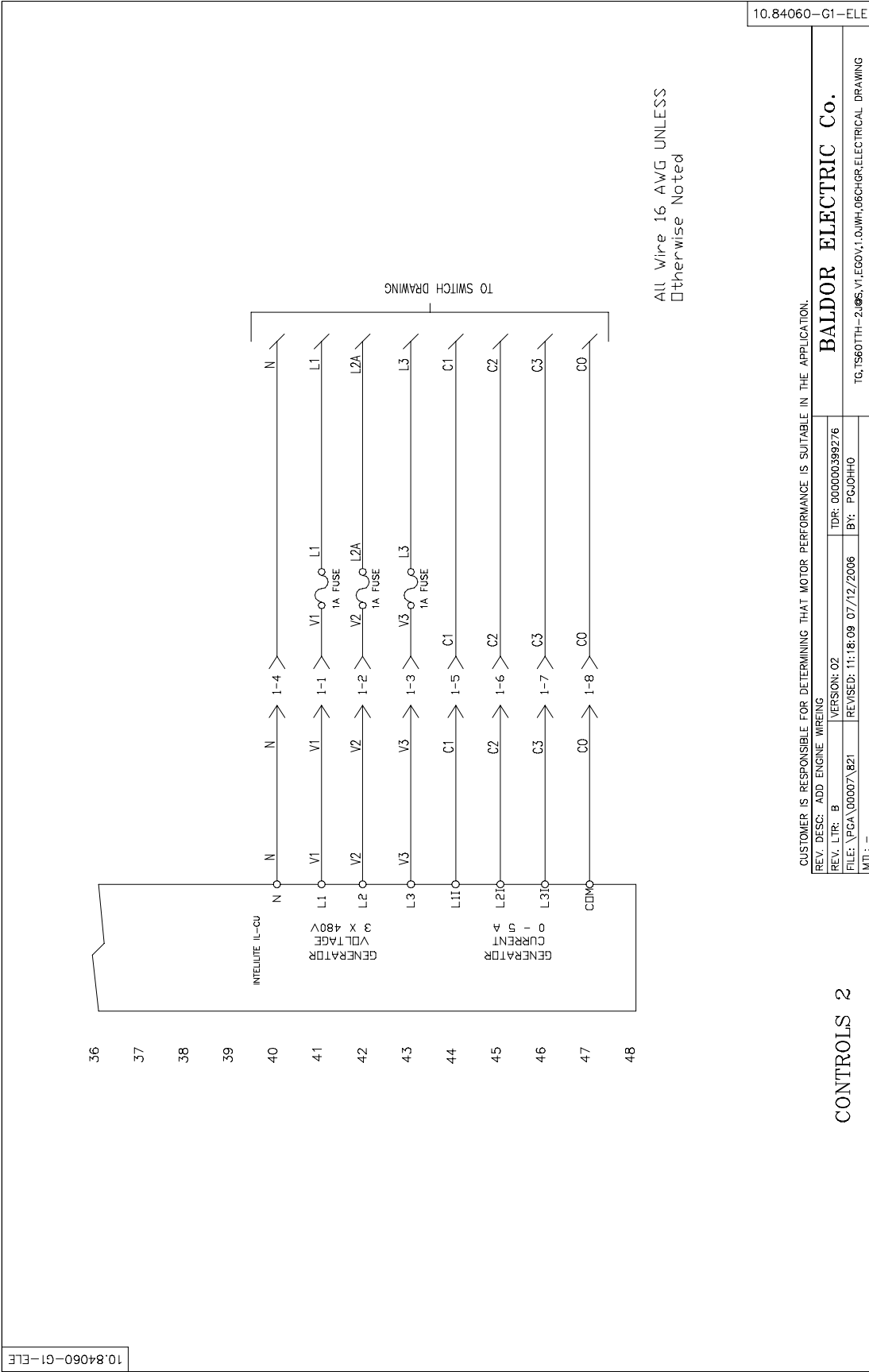

10.84060-G1-ELE

CUSTOMER IS RESPONSIBLE FOR DETERMINING THAT MOTOR PERFORMANCE IS SUITABLE IN THE APPLICATION.

REV. DESC: ADD ENGINE WIRING	VERSION: 02	TDR: 000000399276
REV. LTR: B	REVISED: 11:18:09 07/12/2006	BY: PGJOHHO
FILE: \PGA\00007\B21		TG:TS60TTH-2.065.V1.EG0V.1.0UWH.06CHGR.ELECTRICAL DRAWING
MFL: --		

BALDOR ELECTRIC Co.

CONTROLS 2

10.84060-G1-ELE

Figure A-16 TS60 Connection Diagram

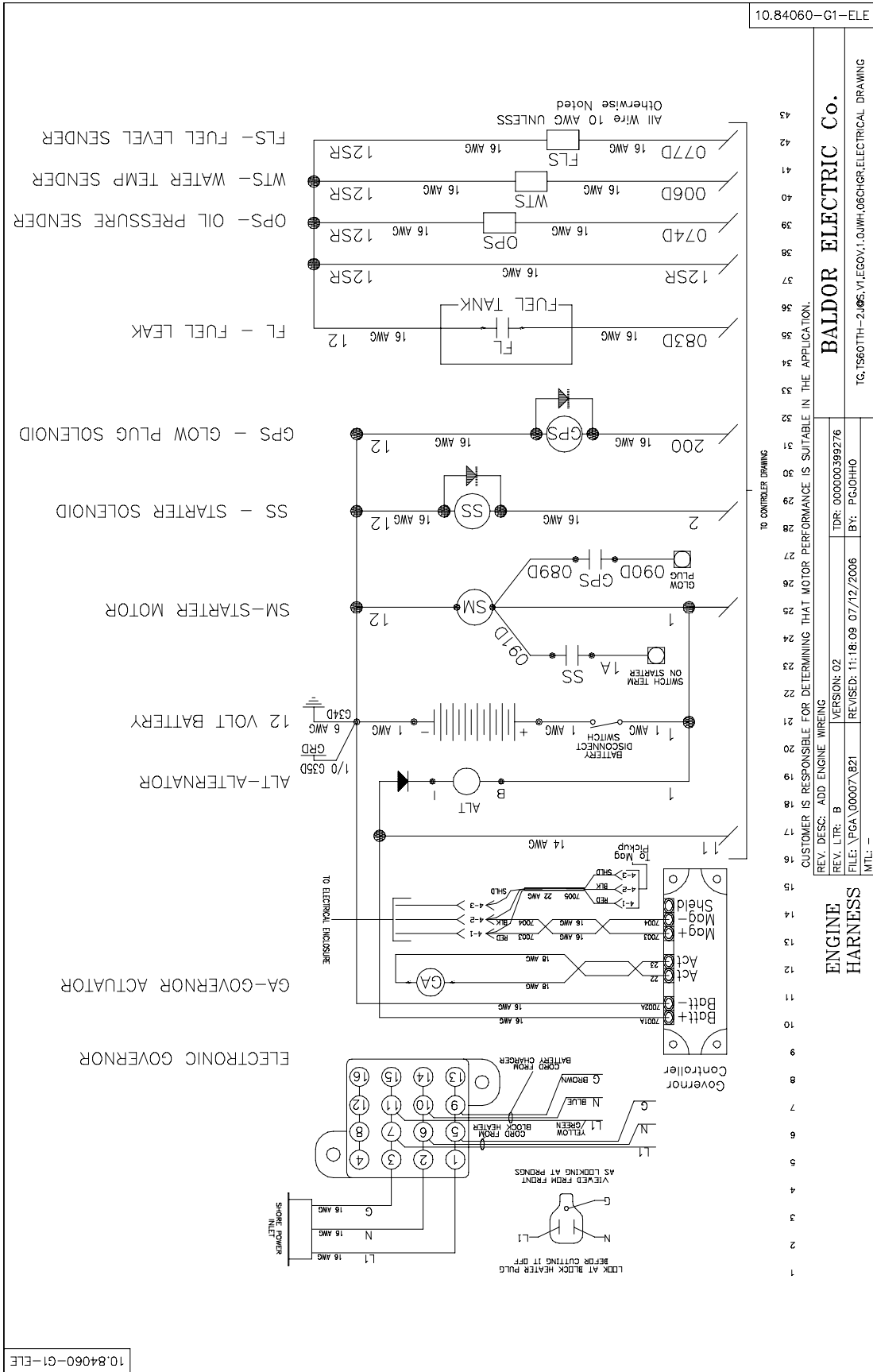

10.84060-G1-ELE

TO CONTROLLER DRAWING

1 2 3 4 5 6 7 8 9 10 11 12 13 14 15 16 17 18 19 20 21 22 23 24 25 26 27 28 29 30 31 32 33 34 35 36 37 38 39 40 41 42 43

Customer is responsible for determining that motor performance is suitable in the application.

BALDOR ELECTRIC Co.

TG, TS60TTH--2,065, V1, EGOV, 1, 0, WH, 06CHGR, ELECTRICAL, DRAWING

REV. LTR: B
REV. DESC: ADD ENGINE WIRING
FILE: \PGA\00007\821
MFL: -

VERSION: 02
TDR: 000000399276
BY: PG:JHHO

REVISED: 11:18:09 07/12/2006

10.84060-G1-ELE

Figure A-17 TS60 Connection Diagram

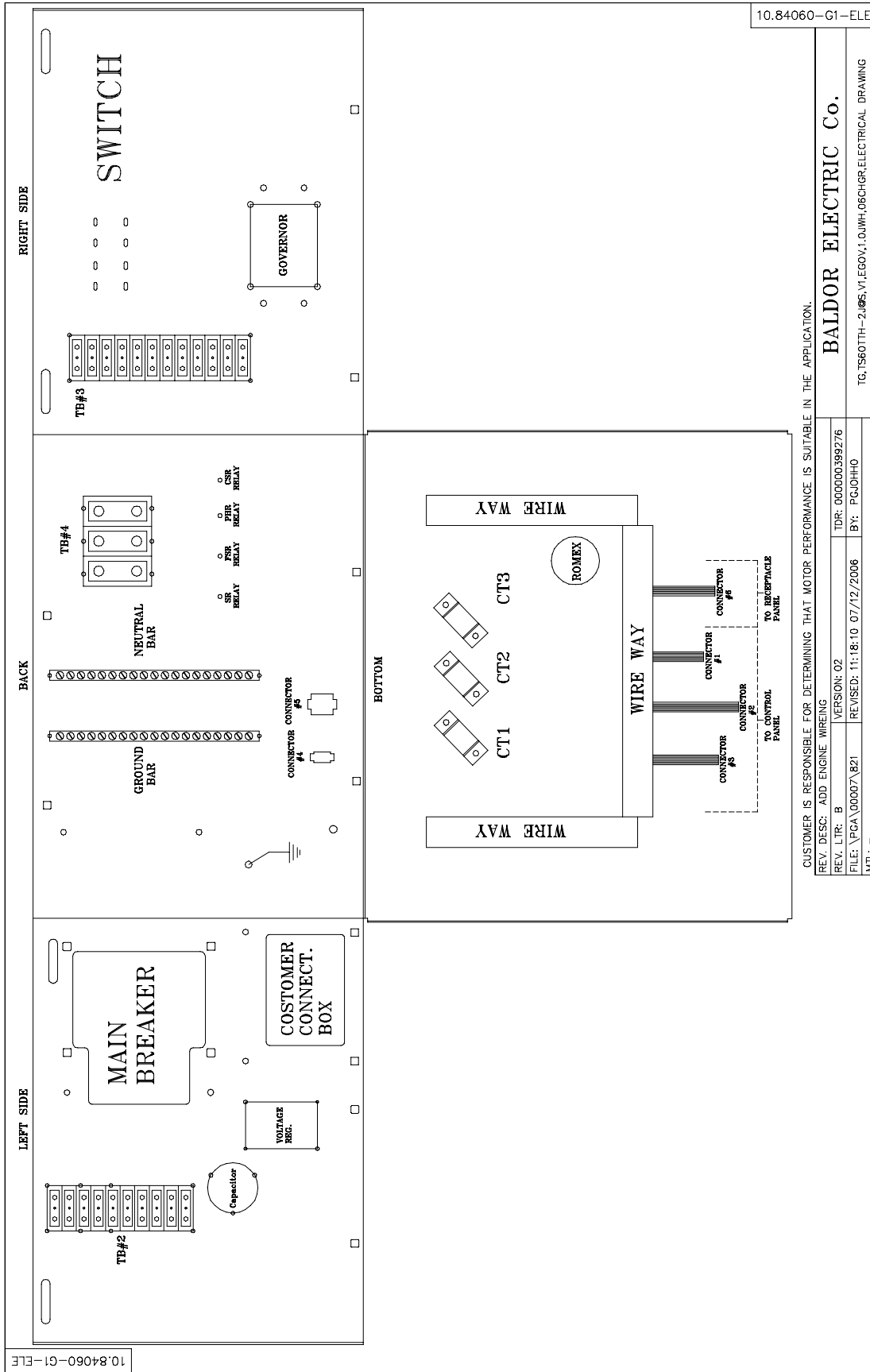

10.84060-G1-ELE

10.84060-G1-ELE

CUSTOMER IS RESPONSIBLE FOR DETERMINING THAT MOTOR PERFORMANCE IS SUITABLE IN THE APPLICATION.

REV. DESC: ADD ENGINE WIRING	VERSION: 02	TDR: 000000399276
REV. LTR: B	REVISION: 11:18:10 07/12/2006	BY: PGJOHHO
FILE: \PGA\00007\B21		TG:TS60TTH-2.06S.V1.EGOV.1.0UWH.06CHGR.ELECTRICAL DRAWING
MFL: --		

BALDOR ELECTRIC Co.

Figure A-18 TS60 Connection Diagram

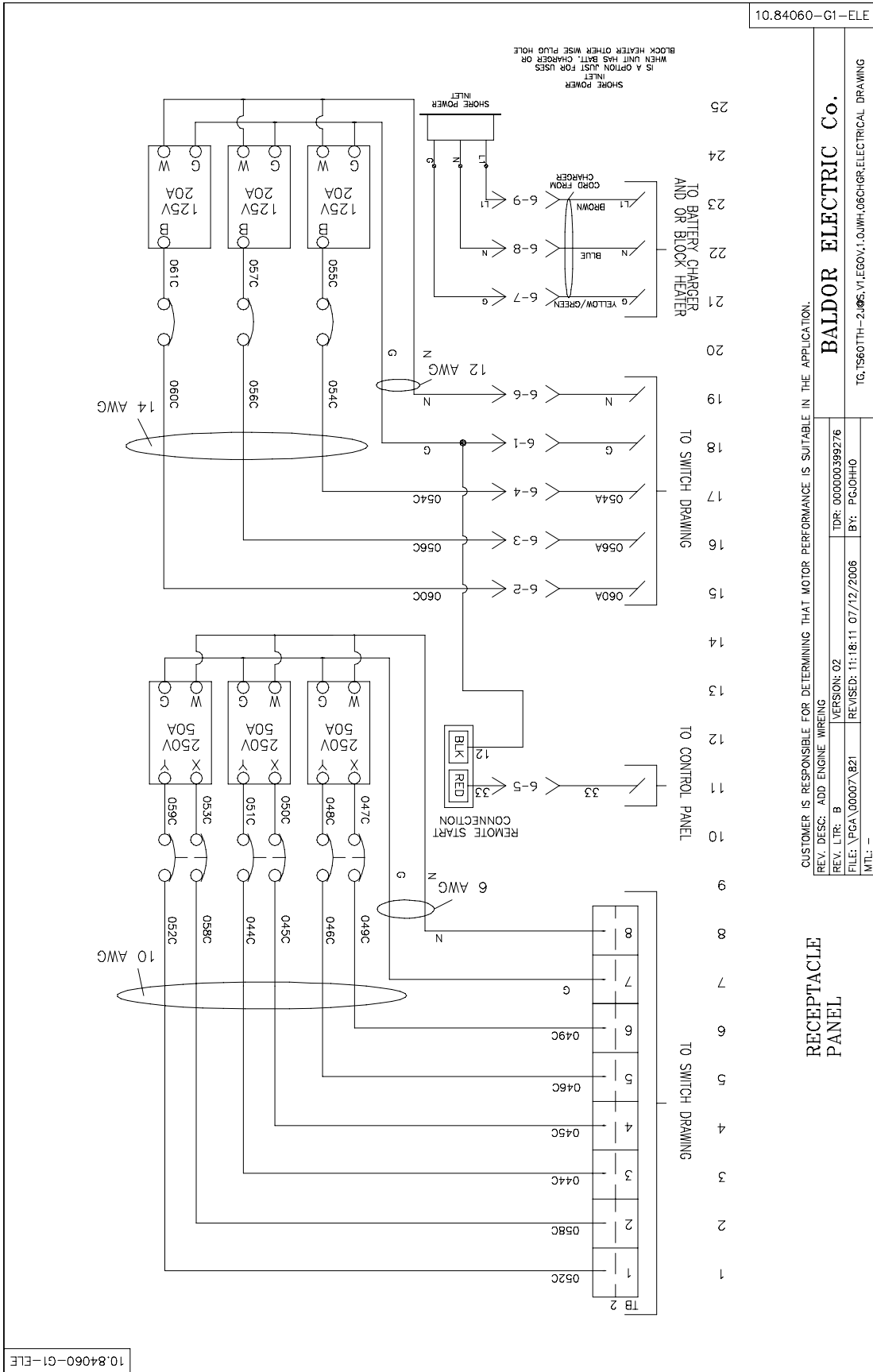

10.84060-G1-ELE

CUSTOMER IS RESPONSIBLE FOR DETERMINING THAT MOTOR PERFORMANCE IS SUITABLE IN THE APPLICATION.

REV. DESC: ADD ENGINE WIRING

REV. LTR: B

FILE: \PCA\00007\821

VERSION: 02

REVISED: 11:18:11 07/12/2006

TDR: 000000398276

BY: PG:JHHO

BALDOR ELECTRIC Co.

TG,TS60TTH-2,06,VI,EGOV,1,0,WH,06CHGR,ELECTRICAL DRAWING

MTL: -

Figure A-19 TS60 Connection Diagram

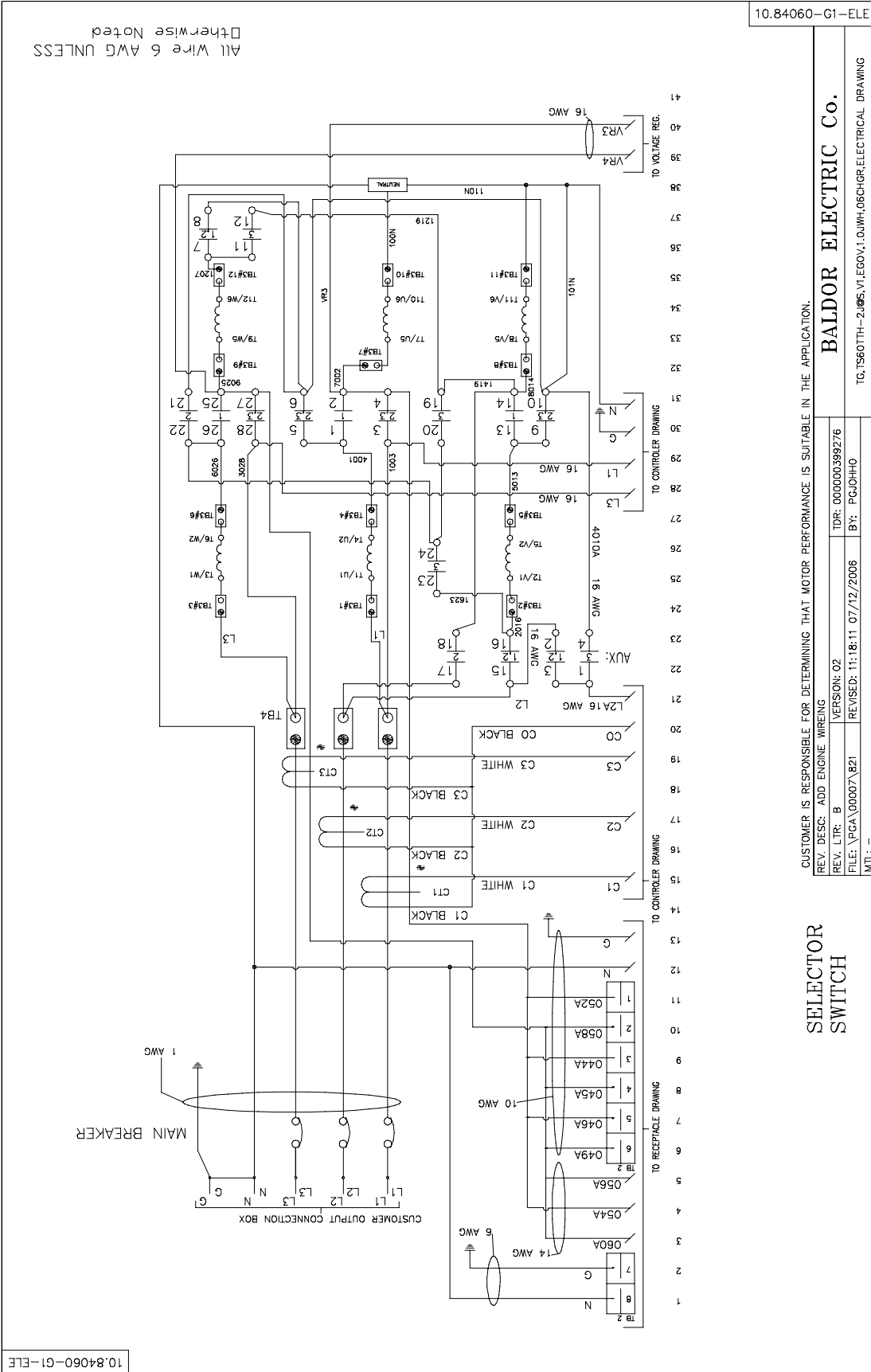

Figure A-20 TS60 Connection Diagram

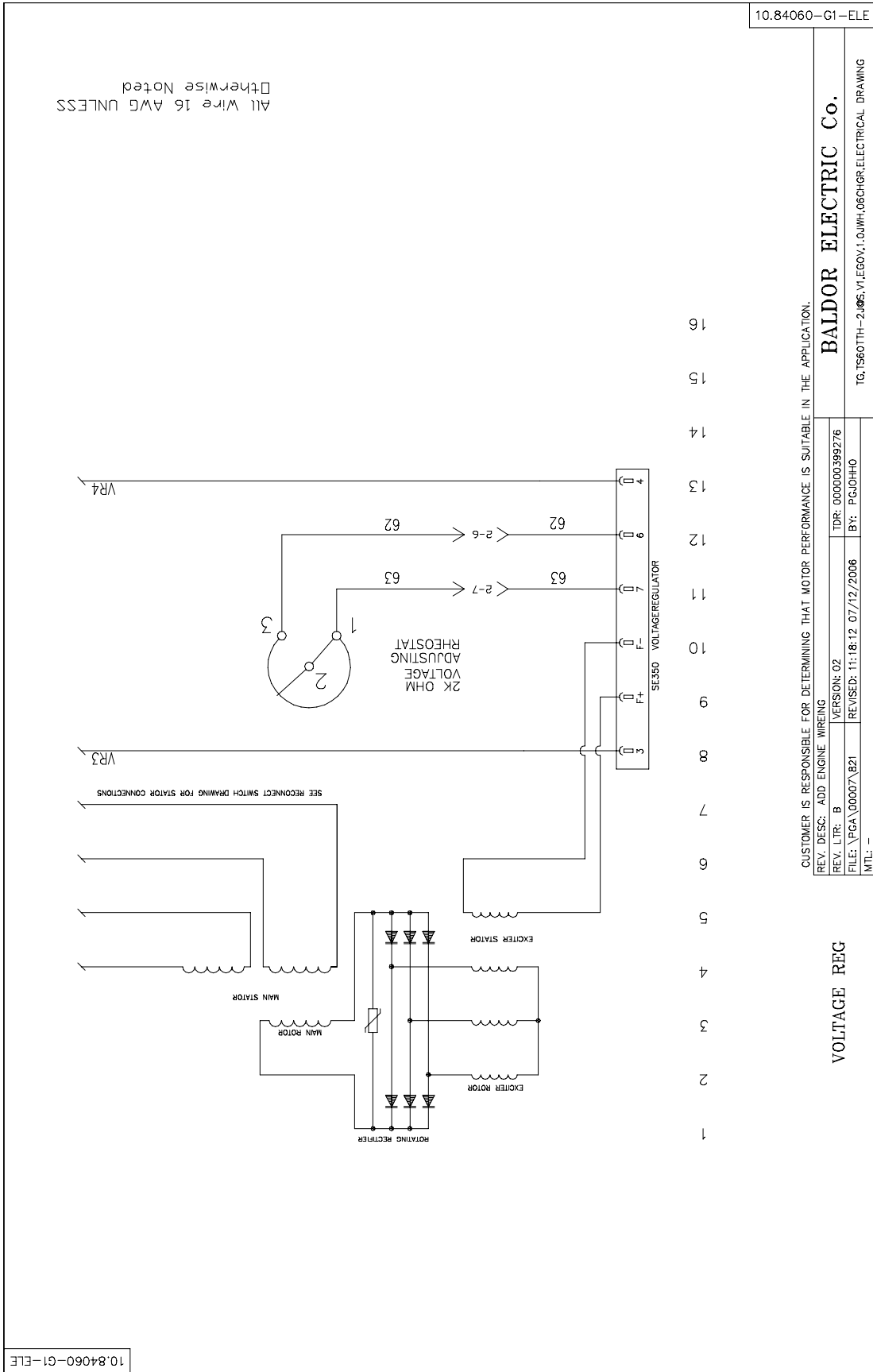

Figure A-21 TS80 Connection Diagram

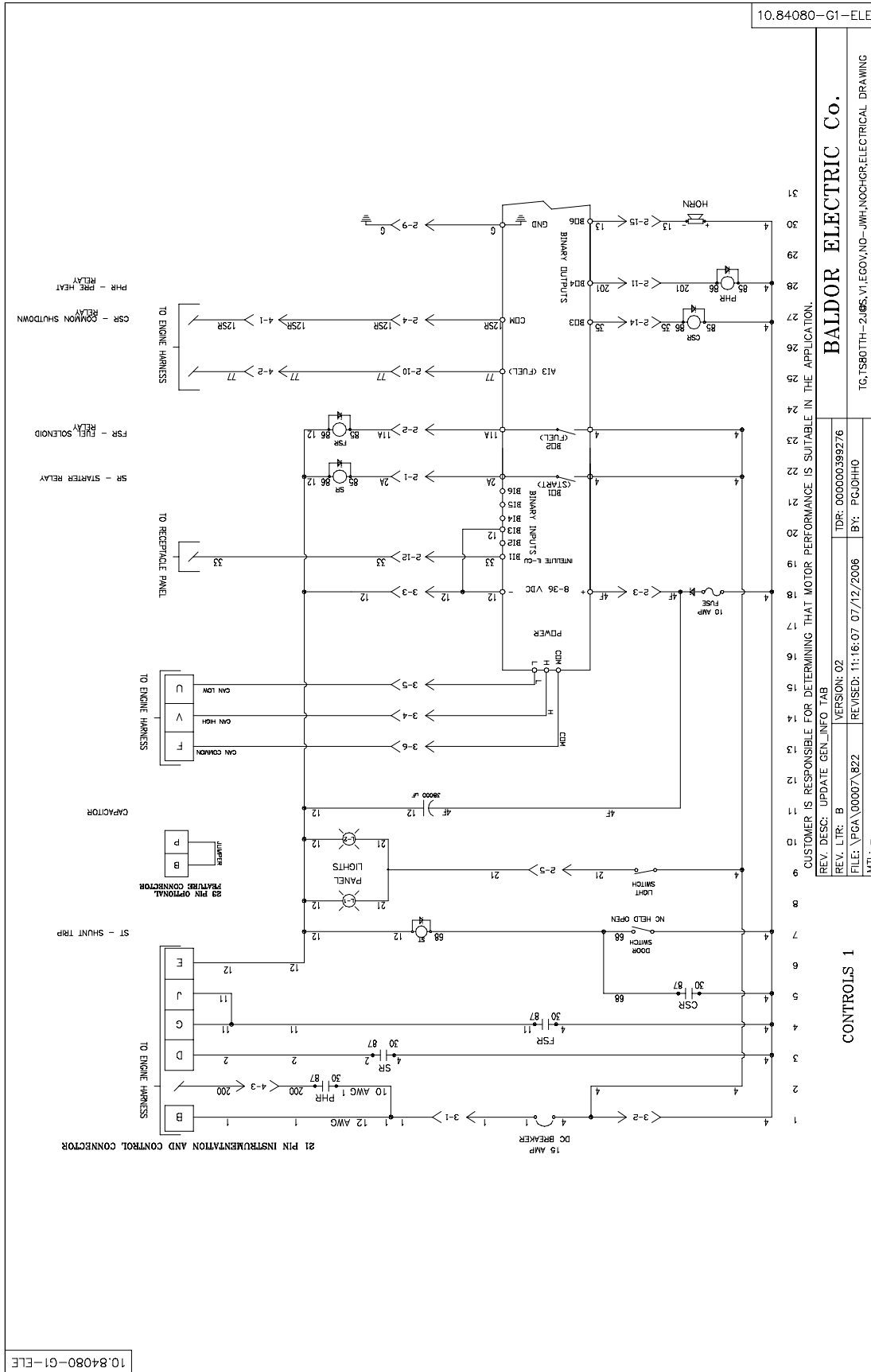
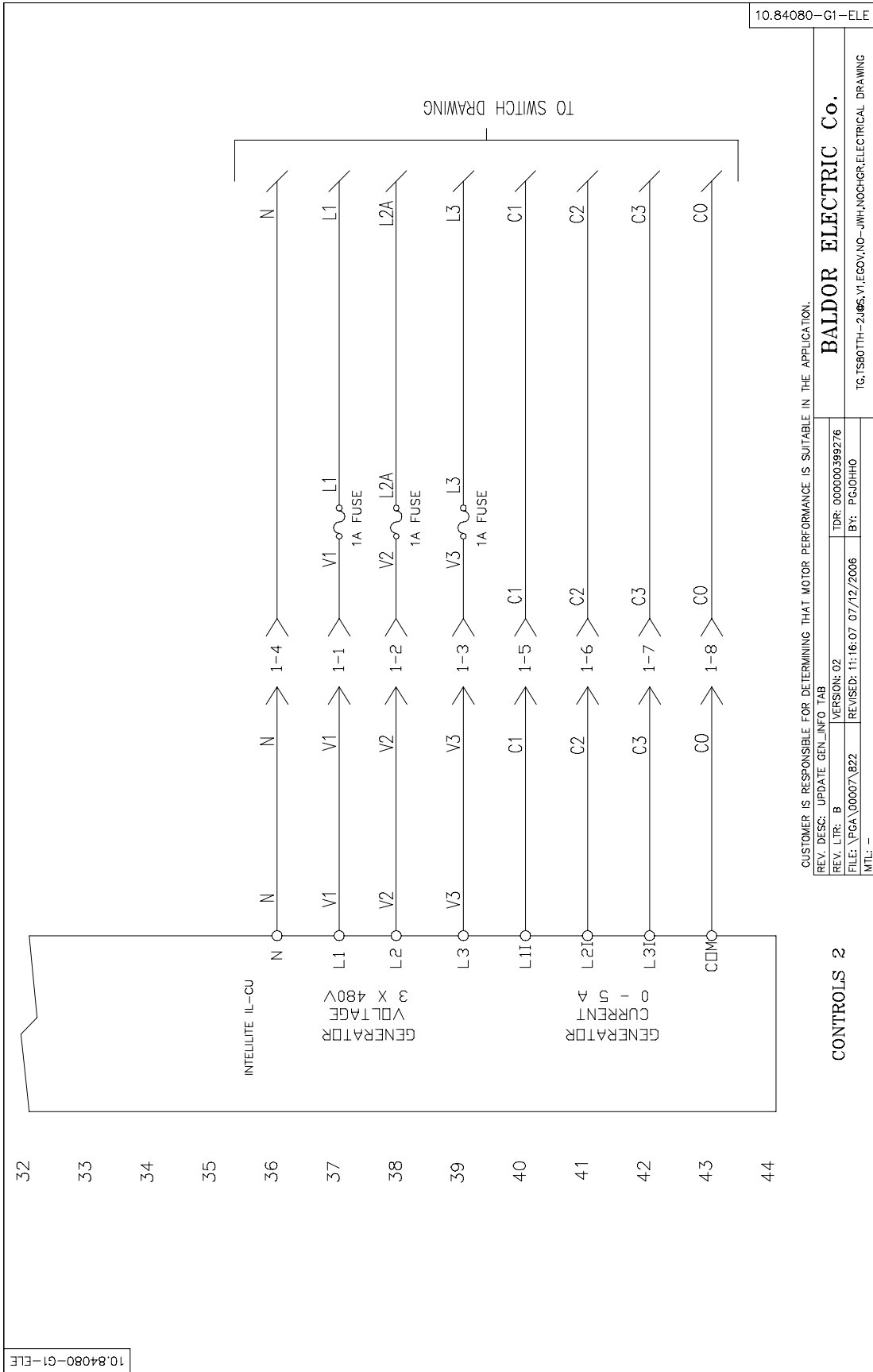

Figure A-22 TS80 Connection Diagram



10.84080-G1-ELE

CUSTOMER IS RESPONSIBLE FOR DETERMINING THAT MOTOR PERFORMANCE IS SUITABLE IN THE APPLICATION.

CONTROLS 2

BALDOR ELECTRIC Co.
TG:TS80TTH-2486; V1, EGO, NO-JWH, NOCHGR, ELECTRICAL DRAWING

Figure A-23 TS80 Connection Diagram

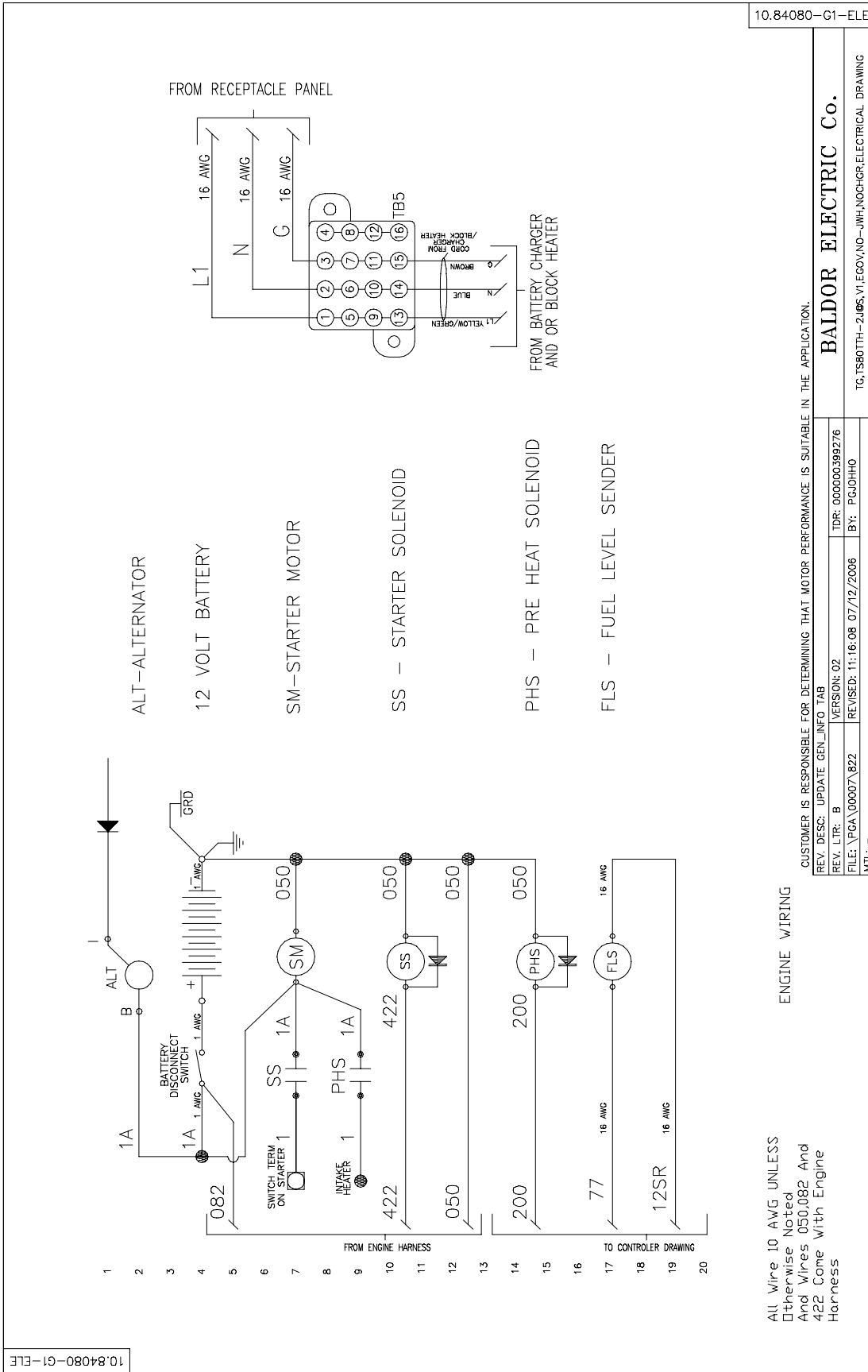

Figure A-24 TS80 Connection Diagram

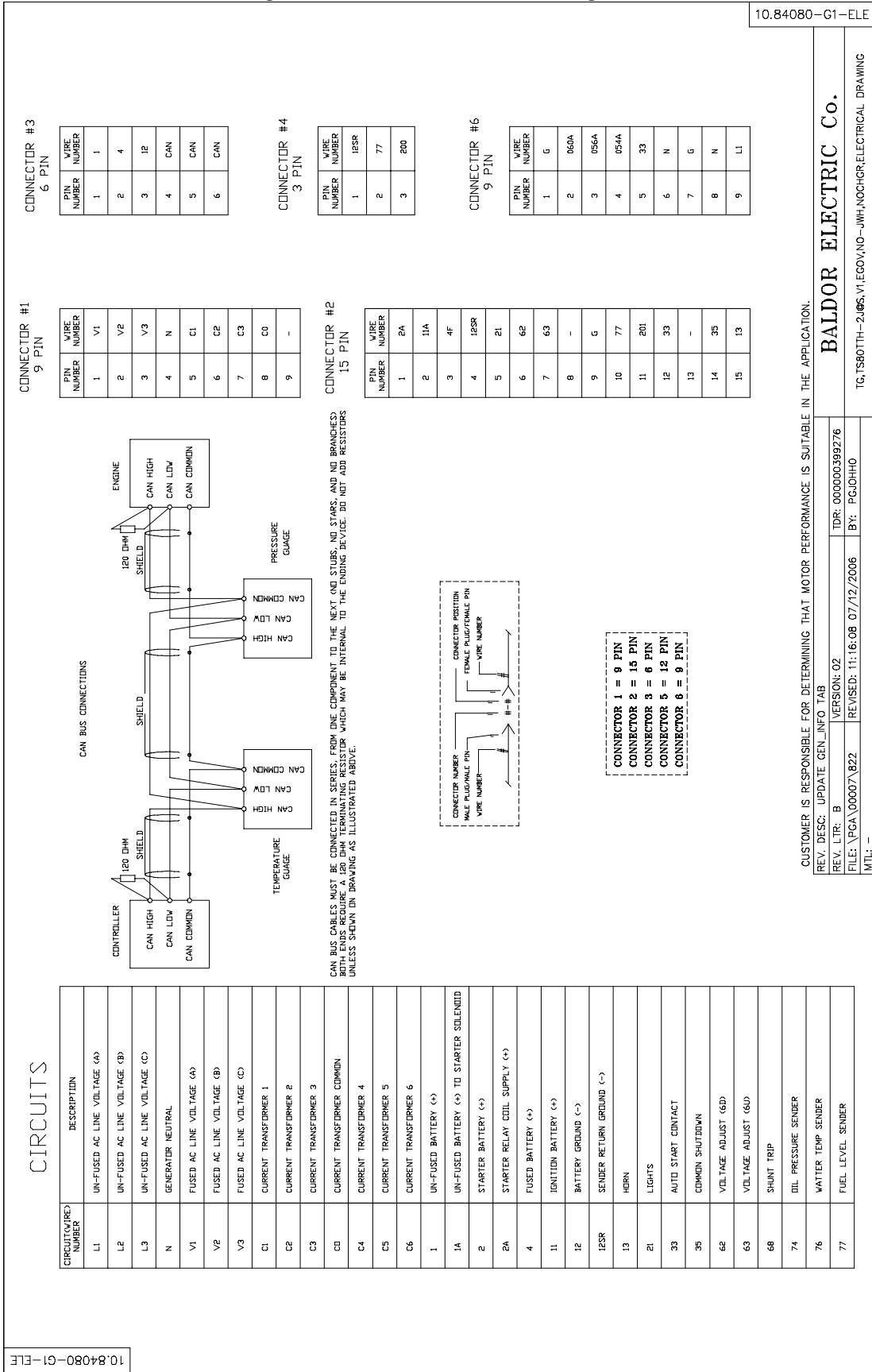
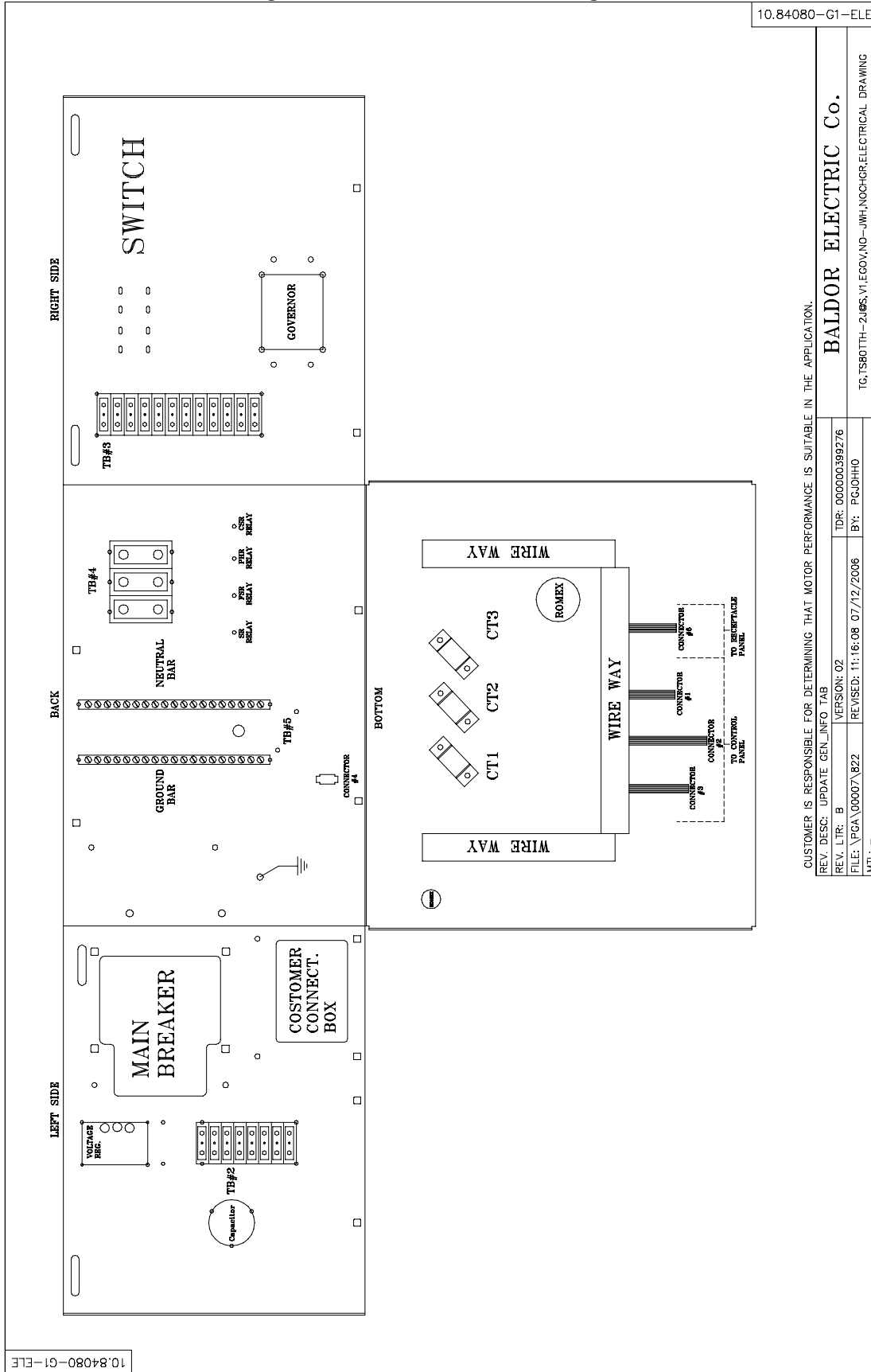

Figure A-25 TS80 Connection Diagram



10.84080-G1-ELE

CUSTOMER IS RESPONSIBLE FOR DETERMINING THAT MOTOR PERFORMANCE IS SUITABLE IN THE APPLICATION.

REV. DESC: UPDATE GEN_INFO TAB	TDR: 000000399276
REV. LTR: B	VERSION: 02
FILE: \PGA\00007\822	REVISED: 11:16:08 07/12/2006
BY: PGJOHHO	BY: PGJOHHO
MTL: --	

BALDOR ELECTRIC Co.

TG,TS80TTH-2,195,VI,EGOV,NO-JWH,NOCHGR,ELECTICAL DRAWING

Figure A-26 TS80 Connection Diagram

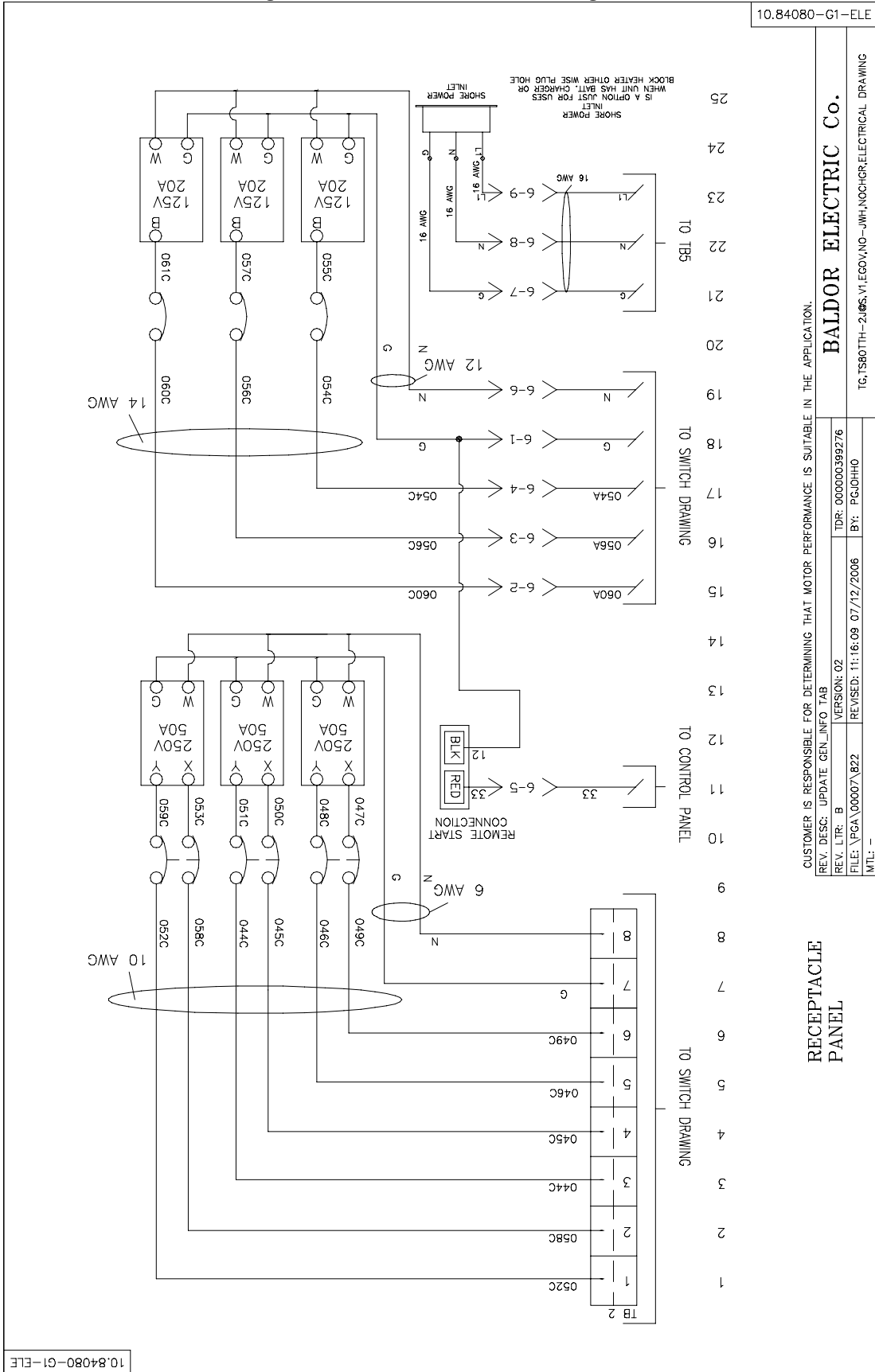

Figure A-27 TS80 Connection Diagram

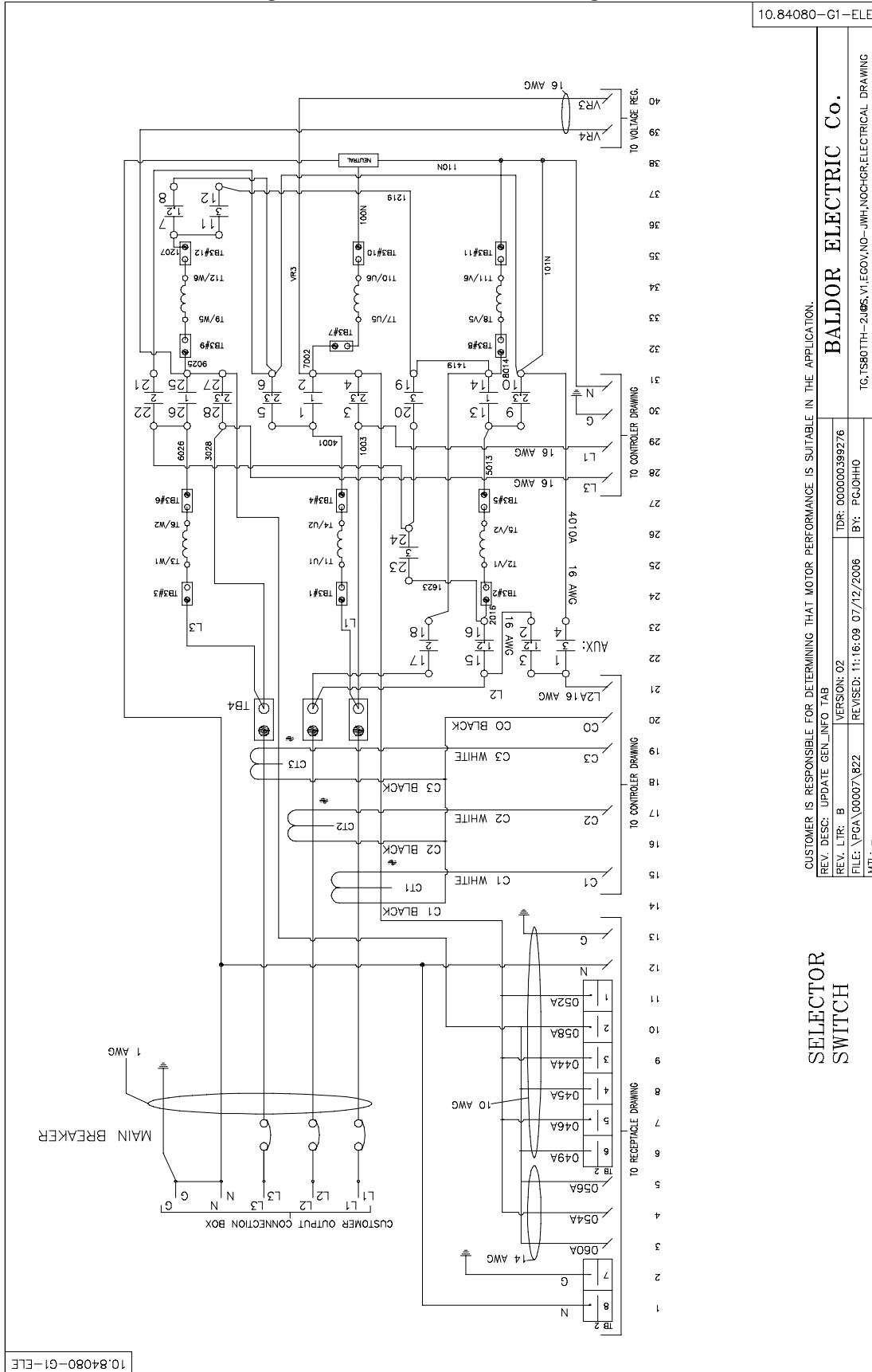
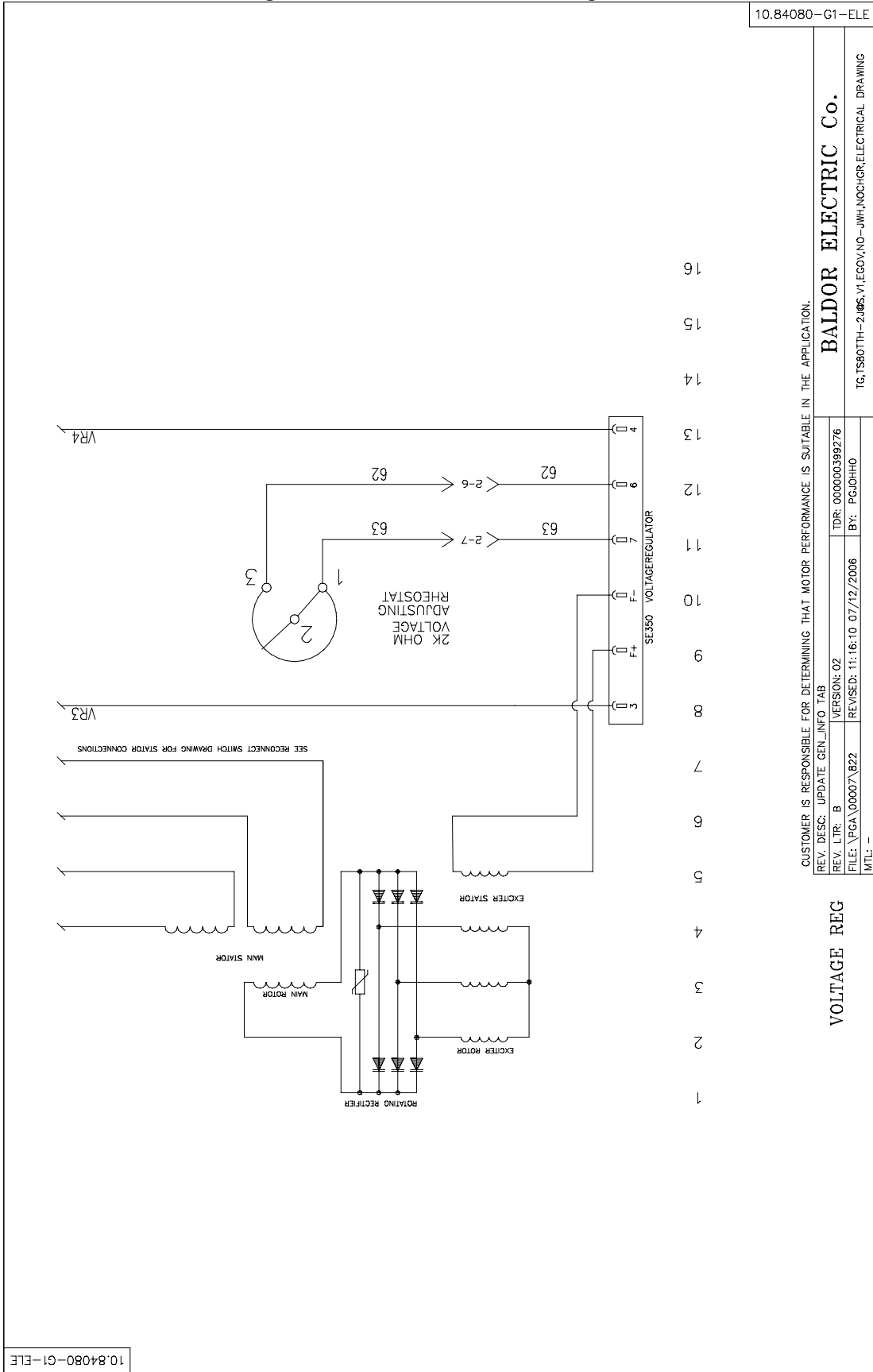

Figure A-28 TS80 Connection Diagram



10.84080-G1-ELE

CUSTOMER IS RESPONSIBLE FOR DETERMINING THAT MOTOR PERFORMANCE IS SUITABLE IN THE APPLICATION.

REV. DESC: UPDATE GEN_INFO TAB

REV. LTR: B

FILE: \PCA\00007\822

MTL: -

VERSION: 02

REVISION: 11:16:10 07/12/2006

TDR: 000000398276

BY: PGJHHO

BALDOR ELECTRIC Co.

TG,TS80THH-2,065.V1,EGOV,NO-JWH,NOCHGR,ELECTRICAL DRAWING

VOLTAGE REG

Figure A-29 TS80 Connection Diagram

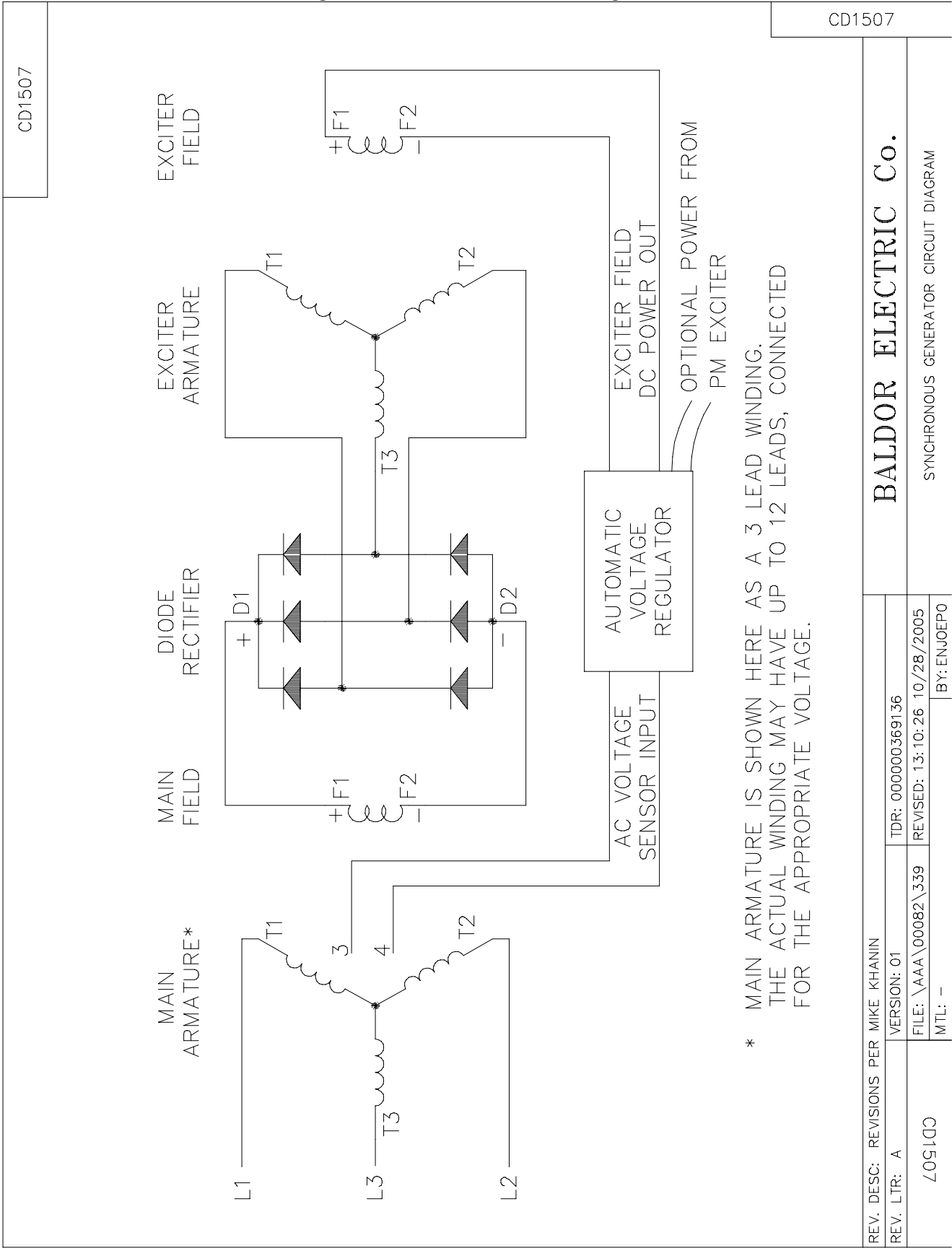

* MAIN ARMATURE IS SHOWN HERE AS A 3 LEAD WINDING. THE ACTUAL WINDING MAY HAVE UP TO 12 LEADS, CONNECTED FOR THE APPROPRIATE VOLTAGE.

REV. DESC: REVISIONS PER MIKE KHANIN	TDR: 000000369136
REV. LTR: A	VERSION: 01
CD1507	FILE: \AAA\00082\339
MTL: -	REvised: 13: 10: 26 10/28/2005
	BY: ENJOEPO

BALDOR ELECTRIC Co.

SYNCHRONOUS GENERATOR CIRCUIT DIAGRAM

CD1507

Figure A-30 TS80 Connection Diagram

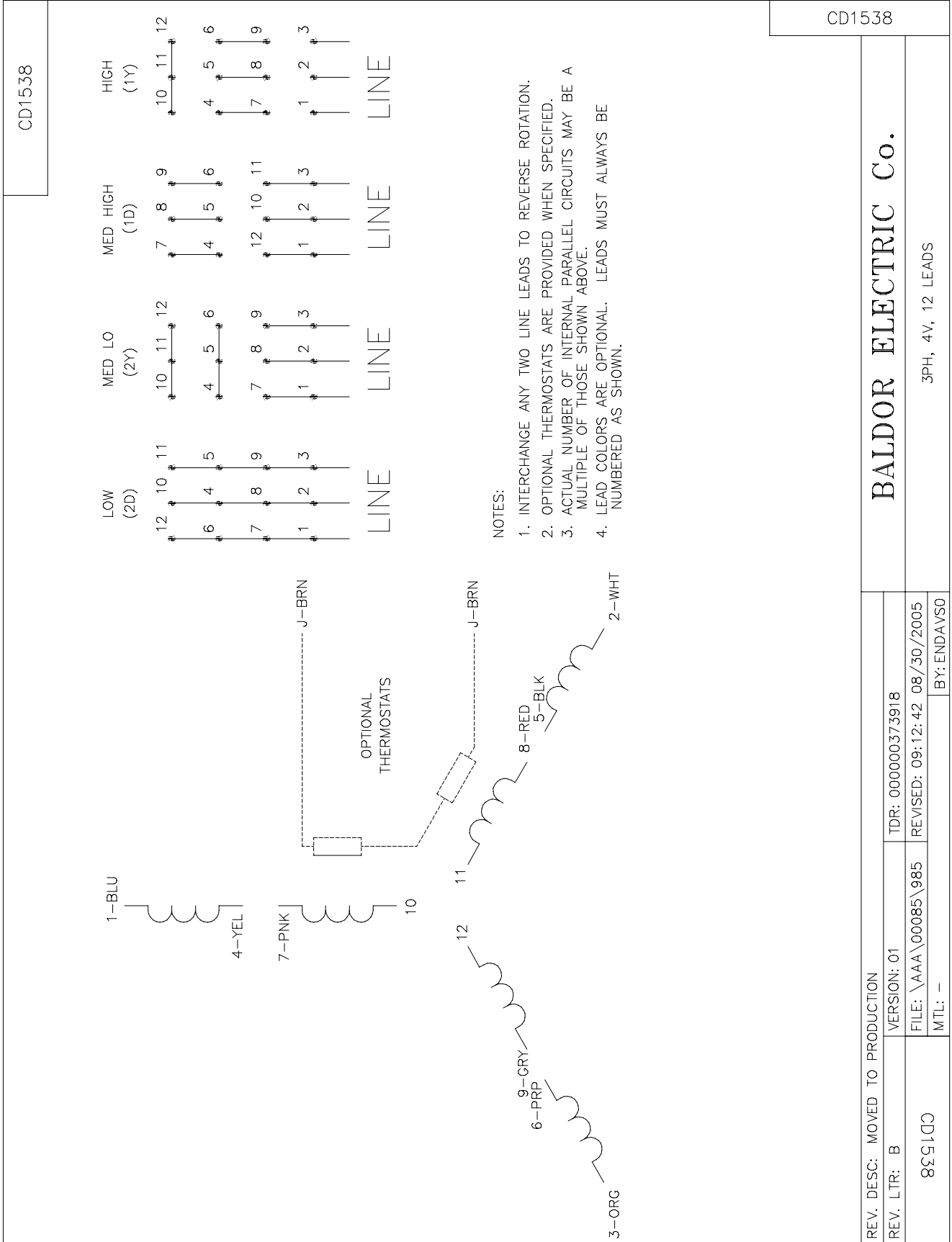

Figure A-31 TS400 Connection Diagram

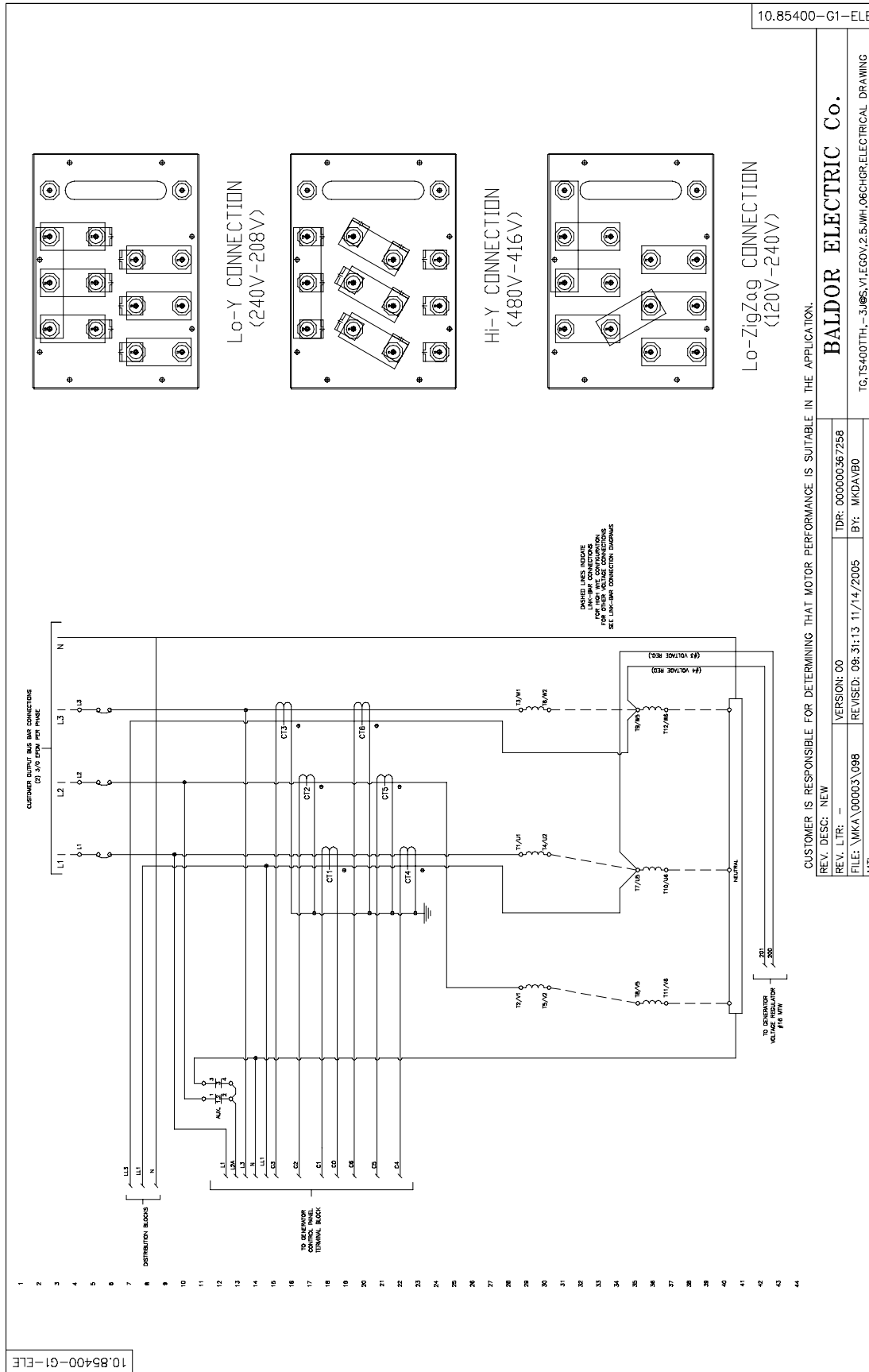

Figure A-32 TS400 Connection Diagram

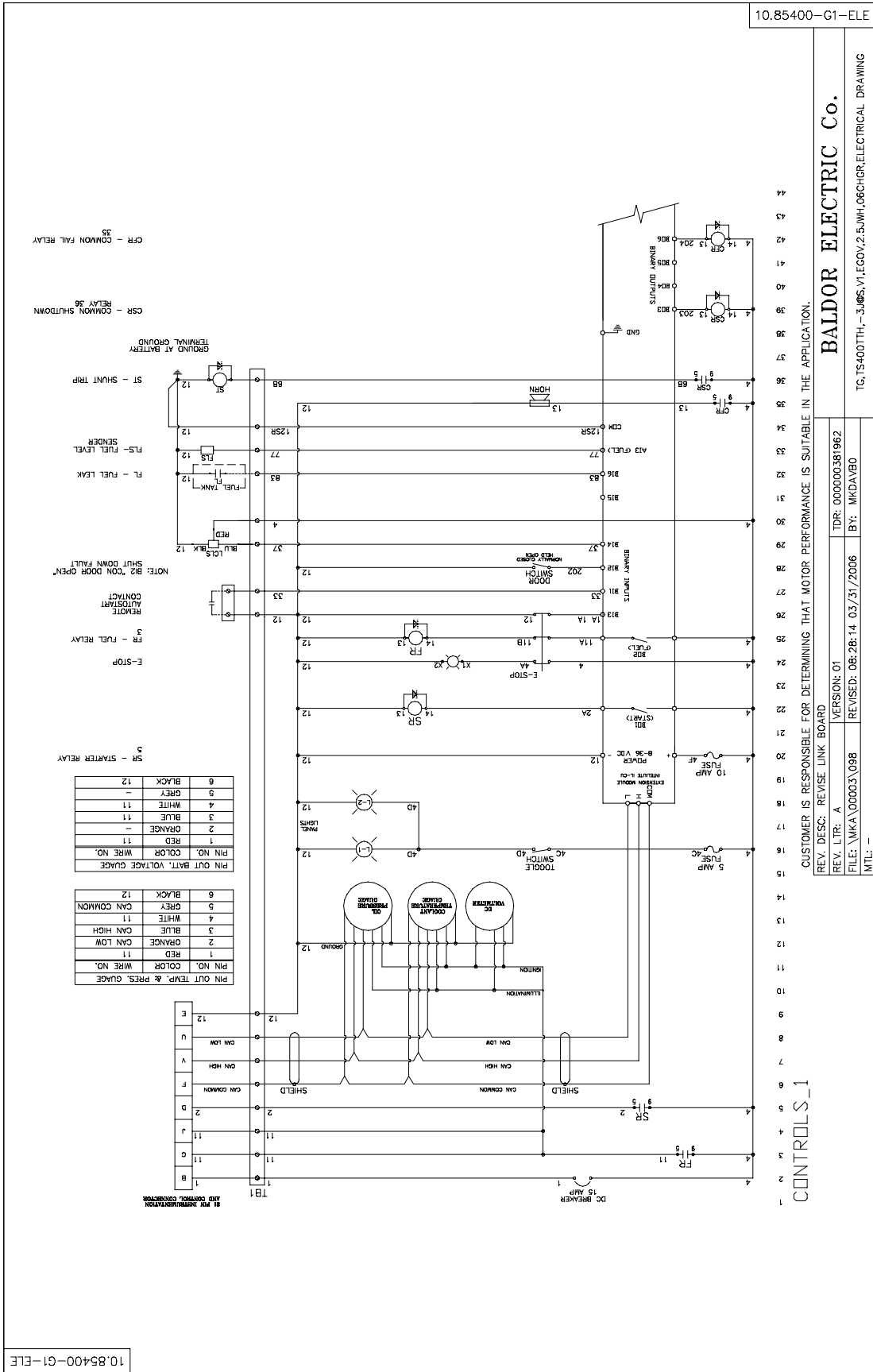
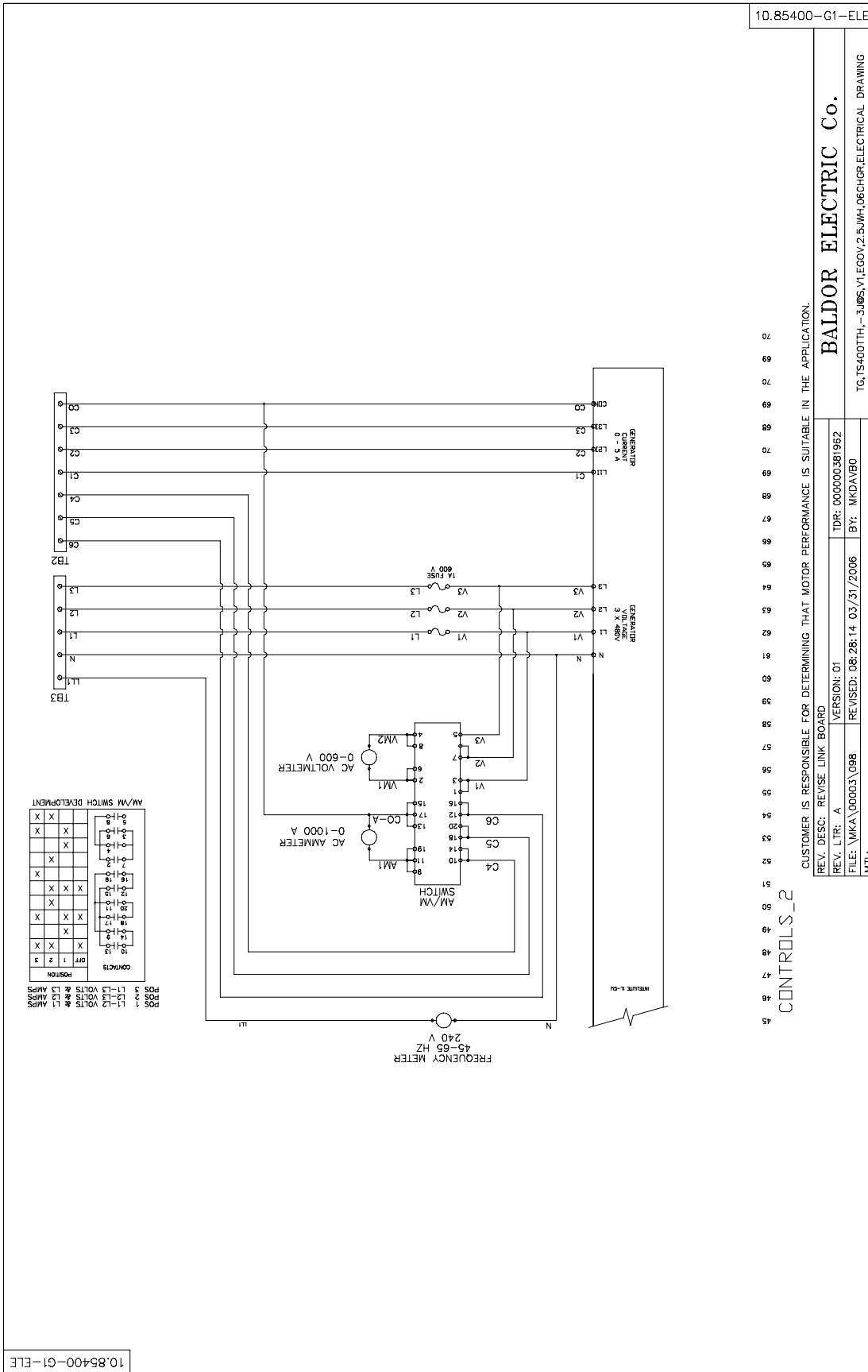

Figure A-33 TS400 Connection Diagram



10.85400-G1-ELE

CUSTOMER IS RESPONSIBLE FOR DETERMINING THAT MOTOR PERFORMANCE IS SUITABLE IN THE APPLICATION.

BALDOR ELECTRIC Co.	
TDR: 000000381962	BY: MKDAVB0
REV. LTR: A	VERSION: 01
REVISED: 08/28/14 03/31/2006	FILE: \MKA\00003\098
T6, T5 400TTH, -3.00S, V1.EGOV, 2.5JWH, 06CHGR, ELECTRICAL DRAWING	
MFL: -	

Figure A-34 TS400 Connection Diagram

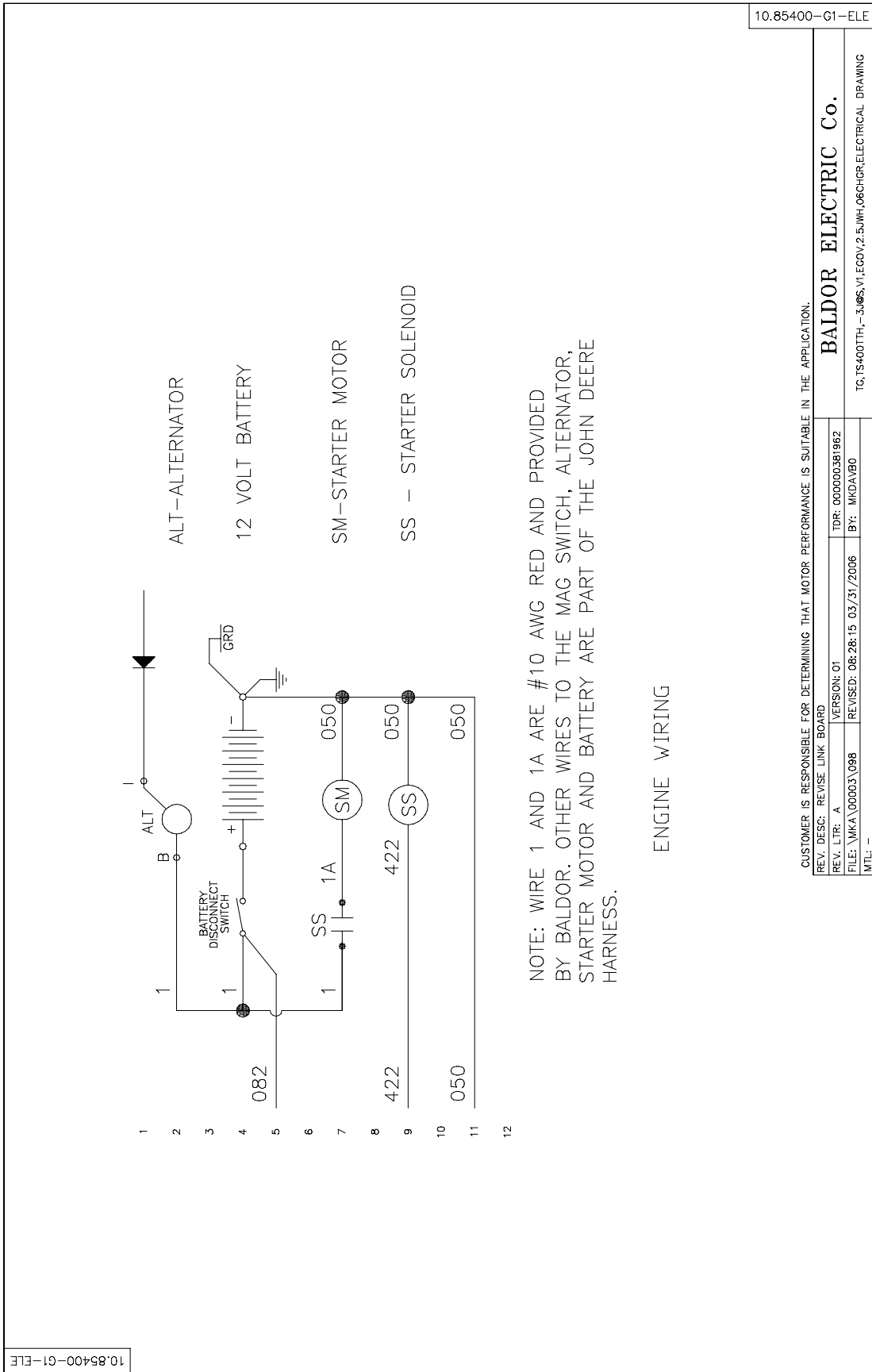

NOTE: WIRE 1 AND 1A ARE #10 AWG RED AND PROVIDED BY BALDOR. OTHER WIRES TO THE MAG SWITCH, ALTERNATOR, STARTER MOTOR AND BATTERY ARE PART OF THE JOHN DEERE HARNESS.

ENGINE WIRING

10.85400-G1-ELE

10.85400-G1-ELE

CUSTOMER IS RESPONSIBLE FOR DETERMINING THAT MOTOR PERFORMANCE IS SUITABLE IN THE APPLICATION.

REV. DESC: REVISE LINK BOARD		TDR: 000000381962	
REV. LTR: A		VERSION: 01	
FILE: MKA\00003\098		REVISED: 08/28/15 03/31/2006	
MTL: -		BY: MKDAVB0	
		TG: TS400TTH--310S,V1.EGOV.2.5.WH.06CHGR.ELECTRICAL DRAWING	

BALDOR ELECTRIC Co.

Figure A-35 TS400 Connection Diagram

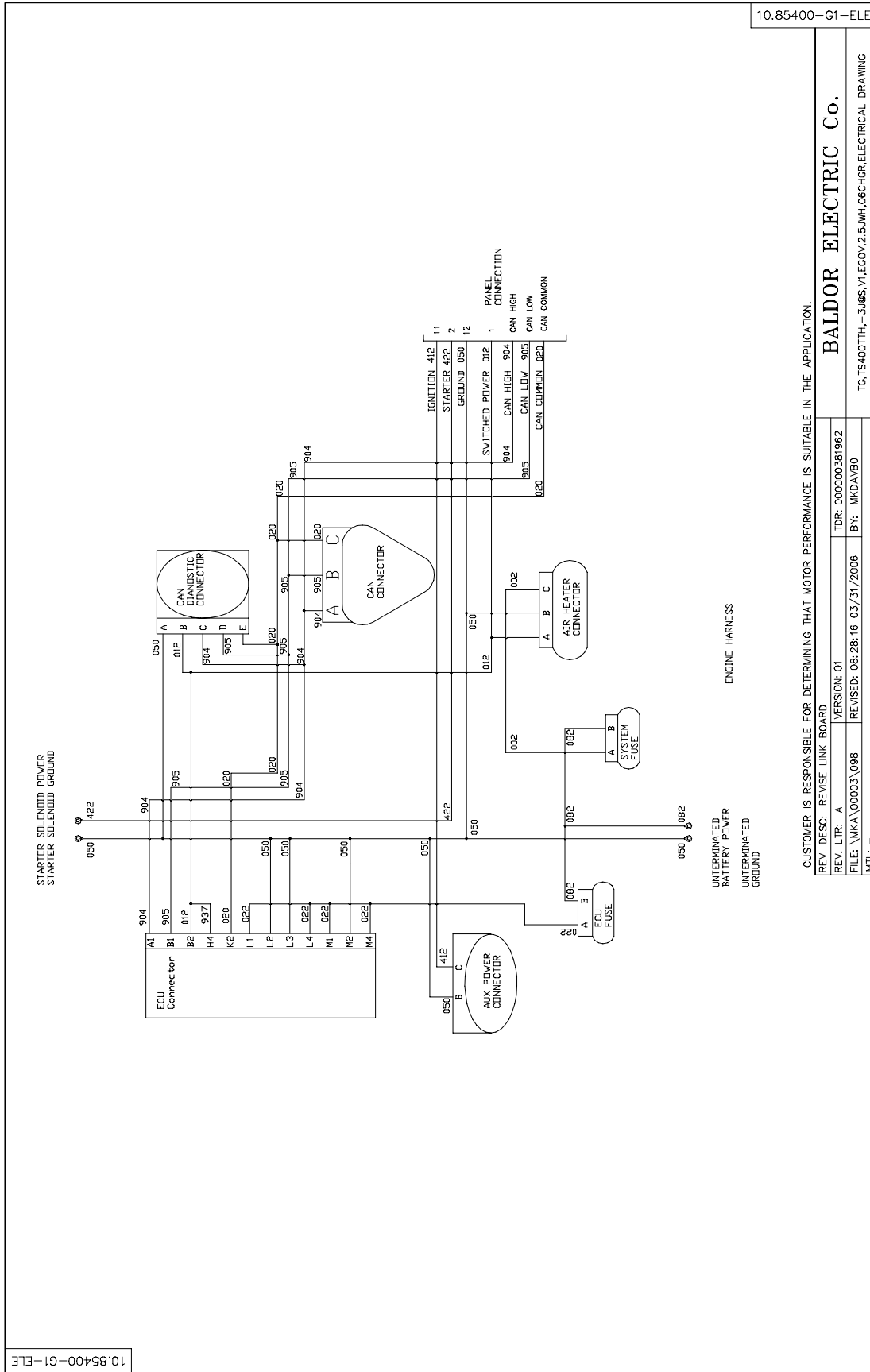
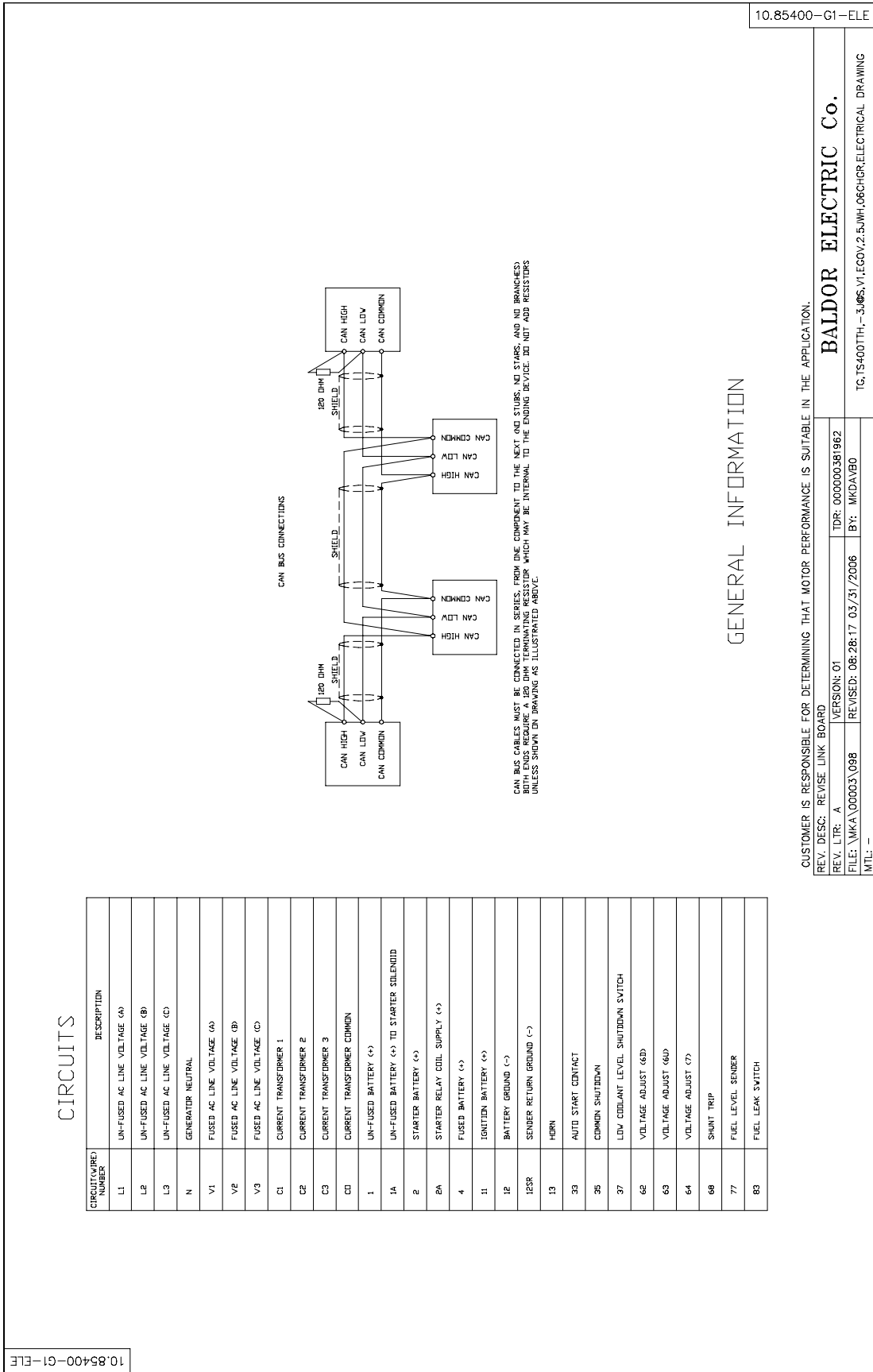

Figure A-36 TS400 Connection Diagram



GENERAL INFORMATION

10.85400-G1-ELE

CUSTOMER IS RESPONSIBLE FOR DETERMINING THAT MOTOR PERFORMANCE IS SUITABLE IN THE APPLICATION.

REV. DESC: REVISE LINK BOARD | TDR: 000000381962 | **BALDOR ELECTRIC Co.**

REV. LTR: A | VERSION: 01 | REVISOR: 08/28/17 03/31/2006 | BY: MKDAVB0

FILE: \\MKA\00003\098 | REVISED: 08/28/17 03/31/2006 | T6,TS400TH,-3,06S,V1,EGOV,2.5,MH,06CHGR,ELECTRICAL DRAWING

MTL: -

10.85400-G1-ELE

Figure A-37 TS400 Connection Diagram

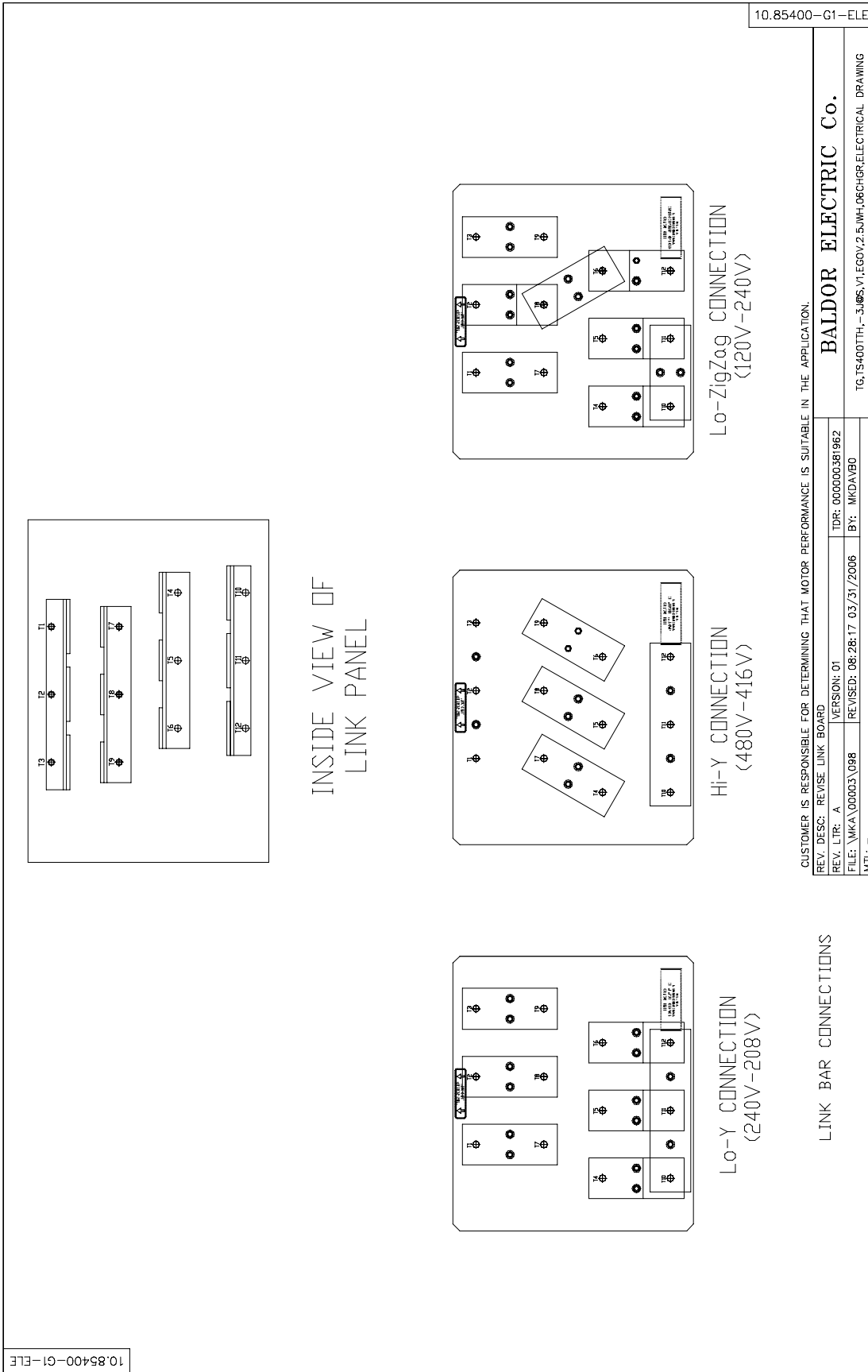

Figure A-38 TS400 Connection Diagram

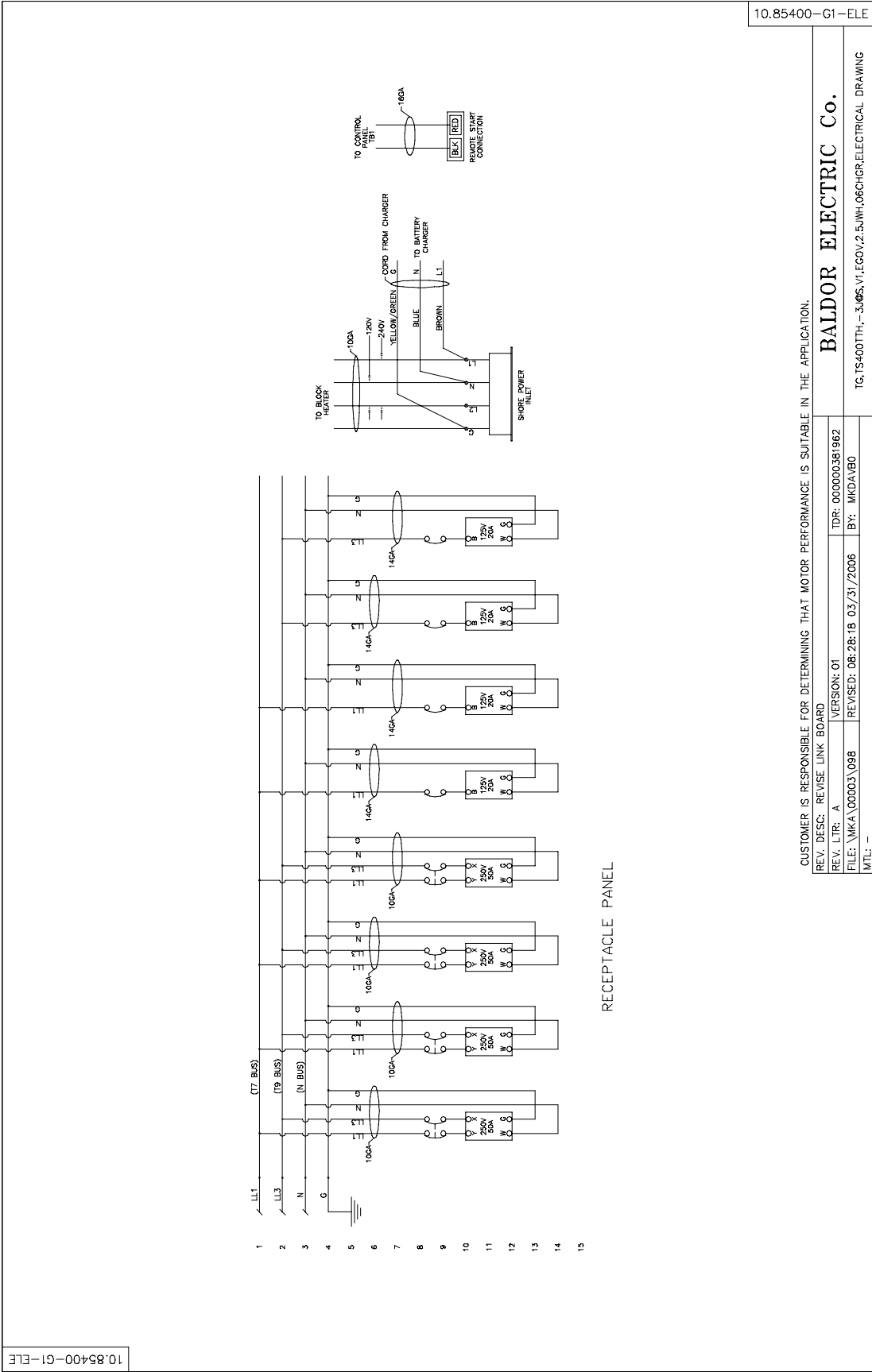
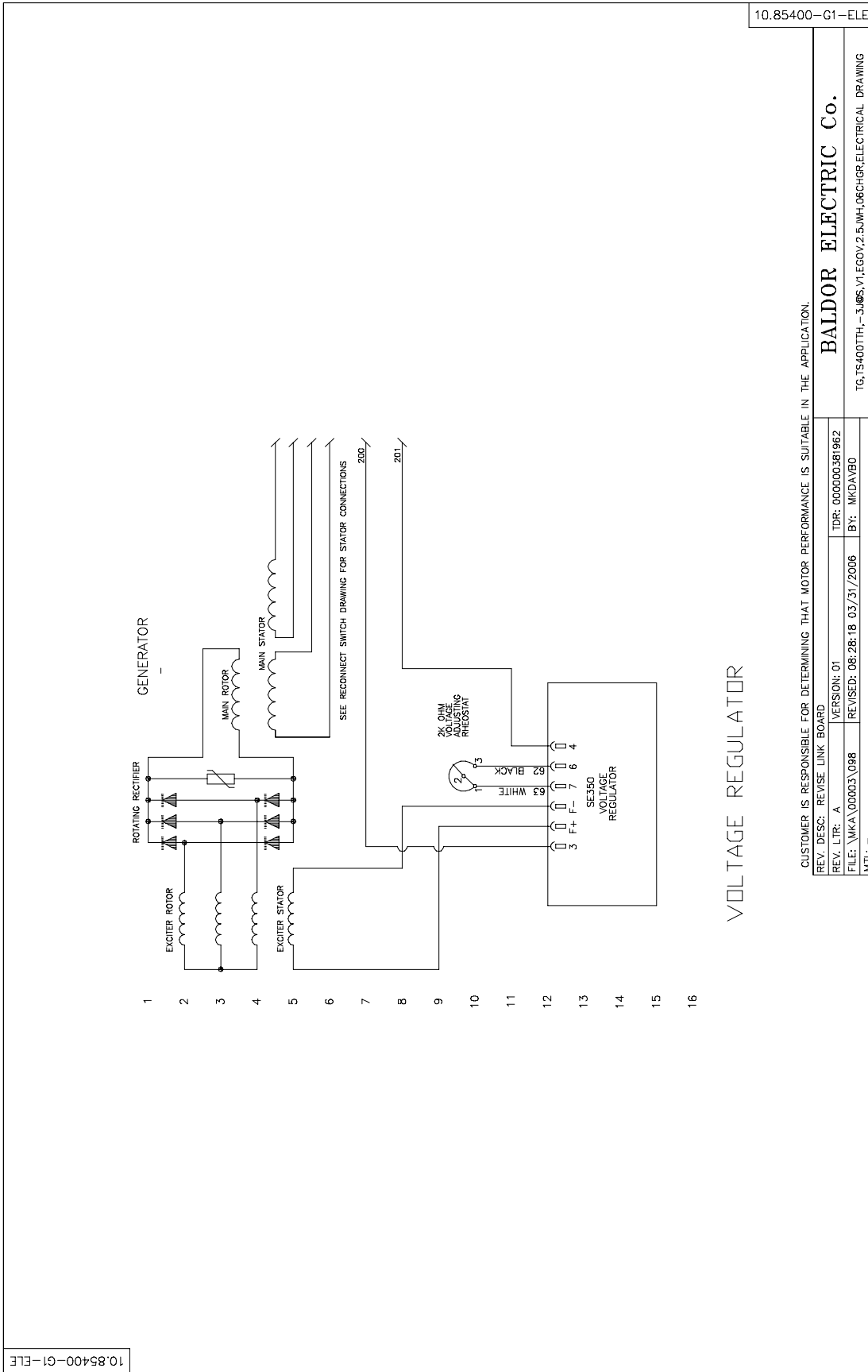

Figure A-39 TS400 Connection Diagram



Baldor District Offices

UNITED STATES

ARIZONA
PHOENIX
4211 S 43RD PLACE
PHOENIX, AZ 85040
PHONE: 602-470-0407
FAX: 602-470-0464

ARKANSAS
CLARKSVILLE
1001 COLLEGE AVE.
CLARKSVILLE, AR 72830
PHONE: 479-754-9108
FAX: 479-754-9205

CALIFORNIA
LOS ANGELES
6480 FLOTILLA
COMMERCE, CA 90040
PHONE: 323-724-6771
FAX: 323-721-5859

HAYWARD
21056 FORBES STREET
HAYWARD, CA 94545
PHONE: 510-785-9900
FAX: 510-785-9910

COLORADO
DENVER
2520 W BARBERRY PLACE
DENVER, CO 80204
PHONE: 303-623-0127
FAX: 303-595-3772

CONNECTICUT
WALLINGFORD
65 SOUTH TURNPIKE ROAD
WALLINGFORD, CT 06492
PHONE: 203-269-1354
FAX: 203-269-5485

FLORIDA
TAMPA/PUERTO RICO/
VIRGIN ISLANDS
3906 EAST 11TH AVENUE
TAMPA, FL 33605
PHONE: 813-248-5078
FAX: 813-247-2984

GEORGIA
ATLANTA
62 TECHNOLOGY DR.
ALPHARETTA, GA 30005
PHONE: 770-772-7000
FAX: 770-772-7200

ILLINOIS
CHICAGO
1601 FRONTENAC ROAD
NAPERVILLE, IL 60563
PHONE: 630-848-5100
FAX: 630-848-5110

INDIANA
INDIANAPOLIS
5525 W. MINNESOTA STREET
INDIANAPOLIS, IN 46241
PHONE: 317-246-5100
FAX: 317-246-5110

IOWA
DES MOINES
1800 DIXON STREET, SUITE C
DES MOINES, IA 50316
PHONE: 515-263-6929
FAX: 515-263-6515

MARYLAND
BALTIMORE
6660 SANTA BARBARA RD.
SUITE 22-24
ELKRIDGE, MD 21075
PHONE: 410-579-2135
FAX: 410-579-2677

MASSACHUSETTS
BOSTON
6 PULLMAN STREET
WORCESTER, MA 01606
PHONE: 508-854-0708
FAX: 508-854-0291

MICHIGAN
DETROIT
33782 STERLING PONDS BLVD.
STERLING HEIGHTS, MI 48312
PHONE: 586-978-9800
FAX: 586-978-9969

GRAND RAPIDS
668 3 MILE ROAD NW
GRAND RAPIDS, MI 49504
PHONE: 616-785-1784
FAX: 616-785-1788

MINNESOTA
MINNEAPOLIS
21080 134TH AVE. NORTH
ROGERS, MN 55374
PHONE: 763-428-3633
FAX: 763-428-4551

MISSOURI
ST LOUIS
422 INDUSTRIAL DRIVE
MARYLAND HEIGHTS, MO 63043
PHONE: 314-298-1800
FAX: 314-298-7660

KANSAS CITY
1501 BEDFORD AVENUE
NORTH KANSAS CITY, MO 64116
PHONE: 816-587-0272
FAX: 816-587-3735

NEW YORK
AUBURN
ONE ELLIS DRIVE
AUBURN, NY 13021
PHONE: 315-255-3403
FAX: 315-253-9923

NORTH CAROLINA
GREENSBORO
1220 ROTHERWOOD ROAD
GREENSBORO, NC 27406
P O BOX 16500
GREENSBORO, NC 27416
PHONE: 336-272-6104
FAX: 336-273-6628

OHIO
CINCINNATI
2929 CRESCENTVILLE ROAD
WEST CHESTER, OH 45069
PHONE: 513-771-2600
FAX: 513-772-2219

CLEVELAND
8929 FREEWAY DRIVE
MACEDONIA, OH 44056
PHONE: 330-468-4777
FAX: 330-468-4778

OKLAHOMA
TULSA
2 EAST DAWES
BIXBY, OK 74008
PHONE: 918-366-9320
FAX: 918-366-9338

OREGON
PORTLAND
20393 SW AVERY COURT
TUALATIN, OR 97062
PHONE: 503-691-9010
FAX: 503-691-9012

PENNSYLVANIA
PHILADELPHIA
1035 THOMAS BUSCH
MEMORIAL HIGHWAY
PENNSAUKEN, NJ 08110
PHONE: 856-661-1442
FAX: 856-663-6363

PITTSBURGH
616H BEATTY ROAD
MONROEVILLE, PA 15146
PHONE: 412-380-7244
FAX: 412-380-7250

TENNESSEE
MEMPHIS
4000 WINCHESTER ROAD
MEMPHIS, TN 38118
PHONE: 901-365-2020
FAX: 901-365-3914

TEXAS
HOUSTON
4647 PINE TIMBERS
SUITE # 135
HOUSTON, TX 77041
PHONE: 713-895-7062
FAX: 713-690-4540

DALLAS
3040 QUEBEC
DALLAS, TX 75247
PHONE: 214-634-7271
FAX: 214-634-8874

UTAH
SALT LAKE CITY
2230 SOUTH MAIN STREET
SALT LAKE CITY, UT 84115
PHONE: 801-832-0127
FAX: 801-832-8911

WISCONSIN
MILWAUKEE
2725 SOUTH 163RD STREET
NEW BERLIN, WI 53151
PHONE: 262-784-5940
FAX: 262-784-1215

INTERNATIONAL SALES
FORT SMITH, AR
P O BOX 2400
FORT SMITH, AR 72902
PHONE: 479-646-4711
FAX: 479-648-5895

CANADA
EDMONTON, ALBERTA
4053-92 STREET
EDMONTON, ALBERTA T6E 6R8
PHONE: 780-434-4900
FAX: 780-438-2600

OAKVILLE, ONTARIO
2750 COVENTRY ROAD
OAKVILLE, ONTARIO L6H 6R1
PHONE: 905-829-3301
FAX: 905-829-3302

MONTREAL, QUEBEC
1844 WILLIAM STREET
MONTREAL, QUEBEC H3J 1R5
PHONE: 514-933-2711
FAX: 514-933-8639

VANCOUVER,
BRITISH COLUMBIA
1538 KEBET WAY
PORT COQUITLAM, BC V3C 5M5
PHONE 604-421-2822
FAX: 604-421-3113

WINNIPEG, MANITOBA
54 PRINCESS STREET
WINNIPEG, MANITOBA R3B 1K2
PHONE: 204-942-5205
FAX: 204-956-4251

AUSTRALIA
UNIT 3, 6 STANTON ROAD
SEVEN HILLS, NSW 2147,
AUSTRALIA
PHONE: (61) (2) 9674 5455
FAX: (61) (2) 9674 2495

UNIT 8, 5 KELLETTS ROAD
ROWVILLE, VICTORIA, 3178
AUSTRALIA
PHONE: (61) (3) 9753 4355
FAX: (61) (3) 9753 4366

AMÉRICA DEL SUR
APTDO. 9109 0818 ZONA 6
BETHANIA,
CIUDAD DE PANAMÁ, PANAMÁ
PHONE: +507 261-5347
FAX: +507 261-5355

CENTRO AMÉRICA Y CARIBE
RESIDENCIAL PINARES DE SUIZA
POL. 15 #44,
NVA. SAN SALVADOR, EL
SALVADOR
PHONE: +503 2288-1519
FAX: +503 2288-1518

CHINA
SHANGHAI JIAHUA BUSINESS CENTER
ROOM NO. A-8421
808 HONG QIAO ROAD
SHANGHAI 200030
PHONE: 86-21-64473060
FAX: 86-21-64078620

GERMANY
DIESELSTRASSE 22
D-85551 KIRCHHEIM
MUNICH, GERMANY
PHONE: +49 89 90 5080
FAX: +49 89 90 50 8492

INDIA
14, COMMERCE AVENUE
MAHAGANESH COLONY
PAUD ROAD
PUNE - 411 038
MAHARASHTRA, INDIA
PHONE: 91 20 25 45 95 31
FAX: 91 20 25 45 95 30

ITALY
BALDOR ASR AG
SUCCURSALE DI MENDRISIO
VIA BORROMINI, 20A
CH-6850 MENDRISIO
SWITZERLAND
PHONE: 0041 91 640 99 50
FAX: 0041 91 630 26 33

JAPAN
DIA BLDG 802,
2-21-1 TSURUYA-CHO,
KANAGAWA-KU
YOKOHAMA, 221-0835, JAPAN
PHONE: 81-45-412-4506
FAX: 81-45-412-4507

KOREA
ROOM 208-37
INCHEON INDUSTRIAL GOODS
CIRCULATING CENTER
SONGHYEON 3-DONG, DONG-GU
INCHEON, KOREA, 401-705
PHONE: 82 32 588 3253
FAX: 82 32 588 3254

MÉXICO
KM. 2.0 BLVD. AL AEROPUERTO
LEÓN 37545, GUANAJUATO,
MÉXICO
PHONE: 52 477 761 2030
FAX: 52 477 761 2010

MIDDLE EAST & NORTH AFRICA
VSE INTERNATIONAL CORP.
3233 NORTH ARLINGTON HEIGHTS
SUITE 100W
ARLINGTON HEIGHTS, IL 60004
PHONE: 847 590 5547

SINGAPORE
51 KAKI BUKIT ROAD 2
K B WAREHOUSE COMPLEX
SINGAPORE 417863
PHONE: (65) 6 744 2572
FAX: (65) 6 747 1708

SWITZERLAND
POSTFACH 73
SCHUTZENSTRASSE 59
CH-8245 FEUERTHALEN
SWITZERLAND
PHONE: +41 52 647 4700
FAX: +41 52 659 2394

TAIWAN
4F, NO. 25, SEC. 1,
TUNHUA S ROAD,
TAIPEI 10557, TAIWAN, R.O.C.
PHONE: (886-2) 2577-4352
FAX: (886-2) 2577-4157

UNITED KINGDOM
6 BRISTOL DISTRIBUTION PARK
HAWKLEY DRIVE
BRISTOL BS32 0BF U.K.
PHONE: +44 1454 85 9000
FAX: +44 1454 85 9001

WARNING:
CALIFORNIA PROPOSITION 65 WARNING:
Engine exhaust from this product contains chemicals known to the state of California to cause cancer, birth defects and other reproductive harm.

WARNING:
CALIFORNIA PROPOSITION 65 WARNING:
Battery posts, terminals and related accessories are known to the state of California to cause cancer, birth defects and other reproductive harm.

BALDOR®

BALDOR ELECTRIC COMPANY
P.O. Box 2400
Ft. Smith, AR 72902-2400
(479) 646-4711
Fax (479) 648-5792
www.baldor.com

