



# **COBALT HF-CNTL-PBS-02**

## **RFID CONTROLLER**

---

*High Frequency Passive Radio Frequency Identification Controller*

# **INSTALLATION GUIDE**

---

*How to Install and Setup*

*Cobalt HF-CNTL-PBS-02 RFID Controller*

**HF-CNTL-PBS-02 INSTALLATION GUIDE – REV. 03**

*Copyright © 2010 Datalogic Automation S.r.l., all rights reserved*

## **REGULATORY COMPLIANCE**

### **FCC COMPLIANCE**

Modifications or changes to this equipment without the expressed written approval of Datalogic could void the authority to use the equipment.

This device complies with PART 15 of the FCC Rules.

Operation is subject to the following two conditions: (1) This device may not cause harmful interference, and (2) this device must accept any interference that may cause undesired operation.

FCC ID : E36-0002

#### **NOTE:**

This equipment has been tested and found to comply with the limits for a Class B digital device, pursuant to Part 15 of the FCC Rules. These limits are designed to provide reasonable protection against harmful interference in a residential installation. This equipment generates, uses and can radiate radio frequency energy and, if not installed and used in accordance with the instructions, may cause harmful interference to radio communications. However, there is no guarantee that interference will not occur in a particular installation. If this equipment does cause harmful interference to radio or television reception, which can be determined by turning the equipment off and on, the user is encouraged to try to correct the interference by one or more of the following measures:

- Reorient or relocate the receiving antenna.
- Increase the separation between the equipment and receiver.
- Connect the equipment into an outlet on a circuit different from that to which the receiver is connected.
- Consult the dealer or an experienced radio/TV technician for help.

## **RADIO COMPLIANCE**

### **ENGLISH**

Contact the competent authority responsible for the management of radio frequency devices of your country to verify any possible restrictions or licenses required. Refer to the web site:

<http://ec.europa.eu/enterprise/sectors/rtte/> for further information.

### **ITALIANO**

Prendi contatto con l'autorità competente per la gestione degli apparati a radio frequenza del tuo paese, per verificare eventuali restrizioni o licenze. Ulteriori informazioni sono disponibili sul sito:

<http://ec.europa.eu/enterprise/sectors/rtte/>

### **FRANÇAIS**

Contactez l'autorité compétente en la gestion des appareils à radio fréquence de votre pays pour vérifier d'éventuelles restrictions ou licences. Pour tout renseignement vous pouvez vous adresser au site web:

<http://ec.europa.eu/enterprise/sectors/rtte/>

### **DEUTSCH**

Wenden Sie sich an die für Radiofrequenzgeräte zuständige Behörde Ihres Landes, um zu prüfen ob es Einschränkungen gibt, oder eine Lizenz erforderlich ist. Weitere Informationen finden Sie auf der Web Seite:

<http://ec.europa.eu/enterprise/sectors/rtte/>

### **ESPAÑOL**

Contacta la autoridad competente para la gestión de los dispositivos de radio frecuencia de tu país, para verificar cualesquiera restricciones o licencias posibles requerida. Además se puede encontrar mas información en el sitio Web:

<http://ec.europa.eu/enterprise/sectors/rtte/>



## **POWER SUPPLY**

This product is intended to be installed by Qualified Personnel only.

This device is intended to be supplied by a UL Listed or CSA Certified Power Unit with «Class 2» or LPS power source

# CHAPTER 1: CONTROLLER INFORMATION

## 1.1 HF-CNTL-PBS-02 OVERVIEW

Welcome to the **Cobalt HF-CNTL-PBS-02 RFID Controller – Installation Guide**, this document will assist you in the installation and setup of the Cobalt HF-CNTL-PBS-02 RFID Controller.

The Cobalt HF-CNTL-PBS-02 is a feature-rich, high frequency, Radio-Frequency Identification device that provides read/write RFID data transmission and control solutions to shop floor, item-level tracking and material handling applications.

The controller is designed to be compact, rugged and reliable, in order to meet and exceed the requirements of the industrial automation industry.

### 1.1.1 Package Contents

Unpack the Cobalt Controller hardware and accessories. Retain the original shipping carton and packing material in case any items need to be returned. Inspect each piece carefully, if an item appears to be damaged, notify your EMS product distributor.

The *Cobalt HF-CNTL-PBS-02 RFID Controller* product package contains the following components:

PART NUMBER	QTY	DESCRIPTION
HF-CNTL-PBS-02	1	Cobalt HF-Series RFID Controller (-PBS)
17-3126	1	HF-CNTL-PBS-02 Installation Guide
20-1950	2	Screw (Socket Head Cap, M5 x 20mm, Hex #4, 18-8 SS)
20-3915	2	Washer (Spring Lock, M5, 18-8 SS)
69-1289	1	Wrench Tool (Hex #4, 4mm, L-key)
00-3000	1	Cobalt HF-Series Configuration Tag
CBL-1487	1	Field Mountable Connector (Straight, 5-pos, Female, M12 - for connecting power)

Table 1-1: HF-CNTL-PBS-02 - Package Contents

## 1.1.2 Power & Communications Interface

<b>Connection Type:</b>	Profibus	
<b>Communication Interface:</b>	Profibus - DP	
<b>Data Interface Connector:</b>	5-pin, male M12 Connector (for Profibus data)	5-pin, female M12 Connector (for Profibus data)
<b>Power Interface Connector:</b>	5-pin, Male, M12 (for power)	
<b>Additional Connector:</b>	8-pin, Male M12 Connector for RS232 configuration support	
<b>Maximum Cable Length:</b>	100m	

## 1.1.3 HF-CNTL-PBS-02 Controller Dimensions

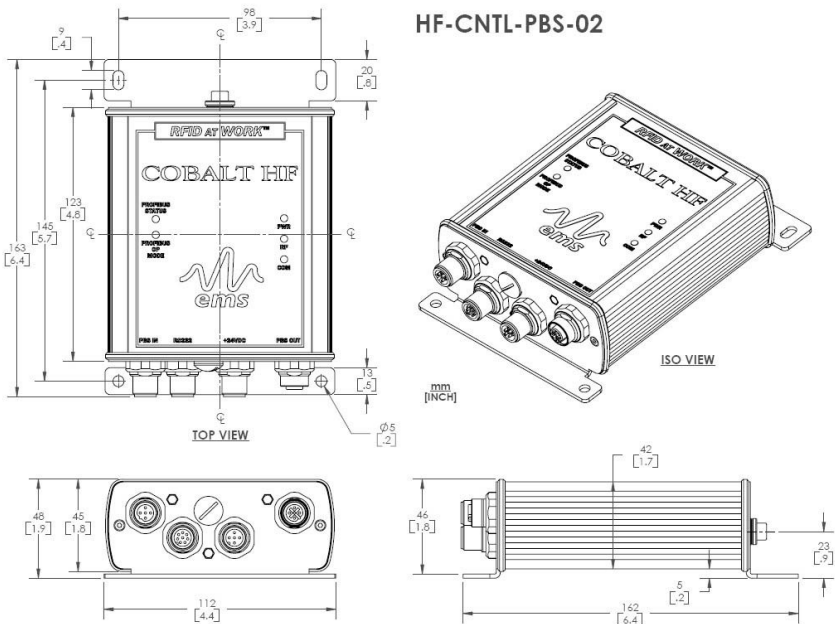

Figure 1-1: HF-CNTL-PBS-02 Controller Dimensions

## 1.2 COBALT HF-SERIES RFID ANTENNAS

The Cobalt HF product family currently includes four different RFID antenna models. Because Cobalt HF Antennas are designed with different dimensions, they each generate unique RF field pattern and read/write range.

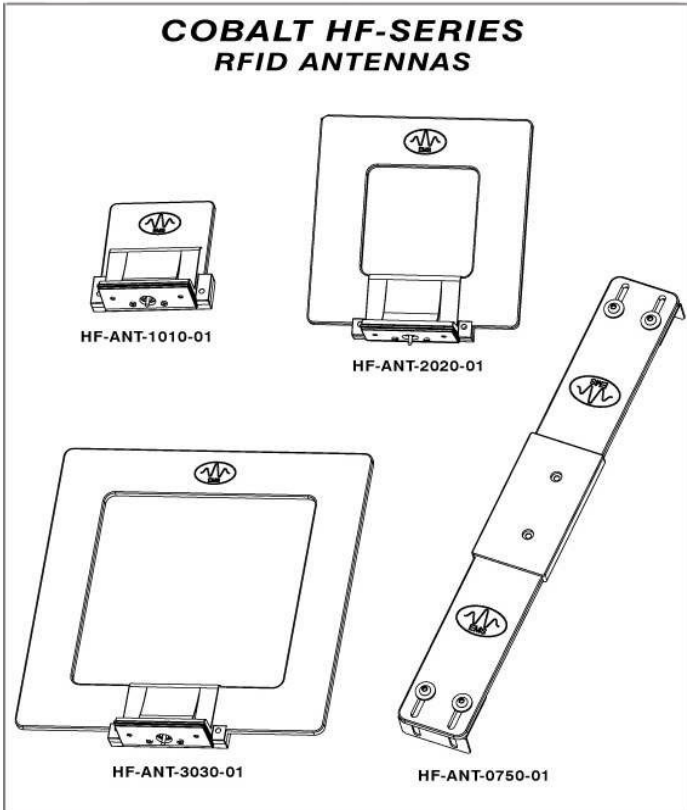

Figure 1-2: Cobalt HF-Series RFID Antennas

### COBALT HF RFID ANTENNAS – MODELS AND SIZES

ANTENNA MODEL	ANTENNA SIZE
HF-ANT-1010-01	10cm x 10cm
HF-ANT-2020-01	20cm x 20cm
HF-ANT-3030-01	30cm x 30cm
HF-ANT-0750-01	7cm x 50cm

Table 1-2: Cobalt HF RFID Antennas – Models and Sizes

## 1.2.1 HF-ANT-1010-01 Antenna Dimensions

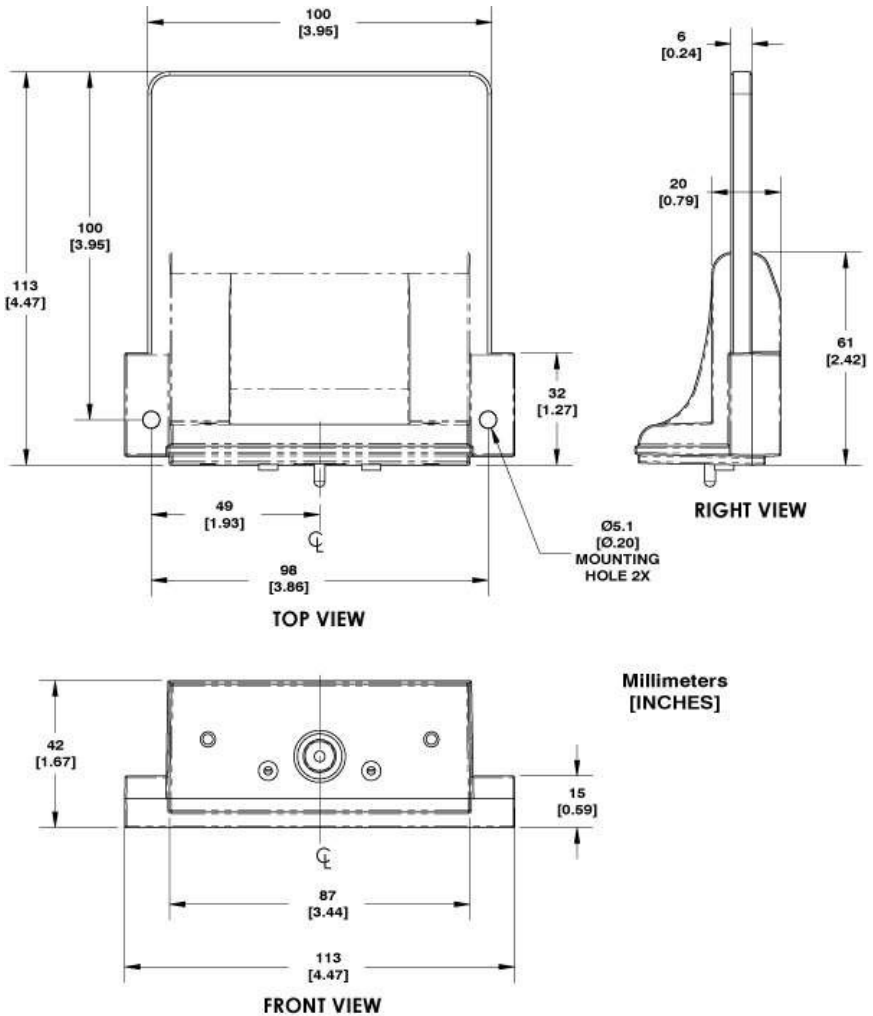

Figure 1-3: HF-ANT-1010-01 Antenna Dimensions

## 1.2.2 HF-ANT-2020-01 Antenna Dimensions

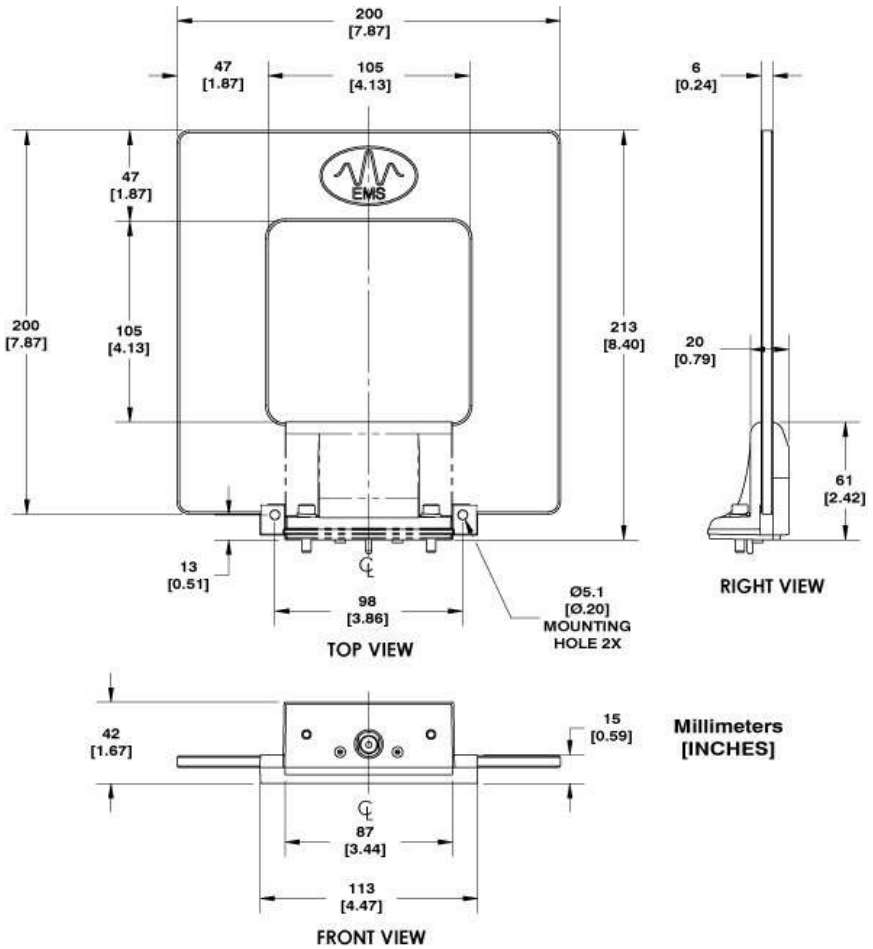

Figure 1-4: HF-ANT-2020-01 Antenna Dimensions



## 1.2.3 HF-ANT-3030-01 Antenna Dimensions

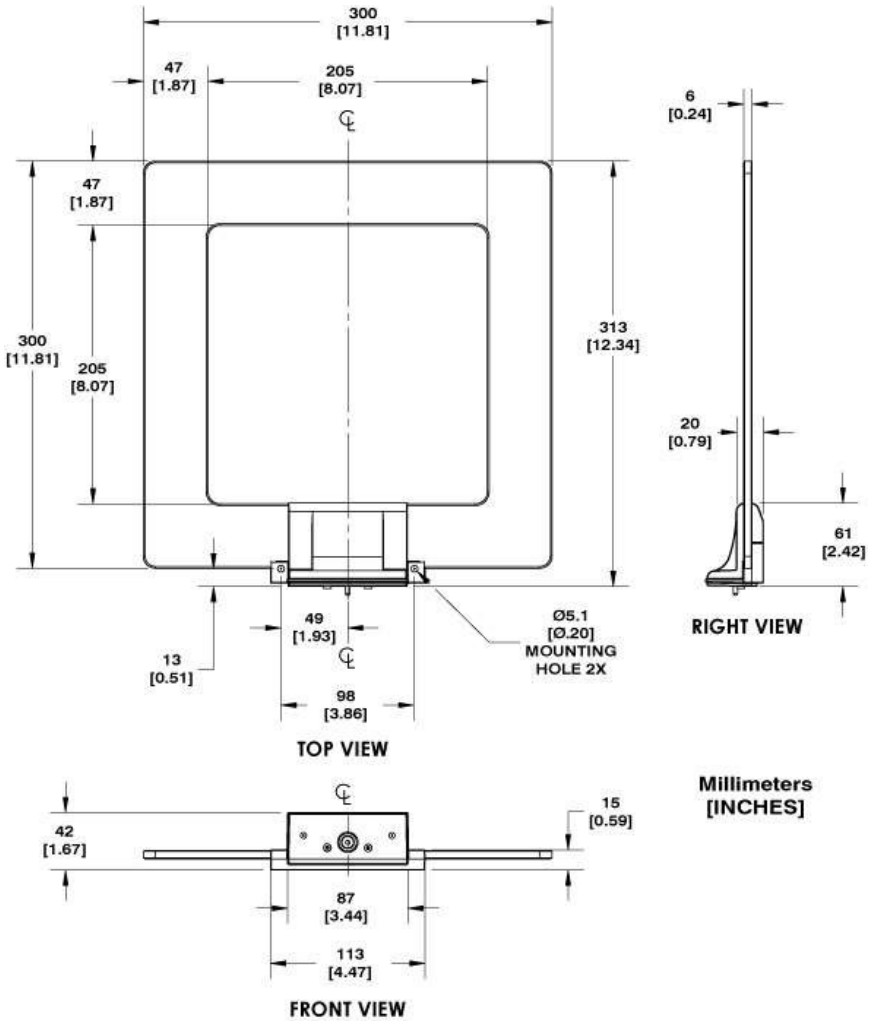

Figure 1-5: HF-ANT-3030-01 Antenna Dimensions

## 1.2.4 HF-ANT-0750-01 Antenna Dimensions

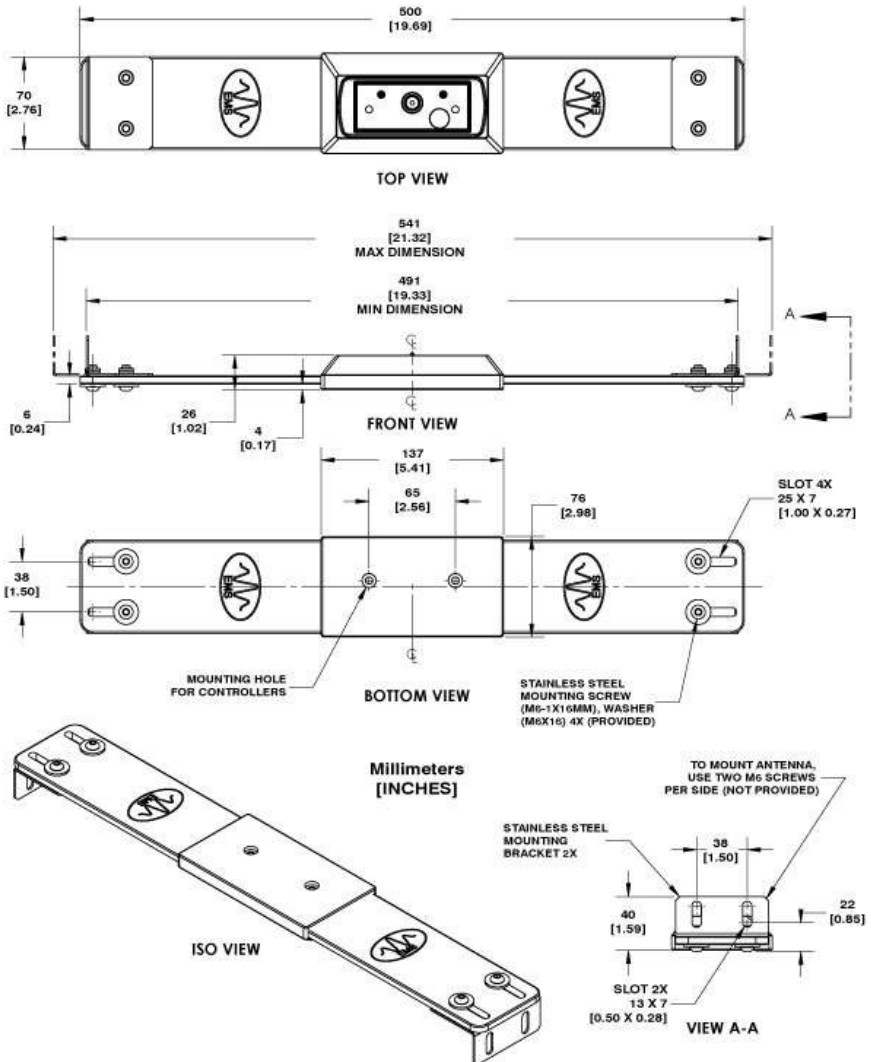

Figure 1-6: HF-ANT-0750-01 Antenna Dimensions

# CHAPTER 2: CONTROLLER INSTALLATION

## 2.1 PREPARING FOR INSTALLATION

### 2.1.1 Power Requirements

The Cobalt Controller requires an electrical DC supply voltage. See Technical Specifications for details. Use a dedicated and regulated power supply connected to a suitable AC power source that is capable of delivering these requirements. Do not apply power until the entire system is wired and checked.

### 2.1.2 Installation Guidelines

- RF performance and read/write range can be negatively impacted by the proximity of metallic objects. Avoid mounting the antenna within 15cm (6 inches) of any metallic object or surface.
- Do not route cables near unshielded cables or near wiring carrying high voltage or high current. Cross cables at perpendicular intersections and avoid routing cables near motors and solenoids.
- Avoid mounting the controller near sources of EMI (electro-magnetic interference) or near devices that generate high ESD (electro-static discharge) levels.
- If electrical interference is encountered (as indicated by a reduction in read/write performance), relocate the controller to an area free from potential sources of interference.
- Conduct a test phase where you will construct a small scale, independent network that includes only the essential devices required to test your RFID application. To avoid possible interference with other devices, do not initially connect your RFID testing environment to an existing local area network.
- Always use adequate ESD prevention measures to dissipate potentially high voltages.

## 2.2 CONNECTING THE ANTENNA

Cobalt HF-Series RFID Antennas mount directly to the top of the Cobalt HF-Series RFID Controller's housing. The antenna is first attached to the RF port on the controller and is then fastened to the controller's housing using the two M5 screws and matching spring lock washers included with each Cobalt HF-Series RFID Controller. Use the provided 4mm hex key wrench to tighten both M5 screws.

### ***TORQUE SPECIFICATION***

Screws should be tightened to the following torque setting:

**1.7 Nm or 15 lbs / inch  $\pm$  10%**

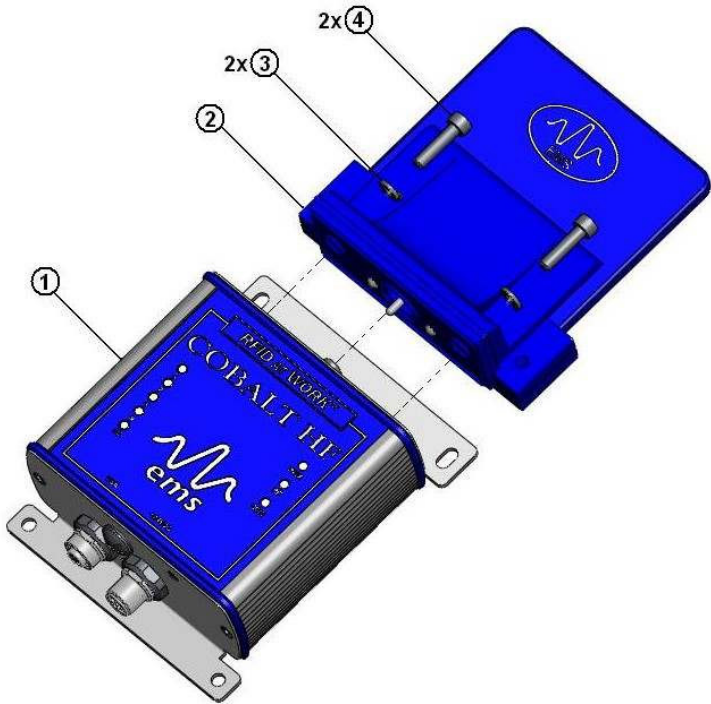

ITEM	QTY	DESCRIPTION
1	1	Cobalt Controller (HF-CNTL-PBS-02)
2	1	Cobalt Antenna (HF-ANT-1010-01)
3	2	Washer (Spring Lock, M5, 18-8 SS)
4	2	Screw (Socket Head Cap, M5 X 20mm, 18-8 SS)

## 2.2.1 Minimum Distance between Antennas

When installing multiple Cobalt HF-Series Controllers/Antennas, refer to the table below to determine the recommended minimum distance to maintain between adjacent Cobalt Antennas.

<b>COBALT ANTENNA</b>	<b>-1010</b>	<b>-2020</b>	<b>-3030</b>	<b>-0750</b>
<b>-1010</b>	60cm	75cm	90cm	50cm
<b>-2020</b>	75cm	90cm	1.2m	65cm
<b>-3030</b>	90cm	1.2m	2m	90cm
<b>-0750</b>	50cm	65cm	90cm	50cm

*Table 2-1: Minimum Distance between Antennas*

For example, an HF-ANT-3030 RFID Antenna and an HF-ANT-1010 RFID Antenna should be located no closer than 90 centimeters apart.

## 2.3 INSTALLING THE HF-CNTL-PBS-02

Note: review **Section 2.1.2: “Installation Guidelines”** prior to installing the controller.

1. Attach the Cobalt HF Antenna to the Cobalt HF Controller as per the instructions in **Section 2.2: “Connecting the Antenna.”**
2. Select a suitable location for the Cobalt HF Controller/Antenna. If necessary, fabricate mounting brackets from durable plastic.
3. Fasten combined controller and antenna to your mounting fixture using two M5 (#10) diameter screws (not included). Pass screws through antenna’s mounting holes and secure them with appropriate washers and nuts. Tighten screws to 1.7 Nm or 15 lbs per inch  $\pm$  10%.
4. Connect the three wires from your power supply to pins 1-3 on the 5-pin, female, M12 connector (**P/N: CBL-1487** included).
5. Attach the **CBL-1487** connector to the 5-pin, male, M12 connector on the Cobalt Controller.
6. Attach a Profibus-compatible data cable (**P/N: CBL-1438-XX** not included) to the 5-pin, male M12 interface connector on the Cobalt. Connect the other end of this cable to your Profibus network.
7. Turn your power supply ON. The green **PWR (power) LED** on the Cobalt will illuminate. After the boot process is complete, The two “Profibus” **LEDs** on the controller may appear green or off depending on the status of the connection with your Profibus network.

### OPTIONAL STEPS FOR ADDITIONAL CONFIGURATION

**Steps 9 through 11** below are considered optional and only need to be completed by users that wish to modify their Cobalt controller’s internal configuration.

8. To modify the controller’s internal configuration, connect an 8-pin, RS232-compatible, serial interface cable to the 8-pin, male M12 interface connector on the Cobalt. Connect the other end of this cable to a COM port on your host computer.
9. On the host computer, set COM port parameters to the following values:

COM PORT PARAMETER	DEFAULT VALUE
<b>Baud</b>	9600
<b>Data Bits</b>	8
<b>Stop Bits</b>	1
<b>Parity</b>	None
<b>Handshaking</b>	None

*Table 2-2: HF-CNTL-PBS-02 COM Port Default Settings*

- Download the **Cobalt Dashboard Utility** from [www.ems-rfid.com](http://www.ems-rfid.com) and install the software on your host computer. Use the *Dashboard Utility* to connect, via RS232 serial connection, to the controller. You will then be able to use the Cobalt HF Dashboard Utility to configure the Cobalt and send RFID commands for testing purposes.

## 2.4 CABLING INFORMATION

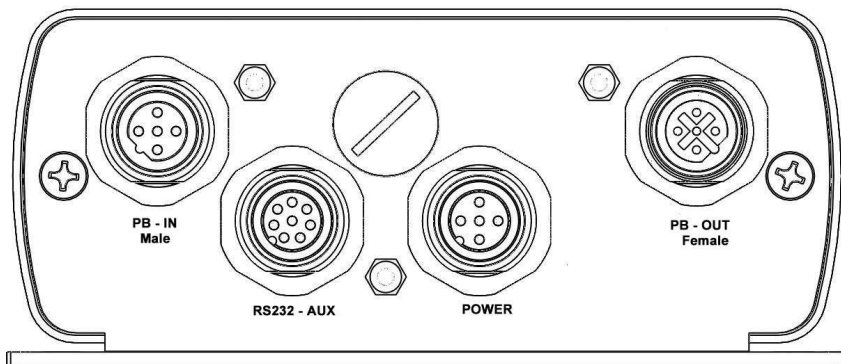
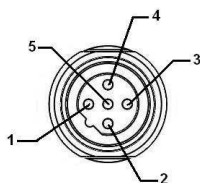

Figure 2-1: 5-Pin, Male, M12 Connector (Profibus); 8-Pin, Male M12 Connector (for RS232 configuration); 5-Pin, Male, M12 Connector (Power) & 5-Pin, Female, M12 Connector (Profibus)

### 5-PIN MALE M12 CONNECTOR – PROFIBUS



PIN #	DESCRIPTION
1	NOT CONNECTED
2	BUS – A
3	NOT CONNECTED
4	BUS – B
5	SHIELD

Table 2-4: 5-Pin, Male, M12 Connector (Profibus)

### 5-PIN MALE M12 CONNECTOR - POWER

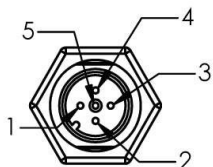

PIN #	DESCRIPTION
1	NOT CONNECTED
2	+VDC POWER
3	0VDC (POWER GROUND)
4	NOT CONNECTED
5	NOT CONNECTED

Table 2-5: 5-Pin, Male, M12 Connector (Power)



## 8-PIN MALE M12 CONNECTOR – RS232 CONFIGURATION

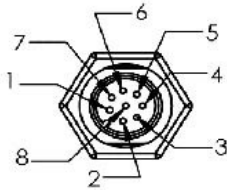

PIN #	DESCRIPTION
1	NOT CONNECTED
2	NOT CONNECTED
3	NOT CONNECTED
4	NOT CONNECTED
5	NOT CONNECTED
6	RX (connects to PC TX)
7	TX (connects to PC RX)
8	SGND (SIGNAL GROUND)

Table 2-6: 8-Pin, Male M12 Connector (for RS232 configuration)

## 5-PIN FEMALE M12 CONNECTOR - PROFIBUS

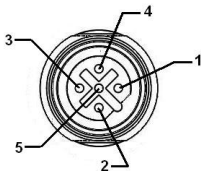

PIN #	DESCRIPTION
1	5 VDC
2	BUS – A
3	GROUND
4	BUS – B
5	SHIELD

Table 2-7: 5-Pin, Female, M12 Connector (Profibus)

## HF-CNTL-PBS-02 CABLING PART NUMBERS

**CBL-1438-XX**: (Cable Profibus 12MM M/F)

(XX = Cable Length in Meters)

## 2.4.1 Profibus Interface Cable Schematic

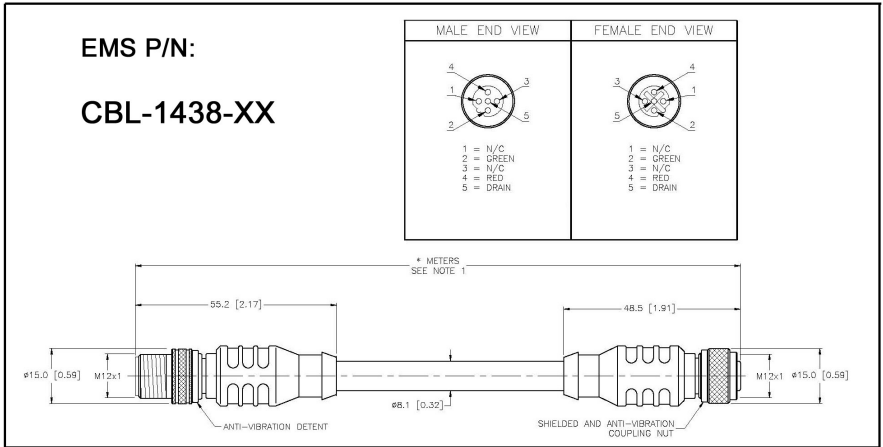

Figure 2-2: CBL-1438-XX (Cable Profibus 12MM, 5-Pin, M/F)

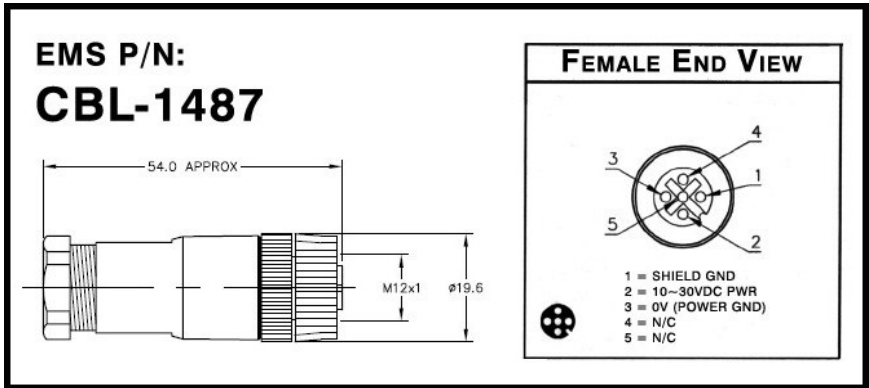

Figure 2-3: CBL-1487 (5-Pin, Female, M12, Straight Field Mountable Connector)

**ATTENTION:**

For operating instructions for the *HF-CNTL-PBS-02 RFID Controller*, refer to the:

***Cobalt HF-Series RFID Controllers – Operator’s Manual***

available online at: [www.ems-rfid.com](http://www.ems-rfid.com).

Also available online at [www.ems-rfid.com](http://www.ems-rfid.com) is Escort Memory Systems’ **Cobalt Dashboard™** software utility. The RFID Dashboard is a Windows-based application that provides users with complete control over their EMS RFID hardware. Users can monitor their entire RFID system - from the tag level, to the RFID Controller, to the Host.

# CHAPTER 3: TECHNICAL SPECIFICATIONS

## 3.1 COBALT HF CONTROLLERS

### *ELECTRICAL*

DC input Voltage Range	12-30VDC
DC Input Current	500-300mA

### *RADIO*

Frequency	13,56MHz
Air Interface	ISO15693, ISO14443
Conducted Output Power	1W

### *COMMUNICATION*

HF-CNTL-PBS-02	PROFIBUS-DP Max cable length : 100m
----------------	--

### *MECHANICAL*

Dimensions	163mm (6.4 inches) H x 112mm (4.4 inches) L x 46mm (1.8 inches) W
Weight	0.56 Kg (0.97 lb., 560 grams)
Enclosure	Powder-coated Aluminum

## ***ENVIRONMENTAL***

<b>Operating Temperature</b>	-20° to 50°C ( -4° to 122°F )
<b>Storage Temperature</b>	-20° to +70°C ( -4° to 158°F )
<b>Humidity</b>	90% non-condensing
<b>Protection Class</b>	IP65

## **3.2 HF ANTENNAS**

### ***ELECTRICAL***

<b>All models</b>	
<b>Frequency</b>	13,56MHz
<b>Input Impedence</b>	50 ohm
<b>Gain HF-ANT-1010-1</b>	-36,6dBi
<b>Gain HF-ANT-2020-1</b>	-26,3dBi
<b>Gain HF-ANT-3030-1</b>	-22,9dBi
<b>Gain HF-ANT-0750-1</b>	-37,8dBi

## ***MECHANICAL***

<b>HF-ANT-1010-1</b>	
<b>Dimensions</b>	100x100x42mm ( 3.95x3.95x1.67in)
<b>Weight</b>	280g ( 9.88oz )
<b>HF-ANT-2020-1</b>	
<b>Dimensions</b>	200x200x42mm ( 7.87x7.87x1.67in)
<b>Weight</b>	500g ( 17.64 oz )
<b>HF-ANT-3030-1</b>	
<b>Dimensions</b>	300x300x42mm ( 11.81x11.81x1.67 oz )
<b>Weight</b>	740g ( 26.10 oz )
<b>HF-ANT-0750-1</b>	
<b>Dimensions</b>	70x500x42mm ( 2.76x19.69x1.59in )
<b>Weight</b>	635g ( 22.4 oz )

NOTE : This device and its antenna are intended for idoor use only

NOTE : Specifications are subject to change without notice

## **WARRANTY**

Datalogic Automation warrants that all products of its own manufacturing conform to Datalogic Automation's specifications and are free from defects in material and workmanship when used under normal operating conditions and within the service conditions for which they were furnished. The obligation of Datalogic Automation hereunder shall expire one (1) year after delivery, unless otherwise specified, and is limited to repairing, or at its option, replacing without charge, any such product, which in Datalogic Automation's sole opinion proves to be defective within the scope of this Warranty. In the event Datalogic Automation is not able to repair or replace defective products or components within a reasonable time after receipt thereof, Buyers shall be credited for their value at the original purchase price. Datalogic Automation must be notified in writing of the defect or nonconformity within the warranty period and the affected product returned to Datalogic Automation factory or to an authorized service center within thirty (30) days after discovery of such defect or nonconformity. Shipment shall not be made without prior authorization by Datalogic Automation.

This is Datalogic Automation's sole warranty with respect to the products delivered hereunder. No statement, representation, agreement or understanding oral or written, made by an agent, distributor, representative, or employee of Datalogic Automation which is not contained in this warranty, will be binding upon Datalogic Automation, unless made in writing and executed by an authorized Datalogic Automation employee.

Datalogic Automation makes no other warranty of any kind what so ever, expressed or implied, and all implied warranties of merchantability and fitness for a particular use which exceed the aforementioned obligation are here by disclaimed by Datalogic Automation and excluded from this agreement. Under no circumstances shall Datalogic Automation be liable to Buyer, in contract or in tort, for any special, indirect, incidental, or consequential damages, expenses, losses or delay however caused. Equipment or parts that have been subjected to abuse, misuse, accident, alteration, neglect, unauthorized repair or installation are not covered by warranty. Datalogic Automation shall make the final determination as to the existence and cause of any alleged defect. No liability is assumed for expendable items such as lamps and fuses. No warranty is made with respect to equipment or products produced to Buyer's specification except as specifically stated in writing by Datalogic Automation in the contract for such custom equipment. This warranty is the only warranty made by Datalogic Automation with respect to the goods delivered hereunder, and may be modified or amended only by a written instrument signed by a duly authorized officer of Datalogic Automation and accepted by the Buyer.