

1

BALLUFF
sensors worldwide

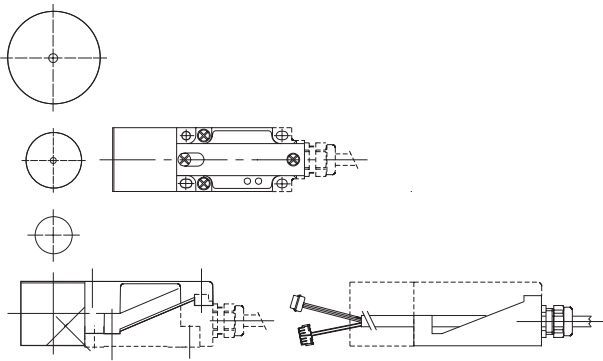

Manual

Electronic Identification Systems BIS
Compact Processor
BIS L-405-033-00_-05-MU
BIS L-405-037-00_-05-MU

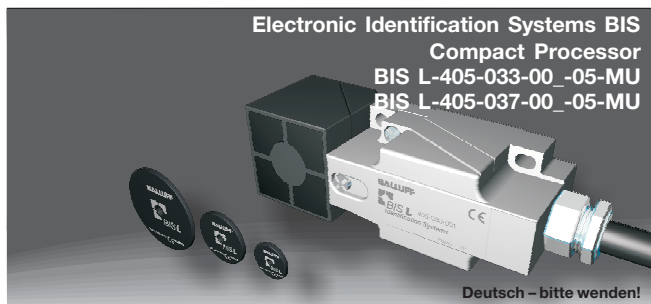

Deutsch – bitte wenden!

2

No. 834 487 D/E • Edition 0709
Specifications subject to change.
Replaces edition 0605.

Balluff GmbH
Schurwaldstrasse 9
73765 Neuhausen a.d.F.
Germany
Phone +49 7158 173-0
Fax +49 7158 5010
balluff@balluff.de

■ www.balluff.com

Contents

| | |
|---|-------|
| Safety Notes | 4 |
| Introduction BIS L-405 Identification System | 5/6 |
| Application BIS L-405 Processor | 7-12 |
| CRC data check with BIS L-405-037-... Processor | 13/14 |
| Installation L-405 | 15/16 |
| Installation L-405-...-001-..... | 17 |
| Installation L-405-...-002-..... | 18 |
| Installation L-405-...-003-..... | 19 |
| Installation L-405-...-004-..... | 20 |
| Installation | 21/22 |
| Reorienting and Rotating the Read Head | 23 |
| Connection Diagrams | 24 |
| Technical Data | 25 |
| Ordering Information | 26 |
| Appendix, ASCII Table | 27 |

Safety Notes

| | |
|-----------------------------------|--|
| Proper use and operation | BIS L-4_ _ processor together with the other BIS L system components comprise the Identification System and may only be used for this purpose in industrial applications corresponding to Class A of the EMC Directive. |
| Installation and operation | Installation and operation are permitted by trained specialists only. Unauthorized modifications and improper use will result in loss of the right to make warranty and liability claims. When installing the processor, follow exactly the connection diagrams provided later in this document. Take special care when connecting the processor to external controllers, especially with respect to the selection and polarity of the connections including the power supply. Only approved power supplies may be used. For specific information, see the Technical Data section. |
| Deployment and inspection | When deploying the identification system, all relevant safety regulations must be followed. In particular, measures must be taken to ensure that any defect in the identification system does not result in a hazard to persons or equipment. This includes maintaining the permissible ambient conditions and regular inspection for proper function of the identification system and all the associated components. |
| Malfunction | At the first sign that the identification system is not working properly, it should be taken out of service and guarded against unauthorized use. |
| Scope | This document applies to the processor BIS L-405-03_-00_-05-MU (Software version V1.2 and higher). |

Introduction BIS L-405 Identification System

This manual is intended to guide the user in installing and commissioning the components in the BIS L-405 identification system, so that start-up time is reduced to an absolute minimum.

| | |
|----------------------------------|---|
| Principle | The BIS L-405 identification system belongs to the category of read-only, non-contacting systems . This function enables applications in which information which has been pre-coded into the data carriers can be read out and used for further processing. |
| Applications | The main areas of application include <ul style="list-style-type: none"> - in production for controlling material flow (e.g., for part-specific processes), in workpiece transport using conveying systems, for obtaining safety-relevant data, - in process materials organization. |
| System component function | The processor and the read head form a compact unit which is contained in a plastic housing. The data carrier represents an independent unit. It does not require line-fed power and receives its energy from the integrated read head in the BIS L-405 identification system. The read head continuously sends a carrier signal which supplies the data carrier as soon as the latter has reached the required distance from the read head. The read process takes place during this phase. The data are output in 8-bit blocks over 8 parallel data lines and made available to the host system. These host systems may be: <ul style="list-style-type: none"> - a control computer (e.g., industrial PC) having a parallel port, or - a programmable logic controller (PLC). |

Introduction BIS L-405 Identification System

System components
The main components of the BIS L-405 identification system are

- the processor with integrated read head, and
- the data carrier(s).

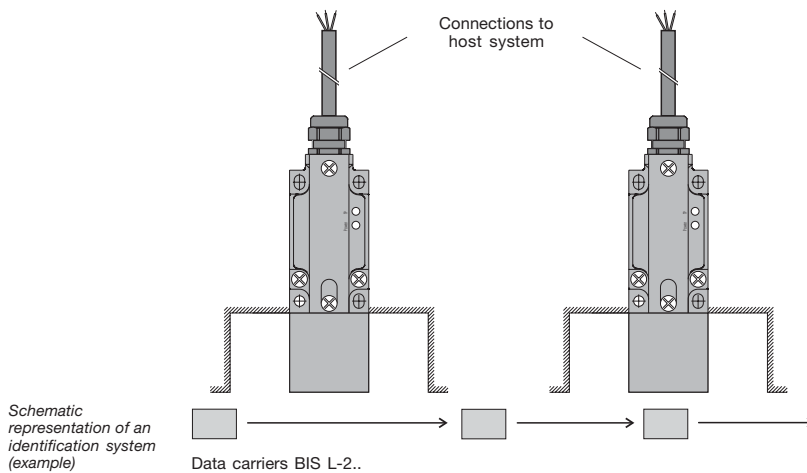

Application BIS L-405-... Processor

Signal description

Tag Present (TP): Indicates a data carrier in the field.
 Address (ADR): Signal change outputs the next data carrier address.
 Strobe (STR): This signal acknowledges the data output on the parallel interface.
 ReStart: Deletes the data memory in the BIS L-405 and sets all data outputs to 0. The data carrier is then read again or, if no data carrier is present, only the data outputs are set to 0. This signal is also used to turn off the read antenna. If two read heads are installed close together and interfere with each other, this can deactivate one read head as long as the other needs to be available.
 D0..D7: Data outputs
 When supply voltage is applied, the data outputs are in an undefined state for approx. 100 ms. Then they switch to 0. The first byte cannot be read until the ADR signal changes.

Application BIS L-405-... Processor

Read 5 bytes

Detection of a new data carrier is indicated by the TP signal. The first data value is not output until the ADR input signal changes. Each time ADR changes, the value of the next address is given to the data outputs. As an acknowledgement of the data change, the processor inverts the STR signal. Once the last byte is output, a change in ADR is followed by a data value output of 0. Any further change to ADR does result in a change to the STR signal, but the data remain 0. This is how the end of data can be recognized. If the data carrier leaves the read head before all the data have been output, the data remain stored for a subsequent data read. Before a new data carrier is recognized by the read head, data transmission must have been completed.

If the next data carrier enters the read zone before the data have been picked up, the "Tag Present" (Overflow) LED will indicate this by flashing. The data from the new tag are not output, and a ReStart must be performed to resynchronize.

Timing

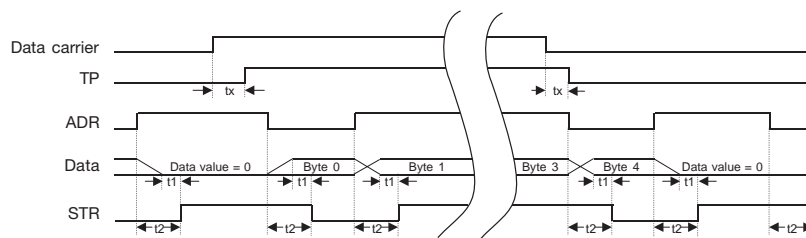

tx = Read time = 140 ms t1 = Data output before Strobe = 6 ms t2 = Response to address change ≤ 15 ms

Application BIS L-405-... Processor

Restart when data carrier is present

If a ReStart is detected while a data carrier is in the active zone of the read head, the data outputs are switched to 0 and acknowledged with STR. As soon as ReStart goes low again, first the STR signal is inverted as acknowledgement and the data carrier is read out again. From there the process is the same as for a newly detected data carrier.

With this function you can force a re-read of a data carrier.

Timing

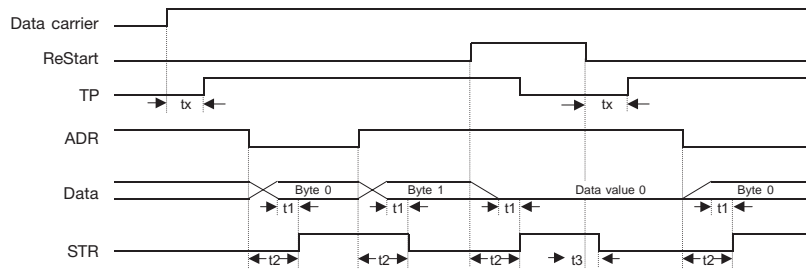

tx = Read time = 140 ms
 t1 = Data output before Strobe = 6 ms
 t2 = Response to address change ≤ 15 ms
 t3 = STR acknowledges ReStart finished = 7 ms

Application BIS L-405-... Processor

Restart with no data carrier present

If a ReStart is detected when there is no data carrier in front of the read head, the data outputs are switched to 0 and acknowledged with STR. The data from the last read data carrier are deleted from the data memory and can no longer be read out. As soon as ReStart is finished, a change in the STR signal acknowledges this.

You can use this function to re-synchronize data transmission.

Timing

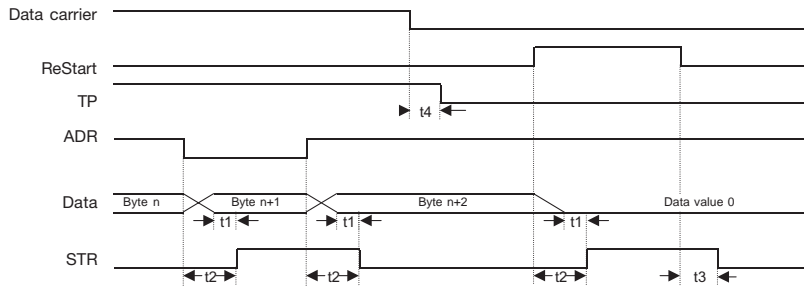

t1 = Data output before Strobe = 6 ms
 t2 = Response to address change ≤ 15 ms
 t3 = STR acknowledges ReStart finished = 7 ms
 t4 = Tag Present 0 after removing the data carrier ≤ 60 ms

Application BIS L-405-... Processor

Cable test

The cable test can be used to check the wiring of the outputs. "ReStart" is switched to "high" and acknowledged with STR. The first data output D0 is not switched until the ADR signal changes. Each time the ADR signal changes the next data output is switched. The STR signal is switched to acknowledge the data output change. Once the last data output D7 has been tested, a change in ADR results in the software version number (2 bytes) being output. Any further change to ADR does result in a change to the STR signal, but the data outputs remain at 0.

Timing

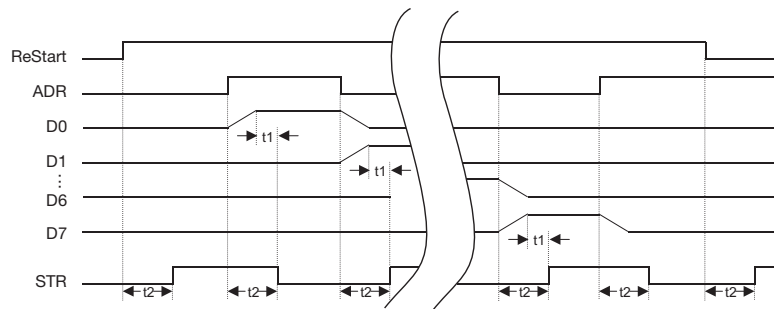

t1 = Data output before Strobe = 6 ms
t2 = Response to address change ≤ 15 ms

Application BIS L-405-... Processor

**Wiring up to 8
BIS L-405
processors in
parallel**

The data lines from up to 8 BIS L-405 processor can be connected in parallel. Since no data is output until there is a request ("ADR" signal), there is no signal collision among the processors. It is imperative that you communicate with only one of these processors and that the output protocol is completely finished before beginning communication with another processor. If the data lines are wired in parallel, be sure that the data lines have at least a 10 mA load. If necessary, install appropriate load resistors. If this recommendation is not followed, the signal change on the data lines can be falsified, resulting in incorrect data being sent.

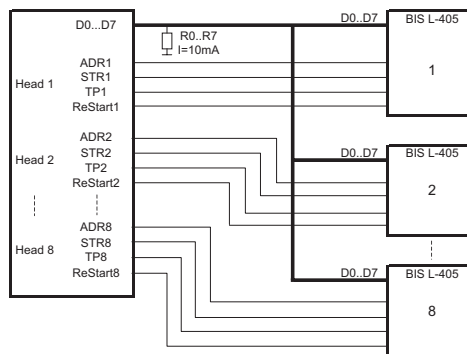

CRC data check with BIS L-405-037-... Processor

The BIS L-405-037-... processor checks for correctness of the data read using a CRC_16 checksum. This CRC_16 checksum is located in Byte 3 and Byte 4 of the data carrier. This ensures especially high data integrity.

Initialize data carrier

In order to use the CRC_16 procedure, data carriers of type BIS L-10_-05/L must first be initialized using a BIS L-60_ _ processor and the BISCOBRW.exe PC software. Only 3 bytes of user data are then available on the data carrier.

The BIS L-405-037-... processor can only be operated with initialized data carriers of type BIS L-10_-05/L.



Data carriers of type BIS L-10_-05/L should not be used with the BIS L-405-033-... processor, because there is no CRC-16 check.

CRC data check with BIS L-405-037-...

CRC error

If the BIS L-405-037... processor detects a data carrier with an incorrect CRC_16 checksum, the output TP remains Low. The output STR is inverted to indicate the CRC error. The "Tag present" LED flashes slowly. The incorrect data can only be retrieved by changing ADR (see p. 8). The processor sets the CRC_16 checksum to 0x00 0x00.

If you do not begin with retrieving the incorrect data, the new data will be output the next time a data carrier with a correct CRC_16 checksum is detected.

Timing

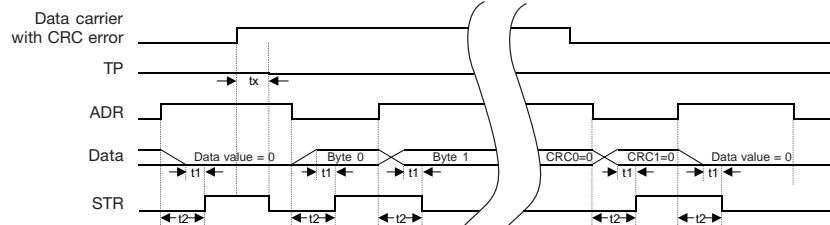

tx = Read time = 100 ms t1 = Data output before strobe = 6 ms t2 = Response to address change ≤ 15 ms

BIS L-405 Installation

Installation BIS L-405

When installing two BIS L-405 on a metal base, there is normally no mutual interference. If a metal frame is located in an unfavorable location, problems may result when reading out the data carriers. In this case the read distance will be reduced to 80 % of the maximum value.

Testing is recommended in critical applications!

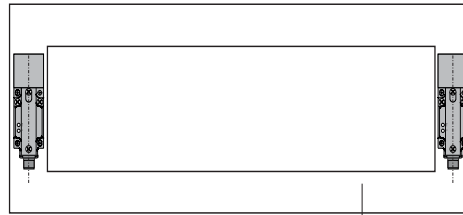

Metal frame

Once a data carrier has been processed in front of a read head, the next data carrier must wait 400 ms before being introduced into the active field. This can be implemented by means of a stopper. If a stopper is not used, there is a rule of thumb which takes into account the conveyor speed. Distance between the data carriers in m = (0.4 x conveyor speed in m/s) + 0.25 m.

Example: Conveyor speed = 1 m/s

Distance = (0.4 x 1 m/s) + 0.25 m = 0.65 m

This is an approximation for the worst case.

When using small data carriers and/or small read heads, the distance is reduced considerably!

BIS L-405 Installation

Installation BIS L-405, permissible distances

Distance from data carrier to data carrier

| | BIS L-200-03/L | BIS L-201-03/L | BIS L-202-03/L |
|---------------|----------------|----------------|----------------|
| BIS L-405-033 | > 25 cm | > 30 cm | > 40 cm |
| | BIS L-100-05/L | BIS L-101-05/L | BIS L-102-05/L |
| BIS L-405-037 | > 25 cm | > 30 cm | > 40 cm |

Distance from read head to read head

The following distances must be maintained between the individual BIS L-405 systems:

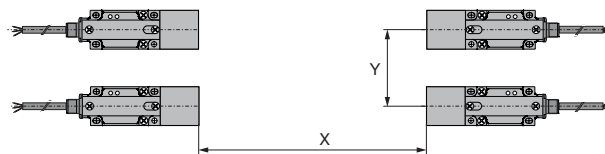

| | Distance X | Distance Y |
|----------------------|------------|------------|
| BIS L-405...-001-... | 1 m | 1 m |
| BIS L-405...-002-... | 0.5 m | 0.3 m |
| BIS L-405...-003-... | 0.5 m | 0.3 m |
| BIS L-405...-004-... | 0.5 m | 0.3 m |

BIS L-405-...-001-... Installation

Clear zone and distances

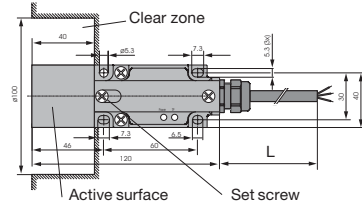

Specifications by data carrier BIS L-405-033-001-...

| Specifications by data carrier (installed in clear zone) | For v = 0 (static condition) | | | | |
|--|------------------------------|--|------|------|------|
| | Read distance (mm) | Offset to center axis at distance of: (mm) | | | |
| | | 0-25 | 0-35 | 0-45 | 0-15 |
| BIS L-200-03 | 0 - 30 | ± 15 | - | - | - |
| BIS L-201-03 | 0 - 40 | - | ± 20 | - | - |
| BIS L-202-03 | 0 - 55 | - | - | ± 30 | - |
| BIS L-203-03 | 0 - 20 | - | - | - | ± 10 |

Speeds:

| | At read distance [mm] | Speed [m/s] |
|--------------|-----------------------|-------------|
| BIS L-200-03 | 15 | 0.4 |
| BIS L-201-03 | 20 | 0.45 |
| BIS L-202-03 | 27.5 | 0.5 |
| BIS L-203-03 | 10 | 0.28 |

Specifications by data carrier BIS L-405-037-001-...

| Specifications used with data carrier (installed in clear zone) | For v = 0 (static mode) | | | | |
|---|-------------------------|--|------|------|------|
| | Read distance (mm) | Offset to center axis at distance of: (mm) | | | |
| | | 0-25 | 0-35 | 0-45 | 0-15 |
| BIS L-100-05 | 0 - 30 | ± 15 | - | - | - |
| BIS L-101-05 | 0 - 40 | - | ± 20 | - | - |
| BIS L-102-05 | 0 - 55 | - | - | ± 30 | - |
| BIS L-103-05 | 0 - 20 | - | - | - | ± 10 |

| | At read distance [mm] | Speed [m/s] |
|--------------|-----------------------|-------------|
| BIS L-100-05 | 15 | 0.45 |
| BIS L-101-05 | 20 | 0.5 |
| BIS L-102-05 | 27.5 | 0.72 |
| BIS L-103-05 | 10 | 0.36 |

BIS L-405-...-002-... Installation

Installation BIS L-405-...-002-...

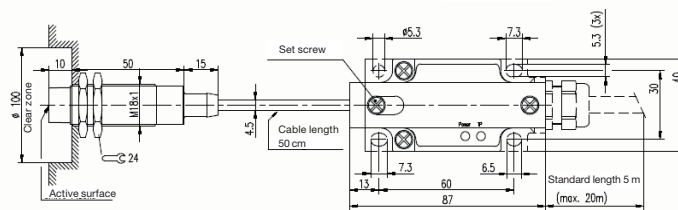

Specifications by data carrier BIS L-405-033-002-...

| Specifications by data carrier (installed in clear zone) | For v = 0 (static condition) | | | | |
|--|------------------------------|--|------|------|------|
| | Read distance (mm) | Offset to center axis at distance of: (mm) | | | |
| | | 0-10 | 0-15 | 0-20 | 0-25 |
| BIS L-200-03 | 0 - 23 | ± 12 | ± 12 | ± 8 | - |
| BIS L-201-03 | 0 - 27 | ± 15 | ± 15 | ± 15 | ± 6 |
| BIS L-203-03 | 0 - 16 | ± 8 | ± 4 | - | - |

Speeds:

| | At read distance [mm] | Speed [m/s] |
|--------------|-----------------------|-------------|
| BIS L-200-03 | 11.5 | 0.18 |
| BIS L-201-03 | 13.5 | 0.22 |
| BIS L-203-03 | 8 | 0.15 |

Specifications by data carrier BIS L-405-037-002-...

| Specifications by data carrier (installed in clear zone) | For v = 0 (static condition) | | | | |
|--|------------------------------|--|------|------|------|
| | Read distance (mm) | Offset to center axis at distance of: (mm) | | | |
| | | 0-10 | 0-15 | 0-20 | 0-25 |
| BIS L-100-05 | 0 - 23 | ± 12 | ± 12 | ± 8 | - |
| BIS L-101-05 | 0 - 27 | ± 15 | ± 15 | ± 15 | ± 6 |
| BIS L-103-05 | 0 - 16 | ± 8 | ± 4 | - | - |

| | At read distance [mm] | Speed [m/s] |
|--------------|-----------------------|-------------|
| BIS L-100-05 | 11.5 | 0.22 |
| BIS L-101-05 | 13.5 | 0.3 |
| BIS L-103-05 | 8 | 0.18 |

BIS L-405-...-003-... Installation

Installation
BIS L-405-...-003-...

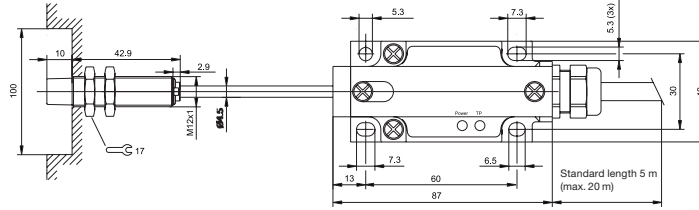

Specifications by data carrier
BIS L-405-033-003-...

| Specifications by data carrier (installed in clear zone) | For v = 0 (static condition) | | | | |
|--|------------------------------|--|-----|------|--|
| | Read distance (mm) | Offset to center axis at distance of: (mm) | | | |
| | | 0-5 | 0-8 | 0-11 | |
| BIS L-203-03 | 0 - 11 | ± 6 | ± 4 | ± 2 | |

Speeds:

| | At read distance [mm] | Speed [m/s] |
|--------------|-----------------------|-------------|
| BIS L-203-03 | 51.5 | 0.11 |

Specifications by data carrier
BIS L-405-037-003-...

| Specifications by data carrier (installed in clear zone) | For v = 0 (static condition) | | | | |
|--|------------------------------|--|-----|------|--|
| | Read distance (mm) | Offset to center axis at distance of: (mm) | | | |
| | | 0-5 | 0-8 | 0-11 | |
| BIS L-103-05 | 0 - 11 | ± 6 | ± 4 | ± 2 | |

| | At read distance [mm] | Speed [m/s] |
|--------------|-----------------------|-------------|
| BIS L-103-05 | 5.5 | 0.14 |

BIS L-405-...-004-... Installation

Installation
BIS L-405-...-004-...

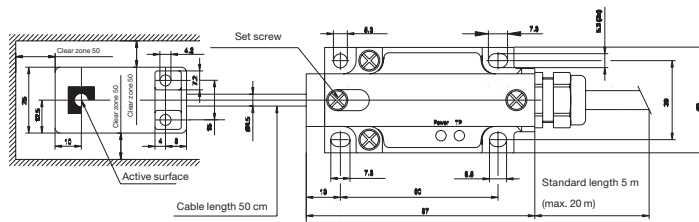

Specifications by data carrier
BIS L-405-033-004-...

| Specifications by data carrier (installed in clear zone) | For v = 0 (static condition) | | | | | |
|--|------------------------------|--|------|------|------|--|
| | Read distance (mm) | Offset to center axis at distance of: (mm) | | | | |
| | | 0-10 | 0-15 | 0-20 | 0-25 | |
| BIS L-200-03 | 0 - 23 | ± 12 | ± 12 | ± 8 | - | |
| BIS L-201-03 | 0 - 27 | ± 15 | ± 15 | ± 15 | ± 6 | |
| BIS L-203-03 | 0 - 16 | ± 8 | ± 4 | - | - | |

Speeds:

| | At read distance [mm] | Speed [m/s] |
|--------------|-----------------------|-------------|
| BIS L-200-03 | 11.5 | 0.18 |
| BIS L-201-03 | 13.5 | 0.22 |
| BIS L-203-03 | 8 | 0.15 |

Specifications by data carrier
BIS L-405-037-004-...

| Specifications by data carrier (installed in clear zone) | For v = 0 (static condition) | | | | | |
|--|------------------------------|--|------|------|------|--|
| | Read distance (mm) | Offset to center axis at distance of: (mm) | | | | |
| | | 0-10 | 0-15 | 0-20 | 0-25 | |
| BIS L-100-05 | 0 - 23 | ± 12 | ± 12 | ± 8 | - | |
| BIS L-101-05 | 0 - 27 | ± 15 | ± 15 | ± 15 | ± 6 | |
| BIS L-103-05 | 0 - 16 | ± 8 | ± 4 | - | - | |

| | At read distance [mm] | Speed [m/s] |
|--------------|-----------------------|-------------|
| BIS L-100-05 | 11.5 | 0.22 |
| BIS L-101-05 | 13.5 | 0.3 |
| BIS L-103-05 | 8 | 0.18 |

BIS L-405 Installation

Lead assignments BIS L-503-...

| Connection for | Description | Color |
|----------------|-------------|--------------|
| SUPPLY VOLTAGE | +24 V DC | RED |
| | 0 V DC | BLUE |
| OUTPUTS | Bit 0 | WHITE |
| | Bit 1 | BROWN |
| | Bit 2 | GREEN |
| | Bit 3 | YELLOW |
| | Bit 4 | GRAY |
| | Bit 5 | ROSE |
| | Bit 6 | BLACK |
| | Bit 7 | VIOLET |
| | TP | WHITE/GREEN |
| | STR | BROWN/GREEN |
| INPUTS | 0V | WHITE/YELLOW |
| | ReStart | GRAY/ROSE |
| | ADR | RED/BLUE |
| SHIELDING | SHIELD | - |
| n/c | - | YELLOW/BROWN |



BIS L-405 Installation

Installing the BIS L-405 Processor

When installing BIS L-405 and BIS L-503, remove the PG fitting. Insert BIS L-503 plug into the correct sockets of the BIS L-405. Tighten screws and PG fitting.



Remove PG fitting before opening BIS L-405 and BIS L-503.

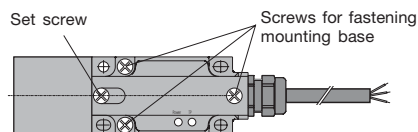
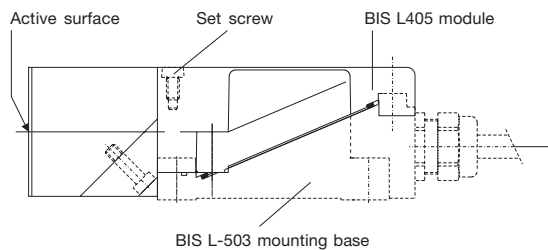

BIS L-405 Reorienting and Rotating the Read Head

- Reorienting the read head**
- Remove the two screws on the read head base
 - Turn the read head module 180°
 - Tighten both screws

- Rotating the read head**
- Unscrew the set screw
 - Read head module can be rotated stepless (complete with read head base) to the desired position (range: 270°)
 - Tighten set screw
 - Read head module is secured against over-rotation



Read head modules are not interchangeable!

Active surface positions

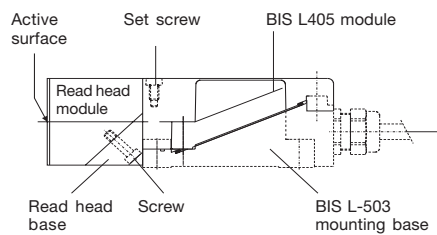
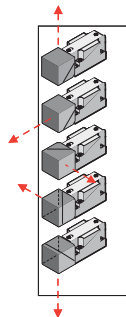

BIS L-405 Connection Diagrams

Wiring the inputs

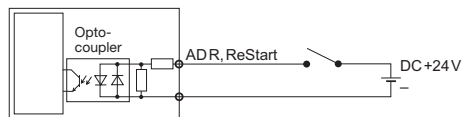

Supply voltage: DC 24 V +10% / -20% (incl. ripple)
 Input high: min. 17 V, typ. 3 mA
 Input low: max. 6 V, ≤ 1.5 mA

Wiring the outputs for data

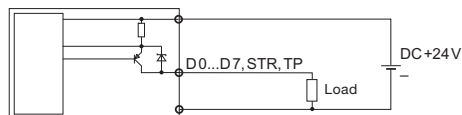

Supply voltage: DC 24 V +10% / -20% (incl. ripple)
 Output current: max. 50 mA
 Voltage drop at 50 mA: ≤ 1.5 V

BIS L-405 Technical Data

| | | |
|-------------------------------|--|---|
| General data | Housing | Plastic (PBT) |
| Temperature range | Ambient temperature | 0 °C to +60 °C |
| Enclosure rating | Enclosure rating | IP 67 (only when assembled) |
| Supply voltage | Supply voltage Current consumption Output current per output | DC 24 V +10 % / -20 % (incl. ripple) ≤ 50 mA with no load max. 50 mA |
| LED function indicator | Power Tag Present Overflow | LED green LED yellow LED yellow flashing (The "Tag Present" LED flashes rapidly if the data from a data carrier were not completely read and a new data carrier has arrived in the active zone.) |

CE The CE Marking verifies that our products conform to the requirements of the EU Directive 2004/108/EC (EMC Directive) and the EMC Law. In our EMC Laboratory, which is accredited by the DATech for Testing Electromagnetic Compatibility, we have verified that Balluff products meet the EMC requirements of the following Generic Standards: EN 61000-6-4 (Emission), EN 61000-6-2 (Noise Immunity).

BIS L-405 Ordering Information

Part Numbers

BIS L-405-03_-00_-05-MU

- Balluff Identification System _____
 - Series L _____
 - Hardware-Type _____
405 = Plastic housing
 - Software-Type _____
033 = 8 bits parallel
037 = 8 bits parallel with CRC_16 data check
 - Hardware version _____
001 = Coil Ø 34 mm
002 = discharged read head modules M18 (0.5 m cable)
003 = discharged read head modules M12 (0.5 m cable)
004 = discharged read head modules C-305 housing (0.5 m cable)
 - Interface _____
05 = parallel
 - Module _____
MU = Module unit
- Used only together with mounting base BIS L-503-PU1-...



Read head modules are not interchangeable!

Appendix, ASCII Table

| Deci- mal | Hex | Control Code | ASCII | Deci- mal | Hex | Control Code | ASCII | Deci- mal | Hex | ASCII | Deci- mal | Hex | ASCII | Deci- mal | Hex | ASCII | Deci- mal | Hex | ASCII |
|--------------|-----|-----------------|-------|--------------|-----|-----------------|-------|--------------|-----|-------|--------------|-----|-------|--------------|-----|-------|--------------|-----|-------|
| 0 | 00 | Ctrl @ | NUL | 22 | 16 | Ctrl V | SYN | 44 | 2C | , | 65 | 41 | A | 86 | 56 | V | 107 | 6B | k |
| 1 | 01 | Ctrl A | SOH | 23 | 17 | Ctrl W | ETB | 45 | 2D | - | 66 | 42 | B | 87 | 57 | W | 108 | 6C | l |
| 2 | 02 | Ctrl B | STX | 24 | 18 | Ctrl X | CAN | 46 | 2E | . | 67 | 43 | C | 88 | 58 | X | 109 | 6D | m |
| 3 | 03 | Ctrl C | ETX | 25 | 19 | Ctrl Y | EM | 47 | 2F | / | 68 | 44 | D | 89 | 59 | Y | 110 | 6E | n |
| 4 | 04 | Ctrl D | EOT | 26 | 1A | Ctrl Z | SUB | 48 | 30 | 0 | 69 | 45 | E | 90 | 5A | Z | 111 | 6F | o |
| 5 | 05 | Ctrl E | ENQ | 27 | 1B | Ctrl [| ESC | 49 | 31 | 1 | 70 | 46 | F | 91 | 5B | [| 112 | 70 | p |
| 6 | 06 | Ctrl F | ACK | 28 | 1C | Ctrl \ | FS | 50 | 32 | 2 | 71 | 47 | G | 92 | 5C | \ | 113 | 71 | q |
| 7 | 07 | Ctrl G | BEL | 29 | 1D | Ctrl] | GS | 51 | 33 | 3 | 72 | 48 | H | 93 | 5D |] | 114 | 72 | r |
| 8 | 08 | Ctrl H | BS | 30 | 1E | Ctrl ^ | RS | 52 | 34 | 4 | 73 | 49 | I | 94 | 5E | ^ | 115 | 73 | s |
| 9 | 09 | Ctrl I | HT | 31 | 1F | Ctrl _ | US | 53 | 35 | 5 | 74 | 4A | J | 95 | 5F | _ | 116 | 74 | t |
| 10 | 0A | Ctrl J | LF | 32 | 20 | | SP | 54 | 36 | 6 | 75 | 4B | K | 96 | 60 | ` | 117 | 75 | u |
| 11 | 0B | Ctrl K | VT | 33 | 21 | | ! | 55 | 37 | 7 | 76 | 4C | L | 97 | 61 | a | 118 | 76 | v |
| 12 | 0C | Ctrl L | FF | 34 | 22 | | " | 56 | 38 | 8 | 77 | 4D | M | 98 | 62 | b | 119 | 77 | w |
| 13 | 0D | Ctrl M | CR | 35 | 23 | | # | 57 | 39 | 9 | 78 | 4E | N | 99 | 63 | c | 120 | 78 | x |
| 14 | 0E | Ctrl N | SO | 36 | 24 | | \$ | 58 | 3A | : | 79 | 4F | O | 100 | 64 | d | 121 | 79 | y |
| 15 | 0F | Ctrl O | SI | 37 | 25 | | % | 59 | 3B | ; | 80 | 50 | P | 101 | 65 | e | 122 | 7A | z |
| 16 | 10 | Ctrl P | DLE | 38 | 26 | | & | 60 | 3C | < | 81 | 51 | Q | 102 | 66 | f | 123 | 7B | { |
| 17 | 11 | Ctrl Q | DC1 | 39 | 27 | | ' | 61 | 3D | = | 82 | 52 | R | 103 | 67 | g | 124 | 7C | |
| 18 | 12 | Ctrl R | DC2 | 40 | 28 | | (| 62 | 3E | > | 83 | 53 | S | 104 | 68 | h | 125 | 7D | } |
| 19 | 13 | Ctrl S | DC3 | 41 | 29 | |) | 63 | 3F | ? | 84 | 54 | T | 105 | 69 | i | 126 | 7E | ~ |
| 20 | 14 | Ctrl T | DC4 | 42 | 2A | | * | 64 | 40 | @ | 85 | 55 | U | 106 | 6A | j | 127 | 7F | DEL |
| 21 | 15 | Ctrl U | NAK | 43 | 2B | | + | | | | | | | | | | | | |