

OPERATOR'S MANUAL

**LRP75 Long Range
Passive
Reader/Writer**

Manual Revision 5, 9-02
Publication # 17-1289



Escort Memory Systems Warranty

Escort Memory Systems warrants that all products of its own manufacture conform to Escort Memory Systems specifications and are free from defects in material and workmanship when used under normal operating conditions and within the service conditions for which they were furnished. The obligation of Escort Memory Systems hereunder shall expire one (1) year after delivery, unless otherwise specified, and is limited to repairing, or at its option, replacing without charge, any such product which in Escort Memory System's sole opinion proves to be defective within the scope of this Warranty. In the event Escort Memory Systems is not able to repair or replace defective products or components within a reasonable time after receipt thereof, Buyers shall be credited for their value at the original purchase price. Escort Memory Systems must be notified in writing of the defect or nonconformity within the warranty period and the affected product returned to Escort Memory Systems factory or to an authorized service center within thirty (30) days after discovery of such defect or nonconformity. Shipment shall not be made without prior authorization by Escort Memory Systems.

This is Escort Memory Systems' sole warranty with respect to the products delivered hereunder. No statement, representation, agreement or understanding oral or written, made by an agent, distributor, representative, or employee of Escort Memory Systems which is not contained in this warranty, will be binding upon Escort Memory Systems, unless made in writing and executed by an authorized Escort Memory Systems employee. Escort Memory Systems makes no other warranty of any kind whatsoever, expressed or implied, and all implied warranties of merchantability and fitness for a particular use which exceed the aforesaid obligation are hereby disclaimed by Escort Memory Systems and excluded from this agreement. Under no circumstances shall Escort Memory Systems be liable to Buyer, in contract or in tort, for any special, indirect, incidental, or consequential damages, expenses, losses or delay however caused.

Equipment or parts which have been subject to abuse, misuse, accident, alteration, neglect, unauthorized repair or installation are not covered by warranty. Escort Memory Systems shall make the final determination as to the existence and cause of any alleged defect. No liability is assumed for expendable items such as lamps and fuses. No warranty is made with respect to custom equipment or products produced to Buyer's specifications except as specifically stated in writing by Escort Memory Systems in the contract for such custom equipment.

This warranty is the only warranty made by Escort Memory Systems with respect to the goods delivered hereunder, and may be modified or amended only by a written instrument signed by a duly authorized officer of Escort Memory Systems and accepted by the Buyer.

Extended warranties of up to four years are available for purchase for most EMS products. Contact EMS or your distributor for more information.

This document contains proprietary information which is protected by copyright. All rights are reserved. The information in this manual has been carefully checked and is believed to be accurate; however, no responsibility is assumed for possible inaccuracies or omissions. Specifications are subject to change without notice.

EMS®, Escort Memory Systems™ and the EMS © logo are registered trademarks of Escort Memory Systems, a Datalogic Group Company. Other brand and product names mentioned are trademarks or registered trademarks of their respective holders.

Escort Memory Systems
A Datalogic Group Company

170 Technology Circle
Scotts Valley, CA 95066
Telephone (831) 438-7000
FAX (831) 438-5768

www.ems-rfid.com
email: info@ems-rfid.com



Chapter 1 Getting Started

1.1	Introduction	1
1.2	Unpacking and Inspection	1
1.3	FCC Compliance	2
1.4	Changes and Modifications	2

Chapter 2 Mechanical Specifications

2.1	Dimensions	3
2.2	Mounting Options	3
2.3	RF Range and Orientation	4
2.4	Locating the LRP75	4
2.4.1	Guidelines	5

Chapter 3 Power and Electrical Interface

3.1	Internal Junction Blocks	7
3.2	Power	7
3.2.1	Requirement	7
3.2.2	Connections	8
3.3	Serial Communications	8
3.4	RS232/RS422 Interface	8
3.5	Serial Connections	9
3.5.1	RS232 and Power Cable	10
3.5.2	Wiring	10
3.6	LED Indicator	11

Chapter 4 Configuration Menu

4.1	Introduction	13
4.1.1	Using the EC Program	13
4.2	Configuration Menu	13
4.2.1	Set COM1 Parameters	14
4.2.2	Set Operating Mode	14
4.2.3	Download Software Updates	16

Chapter 5 Standard RFID Interface

5.1	Introduction	17
5.2	Command Timeout Values	17
5.3	Address Blocks	18
5.4	ABx Error Codes	19
5.4.1	ABx Standard Error Format	20
5.5	Command Descriptions	20
5.6	ABx Standard Commands	20
5.6.1	Command 4 (04 Hex): Tag Fill	20
5.6.2	Command 5 (05 Hex): Block Read	22
5.6.3	Command 6 (06 Hex): Block Write	24
5.6.4	Command 7 (07H): Read Tag Serial Number	25
5.6.5	Command 8 (08 Hex): Tag Search	26

Table of Contents

5.6.6	Command D (0D Hex): Start/Stop Continuous Block Read	27
5.6.7	Command E (0EH) Read SN and Data	30
5.6.8	Command F (0FH) Start/Stop Continuous Read SN and Data	31
5.7	ABx Fast Commands	33
5.7.1	ABx Command Packet Structure	33
5.7.2	Command 4 (04 Hex): Tag Fill	35
5.7.3	Command 5 (05 Hex): Block Read	38
5.7.4	Command 6 (06 Hex): Block Write	40
5.7.5	Command 7 (07H): Read Tag Serial Number	42
5.7.6	Command 8 (08 Hex): Tag Search	44
5.7.7	Command D (0D Hex): Start/Stop Continuous Block Read	45
5.7.8	Command E (0EH) Read SN and Data	49
5.7.9	Command F (0FH) Start/Stop Continuous Read SN and Data	51

Appendix A Technical Specifications

A.1	Electrical Characteristics	55
A.2	Physical Characteristics	55
A.3	Environmental	55
A.4	Communication Characteristics	55

Appendix B LRP75 Beta Connections

B.1	Internal Junction Blocks	57
B.2	Power Connections	57
B.3	Serial Connections	58

Appendix C Models and Accessories..... 59

Appendix D ASCII Chart..... 61



1.1 Introduction

Escort Memory Systems' passive read/write system is a complete family of field-proven read/write Radio-Frequency Identification products.

The system consists of RFID tags, reader/writers, antennas, controllers, bus interfaces, and ancillary equipment. Tags can be attached to a product or its carrier and act as an electronic identifier, job sheet, portable database, or manifest. Tags are read and updated via an Escort Memory Systems Reader/Writer, through any non-conducting material, while moving or standing still.

Escort Memory Systems' LRP-Series long range passive RFID system is the latest in our line of high performance, industrial RFID equipment. The passive design of the LRP read/write system uses the RF field from the antenna to power the tag, eliminating the need for tag batteries. The LRP passive read/write system is designed to provide cost effective RFID data collection and control solutions to automation and material handling applications.

The LRP system uses the internationally recognized ISM frequency of 13.56 MHZ to both power the tag, and to establish a radio link to transfer the information. LRP-Series passive tags provide 48 bytes of reprogrammable memory.

The LRP75 is encased in a NEMA2 enclosure. The LRP75 is equipped with an internal antenna that has a range of 4 inches.

The LRP75 has one serial port that supports RS232 or RS422 serial communications. The serial port is used to receive commands and software from the host and to send the data back.

1.2 Unpacking and Inspection

When you unpack the LRP75, retain the original shipping carton and packing material in case any item has to be returned to Escort Memory Systems. Inspect each item carefully for evidence of damage. If any item appears to be damaged, notify your Escort Memory Systems representative immediately.

The following is supplied with the LRP75:

- 1 LRP75
- 2 Short screws
- 2 Long screws
- 2 Threaded inserts

The following components are required for configuring a complete system:

- LRP-Series Passive Read/Write Tags
- LRP75-to-host cable (user-supplied)
- RS232/RS422 host
- 24 Vdc +/- 10%, 5 W power supply

1.3 FCC Compliance

This equipment has been tested and found to comply with the limits for a Class B digital device, pursuant to Part 15 of the FCC Rules. These limits are designed to provide reasonable protection against harmful interference in a residential installation. This equipment generates, uses and can radiate radio frequency energy and, if not installed and used in accordance with the instructions, may cause harmful interference to radio communications. However, there is no guarantee that interference will not occur in a particular installation. If this equipment does cause harmful interference to radio or television reception, which can be determined by turning the equipment off and on, the user is encouraged to try to correct the interference by one or more of the following measures:

- Reorient or relocate the receiving antenna.
- Increase the separation between the equipment and receiver.
- Connect the equipment into an outlet on a circuit different from that to which the receiver is connected.
- Consult the dealer or an experienced radio/TV technician for help.

1.4 Changes and Modifications

Any changes or modifications to the LRP75 not expressly approved by Escort Memory Systems, could void the user's authority to operate the equipment.



Mechanical Specifications

2.1 Dimensions

Figure 2-1 shows the dimensions and mounting hole locations for the LRP75 Reader/Writer.

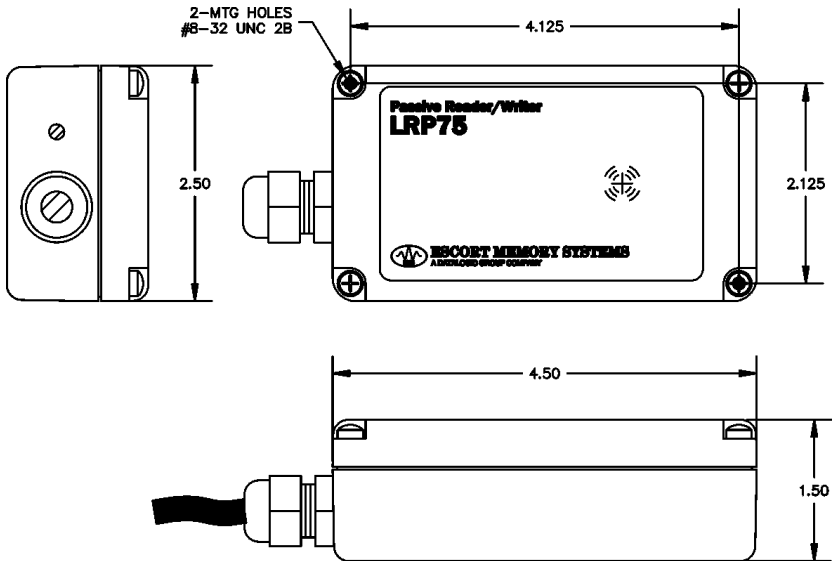

Figure 2-1. LRP75 dimensions and mounting hole locations

2.2 Mounting Options

The LRP75 ships with mounting screws and threaded inserts to provide mounting options. The LRP75 can be through-bolted with the two longer screws or mounted with an adhesive backing such as Velcro.[®]

If you do not use the long screws to through-bolt the LRP75, you should install the threaded inserts and use the short screws to secure the lid.

To install the threaded inserts:

1. Place the LRP75 upside down on a firm surface.
2. Place the threaded inserts, smooth end first, into the two holes and press in firmly.
3. From the lid side of the LRP75, insert the screws and tighten them until the inserts are flush with the bottom of LRP75.

2.3 RF Range and Orientation

The following information should be considered when positioning the LRP75. The path of the tags through the RF field should be within the guaranteed reading/writing range unless sufficient site testing has been performed to assure consistent RF communications.

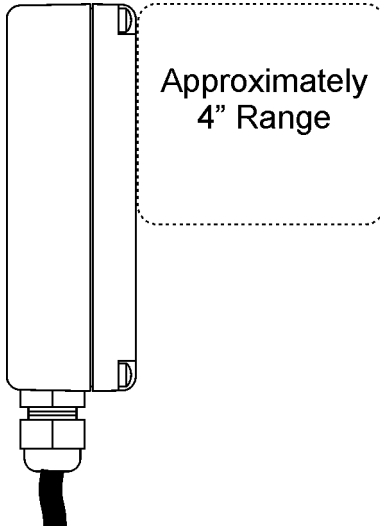

Figure 2-2. LRP75 reading range

2.4 Locating the LRP75

The reading range of the LRP75 is primarily affected by two environmental variables. The first, and most influential of these variables, is the presence of metal or any other electrically conductive material within the range of the antenna. The reader can be safely mounted to a metal surface without compromising the reading range; however, any conductive material within the area in front of and to the sides of the reader - anywhere a tag can be read - will affect the reading range to some extent. The most reliable method for determining the effects of metal on the reading range is to perform site tests.

Electromagnetic radiation is the second environmental variable that affects the reading range and overall performance of the LRP75. The reader should not be located close to any sources of electromagnetic radiation. Do not mount a LRP75 closer than two meters from another LRP75, and a greater distance from longer-range readers, such as the EMS LRP820. Again, site testing will provide the most reliable means to determine the read range in a given environment.

2.4.1 Guidelines

- Isolate the LRP75 from electromagnetic radiation.
- Avoid surrounding the LRP75 with metal.
- Maintain at least two meters spacing between adjacent LRP75s.
- Stay within the guaranteed range of the tag you are using.
- Conform with EIA RS232 and RS422 standards.

This page left blank intentionally.



Power and Electrical Interface

3.1 Internal Junction Blocks

The LRP75 is connected to external power and communications cabling through an internal terminal strip. The power and serial communication junction block (J1) has 10 terminals and accepts AWG 22-14 wires.

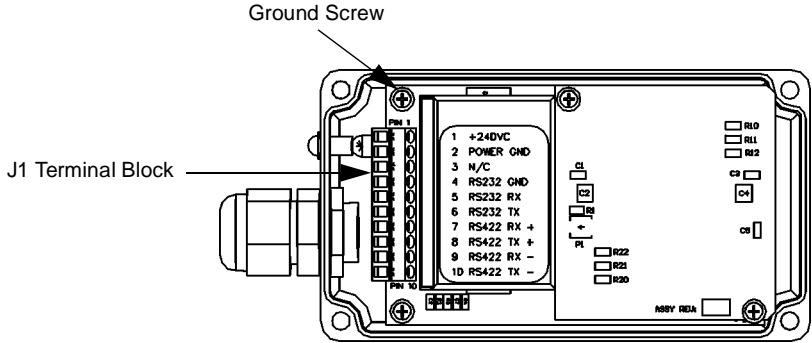

Figure 3-1. Internal junction block

NOTE: Earlier models of the LRP75 have different power and serial communications connections. For more information, see Appendix B, *LRP75 Beta Connections*.

3.2 Power

3.2.1 Requirement

The LRP75 power supply requirements are:

- 24 Vdc +/- 10%
- 5 Watts maximum consumption

The maximum current consumption at 24 Vdc is 200 mA.

3.2.2 Connections

Connection to DC power is through pins 1 and 2 of the internal terminal block J1.

Table 3-1: J1 Power Connections

Terminal	Description
1	+24 Vdc
2	Power Ground

3.3 Serial Communications

The LRP75 offers either RS232 or RS422 communications. The RS422 option provides the superior reliability over longer distances or in noisy environments. Communication parameters, such as baud rate, are set by the configuration program.

CAUTION: Do not bundle communications wiring with high current power lines. This will cause communications errors.

3.4 RS232/RS422 Interface

The LRP75 is set to automatically enter run mode seven seconds after power-on the device. This allows you to enter the configuration program by entering a <control D> after power-on. If no commands are received by the reader/writer during the seven seconds, the LRP75 enter run mode with existing operating parameters. For more information on the Configuration Menu refer to Chapter 4.

To communicate with the device via RS232, set the serial communications parameters of the host as follows:

Baud rate	9600
Parity	none
Data bits	8
Stop bit	1

NOTE: The LRP75 automatically resets to 9600, N, 8,1 for seven seconds whenever the power is cycled, after which it will apply the setting made in the configuration menu.

3.5 Serial Connections

The LRP75 can be wired to communicate with the host either through an RS232 or RS422 interface. Connection to the serial interface is through the J1 terminal shown in Figure 3-1 on page 7.

Table 3-2 gives the pinouts for the J1 terminal block.

Table 3-2: J1 Serial Communications Pinouts

Terminal	Function
3	Reserved, no connection
4	Signal Ground (DB9, pin 5)
5	RS232 RX (wired to host DB9, pin 3)
6	RS232 TX (wired to host DB9, pin 2)
7	RS422 RX +
8	RS422 TX +
9	RS422 RX -
10	RS422 TX -

NOTE: In order to configure the unit for RS422, you must first establish communications through RS232 and update the communication parameters.

The signals and electrical loads should conform to the electrical specifications of EIA Standard for RS232 or RS422. The maximum cable length specified for RS232 is 50 feet. Use the RS422 interface for longer communications links. Use high quality shielded cable for these connections.

3.5.1 RS232 and Power Cable

Figure 3-2 shows how to construct a demonstration cable with power and RS232 serial communications to a PC host with a DE9 serial port connector.

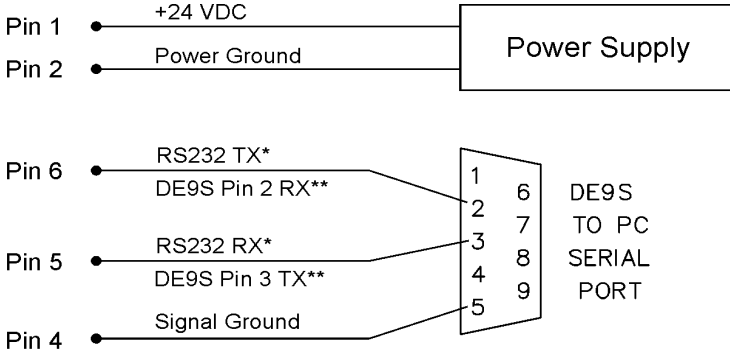

* Signal names relative to the LRP75

** Signal names relative to a PC 9-pin serial connector

Figure 3-2. LRP75 to PC host demo

3.5.2 Wiring

Use shielded cable only. Connect shield drain of the power and data cabling to either ground on the J1 connector (terminal 2 or 4).

- Recommended cable for RS422 is Belden 3107A, 3108A or compatible.
- Recommended cable for RS232 is Belden 9941 or compatible.

To fully comply with FCC and CE Regulations, wind the power and data cabling around a type 43 ferrite toroid such as Fairrite™ part number 2643803802 or Amidon™ part number FT-240-43. Install the toroid as close as possible to the LRP75's gland nut. You must connect the internal ground screw, shown in Figure 3-1 on page 7, to the nearest earth ground outside the unit.

To make the ground connection, first terminate a length of 1/8-inch copper braid with a ring terminal such as Panduit™ part number P18-45. Fasten the ring terminal to the ground screw. For a tight seal, chase the braid through the gland nut against the data and power cabling.

To connect your cable to the LRP75:

1. Remove the cover of the antenna by loosening the four captive screws.
2. Loosen the cord grip, feed the cable through the cord grip and attach the wires to the terminal screws. Tighten the cord grip to seal the cable. Use a cable of sufficient diameter to properly seal with the cord grip. The recommended minimum O.D. is .125 inches (3.2 mm).

NOTE: Due to the small size of the LRP75 enclosure and gland nut, you may have difficulty sealing wires passing through the gland nut. Olflex[®] cable part number 911285 is readily available and will satisfy the requirements of most applications.

3. Re-assemble the enclosure and secure the screws.

3.6 LED Indicator

The LRP75 has one bi-color LED indicating power on and activity on the serial port. Table 3-3 shows the LED activity and meaning.

Table 3-3: LRP75 LED Indicator

LED Action	LRP75 state	Description
Slow RED Blink	Power-up or reset	The LED will flash RED slowly for about seven seconds following power-up during which time the user may send a <Ctrl> D to enter configuration mode.
Fast RED Blink	Configuration mode	If the LRP75 receives a <Ctrl> D during the initial seven second period, the LED will flash at a faster rate until configuration mode has been exited.
Steady GREEN	Idle	The unit is ready for an ABx command. A steady GREEN LED indicates that the seven second period has elapsed without entering configuration mode, or configuration has been completed.
GREEN Blink	LRP75 upgrade	While downloading a new, or custom, program to the LRP75, the LED will blink GREEN.
Short RED/ GREEN Blink	Executing Command	While the reader/writer is occupied with a command, the LED will be flashing GREEN to RED. A RED to GREEN flash indicates a tag is being searched for, and the command is being executed.

Table 3-3: LRP75 LED Indicator

LED Action	LRP75 state	Description
RED and GREEN	Executing Continuous Block Read	The LED will be both RED and GREEN (orange) indicates the LRP75 is in continuous mode. There is short RED flash when data sent to the host. ¹

1. When Software Handshaking is enabled, and the host has sent the LRP75 an XOFF, the RED LED will be on while the LRP75 transmit buffer fills. The LED will remain RED until an XON is received and the LRP buffer is emptied.



4.1 Introduction

The LRP75 contains a configuration program in EEPROM memory for defining the data format and serial protocol. After the LRP75 has been powered, it pauses for seven seconds waiting for the command to enter the configuration program. The communication parameters during this seven second period are:

- 9600 baud
- 8 data bits
- No parity
- 1 stop bit

Use a terminal emulation program (such as EC or HyperTerminal) to send a <control D> within this seven second period to initialize the Configuration Menu. If the LRP75 does not receive a <control D>, it will go "online" with the existing user-defined settings.

4.1.1 Using the EC Program

The terminal emulation program, EC.EXE, is recommended for LRP75/Host communications. It can be downloaded from Escort Memory Systems Web site (www.ems-rfid.com). Unlike many other terminal emulation programs, EC.EXE can transfer binary data in ASCII hex-based format, as required by the LRP75 commands. The .HEX file downloads to the LRP are in Intel Hex format.

4.2 Configuration Menu

The Configuration Menu will display the current state of the operating parameters. To change a parameter, enter the decimal number shown in the menu for the option you want. An invalid entry will return you to the Main Menu.

The Main Board Configuration menu displays the current main board software version number together with the RFID firmware version.

```
***** LRP75/76 Standard Program V1.3E *****  
RF module:4.01J  
Serial Port COM1:RS232, 9600, N, 8, 1 No Handshake  
Operating Mode:ABx Standard  
Tag Type: Phillips I-CODE 1
```

- [1] Set COM1 Parameters
- [2] Set Operating Mode
- [3] Set Tag Type
- [4] Restore Factory Defaults
- [5] Download New Program
- [6] Download RFID Firmware
- [7] Exit to Operating Mode

Enter Selection:

4.2.1 Set COM1 Parameters

The Set COM1 Parameters menu is given below.

```
*** Set COM1 Parameters **  
  
Operating mode? [0] RS232 [1] RS422  
Baud Rate? [0] 1200 [1] 2400 [2] 4800 [3] 9600 [4] 19200  
Data size? [0] 7bit [1] 8bit  
Parity? [0] None [1] Even [2] Odd  
Handshake [0] None [1] Xon/Xoff  
  
Save Changes to EEPROM? [0] No [1] Yes
```

Enter the number corresponding to the parameter you wish to enable.

4.2.2 Set Operating Mode

The Set Operating Mode menu is given below.

```
*** Set Operating Mode ***  
Commands Protocol? [0] ABx Standard [1] ABx Fast  
Checksum? [0] Disabled [1] Enabled  
Power up performing Continuous Read?  
[0] NO  
[1] Continuous Block Read (0DH) active  
[2] Continuous Read SN and Data (0FH) active  
-> 1  
Start Address (0 to 47) 0  
Length (1 to 48) 48  
Delay Between Duplicate Decodes (0 to 60) 1  
Raw Read Response? [0] NO [1] CR terminate [2] CR/LF  
terminate 2  
Save Changes to EEPROM? [0] No [1] Yes
```

The LRP75 supports ABx Standard and ABx Fast RFID command protocols. Select your command protocol from this menu. If you select ABx fast, you can select an optional checksum. For data delivery verification to the host, it is recommended to have the checksum enabled.

You can also select from three Run Mode types. The options are:

[0] NO

LRP75 will wait for an ABx command after reset. If you choose 0 (NO), then the LRP75 configuration is complete and you are given the option to save the settings.

[1] Continuous Block Read (0DH) active

After reset, the LRP75 will be in Continuous Block Read Mode just as if you had issued a Continuous Block Read (0DH) to the LRP75. You must enter the tag start address, read length, and the delay between identical decodes values.

[2] Continuous Read SN and Data (0FH) active

After reset, the LRP75 will be performing Continuous Read SN Data. This is the same as if the 0FH command had been issued to the LRP75. You must enter the tag start address, read length, and the delay between identical decodes values.

Raw Read Response

It is possible to set the LRP75 to only send raw tag data to the host. The raw read data does not contain a header, length, command number, or terminator. If the data on the tag is all printable ASCII, then the entire packet can be printed on any terminal emulator or EC.

To receive a raw read response, the LRP75 must be set to use ABx Fast, and to start in Continuous Block Read Run Mode.

Raw Read Response? [0] NO [1] CR terminate [2] CR/LF terminate

If you choose the raw response option 0 (NO), then standard ABx response packets are returned when a tag is read. If you choose option 1 or 2 (CR or CR/LF terminate), then the entire header and footer are removed from the response.

If you choose CR or CR/LF, then a carriage return (0DH) or carriage return line feed (0DH, 0AH) is append to the raw string of data from the tag. There is no header, length, command echo, footer, or checksum in this response string. Raw Read Response does not allow any delivery or data verification.

4.2.3 Download Software Updates

The microcontroller software can be updated by entering the 'Download New Program' mode and sending an Intel Hex file.

Also, the RF firmware can be updated, by means of the 'Download RF firmware' mode. Use the HFD.EXE Windows application on the PC.

Detailed download instructions are supplied with any custom or upgrade software.



5.1 Introduction

The LRP75 features RFID commands to perform the reading/writing of tag data. The standard commands are based on the established ABx protocol. Table 5-1 lists the standard commands available in the LRP75.

Table 5-1: Standard RFID Commands

Command Hex Equivalent	Command Name
04 Hex	Tag Fill
05 Hex	RF Port Block Read
06 Hex	RF Port Block Write
07 Hex	Read Tag Serial Number
08 Hex	Tag Search
0D Hex	Start/Stop Continuous Block Read
0E Hex	Read SN and Data
0F Hex	Start/Stop Continuous Read SN and Data

The LRP75 stores incoming bytes in a buffer and scans for a start character (AA Hex or <STX><STX>). When a start character is found, it will check for the terminating character (FFFF Hex or <ETX>). Having identified a potentially valid command string, the standard program will check the format of the data and either perform the requested function or generate an error message.

5.2 Command Timeout Values

Most commands sent to the LRP75 contain a timeout value field. This is the maximum number of milliseconds that a command will be attempted. If a command is not successfully completed within this time interval, a tag search error (08H) will be returned. When a command is successfully completed, the appropriate command response will be returned to the host. This will happen in less time than the timeout period.

For practical reasons (wakeup time, overhead) timeout values less than 30 ms have negligible effects on LRP75 behavior. Therefore, the examples given in this manual present the timeout range as 1EH to FFFE_H (30 to 65,534 ms).

Specifying a long timeout will not necessarily affect the time required to complete a command, but merely instructs the LRP75 how long to attempt the command before aborting. The timeout error is returned only if the command can not be successfully executed. For example, when the tag is not currently in the field.

Using a zero timeout value is not permitted and will return a syntax error (21H).

NOTE: During write commands, the tag must remain in the field until either the command completes successfully, or the timeout period has expired. If a write command is initiated with a tag in the antenna's active field and then the tag leaves the field before the command has completed or times out, data may be lost or corrupted. It is recommended that you use the longest timeout value permitted by the application.

For applications where the tag positioning may not be controlled and the tag movement cannot be limited to the antenna field, longer timeouts and retries should be utilized in the application program. This will ensure the highest success rates.

If an application demands the tag to travel at high speeds and retries can not be utilized, it may be required to synchronize the tag travel speed with the command timeouts. Use of a presence sensor may be required to ensure that the LRP75 cannot timeout while the tag is passing by. Many factors need to be considered for high speed applications such as; address range, command type, tag and antenna models, and the installation environment. Please contact Escort Memory Systems' application support team for help with your application.

5.3 Address Blocks

All read/write operations between the tag and the LRP75 are based on 4-byte block transfers. Each operation, whether it invokes a single data byte or 48 bytes, will read/write in multiples of four bytes.

This fact impacts timing issues in two cases:

- When the number of data bytes is not a multiple of 4.
- When the read or write does not start on one of the first block bytes (0, 4, 8 and so on).

In the first case, the RFID interface will first read all tag addresses affected by the transaction so that data not requested by the host is not returned or written to. For example, when you request a write to tag addresses 2 through 5 (4 bytes), the LRP will first read the tag data at addresses 0 through 7 (8 bytes), and then write to those addresses with the new data in addresses 2 through 5.

When a write or read operation is executed at a starting address other than the first byte of a block, the blocks with partial data will also be included in the operation. For example, a four byte read from an odd address will take twice as long since the LRP75 will read 8 bytes.

NOTE: To make your application as efficient as possible, design your tag accesses in 4-byte blocks starting on a the first byte of a block.

5.4 ABx Error Codes

The LRP75 returns an error if it encounters a fault during operation. Table 5-2 list the possible error codes in Hexadecimal format.

Table 5-2: ABx Error Codes

Error Code	Description
05H	Block Read has failed
06H	Block Write has failed
08H	Search Tag Operation failed
21H	Syntax error
0DH	Command Read error. You will receive a Command Read error if you send another command while the LRP75 is in Continuous Read mode.
0FH	Command Read SN and Data error. You will receive a Command Read error if you send another command while the LRP75 is in Continuous Read SN and Data mode.

5.4.1 ABx Standard Error Format

ABxS error codes are returned in the LSB of the second register passed to the PLC. The format of the error response is shown below.

Error Response from the LRP75	
MSB	LSB
AAH	FFH
00H	Error Code
FFH	FFH

A Block Write fail error message would appear as: AAFF 0006 FFFFH.

5.5 Command Descriptions

The LRP75 supports two forms of ABx RFID commands; ABx Standard and ABx Fast.

The ABx Standard is a binary protocol, word (2-byte oriented) so that the syntax table reports the Most Significant Byte (MSB) and the Least Significant Byte (LSB). In serial transmission the MSB is transmitted first. User data is passed only in the LSB meaning that one word is required for each byte of user data.

ABx Fast is byte oriented and uses both MSB and LSB to pass user data. This is more efficient as each work passes two bytes of user data.

5.6 ABx Standard Commands

5.6.1 Command 4 (04 Hex): Tag Fill

DESCRIPTION

Fill an RFID tag with a one byte value over multiple contiguous addresses.

DISCUSSION

This command is commonly used to clear an RFID tag's memory. It writes a one byte value repetitively across a specified range of tag addresses.

The fill function requires one data value byte, a starting address, and a fill length. It will then proceed to fill the tag with the data value byte, starting at the specified start address for the specified number of consecutive bytes. When Fill Length is set to 0, the LRP75 will write fill

data from the start address to the end of the tag's memory. The timeout value is given in 1 msec increments and can have a value of 1EH to FFEH (65,534 ms). When the timeout is set to 0, the LRP75 will return a syntax error.

Field	Description
Header	AAH
Command	Command number in Hex
Start Address	The tag address where the fill will start
Fill Length	The number of tag addresses to be filled
Timeout	Timeout value given in 1 ms units (1EH - FFEH)
Data Value Byte	The byte to be used as fill
Message Terminator	FFFFH

EXAMPLE

Writes 'A' (41H) to the tag starting at address 0005H for the following next consecutive 10 bytes. A timeout of 2 seconds (07D0H = 2000 x 1 msec increments) is set for the completion of the configuration.

Command from the Host		
MSB	LSB	Remarks
AAH	04H	Perform Command 4
00H	05H	Start Address = 0005H
00H	0AH	Fill Length = 10 bytes (000AH)
07H	D0H	Timeout value
00H	41H	Fill byte
FFH	FFH	Message Terminator

Response from the LRP75		
MSB	LSB	Remarks
AAH	04H	Command Echo
FFH	FFH	Message Terminator

5.6.2 Command 5 (05 Hex): Block Read

DESCRIPTION

Read a block of data from an RFID tag.

DISCUSSION

The RF Block Read command is used to read segments of data from contiguous areas of tag memory. It is capable of transferring the entire read/write address range of the tag to the host with one command. The timeout value is given in 1 msec increments and can have a value of 1EH to FFFE H. A timeout of 0 will return a syntax error.

The data read from the tag is returned in the LSB of the register, and the MSB is always 00H.

Field	Description
Header	AAH
Command	Command number in hex
Start Address	The tag address where the read will start
Read Length	The number of tag addresses to be read
Timeout	Timeout value given in 1 ms units (1EH - FFFE H)
Message Terminator	FFFFH

EXAMPLE

Reads 8 bytes of data from the tag starting at address 01H. A timeout of 2 seconds (07D0H = 2000 x 1 msec increments) is set for the completion of the Block Read.

Command from the Host		
MSB	LSB	Remarks
AAH	05H	Perform Command 5
00H	01H	Start Address = 0001H
00H	08H	Read Block Length = 8 bytes (0008H)
07H	D0H	Timeout value
FFH	FFH	Message Terminator

Response from the LRP75		
MSB	LSB	Remarks
AAH	05H	Command Echo
00H	52H	Read Data 1 = 52H
00H	46H	Read Data 2 = 46H
00H	49H	Read Data 3 = 49H
00H	44H	Read Data 4 = 44H
00H	20H	Read Data 5 = 20H
00H	54H	Read Data 6 = 54H
00H	61H	Read Data 7 = 61H
00H	67H	Read Data 8 = 67H
FFH	FFH	Message Terminator

5.6.3 Command 6 (06 Hex): Block Write

DESCRIPTION

Write a block of data to an RFID tag.

DISCUSSION

The RF Port Block Write command is used to write segments of data to contiguous areas of tag memory. It is capable of transferring up to 48 bytes of data. The timeout value is given in 1 msec increments and can have a value of 1EH to FFFEH. A timeout of 0 will return a syntax error.

The data to be written to the tag is contained in the LSB of the register, and the MSB is always 00H.

Field	Description
Header	AAH
Command	Command number in hex
Start Address	The tag address where the write will start
Write Length	The number of tag addresses to be written
Timeout	Timeout value given in 1 ms units (1EH - FFFEH)
Write Data	The data to be written
Message Terminator	FFFFH

EXAMPLE

Writes 4 bytes of data to the tag starting at address 0001H. A timeout of 2 seconds (07D0H = 2000 x 1 msec increments) is set for the completion of the Block Write.

Command from the Host			Response from the LRP75		
MSB	LSB	Remarks	MSB	LSB	Remarks
AAH	06H	Perform Command 6	AAH	06H	Command Echo
00H	01H	Start Address = 0001H	FFH	FFH	Message Terminator
00H	04H	Write Length= 4 bytes (0004H)			
07H	D0H	Timeout value			
00H	41H	Write Data 1 = 41H			
00H	46H	Write Data 2 = 46H			
00H	49H	Write Data 3 = 49H			
00H	44H	Write Data 4 = 44H			
FFH	FFH	Message Terminator			

5.6.4 Command 7 (07H): Read Tag Serial Number

DESCRIPTION

This command retrieves the 8-byte tag serial number.

DISCUSSION

Each LRP tag has a unique serial number. This number can not be changed and is not part of the 48 available data bytes. The tag serial number will be returned in the LSB only with the MSB as 00H. The timeout value is given in 1 msec increments and can have a value of 1EH to FFFEH.

Field	Description
Header	AAH
Command	Command number in hex
Timeout	Timeout value given in 1 ms units (1EH - FFFEH)
Message Terminator	FFFFH

EXAMPLE

This example reads the 8-byte serial number. In this example the serial number is 1E6E3DC200000001 in hexadecimal. A timeout of 2 seconds (07D0H = 2000 x 1 msec increments) is set for the completion of the Read Tag Serial Number.

Command from the Host			Response from the LRP75		
MSB	LSB	Remarks	MSB	LSB	Remarks
AAH	07H	Perform Command 7	AAH	07H	Command Echo
07H	D0H	Timeout value	00H	1EH	Tag ID byte 1
FFH	FFH	Message Terminator	00H	6EH	Tag ID byte 2
			00H	3DH	Tag ID byte 3
			00H	C2H	Tag ID byte 4
			00H	00H	Tag ID byte 5
			00H	00H	Tag ID byte 6
			00H	00H	Tag ID byte 7
			00H	01H	Tag ID byte 8
			FFH	FFH	Message Terminator

5.6.5 Command 8 (08 Hex): Tag Search

DESCRIPTION

Check to see if there is an RFID tag in the LRP75 field.

DISCUSSION

This command will activate the reader/write to "look" for a tag in the RF field. If the LRP75 finds a tag it will return a command echo to the host. The timeout value is given in 1 msec increments and can have a value of 1EH to FFFEH. If no tag is present it will return an error message.

Field	Description
Header	AAH
Command	Command number in hex
Timeout	Timeout value given in 1 ms units (1EH - FFFEH)
Message Terminator	FFFFH

EXAMPLE

Checks for an RFID tag in the RF field. A timeout of 2 seconds (07D0H = 2000 x 1 msec increments) is set for the completion of the Tag Search.

Command from the Host			Response from the LRP75		
MSB	LSB	Remarks	MSB	LSB	Remarks
AAH	08H	Perform Command 8	AAH	08H	Command Echo
07H	D0H	Timeout value	FFH	FFH	Message Terminator
FFH	FFH	Message Terminator			

5.6.6 Command D (0D Hex): Start/Stop Continuous Block Read

DESCRIPTION

When in Continuous Block Read mode, the LRP75 sends block read commands continuously to any tag in range of the antenna. The value in the length field controls the command (start/stop).

DISCUSSION

When a tag enters the field of the antenna, the LRP75 reads the specified data and passes it to the host. The LRP75 continues to read the tag, but will not send the same data to the host until the tag has been out of the antenna's range for a specified time period. This period is called the Delay Between Identical Reads. It prevents redundant data transmission when the LRP75 is in Continuous Block Read mode. The Delay Between Identical Reads can have an integral value in seconds between 0 and 60. A value of 0 makes the LRP75 continuously read any tag in the RF field and send the data to the host.

The LRP75 remains in Continuous Block Read mode until it receives a new continuous read command with a zero read length. To stop Continuous Block Read Mode, issue the Start/Stop Continuous Read command with a read length of zero (0).

If the LRP75 receives any other command from the host while performing continuous read, an error (0DH) will be sent to the host.

NOTE: Other commands will NOT be performed when the LRP75 is performing continuous read.

Field	Description
Header	AAH
Command	Command number in hex
Start Address	The tag address where the read will start
Read Length	The number of tag addresses to be read. A 0 length stops continuous mode.
Delay Between Identical Reads	Time period that the tag must be out of reading range before the LRP75 will send the same data to the host.
Message Terminator	FFFFH

EXAMPLE

The following example reads 8 bytes of data from a tag at address 05H, with a delay between identical reads of 2. After a tag is read, it must remain out of the RF field for at least 2 seconds before it will be read again. The LRP75 will send a response confirming its in Continuous Block Read mode.

Command from the Host		
MSB	LSB	Remarks
AAH	0DH	Perform Command D
00H	05H	Start Address
00H	08H	Read Length
00H	02H	Delay Between Identical Reads
FFH	FFH	Message Terminator

Response from the LRP75		
MSB	LSB	Remarks
AAH	0DH	Command Echo
FFH	FFH	Message Terminator

When a tag arrives, the LRP will send the requested tag data.

Command from the Host		
MSB	LSB	Remarks
AAH	0DH	Command Echo
00H	44H	Data byte 1
00H	20H	Data byte 2
00H	54H	Data byte 3
00H	61H	Data byte 4
00H	67H	Data byte 5
00H	20H	Data byte 6
00H	20H	Data byte 7
00H	20H	Data byte 8
FFH	FFH	Message Terminator

5.6.7 Command E (0EH) Read SN and Data

DESCRIPTION

Command E reads the tag's Serial Number along with tag data, and sends it back to the host in one response packet. If the length is zero (0), then only the Serial Number is returned to the host.

Field	Description
Header	AAH
Command	Command number in hex
Start Address	The tag address where the read will start
Read Length	The number of tag addresses to be read
Timeout	Timeout value given in 1 ms units (1EH - FFFEH)
Message Terminator	FFFFH

EXAMPLE

The below example reads the SN and one data byte at tag address five (05H), with a two second timeout. The tag data is 20H.

Command from the Host			Response from the LRP75		
MSB	LSB	Remarks	MSB	LSB	Remarks
AAH	0EH	Perform Command E	AAH	0EH	Command Echo
00H	05H	Start Address	00H	7DH	Serial Number byte 1
00H	01H	Read Length	00H	EFH	Serial Number byte 2
07H	D0H	2 Second Timeout	00H	4CH	Serial Number byte 3
FFH	FFH	Message Terminator	00H	00H	Serial Number byte 4
			00H	00H	Serial Number byte 5
			00H	00H	Serial Number byte 6
			00H	00H	Serial Number byte 7
			00H	01H	Serial Number byte 8
			00H	20H	Data byte
			FFH	FFH	Message Terminator

5.6.8 Command F (0FH) Start/Stop Continuous Read SN and Data

DESCRIPTION

When in Continuous Block Read SN and Data mode, the LRP75 sends Read SN and Data commands continuously to any tag in range of the antenna. The value in the Start/Stop field controls the command (start/stop).

DISCUSSION

When a tag enters the field of the antenna, the LRP75 reads the SN and data, and then passes them to the host. The LRP75 continues to read the tag, but will not send the same data to the host until the tag has been out of the antenna's range for a specified time period. This period is called the Delay Between Identical Reads. It prevents redundant data transmission when the LRP75 is in Continuous Read SN and Data mode. The Delay Between Identical Reads can have an integral value in seconds between 0 and 60. A value of 0 makes the LRP75 continuously read any tag in the RF field and send the data to the host.

The Start/Stop Continuous Read SN and Data command has a field to start and stop continuous reading. To stop Continuous Read SN and Data, issue the command with zero (0) in the start/stop byte.

If the LRP75 receives any other command from the host while in continuous mode, an error (0FH) will be sent to the host.

NOTE: Other commands will NOT be performed when the LRP75 is in continuous mode.

Field	Description
Header	AAH
Command	Command number in hex
Start Address	The tag address where the read will start
Read Length	The number of tag addresses to be read
Delay Between Identical Reads	Time period that the tag must be out of reading range before the LRP75 will send the same data to the host.
Start/Stop	01H starts continuous mode and 00H stops it.
Message Terminator	FFFFH

EXAMPLE

This example will wait until a tag is in range and then reads 2 bytes of data from the tag starting at address 05H.

Command from the Host		
MSB	LSB	Remarks
AAH	0FH	Perform Command F
00H	05H	Start Address = 0005H
00H	02H	Read Length = 2 bytes
00H	0AH	10 second delay between identical reads
00H	01H	Start Continuous mode
FFH	FFH	Message Terminator

Response from the LRP75		
MSB	LSB	Remarks
AAH	0FH	Command Echo
FFH	FFH	Message Terminator

When a tag comes into range of the LRP75, it will perform the read and return the data as follows.

Response from the LRP75		
MSB	LSB	Remarks
AAH	0FH	Command Echo
00H	52H	Serial Number 1 = 52H
00H	46H	Serial Number 2 = 46H
00H	49H	Serial Number 3 = 49H
00H	44H	Serial Number 4 = 44H
00H	50H	Serial Number 5 = 50H
00H	51H	Serial Number 6 = 51H
00H	53H	Serial Number 7 = 53H
00H	01H	Serial Number 8 = 01H
00H	55H	Data Byte 1 = 55H
00H	56H	Data Byte 2 = 56H
FFH	FFH	Message Terminator

5.7 ABx Fast Commands

The difference from the standard ABx are:

- The command/response packet contains the packet size
- You can include a checksum in the command
- The headers and terminator are ASCII characters

Since ABx Fast is a binary protocol, the Xon/Xoff handshake cannot be used.

5.7.1 ABx Command Packet Structure

The command protocol is based on the following minimal packet structure. The data field and the checksum may not be present depending on the command type and your checksum setting.

Field	Number of Bytes	Description
Header	2	<STX><STX> (02H, 02H)
Command Size	2	Packet length in bytes excluding the header, command size, checksum and terminator bytes.
Command	1	Command Code (XXH)
(Data)	variable	Command parameters/data
Checksum	1	Optional Checksum
Terminator	1	<ETX> (03H)

Following a successful operation, the LRP75 will respond with the following. The data field and the checksum may not be present depending on the command and checksum setting.

Field	Number of Bytes	Description
Header	2	<STX><STX> (02H, 02H)
Response Size	2	Packet length in bytes excluding the header, command size, checksum and terminator bytes.
Command Echo	1	Command Echo (XXH)
(Data)	variable	Response data
Checksum	1	Optional Checksum
Terminator	1	<ETX> (03H)

If the LRP75 encounters a fault, it will respond with the following:

Field	Number of Bytes	Description
Header	2	<STX><STX> (02H, 02H)
Response Size	2	Packet length in bytes excluding the header, command size, checksum and terminator bytes.
Error Flag	1	FFH
Error Code	1	Hex error code
Checksum	1	Optional Checksum
Terminator	1	<ETX> (03H)

- The Header and Terminator are always STX-STX and ETX respectively.
- All other bytes are interpreted as binary data (0 - 255 dec).
- Fields with two bytes are sent most significant byte (MSB) first.

The sequence for each command is given with the response format in the following section.

Command/Response Size

The ABx Fast requires that the length of the packet be included in the command. All parameters and data between the Command/Response Size and the Checksum or Terminator bytes must be accounted for in the command/response size word. This includes all command codes and parameters such as field definitions for Block Read/Writes. The command/response size will be the same with, or without, a checksum.

Checksum

The optional checksum must be enabled from the operating mode menu to be available. The checksum is calculated by adding all the byte values in the packet (less the values in the header, checksum if present, and terminator), discarding byte overflow and subtracting the byte sum from FFH. Thus, when the packet length through the checksum are added as byte values, the sum will be FFH.

EXAMPLE

The following is a typical command using a checksum.

Command from Host	
Field	Contents
Header <STX><STX>	02H
	02H
Command Size	00H
	03H
Command Code	01H
Timeout	07H
	D0H
Checksum	24H
Terminator <ETX>	03H

Sum these values to calculate the checksum

The summed values begin with the Command Size and end with the timeout value. That sum, less overflow, is subtracted from FFH for the checksum value.

Thus: $00 + 03 + 01 + 07 + D0 = DB$

$FF - DB = 24H$

5.7.2 Command 4 (04 Hex): Tag Fill

DESCRIPTION

Fill an RFID tag with a one byte value over multiple contiguous addresses.

DISCUSSION

This command is commonly used to clear an RFID tag's memory. It writes a one byte value repetitively across a specified range of tag addresses.

The fill function requires one data value byte, a starting address, and a fill length. It will then proceed to fill the tag with the data value byte, starting at the specified start address for the specified number of consecutive bytes.

The timeout value is given in 1 msec increments and can have a value of 1EH to FFFE H (65,534 ms). When the timeout is set to 0, the LRP75 will return a syntax error.

Field	Description
Header	<STX><STX>
Command Size	Packet length in bytes, excluding the header, command size, checksum and terminator bytes.
Command	04H
Start Address	2-byte value for the tag address where the fill will start
Fill Length	2-byte value for the number of tag addresses to be filled
Timeout	2-byte timeout value given in 1 ms units (1EH - FFFE H)
Data Value Byte	The byte to be used as fill
Checksum	optional checksum
Message Terminator	FFFFH

A response to a successful command will follow this form.

Field	Description
Header	<STX><STX>
Response Size	Packet length in bytes, excluding the header, command size, checksum and terminator bytes.
Command Echo	04H
Checksum	optional checksum
Message Terminator	FFFFH

EXAMPLE

Writes 'A' (41H) to the tag starting at address 0005H for the following next consecutive 10 bytes. A timeout of 2 seconds (07D0H = 2000 x 1 msec increments) is set for the completion of the configuration.

Command from the Host	
Field	Contents
Header	02H
	02H
Command Size	00H
	08H
Command Code	04H
Start Address	00H
	05H
Fill Length	00H
	0AH
Timeout, 2 seconds	07H
	D0H
Fill byte	41H
Terminator <ETX>	03H

Response from the LRP75	
Field	Contents
Header	02H
	02H
Response Size	00H
	01H
Command Echo	04H
Terminator <ETX>	03H

5.7.3 Command 5 (05 Hex): Block Read

DESCRIPTION

Read a block of data from an RFID tag.

DISCUSSION

The RF Block Read command is used to read segments of data from contiguous areas of tag memory. It is capable of transferring the entire read/write address range of the tag to the host with one command. The timeout value is given in 1 msec increments and can have a value of 1EH to FFFE H. A timeout of 0 will return a syntax error.

The data read from the tag is returned in the LSB of the register, and the MSB is always 00H.

Field	Description
Header	<STX><STX>
Command Size	Packet length in bytes, excluding the header, command size, checksum and terminator bytes.
Command	05H
Start Address	2-byte value for the tag address where the read will start.
Read Length	2-byte value for the number of tag addresses to be read.
Timeout	2-byte timeout value given in 1 ms units (1EH - FFFE H)
Checksum	optional checksum
Message Terminator	FFFFH

EXAMPLE

Reads 4 bytes of data from the tag starting at address 01H. A timeout of 2 seconds (07D0H = 2000 x 1 msec increments) is set for the completion of the Block Read.

Command from the Host	
Field	Contents
Header	02H
	02H
Command Size	00H
	07H
Command Code	05H
Start Address	00H
	01H
Read Length	00H
	04H
Timeout, 2 seconds	07H
	D0H
Terminator <ETX>	03H

Response from the LRP75	
Field	Contents
Header	02H
	02H
Response Size	00H
	05H
Command Echo	05H
Data from address 0001H	05H
Data from address 0002H	AAH
Data from address 0003H	E7H
Data from address 0004H	0AH
Terminator <ETX>	03H

5.7.4 Command 6 (06 Hex): Block Write

DESCRIPTION

Write a block of data to an RFID tag.

DISCUSSION

The RF Port Block Write command is used to write segments of data to contiguous areas of tag memory. It is capable of transferring up to 48 bytes of data. The timeout value is given in 1 msec increments and can have a value of 1EH to FFEH. A timeout of 0 will return a syntax error.

The data to be written to the tag is contained in the LSB of the register, and the MSB is always 00H.

Field	Description
Header	<STX><STX>
Command Size	Packet length in bytes, excluding the header, command size, checksum and terminator bytes.
Command	06H
Start Address	2-byte value for the tag address where the write will start.
Write Length	2-byte value for the number of tag addresses to be written to.
Timeout	2-byte timeout value given in 1 ms units (1EH - FFEH)
Data	Data bytes to be written
Checksum	optional checksum
Terminator	<ETX>

EXAMPLE

Writes 4 bytes of data to the tag starting at address 0001H. A timeout of 2 seconds (07D0H = 2000 x 1 msec increments) is set for the completion of the Block Write.

Command from the Host	
Field	Contents
Header	02H
	02H
Command Size	00H
	0BH
Command Code	06H
Start Address	00H
	01H
Write Length	00H
	04H
Timeout, 2 seconds	07H
	D0H
Data to write to address 0001H	52H
Data to write to address 0002H	46H
Data to write to address 0003H	49H
Data to write to address 0004H	44H
Terminator <ETX>	03H

Response from the LRP75	
Field	Contents
Header	02H
	02H
Response Size	00H
	01H
Command Echo	06H
Terminator <ETX>	03H

5.7.5 Command 7 (07H): Read Tag Serial Number

DESCRIPTION

This command retrieves the 8-byte tag serial number.

DISCUSSION

Each LRP tag has a unique serial number. This number can not be changed and is not part of the 48 available data bytes. The tag serial number will be returned in the LSB only with the MSB as 00H. The timeout value is given in 1 msec increments and can have a value of 1EH to FFFE H.

Field	Description
Header	<STX><STX>
Command Size	Packet length in bytes, excluding the header, command size, checksum and terminator bytes.
Command	07H
Timeout	2-byte timeout value given in 1 ms units (1EH - FFFE H)
Checksum	optional checksum
Message Terminator	FFFFH

EXAMPLE

This example reads the 8-byte serial number. In this example the serial number is 1E6E3DC200000001 in hexadecimal. A timeout of 2 seconds (07D0H = 2000 x 1 msec increments) is set for the completion of the Read Tag Serial Number.

Command from the Host	
Field	Contents
Header	02H
	02H
Command Size	00H
	03H
Command Code	07H
Timeout, 2 seconds	07H
	D0H
Terminator <ETX>	03H

Response from the LRP75	
Field	Contents
Header	02H
	02H
Response Size	00H
	09H
Command Echo	07H
SN Byte 1	1EH
SN Byte 2	6EH
SN Byte 3	3DH
SN Byte 4	C2H
SN Byte 5	00H
SN Byte 6	00H
SN Byte 7	00H
SN Byte 8	01H
Terminator <ETX>	03H

5.7.6 Command 8 (08 Hex): Tag Search

DESCRIPTION

Check to see if there is an RFID tag in the LRP75 field.

DISCUSSION

This command will activate the reader/write to "look" for a tag in the RF field. If the LRP75 finds a tag it will return a command echo to the host. The timeout value is given in 1 msec increments and can have a value of 1EH to FFFE H. If no tag is present it will return an error message.

Field	Description
Header	<STX><STX>
Command Size	Packet length in bytes, excluding the header, command size, checksum and terminator bytes.
Command	08H
Timeout	2-byte timeout value given in 1 ms units (1EH - FFFE H)
Checksum	optional checksum
Message Terminator	FFFFH

EXAMPLE

Checks for an RFID tag in the RF field. A timeout of 2 seconds (07D0H = 2000 x 1 msec increments) is set for the completion of the Tag Search.

Command from the Host	
Field	Contents
Header	02H
	02H
Command Size	00H
	03H
Command Code	08H
Timeout, 2 seconds	07H
	D0H
Terminator <ETX>	03H

Response from the LRP75	
Field	Contents
Header	02H
	02H
Response Size	00H
	01H
Command Echo	08H
Terminator <ETX>	03H

5.7.7 Command D (0D Hex): Start/Stop Continuous Block Read

DESCRIPTION

When in Continuous Block Read mode, the LRP75 sends block read commands continuously to any tag in range of the antenna. The value in the length field controls the command (start/stop).

DISCUSSION

When a tag enters the field of the antenna, the LRP75 reads the specified data and passes it to the host. The LRP75 continues to read the tag, but will not send the same data to the host until the tag has been out of the antenna's range for a specified time period. This period is called the Delay Between Identical Reads. It prevents redundant data transmission when the LRP75 is in Continuous Block Read mode. The Delay Between Identical Reads can have an integral value in seconds between 0 and 60. A value of 0 makes the LRP75 continuously read any tag in the RF field and send the data to the host.

The LRP75 remains in Continuous Block Read mode until it receives a new continuous read command with a zero read length. To stop Continuous Block Read Mode, issue the Start/Stop Continuous Read command with a read length of zero (0).

If the LRP75 receives any other command from the host while performing continuous read, an error (0DH) will be sent to the host.

NOTE: Other commands will NOT be performed when the LRP75 is performing continuous read.

Field	Description
Header	<STX><STX>
Command Size	Packet length in bytes, excluding the header, command size, checksum and terminator bytes.
Command	0DH
Start Address	2-byte value for the tag address where the read will start
Read Length	2-byte value for the length of the read
Delay Between Identical Reads	1-byte delay (0-60 seconds)
Checksum	optional checksum
Message Terminator	FFFFH

EXAMPLE

The following example reads 4 bytes of data from a tag at address 05H, with a delay between identical reads of 2. After a tag is read, it must remain out of the RF field for at least 2 seconds before it will be read again. The LRP75 will send a response confirming its in Continuous Block Read mode.

Command from the Host	
Field	Contents
Header	02H
	02H
Command Size	00H
	06H
Command Code	0DH
Start Address	00H
	05H
Read Length	00H
	04H
Delay Between Identical Decodes	02H
Terminator <ETX>	03H

Response from the LRP75	
Field	Contents
Header	02H
	02H
Response Size	00H
	01H
Command Echo	0DH
Terminator <ETX>	03H

When a tag arrives, the LRP will send the requested tag data.

Response from the LRP75	
Field	Contents
Header	02H
	02H
Response Size	00H
	05H
Command Echo	0DH
Data from address 0005H	05H
Data from address 0006H	AAH
Data from address 0007H	E7H
Data from address 0008H	0AH
Terminator <ETX>	03H

5.7.8 Command E (0EH) Read SN and Data

DESCRIPTION

Command E reads the tag's Serial Number along with tag data, and sends it back to the host in one response packet. If the length is zero (0), then only the Serial Number is returned to the host.

Field	Description
Header	<STX><STX>
Command Size	Packet length in bytes, excluding the header, command size, checksum and terminator bytes.
Command	0EH
Start Address	2-byte value for the tag address where the read will start
Read Length	2-byte value for the length of the read
Timeout	2-byte timeout value given in 1 ms units (1EH - FFFEH)
Checksum	optional checksum
Message Terminator	FFFFH

EXAMPLE

The below example reads the SN and one data byte at tag address five (05H), with a two second timeout. The tag data is 20H.

Command from the Host	
Field	Contents
Header	02H
	02H
Command Size	00H
	05H
Command Code	0EH
Start Address	00H
	05H
Read Length	00H
	01H
Timeout	07H
	D0H
Terminator <ETX>	03H

Response from the LRP75	
Field	Contents
Header	02H
	02H
Response Size	00H
	0AH
Command Echo	0EH
SN Byte 1	1EH
SN Byte 2	6EH
SN Byte 3	3DH
SN Byte 4	C2H
SN Byte 5	00H
SN Byte 6	00H
SN Byte 7	00H
SN Byte 8	01H
Data Byte	20H
Terminator <ETX>	03H

5.7.9 Command F (0FH) Start/Stop Continuous Read SN and Data

DESCRIPTION

When in Continuous Block Read Serial Number and Data mode, the LRP75 sends Read SN and Data commands continuously to any tag in range of the antenna. The value in the Start/Stop field controls the command (start/stop).

DISCUSSION

When a tag enters the field of the antenna, the LRP75 reads the SN and data, and then passes them to the host. The LRP75 continues to read the tag, but will not send the same data to the host until the tag has been out of the antenna's range for a specified time period. This period is called the Delay Between Identical Reads. It prevents redundant data transmission when the LRP75 is in Continuous Read SN and Data mode. The Delay Between Identical Reads can have an integral value in seconds between 0 and 60. A value of 0 makes the LRP75 continuously read any tag in the RF field and send the data to the host.

The Start/Stop Continuous Read SN and Data command has a field to start and stop continuous reading. To stop Continuous Read SN and Data, issue the command with zero (0) in the start/stop byte.

If the LRP75 receives any other command from the host while in continuous mode, an error (0FH) will be sent to the host.

NOTE: Other commands will NOT be performed when the LRP75 is in continuous mode.

Field	Description
Header	<STX><STX>
Command Size	Packet length in bytes, excluding the header, command size, checksum and terminator bytes.
Command	0FH
Start Address	2-byte value for the tag address where the read will start
Read Length	2-byte value for the length of the read
Delay Between Identical Reads	1-byte delay (0-60 seconds)
Start/Stop Byte	01H starts continuous mode and 00H stops it.
Checksum	optional checksum
Message Terminator	FFFFH

EXAMPLE

This example will wait until a tag is in range and then reads 2 bytes of data from the tag starting at address 05H.

Command from the Host	
Field	Contents
Header	02H
	02H
Command Size	00H
	07H
Command Code	0FH
Start Address	00H
	05H
Read Length	00H
	02H
Delay Between Identical Decodes	02H
Start/Stop Byte	01H
Terminator <ETX>	03H

Response from the LRP75	
Field	Contents
Header	02H
	02H
Response Size	00H
	01H
Command Echo	0FH
Terminator <ETX>	03H

When a tag comes into range of the LRP75, it will perform the read and return the data as follows.

Response from the LRP75	
Field	Contents
Header	02H
	02H
Response Size	00H
	0BH
Command Echo	0EH
SN Byte 1	1EH
SN Byte 2	6EH
SN Byte 3	3DH
SN Byte 4	C2H
SN Byte 5	00H
SN Byte 6	00H
SN Byte 7	00H
SN Byte 8	01H
Data Byte 1	20H
Data Byte 2	20H
Terminator <ETX>	03H



Appendix A

Technical Specifications

A.1 Electrical Characteristics

Power Voltage	24 Vdc +/- 10%
Consumption	250 mA max.

A.2 Physical Characteristics

Dimensions (L x W x H)	4.125 x 2.125 x 1.5"
Enclosure	ABS

A.3 Environmental

Protection Class	NEMA 2
------------------	--------

A.4 Communication Characteristics

RF Interface	LRP-Series Passive RFID System
COM1	RS232/RS422

This page left blank intentionally.



Appendix B LRP75 Beta Connections

Early models of the LRP75 have two terminal blocks for power and serial communication. If you are wiring a LRP75 Beta unit, use the pinouts given in this appendix.

B.1 Internal Junction Blocks

The LRP75 is connected to external power and communications cabling through two internal terminal blocks. The power and serial communication junction blocks accept AWG 22-14 wires.

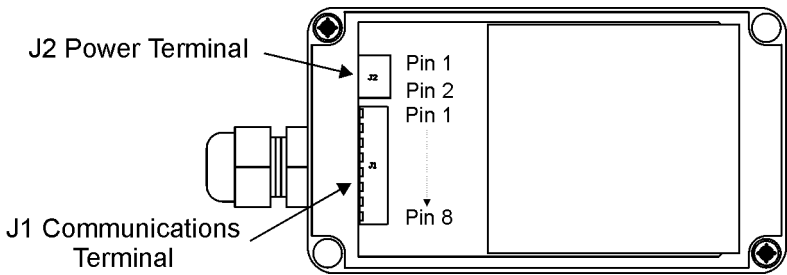

Figure B-1. Internal junction block

B.2 Power Connections

Connection to power is through the internal J2 terminal block.

Table 5-3: J2 Power Connection

Terminal	Description
1	+24 Vdc
2	Power Ground

B.3 Serial Connections

The Prod Nm can be wired to communication with the host either through an RS232 or RS422 interface. Connection to the serial interface is through the J1 terminal shown in Figure B-1 on page -57. Connect the signal ground to terminal 2 on the J2 power terminal.

Table 5-4 gives the pinouts for the J1 terminal block.

Table 5-4: J1 Serial Communications Pinouts

Terminal	Function
1	Reserved, no connection
2	Reserved, no connection
3	RS232 RX (from host DB9, pin 3)
4	RS232 TX (from host DB9, pin 2)
5	RS422 RX +
6	RS422 TX +
7	RS422 RX -
8	RS422 TX -
J2, pin 2	Connect the signal ground to pin 2 of terminal block J2

For more information on power requirements and serial communication options, see Chapter 3, *Power and Electrical Interface*.



Appendix C Models and Accessories

Model	Description
LRP75	Long Range Passive Reader/Writer for LRP-Series tags

LRP Series RFID Tags	Description
LRP125	Long-range passive read/write tag, 25 mm dia. round, 48 bytes memory
LRP125HT	Long-range passive read/write tag, 25 mm dia. round, 48 bytes memory, survives 240° temperatures
LRP250	Long-range passive read/write tag, 50 mm square, 48 bytes memory
LRP250HT	Long-range passive read/write tag, 50 mm square, 48 bytes memory, survives 240° temperatures
LRP125HT-FLX	Long-range passive read/write tag, 25 mm dia. round, 48 bytes memory, survives 240° temperatures, flexible with high temperature adhesive backing
LRP250HT-FLX	Long-range passive read/write tag, 50 mm dia. round, 48 bytes memory, survives 240° temperatures, flexible with high temperature adhesive backing
LRP-L5555	Long-range passive read/write tag, 55 mm square, 48 bytes memory, thermal transfer with adhesive backing
LRP-L2666	Long-range passive read/write tag, 26 x 66 mm, 48 bytes memory, thermal transfer with adhesive backing
LRP-L4982	Long-range passive read/write tag, 49 x 82 mm, 48 bytes memory, thermal transfer with adhesive backing
LRP-P125	Long-range passive read/write tag, 25 mm square, 48 bytes memory, PCB
LRP-P3858	Long-range passive read/write tag, 38 x 58 mm, 48 bytes memory, PCB
LRP-P5050	Long-range passive read/write tag, 50 mm square, 48 bytes memory, PCB

This page left blank intentionally.



Appendix D ASCII Chart

Decimal	Hex	Character
000	00	NUL
001	01	SOH
002	02	STX
003	03	ETX
004	04	EOT
005	05	ENQ
006	06	ACK
007	07	BEL
008	08	BS
009	09	HT
010	0A	LF
011	0B	VT
012	0C	FF
013	0D	CR
014	0E	SO
015	0F	SI
016	10	DLE
017	11	DC1
018	12	DC2
019	13	DC3
020	14	DC4
021	15	NAK
022	16	SYN
023	17	ETB
024	18	CAN
025	19	EM
026	1A	SUB
027	1B	ESC
028	1C	FS
029	1D	GS
030	1E	RS
031	1F	US

Decimal	Hex	Character
032	20	(SPACE)
033	21	!
034	22	"
035	23	#
036	24	\$
037	25	%
038	26	&
039	27	'
040	28	(
041	29)
042	2A	*
043	2B	+
044	2C	,
045	2D	-
046	2E	.
047	2F	/
048	30	0
049	31	1
050	32	2
051	33	3
052	34	4
053	35	5
054	36	6
055	37	7
056	38	8
057	39	9
058	3A	:
059	3B	;
060	3C	<
061	3D	=
062	3E	>
063	3F	?

ASCII Chart

Decimal	Hex	Character
064	40	@
065	41	A
066	42	B
067	43	C
068	44	D
069	45	E
070	46	F
071	47	G
072	48	H
073	49	I
074	4A	J
075	4B	K
076	4C	L
077	4D	M
078	4E	N
079	4F	O
080	50	P
081	51	Q
082	52	R
083	53	S
084	54	T
085	55	U
086	56	V
087	57	W
088	58	X
089	59	Y
090	5A	Z
091	5B	[
092	5C	\
093	5D]
094	5E	^
095	5F	_

Decimal	Hex	Character
096	60	`
097	61	a
098	62	b
099	63	c
100	64	d
101	65	e
102	66	f
103	67	g
104	68	h
105	69	i
106	6A	j
107	6B	k
108	6C	l
109	6D	m
110	6E	n
111	6F	o
112	70	p
113	71	q
114	72	r
115	73	s
116	74	t
117	75	u
118	76	v
119	77	w
120	78	x
121	79	y
122	7A	z
123	7B	{
124	7C	
125	7D	}
126	7E	~
127	7F	DEL