

# User Manual

## BandLuxe

K530 Series  
LTE M2M &  
Vehicle Mount  
Router

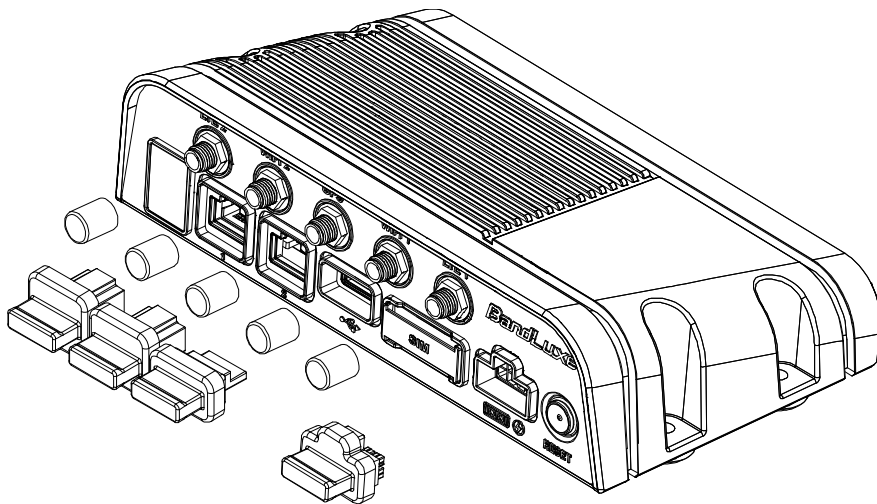

P/N:64003700011 Rev.D

**BandLuxe™**



---

# Table of Contents

<b>Package Contents .....</b>	<b>4</b>
Package Contents.....	4
Optional Accessories.....	5
Features.....	6
Hardware Overview.....	6
<b>Installation.....</b>	<b>8</b>
<b>Using Web-based Management.....</b>	<b>12</b>
Status .....	13
Overview .....	13
System .....	14
Network .....	14
DHCP Leases.....	14
Local Network.....	14
System Log .....	15
GPS .....	15
VnStat Traffic Monitor .....	15
Graphs.....	16
Configuration.....	16
Mobile Internet .....	17
Information .....	17
Signal Quality.....	17
U/SIM Status.....	17
Registered Network .....	18
Internet Connection .....	18
Debug.....	18
Debug .....	19
System .....	20
System .....	20
System Properties.....	20
General Settings.....	20
Language and Style.....	21
Time Synchronization.....	21
Remote System Log.....	21
Administration .....	22
Router Password.....	22
Remote Access .....	22
Backup / Flash Firmware.....	23
Backup / Restore.....	23
Download backup .....	23
Reset to defaults.....	24
Restore backup.....	24
Flash new firmware image .....	24
Flash new module firmware image .....	24
Flash new ipkg package.....	24
FOTA .....	24
Reboot .....	25
Services .....	26
Dynamic DNS.....	26

Network Shares .....	27
Samba .....	27
General Settings .....	27
Edit template .....	28
Shared Directories .....	28
Network .....	29
Interfaces .....	29
Interface Overview .....	29
Common Configuration .....	30
General Setup .....	30
Advanced Settings .....	31
Physical Settings .....	31
Firewall Settings .....	31
Hotspot .....	32
Chillispot .....	32
Mobile Internet .....	33
WWAN Setting .....	34
Network Settings .....	34
Reset Modem .....	35
Manually Update Phone Number .....	35
Manually Update MSID .....	35
Manually Update MIP Profile .....	35
eHRPD Menu .....	35
Enable LTE .....	35
U/SIM PIN Management .....	36
Scenario 1: No mobile internet service .....	36
Scenario 2: Mobile internet service pending .....	36
Scenario 3: Mobile internet service enabled .....	37
SIM Management .....	39
Scenario 1: SIM lock absent .....	39
Scenario 2: SIM lock present .....	39
Preferred Network .....	39
AT command .....	40
Router .....	40
Router Settings .....	40
Router IP .....	40
DHCP Service .....	41
Active DHCP Leases .....	42
Static Leases .....	42
Advanced Routing settings .....	43
Static Routing .....	43
Routing and Redirection Service .....	44
VPN Passthrough .....	44
WiFi .....	45
Device Configuration .....	45
General Setup .....	45
Advanced Settings .....	47
Interface Configuration .....	47
General Setup .....	47
Wireless Security .....	48
MAC-Filter .....	52
Advanced Settings .....	53
Switch .....	54
Switch "eth0" (AR934X built-in switch) .....	54
VLAN on "eth0" (AR934X built-in switch) .....	54
Diagnostics .....	56

Network Utilities.....	56
Ping.....	56
Traceroute.....	56
NS Lookup.....	57
Firewall.....	58
Single Port Forward.....	58
Single Port Forward.....	58
Port Trigger.....	60
Port Trigger.....	60
Security Filter.....	62
Firewall.....	62
Internet Filter.....	62
Web Filters.....	63
DMZ Host.....	63
IP Filtering.....	64
IP Filtering.....	64
Port Range Forward.....	66
Port Range Forward.....	66
UPNP.....	68
UPnP Settings.....	68
VPN.....	68
IPSec Setting.....	68
IPSec VPN Connection.....	68
IPSec Profile.....	69
IPSec profile Overview.....	69
IPSec VPN connection status.....	69
IPSec Certificate.....	69
IPSec VPN Connection.....	69
SSL VPN.....	70
Help.....	71
Logout.....	71
<b>Appendix A: Vehicle Installation Guide.....</b>	<b>72</b>
Overview.....	72
Installation.....	74
General Guidelines.....	74
Mounting.....	75
Basic Power Management.....	76
Power Management with a Filter.....	77
<b>Appendix B: FAQ.....</b>	<b>79</b>
<b>Appendix C: Specifications.....</b>	<b>86</b>
<b>Appendix D: Important Safety Information and Glossary.....</b>	<b>90</b>
Europe – EU Declaration of Conformity.....	90
Federal Communication Commission Interference Statement.....	91
Glossary.....	93

# Package Contents

Thank you for your purchase of this LTE M2M & Vehicle Mount Router. This product is designed to access the Internet via 4G technology and share the bandwidth through a Wi-Fi network. It is easy to configure and operate even for non-technical users. This manual contains instructions for installing and configuring the product. Read the manual carefully before you use the product, so that you can fully exploit the product functions.

## Package Contents

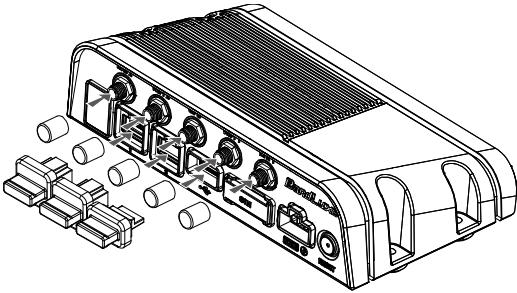
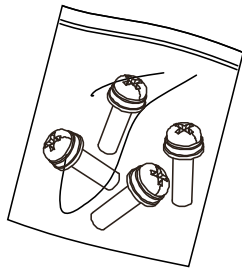
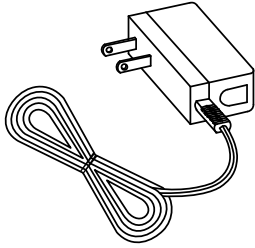
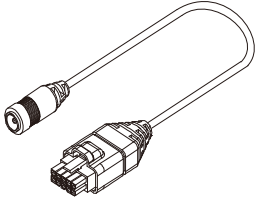
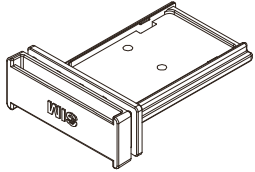
		
<i>BandLuxe K530 LTE/HSPA+ WiFi Router with GPS and Waterproof Connector Protective Caps</i>		<i>Mounting Screws</i>
		
<i>Power Adapter</i>	<i>Power Adapter Cable</i>	<i>Mini-SIM Card Tray</i>

## Optional Accessories

		
<p><i>Waterproof Active GPS antenna</i></p>	<p><i>Waterproof Magnetic base LTE antenna</i></p>	
		
<p><i>Stick-type WiFi antenna (for direct plug in)</i></p>	<p><i>Swivel LTE antenna (without base, for direct plug in)</i></p>	<p><i>Automobile Cigarette lighter power converter</i></p>

# Features

- LTE\* Cat3 and 3GPP Rel9 compatible with HSPA+ or EVDO fallback support (\*: LTE is a trademark of ETSI.)
- High performance module and router platform targeted for m2m and mission critical applications
- IP 64 and MIL 810G rugged design for extreme environments
- Operation temperature: -20°C to 70°C (-4°F to 158 °F)
- Input voltage: 12V or 24V DC, accepting 9-32V voltage swing
- 802.11 b/g/n 2x2 MIMO wireless networking
- Six status LEDs, two Ethernet ports, and one USB port
- IPsec VPN client and VPN pass-through modes
- Composite GPS and Glonass features for quicker positioning location and better accuracy

# Hardware Overview

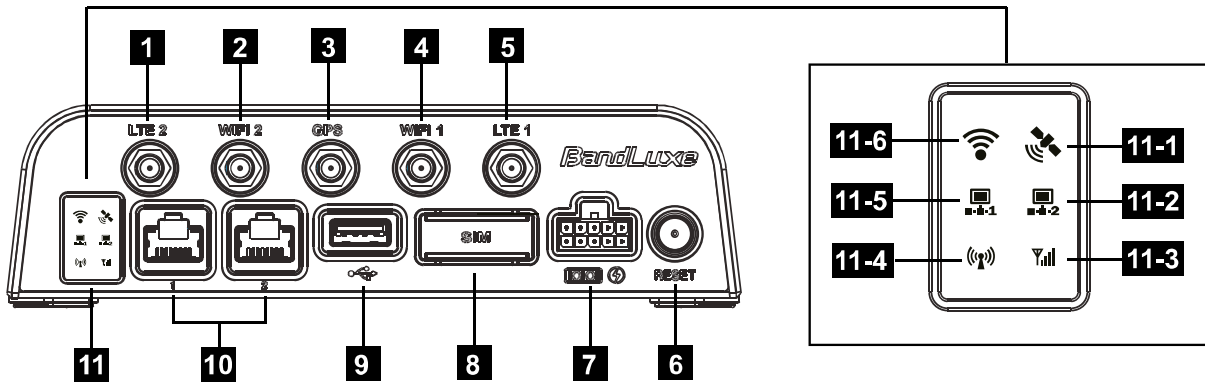

- |          |                                   |   |
|----------|-----------------------------------|---|
| <b>1</b> | <b>4G External Antenna Port 2</b> | Connect the second 4G External Antenna.   |
| <b>2</b> | <b>WiFi 2</b>                     | Connect the second WiFi External Antenna. |
| <b>3</b> | <b>GPS</b>                        | Connect the GPS External Antenna.         |
| <b>4</b> | <b>WiFi 1</b>                     | Connect the WiFi External Antenna.        |
| <b>5</b> | <b>4G External Antenna Port 1</b> | Connect the 4G External Antenna.          |



---

<b>6</b>	<b>Reset Button</b>	Press this button to reboot the router.
<b>7</b>	<b>Power Connector</b>	Connect the power adapter cable here.
<b>8</b>	<b>SIM Card Tray Slot</b>	Insert the loaded SIM card tray here for mobile internet connection.
<b>9</b>	<b>USB Port</b>	Connect the USB device here.
<b>10</b>	<b>LAN Ports 1 and 2</b>	Connect the LAN device(s) as needed.
<b>11</b>	<b>Network Status LEDs</b>	
<b>11-1</b>	<b>GPS</b>	<b>Blue</b> – GPS is ON. (Solid) Position is fixed. (Flashing) Position is not yet fixed.
<b>11-2</b>	<b>LAN 2</b>	<b>Blue</b> – LAN Port 2 is transmitting.
<b>11-3</b>	<b>Signal Strength</b>	<b>Blue</b> – Good signal strength <b>Green</b> – Normal signal strength <b>Red</b> – Poor signal strength or no signal
<b>11-4</b>	<b>Network Status</b>	<b>Blue</b> – LTE connection (Solid) Connection is established. (Flashing) Connection is not yet established. <b>Green</b> – 3G connection (Solid) Connection is established. (Flashing) Connection is not yet established. <b>Red</b> – No mobile internet connection
<b>11-5</b>	<b>LAN 1</b>	<b>Blue</b> – LAN Port 1 is transmitting.
<b>11-6</b>	<b>WiFi</b>	<b>Blue</b> – WiFi is ON.

---

# Installation

1. Mount the router with the four screws if needed.

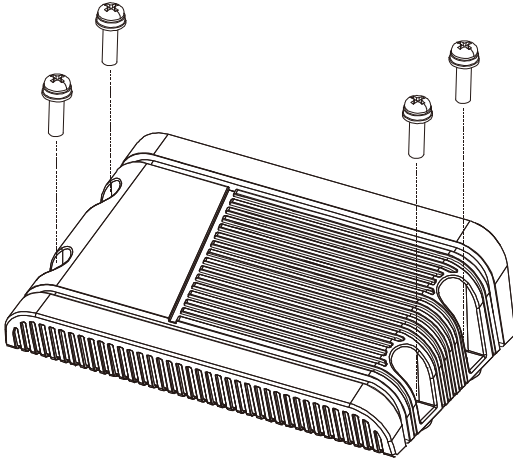

2. This router has its own internal SIM card. If you are using an external SIM card, load the SIM card as shown below:

- a) Choose the SIM card tray that matches your SIM card (Mini-SIM or Micro-SIM). Place the SIM card tray upside down. Secure the SIM card (contact side up) onto the SIM card tray.

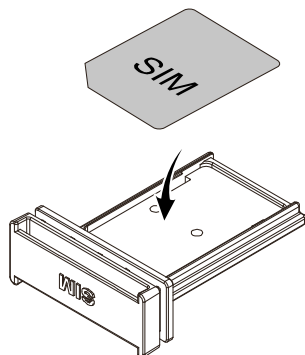

- b) Insert your loaded SIM card tray into the slot on the router.

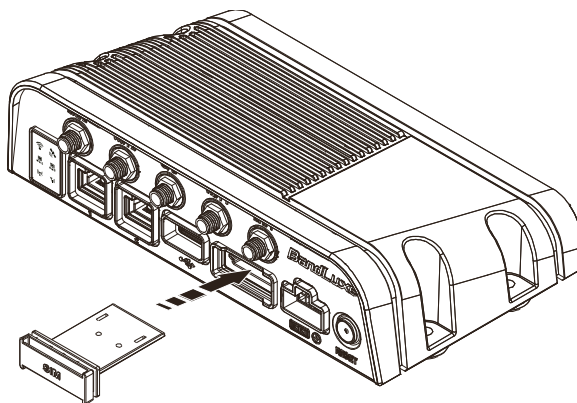

- 
3. Connect the power adapter cable to the router.

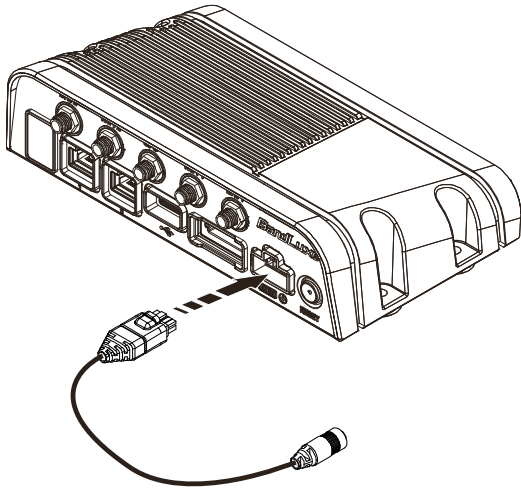

4. Connect the power adapter cable to either a power outlet (via the power adapter) or a 12VDC power source (including the optional automobile cigarette lighter power converter). The router will automatically be turned ON upon receiving power.

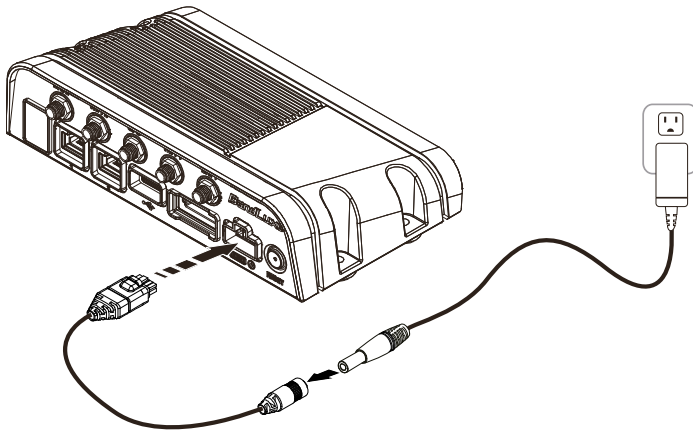

- 
5. (Optional) For any of the antenna connectors to be connected to this router, remove the corresponding protective cap and connect the GPS antenna, the WiFi antenna, or the LTE antenna.



6. To protect the connectors from water and dust intrusion, cover all unused connectors with their respective waterproof connector protective caps.

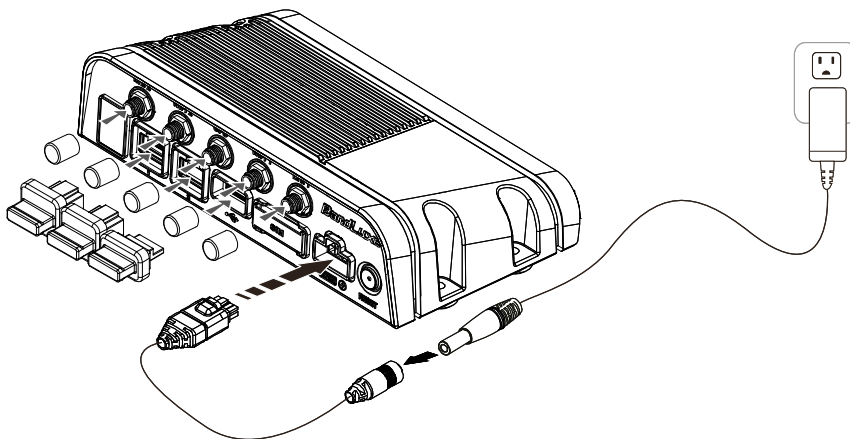

7. One of the following two methods can be chosen to link your PC with the router.

**A. Wireless Connection (for Windows)**

To link your PC to the router via WiFi, in Microsoft Windows, go to **Control Panel > Network Connections**. Right click on **Wireless Network Connection** and choose **View Available Wireless**

---

**Networks.** Select default SSID [**BR\_LTE\_xxxx**] and enter default password (please refer to the router's SSID/WPA sticker). The "xxxx" corresponds with the last 4 digits of MAC address. Click **Connect**.

Wireless Connection (for Mac)

Click the  on the upper side of the screen to view available wireless networks. Select default SSID [**BR\_LTE\_xxxx**] and enter default password (please refer to the router's SSID/WPA sticker). The "xxxx" corresponds with the last 4 digits of MAC address. Click **Join**.

**B. Wired Connection**

To connect your PC to the router via an Ethernet cable, connect one end of the cable to one of the four LAN ports on the router, and another end of the cable to an Ethernet port on your computer.

# Using Web-based Management

This chapter will guide you on how to configure your router via the web-based utility.

## Login

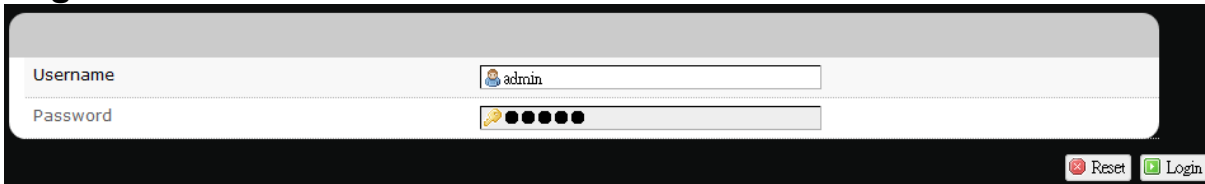

1. Launch a web browser (e.g Mozilla Firefox).
2. In the address bar, enter <http://192.168.1.1>, then press **Enter**.

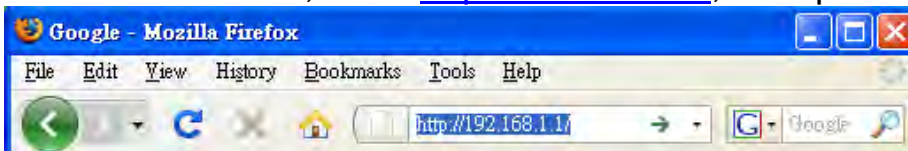

3. On the opening screen, enter the username (**admin**) and password (**admin**).
4. Click **Login** to login to the main screen.
5. Click one of the *menu*, *submenu*, and/or *setting* tabs to configure the system. Additionally, the *status area* displays current wireless network information and setting-related messages (e.g. the message **Unapplied Change** appears whenever new settings are temporarily stored in the router without being applied, which will remind you to click the  button).

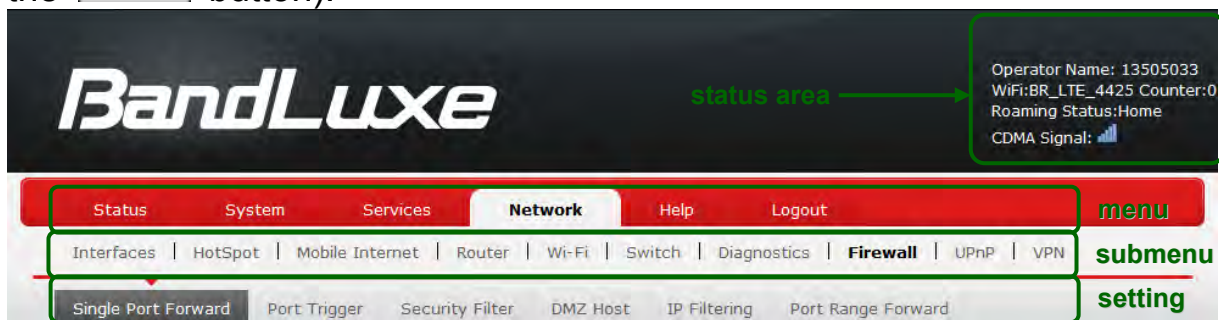

**Note:** If SIM Card's PIN verification is needed, select **Network > Mobile Internet > U/SIM PIN Management**. Enter the PIN code into text box of "**PIN Code Verification**". Click **Verify**. Mobile internet access will be enabled shortly after.

# Status

This menu displays various statuses of the router. The associated submenu items are: **Overview**, **System Log**, **GPS**, **VnStat Traffic Monitor**, and **Mobile Internet**.

## Overview

**Status** | System | Services | Network | Help | Logout

**Overview** | System Log | GPS | VnStat Traffic Monitor | Mobile Internet

### System

Router Model Name	K530S
Module Model Name	M530S
Router Firmware Version	AR_1_00000000_1_001_0047 SPRINT_3
Modem Firmware Version	00016739_0021
Module Manufacture:	BANDRICH INCORPORATED
Hardware Revision:	1.5
MIP profile NAI:	Not provisioned
Phone number (MDN):	0000000902
ICCID:	89011200000225390854
MIN (MSID):	0000000902
PRL version:	21096
IMEI	990001387003668
MEID	0099000138700366
Technology	CDMA ()
Local Time	Sun Sep 22 06:39:13 2013

### Network

IPv4 WAN Status	<i>Not connected</i>
IPv6 WAN Status	<i>Not connected</i>

### DHCP Leases

Hostname	IPv4-Address	MAC-Address	Leasetime remaining
User-NB2	192.168.1.194	20:89:84:85:1A:56	10h 58m 22s

### Local Network

Local MAC Address	Router IP Address	Subnet Mask	DHCP Server	DHCP Server Change	Start IP Address	IP Address Range
00:26:FA:0B:44:25	192.168.1.1	255.255.255.0	Enable	<a href="#">DHCP Server Change</a>	192.168.1.100	192.168.1.249

### Wireless

Generic 802.11bgn Wireless Controller (wifi0)	SSID: <a href="#">BR_LTE_4425</a> Channel: 9 (2.452 GHz) Mac address: 00:26:FA:0B:44:25 Encryption: mixed WPA/WPA2 PSK (CCMP)
---	--

### Associated Stations

MAC-Address	Network
<i>No information available</i>	

---

The **Overview** submenu renders complete statistics for the router.

## **System**

Displays system information: router model name, router model name, router firmware version, modem firmware version, mophone number (MDN), ICCID, MIN (MSID), PRL version, IMEI, MEID, and local time.

## **Network**

Displays current network connection information of IPv4 WAN and/or IPv6 WAN: type of network assignment (e.g. DHCP), network address, netmask, gateway, DNS addresses 1 & 2, and time connected since the establishment of the current mobile internet connection.

## **DHCP Leases**

Display DHCP lease information for each client: hostname, IPv4 address, MAC address, and lease time remaining.

## **Local Network**

Displays local network information: local MAC address, router IP address, subnet mask, DHCP server, DHCP server change, start IP address, IP and address range



# System Log

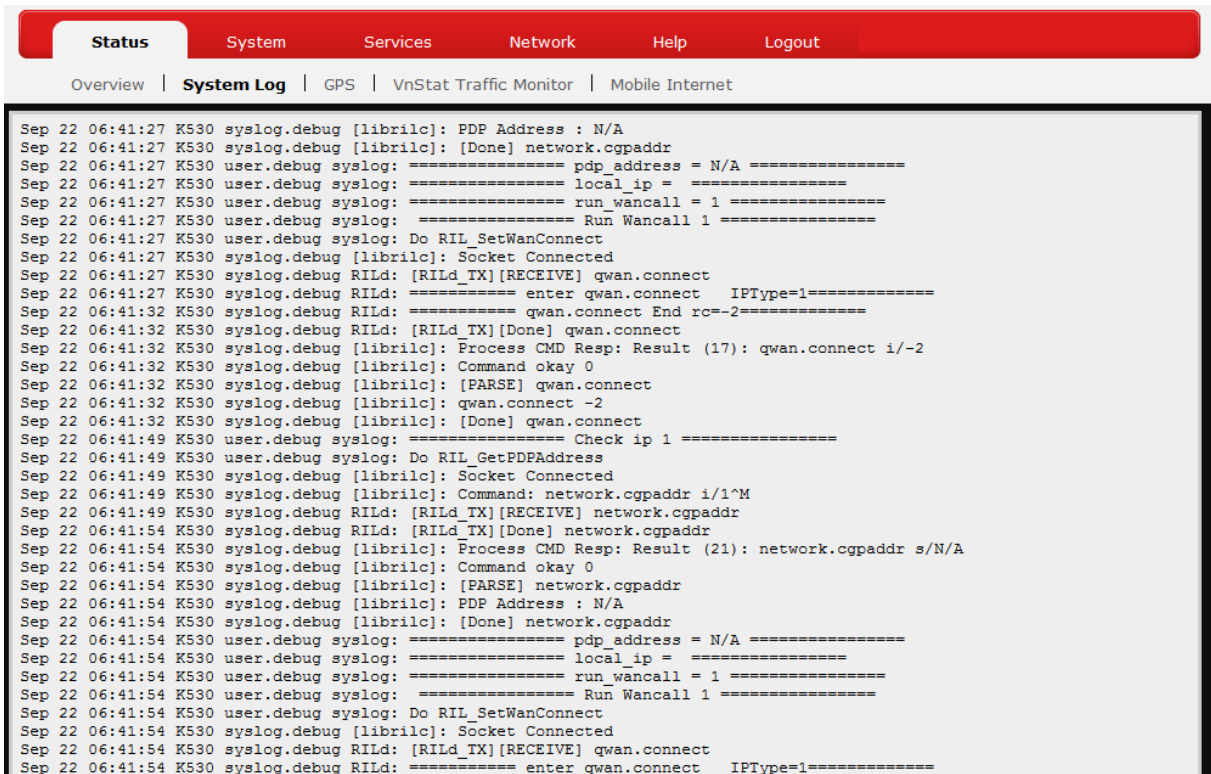

The **System Log** submenu tracks system activities after power on.

## GPS

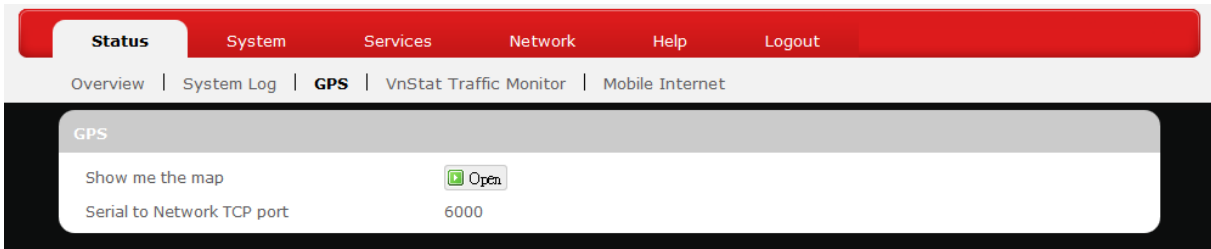

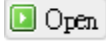
The **GPS** submenu displays Global Positioning System information. Click  to proceed.

## VnStat Traffic Monitor

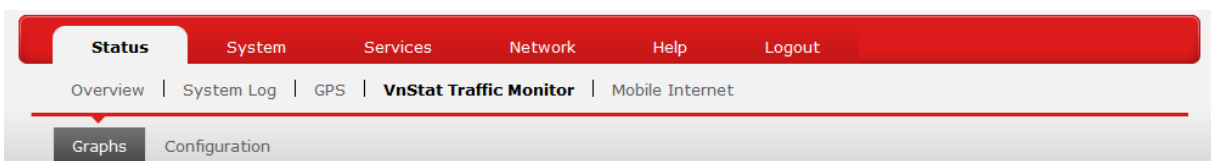

The **VnStat Traffic Monitor** submenu displays graphic analysis of the router's network traffic history.

## Graphs

Displays VnStat network traffic history in various graphic analysis options: **Summary display**, **Top 10 display**, **Hourly traffic**, **Daily traffic**, and **Monthly traffic**. Click , select an analysis option from the drop-down list, and click **Update**. The VnStat Graphs will be updated accordingly.

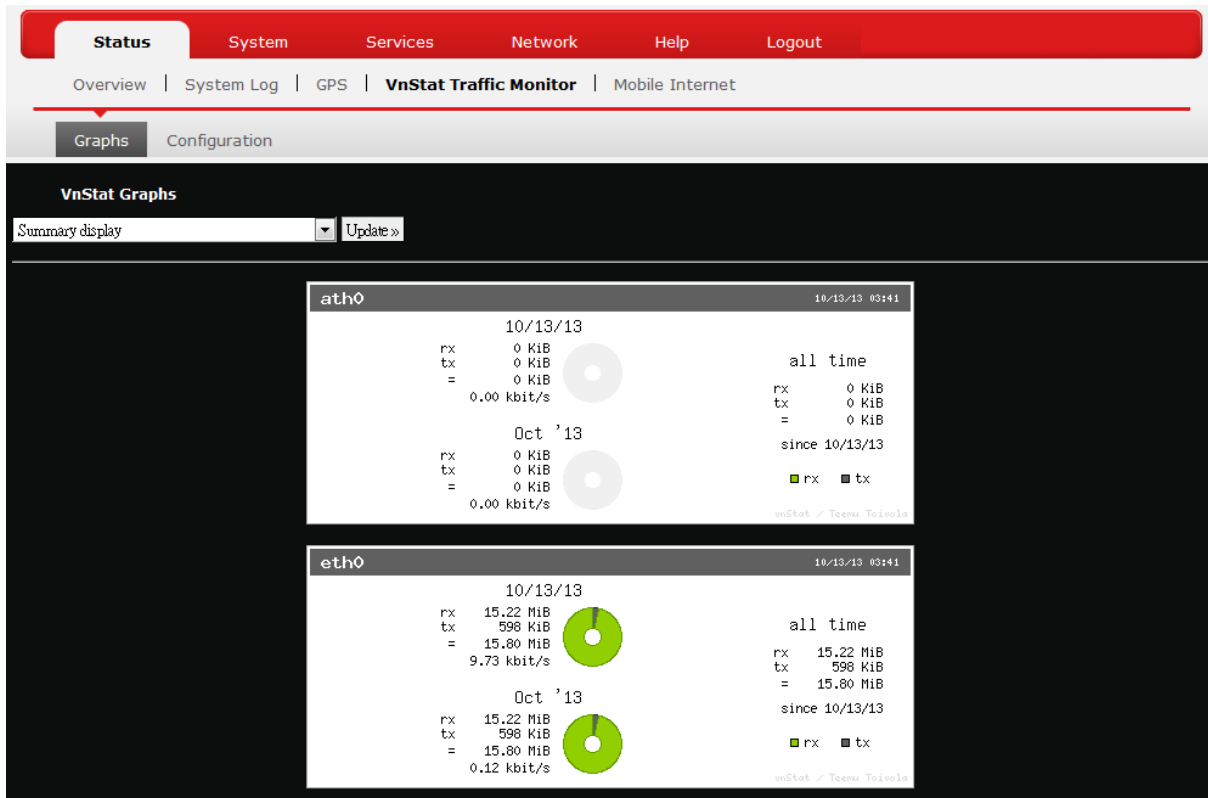

## Configuration

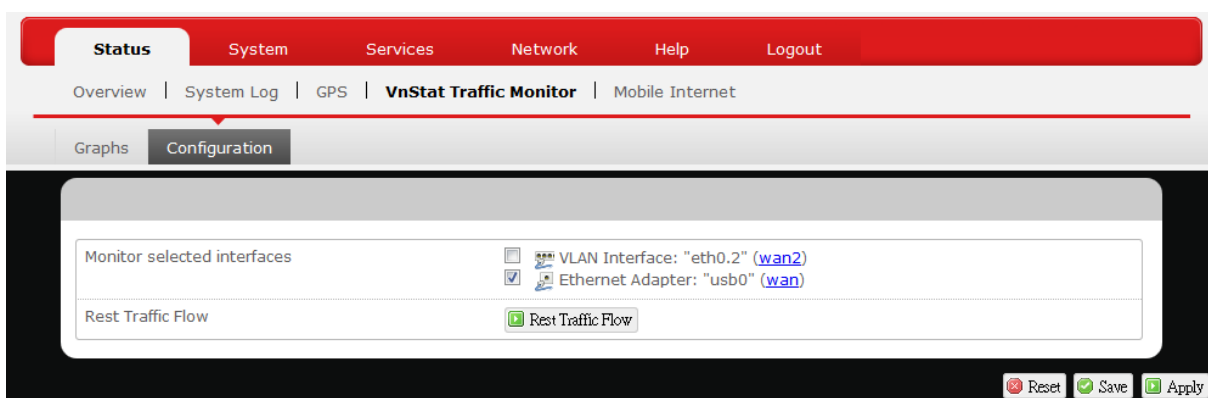

VnStat Traffic Monitor configurations can be made here.

a) *Monitor selected devices*: Click the checkbox to enable/disable network monitoring of the displayed interface(s). Click the link [wan](#) or [wan2](#) to jump to the associated **Common Configuration** setting under the submenu **Network** → **Interfaces**.

b) *Rest Traffic Flow*: Click to discard previous network history log and start anew.

## Mobile Internet

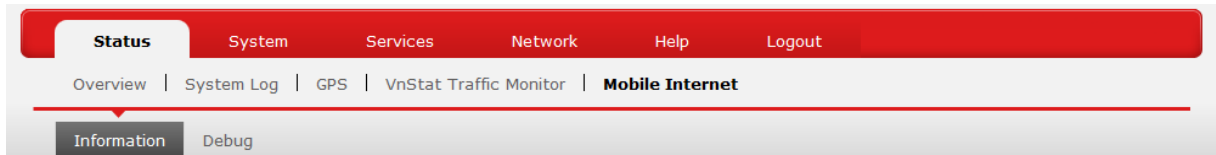

The **Mobile Internet** submenu displays mobile internet statistics along with a debug tool. It has two submenu settings: **Information** and **Debug**.

### Information

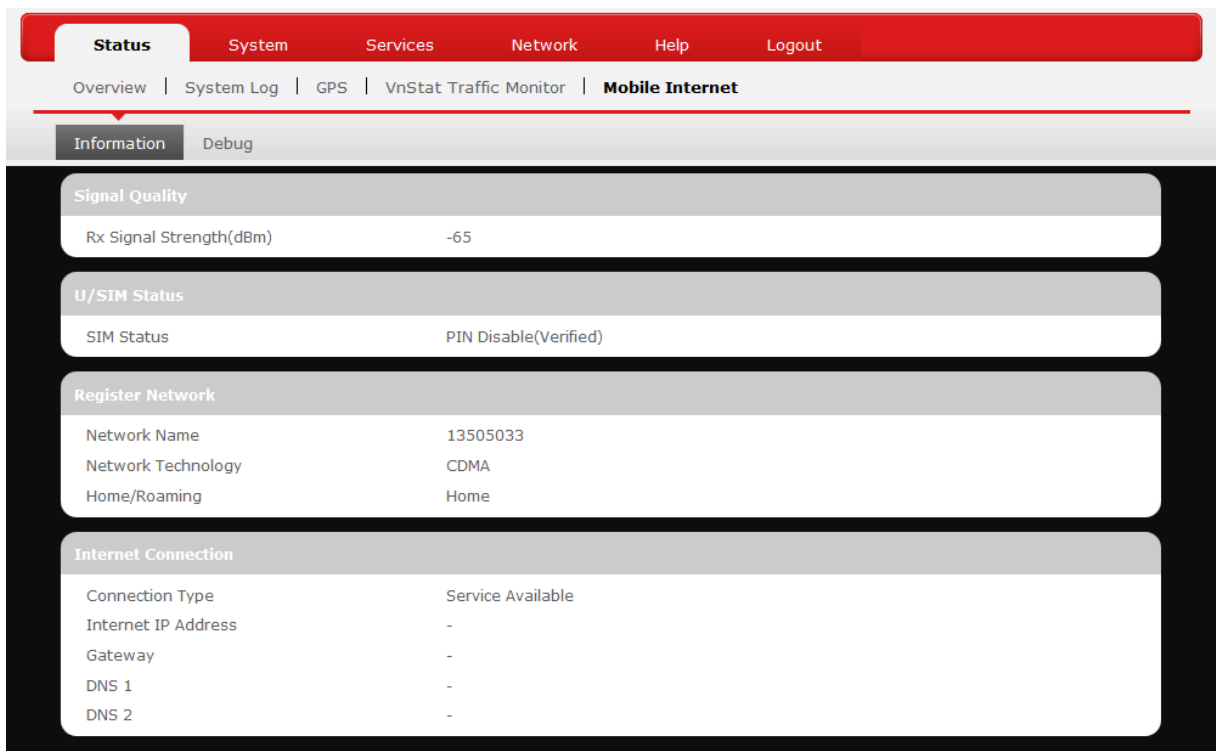

#### Signal Quality

Displays signal strength of current mobile internet connection in dBm.

#### U/SIM Status

Displays current SIM card status:

a) *Read SIM Fail* – No valid SIM card is inserted

b) *PIN Disable(Verified)* – PIN protection is disabled while the SIM card status is verified; mobile internet service is available with this status.

c) *PIN Enable(No Verified/Retries:#)* – PIN protection is enabled while the SIM card verification is pending (whereas # is the number of allowed PIN verifications remaining before SIM lock occurs).

d) *PIN Enable(Verified)* – PIN protection is enabled while the SIM card status is verified; mobile internet service is available with this status.

### **Registered Network**

a) *Network Name* – Name of your mobile internet service provider

b) *Network Technology* – Mobile internet communication signal type. Examples are WCDMA (3G) and LTE (4G).

c) *Home/Roaming* – Displays current network roaming status: Home indicates mobile internet connection to the home location where the SIM card service is registered. Roaming indicates the extended mobile internet connection service in a location different from the home location where the SIM card service is registered. An example of roaming is when you travel abroad.

### **Internet Connection**

Displays information of current internet connection: Connection Type, Internet IP Address, Gateway, and DNS 1/2.

### **Debug**

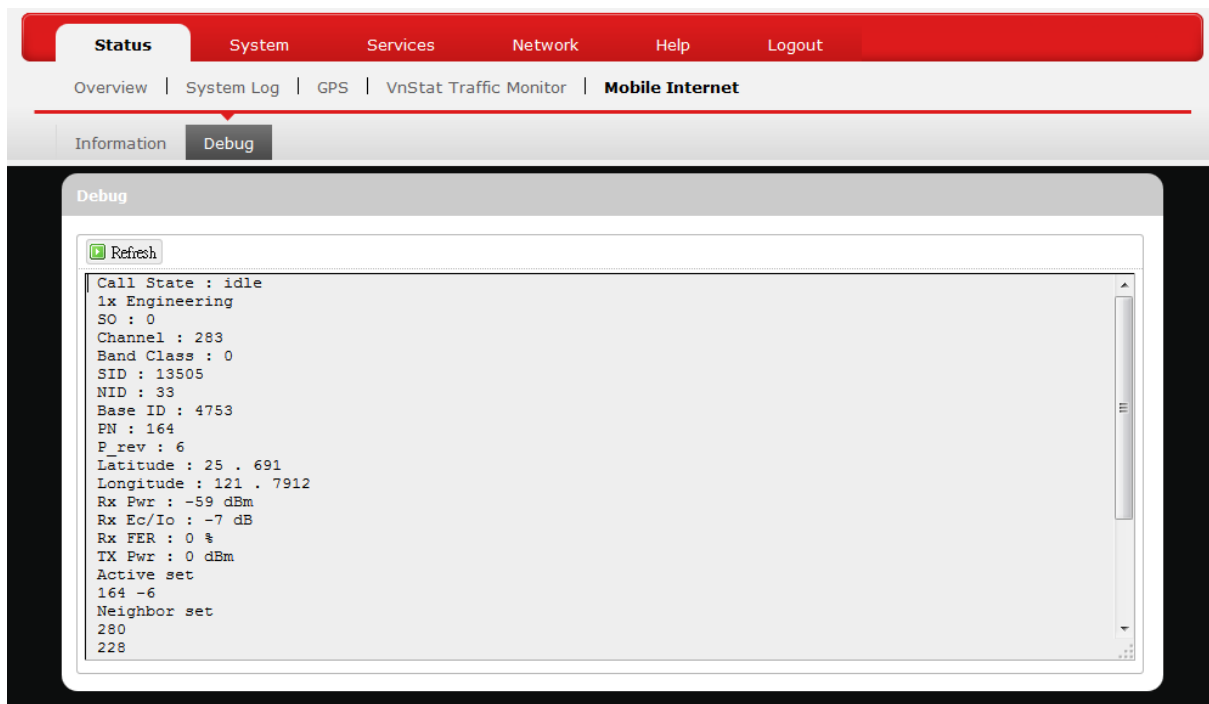

---

## ***Debug***

Displays mobile internet statistics for analysis and troubleshooting. Click  to update the statistics.

# System

This menu is for system information and configurations.

## System

The screenshot shows a web interface with a red navigation bar at the top containing 'Status', 'System', 'Services', 'Network', 'Help', and 'Logout'. Below the navigation bar is a breadcrumb trail: 'System | Administration | Backup / Flash Firmware | Reboot'. The main content area is titled 'System Properties' and contains three sections: 'General Settings', 'Time Synchronization', and 'Remote System Log'. The 'General Settings' section has two tabs: 'General Settings' (selected) and 'Language and Style'. It includes fields for 'Local Time' (Mon Sep 23 00:02:36 2013), 'Hostname' (K530), and 'Time Zone' (UTC). The 'Time Synchronization' section has a checked 'Enable NTP client' checkbox, an 'NTP server candidates 1' field (watch.stdtime.gov.tw), and an empty 'NTP server candidates 2' field. The 'Remote System Log' section has a 'Router LAN client IP Address' field and a 'Server port' field (514). At the bottom right, there are 'Reset', 'Save', and 'Apply' buttons.

## System Properties

Click either the “General Settings” or “Language and Style” tab to configure their respective settings.

### General Settings

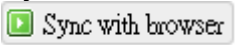
*Local Time* – Displays current local time. To synchronize local time with the browser, click .

*Hostname* – Enter the desired hostname in this check field.

*Time Zone* – Sets the time zone associated with this router. Click on  and select the desired region.

---

## Language and Style

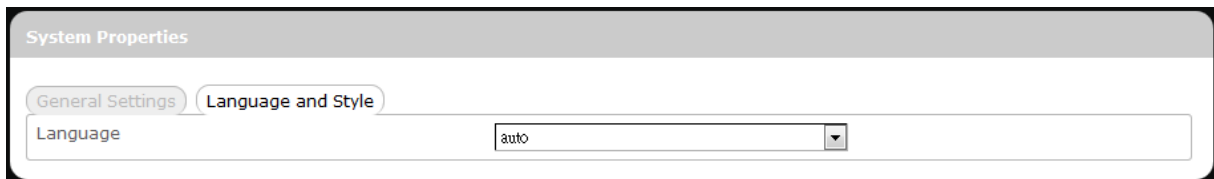

*Language* – Sets the desired display language and style of the router. Click  and select the desired display language and style.

## Time Synchronization

*Enable NTP client:* Click the checkbox to enable/disable. With this option enabled, two more options will appear– “Provide NTP server” and “NTP server candidates”.

*NTP server candidates 1/2:* Enter the desired server candidates here.

## Remote System Log

*Router LAN client IP address:* Displays the client IP address of the router LAN.

*Server port:* Displays port number of the server.

# Administration

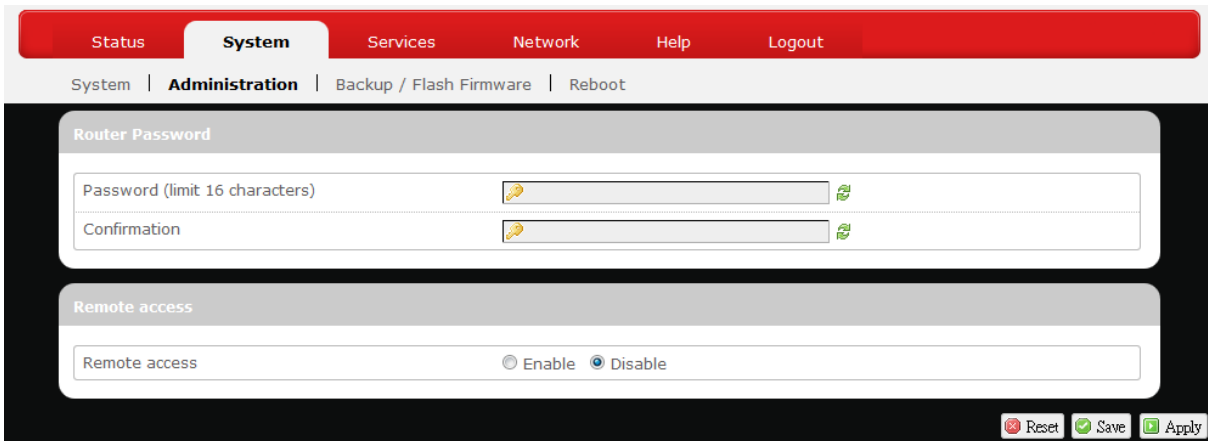

## Router Password

Login password of the router can be changed here. Enter the new password in the 'Password' field, and enter the same password once again in the 'Confirmation' field.

## Remote Access

This field specifies whether or not to allow remote access of this router.

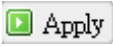
After changing password and/or specifying remote access, click  . The screen will display a confirmation message after successful password change.



# Backup / Flash Firmware

The screenshot shows a web interface for managing firmware. At the top, there is a navigation bar with tabs for Status, System (selected), Services, Network, Help, and Logout. Below this is a breadcrumb trail: System | Administration | Backup / Flash Firmware | Reboot.

The main content area is divided into several sections:

- Backup / Restore:** Contains instructions to click "Generate archive" for a tar archive and "Perform reset" for a factory reset. It has two rows of controls: "Download backup:" with a "Generate archive" button, and "Reset to defaults:" with a "Perform reset" button. Below this, it says "To restore configuration files, you can upload a previously generated backup archive here." and has a "Restore backup:" row with a "Browse..." button, "No file selected." text, and an "Upload archive..." button.
- Flash new firmware image:** Contains instructions to upload a sysupgrade-compatible image. It has a "Keep settings:" row with a checked checkbox and an "Image:" row with a "Browse..." button, "No file selected." text, and a "Flash image..." button.
- Flash new module firmware image:** Contains instructions to upload a module upgrade compatible image. It has an "Image:" row with a "Browse..." button, "No file selected." text, and a "Flash image..." button.
- Flash new ipkg package:** Contains instructions to upload a new ipkg. It has an "Image:" row with a "Browse..." button, "No file selected." text, and a "Flash image..." button.
- FOTA:** Contains settings for automatic updates. It has an "Auto check:" row with an unchecked checkbox, an "Update check period:" row with a text input containing "24" and "minute" text, and an "Apply" button. At the bottom, it has a "Check for firmware upgrade:" row with a "Check" button.

## Backup / Restore

### Download backup

Here you can backup all current settings of the router to a TAR archive file on your computer or mobile device. Just click . A dialog window will prompt you to open or save the archive file. Depending on the browser that you are using, the TAR file may be saved in the system download folder or a location of your choice.

---

## **Reset to defaults**

Here you can restore the router to its original factory settings. Just click , and a dialog message will appear to indicate the factory reset process. After completion of the reset process, the router will automatically reboot and return to its initial login prompt.

## **Restore backup**

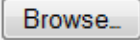
Here you can restore router settings previously saved as a TAR archive file on your computer or mobile device. Just click  to find and select the previously saved TAR archive file, and then click 'Open'.

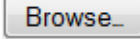
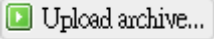
Confirm that the TAR filename appears beside the  button and click . The system will reboot after completion of backup restoration.

## **Flash new firmware image**

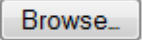
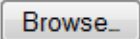
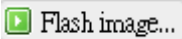
This option allows you to upgrade this router with the updated firmware image. Just click  to find and select the firmware image file, and then click 'Open'. Confirm that the firmware filename appears beside the  button and click . The system will reboot after successful upgrade.

## **Flash new module firmware image**

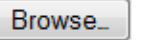
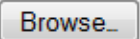
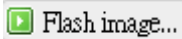
This option allows you to upgrade this router with the updated module firmware image. Just click  to find and select the firmware package file, and then click 'Open'. Confirm that the firmware filename appears beside the  button and click . The system will reboot after successful upgrade.

## **Flash new ipkg package**

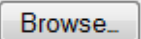
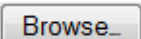
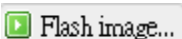
This option allows you to upgrade this router with the updated IPKG package. Just click  to find and select the IPKG package file, and then click 'Open'. Confirm that the IPKG package filename appears beside the  button and click . The system will reboot after successful upgrade.

## **FOTA**

This option (Firmware Over The Air) allows you to automatically or manually upgrade this router's firmware wirelessly.

---

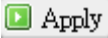
For automatic wireless update, enable “*Auto check*” and enter the desired time interval (in hours) between each check of the BandRich website for firmware update. For manual wireless update, disable “*Auto check*”. Click  to activate the wireless update configurations into effect.

To immediately check for firmware upgrade, click **Check**.



**Warning:** Upgrading firmware may take a few minutes; do not turn off the power or press the Reset button during upgrade.

## Reboot

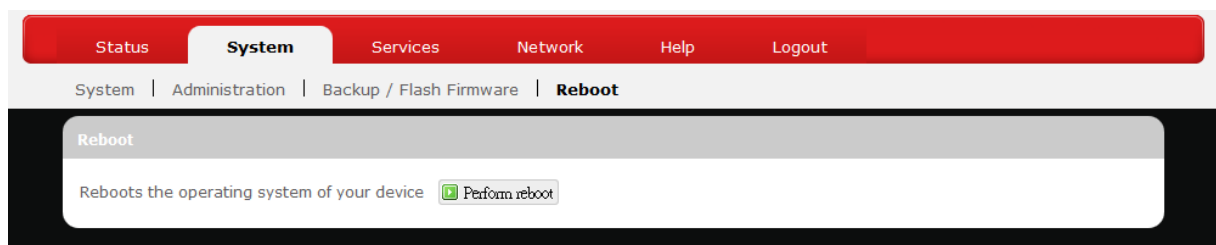

Click ‘Perform reboot’ to restart the router.

---

# Services

## Dynamic DNS

The screenshot shows a web interface with a red navigation bar at the top containing 'Status', 'System', 'Services', 'Network', 'Help', and 'Logout'. Below the navigation bar, the page title is 'Dynamic DNS | Network Shares'. The main content area is titled 'Dynamic DNS' and contains a configuration form for 'myddns'. The form has the following fields: 'Enable' (checkbox), 'Service' (drop-down menu with 'dyndns.org' selected), 'Hostname' (text input with 'mypersonaldomain.dyndns.org'), 'Username' (text input with 'myusername'), and 'Password' (password input with a strength indicator). At the bottom right of the form are three buttons: 'Reset', 'Save', and 'Apply'.

The **Services** menu hosts configuration options for **Dynamic Domain Name Service (DDNS)**, which is a system that allows the domain name data held in a name server to be updated in real time. It allows an Internet domain name to be assigned to a computer with a varying (dynamic) IP address. Before you can use this feature, you need to sign up for DDNS with a DDNS provider, [www.dyndns.org](http://www.dyndns.org) or [www.TZO.com](http://www.TZO.com).

**Enable:** Check or un-check this box to enable or disable DDNS.

**Service:** Specifies the DDNS service URL. From the drop-down list, click  and select an URL from the list.

**Hostname:** Enter the hostname for your DDNS account.

**Username:** Enter the username for your DDNS account.

**Password:** Enter the password for your DDNS account.

# Network Shares

The screenshot shows the 'Network Shares' configuration page. At the top, there is a red navigation bar with 'Status', 'System', 'Services', 'Network', 'Help', and 'Logout'. Below this, there are tabs for 'Dynamic DNS' and 'Network Shares'. The main content area is titled 'Samba' and contains two sections: 'General Settings' and 'Shared Directories'. The 'General Settings' section has fields for 'Hostname' (BLNet1), 'Description' (BLNet1), 'Workgroup' (WORKGROUP), and 'Share home-directories' (1). The 'Shared Directories' section is a table with columns: Name, Path, Allowed users, Read-only, Allow guest, Create mask, and Directory mask. It shows one entry: USB\_Storage, /mnt, bandrich, Read-only checked, Allow guest unchecked, Create mask 5, and Directory mask 5. There are 'Add', 'Delete', 'Reset', 'Save', and 'Apply' buttons at the bottom.

The **Network Shares** submenu hosts configuration options for sharing the USB storage drive on the network.

## Samba

This section is for detailed configurations of Samba server, which sets up this router as the USB storage drive server.

### General Settings

- Hostname: Specify host name to be seen on the network.
- Description: Specify description for the host.
- Workgroup: Specify workgroup name (e.g. WORKGROUP).
- Share home-directories: This option allows system users to reach their home directories via network sharing. The default value is 1.

## Edit template

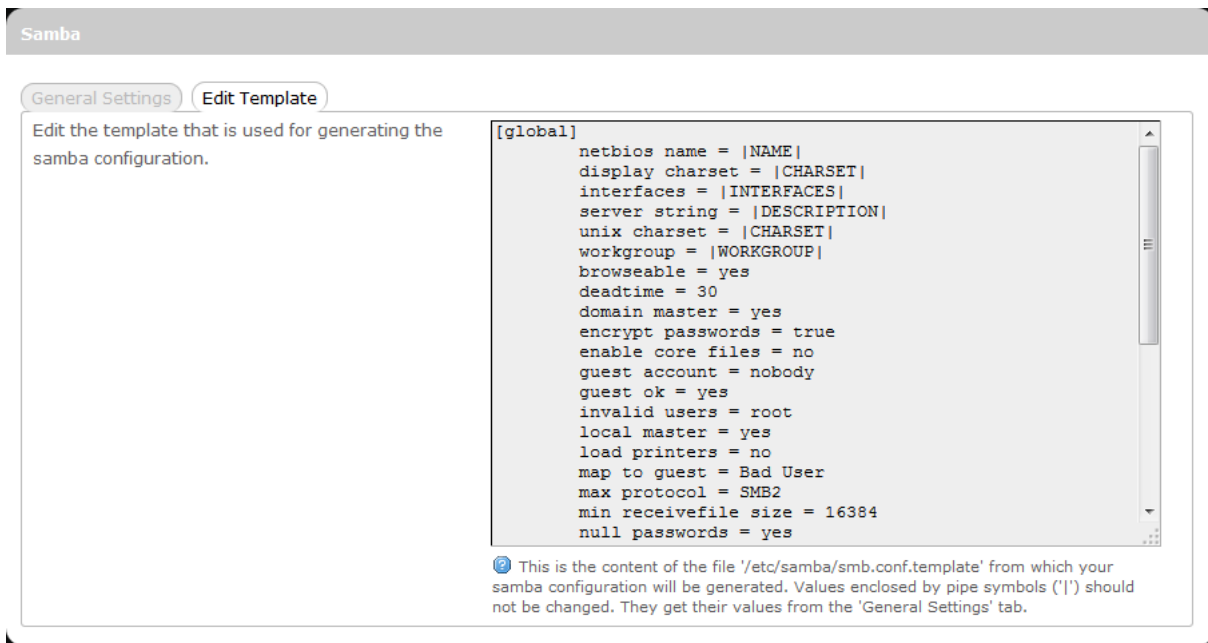

Samba

General Settings Edit Template

Edit the template that is used for generating the samba configuration.

```
[global]
netbios name = |NAME|
display charset = |CHARSET|
interfaces = |INTERFACES|
server string = |DESCRIPTION|
unix charset = |CHARSET|
workgroup = |WORKGROUP|
browseable = yes
deadtime = 30
domain master = yes
encrypt passwords = true
enable core files = no
guest account = nobody
guest ok = yes
invalid users = root
local master = yes
load printers = no
map to guest = Bad User
max protocol = SMB2
min receivefile size = 16384
null passwords = yes
```

© This is the content of the file '/etc/samba/smb.conf.template' from which your samba configuration will be generated. Values enclosed by pipe symbols ('|') should not be changed. They get their values from the 'General Settings' tab.

This section is for advanced users to edit the template used for generating Samba configuration.

## Shared Directories

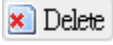
This section is for detailed configurations of shared directories. To add a directory for sharing, click . To remove a directory for sharing, click the corresponding  button. In the status area, the message **Unapplied Change** may appear next to “Operator Name” to indicate configuration changes temporarily stored in the router.

- |                                   |  |
|-----------------------------------|--|
| Name:                             | Specifies name of the shared directory.  |
| Path:                             | Specifies the complete path of the directory.  |
| Allowed users:                    | Specifies the samba users that will be allowed to access the shared directories.   |
| Read only:                        | Enables or disables the read-only option for the shared directory.   |
| Allow guests:                     | Enables or disables guest access for the shared directory.   |
| Create mask (Mask for new files): | Changes file access permissions according to the integer code entered. This field is equivalent to the <i>chmod</i> command of the Linux/Unix operating systems. |

Directory mask (Mask for new directories):

Changes directory access permissions according to the integer code entered. This field is equivalent to the *chmod* command of the Linux/Unix operating systems.

## Network

### Interfaces

The screenshot shows a web management interface with a red navigation bar at the top containing 'Status', 'System', 'Services', 'Network', 'Help', and 'Logout'. Below the navigation bar is a breadcrumb trail: 'Interfaces | HotSpot | Mobile Internet | Router | Wi-Fi | Switch | Diagnostics | Firewall | UPnP | VPN'. The main content area is titled 'Interface Overview' and displays a table of network interfaces.

Network	Status	Actions
<b>PPTP</b> pptp-pptp	RX: 0.00 B (0 Pkts.) TX: 0.00 B (0 Pkts.)	<a href="#">Edit</a>
<b>LAN</b> br-lan	Uptime: 4d 18h 0m 15s MAC-Address: 00:26:FA:0B:44:25 RX: 14.25 MB (104280 Pkts.) TX: 20.31 MB (72351 Pkts.) IPv4: 192.168.1.1/24	<a href="#">Edit</a>
<b>WAN</b> usb0	Uptime: 0h 0m 0s MAC-Address: 0A:88:FA:27:E1:C4 RX: 0.00 B (0 Pkts.) TX: 53.71 MB (136681 Pkts.)	<a href="#">Edit</a>
<b>WAN2</b> eth0.2	Uptime: 0h 0m 0s MAC-Address: 00:26:FA:0B:44:25 RX: 0.00 B (0 Pkts.) TX: 2.80 MB (7115 Pkts.)	<a href="#">Edit</a>

The **Interfaces** submenu allows interface configurations of different networks connected to this router. The configuration items are the same for each network with different default settings.

### Interface Overview

Here you can see the brief network status summary for PPTP (Point-to-Point Tunneling Protocol), LAN (local area network), WAN (wide area network), and WAN2 (wide area network 2). To configure LAN or WAN interfaces, click the appropriate **Edit** button and follow the below section *Common Configuration* for more details.

# Common Configuration

## General Setup

Common Configuration

General Setup | Advanced Settings | Physical Settings | Firewall Settings

Status

br-lan

Uptime: 4d 18h 17m 9s  
MAC-Address: 00:26:FA:0B:44:25  
RX: 15.14 MB (111136 Pkts.)  
TX: 21.35 MB (77211 Pkts.)  
IPv4: 192.168.1.1/24

Protocol: Static address

IPv4 address: 192.168.1.1

IPv4 netmask: 255.255.255.0

IPv4 gateway:

IPv4 broadcast:

Use custom DNS servers:

Accept router advertisements:

Send router solicitations:

IPv6 address:

IPv6 gateway:

**Status:** Displays protocol-dependent statistics of network connection.

**Protocol:** Specifies the protocol to be used for the network. The available protocols are *Static address*, *DHCP client*, *Unmanaged*, *PPP*, *PPtP*, *PPPoE*, *PPPoATM*, *UTMS/GPRS/EV-DO*, and *L2TP*. The default LAN protocol is *Static address*, whereas the default WAN protocol is *DHCP client*.

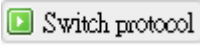
**Really switch protocol:** This configuration item appears when the protocol is changed. Press  to confirm protocol change and show protocol-dependent configuration items.

**(Protocol-dependent configuration items):** Different protocol-dependent configuration items will appear according to the protocol chosen.



## Advanced Settings

The screenshot shows the 'Common Configuration' window with the 'Advanced Settings' tab selected. The 'General Setup' sub-tab is active, displaying the following configuration items:

Bring up on boot	<input checked="" type="checkbox"/>
Override MAC address	00:26:FA:0B:44:25
Override MTU	1428
Use gateway metric	0

This tab is for advanced users to make detailed configurations of protocol-related settings. Actual configuration items will vary according to the protocol chosen in the tab item *General Setup*.

## Physical Settings

The screenshot shows the 'Common Configuration' window with the 'Physical Settings' tab selected. The 'Interface' section lists several options:

- Ethernet Switch: "eth0"
- VLAN Interface: "eth0.1" (lan)
- VLAN Interface: "eth0.2" (wan2)
- Ethernet Adapter: "usb0" (wan)
- Wireless Network: Master "BR\_LTE\_4425" (lan)
- Custom Interface:

This tab is for selection of physical interface of the associated network. Click one of the available physical interfaces or click Custom Interface: and enter your own interface name.

This tab is not available for the following protocols: *PPP*, *PPtP*, *PPPoE*, *PPPoATM*, *UTMS/GPRS/EV-DO*, and *L2TP*.

## Firewall Settings

The screenshot shows the 'Common Configuration' window with the 'Firewall Settings' tab selected. The 'Create / Assign firewall-zone' section displays the following options:

- lan: lan:
- wan: wan:
- wan2: wan2:
- unspecified -or- create:

Below the options, a note states: "Choose the firewall zone you want to assign to this interface. Select *unspecified* to remove the interface from the associated zone or fill out the *create* field to define a new zone and attach the interface to it."

This tab is for adjustment of firewall settings.

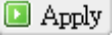
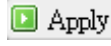
Click the desired network as the desired firewall zone assigned to this interface. Furthermore, you can remove the interface from the associated zone by entering “unspecified” in the *unspecified -or- create* field and clicking , or you can define a new zone by entering your own firewall name in the *unspecified -or- create* field and clicking .

## Hotspot

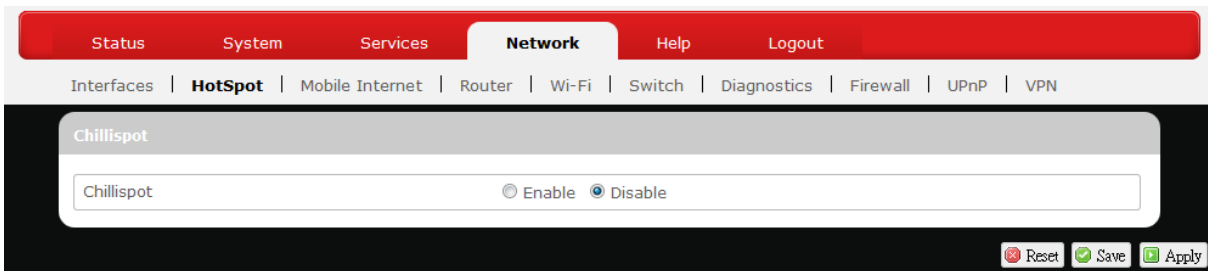

The **Hotspot** submenu is for setup and adjustment of mobile internet connection through WLAN (wireless local area network).

## Chillispot

Chillispot	
Chillispot	<input checked="" type="radio"/> Enable <input type="radio"/> Disable
Separate wifi from the LAN Bridge	<input checked="" type="radio"/> Enable <input type="radio"/> Disable
DHCP Interface	LAN
Remote Network	192.168.182.0/24
Primary Radius Server IP/DNS	rad01.chillispot.org
Backup Radius Server IP/DNS	rad02.chillispot.org
DNS IP	172.16.0.5
Redirect URL	
Share Key	testing123
Radius NAS ID	
UAM Secret	h2eb8ej5o4et3rg1ulp
UAM Allowed	
MACauth	<input type="radio"/> Enable <input checked="" type="radio"/> Disable
Additional Chillispot Option	

**Chillispot:** Enable or disable the chillispot (i.e. hotspot) feature.

**Separate WiFi from the LAN Bridge:** Enable or disable WiFi separation from the LAN bridge. If this option is enabled, two additional configuration items, *DHCP Interface* and *Remote Network*, will appear below.

- 
- DHCP Interface:** Select the appropriate DHCP interface when the configuration item “*WiFi separation from the LAN bridge*” is enabled. The options are *LAN*, *WAN*, or *WLAN&LAN*.
- Remote Network:** Enter the IP address of remote network when the configuration item “*WiFi separation from the LAN bridge*” is enabled.
- Primary RADIUS Server IP/DNS:** Enter the IP/DNS address of primary RADIUS server.
- Backup RADIUS Server IP/DNS:** Enter the IP/DNS address of backup RADIUS server.
- DNS IP:** Enter the numerical IP address of DNS.
- Redirect URL:** Enter the redirection URL if needed.
- Share key:** Enter the share key here.
- RADIUS NAS ID:** Enter the NAS ID for RADIUS authentication.
- UAM Secret:** Enter the secret code for UAM (universal access method).
- UAM Allowed:** Enter the name for UAM allowed.
- MACauth:** Enable or disables MAC authorization.
- Additional Chillispot Option:** Enter the additional chillispot option if needed.

## ***Mobile Internet***

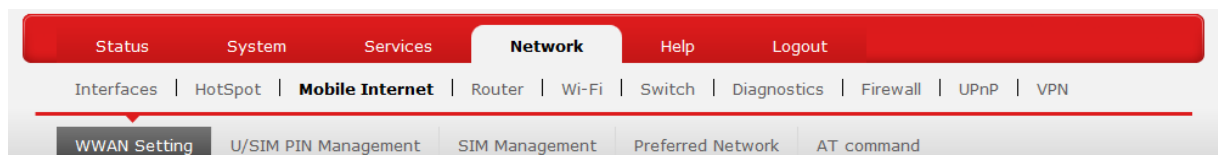

The **Mobile Internet** submenu is for setup and adjustment of mobile internet connection and furthermore has four setting tabs: **WWAN Setting**, **U/SIM PIN Management**, **SIM Management**, and **Preferred Network**.

# WWAN Setting

**Network Settings**

Roaming Connection: Roaming Connection is disabled  Enabled

Update Profile:   
This operation, also called CIDC (Client initiated Device Configuration) should only be performed when requested by support staff.

Update PRL:   
The PRL (Preferred Roaming List) is updated automatically. But you can perform a manual update if needed.

**Reset Modem**

MSL:

Reset Modem to defaults:

**Manually Update Phone Number**

MSL:

MDN:

**Manually Update MSID**

MSL:

MSID:

**Manually Update MIP Profile**

MSL:

NAI:

**eHRPD Menu**

eHRPD: eHRPD is enable now  Disable

**LTE Menu**

Enable LTE: LTE is enable now  Disable

## Network Settings

**Roaming** Enables or disables current roaming setting.

---

Connection:

Update Profile: Click **Update** to update the network profile.

Update PRL: Click **Update** to update the PRL (Preferred Roaming List).

### ***Reset Modem***

Enter the *MSL* (Maximum Segment Lifetime) when needed.

Click **Perform reset** to reset this router to its factory default settings.

### ***Manually Update Phone Number***

To update the mobile device phone number, , enter the *MSL* and *MDN* (Mobile Directory Number) as needed, then click **Update**.

### ***Manually Update MSID***

To update the *MSID* (Mobile Station Identification), enter the *MSL* and *MSID* as needed, then click **Update**.

### ***Manually Update MIP Profile***

To update the *MIP* (Mobile Internet Protocol) profile, enter the *MSL* and *NAI* (Network Access Identifier) as needed, then click **Update**.

### ***eHRPD Menu***

Click the appropriate button to enable or disable eHRPD (Evolved High Rate Packet Data) Menu.

### ***Enable LTE***

Click the appropriate button to enable or disable 4G LTE connection.

# U/SIM PIN Management

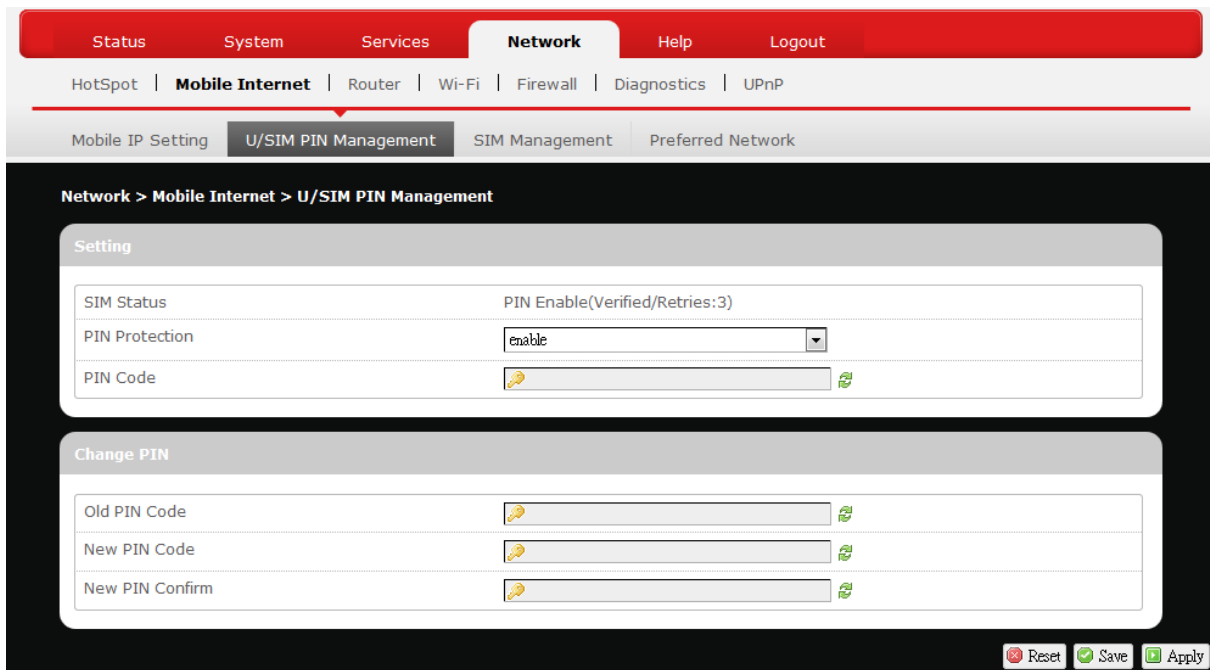

This submenu features configurable items that are dependent on the router’s mobile internet status, as detailed below.

## **Scenario 1: No mobile internet service**

Without a valid SIM card inserted into the router, the Verify dialog will show the following SIM card status:

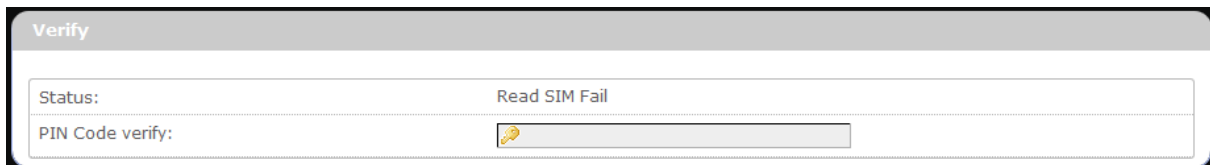

Here the Verify dialog shows SIM status as “Read SIM Fail”, meaning that no valid SIM card is inserted.

## **Scenario 2: Mobile internet service pending**

If a valid SIM card is inserted into the router requiring PIN code verification, the Verify dialog will show the following SIM card status:

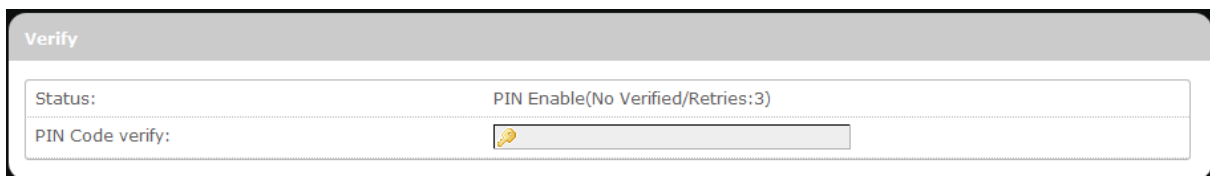

Here the Verify dialog shows the SIM status as “No Verified/Retries:3”, meaning that a valid SIM card is inserted with PIN code verification pending. Enter your SIM card verification code in the text box of “PIN

Code verify:”, and then click . Once the PIN code verification is finished, the router is ready to use the SIM card’s associated mobile internet access, and the top right status area will be updated accordingly.

Operator Name: 13505033  
WiFi:BR\_LTE\_4425 Counter:0  
Roaming Status:Home  
CDMA Signal: 



Operator Name: 13505033  
WiFi:BR\_LTE\_4425 Counter:0  
Roaming Status:Home  
CDMA Signal: 

Operator Name: Displays the name of the internet service provider

WiFi: Shows the active WiFi SSID of this router

Counter: Shows number of clients currently connected to the active SSID

Roaming Status: Displays current roaming status

(Carrier) Signal: Displays strength of the indicated signal type (Carrier)  
For example:

1. Without mobile internet connection, the display will be  (no signal).

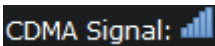
2. If CDMA (3G) mobile internet connection is established, the display will be  (CDMA carrier, excellent signal strength).

### **Scenario 3: Mobile internet service enabled**

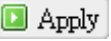
If a valid SIM card is inserted into the router with PIN code verified, the configuration dialog will be ‘Setting’ and/or “Change PIN” to allow further SIM card management (click  after making changes):

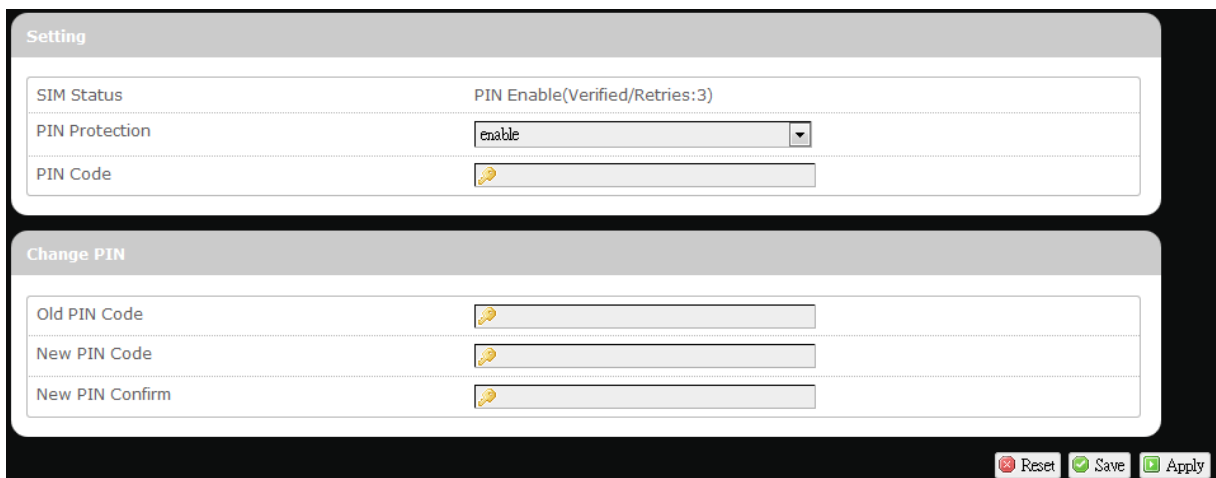

The screenshot shows a web-based configuration interface for a router. It is divided into two main sections: 'Setting' and 'Change PIN'.  
The 'Setting' section contains three rows:  
1. 'SIM Status' with a value of 'PIN Enable(Verified/Retries:3)'.  
2. 'PIN Protection' with a dropdown menu set to 'enable'.  
3. 'PIN Code' with a text input field containing a yellow key icon.  
The 'Change PIN' section contains three rows:  
1. 'Old PIN Code' with a text input field containing a yellow key icon.  
2. 'New PIN Code' with a text input field containing a yellow key icon.  
3. 'New PIN Confirm' with a text input field containing a yellow key icon.  
At the bottom right of the interface, there are three buttons: 'Reset' (with a red 'x' icon), 'Save' (with a green checkmark icon), and 'Apply' (with a green checkmark icon).

---

## **Setting**

- SIM Status: Shows current SIM card status.  
“*PIN Enable*” means that the SIM card is enabled for mobile internet access.  
“*PIN Disable(Verified/Retries:#)*” means that the SIM card is enabled for mobile internet access without requiring PIN code verification. Note that if PIN protection is re-enabled, # is the number of allowed PIN verifications remaining before SIM lock occurs.
- PIN Protection: Enables or disables the PIN protection by clicking  and making the appropriate choice from the drop-down list.
- PIN Code If PIN protection is enabled, you need to enter PIN code in this text box for making changes in this ‘Setting’ dialog.

## **Change PIN**

This option is configurable only if PIN Protection is enabled.

Here you can change the PIN code for enhanced SIM card security.

- Old PIN Code: Enter the old PIN code.
- New PIN code: Enter the new PIN code.
- New PIN code confirm: Enter the same new PIN code again for PIN code confirmation.

Click  after making changes in ‘Setting’ and/or “Change PIN”.



## SIM Management

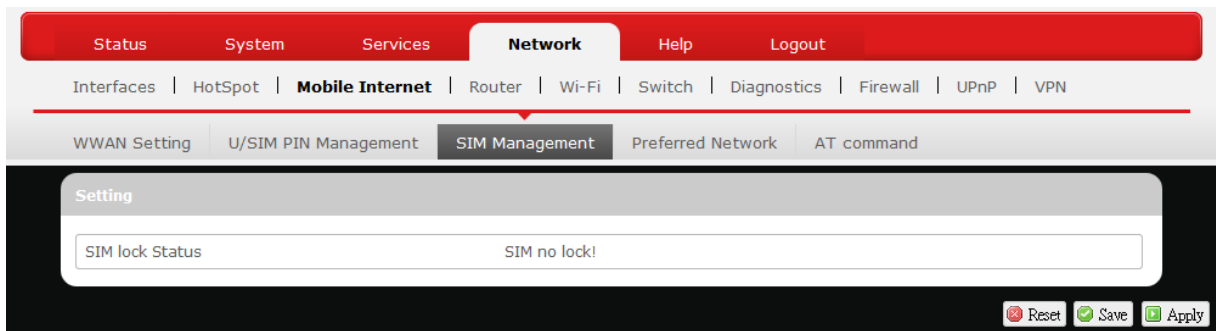

The screenshot shows the 'SIM Management' page in a web interface. The top navigation bar includes 'Status', 'System', 'Services', 'Network' (selected), 'Help', and 'Logout'. Below this, there are sub-menus for 'Interfaces', 'HotSpot', 'Mobile Internet' (selected), 'Router', 'Wi-Fi', 'Switch', 'Diagnostics', 'Firewall', 'UPnP', and 'VPN'. The main content area has tabs for 'WWAN Setting', 'U/SIM PIN Management', 'SIM Management' (selected), 'Preferred Network', and 'AT command'. The 'Setting' section displays 'SIM lock Status' as 'SIM no lock!'. At the bottom right, there are buttons for 'Reset', 'Save', and 'Apply'.

Here you can see the current SIM lock status.

### Scenario 1: SIM lock absent

“SIM no lock” means that the SIM card is unlocked.

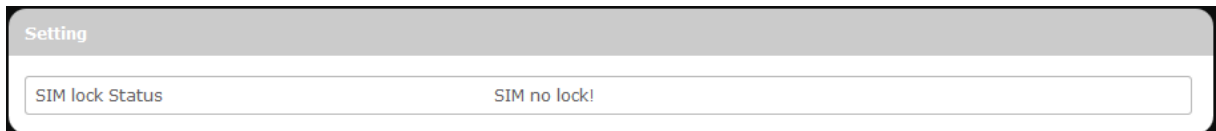

This screenshot is a close-up of the 'SIM lock Status' field, which displays the text 'SIM no lock!'.

### Scenario 2: SIM lock present

If your SIM card is locked for some reason, here you can also enter the SIM unlock code to unlock it. After entering the SIM unlock code in the text box “SIM Unlock”, click .

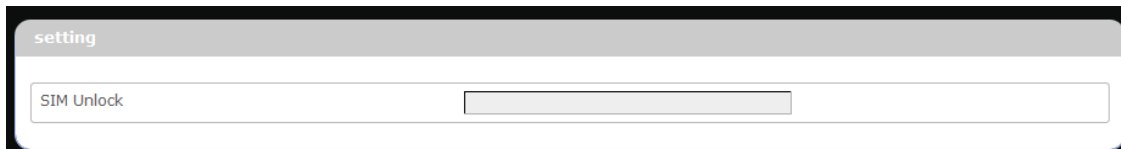

This screenshot shows the 'SIM Unlock' text box, which is currently empty.

## Preferred Network

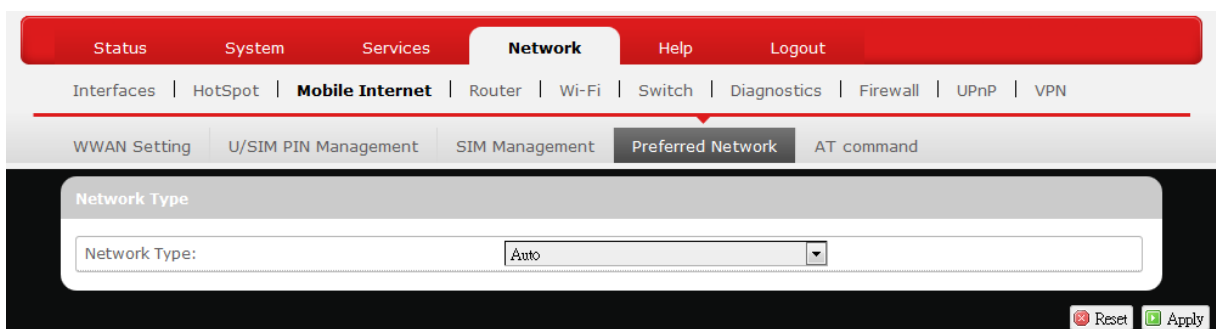

The screenshot shows the 'Preferred Network' page. The top navigation bar is the same as in the SIM Management page. The sub-menus include 'WWAN Setting', 'U/SIM PIN Management', 'SIM Management', 'Preferred Network' (selected), and 'AT command'. The 'Network Type' section features a dropdown menu currently set to 'Auto'. At the bottom right, there are buttons for 'Reset' and 'Apply'.

Here you can select the preferred mobile network type by clicking  and making a choice from the drop-down list. The default choice is *Auto*. Other available choice examples are *LTE (4G)*, *CDMA (3G)*, and *EVDO*.

# AT command

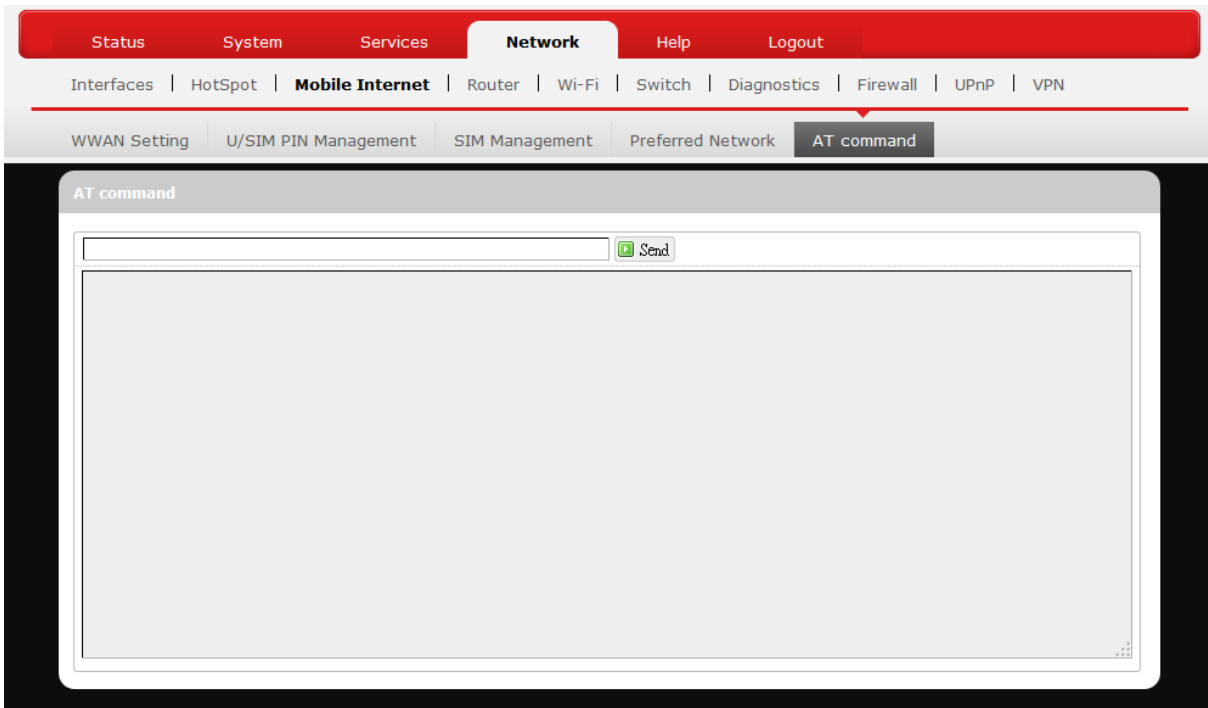

This section is for advanced users to control this router with the *AT command set* (also known as *Hayes command set*). Enter each command in the text box and click .

## Router

### Router Settings

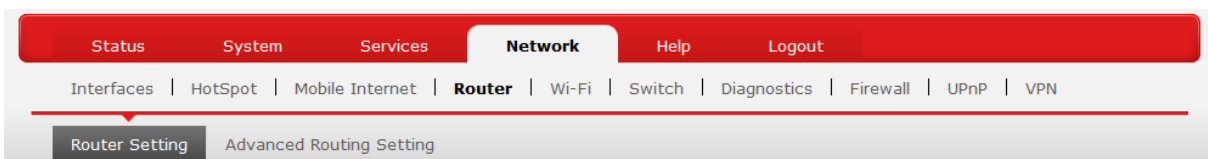

### Router IP

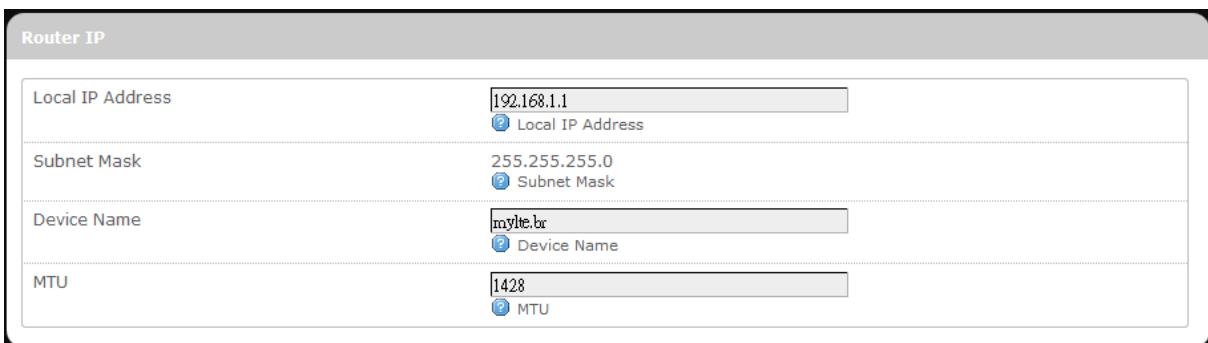

- Local IP Address:** The default local IP address of this router is 192.168.1.1. If this address conflicts with another local network device, you can enter another local IP address here.
- Subnet Mask:** Displays current Subnet Mask
- Device Name:** The current device name is displayed in gray color. The device name can be changed by typing in the new device name in this text box.
- MTU:** The current MTU (maximum transmission unit with default value of 1500 bytes) is displayed in gray color. The MTU can be changed by typing in the new MTU value in this text box.

### **DHCP Service**

- DHCP Server:** Enables or disables the DHCP Server feature.
- Start IP Address:** Specifies the starting number of the last 3 digits of assigned client IP address. For example, the default value of **100** means that the first assigned client IP address will be 192.168.1.**100**; the next assigned client IP address will be 192.168.1.**101**; and so on...
- Maximum Number of Users:** Specifies maximum number of users for this router. The default setting is 150 users.
- Client Lease Time:** Specifies the amount of lease time allocated to clients of this router, i.e. the expiry time of leased addresses.

Use 'h' to indicate hours or use 'm' to indicate minutes.

- IP Address Range:** Displays assignable local IP address range of this router
- Primary DNS:** If needed, specify the primary Domain Name System here.
- Secondary DNS:** If needed, specify the secondary Domain Name System here.

### Active DHCP Leases

Active DHCP Leases			
Hostname	IPv4-Address	MAC-Address	Leasetime remaining
User-NB2	192.168.1.194	20:89:84:85:1A:56	9h 22m 35s

This section displays active DHCP lease information for each client: **Hostname**, **IPv4 address**, **MAC address**, and **Lease time remaining**.



### Static Leases

Static Leases

Static leases are used to assign fixed IP addresses and symbolic hostnames to DHCP clients. They are also required for non-dynamic interface configurations where only hosts with a corresponding lease are served. Use the *Add* Button to add a new lease entry. The *MAC-Address* identifies the host, the *IPv4-Address* specifies to the fixed address to use and the *Hostname* is assigned as symbolic name to the requesting host.

Hostname	MAC-Address	IPv4-Address
This section contains no values yet		

 Add

  

This option allows fixed IP address and symbolic hostname assignments for DHCP clients.

To add a static lease, first click .

Static Leases

Static leases are used to assign fixed IP addresses and symbolic hostnames to DHCP clients. They are also required for non-dynamic interface configurations where only hosts with a corresponding lease are served. Use the *Add* Button to add a new lease entry. The *MAC-Address* identifies the host, the *IPv4-Address* specifies to the fixed address to use and the *Hostname* is assigned as symbolic name to the requesting host.

Hostname	MAC-Address	IPv4-Address	
<input type="text" value="BLStaticLease1"/>	<input type="text" value="20:89:84:85:1A:56"/>	<input type="text" value="192.168.1.194"/>	

 Add

Enter the desired hostname. Choose the desired MAC address and IPv4-Address (click  and select a rule from the drop-down list; if "--Custom--" is selected, the drop-down list will change to a text box to

allow you to enter your custom address).

The MAC address is for host identification, whereas the IPv4 address specifies the fixed address for static lease.

To remove any unwanted static lease, just click the corresponding  button.

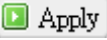
Click  after making any changes.

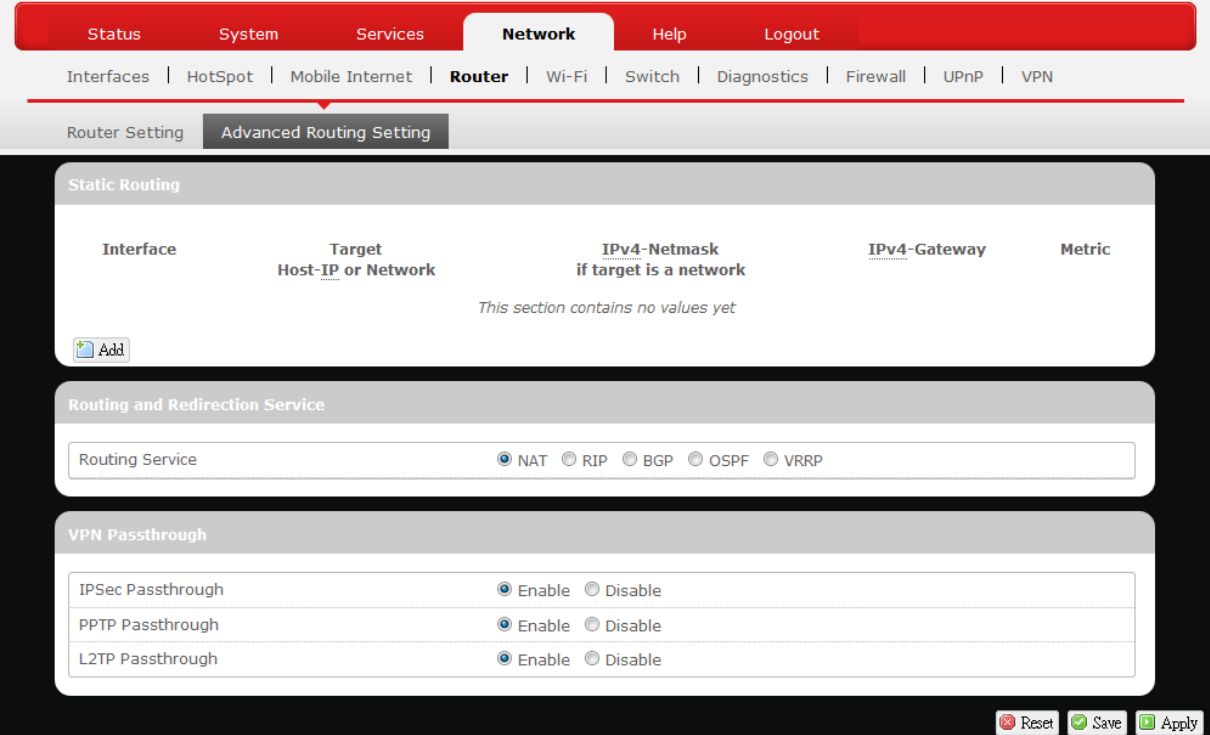

## Advanced Routing settings



The screenshot shows the 'Advanced Routing Setting' page. At the top, there is a navigation bar with 'Status', 'System', 'Services', 'Network', 'Help', and 'Logout'. Below this is a sub-menu with 'Interfaces', 'HotSpot', 'Mobile Internet', 'Router', 'Wi-Fi', 'Switch', 'Diagnostics', 'Firewall', 'UPnP', and 'VPN'. The 'Router Setting' section is active, and 'Advanced Routing Setting' is selected. The main content area is divided into three sections: 'Static Routing', 'Routing and Redirection Service', and 'VPN Passthrough'. The 'Static Routing' section has a table with columns: 'Interface', 'Target Host-IP or Network', 'IPv4-Netmask if target is a network', 'IPv4-Gateway', and 'Metric'. Below the table is an 'Add' button. The 'Routing and Redirection Service' section has a 'Routing Service' dropdown and radio buttons for 'NAT', 'RIP', 'BGP', 'OSPF', and 'VRRP'. The 'VPN Passthrough' section has three rows: 'IPSec Passthrough', 'PPTP Passthrough', and 'L2TP Passthrough', each with 'Enable' and 'Disable' radio buttons. At the bottom right, there are 'Reset', 'Save', and 'Apply' buttons.

### Static Routing

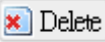

This option allows fixed network routing path assignment (as opposed to the initial adaptive routing).

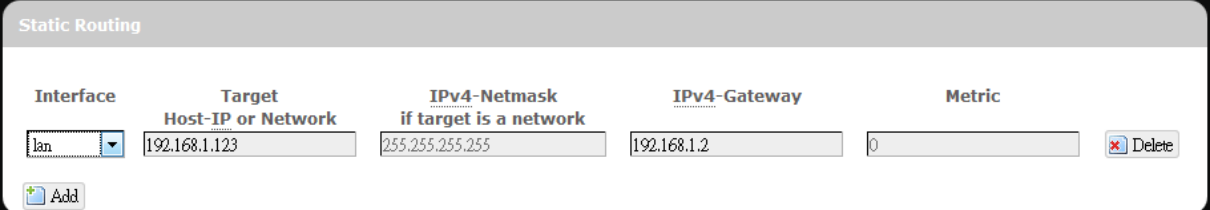
To add a static network routing path, click . To remove any unwanted static network routing path, click the corresponding  button. Click  after making any changes.



The screenshot shows the 'Static Routing' section with a table containing one entry. The table has columns: 'Interface', 'Target Host-IP or Network', 'IPv4-Netmask if target is a network', 'IPv4-Gateway', and 'Metric'. The entry is: Interface: lan, Target: 192.168.1.123, IPv4-Netmask: 255.255.255.255, IPv4-Gateway: 192.168.1.2, Metric: 0. There is a 'Delete' button next to the entry and an 'Add' button below the table.

- 
- Interface:** Click  and choose 'lan' (local area network), 'wan' (wide area network), or 'wan2' (wide area network 2).
- Target:** Enter the target host IP or network address here.
- IPv4-Netmask:** Displays the IPv4-Netmask address (the default is 255.255.255.255). A custom IPv4-Netmask can also be specified here.
- IPv4-Gateway:** If needed, a custom IPv4-Gateway address can be specified here.
- Metric:** Specifies the network path priority number (usually associated with the network path's administrative distance). The lower the metric number, the higher priority of this static route in the network routing protocol.  
The default value is 0 (highest priority). A different metric number can also be specified here.

**Note:** If contents in the text box is invalid, a  will appear on the right side of the text box, and the text color changes to red. For example, the following demonstrates an invalid target Host-IP or Network address:  

### ***Routing and Redirection Service***

This option enables or disables Network Address Translation (NAT) service, which is a standard that allows multiple computers on a private network to share a single IP address.

### ***VPN Passthrough***

A Virtual Private Network (VPN) is a type of secured private network connection, built upon publicly-accessible infrastructure such as the Internet. They usually provide connectivity to various devices behind a gateway or firewall.

**IPSec Passthrough:** IP Security (IPSec) provides authentication and encryption. Since it is mainly a Layer 3 technology, it can secure all data on the network. To allow IPSec tunnels to pass through the Router, click 'Enabled'.

**PPTP** Point-to-Point Tunneling Protocol (PPTP) allows you

Passthrough: to establish a connection to an enterprise network. To allow PPTP tunnels to pass through the Router, click Enabled.

L2TP Passthrough: Layer 2 Tunneling Protocol (L2TP) is an extension of the Point-to-Point Tunneling Protocol and is also used to establish virtual private networks. To allow L2TP tunnels to pass through the Router, click Enabled.

## WiFi

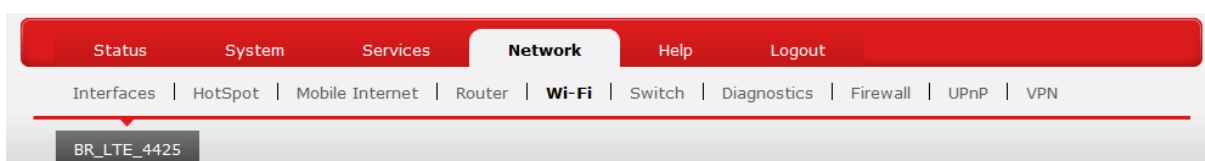

This submenu item is for configuring all Wi-Fi-related settings. This router initially has the default WiFi SSID. The default SSID and password are as follows:

Tab Name	Corresponding SSID	Default Password
"BR_LTE_xxxx"	BR_LTE_xxxx	Please refer to your K530's SSID/WPA sticker for the default password.

### Note:

- "xxxx" refers to the last four digits of this router's MAC address. For example, if the router's MAC address is 0026FA0B314A, then its corresponding SSID is BR\_LTE\_314A.
- Initially this router has only the default SSID enabled. The *Dual SSID* feature can be enabled in the [Advanced Settings](#) tab under the setting [Device Configuration](#).

Please click  after making any changes in this submenu.

## Device Configuration

### General Setup

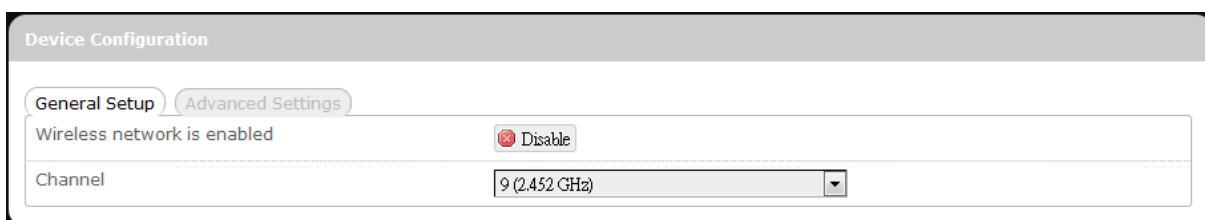

or



Wireless network is enabled\*:

WiFi connection of the associated SSID is enabled.

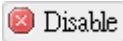
To disable WiFi connection of this SSID, click .

Wireless network is disabled\*:

WiFi connection of the associated SSID is disabled.

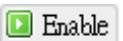
To enable WiFi connection of this SSID, click .

\* Note: The associated SSID is displayed either in the selected submenu tab under WiFi or in the WiFi category item **Interface Configuration → General Setup → SSID**.

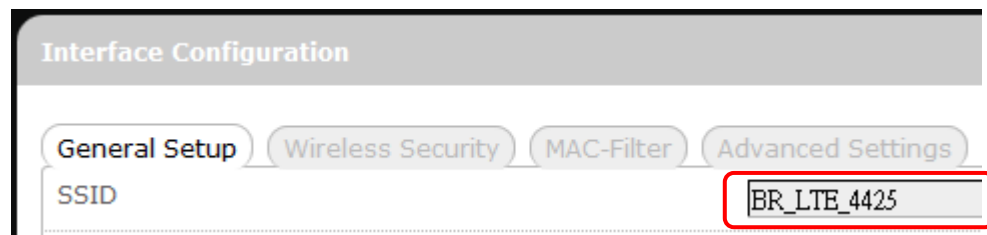

Channel:

Selects the WiFi channel for communication. The available choices are:

Channel (carrier frequency)

- 1 (2.412 GHz)
- 2 (2.417 GHz)
- 3 (2.422 GHz)
- 4 (2.427 GHz)
- 5 (2.432 GHz)
- 6 (2.437 GHz)
- 7 (2.442 GHz)
- 8 (2.447 GHz)
- 9 (2.452 GHz)
- 10 (2.457 GHz)
- 11 (2.462 GHz)

auto

← assigns channel automatically

-- custom --

← manually specifies WiFi channel

Normally one of the channels is already selected, and no change is needed unless there exists interference problems



with other WiFi or Bluetooth devices (that also use the 2.4GHz frequency range for communications). Alternatively, you can select 'auto' to let the system select the channel automatically, or you can select "-- custom --" and enter your own channel specification in the text box.

## Advanced Settings

Device Configuration

General Setup | **Advanced Settings**

Mode: Auto

HT mode: 20MHz

Dual SSID is disabled:  Enable

- Mode** Specifies the IEEE wireless standard for WiFi communication. The choices are:
- Auto: (Default choice) The router automatically chooses the optimal IEEE wireless standard.
  - 802.11b: Data speed up to 11 Mbps
  - 802.11g: Data speed up to 54 Mbps
  - 802.11n: Data speed up to 300 Mbps
- HT mode** Specifies channel width for data communications. The choices are:
- 20MHz: Single 20MHz channel
  - 20MHz / 40MHz: Single or dual 20MHz channels
- Dual SSID is disabled/enabled** Click  Enable to activate the second SSID, or click  Disable to deactivate the second SSID.

## Interface Configuration

### General Setup

Interface Configuration

General Setup | **Wireless Security** | MAC-Filter | Advanced Settings

SSID: BR\_LTE\_4425

Mode: ap

Hide SSID:

SSID	Service Set Identification To change the SSID, click the text box and enter the new SSID (up to 32 alphanumeric characters)
Mode	Wireless operating mode of this router. AP:        Wireless Access Point
Hide SSID	Enable this option to make wireless network of <i>this</i> SSID unavailable to nearby WiFi clients. Disable this option to make wireless network of <i>this</i> SSID available to nearby WiFi clients (default setting).

 **CAUTION:** To enable “Hide SSID”, we strongly advise you to do so via wired LAN connection, since wireless LAN connection with this SSID will be lost with this option applied! If both SSIDs are hidden, then the communications with this router must be done via a LAN port, or this router must be reset to factory default settings.

## Wireless Security

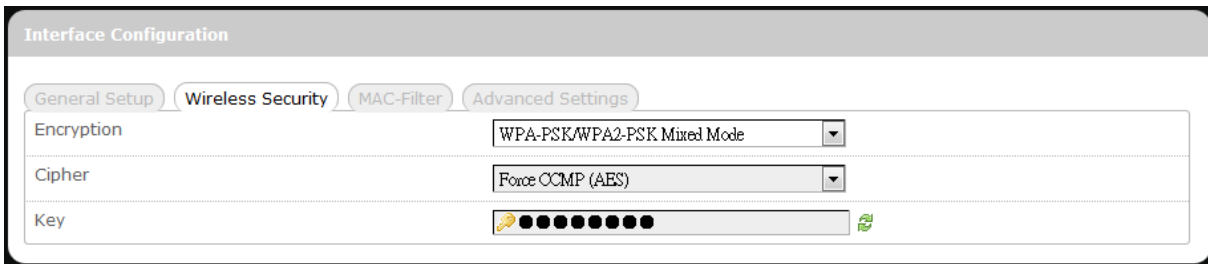

This router supports wireless data encryption, a must for wireless data security. The Wireless Security Interface Configuration items will change according to the chosen encryption method.

The encryption options are:

### 1. No Encryption

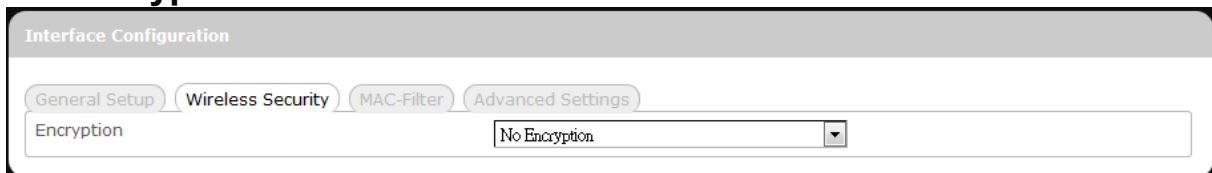

Data transmitted over wireless networks can be seen by others.

### 2. WEP Open System

Wired Equivalent Privacy encryption with Open System authentication

Interface Configuration

General Setup | **Wireless Security** | MAC-Filter | Advanced Settings

Encryption: WEP Open System

Key: [password icon]

Key: Enter a password for accessing this SSID's wireless network.

### 3. WPA-PSK

“WiFi Protected Access – Pre-Shared Key” encryption

Interface Configuration

General Setup | **Wireless Security** | MAC-Filter | Advanced Settings

Encryption: WPA-PSK

Cipher: Force CCMP (AES)

Key: [password icon]

Cipher: Specify the desired encryption protocol by clicking  and selecting an option from the drop-down list:

*auto* – (default setting) the system automatically chooses the optimal encryption protocol

*Force CCMP (AES)* – Use CCMP (AES) encryption exclusively (stronger than TKIP)

*Force TKIP* – Use TKIP encryption exclusively

*Force TKIP and CCMP (AES)* – Use TKIP and CCMP (AES) encryption protocols together

Key: Enter a password for accessing this SSID's wireless network.

### 4. WPA2-PSK

“WiFi Protected Access II – Pre-Shared Key” encryption

Interface Configuration

General Setup | **Wireless Security** | MAC-Filter | Advanced Settings

Encryption: WPA2-PSK

Cipher: Force CCMP (AES)

Key: [password icon]

Cipher: Specifies the desired encryption protocol by clicking  and selecting an option from the drop-down list:

*auto* – (Default setting) the system automatically chooses the optimal encryption protocol

---

*Force CCMP (AES)* – Use CCMP (AES) encryption exclusively (stronger than TKIP)

*Force TKIP* – Use TKIP encryption exclusively

*Force TKIP and CCMP (AES)* – Use TKIP and CCMP (AES) encryption protocols together

Key: Enter a password for accessing this SSID's wireless network.

## 5. WPA-PSK/WPA2-PSK Mixed Mode

“WiFi Protected Access I + II – Pre-Shared Key” encryption

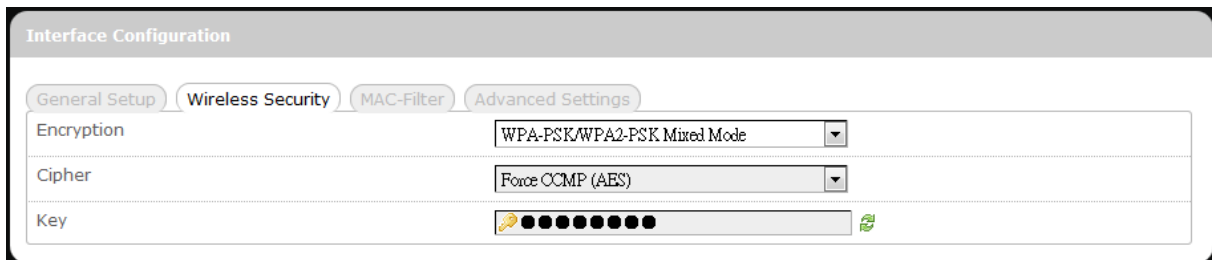

The screenshot shows the 'Interface Configuration' window with the 'Wireless Security' tab selected. It features three sub-tabs: 'General Setup', 'Wireless Security', and 'Advanced Settings'. Under 'Wireless Security', there are three rows: 'Encryption' with a dropdown menu set to 'WPA-PSK/WPA2-PSK Mixed Mode', 'Cipher' with a dropdown menu set to 'Force CCMP (AES)', and 'Key' with a text input field containing 12 black dots and a green lock icon on the right.

Cipher: Specifies the desired encryption protocol by clicking  and selecting an option from the drop-down list:

*auto* – (Default setting) the system automatically chooses the optimal encryption protocol

*Force CCMP (AES)* – Use CCMP (AES) encryption exclusively (stronger than TKIP)

*Force TKIP* – Use TKIP encryption exclusively

*Force TKIP and CCMP (AES)* – Use TKIP and CCMP (AES) encryption protocols together

Key: Enter a password for accessing this SSID's wireless network.

## 6. WPA-EAP

“WiFi Protected Access – Extensible Authentication Protocol” encryption

The screenshot shows the 'Interface Configuration' window with the 'Wireless Security' tab selected. The 'Cipher' dropdown menu is open, showing 'Force CCMP (AES)' as the selected option. Other fields include 'Encryption' set to 'WPA-EAP', 'Radius-Authentication-Server' (empty), 'Radius-Authentication-Port' set to 'Default 1812', and 'Radius-Authentication-Secret' (empty with a password icon).

**Cipher:** Specifies the desired encryption protocol by clicking  and selecting an option from the drop-down list:

*auto* – (default setting) the system automatically chooses the optimal encryption protocol

*Force CCMP (AES)* – Use CCMP (AES) encryption exclusively (stronger than TKIP)

*Force TKIP* – Use TKIP encryption exclusively

*Force TKIP and CCMP (AES)* – Use TKIP and CCMP (AES) encryption protocols together

**Radius-Authentication-Server:** Enter the name of the RADIUS authentication server.

**Radius-Authentication-Port:** Enter the port number of the RADIUS authentication port (the default port number is 1812).

**Radius-Authentication-Secret:** Enter the desired RADIUS secret password.

## 7. WPA2-EAP

“WiFi Protected Access II – Extensible Authentication Protocol” encryption

The screenshot shows the 'Interface Configuration' window with the 'Wireless Security' tab selected. The 'Cipher' dropdown menu is open, showing 'Force CCMP (AES)' as the selected option. Other fields include 'Encryption' set to 'WPA2-EAP', 'Radius-Authentication-Server' (empty), 'Radius-Authentication-Port' set to 'Default 1812', and 'Radius-Authentication-Secret' (empty with a password icon).

**Cipher:** Specifies the desired encryption protocol by clicking  and selecting an option from the drop-down list:

---

*auto* – (default setting) the system automatically chooses the optimal encryption protocol

*Force CCMP (AES)* – Use CCMP (AES) encryption exclusively (stronger than TKIP)

*Force TKIP* – Use TKIP encryption exclusively

*Force TKIP and CCMP (AES)* – Use TKIP and CCMP (AES) encryption protocols together

Radius-Authentication-Server: Enter the name of the RADIUS authentication server.

Radius-Authentication-Port: Enter the port number of the RADIUS authentication port (the default port number is 1812).



Radius-Authentication-Secret: Enter the desired RADIUS secret password.

## **MAC-Filter**

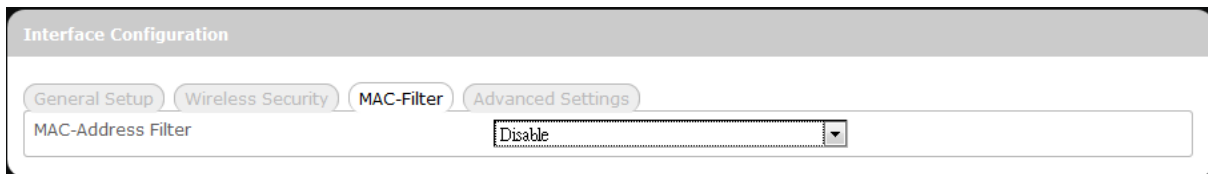
MAC-Address Filter:



This tab item allows you to selectively allow or block clients from network access. Click  and select an option from the drop-down list:

1. Disable – The MAC address filter is disabled (default option).
  2. White list\* – Click  and select a desired MAC address from the drop-down list, or select "-- custom --" and enter a specific client's MAC address.
  3. Black list\* – Click  and select an undesired MAC address from the drop-down list, or select "-- custom --" and enter a specific client's MAC address.
- \* To add another MAC address to the list, click  to add a new drop-down list; then repeat the MAC address selection/specification. To remove a MAC address from the list, click .

---

## Advanced Settings

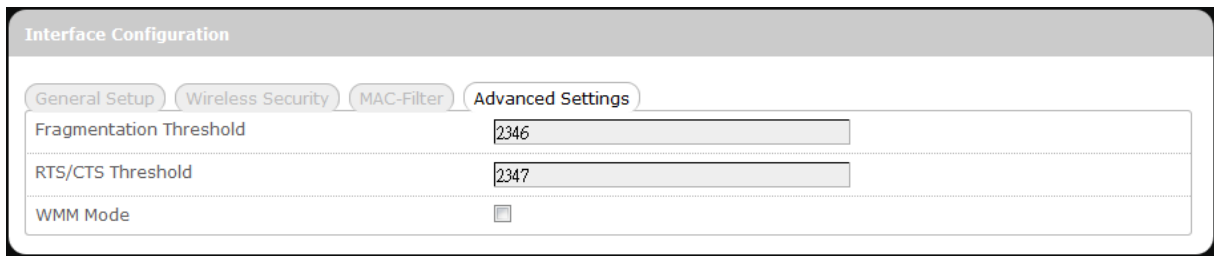

Interface Configuration

General Setup Wireless Security MAC-Filter **Advanced Settings**

Fragmentation Threshold	2346
RTS/CTS Threshold	2347
WMM Mode	<input type="checkbox"/>

This tab item is for advanced adjustment settings for WiFi connection.

- |                          |  |
|--------------------------|--|
| Fragmentation Threshold: | Maximum transmittable data packet frame size without frame fragmentation; the default value is 2346  |
| RTS/CTS Threshold:       | Defines Request-To-Send (transmitter) and Clear-To-Send (receiver) control packet size; the default value is 2347  |
| WMM Mode:                | Enables or disables Wi-Fi Multimedia Mode, which gives multimedia data contents (voice, video, and audio) higher priority over wireless networks. The default setting of WMM Mode is Disabled. |

# Switch

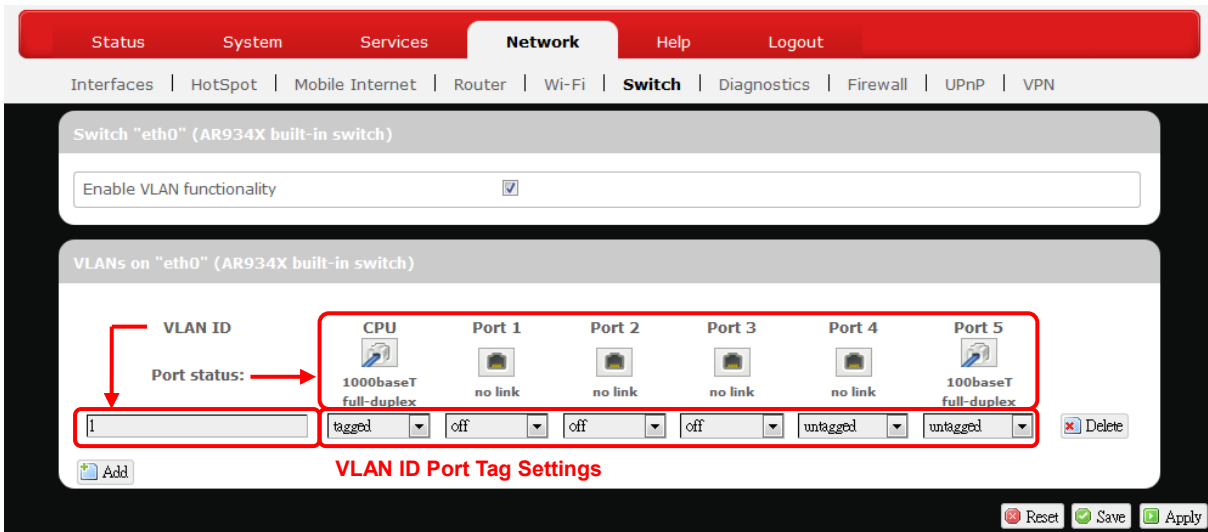

This submenu is for advanced users to view and configure this router's VLAN (Virtual Local Area Network) status and tag settings. The use of different VLAN IDs, each with its own tag settings for each logical network port, allows the router's network to be partitioned into different virtual networks (up to 4095).

## Switch "eth0" (AR934X built-in switch)

**Enable VLAN functionality:** Here you can enable or disable the VLAN feature.

## VLAN on "eth0" (AR934X built-in switch)

**VLAN ID:** Enter the desired VLAN Identification Number here (1-4094). Different VLAN IDs have different roles and functions. Click **Add** to set up another VLAN ID and its tag settings, or click **Delete** to remove a particular VLAN ID.

**0:** (Default VLAN) Reserved for tagging priority of data packets. This VLAN ID is not available for the user.

**1-511:** Reserved for normal VLANs.

**512-4094:** Reserved for VLAN *circuit cross-connect* (CCCs).



---

Port status: Displays the name, the symbolic icon, and the connection status for each of the logical network ports (here we have six of them: *CPU* and *Port 1-5*). The connection status for each logical network port is defined as follows:

no link: No network connection is established.

1000baseT full-duplex: Network connection is established at 1000 Mbps.

1000baseT full-duplex: Network connection is established at 100 Mbps.

VLAN ID Port Tag Settings: This row of settings allows you to define the tagging status for each logical network port within a particular VLAN ID.

Off Each *packet* flowing through the associated network port does not belong to *this* VLAN ID.

Untagged: Each *packet* flowing through the associated network port belongs to the default VLAN ID (VLAN 0).

Tagged: Each *packet* (sometimes known as *Ethernet frame*) flowing through the associated network port belongs specifically to *this* VLAN ID.

To make changes in this submenu effective, click .

**Note:** A *packet* is an unit of network data and is sometimes known as an *Ethernet frame* or a *frame*.

## Diagnostics

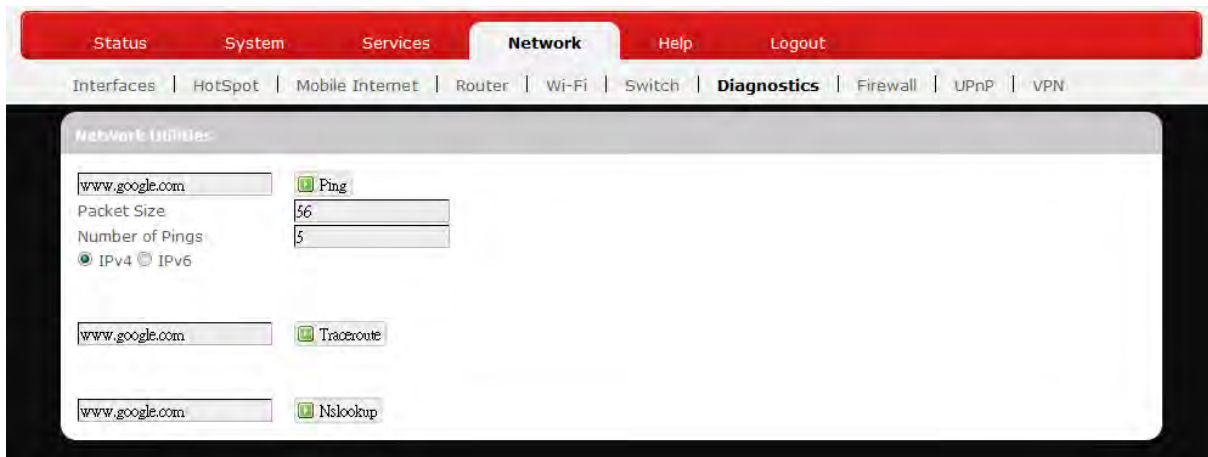

This submenu contains tools for effective network analysis and troubleshooting.

### Network Utilities

#### Ping

<input type="text" value="www.google.com"/>	<input type="button" value="Ping"/>
Packet Size	<input type="text" value="56"/>
Number of Pings	<input type="text" value="5"/>
<input checked="" type="radio"/> IPv4 <input type="radio"/> IPv6	

This feature allows you to check the status of a connection.

1. In the text box next to  , enter the IP address or URL that you want to ping, and then select its corresponding internet protocol by clicking either the IPv4 or IPv6 radial button.
2. In the text box of “Packet Size”, enter the desired value (default packet size is 56).
3. In the text box of “Number of Pings”, enter the number of times you wish to ping (default value is 5).
4. Click  to begin the connection status check. ‘Ping’ messages will appear below.

#### Traceroute

<input type="text" value="www.google.com"/>	<input type="button" value="Traceroute"/>
---	---



This feature allows you to check the performance of a connection.

- 
1. In the text box next to , enter the IP address or URL that you want to trace route, and then click  to start the performance test. 'Traceroute' messages will appear below.

### ***NS Lookup***

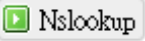

This feature allows you to retrieve name server information.

1. In the text box next to , enter the IP address or URL that you want to trace route, and then click  to get name server information. 'Nslookup' messages will appear below.

# Firewall

## Single Port Forward

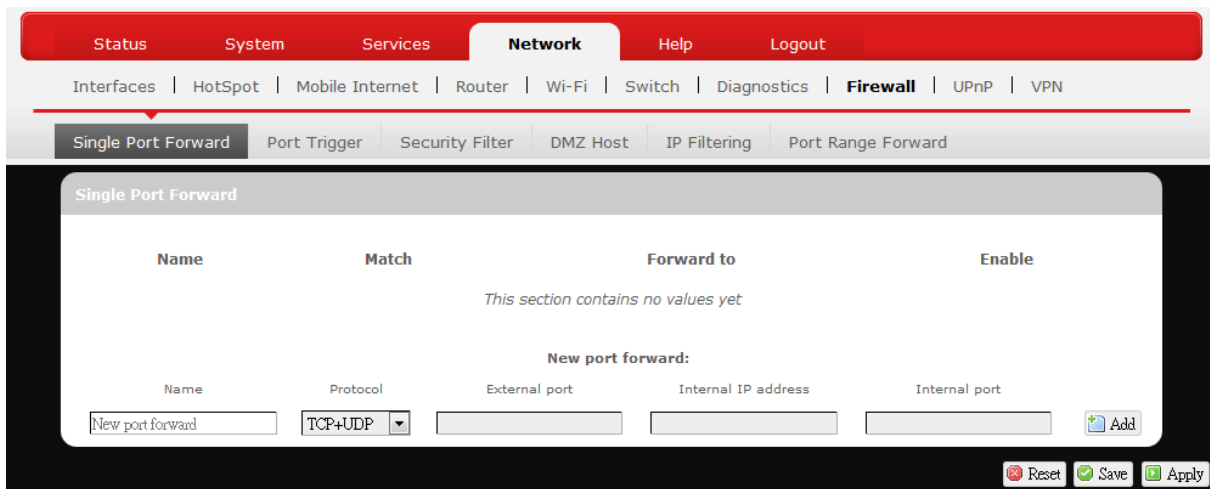



### Single Port Forward

Port Forwarding allows you to set up public services on your network, such as web servers, ftp servers, e-mail servers, and other specialized Internet applications.

To forward a single port:

The screenshot shows the 'New port forward:' form with the following values entered: Name: LuxeFWD1, Protocol: TCP+UDP (selected from a dropdown), External port: 8001, Internal IP address: 192.168.1.194, and Internal port: 8001. An 'Add' button is visible to the right of the Internal port field.

1. **Name:** Enter an application name for this port forwarding rule.
2. **Protocol:** Click  and select a protocol from the drop down list – *TCP+UDP* (default), *TCP*, *UDP*, or *Other...*
3. **External port:** Enter the port number of the external port used by the server or Internet application. Afterward, this port number will be echoed to the text box of “Internal port”.
4. **Internal IP address:** Click  and select an IP address from drop-down list, or select “--custom--” and enter IP address in text box.
5. **Internal port:** This text box will automatically receive port number entered in the text box of “External port”, or you can enter your own port number in the same text box.
6. Click . The port forwarding rule you have just entered will be added to the Port Forwards list.

Name	Match	Forward to	Enable
LuxeFWD1	IPv4-TCP, UDP From <i>any host</i> in wan Via <i>any router IP</i> at port 9001	192.168.1.194, port 9001 in lan	<input checked="" type="checkbox"/>  



(a) (b)



New port forward:

Name	Protocol	External port	Internal IP address	Internal port
<input type="text" value="New port forward"/>	TCP+UDP	<input type="text"/>	<input type="text"/>	<input type="text"/>

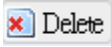

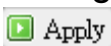
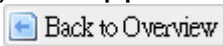
In the status area, the message **Unapplied Change** may appear next to “Operator Name” to indicate configuration changes temporarily stored in the router.

7. More rules can be added to the Port Forwards list by repeating Steps 1-6.
8. (a) To enable or disable a Port Forwards list rule, click its check box under ‘Enable’.  
(b) To remove any Port Forwards rule, click its corresponding  button.
9. To edit a particular Port Forwards rule in detail, click its corresponding  button, and the rule’s associated configuration page (much more flexible and detailed than express settings in Steps 1-5) will appear. After making any changes, click . Finally click  to exit this configuration page.

Rule is enabled	
Name	<input type="text" value="LuxeFWD1"/>
Protocol	TCP+UDP
External port	<input type="text" value="9001"/> <small> Match incoming traffic directed at the given destination port or port range on this host</small>
Internal IP address	192.168.1.194 (User-NB2) <small> Redirect matched incoming traffic to the specified internal host</small>
Internal port	<input type="text" value="9001"/> <small> Redirect matched incoming traffic to the given port on the internal host</small>
Enable NAT Loopback	<input checked="" type="checkbox"/>

**Note:** Numerical and text values shown in the illustrative examples are for demonstration purposes only and are not for actual operation.

## Port Trigger

The screenshot shows a web interface for configuring Port Triggering. The navigation menu includes Status, System, Services, Network (selected), Help, and Logout. The Network menu is expanded to show Interfaces, HotSpot, Mobile Internet, Router, Wi-Fi, Switch, Diagnostics, Firewall (selected), UPnP, and VPN. The Firewall menu is further expanded to show Single Port Forward, Port Trigger (selected), Security Filter, DMZ Host, IP Filtering, and Port Range Forward. The Port Trigger configuration page is displayed, showing a table with columns for Name, Trigger Range, Forward Range, and Enable. The table is currently empty, with the message "This section contains no values yet". Below the table is a form with fields for Name, Protocol, Triggered Range (Start Port, End Port), and Forwarded Range (Start Port, End Port). The form is currently empty, with "New port trigger" in the Name field and "TCP+UDP" in the Protocol dropdown. There are "Reset", "Save", and "Apply" buttons at the bottom right.

### Port Trigger

Port Triggering allows the Router to watch outgoing data for specific port numbers. The Router remembers the IP address of the computer that sends the matching data, so that when the requested data returns through the Router, the data is pulled back to the proper computer by way of IP address and port mapping rules.

To add a new Port Triggering rule:

The screenshot shows the Port Trigger configuration form with the following values: Name: LuxeTrig1, Protocol: TCP+UDP, Triggered Range Start Port: 10, Triggered Range End Port: 80, Forwarded Range Start Port: 10, Forwarded Range End Port: 80. There is an "Add" button to the right of the form.

1. **Name:** enter an application name for this port triggering rule.
2. **Protocol:** click  and select a protocol from the drop down list – *TCP+UDP* (default), *TCP*, *UDP*, or *Other...*
3. **Triggered Range:** enter the **Start Port** and **End Port** for the triggered port number range of the Internet application (please check its documentation for the port number(s) needed).
4. **Forwarded Range:** enter the **Start Port** and **End Port** for the forwarded port number range of the Internet application (please check its documentation for the port number(s) needed).



- Click . The port triggering rule you have just entered will be added to the Port Triggering list.

Name	Trigger Range	Forward Range	Enable
LuxeTrig1	IPv4-TCP, UDP Start port 10 to port 80	Open port 10 to port 80	<input checked="" type="checkbox"/>

(a) (b)

Name	Protocol	Triggered Range	Forwarded Range		
Name	Protocol	Start Port	End Port	Start Port	End Port
<input type="text" value="New port trigger"/>	<input type="text" value="TCP+UDP"/>	<input type="text"/>	<input type="text"/>	<input type="text"/>	<input type="text"/>

In the status area, the message **Unapplied Change** may appear next to “Operator Name” to indicate configuration changes stored in the router.

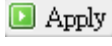
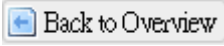
- More rules can be added to the Port Triggering list by repeating Steps 1-5.
- (a) To enable or disable a Port Forwards list rule, click its check box under ‘Enable’.  
(b) To remove any Port Triggering rule, click its corresponding  button.
- To edit a particular Port Triggering rule in detail, click its corresponding  button, and the rule’s associated configuration page (more flexible and detailed than express settings in Steps 1-4) will appear. After making any changes, click . Finally click  to exit this configuration page.

Rule is enabled 

Name

Protocol

Trigger start port   
 Only match incoming traffic originating from the given source port or port range on the client host

Trigger end port   
 Only match incoming traffic originating from the given source port or port range on the client host

Forward start port   
 Redirect matched incoming traffic to the given port on the internal host

Forward end port   
 Redirect matched incoming traffic to the given port on the internal host

**Note:** Numerical and text values shown in the illustrative examples are for demonstration purposes only and are not for actual operation.

## Security Filter

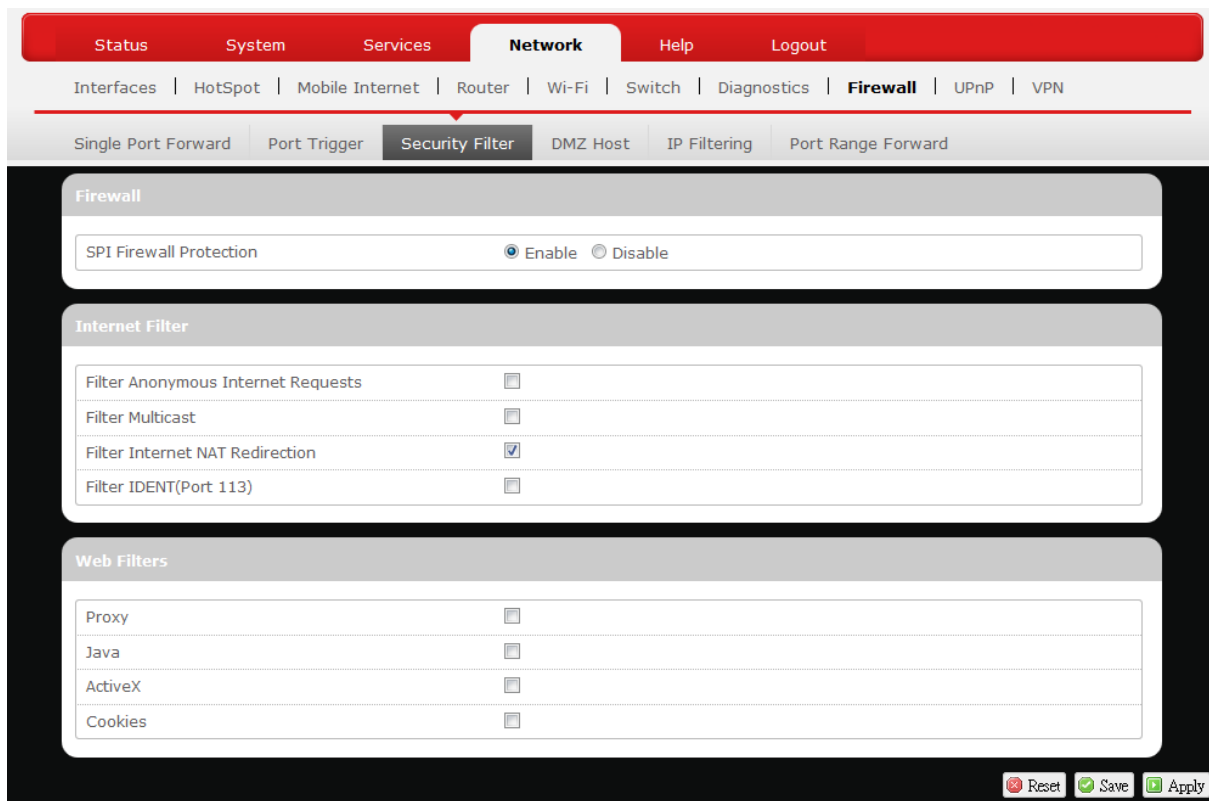

Here you can make **Firewall**, **Internet Filter**, and **Web Filters** adjustments for network security.

### **Firewall**

**SPI Firewall Protection:** Enable or Disable Stateful Packet Inspection (SPI) feature of the firewall. The default setting is 'Enable'.

### **Internet Filter**

**Filter Anonymous Internet Requests:** This filter blocks anonymous internet requests from outside network. The default setting is 'disabled'.

**Filter Multicast:** Multicasting allows for multiple transmissions to specific recipients at the same time, i.e. the Router allows IP multicast packets to be forwarded to the appropriate computers.  
To allow multicasting, disable "Filter Multicast" (this is the default setting).  
To block multicasting, enable "Filter Multicast".



**Filter Internet NAT Redirection:** This filter blocks local resource access via NAT (Network Address Translation) redirection (i.e. external address) from other local computers. The default setting is 'enabled'.

**Filter IDENT (Port113):** This feature keeps Port 113 from being scanned by devices outside of your local network. The default setting is 'disabled'.

### Web Filters

Using the Web Filters feature, you may enable up to four specific filtering methods.

**Proxy:** Use of WAN proxy servers may compromise the Router's security. Select this option to disable access to any WAN proxy servers.

**Java:** Java is a programming language for websites. Select this option to disable Java. If you disable Java, you run the risk of not having access to Internet sites created using this programming language.

**ActiveX:** ActiveX is a programming language for websites. Select this option to disable ActiveX. If you disable ActiveX, you run the risk of not having access to Internet sites created using this programming language.

**Cookies:** A cookie is data stored on your PC and used by Internet sites when you interact with them. Select this option to disable cookies.

### DMZ Host

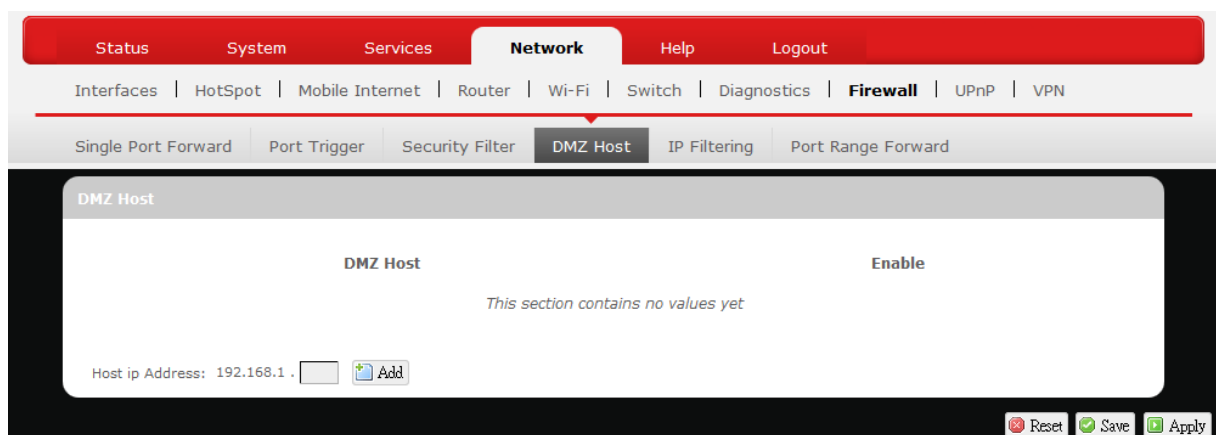

When a firewall is used, it is sometimes necessary to place some clients (for example Internet games, video conferencing, or VPN connections) outside of the firewall while leaving the others protected. You can do this using a Demilitarized Zone (DMZ). This DMZ Host feature allows you to specify the IP address of the computers that are placed outside the firewall of your network.

In the text box, enter the last 3 digits of the DMZ host address (the prefix is 192.168.1 for this router), and then click .

Host ip Address: 192.168.1.  

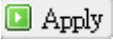
The host IP address will be added to the DMZ Host list, which can be further disabled or enabled by clicking the 'Enable' checkbox. To remove this DMZ Host, click . After setting up the DMZ host, click .

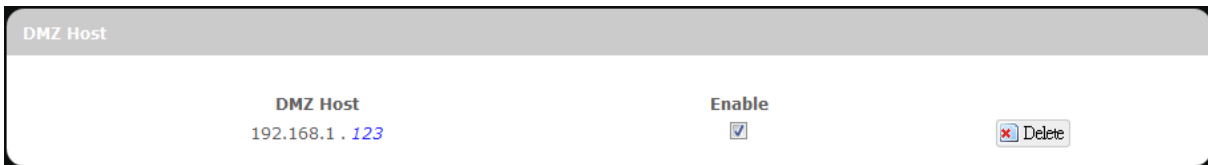

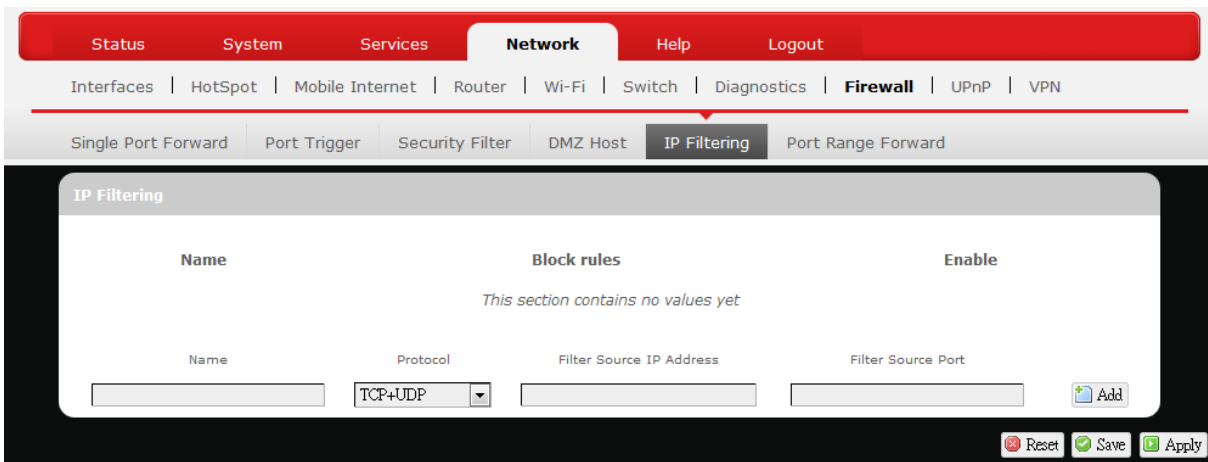

## IP Filtering





### IP Filtering

IP Filtering allows the Router to discard data from certain IP addresses. To add a new IP filtering rule:



Name	Protocol	Filter Source IP Address	Filter Source Port	
<input type="text" value="Luxefilt1"/>	<input type="text" value="TCP+UDP"/>	<input type="text" value="111.222.156.1"/>	<input type="text" value="10"/>	

- Name:** Enter an application name for this IP filtering rule.
- Protocol:** Click  and select a protocol from the drop down list – *TCP+UDP* (default), *TCP*, *UDP*, or *Other...*

- Filter Source IP Address:** Enter the source IP address to be filtered. The text color will turn red with  on the right for any invalid IP address entered (e.g. ). When the IP address entered becomes valid, the text color changes back to black without  on the right (e.g. ).
- Filter Source Port:** Enter the source port number to be filtered.
- Click . The IP filtering rule you have just entered will be added to the IP Filtering list.

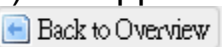

In the status area, the message **Unapplied Change** may appear next to “Operator Name” to indicate configuration changes stored in the router.

- More rules can be added to the IP filtering list by repeating Steps 1-5.
- (a) To enable or disable an IP filtering list rule, click its check box under ‘Enable’.
- (b) To remove any Port Triggering rule, click its corresponding  button.
- To edit a particular IP filtering rule in detail, click its corresponding  button, and the rule’s associated configuration page (more flexible and detailed than express settings in Steps 1-4) will appear. After making any changes, click . Finally click  to exit this configuration page.

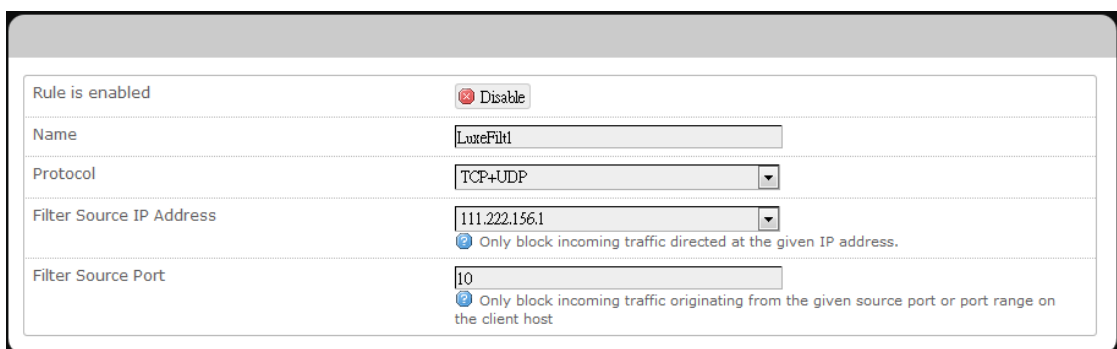

**Note:**

Numerical and text values shown in the illustrative examples are for demonstration purposes only and are not for actual operation.

## Port Range Forward

### Port Range Forward



Port Range Forward allows you to set up public services on your network, such as web servers, ftp servers, e-mail servers, and other specialized Internet applications.

To forward a port range:

1. **Name:** Enter an application name for this port range forwarding rule.
2. **Protocol:** Click  and select a protocol from the drop down list – *TCP+UDP* (default), *TCP*, *UDP*, or *Other...*
3. **Port Range Forward:** Specify the range of port forwarding by entering the **Start Port** number and the **End Port** number.
4. **IP address:** Enter the IP address of the PC running the specific application.

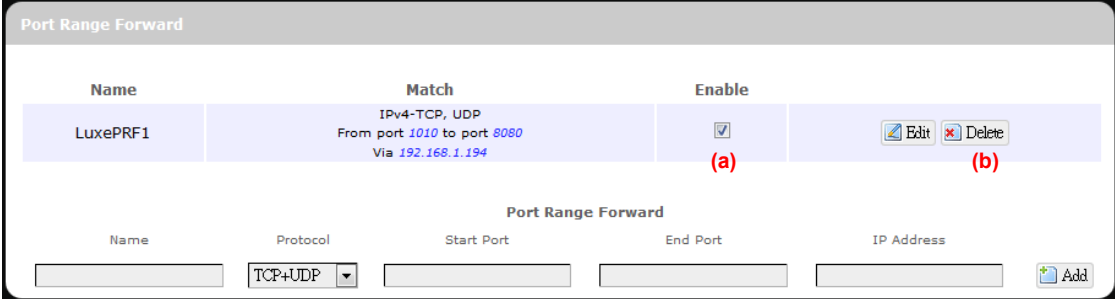
- Click . The port range forwarding rule you have just entered will be added to the Port Range Forward list.





Name	Match	Enable	
LuxePRF1	IPv4-TCP, UDP From port 1010 to port 8080 Via 192.168.1.194	<input checked="" type="checkbox"/>	 

Port Range Forward

Name	Protocol	Start Port	End Port	IP Address	
<input type="text"/>	TCP+UDP	<input type="text"/>	<input type="text"/>	<input type="text"/>	

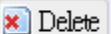
In the status area, the message **Unapplied Change** may appear next to “Operator Name” to indicate configuration changes temporarily stored in the router.

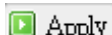
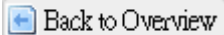
- More rules can be added to the Port Range Forward list by repeating Steps 1-5.
- (a) To enable or disable a Port Forwards list rule, click its check box under ‘Enable’.  
(b) To remove any Port Forwards rule, click its corresponding  button.
- To edit a particular Port Forwards rule in detail, click its corresponding  button, and the rule’s associated configuration page (more flexible and detailed than express settings in Steps 1-4) will appear. After making any changes, click . Finally click  to exit this configuration page.

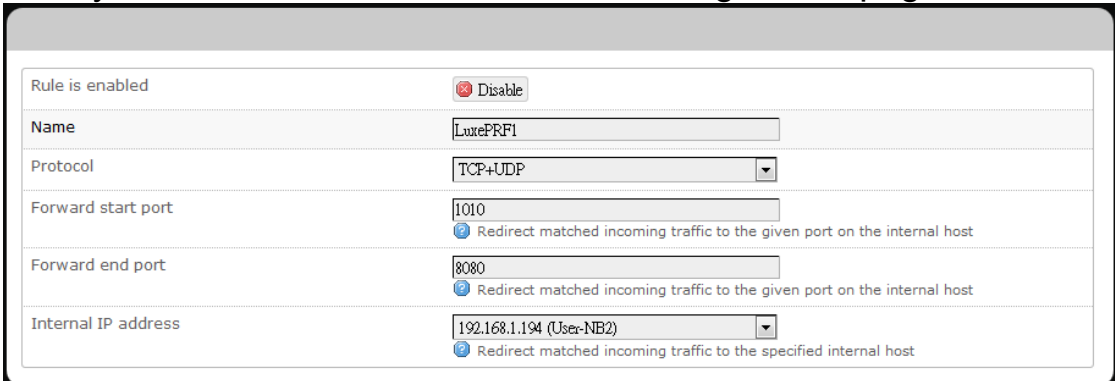

Rule is enabled	<input checked="" type="checkbox"/> Disable
Name	LuxePRF1
Protocol	TCP+UDP
Forward start port	1010 <input checked="" type="radio"/> Redirect matched incoming traffic to the given port on the internal host
Forward end port	8080 <input checked="" type="radio"/> Redirect matched incoming traffic to the given port on the internal host
Internal IP address	192.168.1.194 (User-NB2) <input checked="" type="radio"/> Redirect matched incoming traffic to the specified internal host

**Note:** Numerical and text values shown in the illustrative examples are for demonstration purposes only and are not for actual operation.

## UPnP

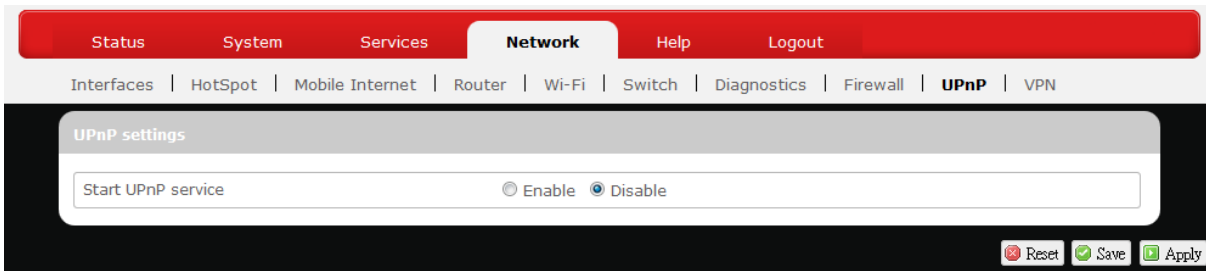

Universal Plug and Play – Allows wired and wireless network devices to discover each other and establish network services.

### UPnP Settings

Here you can 'Enable' or 'Disable' the UPnP service.

## VPN

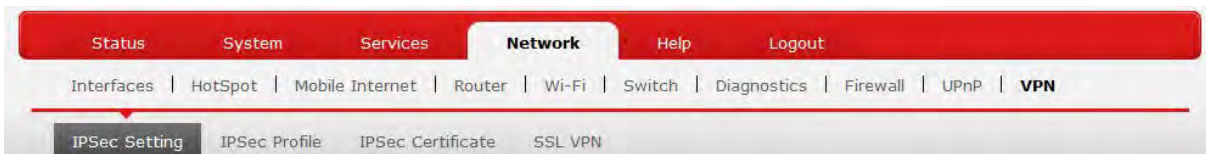

Virtual Private Network – Allows use of mobile internet for secured private network.

### IPSec Setting

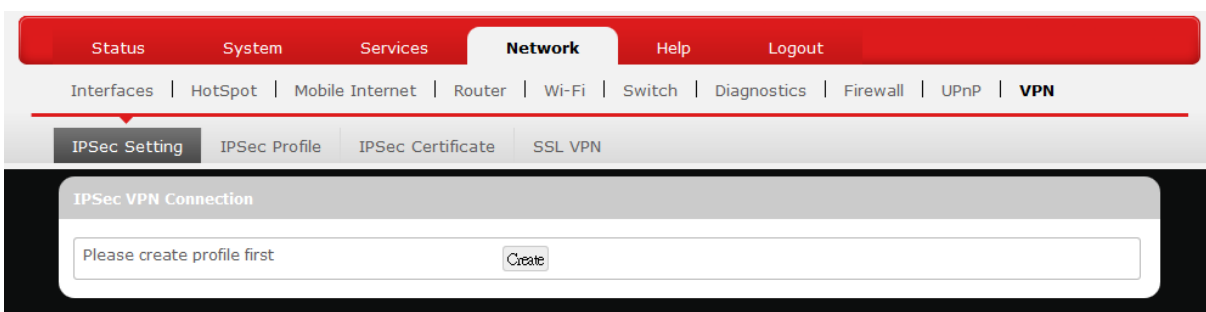

### IPSec VPN Connection

First click **Create** to create a profile, then follow subsequent instructions.

## IPSec Profile

The screenshot shows a network management interface with a red navigation bar at the top containing 'Status', 'System', 'Services', 'Network', 'Help', and 'Logout'. Below the navigation bar is a breadcrumb trail: 'Interfaces | HotSpot | Mobile Internet | Router | Wi-Fi | Switch | Diagnostics | Firewall | UPnP | VPN'. Underneath, there are tabs for 'IPSec Setting', 'IPSec Profile', 'IPSec Certificate', and 'SSL VPN'. The main content area is divided into two sections: 'IPSec profile Overview' and 'IPSec VPN connection status'. The 'IPSec profile Overview' section contains a table with columns 'Name', 'Status', and 'Actions', and an 'Add New Profile' button. The 'IPSec VPN connection status' section contains a table with columns 'VPN name', 'Network Endpoint', 'Virtual Network', 'IKE Alg', 'IPSec Alg', 'Tx(Byte)', 'Rx(Byte)', and 'Uptime'. Below the table, it says 'Collecting data...'.

### *IPSec profile Overview*

First click **Add New Profile** to create a profile, then follow subsequent instructions.

### *IPSec VPN connection status*

Here you can view the status of VPN connection. The displayed information are **VPN name**, **Network Endpoint**, **Virtual Network**, **IKE Alg** (Internet Key Exchange Application Level Gateway), **Tx(Byte)** (transmitted data in bytes), **Rx(Byte)** (received data in bytes), and **Uptime** (the amount of time that the network is running).

## IPSec Certificate

The screenshot shows the same network management interface as above, but with the 'IPSec Certificate' tab selected. The main content area is titled 'IPSec VPN Connection' and contains a message: 'This section contains no values yet'. Below the message is an 'Add' button. At the bottom right of the page, there are three buttons: 'Reset', 'Save', and 'Apply'.

### *IPSec VPN Connection*

This setting allows you to use an IPSec Certificate for the VPN connection.

To setup an IPSec VPN Connection:

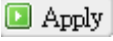
1. **PKCS#12 Profile Name:** Enter the profile name for the PKCS #12 certificate file to be used.
2. **PKCS#12 file password:** Enter the password for the PKCS #12 certificate file to be used.
3. **User Private Key password:** Enter the user private key password associated with the VPN connection.
4. **PKCS#12 file containing keys:** Click **Browse** and select the PKCS#12 certificate file to be used for the VPN connection.
5. To use an additional IPsec certificate, click  and repeat Steps 1-4.
6. After making all changes, click .

## SSL VPN

This submenu setting hosts configuration options for SSL VPN (Secure Socket Layer Virtual Private Network).

**SSL Certificate:** Displays SSL Certificate information.

**Path to CA-Certificate:** Click  and select an appropriate CA-Certificate file.

After making any changes, click .



# Help

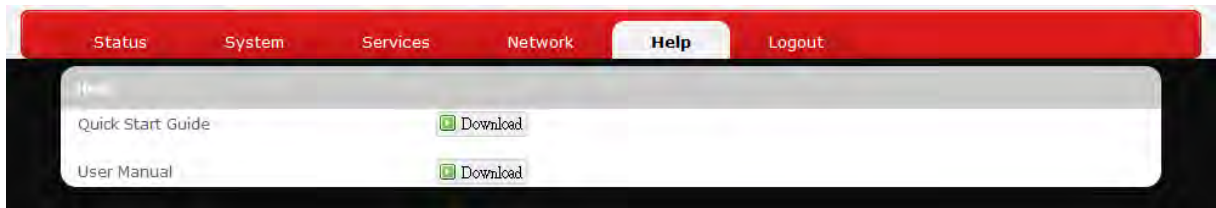

Click the appropriate download link to download the latest Quick Start Guide or User Manual of this product.

# Logout

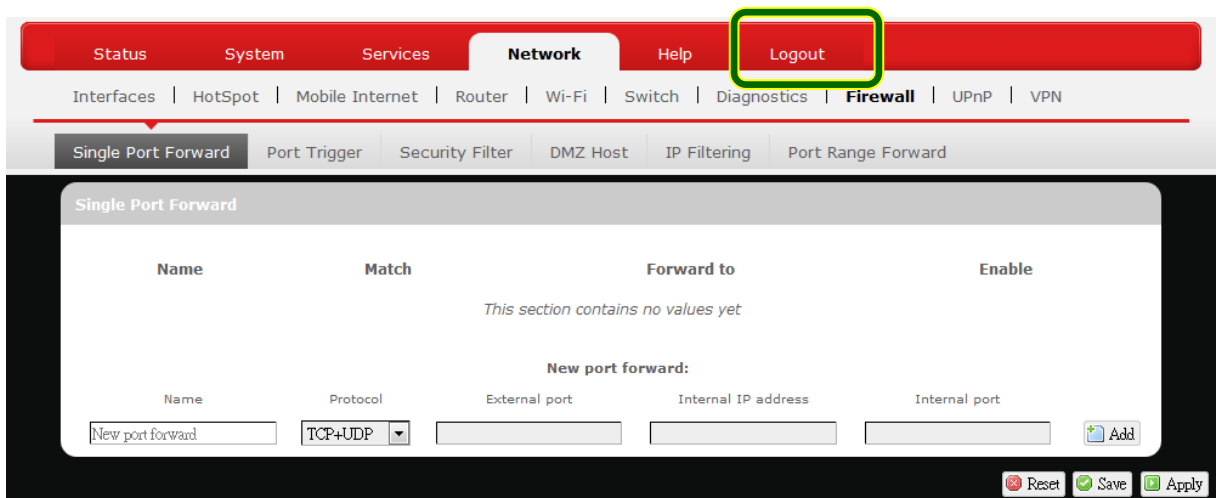

Exits the web configuration interface and re-directs to login prompt.

**Note:** After a period of inactivity, automatic logout will occur. After clicking any menu item, the login prompt will appear as re-login is needed to continue using the web configuration interface.

---

# Appendix A: Vehicle Installation Guide

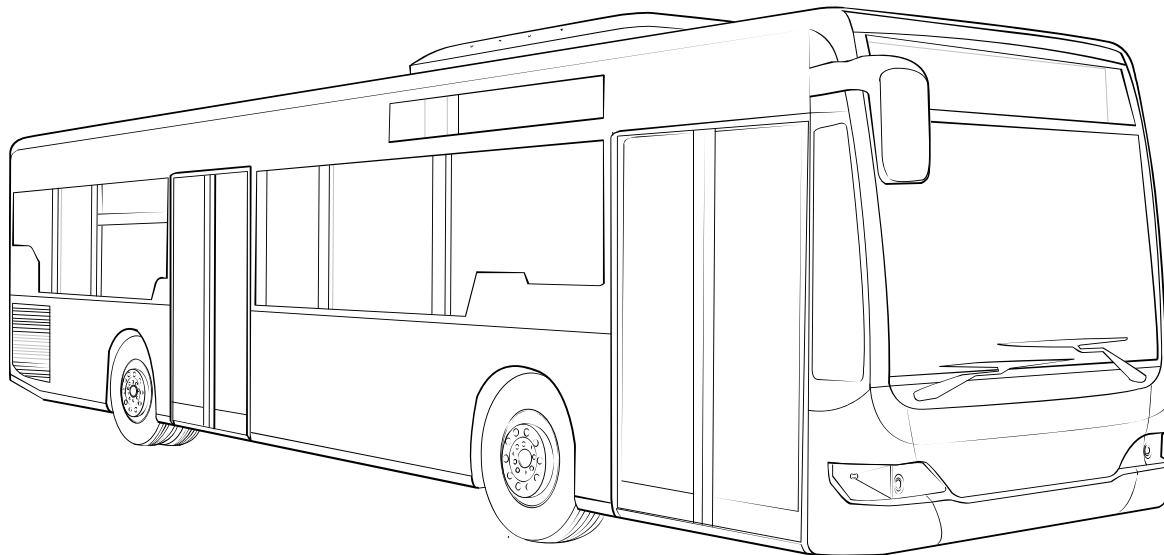

Your K530 is designed for rugged vehicle use with MIL810G compliance, ***please review and consider the guidelines below for optimal vehicle installation.***

## Overview

A stable power supply and secure mounting are essential to ensure that your K530 operates properly. However, getting a stable power supply from an operating vehicle can be a major challenge due to constantly changing vehicle and environmental conditions. Furthermore, different circuit loadings as a result of vehicle operation and use of its onboard electronic products can cause the raw voltage supplied by a vehicle's battery to vary largely. Therefore, unless modified, a vehicle's electrical system is generally quite unreliable for onboard electrical equipment.

There are two basic types of voltage supply problems in a vehicle. One is called *brown-out*, and the other is called *transient voltage*.

*Brown out* usually occurs during the start of the engine. In general, when a car engine starts, the spark plug draws a significant stream of instantaneous electrical power from the car's battery (ultra high

instantaneous electrical current in terms of hundreds of cranking amps or more) which leaves insufficient energy for other electrical equipment on the vehicle. Therefore, the voltage supplied to all other electrical equipment drops to a significantly lower level than what is normal. It is only after such an instantaneous high demand of electrical power that the voltage level on the vehicle returns to normal. The diagram below demonstrates the brown-out phenomenon during the engine's startup.

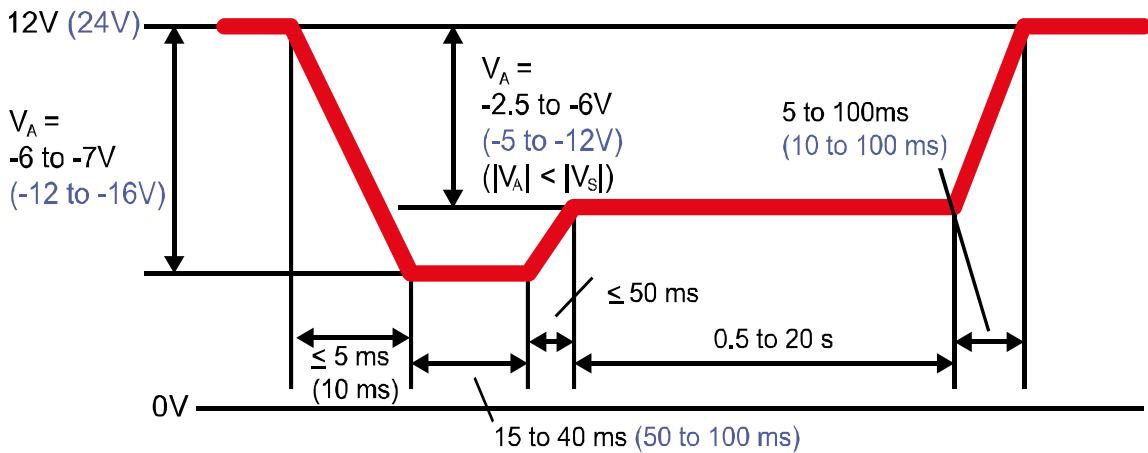

*Transient voltages*, sometimes known as *spikes*, are very noticeable positive or negative voltage changes over a short period of time. Such voltage fluctuations may be occasional or may be periodic. They are typically caused by interference from electrical-mechanical components in a vehicle (such as alternators, electric windows and door locks, light switches, loose or corroded connectors or battery terminals, etc.), or even from additional electrical equipment connected to the vehicle's electrical power system. Without treatment, sharp *spikes* are a potential threat to your K530 as well as other electrical equipment on the vehicle. The diagram below shows some standardized examples of automotive voltage transients (ISO-7637-2):

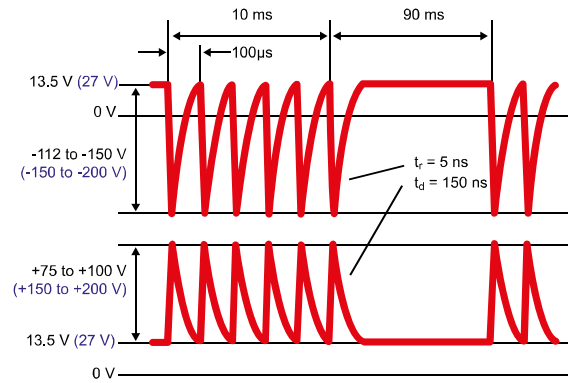
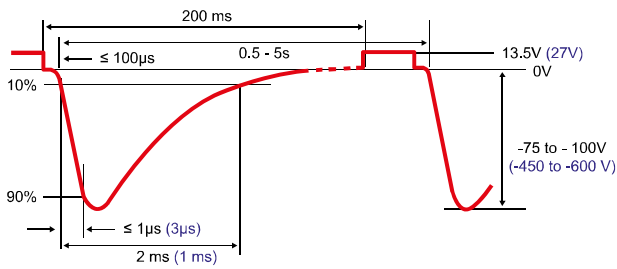

In cases of undesirable voltage transients or brown-outs, your K530 is designed to handle large voltage swings from 9V to 32V. However, for optimal use and proper protection of your K530, it is necessary to regulate the input voltage before feeding it to the power input of your K530.

There are two ways to regulate electrical voltage. One way is to implement a power management block that harnesses battery power during engine startup. The other, more effective, way is to implement a power management block with filters that further smooth out residual spikes.

## Installation

### **General Guidelines**

Follow these guidelines for optimal installation of your K530 in a vehicle:

- Place the router as close as possible to the voltage regulators, such as power management block and filters. Use short power cables to keep the distance short between the router and the output connectors of the voltage regulators.

- Use proper wire size according to the expected current load.

Electric Current Load (Amps)	AWG Rating	
	10-Foot Cable	20-Foot Cable
3-10	14 AWG	12 AWG
11-20	14 AWG	10 AWG
21-35	8 AWG	6 AWG

- A dedicated ground wire is highly recommended instead of direct attachment to chassis ground.

*NOTE: To minimize noise interference, a filter can be applied isolating the router from other electrical devices.*

## **Mounting**

To ensure that your K530 is securely mounted, 4 screws can be applied as shown in the figure below. In addition to electrical requirements, also consider temperature factors when choosing a location for mounting your K530.

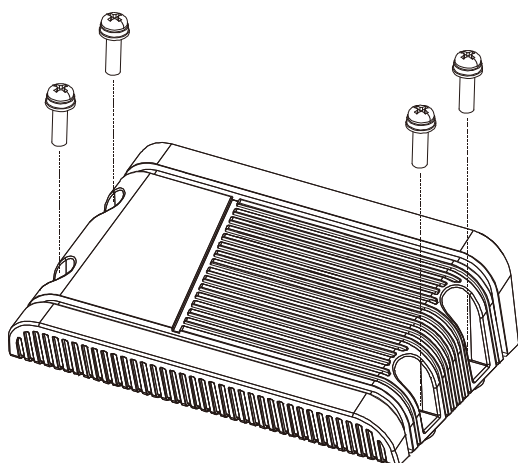

If problems caused by vibration are noticeable, anti-vibration rubber grommets may be used to reduce shock on your K530. Also avoid mounting your K530 near an area that is subject to extreme heat, such as

a poorly ventilated spot that is either near the engine or is prone to direct sunlight.

## ***Basic Power Management***

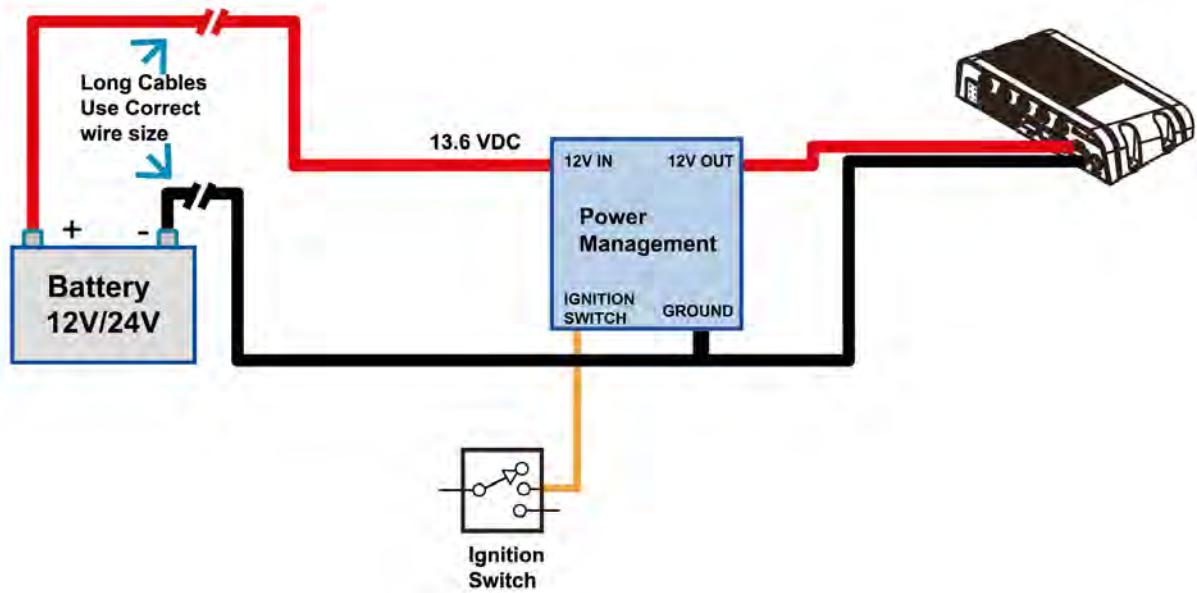

In this type of installation, voltage is regulated solely on the power management block, which routes battery power to the ignition switch during engine startup while rendering conditioned output DC power to the vehicle's electrical parts. First connect the long red positive power cable to the input of the power management block. Then connect the conditioned positive power output to your K530. On the ground side, connect the ground from your K530 to the ground of the power management block and the ground of the battery.

## Power Management with a Filter

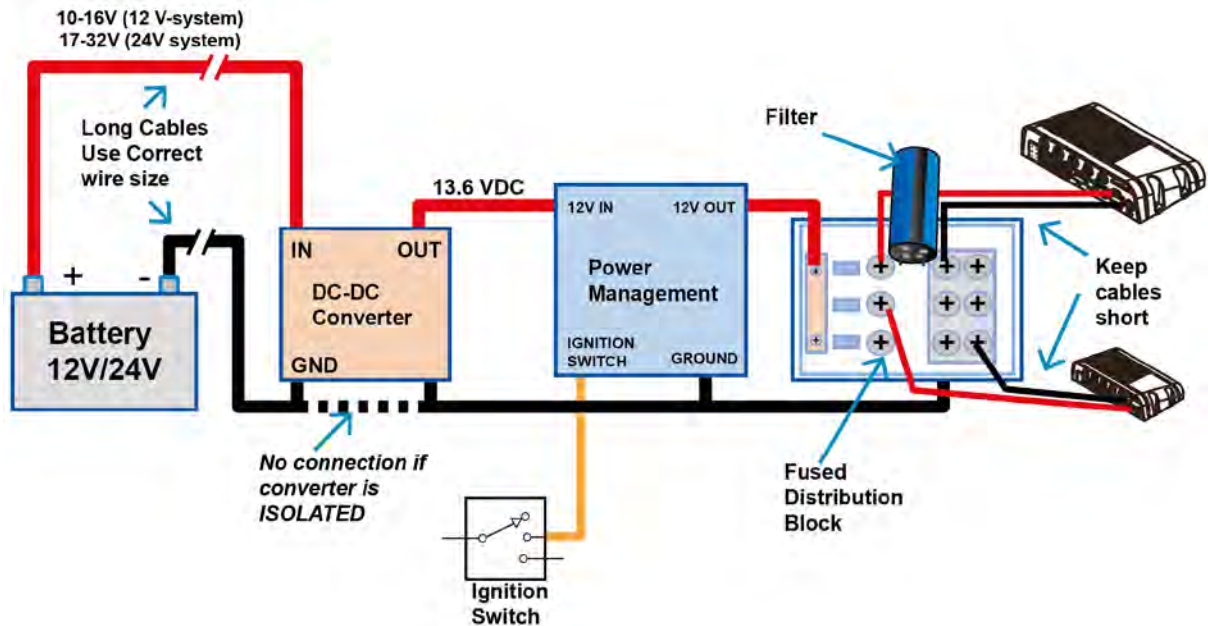

In this type of installation, voltage is regulated in two parts. The first part is on the power management block, which routes battery power to the ignition switch during engine startup while rendering conditioned output DC power to the vehicle's electrical parts. First connect the long red positive power cable to the input of the power management block. Then connect the conditioned positive power output to your K530. On the ground side, connect the ground from your K530 to the ground of the power management block and the ground of the battery.

The second part further conditions power voltage via the use of a filter, which helps further smooth out residual transients left over by the power management block. There are three types of filters: capacitor, inductor, and Pi.

A capacitor reduces transients by temporarily storing electrical energy in an electrostatic field and gradually releasing them over time.

The inductor reduces transients by temporarily storing some electrical energy in a magnetic field and gradually releasing them over time.

The Pi filter reduces transients using a specially designed RLC circuit, which combines the function of both capacitors and inductors by utilizing the transient-reducing characteristics of both types of filters.

Though any of the three types of filters will do the job, the Pi filter is the recommended choice, because it combines the advantages of both capacitor and inductor filters.

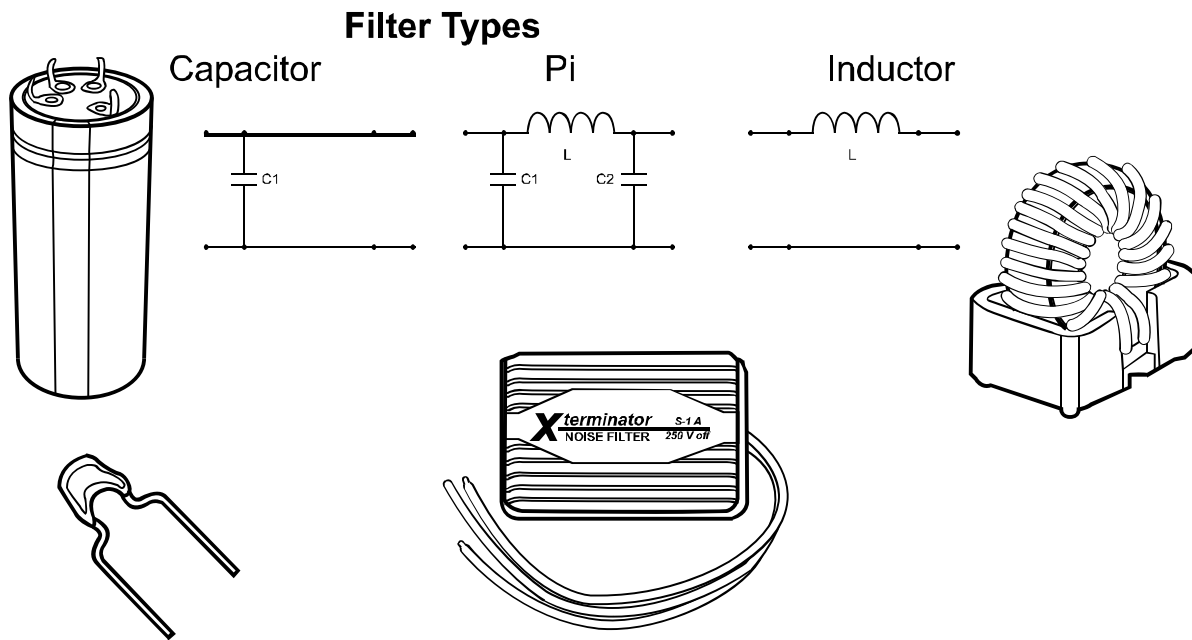



---

## Appendix B: FAQ

Q: What should I know and how long does it take when I upgrade the firmware of router or modem?

- A:
1. While upgrading the firmware requires some time to finish. During that, you **MUST NOT** turn off the power or interrupt the progress.
  2. You may use an Ethernet cable or a wireless connection to upgrade the firmware. We **suggest the use of an Ethernet cable**.
  3. It may take **2 minutes to upgrade the firmware of the router** and **5 minutes to upgrade the firmware of the modem**.
  4. When the firmware of the modem is upgrading, the UMTS LED will flash among **Blue-Green-Red**. You should wait until the LED is in single color (about 4-5 minutes).

Q: How do I connect to the router?

- A:
1. Connect an Ethernet cable between PC/Notebook (NB) and the router.
  2. Use WiFi to connect.

Q: What's the default "User name" and "Password" for the router?

- A: User name: admin  
Password: admin

Q: How do I enter GUI and setup the configuration for the router?

- A:
1. Connect PC/NB to the router.
  2. Open Internet Explorer or other Web browser.
  3. Input "http://192.168.1.1".
  4. Input User name and Password.

Q: Why can't I connect to the network via built-in 3G module?

- A:
1. Check the SIM/USIM to see if it is inserted well.
  2. Check the UMTS LED on the router to see if it is solid.
  3. Check the Status on GUI to see if the SIM/USIM detected well.
  4. Check the Status on GUI to see if the APN it is correct.
  5. Check the Internet on GUI to see if the Connection is "Keep Alive" or not.

Q: Why can't I link on the GUI?

- A: If you have changed your WiFi security, SSID, Local IP address, you have to repair your network to get a new IP that you can link the GUI.

**XP:**

If you are a WiFi user, click **Network Connections** and right click on

## Wireless Network Connection, click **Repair**.

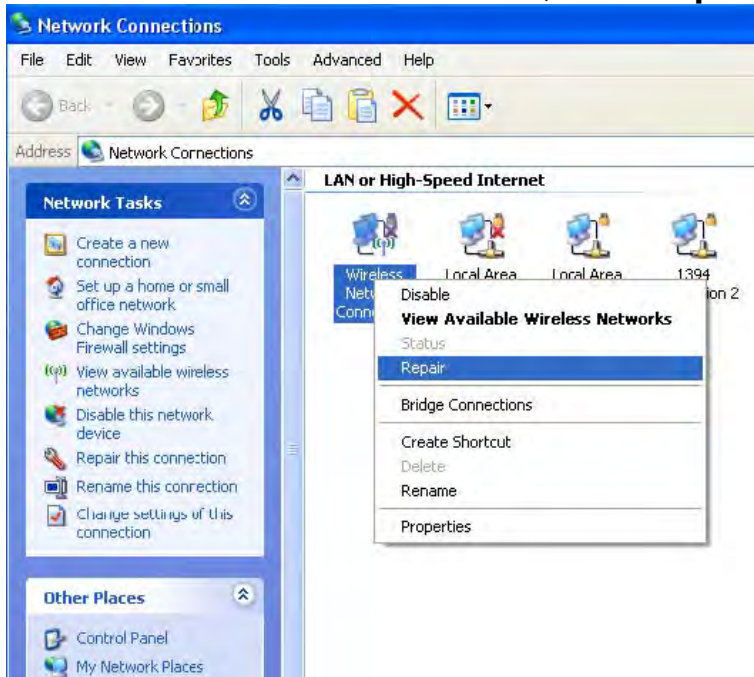

If you use Local Area Connection to connect the Router, click **Network Connections** and right click on **Local Area Connection**, click **Repair**.

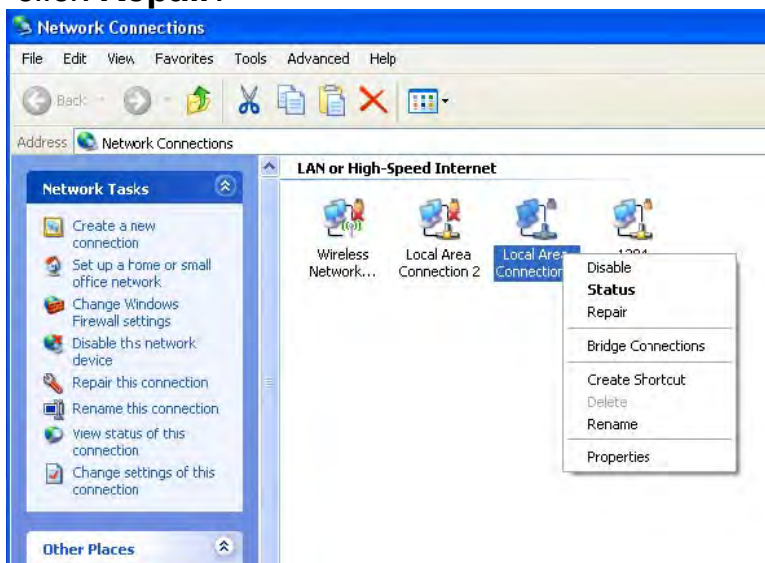

### Vista/7:

1. If you are a WiFi user, please click **Network and Sharing Center > Manage network connections > Wireless Network Connection > Diagnose**.

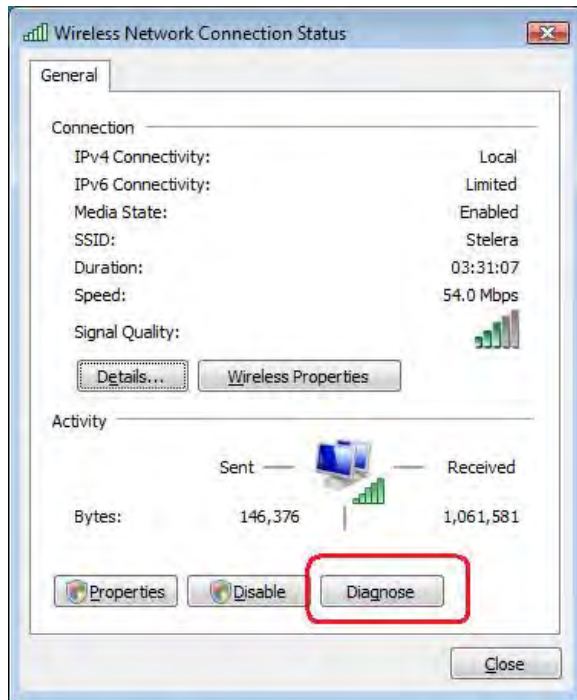

2. Please click **Reset the network adapter “Wireless Network Connection”** and it will began to repair.

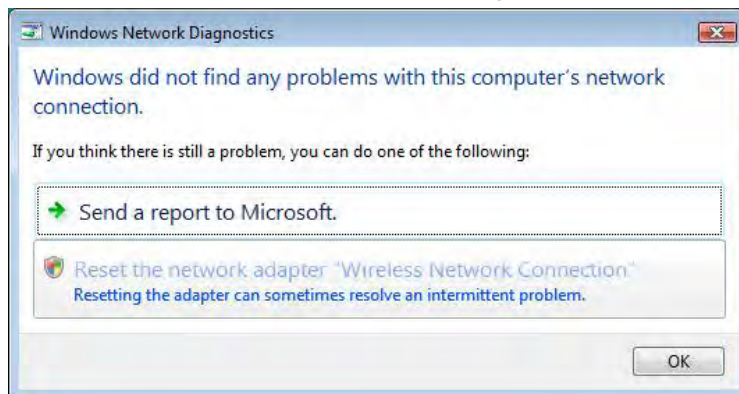

3. If you use Local Area Connection to connect the Router, please click **Network and Sharing Center > Manage network connections > Local Area Connection > Diagnose**, follow step 1 and the subsequent messages to repair it.

Q: How do I configure my WiFi settings from GUI?

A: Click the menu tabs **Network → Wi-Fi** to access to the [Wi-Fi](#) submenu, and then click the submenu tab of a particular ESSID. If you want to configure WiFi Security please click the “[Wireless Security](#)” tab under “Interface Configuration”.

There are seven wireless security encryption options supported by the Router: **WEP Open System, WEP Shared Key, WPA-PSK, WPA2-PSK, WPA-PSK/WPA2-PSK Mixed Mode, WPA-EAP, and WPA2-EAP.**

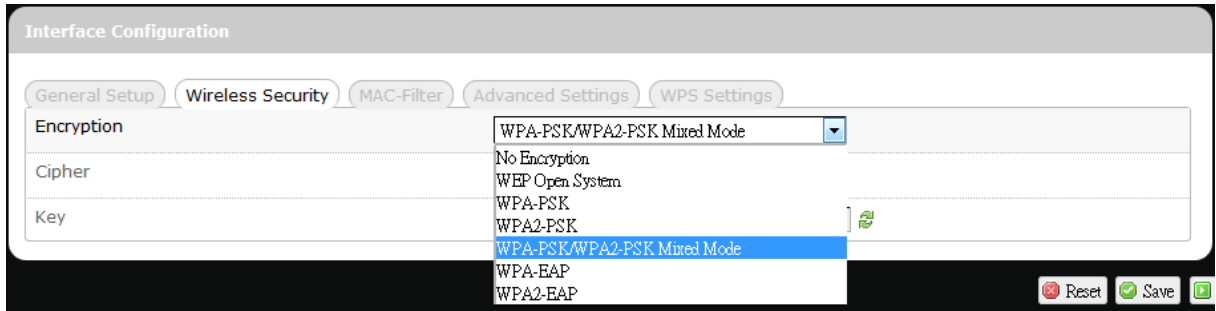

Q: How can I have a long-time link?

A: Click the menu tabs **Network → Router → Router Setting**. Under “DHCP Service”, set Client Lease Time to a large value (e.g. 120h = 120 hours = 5 days).

Q: Why can't I use the router in the office?

A: Your router's IP address might conflict with the office default settings.

Q: Why is my internet speed is so slow with the router?

A: 1. Click the menu tabs **Status → Mobile Internet** to check the Rx Signal Strength in dBm. Weak signals will significantly slow down internet speed.



The following table is an approximate guide for signal strength.

Signal Strength	3G/2G/cdma2000 RSSI reading	4G LTE RSRP reading
No signal or weak signal	Weaker than -100 dBm	Weaker than -115 dBm
Strong signal	-76 dBm or stronger	-87 dBm or stronger

- Click the menu tabs **Network** → **Wi-Fi** to access the [Wi-Fi](#) submenu, and then click the submenu tab of the currently used ESSID. Then select a different WiFi Channel under “Device Configuration.”

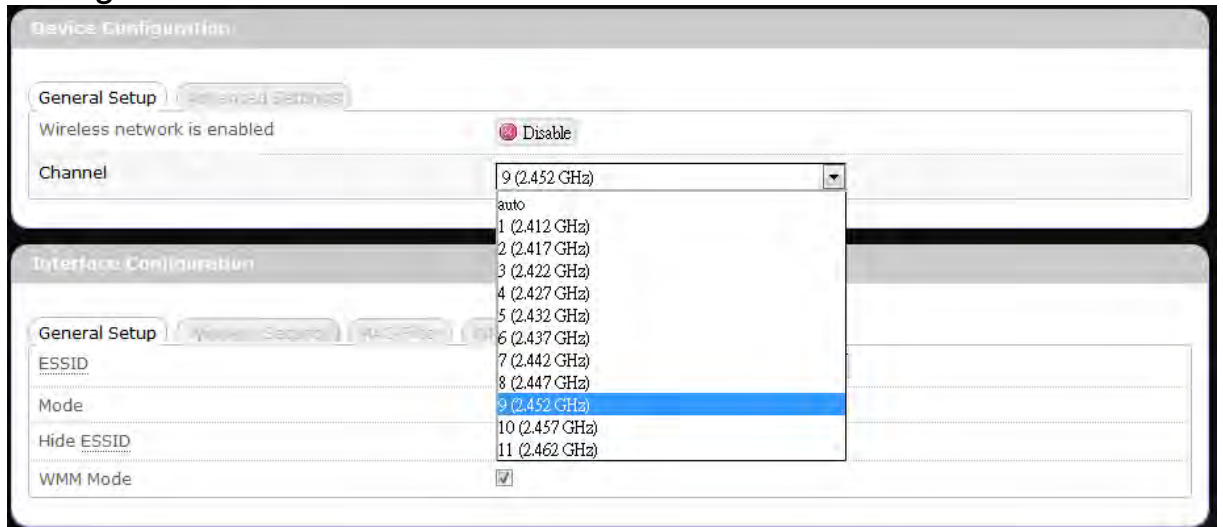

Q: I have connected the computer with the router via LAN connection.

Why can't I access the router's IP address "http://192.168.1.1" ?

A: Your computer's IP address and DNS server addresses may have been assigned manually. Please set your computer's IP address and DNS server addresses to be obtained automatically. The Windows setup path is:  
**Control Panel → All Control Panel Items → Network and Sharing Center → Local Area Connection → Properties → Internet Protocol Version 4 (TCP/IPv4).**

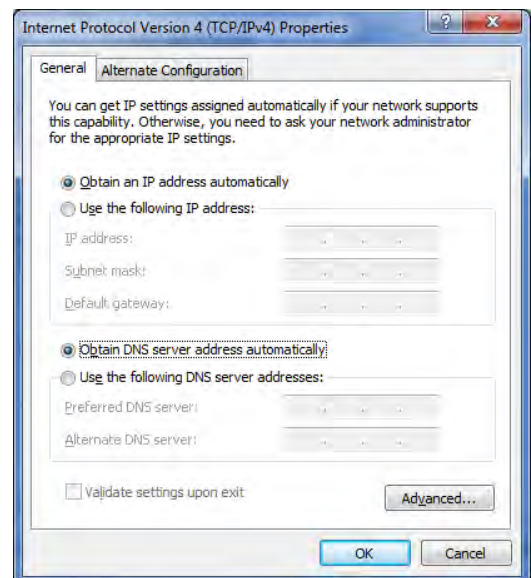

Q: Why can't I use VPN via Router?

A: You may check your office IP settings, the IP settings must not conflict with each other.

Q: How do I configure the settings when I use xDSL to link the router?

- A:
1. PPPoE: Go to the GUI **Internet > Basic Setting > Ethernet Setting**. Change Connection Type to PPPoE. Enter the Username and Password provided by your ISP. Remember to connect your xDSL or Modem to the WAN Port on your Router.
  2. Static IP: Go to the GUI **Internet > Basic Setting > Ethernet Setting**. Change Connection Type to Static IP. Enter the information in the blank provided by your ISP. Remember to connect your xDSL or Modem to the WAN Port on your Router.

Q: Can I prevent others from using my router?

- A: Yes, there are some ways to prevent others from using your router.
1. Enable your WiFi client filter.
  2. Disabled your SSID Broadcast.
  3. Setting your WiFi security.

Q: My PIN code is enabled and where can I input the PIN code to use my Router?

- A: Click the menu tabs **Network → Mobile Internet → U/SIM PIN Management**; enter your PIN Code and click .

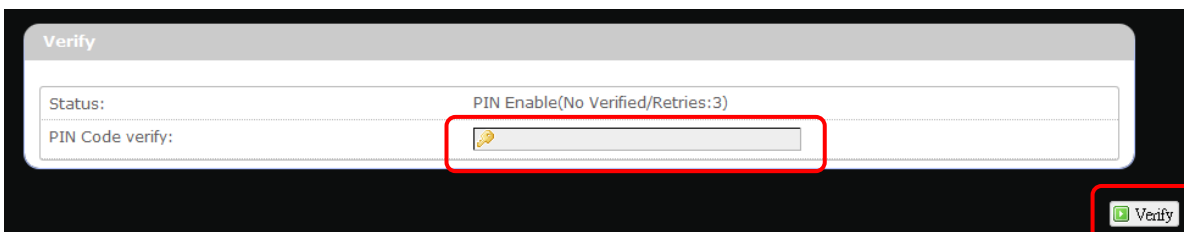

Q: Why does my U/SIM status display “PIN Disable”?

- A: Check that the SIM card (which is properly activated by your mobile internet service provider) is inserted correctly in your router.

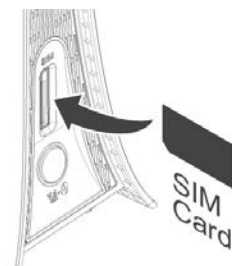

Q: Where can I change the password of the router?

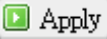
- A: Click the menu tabs **System → Administration**. Enter the new password twice (set and confirm) and click .

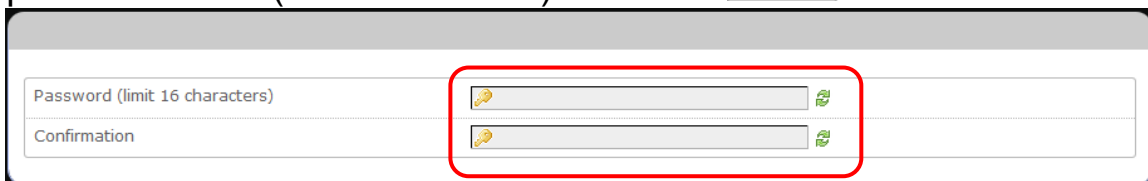



Q: Can I backup and restore all my settings of the router?

A: Yes. Click the menu tabs **System → Backup / Flash Firmware**

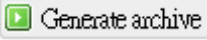
and click , then follow instructions on the screen to save router settings as a TAR file at a desired location on your computer or mobile device. Conversely, to restore previously saved router

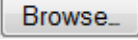
settings, click  (of “Restore backup”); follow screen instructions to choose the previously saved TAR file; and then click

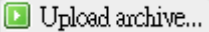
.

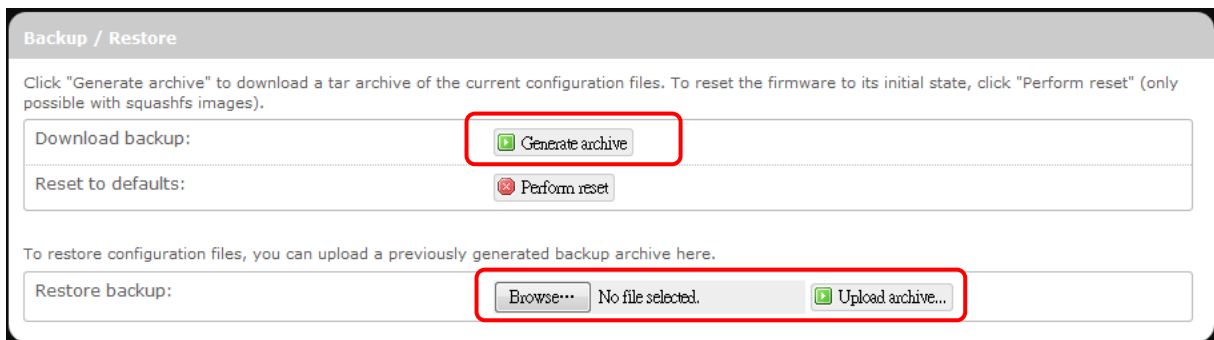

Q: How do I use the **Reset** button on the router?

A: 1. Short press the Reset button to restart the router.

2. Long press the Reset for more than 10 sec to reset the router to factory default settings.

Q: Where can I reset the router to factory default settings?

A: 1. Long press the **Reset** button on the router for more than 10 sec.

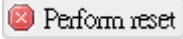
2. Click the menu tabs **System → Backup / Flash Firmware** and click .

Q: If I remove the SIM when 3G is connected, why can't I see the SIM status change?

A: You have to restart the router to see the status. It is best to remove the SIM card when the router is OFF.

---

# Appendix C: Specifications

**Note: Specifications are subject to change without notice.**

<b>Physical</b>	
WLAN	802.11 b/g/n (2x2 MIMO)
Cellular modem	Embedded, 3GPP Rel 9, LTE FDD/eHRPD/EVDO/CDMA
Dimensions (LxWxH, mm)	160 x 94 x 44
Weight (g)	474
<b>Interface</b>	
Reset Button	Yes
RJ45 Ports	2 x RJ-45, 10/100 LAN ports
DC Power Jack	12V or 24V, accepting 9-32 V voltage swing
SIM slot	Embedded SIM as default, also 1 x SIM slot for external plug in for back up
USB Port	1 x USB port, for USB client device plug in only. K530S serve as USB host.
<b>Connectivity and Data Speed</b>	
4G LTE Band	Band 2, Band 4, Band 5, Band 12
LTE Data Rate	FDD Downlink up to 100Mbps, Uplink up to 50Mbps
LTE Bandwidth	Up to 20 MHz
3G EVDO/CDMA Band	BC0, BC1
WLAN	802.11 b/g/n, 2x2 MIMO



<b>Antenna</b>	
Cellular embedded main antenna	No
Cellular embedded diversity antenna	No
Cellular external main antenna port	Yes SMA type
Cellular external diversity antenna port	Yes SMA type
WiFi antenna	No Embedded
WiFi external antenna port	2 x SMA ports
GPS antenna port	Yes SMA type, supporting 3.3V DC Active Antenna
<b>Router Features</b>	
Routing	Static Routing, Dynamic Routing (RIP, BGP, OSPF)
Security	Multiple VPN pass-through (IPSec, PPTP, L2TP), Stateless and SPI Firewall
NAT-NAPT	Single Port Forwarding, Port Range Forwarding, Port Range Triggering, Port Filtering, IP Filtering, DMZ, UPnP, Multicast Pass-Through
VPN	IPSec, SSL
DNS	DNS Agent, DDNS
Other features	IPv4 and IPv6, TCP, UDP, ICMP, ARP, DHCP Server/Client, HTTP/HTTPS, NTP, ALGs

<b>Wireless LAN</b>	
802.11b data rate	1/2/5.5/11 Mbps
802.11g data rate	Up to 54 Mbps
802.11n data rate	Up to 300 Mbps
Security Types	WPA/WPA2 AES/TKIP Encryption, WPA/WPA2 PSK, WPA/WPA2 Enterprise, None/64/128 bits WEP Encryption, open system authentication.
Device Unique Default Encryption Key	Such unique key is linked to IMEI address of the device
Channel Selection	Auto or Manual
Other features	SSID broadcast disable, Dual SSID, Access control (MAC filtering), WLAN on/off software switch.
<b>Status Indication</b>	
LED Display	6 x LEDs: #1 cellular technology (Blue: LTE, Green: EVDO/CDMA, Red: SIM error or service failure) #2 signal strength (tri-color) #3 LAN 1 #4 LAN 2 #5 GPS #6 WiFi
<b>Software Features</b>	
Web Graphic User Interface (GUI)	Yes, Browser supported: IE, Firefox, Safari, Chrome
Web Graphic User Interface (GUI) Language Support	English
Connection Status in Web Graphic User Interface (GUI)	Network name, Signal strength, Roaming indication, Radio technology, Connection status, Connection time, Connection Statistics.
Connection management	Connection on demand, Connection when available, Auto APN matching with USIM , APN database update through browser-based Graphic User Interface (GUI), APN profile, PIN management, Preferred radio NW type selection

System protection	Password protected administrator and user access authority (provisioning, configuration, authentication).
GNSS	Supports GPS and Glonass composite location data for remote server and local access
Support FW version upgrade	Yes
Device Management	TR-069, OMA-DM, Remote Graphic User Interface (GUI) Log-in
<b>Accessories</b>	
Power Adapter	Input: 100to240V, 50to60Hz AC; Output: 12V DC
<b>Environment</b>	
Operation Temperature	-20°C to 70°C (-4°F to 158°F)
Storage Temperature	-40°C to 80°C (-40°F to 185°F)
Operating Humidity	10% to 85% Non-Condensing
Storage Humidity	5% to 90% Non-Condensing
<b>Certification &amp; Conformance</b>	
	RoHS, IP64, MIL 810-G, FCC, Sprint Certification

---

# ***Appendix D: Important Safety Information and Glossary***

## **Europe – EU Declaration of Conformity**



### **European Union Notice**

Products with CE marking comply with the R&TTE Directive (99/5/EC), the EMC Directive (2004/108/EC), and the Low Voltage Directive (2006/95/EC) issued by the Commission of the European Community.

Compliance with these directives implies conformity to the following European Norms (in parentheses are the equivalent international standards).

### **EN 60950-1 (IEC 60950-1)**

Safety of Information Technology Equipment.

### **EN 300 328**

Electromagnetic compatibility and Radio spectrum Matters (ERM); Wideband Transmission systems; data transmission equipment operating in the 2.4 GHz ISM band and using spread spectrum modulation techniques.

### **EN 301 489-24**

Electromagnetic compatibility and Radio spectrum Matters (ERM); Electromagnetic Compatibility (EMC) standard for radio equipment and services; Part 24: Specific conditions for IMT-2000 CDMA direct spread (UTRA) for mobile and portable (UE) radio and ancillary equipment.

### **ETSI EN 301 511**

Global system for mobile communications (GSM); Harmonised EN for mobile stations in the GSM 900 and GSM 1800 bands, covering essential requirements of article 3.2 of the R&TTE directive (1995/5/EC).

### **ETSI EN 301 489-1**

Electromagnetic compatibility and Radio spectrum Matters (ERM); Electromagnetic Compatibility (EMC) standard for radio equipment and services; Part 1: Common technical requirements.

### **ETSI EN 301 489-7**

Electromagnetic compatibility and Radio spectrum Matters (ERM); Electromagnetic Compatibility (EMC) standard for radio equipment and services; Part 7: Specific conditions for mobile and portable radio and ancillary equipment of digital cellular radio telecommunications systems (GSM and DCS).

---

### **ETSI EN 301 489-17**

Electromagnetic compatibility and Radio spectrum Matters (ERM);  
Electromagnetic Compatibility (EMC) standard for radio equipment and services;  
Part 17: Specific conditions for 2.4 GHz wideband transmission systems.

### **ETSI EN 301 908-1 & -2**

Electromagnetic compatibility and Radio spectrum Matters (ERM); Base Stations (BS),  
Repeaters and User Equipment (UE) for IMT-2000 Third Generation cellular networks;  
Part 1: Harmonised EN for IMT-2000, introduction and common requirements,  
covering essential requirements of article 3.2 of the R&TTE Directive.

### **EN 50385**

Product standard to demonstrate the compliance of radio base stations and fixed  
terminal stations for wireless telecommunication systems with the basic restrictions or  
the reference levels related to human exposure to radio frequency electromagnetic  
fields (110 MHz - 40 GHz) - General public.

## **Federal Communication Commission Interference Statement**

15.21

You are cautioned that changes or modifications not expressly approved by the part  
responsible for compliance could void the user's authority to operate the equipment.

15.105(b)

### **Federal Communications Commission (FCC) Statement**

This equipment has been tested and found to comply with the limits for a Class B  
digital device, pursuant to part 15 of the FCC rules. These limits are designed to  
provide reasonable protection against harmful interference in a residential installation.  
This equipment generates, uses and can radiate radio frequency energy and, if not  
installed and used in accordance with the instructions, may cause harmful  
interference to radio communications. However, there is no guarantee that  
interference will not occur in a particular installation. If this equipment does cause  
harmful interference to radio or television reception, which can be determined by  
turning the equipment off and on, the user is encouraged to try to correct the  
interference by one or more of the following measures:

- Reorient or relocate the receiving antenna.
- Increase the separation between the equipment and receiver.
- Connect the equipment into an outlet on a circuit different from that to which the  
receiver is connected.
- Consult the dealer or an experienced radio/TV technician for help.

---

**This device complies with Part 15 of the FCC Rules. Operation is subject to the following two conditions:**

- 1) This device may not cause harmful interference and
- 2) This device must accept any interference received, including interference that may cause undesired operation of the device.

**FCC RF Radiation Exposure Statement:**

1. This Transmitter must not be co-located or operating in conjunction with any other antenna or transmitter.

2. This equipment complies with FCC RF radiation exposure limits set forth for an uncontrolled environment. This equipment should be installed and operated with a minimum distance of 20 centimeters between the radiator and your body.

---

## Glossary

**2G:** Second-generation mobile networking technology. Represents a switchover from analog to digital; most 2G networks use GSM.

**3G:** Third-generation mobile networking technology that enables simultaneous transfer of voice and non-voice data; most 3G networks use WCDMA.

**3.5G:** A more recent standard of mobile networking technology; generally uses HSDPA.

**3.75G:** A more recent standard of mobile networking technology; generally uses HSUPA.

**4G:** A more recent standard of mobile networking technology; generally uses LTE.

**APN (Access Point Name/Network):** Provides GPRS routing information. Consists of:

Network ID: Identifies the external service requested by a GPRS user.

Mobile network operator ID: Specifies routing information.

**ARFCN (Absolute Radio Frequency Channel Number):** The specific ID numbers for all radio channels used in cellular mobile communications.

**bps (bits per second):** How data flow is measured.

**CHAP (Challenge Handshake Authentication Protocol):** CHAP identifiers are changed frequently and authentication can be requested by the server at any time.

**DNS (Domain Name System):** Helps route network traffic by making the addressing process more user-friendly.

**DHCP (Dynamic Host Configuration Protocol):** How devices obtain IP addresses from a server.

**DUN (Dial-Up Network):** Windows component that enables online access via a modem.

**EDGE (Enhanced Data GSM Environment/Enhanced Data for Global Evolution):** Advanced GPRS that delivers multimedia and other data needing greater bandwidth at up to 237 kbps.

**eHRPD (Evolved High Rate Packet Data):** An upgrade of the existing *HRPD (High Rate Packet Data)* and EV-DO (Evolution-data Optimized) network technology to allow smooth transitioning from 3G mobile network technology to 4G LTE network technology.

**GPRS (General Packet Radio Service):** Delivers data in packets at up to 86 kbps.

**GSM (Global System for Mobile Communications):** The most popular cellular network, mostly operates in 850-900 or 1800-1900 MHz; the primary 2G system.

**HSDPA (High Speed Downlink Packet Access):** Advanced WCDMA that delivers downlink bandwidth intensive data at up to 7.2Mbps; typically associated with 3.5G.

---

**HSUPA (High Speed Uplink Packet Access):** Advanced WCDMA that delivers uplink bandwidth intensive data at up to 5.76Mbps; typically associated with 3.75G.

**HSPA+ (High Speed Packet Access +):** This is also known as HSPA Evolved, is the next step and is more focused on delivering data services enabling speeds of up to 42Mbps in the downlink and 11Mbps in the uplink.

**IMEI (International Mobile Equipment Identity):** A number unique to each GSM/UMTS device that can be used block network access by a stolen mobile device.

**IP (Internet Protocol):** Routes packets over a network.

**IPSec (Internet Protocol Security):** Security implementation of IP communications by authenticating and encrypting each IP packet during network communication.

**Kbps (Kilobits per second):** A data flow measure; 1024 bits/second.

**LAN (Local Area Network):** A data network with limited range but good bandwidth.

**Load Balance:** A method for distributing network loads across different networks to optimize network traffic flow and increase network reliability.

**LTE (Long Term Evolution):** High-speed mobile communication standard based on the GSM/EDGE and UMTS/HSPA network technologies. LTE provides downlink peak rates up to 300 Mbit/s and uplink peak rates up to 75 Mbit/s.

**Mbps (Megabits per second):** A data flow measure; 1,048,576 bits/second.

**MDN (Mobile Directory Number):** The telephone number of the mobile device. In other words, it is the directory number that is assigned to a mobile subscriber.

**MSID (Mobile Station Identification):** The identification number for the mobile station. The *MSID* can be a *MIN (Mobile Identification Number)* or *IMSI (International Mobile Subscriber Identity)*.

**MSL (Maximum Segment Lifetime):** The maximum amount of time (arbitrarily defined as 2 minutes) that a TCP segment can exist in the internetwork system.

**PAP (Password Authentication Protocol):** The difference between PAP authentication and a manual or scripted login, is that PAP is not interactive. The username and password are entered in the client's dialing software and sent as one data package as soon as the modems have established a connection, rather than the server sending a login prompt and waiting for a response.

**PPP (Point-to-Point Protocol):** An internet connection method.

**PIN (Personal Identity Number):** Four to eight digital numbers SIM card security code; allows access to the carrier's network.

**Rx:** Shorthand for Reception.

**SIM (Subscriber Identity Module):** A small card that contains key mobile device identification, subscription and contact information.

**Tx:** Shorthand for Transmission.



---

**WCDMA (Wideband Code Division Multiple Access):** Advanced EDGE that supports 384kbps data flow. Most 3G networks use this standard, the same as UMTS.

**UAM (Universal Access Method):** A method to allow WiFi access to a wireless network while roaming. Using a regular web browser, the roaming customer enters a login page and provides user information (usually username and password) to access the network.