



E500A/E500P Series Installation Guide

Table of Contents

ABOUT THIS MANUAL.....	4
PRODUCT OVERVIEW	5
FEATURES	5
PACKAGE CONTENTS	5
PARTS AND FUNCTIONS	6
NOTICE BEFORE INSTALLATION	7
IMPORTANT INSTALLATION CONSIDERATIONS	8
INSTALL THE SIM CARD.....	10
MOUNTING AND INSTALLATION	11
Mount Assembly package.....	11
Wall-mount Assembly.....	12
Pole-mount Assembly	13
GETTING STARTED	15
INSERT THE ETHERNET CABLE	15
ASSEMBLE THE OPTIONAL WATER-PROOF RJ-45 JACK.....	16
GROUNDING THE CPE	17
CONNECT TO COMPUTERS	18
ADJUSTING CPE POSITION	19
Horizontal angle adjustment.....	19
Vertical angle adjustment	19
USING WEB-BASED MANAGEMENT	20
CONFIGURE IP ADDRESS [FOR BRIDGE MODE ONLY].....	20
LOGIN.....	22
BASIC NETWORK SETTINGS.....	24
Configure Mobile Internet Settings	24
Configure CPE IP Settings	25
Configure DHCP Services	26
Configure CPE Time.....	27
STATUS INFORMATION	28
View Internet Connection Info	28
View CPE Info	29
View Traffic Info.....	29
SIM/PIN SETTINGS.....	30
Configure PIN	30
Unlock SIM.....	31
SECURITY SETTINGS	32
ADMINISTRATOR SETTINGS	33
Change Web Management Password	33

Enable Remote Access	33
Manage LED Light	34
Select Operation Mode.....	34
ADVANCED DIAGNOSIS	35
Enable SysLog	35
View System Log	36
Use Ping Test.....	36
Use Traceroute Test	36
SYSTEM MAINTENANCE	37
Backup Configuration	37
Restore Configuration	37
Update APN	38
Restore Factory Defaults.....	38
Upgrade CPE Firmware	38
NAT SETTINGS.....	39
Configure Single Port Forwarding	39
Configure Port Range Forward	40
Configure Port Range Trigger	41
Enable UPnP	42
Configure DMZ.....	42
ENGINEERING MODE	43

APPENDIX 44

FAQ.....	44
TROUBLESHOOTING.....	45
SPECIFICATIONS	46
SAFETY INFORMATION.....	48
FEDERAL COMMUNICATION COMMISSION INTERFERENCE STATEMENT.....	49

About this Manual

The content of this User Manual has been made as accurate as possible. However, due to continual product improvements, specifications and other information are subject to change without notice.

Product Overview

Congratulations on your purchase of this LTE outdoor CPE.

With this LTE (Long Term Evolution) CPE (which is also known as 4G CPE), you can share high speed mobile broadband connectivity in a wide range of computing environment. Before you begin using the LTE outdoor CPE, read this chapter to familiarize yourself with the device.

Features

- Embedded high gain directional antenna
- IP66 protection against dust and water
- Easy configuration based on Web Interface
- Provide 10 – 30dB more coverage gain compared to indoor CPE
- Support Passive Power over Ethernet.
- Easy installation and use

Package Contents

The following items come with your package. If any of them is damaged or missing, please contact your retailer.

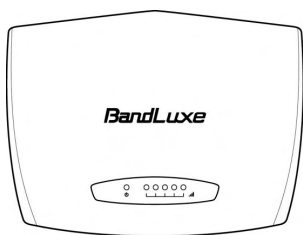

LTE Outdoor CPE

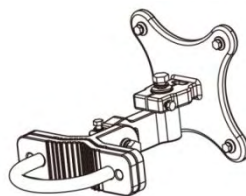

Mounting bracket



Optional:
Plug head water
resistant kits (RJ-45)

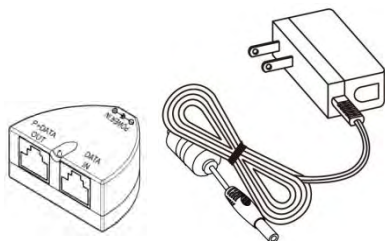

Passive PoE adapter
(12V, E500A series)

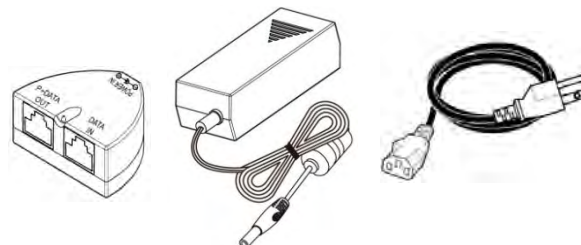

Passive PoE adapter
(48V, E500P series)

NOTE

- The pictures are for reference only, actual items may slightly differ.

Parts and Functions

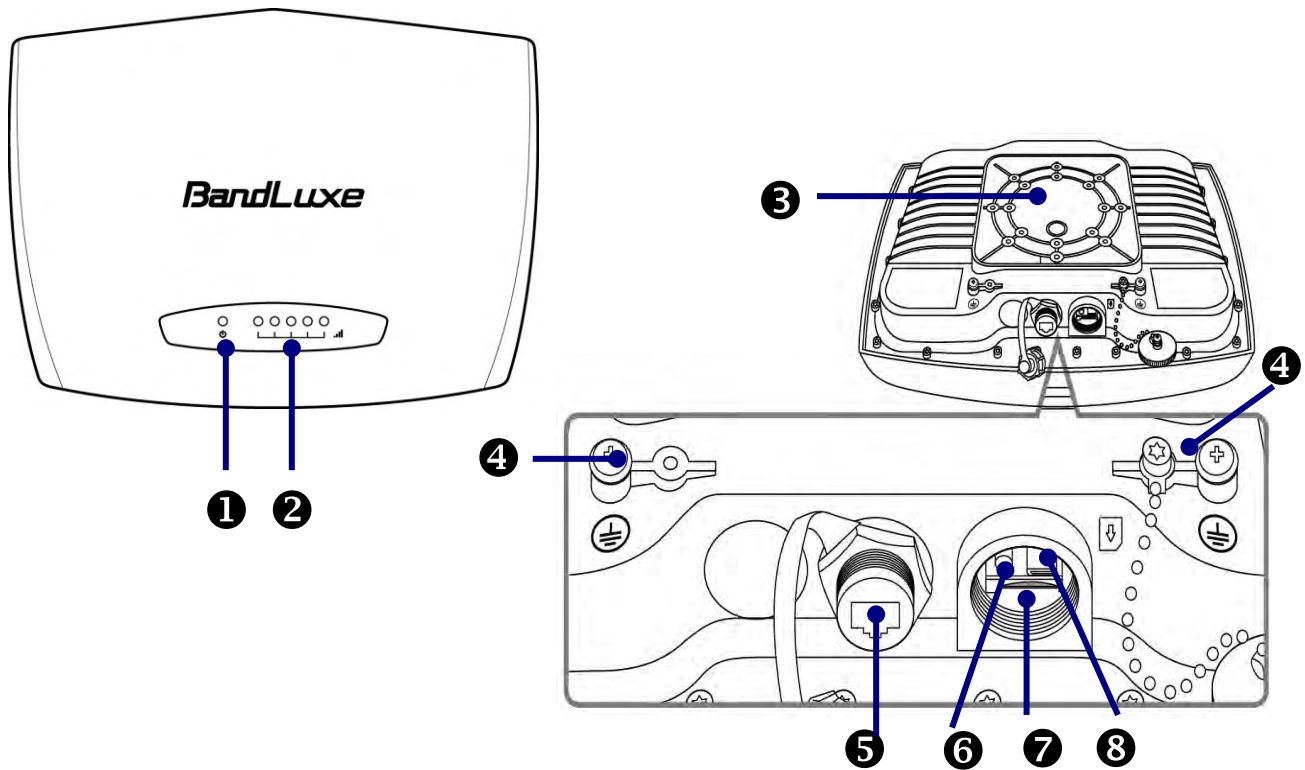

No.	Item	Description
1	Power	Blue LED lights up when the power is on.
2	Signal strength	More lighted LEDs indicate stronger signal.
3	Mount base	Attach the mount bracket.
4	Earth ground terminal	Use a spring washer and an M4x8L screw to ground and protect CPE from lightning. See "Grounding the CPE" on page 16 for more details.
5	Ethernet port	Connect to a computer/ Passive PoE using an Ethernet cable.
6	Reset button	<ul style="list-style-type: none"> ❖ Short press to restart the device. ❖ Long press for 5 seconds to reset the settings to the factory default settings.
7	SIM card slot	Insert the SIM card.
8	USB port	For technicians use only.

Notice before installation

Choose a solid and safe place (Wall or Pole) for CPE installation

1. Choose the best location of the house and the orientation of the CPE to get the strongest signal reception from base station.
2. The ambient temperature for E500A and E500P series must be within:
E500A series: -10°C to 55°C
E500P series: -40°C to 55°C

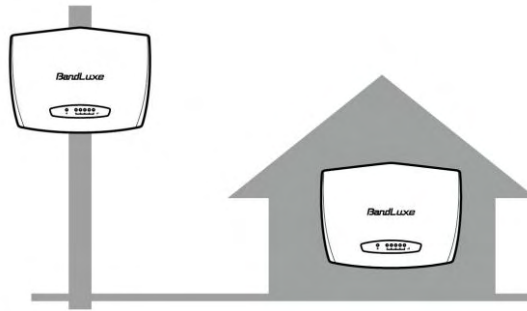

NOTE

To have better reception, there are few things you could considerate before installation. Please see "Important Installation Considerations" on page 8 for more details.

Prepare two Ethernet cables

Be sure that one of the cables used is an outdoor grade CAT 5e (or above) Ethernet cable type and the length of the cables are adequate to reach the location of the CPE and indoor PPOE are.

Prepare wrenches

Prepare two adjustable wrenches or four combination wrenches. (size: 13mm x 2, 8mm x 1, and 19mm x 1)

Important Installation Considerations

Before installing the outdoor CPE, consider the appropriate location, clearance, and device orientation.

Location and Cable wiring

1. Consult your operator to find the best location and angle for getting the strongest signal from the base station.
2. Do a walking test around the house to find the best spot with the strongest **signal if you don't obtain related information** from operator.
3. Mount the CPE at the highest possible location with a clear view of the base station signal source. Buildings or other obstructions will affect the quality of the signal you receive.
4. Keep a distance as possible from other devices that may cause interference.
5. Check if you can route the cable through the available ventilation holes to avoid unnecessary drilling and waterproofing the wall.

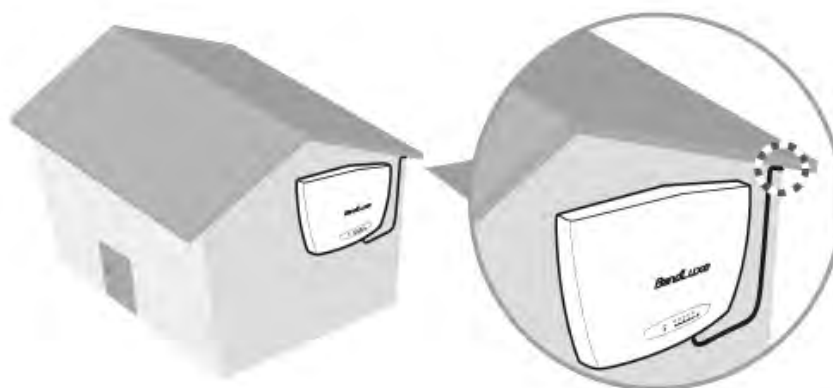

6. Disconnect the power cord first before mounting the CPE. Otherwise this may result in personal injury due to electric shock.

Mounting

1. Choose a solid wall/ground to mount the CPE.
2. Mount on a wall/pole that can sustain the CPE dimensions and weight.
3. Mount upright on a vertical surface.

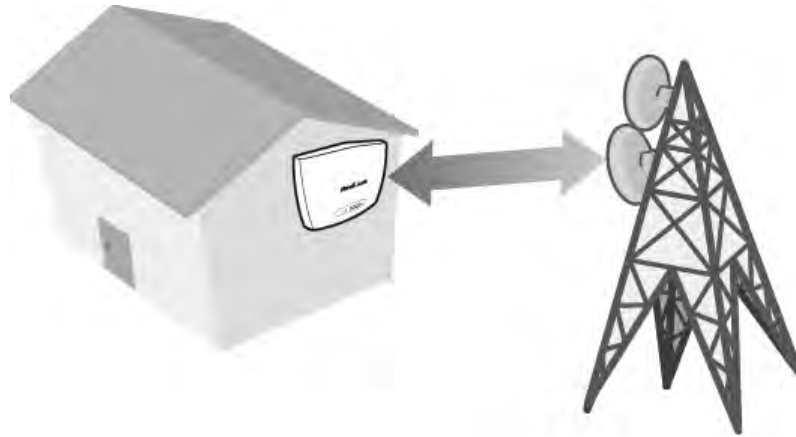

Position Adjustment

1. The CPE must be directed towards the nearest base station. By pointing the CPE in the proper direction ensures that you receive the strongest signal.
2. Fine tune the signal by adjusting the orientation horizontally or vertically to increase the CPE signal strength.
3. To verify the signal strength level:
 - Check the LEDs on the front panel - more lighted LEDs indicates stronger signal.
 - Access the web management and go to **Basic Mode > Status > Mobile Internet > Signal Quality** to view the Rx signal strength.

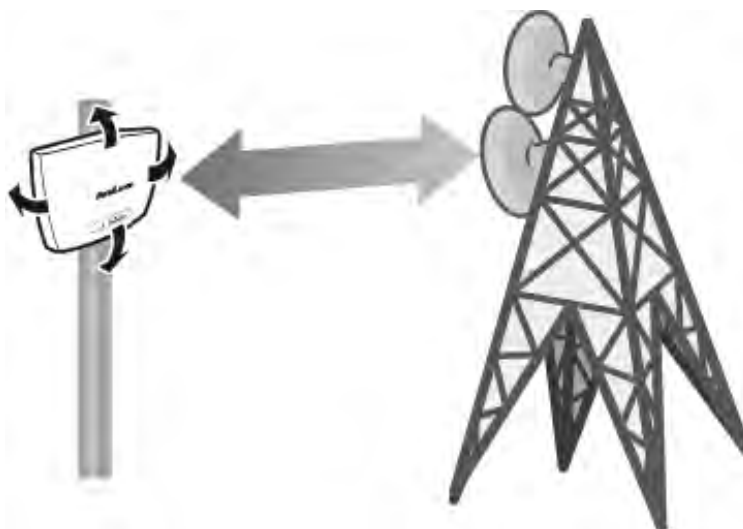

Install the SIM card

This CPE is specially designed for the 4G LTE network.

NOTE

Check the availability of service and plan rates of data connections with your network service provider.

1. Unscrew the SIM card slot.

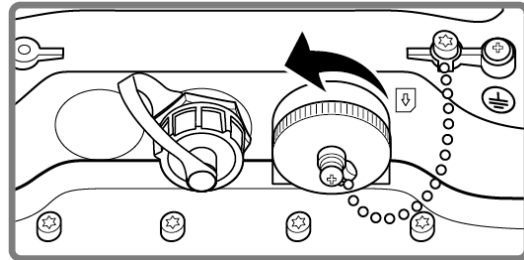

2. Insert a valid SIM card into the SIM card slot.
Push it fully until it clicks into place.

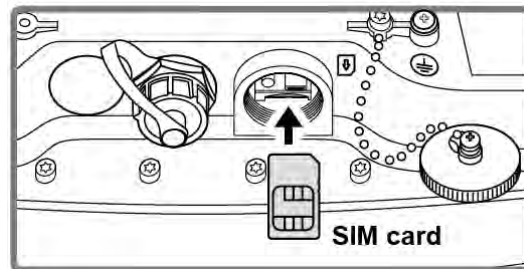

3. Screw the cap back on tightly.

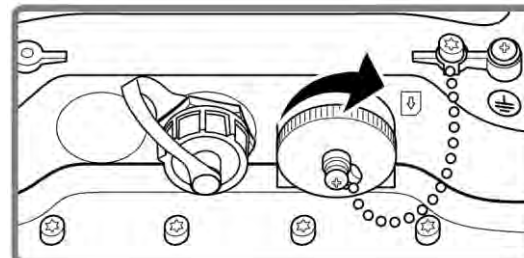

Remove the SIM card

Push to eject the SIM card from the slot.

NOTE

- Once the SIM is reinserted, you must restart the CPE to read the SIM card properly.

Mounting and Installation

This CPE is weatherproof and designed for outdoor use. You can mount it to a wall or to a pole.

Mount Assembly package



A
Kit-1
Quantity: 1



B
Kit-2
Quantity: 1



C
Hex Head Bolt
(M8x50mm)
Quantity: 2



D
M8 Spring Washer
Quantity: 3

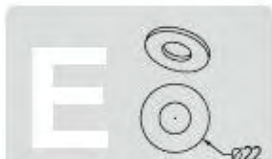

E
Washer M8x22
(OD) mm
Quantity: 2



F
M8 Hexagon Nuts
Quantity: 2



G
Hex Head Bolt
(M5x35mm)
Quantity: 2



H
Spring Washer
(M5)
Quantity: 6



I
Kit-3
Quantity: 1



J
Washer (M8)
Quantity: 1



K
Hex. Head Bolt
(M5x20mm)
Quantity: 4



L
Washer (M5)
Quantity: 4



M
Kit-4
Quantity: 1



N
1/2" U Bolt DN63
Quantity: 1



O
M13 Washer
Quantity: 2



P
M13 Spring
Washer
Quantity: 2



Q
1/2 Hexagon Nuts
Quantity: 2

NOTE

- The illustrations are for reference only, actual items may slightly differ.

Wall-mount Assembly

1. Align the mounting bracket on the wall. Using the bracket as mounting template, mark the positions to drill the holes.
2. Assemble the bracket as shown in the illustration.

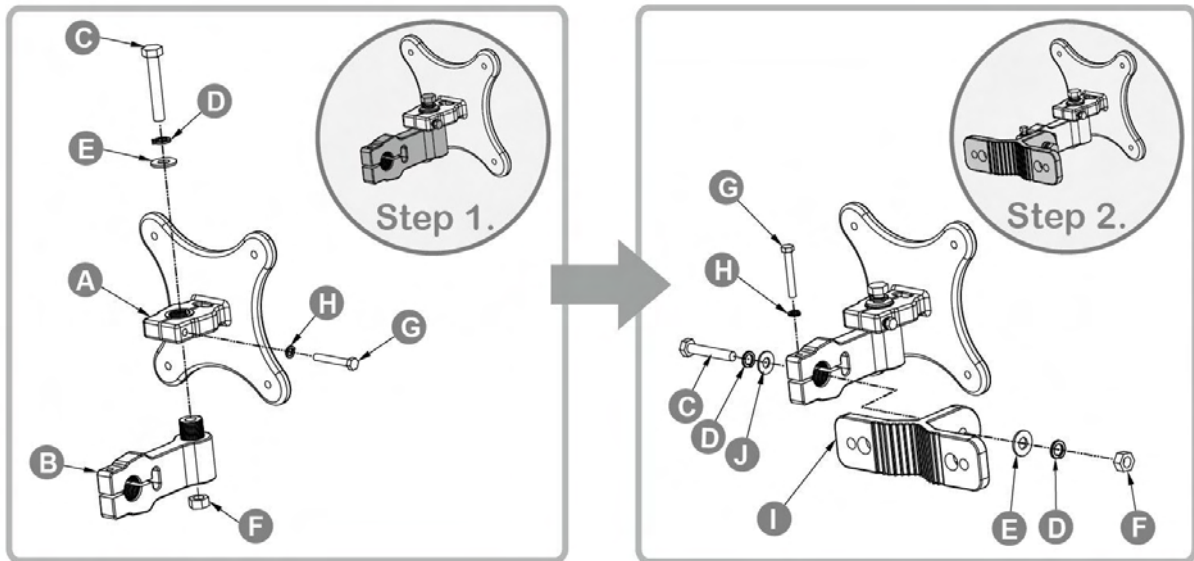

3. Attach the bracket to the back of the CPE.

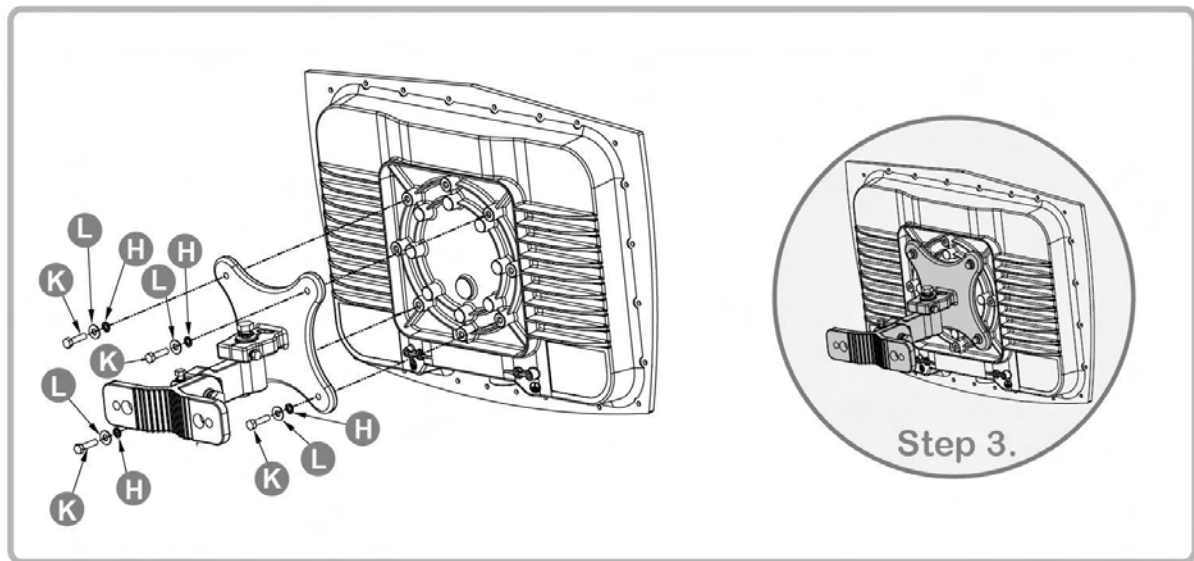

4. Hang the CPE to the wall and secure the bracket using the designated screws and washers.

Pole-mount Assembly

To mount the CPE to a pole, follow the steps below:

1. Assemble the mounting bracket as shown in the illustration.
2. Attach the bracket to the back of the CPE.

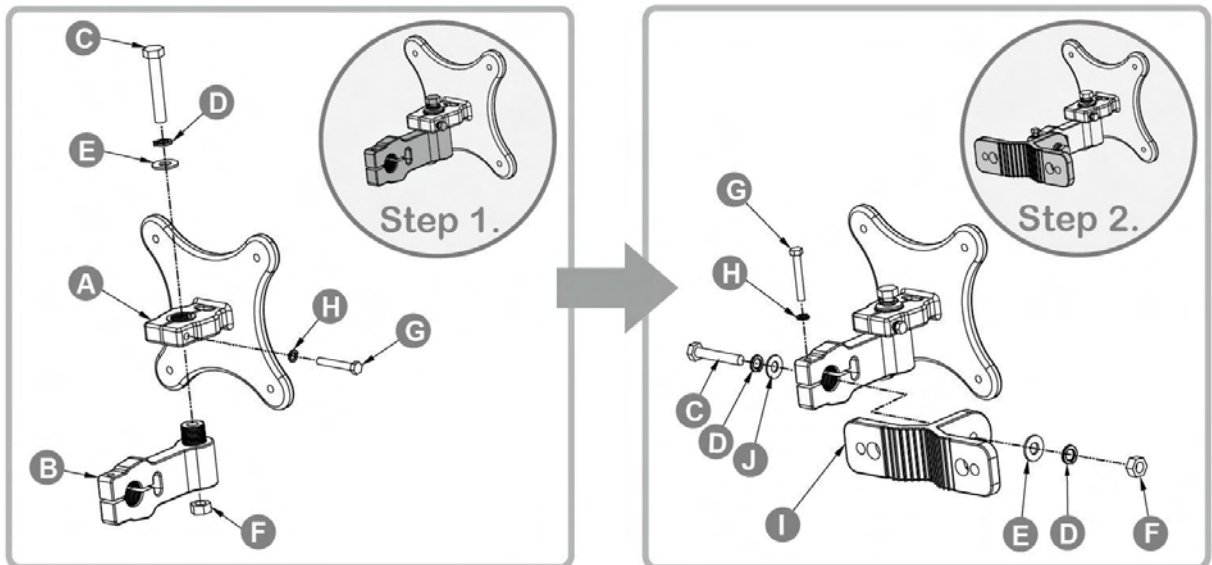

3. Attach the bracket to the back of the CPE.

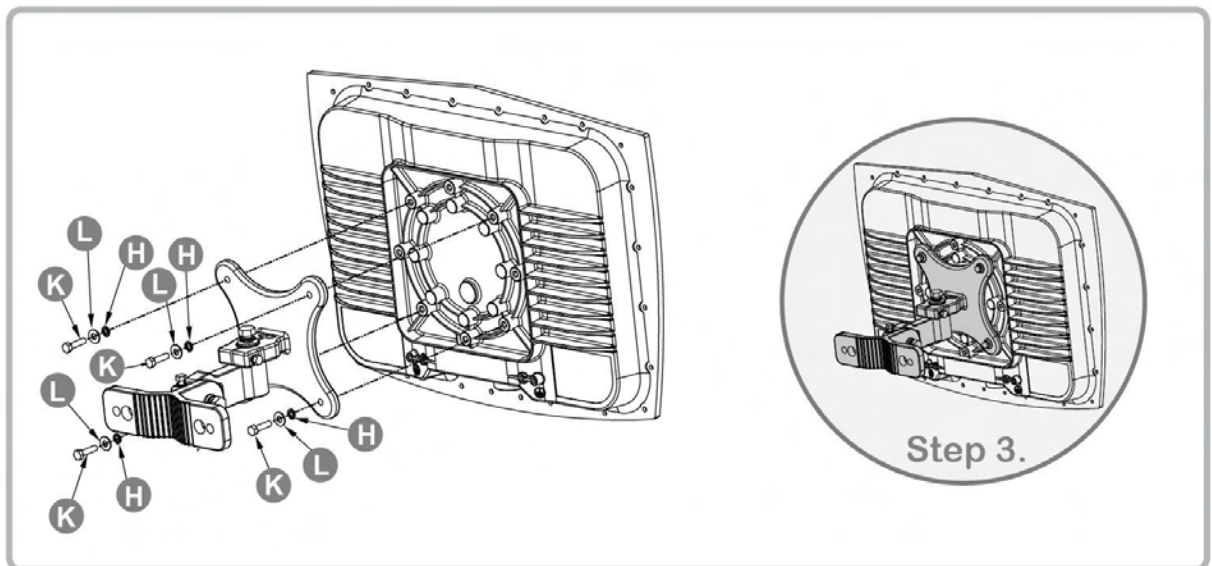

LTE Outdoor CPE

- Align a pole on the bracket and assemble the pole bracket as shown.

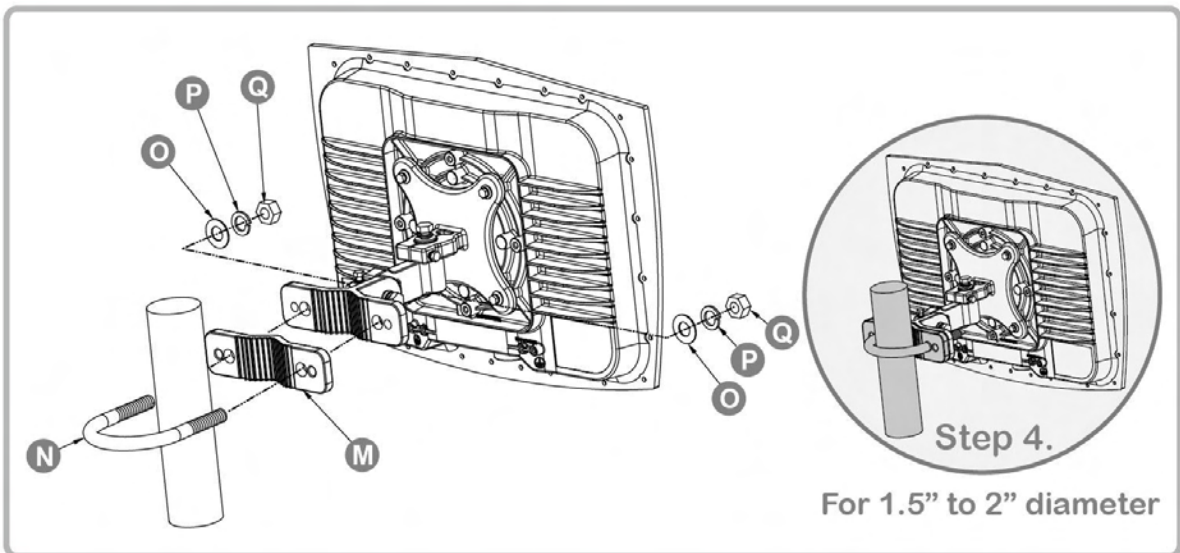
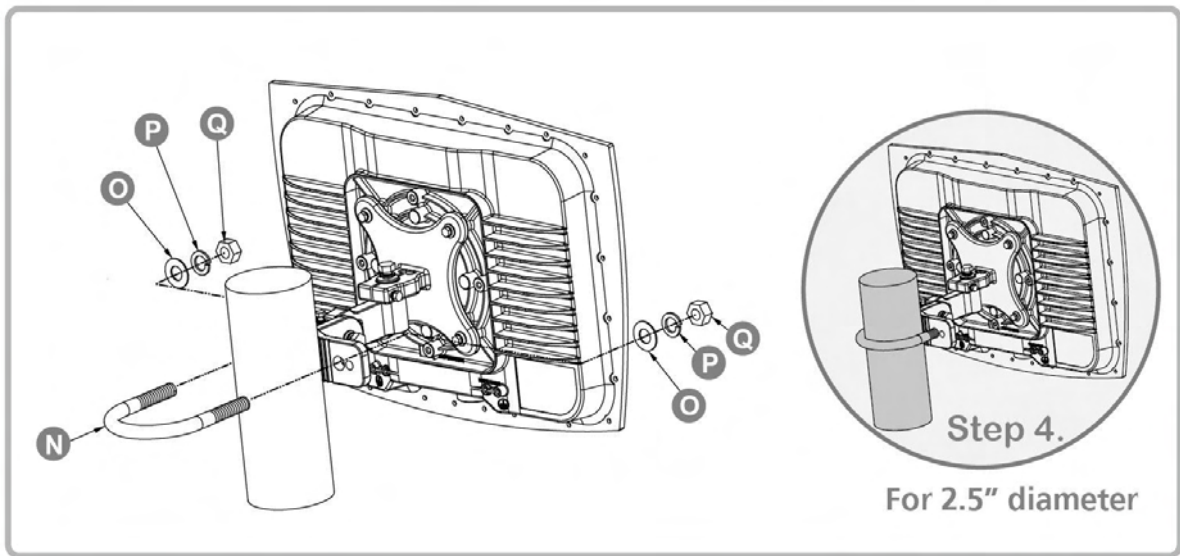

- Adjust the CPE position to an appropriate direction and secure the pole bracket using the designated screws and washers.

Getting Started

This chapter will guide you on how to use your outdoor CPE.

Insert the Ethernet Cable

Unscrew the Ethernet port and insert one end of the Ethernet cable into the CPE port.

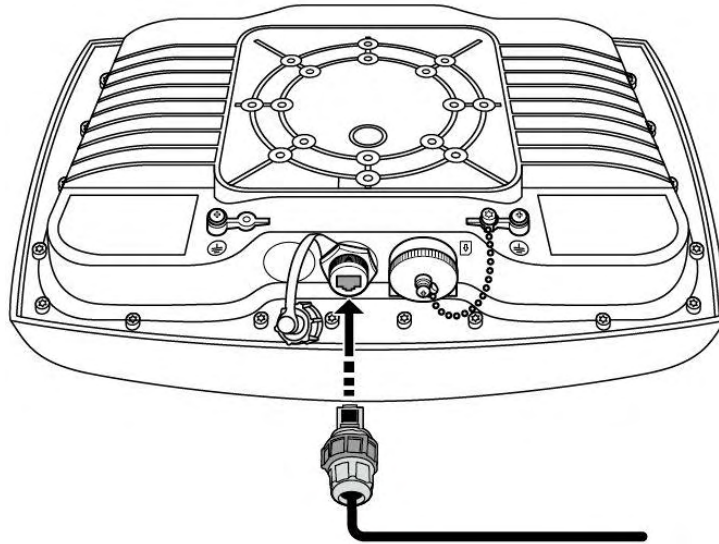

Note:

- To have best protection against dust and water, ethernet cable MUST be plugged with water-proof RJ-45 jack.

Assemble the Optional Water-Proof RJ-45 Jack

1. Unpack the RJ-45 water resistant kit.
2. Assemble one end of the Ethernet cable as shown in the illustration.

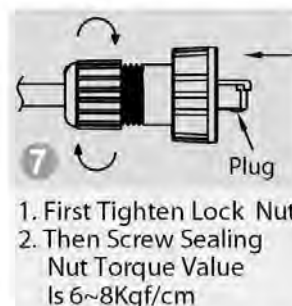
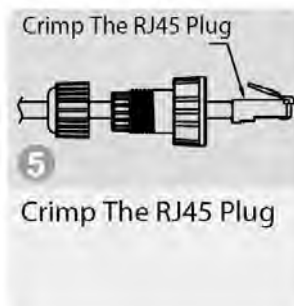
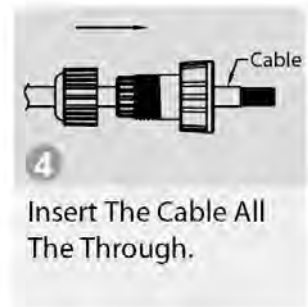
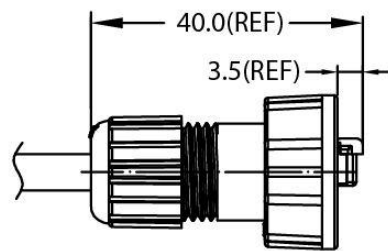
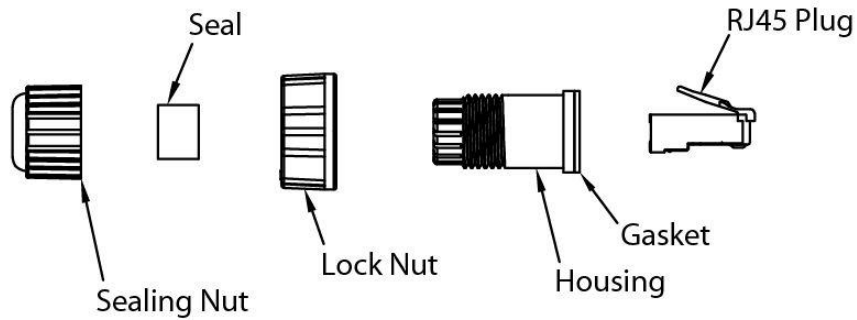

NOTE

- The Ethernet cable is not included in the package.

Grounding the CPE

For safety use, use the earth ground terminal to ground the CPE housing before making any connections.

You need the following:

- Spring washer
- M 4x8 L screw

NOTE

- The spring washer and M4x8L screw are not included in your package.

To ground the CPE:

1. Insert the washer to the M4x8L screw.
2. Attach the screw halfway into the earth ground terminal.
3. Insert the grounding cable under the washer.
4. Tighten the screw.

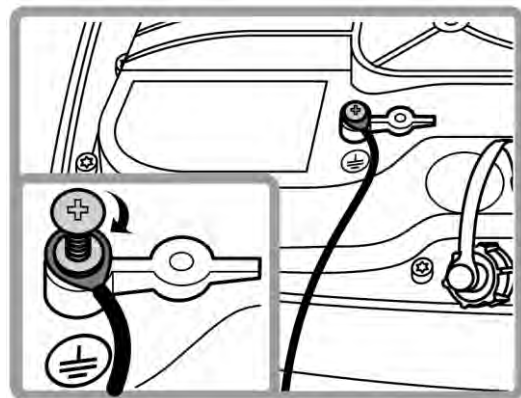

Connect to Computers

To use the Internet connection and configure the CPE settings, you must connect your CPE to a computer.

Prepare two Ethernet cables for connection.

1. Insert the other end of the Ethernet cable to "P+D OUT" port of the PoE adapter.
2. Connect another Ethernet cable to a Network Hub/Router or directly to PC/Laptop via PoE adapter ("Data/IN" port).
3. Plug the PoE adapter to an electrical outlet.

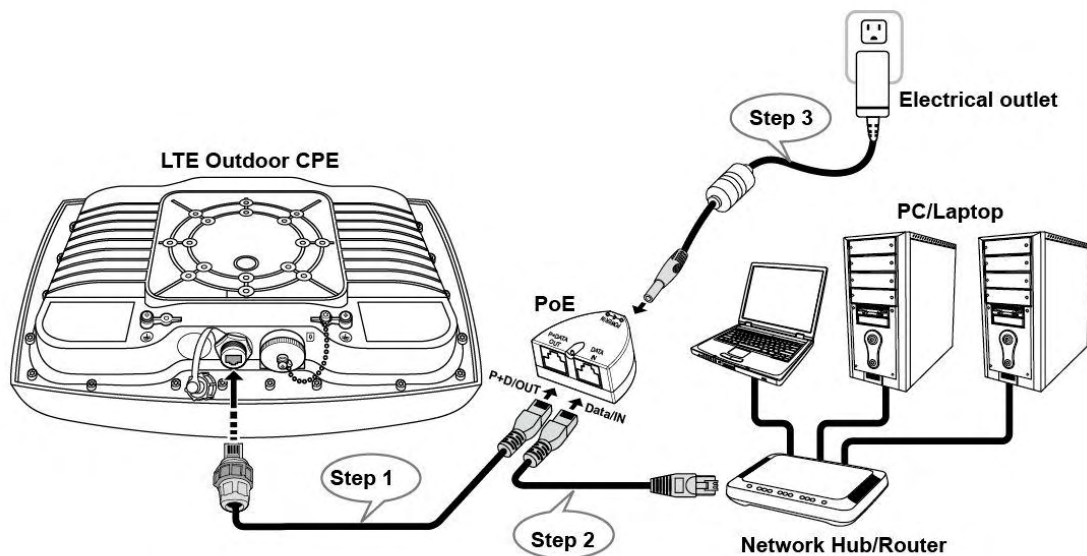

Using Passive PoE adapter (E500A series)

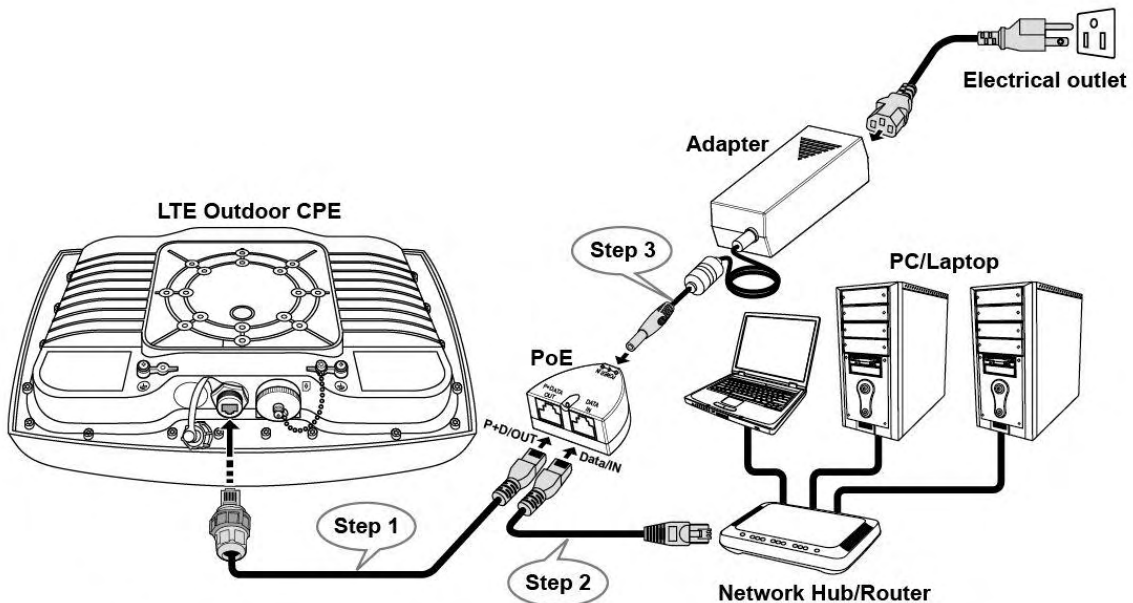

Using Passive PoE adapter (E500P series)

Adjusting CPE position

To get a better reception, fine tune the CPE orientation (horizontally or vertically) to have the best signal strength shown from LED or other test equipment.

Note:

- More lighted LEDs (on the front panel) indicate stronger signal.

Horizontal angle adjustment

1. Loose the top knob using the wrench as shown.
2. Swivel the device to the left or right to face the direction of the base station.
3. Secure the knob using the wrench after the position is fixed.

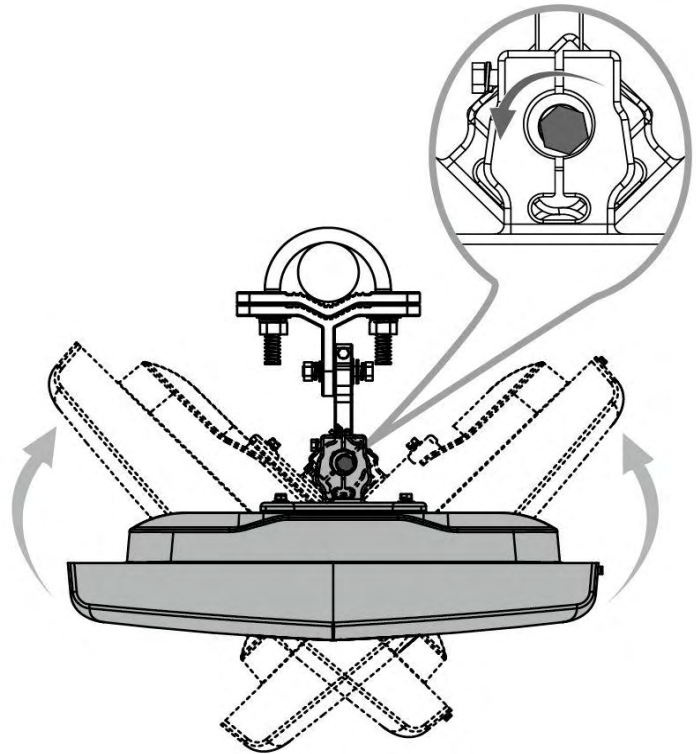

Vertical angle adjustment

1. Loose the side knob using the wrench as shown.
2. Adjust the device position up or down to face the direction of the base station.
3. Secure the knob using the wrench after the position is fixed.

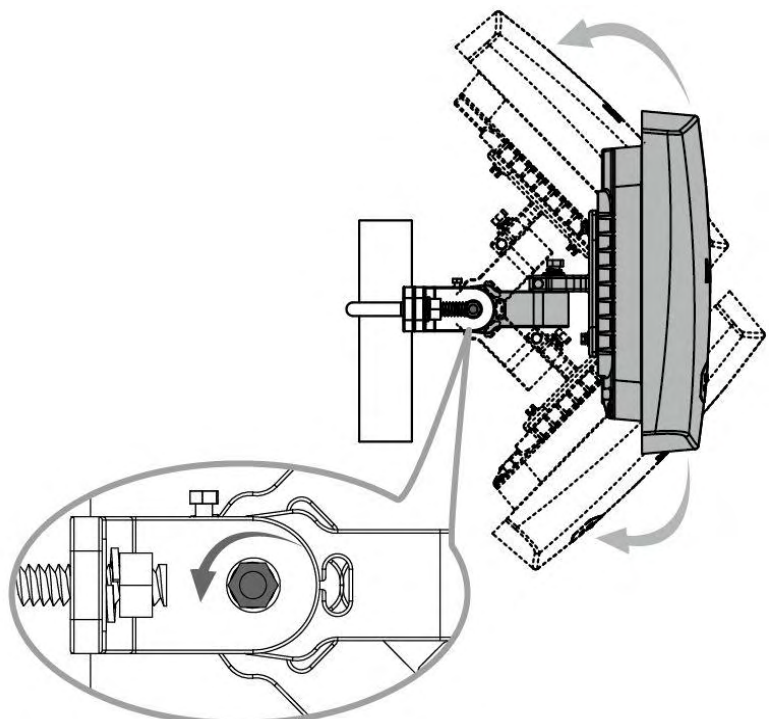

Using Web-based Management

This chapter will guide you on how to configure your CPE via the web-based utility.

Configure IP address [for Bridge mode only]

[Note]

- Configure IP address is not required under router mode.
Please go to “**Login**” directly.

Please follow below steps to configure IP address under bridge mode.

1. Go to **Control Panel > Network and Internet > Network and Sharing Center** to **Change adapter settings**.



2. Click the **Local Area Connection > Properties**.

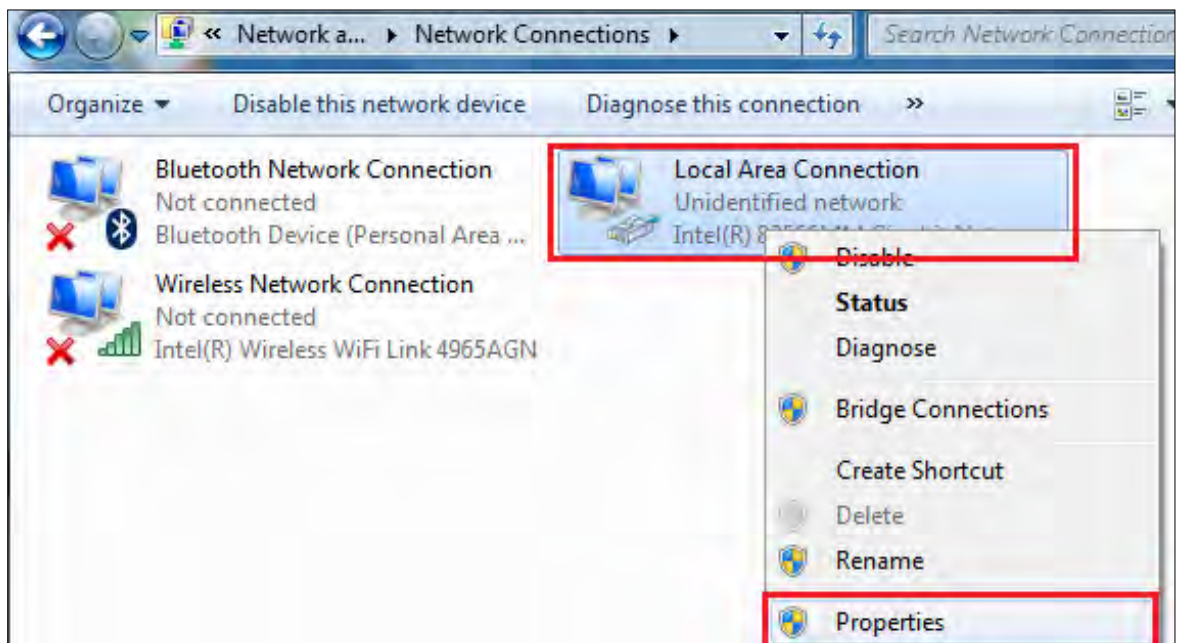

3. Choose **Internet Protocol Version 4 (TCP/IPv4)** then click **Properties**.

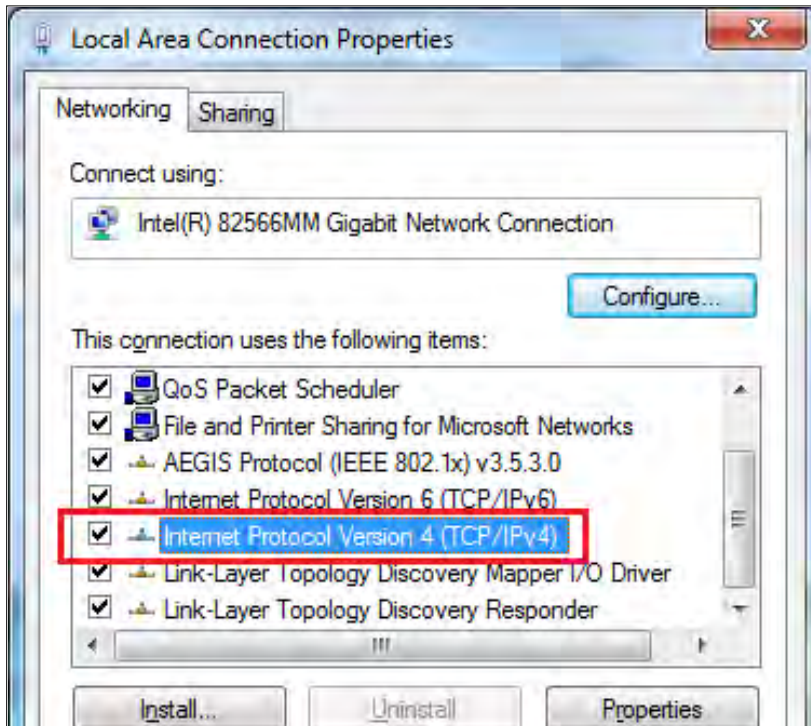

4. Enter the **IP address** as 192.168.168.X, **Subnet mask** as 255.255.255.0, and **Default gateway** as 192.168.168.168, **Preferred DNS server** from your ISP, then click **OK**.

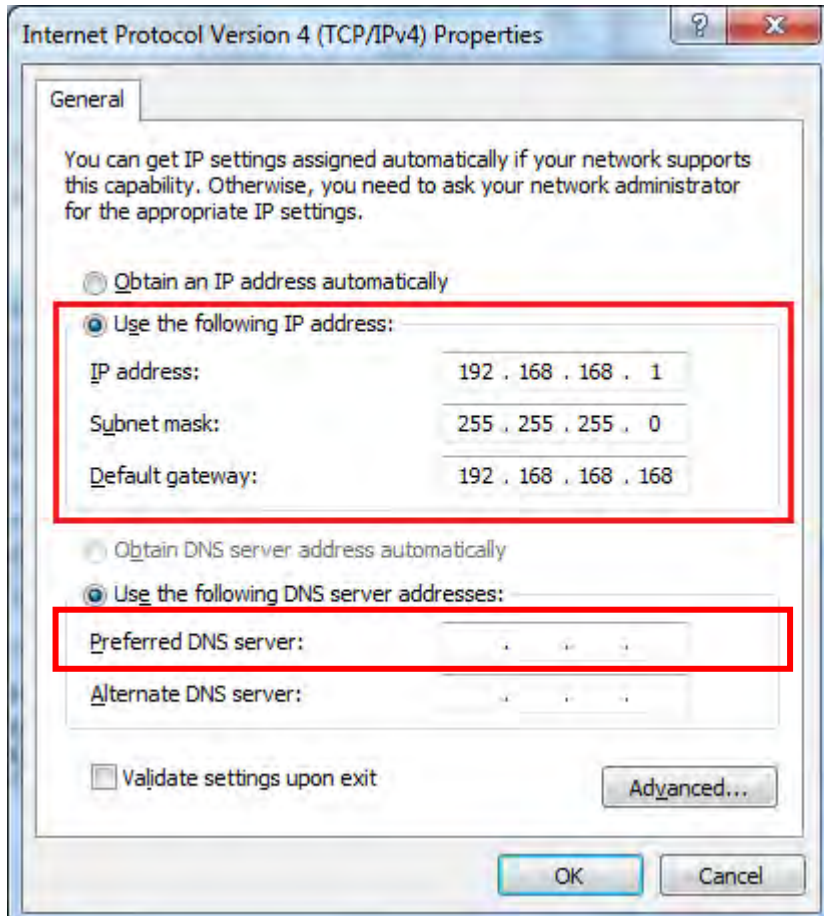

Login

1. Launch a web browser.
2. On the address bar, enter <http://192.168.168.168>, then press **Enter**.



3. On the opening screen, enter the username (**admin**) and password (**admin**).

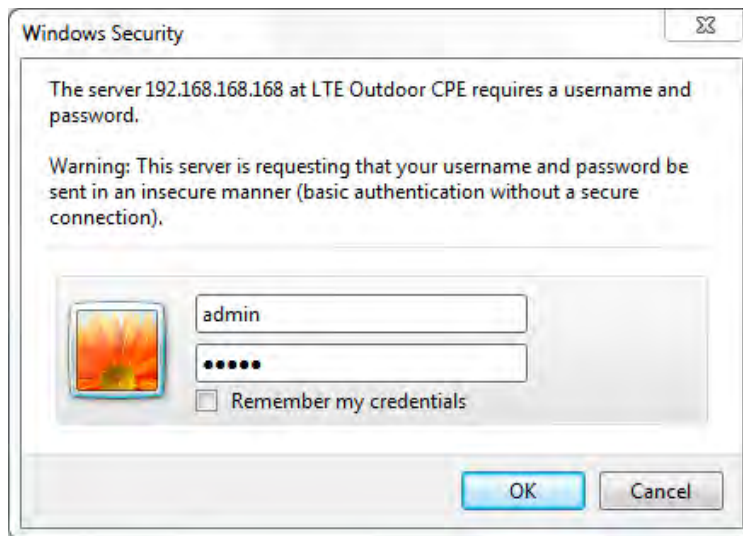

4. Click **OK** to login to the main screen.
5. Select preferred language, and click **Apply**.

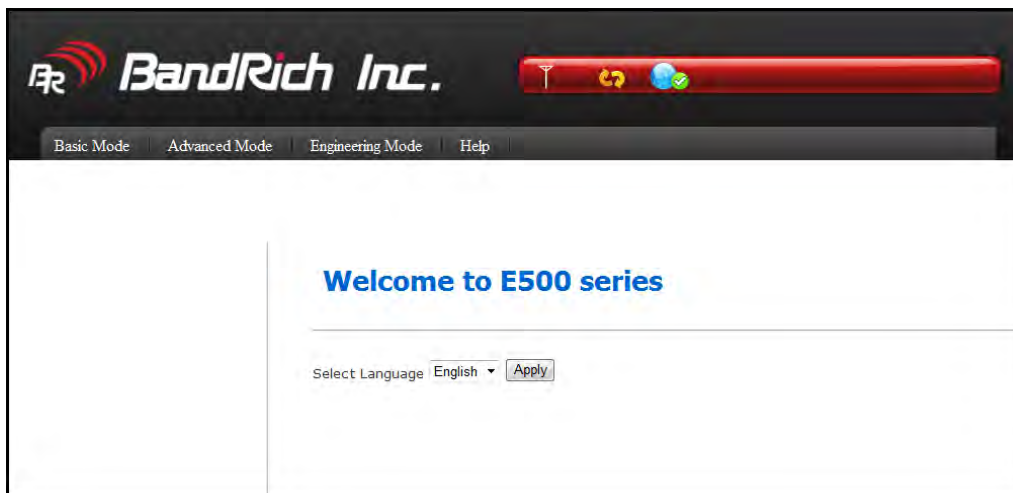

- Click one of the header tabs and click the left navigation submenu items to configure the system.

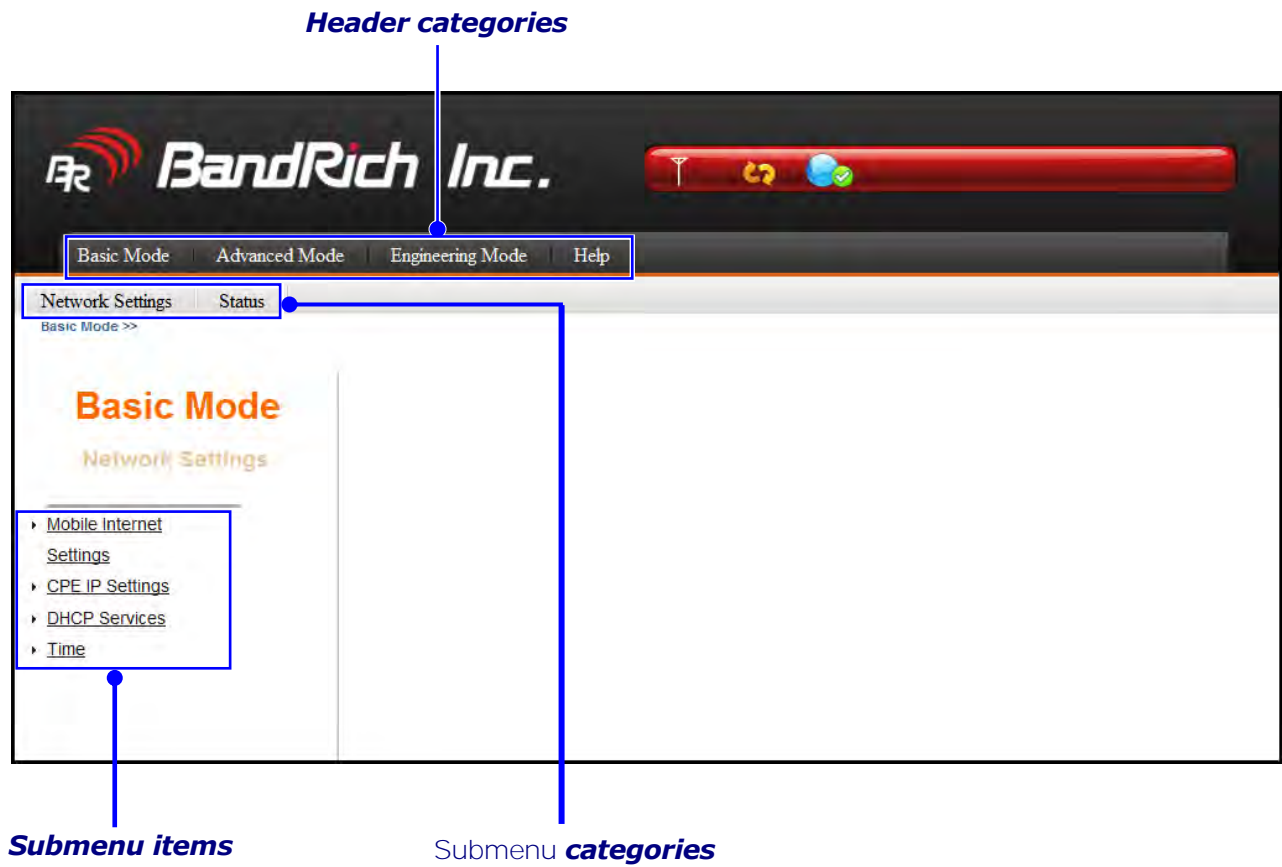

Basic Network Settings

With **Basic Mode**, you can configure the basic settings of CPE and view CPE status.

Configure Mobile Internet Settings

Set up your 4G mobile broadband connection.

1. Click **Basic Mode** tab and select **Network Settings**.
2. Click **Mobile Internet Settings**.

The screenshot shows the 'Mobile Internet Settings' configuration page. On the left, there is a sidebar with 'Basic Mode' and 'Network Settings' tabs. Under 'Network Settings', there are links for 'Mobile Internet Settings', 'CPE IP Settings', 'DHCP Services', and 'Time'. The main content area is titled 'Mobile Internet Settings' and contains three sections: 'APN', 'User Name', and 'Password'. Each section has a label, a text input field, and a radio button for 'Auto' (selected) and 'Manual'. Below these sections is an 'APPLY' button. The 'Network Preference' section has a label, a dropdown menu set to 'Auto', and another 'APPLY' button.

3. Configure the **APN** setting.
If there is a need for manual setting, enter the **APN** name, **User Name** and **Password**.
4. Click **APPLY** to save changes.

NOTE

- If you are not sure of the details, contact your 4G internet service provider for more information.

Configure CPE IP Settings

Modify the IP address configuration of your CPE.

1. Click **Basic Mode** tab and select **Network Settings**.
2. Click **CPE IP Settings**.

The screenshot shows a web interface for configuring CPE IP settings. The breadcrumb path is 'Basic Mode >> Network Settings >> CPE IP Settings'. The left sidebar shows 'Basic Mode' and 'Network Settings' with a list of options: Mobile Internet Settings, CPE IP Settings (highlighted), DHCP Services, and Time. The main content area is titled 'CPE IP Settings' and contains three sections: 'IP Address' with four input fields containing '192', '168', '168', and '168'; 'Subnet Mask' with one input field containing '255.255.255.0'; and 'Device Name' with one input field containing 'E500series.CPE'. At the bottom right, there are two buttons: 'APPLY' and 'CANCEL'.

3. Modify the necessary settings.
 - **IP Address:** Enter the IP address of the CPE. By default, the IP address is [192.168.168.168](#).
 - **Subnet Mask:** Display the mask used to divide the IP address.
 - **Device Name:** Type a device name to use to access the web-based utility instead of entering the IP address on the address bar. In the case of the above illustration, you may type <http://E500series.CPE> on the address bar to access the web-based utility.
4. Click **APPLY** to save changes.

Configure DHCP Services

Configure your CPE to use the Dynamic Host Configuration Protocol (DHCP). With DHCP service, your CPE will automatically assign an IP address to each computer on your network.

1. Click **Basic Mode** tab and select **Network Settings**.
2. Click **DHCP Services**.

The screenshot shows the DHCP Services configuration page. On the left, there is a sidebar with 'Basic Mode' and 'Network Settings' highlighted. Below this, a list of settings includes 'Mobile Internet', 'Settings', 'CPE IP Settings', 'DHCP Services' (which is selected), and 'Time'. The main content area is titled 'DHCP Services' and contains four sections: 'DHCP Server' with a dropdown menu set to 'Enable'; 'Start IP Address' with a text input field containing '192.168.168.1'; 'Maximum Number of Users' with a text input field containing '167'; and 'Client Lease Time' with a text input field containing '0' and a label 'minutes(0 means one day)'. At the bottom right, there are two buttons: 'APPLY' and 'CANCEL'.

3. Modify the necessary settings.
 - **DHCP Server:** Select to enable/disable the DHCP server.
 - **Start IP Address:** Assign the first IP from the range to be leased.
 - **Maximum Number of Users:** Enter the maximum number of IP addresses to be leased.
 - **Client Lease Time:** Set the amount of time that the IP address will still be reserved for the computer after it has been disconnected from the CPE.
4. Click **APPLY** to save changes.

Configure CPE Time

Adjust the current system date and time.

1. Click **Basic Mode** tab and select **Network Settings**.
2. Click **Time**.

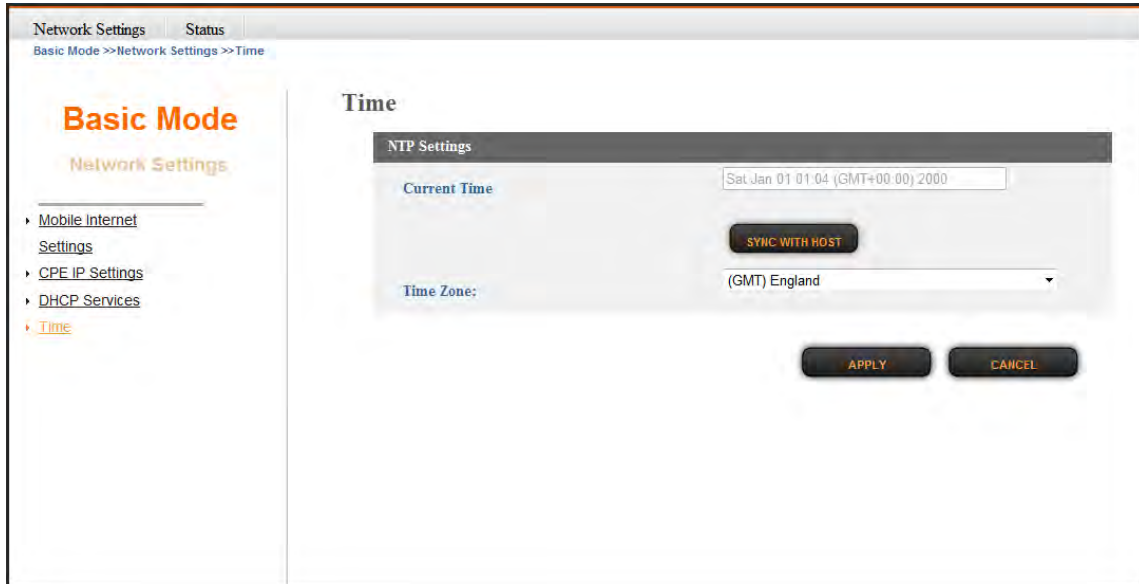

3. Modify the necessary settings.
 - **Current Time:** Display the current date and time. Click **SYNC WITH HOST** to synchronize with the computer date and time.
 - **Time Zone:** Select your local time zone from the list.
4. Click **APPLY** to save changes.

Status Information

View the CPE status information.

View Internet Connection Info

Display information on 4G status, 4G signal strength, network, and internet connection.

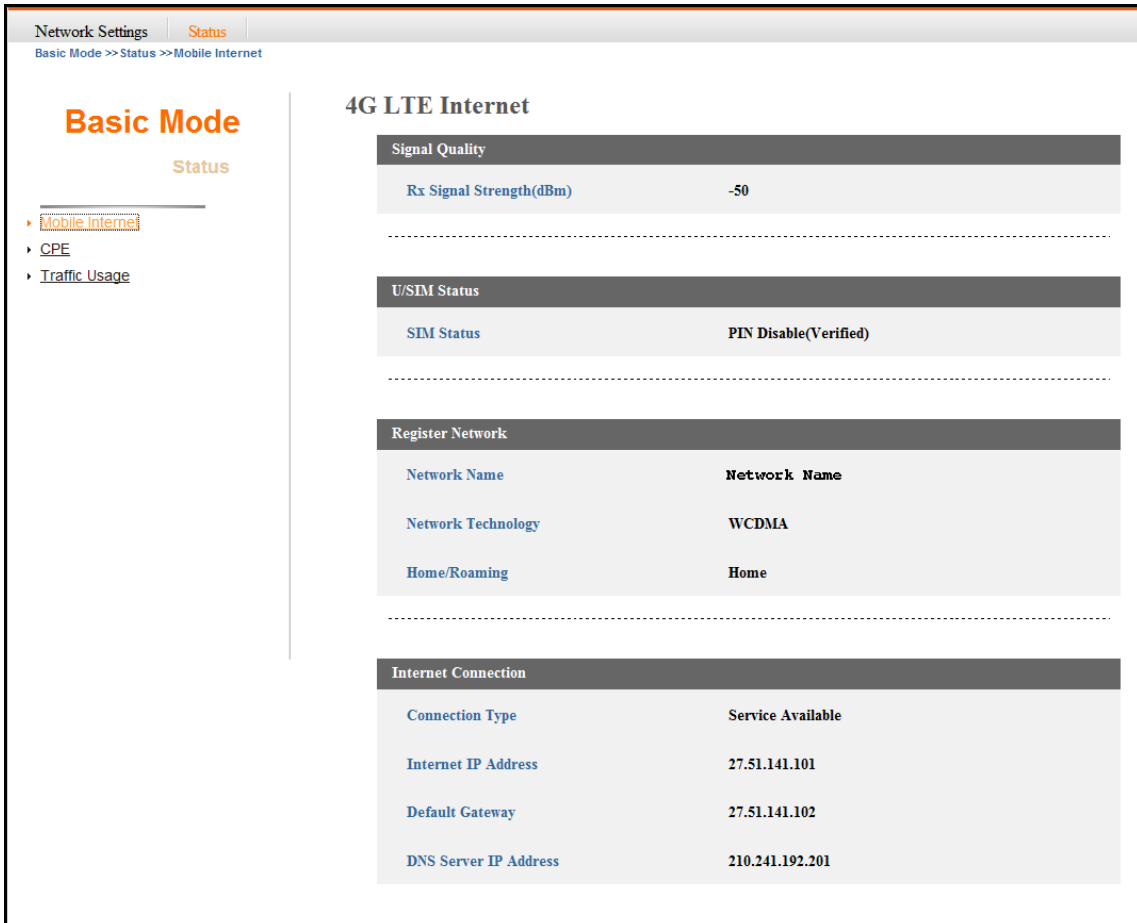

1. Click **Basic Mode** tab and select **Status**.
2. Click **Mobile Internet**. The following sections are shown:
 - **Signal Quality:** Displays the Rx signal strength.
 - **U/SIM Status:** Displays the SIM card status.
 - **Register Network:** Displays the network information and status. **Home/Roaming** displays whether the network is in Home or Roaming mode.
 - **Internet Connection:** Displays the Internet connection information, such as type, IP address, gateway, and DNS server.

View CPE Info

Display your CPE firmware version, local network settings, and DHCP client information.

1. Click **Basic Mode** tab and select **Status**.
2. Click **CPE**.

The screenshot shows the 'Network Settings' page with the 'Basic Mode' tab selected. The 'CPE' section is expanded, displaying the following information:

Firmware Information	
Firmware Version	RL_0_00003600_2_001_0180
Modem Version	QC_0_00016744_1_001_0100
Modem IMEI	357817040059178
Module Name	MS01
Current Time	Sat Jan 01 01:06 (GMT+00:00) 2000

Local Network	
Local MAC Address	00:26:FA:01:64:43
CPE IP Address	192.168.168.168
Subnet Mask	255.255.255.0
Operation Mode	Router Mode
DHCP Server	Enable
Start IP Address	192.168.168.1
IP Address Range	192.168.168.1 - 192.168.168.167

DHCP Clients			
Host Name	MAC Address	IP Address	Expires in
nh205	E0:CB:4E:95:86:F0	192.168.168.1	23:28:44

View Traffic Info

Display your CPE memory and network (WAN/LAN) data usage.

1. Click **Basic Mode** tab and select **Status**.
2. Click **Traffic Usage**.

The screenshot shows the 'Network Settings' page with the 'Basic Mode' tab selected. The 'Traffic Usage' section is expanded, displaying the following information:

Memory	
Memory total (KB)	61236
Memory left (KB)	39764

WAN/LAN	
WAN Rx (packets)	0
WAN Rx (bytes)	0
WAN Tx (packets)	426
WAN Tx (bytes)	248268
LAN Rx (packets)	7191
LAN Rx (bytes)	1007750
LAN Tx (packets)	8535
LAN Tx (bytes)	1324581

SIM/PIN Settings

You can protect the 4G SIM card installed on your CPE from unauthorized users by requiring the PIN code or entering a password.

Configure PIN

Set the PIN code to enable SIM card lock.

1. Click **Advanced Mode** tab and select **Mobile Internet Settings**.
2. Click **PIN Management**.

The screenshot shows the 'PIN Management' configuration page. The page is divided into three main sections: 'U/SIM PIN Verification', 'U/SIM PIN Management', and 'U/SIM's Change PIN'. Each section has a 'SIM Status' field, a 'PIN Code' input field, and 'APPLY' and 'CANCEL' buttons. The 'U/SIM PIN Management' section also includes a 'PIN Protection' dropdown menu set to 'Enable'. The left sidebar shows the navigation menu with 'Advanced Mode' selected and 'PIN Management' highlighted.

3. Modify the necessary settings.
 - **U/SIM PIN Verification:** Enter the PIN code.
 - **U/SIM PIN Management:** Enable/Disable PIN protection after typing a PIN code and clicking **APPLY**. The **PIN Protection** field shows the state you want to change to.
 - **U/SIM's Change PIN:** Change the PIN code.
4. Click **APPLY** to save changes.

Unlock SIM

Unlock SIM is applicable only for other types of SIM to which the services are originally locked. When the SIM card is accessed and an invalid SIM is displayed on the screen, you must enter the SIM unlock password to unlock the SIM card.

1. Click **Advanced Mode** tab and select **Mobile Internet Settings**.
2. Click **SIM Management**.

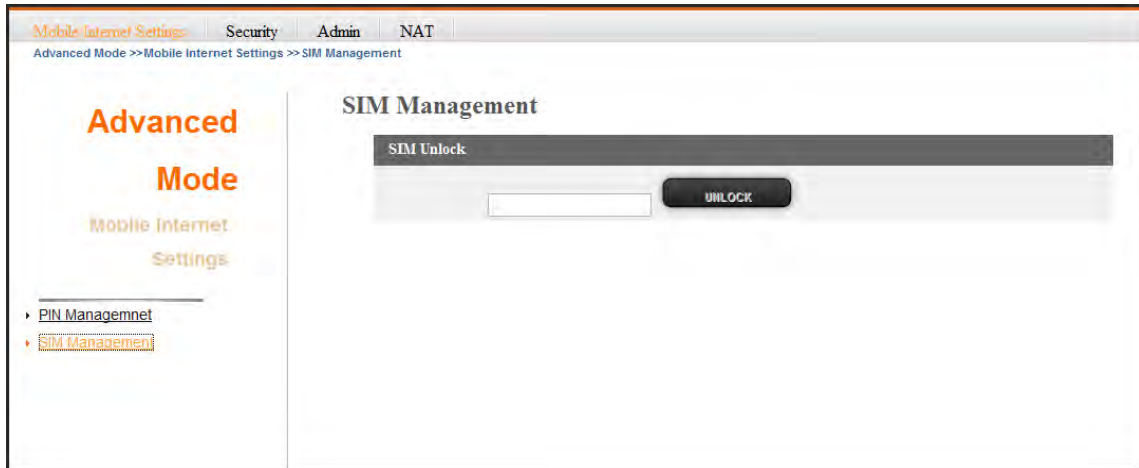

3. Enter the password.
4. Click **UNLOCK** to unlock the SIM card.

NOTE

- If you are not sure of the details, contact your 4G internet service provider for more information.

Security Settings

Configure firewall settings to suit your requirement.

1. Click **Advanced Mode** tab and select **Security**.
2. Click **Firewall**.

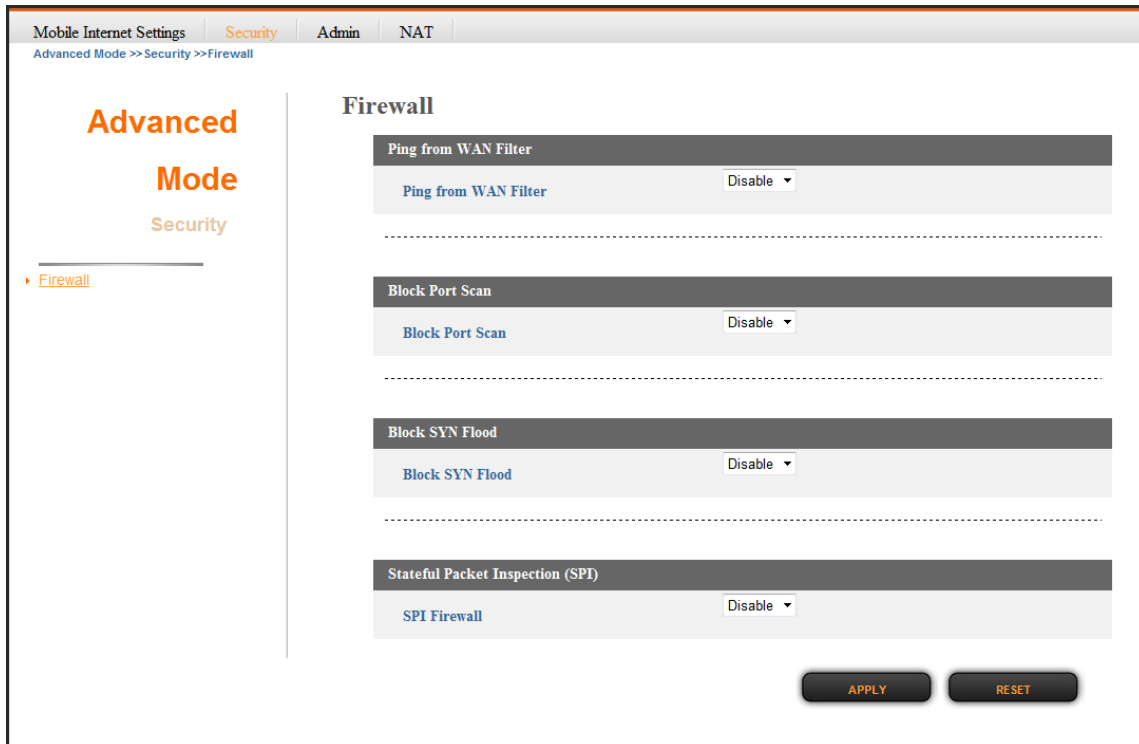

3. Modify the necessary settings.
 - **Ping from WAN Filter:** Select to enable/disable Ping permit from WAN. If this function is enabled, you can remotely ping the network device from the WAN side.
 - **Block port scan:** Port scanning means intruder across the network is scanning your computer for open ports possibly to see if there are any services running on your computer for hacking. Select whether to enable or disable the block port scan function.
 - **Block SYN Flood:** SYN Flood is a common Denial of Service (DoS) attack in which an attacker sends a succession or flood of SYN packets. Select whether to enable or disable the block SYN flood function.
 - **SPI Firewall:** SPI (Stateful Packet Inspection) Firewall filters more kinds of attacks by closely examining packet data structures. Select whether to enable or disable the SPI Firewall function.
4. Click **APPLY** to save changes.

Administrator Settings

Change the administrator password, configure remote access setting, set the timer duration for LED light, and select the operation mode of your CPE.

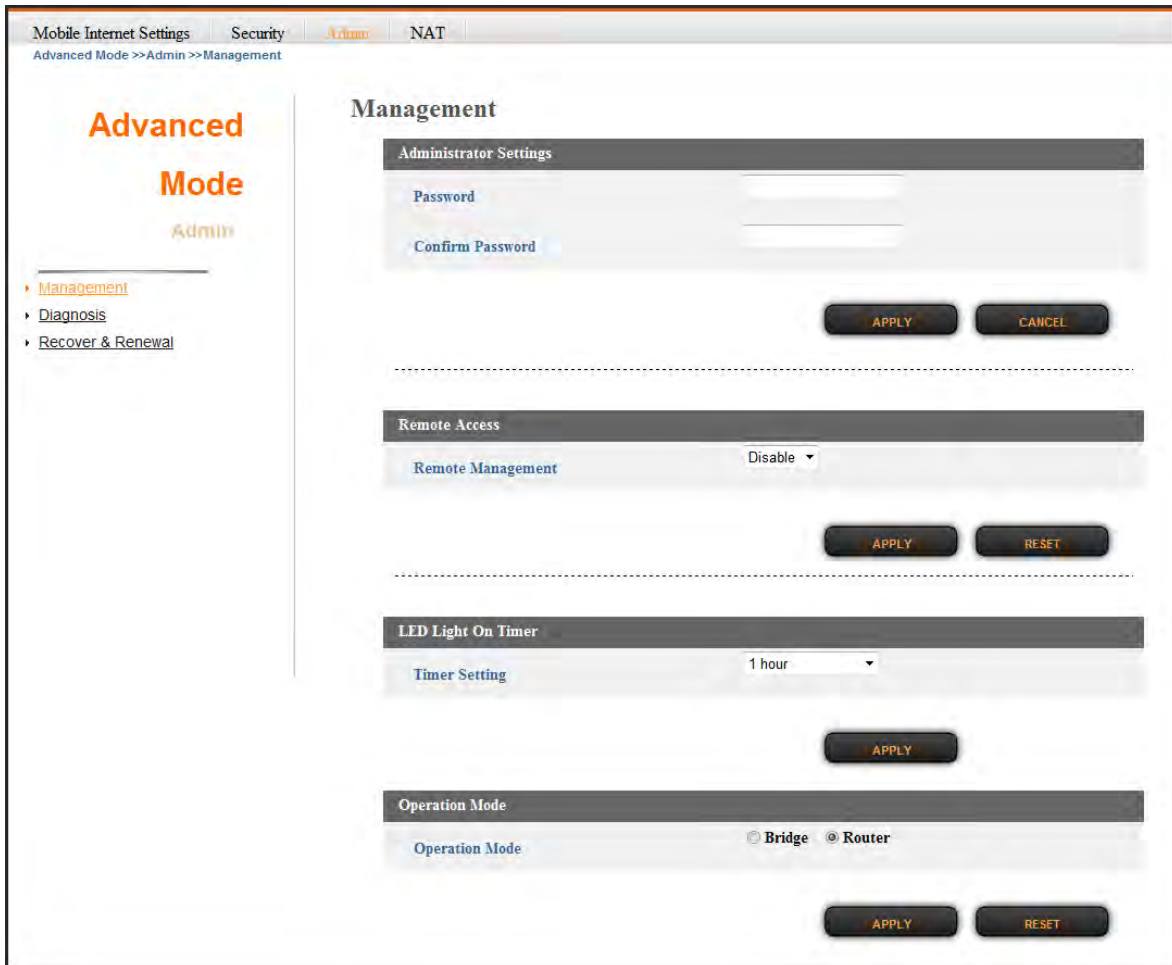

Change Web Management Password

Change the administrator password.

1. Click **Advanced Mode** tab and select **Admin**.
2. Click **Management**.
3. On **Administrator Settings**, do the following:
 - **Password**: Enter the new password.
 - **Confirm Password**: Enter again the new password for confirmation.
4. Click **APPLY** to save changes.

Enable Remote Access

Configure remote access settings.

1. Click **Advanced Mode** tab and select **Admin**.
2. Click **Management**.

LTE Outdoor CPE

3. On **Remote Access**, select **Enable** from the drop-down list to enable remote management function.
4. Click **APPLY** to save changes.

Manage LED Light

Set the duration for the LED light to stay on.

1. Click **Advanced Mode** tab and select **Admin**.
2. Click **Management**.
3. On **LED Light On Timer**, select the desired length of time from the drop-down list.
4. Click **APPLY** to save changes.

Select Operation Mode

Set the operation mode of the CPE.

1. Click **Advanced Mode** tab and select **Admin**.
2. Click **Management**.
3. On **Operation Mode**, select one of the following options:
 - **Bridge**: Select Bridge mode if you will have another router in your network to be set as the DHCP server. Clients in your network will directly receive IP address assigned by the server. After selecting Bridge mode, you may connect other routers or network devices. To access the CPE web-based utility in bridge mode, you must configure the IP address of the computer connected to the CPE with the IP address of the CPE.
 - **Router**: Select Router mode to use the CPE as a router.
4. Click **APPLY** to save changes.

Advanced Diagnosis

Set the system log, view the system log entries, and configure Ping and Traceroute tests settings.

The screenshot displays the 'Advanced Diagnosis' configuration page. On the left, a sidebar shows 'Advanced Mode' and 'Admin' tabs, with 'Diagnosis' selected. The main content area is titled 'Diagnosis' and contains three sections:

- Enable Syslog:** A section with a checkbox and a text input field for 'Syslog IP'.
- System Log:** A section showing a list of log entries. The entries are:

```
Jan 1 01:42:17 E500 syslog.info syslogd started: BusyBox v1.12.1
Jan 1 01:42:17 E500 user.notice kernel: klogd started: BusyBox v1.12.1 (2012-07
Jan 1 01:42:19 E500 user.debug syslog: [Recv3GPacket] ThreeG_CMD_GET_CONFIG_ALL
Jan 1 01:42:19 E500 user.debug syslog: [Send3GInfoAll] Send3GInfoAll 20
```

 Below the log entries are 'REFRESH' and 'CLEAR' buttons.
- Ping test:** A section with input fields for 'IP or Address', 'Packet size' (set to 'Bytes(32-2048)'), and 'Number of Pings' (set to '5'). Below these fields are 'APPLY' and 'RESET' buttons.
- Traceroute test:** A section with an 'IP or Address' input field and 'APPLY' and 'RESET' buttons below it.

Enable SysLog

Configure the system log settings.

1. Click **Advanced Mode** tab and select **Admin**.
2. Click **Diagnosis**.

3. On **Enable Syslog**, do the following:
 - **Enable Syslog**: Click **Enable** to enable the system log.
 - **Syslog IP**: Specify the IP address of the server that will receive the system log.
4. Click **APPLY** to save changes.

View System Log

View the current system log entries.

1. Click **Advanced Mode** tab and select **Admin**.
2. Click **Diagnosis**.
3. On **System Log**, it displays the current system log entries.
 - Click **REFRESH** to refresh the log shown on the screen.
 - Click **CLEAR** to clear the current system log data.

Use Ping Test

Allow the CPE to ping the network devices to verify their connection.

1. Click **Advanced Mode** tab and select **Admin**.
2. Click **Diagnosis**.
3. On **Ping test**, do the following:
 - **IP or Address**: Enter the IP address of the network device that you want to ping.
 - **Packet size**: Enter the packet size.
 - **Number of Pings**: Enter the number of pings.
4. Click **APPLY** to ping other network device.

Use Traceroute Test

Allow the CPE to trace the route that test packets take from one web destination to another. This function is commonly used to troubleshoot network problems and identify routing problems or firewalls that may be blocking access to a web site.

1. Click **Advanced Mode** tab and select **Admin**.
2. Click **Diagnosis**.
3. On **Traceroute test**, enter the IP or the domain name on **IP or Address**.
4. Click **APPLY** to monitor a network trace.

System Maintenance

Configure the settings to back up and restore the CPE configurations, upgrade the APN and CPE firmware, and reset the CPE to factory default settings.

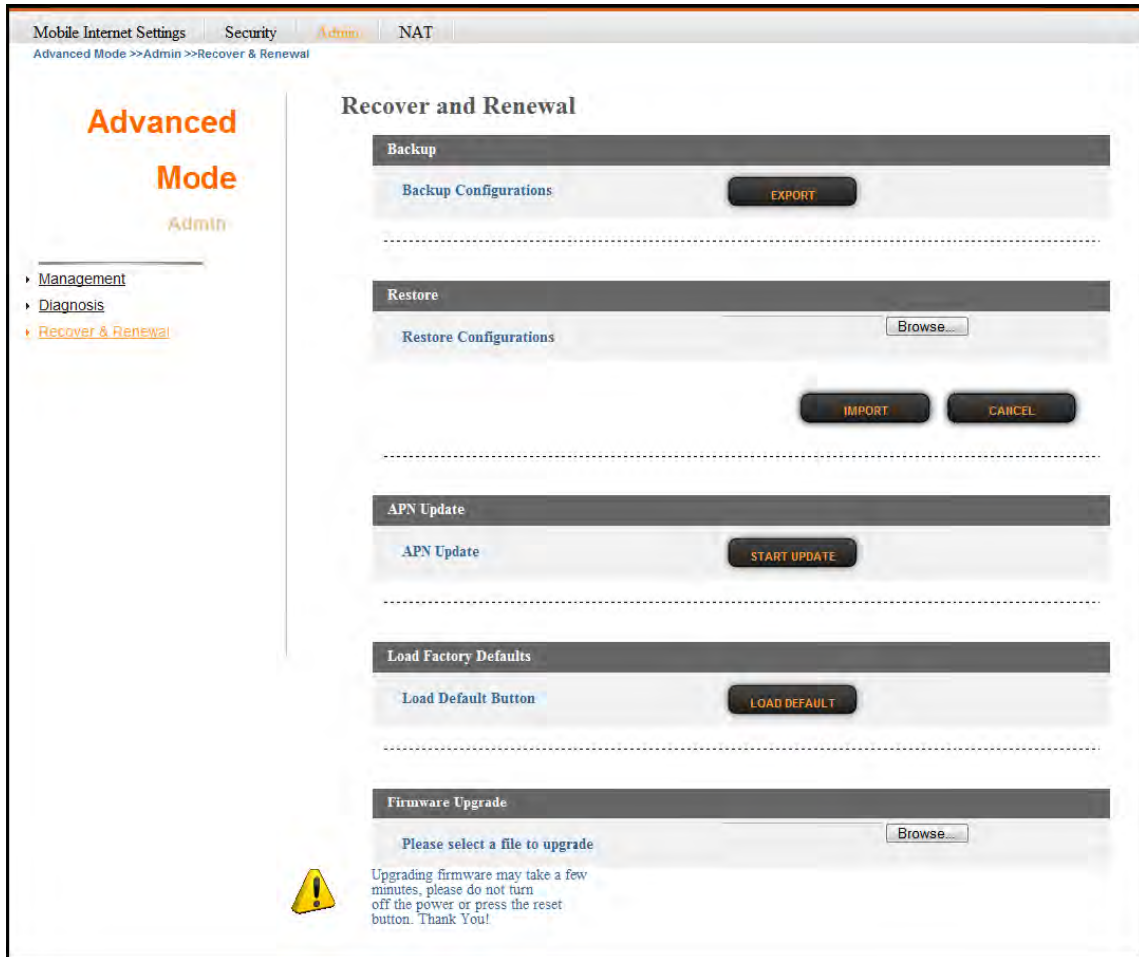

Backup Configuration

Back up the CPE configuration to your computer.

1. Click **Advanced Mode** tab and select **Admin**.
2. Click **Recover & Renewal**.
3. On **Backup**, click **EXPORT** to export the current configurations to your computer.

Restore Configuration

Restore the previously saved backup of the CPE configuration.

1. Click **Advanced Mode** tab and select **Admin**.
2. Click **Recover & Renewal**.

LTE Outdoor CPE

3. On **Restore**, click the **Browse** button and select the previously saved configuration file in your computer.
4. Click **IMPORT** to update the CPE configuration.

Update APN

Update the APN database.

1. Click **Advanced Mode** tab and select **Admin**.
2. Click **Recover & Renewal**.
3. On **APN Update**, click **START UPGRADE** to update the APN.

Restore Factory Defaults

Reset your CPE to the factory default settings.

1. Click **Advanced Mode** tab and select **Admin**.
2. Click **Recover & Renewal**.
3. On **Factory Defaults**, click **LOAD DEFAULT** to reset all configuration parameters to the factory defaults settings.

Upgrade CPE Firmware

Update the firmware of your CPE.

1. Click **Advanced Mode** tab and select **Admin**.
2. Click **Recover & Renewal**.
3. On **Firmware Upgrade**, click the **Browse** button and select the latest firmware in your computer.
4. Click **START UPGRADE** to upgrade the CPE firmware.

NAT Settings

Configure the network address translation (NAT) settings of the CPE.

Configure Single Port Forwarding

Single Port Forward allows users on the Internet to access this server by using the WAN port address and the matched external port number. When users send these types of request to your WAN port IP address via the Internet, the CPE will forward those requests to the appropriate servers on your LAN. Configured single port forward settings are listed on the table at the bottom of the screen.

1. Click **Advanced Mode** tab and select **NAT**.
2. Click **Single Port Forward**.

Mobile Internet Settings | Security | Admin | **NAT**

Advanced Mode >> NAT >> Single Port Forward

Advanced Mode

NAT

- Single Port Forward
- Port Range Forward
- Port Range Trigger
- UPnP
- DMZ

Single Port Forward

Application

LAN IP

IP Address

Port

External

Internal

Protocol: TCP&UDP

APPLY RESET

Single Port Forward

Enabled/Disabled: Disable

APPLY RESET

Current Port Forward in System (The maximum is 10)

No.	IP Address	External Port	Internal Port	Protocol	Application

DELETE SELECTED RESET

3. To configure the port forwarding, do the following:

- **Application:** Enter a rule name.
- **LAN IP:** Enter the local network IP address of the system hosting the server.

- **Port**
 - **External:** Enter the external port to be redirected to **Internal port**.
 - **Internal:** Enter the port used by the device to receive data.
 - **Protocol:** Select the protocol from the drop-down list.
 - **Single Port Forward**
 - **Firewall enable or disable:** Select **Enable** from the drop-down list to enable firewall.
4. Click **APPLY** to save the configuration rules.

Configure Port Range Forward

Port Range Forward allows users on the Internet to access this server by using the WAN port IP address and the pre-defined range of ports. When users send these types of request to your WAN port IP address via the Internet, the CPE will forward those requests to the appropriate servers on your LAN. Configured port range forward settings are listed on the table at the bottom of the screen.

1. Click **Advanced Mode** tab and select **NAT**.
2. Click **Port Range Forward**.

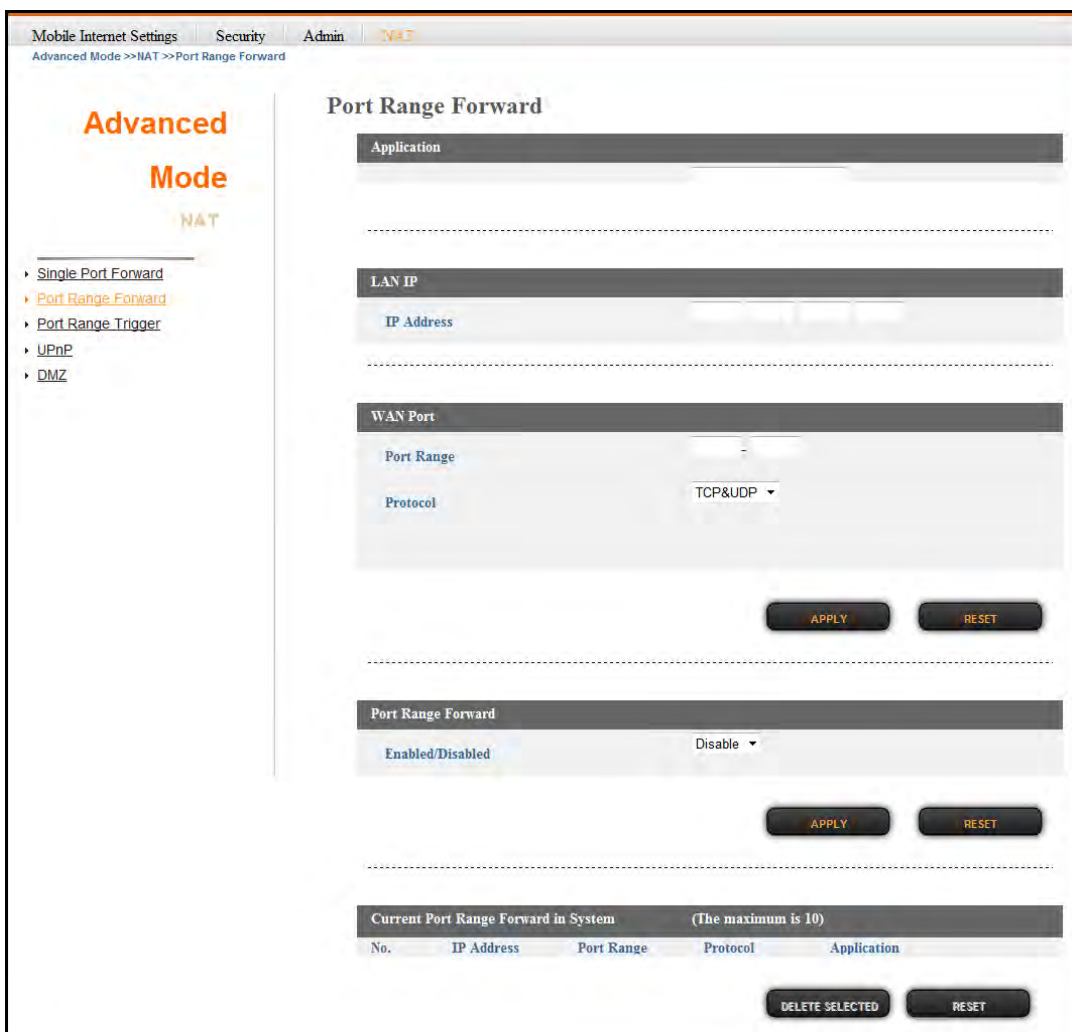

3. To configure the port forwarding, do the following:
 - **Application:** Enter a rule name.
 - **LAN IP:** Enter the local network IP address of the system hosting the server.
 - **WAN Port**
 - **Port Range:** Enter the start-port and end-port used by the public port from the WAN side.
 - **Protocol:** Select the protocol from the drop-down list.
 - **Port Range Forward**
 - **Enabled/Disabled:** Select **Enable** from the drop-down list to enable firewall.
4. Click **APPLY** to save the configuration rules.

Configure Port Range Trigger

Port trigger allows the device to monitor firstly if traffic on certain ports of a computer is being triggered or being sent out; if so, the incoming traffic from the Internet on certain ports will be allowed to pass into the same computer.

1. Click **Advanced Mode** tab and select **NAT**.
2. Click **Port Range Trigger**.

The screenshot shows the NAT configuration interface in Advanced Mode. The breadcrumb trail is: Mobile Internet Settings > Security > Admin > NAT > Advanced Mode >> NAT >> Port Range Trigger. The left sidebar shows the 'Advanced Mode' menu with 'Port Range Trigger' selected. The main content area is titled 'Port Range Trigger' and contains the following sections:

- Application Configuration:** Fields for 'Application' (text input), 'Protocol' (dropdown menu set to 'TCP&UDP'), 'Triggered Range' (text input), and 'Forwarded Range' (text input). Below these are 'APPLY' and 'RESET' buttons.
- Port Range Trigger Status:** A dropdown menu for 'Enabled/Disabled' set to 'Disable'. Below it are 'APPLY' and 'RESET' buttons.
- Current Port Range Trigger in System:** A table showing the current configuration. The note '(The maximum is 10)' is displayed. The table has columns: No., Protocol, Triggered Range, Forwarded Range, and Application. Below the table are 'DELETE SELECTED' and 'RESET' buttons.

No.	Protocol	Triggered Range	Forwarded Range	Application
(The maximum is 10)				

3. To configure the settings, do the following:

- **Application**

- **Application:** Enter a rule name.
- **Protocol:** Select the trigger port protocol from the drop-down list.
- **Triggered Range:** Enter the start-port and end-port that will trigger the device to open ports for incoming data.
- **Forwarded Range:** Enter the start-port and end-port used by the public port from the WAN side.

- **Port Range Trigger**

- **Enabled/Disabled:** Select **Enable** from the drop-down list to enable firewall.

4. Click **APPLY** to save the configuration rules.

Enable UPnP

Universal Plug and Play (UPnP) allows automatic discovery and control of services available on the network from other devices without user intervention.

1. Click **Advanced Mode** tab and select **NAT**.
2. Click **UPnP**.

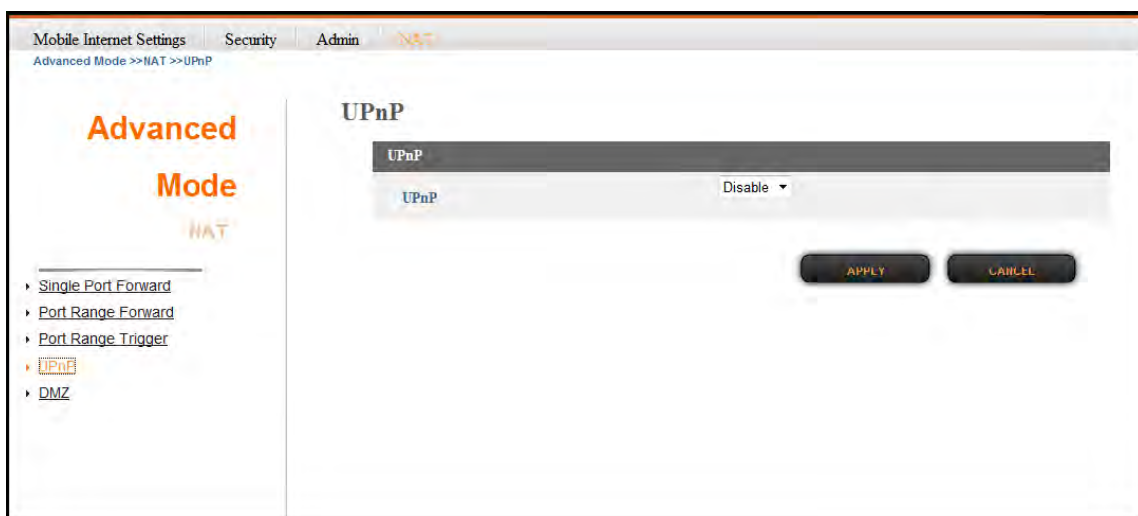

3. On **UPnP**, select **Enable** from the drop-down list to enable the UPnP feature.
4. Click **APPLY** to save changes.

Configure DMZ

A DMZ (Demilitarized Zone) sets a single computer, called a DMZ host, on your network to receive unrestricted incoming traffic from the Internet.

1. Click **Advanced Mode** tab and select **NAT**.
2. Click **DMZ**.

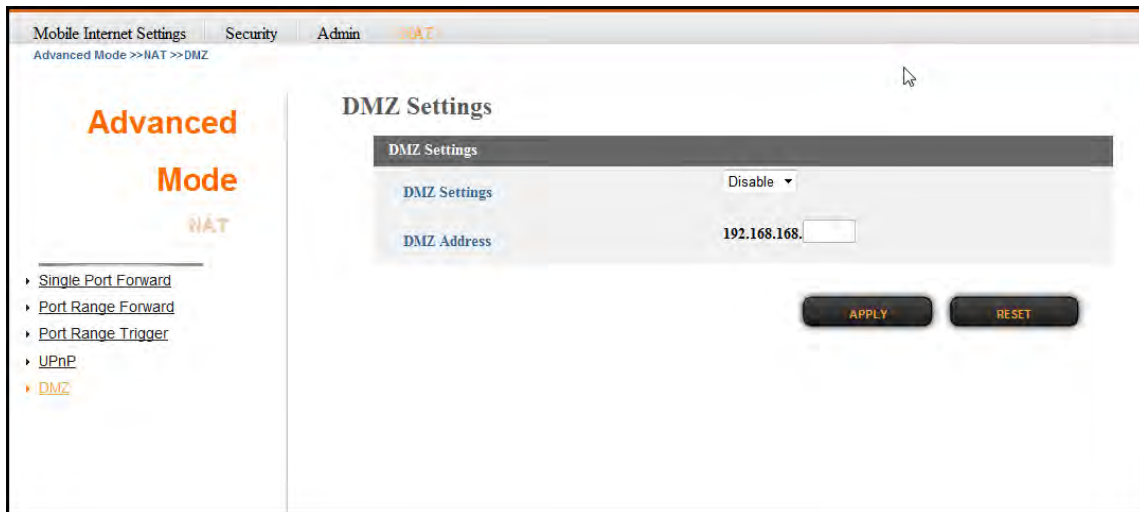

3. On **DMZ Settings**, do the following:
 - **DMZ Settings**: Select **Enable** from the drop-down list to enable the DMZ function.
 - **DMZ Address**: Enter the IP address of the DMZ host.
4. Click **APPLY** to save changes.

Engineering Mode

Reset all cellular information.

1. Click **Engineering Mode** tab.
2. Click **Cell Information**.

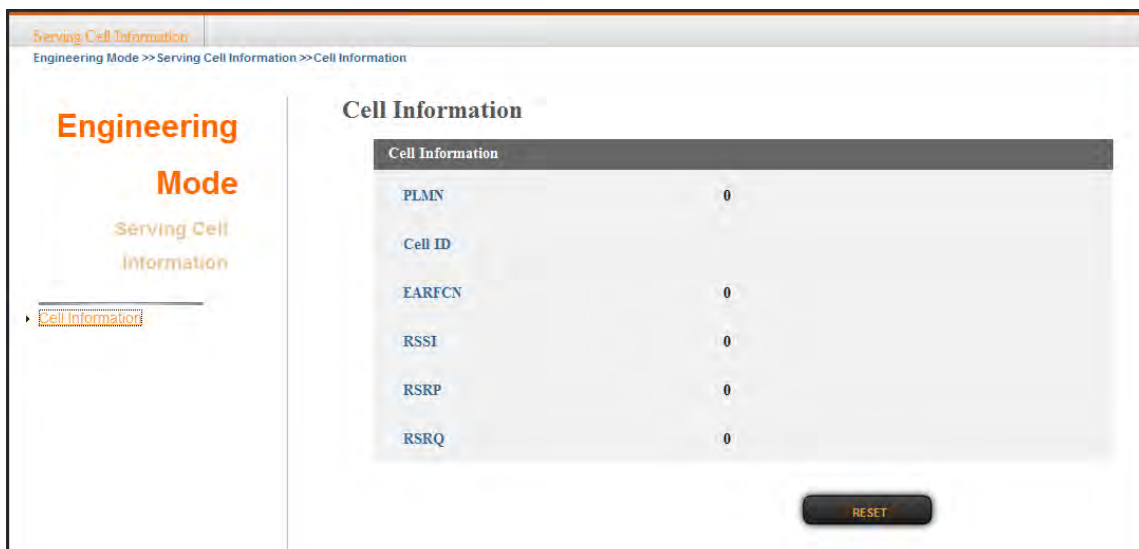

3. Click **RESET** to reset the cellular information.

Appendix

FAQ

This chapter contains a list of frequently asked questions when you set up your CPE configuration.

Q: What and how to find my computer IP address?

A: IP address is the identifier for a computer or device on a TCP/IP network. Networks using the TCP/IP protocol route messages based on the IP address of the destination. The format of an IP address is a 32-bit numeric address written as four numbers separated by periods. Each number can be zero to 255.

For example, 192.168.168.254 could be an IP address.

To find your computer IP address,

- ➔ In Windows, click **Start > Run** to launch the **Command** program.
- ➔ Type "ipconfig", then press the **Enter** button.
- ➔ Your computer IP address is listed on the *IP Address*.

Q: What is Long Term Evolution (LTE)?

A: LTE is a 4th generation (4G) mobile broadband standard and is the successor to the 3G technologies CDMA/GSM/UMTS. The service is typically much faster on both uplink/download speeds.

Q: What is a firewall?

A: A firewall is a set of related programs that protects the resources of a private network from users from other networks.

Q: What is Network Address Translation (NAT)?

A: Network Address Translation (NAT) is the process where a network device, usually a firewall, assigns a public address to a computer (or group of computers) inside a private network.

Q: What is Universal Plug and Play (UPnP)?

A: UPnP is an open networking architecture that consists of services, devices, and control points. The ultimate goal is to allow data communication among all UPnP devices regardless of media, operating system, programming language, and wired/wireless connection.

Troubleshooting

This chapter contains a list of common problems that you might experience when using your CPE, and techniques to try and overcome the problem. If you need additional help, contact your retailer.

Problems	Solutions
I cannot acquire network connection.	Make sure that a 4G SIM card is properly inserted to the CPE.
	<ul style="list-style-type: none"> • Check if the Ethernet cable is properly connected. • If you are using a PoE adapter, make sure that the Ethernet cables are properly connected and the power adapter is plugged into an appropriate power source.
	3. Ensure you obtained the correct Access Point Name (APN) supplied by the SIM card carrier.
The Power LED did not light up when I plugged the adapter.	Make sure that the power adapter is connected to the CPE and plugged in to an appropriate power source. Use only the supplied power adapter.
	Check that the power source is receiving sufficient power.
	If the error persists, you may have a hardware problem. In this case, you should contact technical support.
I cannot access the web management page.	Make sure you are using the correct IP address of the CPE.
	Your computer and the CPE IP addresses must be on the same subnet for local network (LAN) access. You can check the subnet in use by the CPE on the Basic Network settings.
I forgot my login username and/or password.	Press the Reset button for five seconds to reset the settings to the factory default settings. Access the web management page. You can now login with the factory default username and password "admin" .

Specifications

Features		Specifications								
Cellular Connectivity and Data Speed										
Model	E503	E503T	E504	E507	E512	E513	E520	E538	E540	E525
LTE band	Band 3	Band 3	Band 4	Band 7	Band 12 Band 17	Band 13	Band 20	Band 38	Band 40	Band 25 Band 2
EVDO Band	-		-	-	-	-	-	-	-	BC1 (1900)
DC-HSPA+		850								
DL Peak Data Rate	100Mbps									
UL Peak Data Rate	50Mbps									
LTE Bandwidth	Up to 20 MHz supported (real allocation depends on LTE channel planning)									
Antenna	Antenna Type		Embedded high gain directional antenna							
	Antenna Gain		10~13dB gain (depends on model type)							
	RX Diversity Antenna		Built-in design							
	MIMO		Downlink 2x2 SU-MIMO							
Water Resistant	IP Code		IP66							
Interface	Ethernet Port		RJ45 x 1 (with power riding on Ethernet cable)							
	SIM Slot		Yes							
	USB 2.0		Micro USB 2.0 for debug purpose							
	Reset Button		Reset to factory default setting							
	LED Indicator		Signal strength indicators: LED x 5 Power indicator: LED x 1 LED light up timer: 5 min / 15 min / 30 min (default) / 60 min							
Router Features	Security		Multiple VPN pass-through (IPSec, PPTP, L2TP), Firewall Protection (Block Port Scan/Block SYN Flood/Filter Ping from WAN), SPI Firewall							
	NAT-NAPT		Single Port Forward, Port Range Forward, Port Range Trigger, DMZ, UPnP							
	DHCP		DHCP Server/Client							
	Other features		IPv4, TCP, UDP, ICMPv4, ARP, HTTP/HTTPs							

Features		Specifications
CPE Management	CPE Operation Mode	Two modes of operation: Bridge or Router mode
	System Protection	Two types of user account: User and Operator. Every user account has his own password protected mechanism
	Browser-based Administration GUI	Browser supported: IE, Firefox, Safari, Chrome
	Browser-based Administration GUI Multi-Language Support	English
Remote Management	Web Browser Interface	HTTP
	Command Line Interface	Telnet, SSH
Power Input	Passive Power over Ethernet Support (PPoE)	Yes, both 12V and 48V passive PoE input power supported
	CPE power consumption	Max 6.6 Watts when heater is off Max 23 Watts when heater is on
Environment	Operation Temperature (Excluding Power adaptor)	-40°C to 65°C (-40°F to 149°F)
	Power Adapter Operation Temperature	0°C to 40°C (32°F to 104°F)
	Storage Temperature	-40°C to 70°C (-40°F to 158°F)
	Operating Humidity	10% to 80% (Non-Condensing)
	Storage Humidity	5% to 90% (Non-Condensing)
Dimensions	423.5 (L) x 309.5 (W) x 104 (H) mm	
Weight	2kg	
Certification	FCC, RoHS	

Specifications are subject to change without prior notice.

Safety Information

Read and understand all safety information. Failure to follow all instructions listed below may result in electric shock, fire and/or serious personal injury.

Power Cord Protection

- ❖ Do not connect the power supply cord on elevated surfaces.
- ❖ Avoid any obstructions in its path and no heavy items should be placed on the cord.
- ❖ Protect the power cord from being walked on or pinched.

Object Entry

- ❖ Never insert objects of any kind through the openings of the CPE, as they may touch dangerous voltage points that could result in a fire or electric shock.

Operating Environment

- ❖ Do not mount the CPE near any heat sources such as radiators, heat registers, stoves, or other apparatus (including amplifiers) that produce heat.

Accessories

- ❖ Use only accessories specified by the manufacturer.

Cleaning

- ❖ Unplug the CPE from the power outlet before cleaning. Use only a dry cloth to clean the device.

Servicing

- ❖ Never attempt to disassemble the CPE yourself.
- ❖ In the unlikely event that smoke, abnormal noise, or strange odor is present, immediately turn off the CPE.
- ❖ Refer all servicing to qualified service personnel.

Federal Communication Commission Interference Statement

This device complies with Part 15 of the FCC Rules. Operation is subject to the following two conditions: (1) This device may not cause harmful interference, and (2) this device must accept any interference received, including interference that may cause undesired operation.

This equipment has been tested and found to comply with the limits for a Class B digital device, pursuant to Part 15 of the FCC Rules. These limits are designed to provide reasonable protection against harmful interference in a residential installation. This equipment generates, uses and can radiate radio frequency energy and, if not installed and used in accordance with the instructions, may cause harmful interference to radio communications. However, there is no guarantee that interference will not occur in a particular installation. If this equipment does cause harmful interference to radio or television reception, which can be determined by turning the equipment off and on, the user is encouraged to try to correct the interference by one of the following measures:

- ❖ Reorient or relocate the receiving antenna.
- ❖ Increase the separation between the equipment and receiver.
- ❖ Connect the equipment into an outlet on a circuit different from that to which the receiver is connected.
- ❖ Consult the dealer or an experienced radio/TV technician for help.

FCC Caution: Any changes or modifications not expressly approved by the party responsible for compliance could void the user's authority to operate this equipment.

This transmitter must not be co-located or operating in conjunction with any other antenna or transmitter.

Radiation Exposure Statement:

This equipment complies with FCC radiation exposure limits set forth for an uncontrolled environment. This equipment should be installed and operated with minimum distance 20cm between the radiator & your body.