

Introducing the Banner DX80 Wireless System

The DX80 wireless system provides continuous monitoring without the burden of wiring or conduit installation, and can operate independently or in conjunction with a PLC and/or PC software. Configurations of the DX80 wireless system are shown below.



All Digital

Model Number
DX80K*M6DP1
DX80K*M6DP2
DX80K*M6DP4
DX80K*M6DP7



Digital and Analog

Model Number
DX80K*M6MP1
DX80K*M6MP2
DX80K*M6MP7



Repeater

Model Number
DX80K*R6DP1
DX80K*R6DP2
DX80K*R6DP4
DX80K*R6MP1
DX80K*R6MP2



Host-Connected

Model Number
DX80K*S6DP*
DX80K*S6MP*
DX80K*S3PE*
DX80K*S3GE*

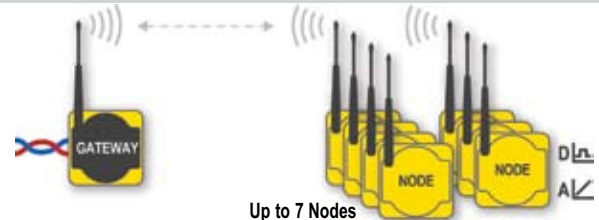

FLEX Power

Model Number
DX80K*M3PE1
DX80K*M3GE1
DX80K*S3PE*
DX80K*S3GE*
DX80K*R3PE1
DX80K*R3GE1

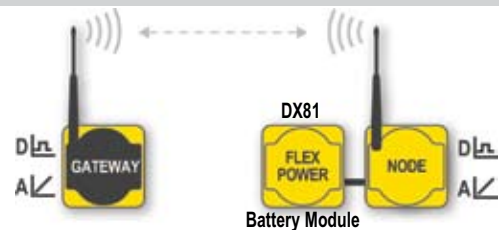
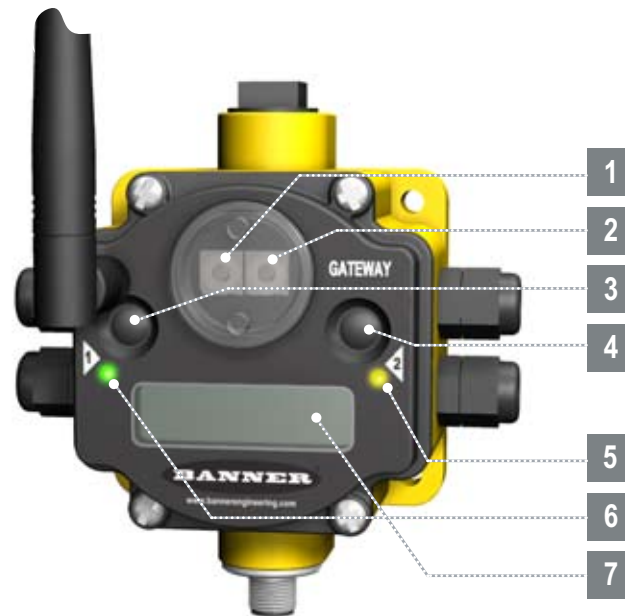

Table of Contents

Overview	1
Setting Up	2
Quick Start	
STEP 1: Set NID & Device Address	4
STEP 2: Apply Power (Gateway)	5
STEP 3: Apply power (Node)	5
STEP 4: Verify Communications	6
STEP 5: Site Survey	7
Host Network	8
Product Dimensions	11
Menu System	12
Troubleshooting	16

DX80 Gateway and Node Front-Panel Interface



Rotary Switches: Used to set Network ID & Device Address

1 Rotary Switch 1 (left)

Sets the Network ID (NID) to a value from 0 to 15

2 Rotary Switch 2 (right)

On Gateway: Sets Device Address and displays its settings On Node: Sets the Node's Device Address (1-7)

Push Buttons: Used to navigate the Gateway and Node menus and program device configurations

3 Push Button 1

Single-click to advance across all DX80 menus.



4 Push Button 2

Single-click to move down interactive menus.
Double-click to move back to top-level menu.

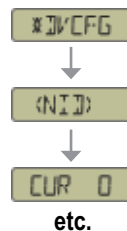

5 6 LED 1 and 2

Provide real-time feedback to the user regarding RF link status, serial communications activity, and Error state.

7 LCD Display

Six-character display provides run mode user information and shows enabled I/O point status. This display allows the user to conduct a Site Survey (RSSI), assign Network ID, and modify other DX80 configuration parameters without the use of a PC or other external software interfaces.

DX80 Gateway and Node Wiring Chamber

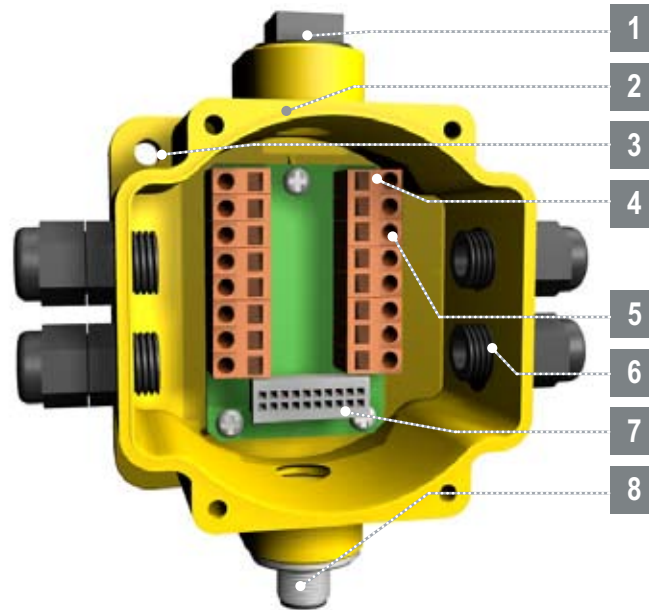

- 1 Port, NPT Gland or Plug**
1/2 NPT threaded port can accept provided plug.
- 2 Housing**
Rugged, industrial DX80 housing is rated IEC IP67
- 3 Mounting Hole, #10/M5 Clearance**
Mounting Holes accept metric M5 or UNC/UNF #10 hardware -- DIN rail mount adapter bracket available
- 4 Wiring Terminal Strip**
- 5 Wiring Terminal**
Wiring terminal is of spring-clip type. Each of the 16 wiring terminals will accept wire sizes: AWG 12-28 or 2.5 mm²
- 6 Port, PG-7 Gland or Blank**
PG-7 threaded port can accept provided cable glands or blanks.
- 7 Ribbon Connector**
Ribbon cable connects wiring base to LCD/radio.
- 8 5-Pin M12 Euro-style quick-disconnect fitting**

Quick Start: **STEP 1** > Set Network ID & Device/Node Address

The Banner DX80 wireless system is a network of devices consisting of a Gateway and Node(s).

The network is defined by the Network ID (NID) assigned to the Gateway and its Node(s). Additionally, each device within this common network (NID) must have a unique Device Address assigned.

Use the Rotary Switches (shown right) to define both the NID and Device Address for each device. Follow the steps below to set up your DX80 network.

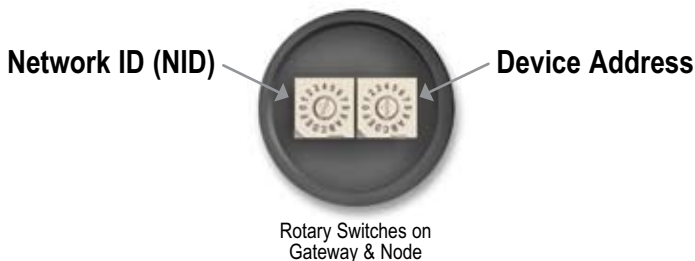

	User Action	Display/Status	Notes
SET NETWORK ID	Remove rotary switch access covers.		Turn counterclockwise to remove and clockwise to tighten
	On the Gateway , set the Left Rotary Switch to 1.		The factory default NID setting on all devices is 1
	On all Nodes (within the same network), set the Left Rotary Switch to 1.		Assign the same NID to all devices within a single network (0-15). A-F is 10-15 respectively.
SET DEVICE ADDRESS	On the Gateway , set the Right Rotary Switch to 0.		A Device Address of 0 on the Gateway will display settings for the Gateway itself. To view settings for another device on the network, adjust the Right Rotary Switch on the Gateway to the respective Device Address.
	On the first Node (Device Address = 1), set the Right Rotary Switch to 1.		
	On the second Node (Device Address = 2), set the Right Rotary Switch to 2.		
	Continue setting the Device Address for each additional Node using a unique number (.3,4,5).		
	Install rotary switch access covers.		A successful RF link is identified by: <ul style="list-style-type: none"> • The Gateway's LED 1 is Green • The Node(s) LED 1 is Flashing Green

Multiple Networks:

When more than one network is operating in the same space, assign a unique Network ID (NID) to each network (shown right).

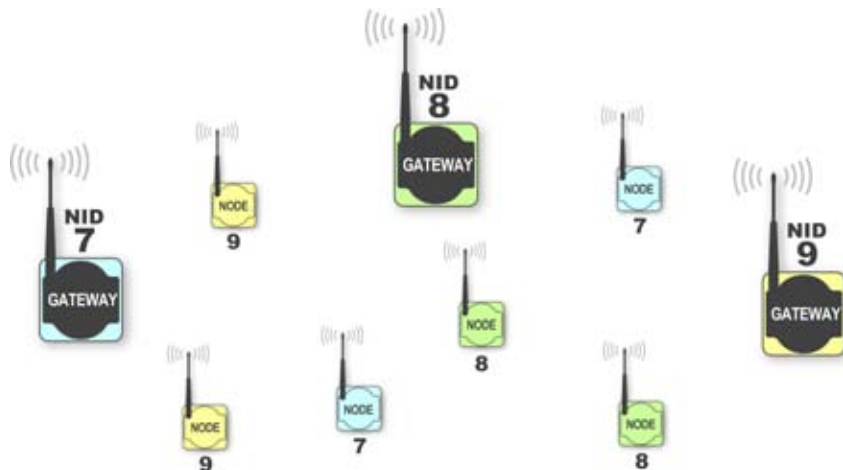

Quick Start: **STEP 2** > Apply Power, Gateway

To apply power to the **Gateway**, connect 10-30V dc cable as shown.

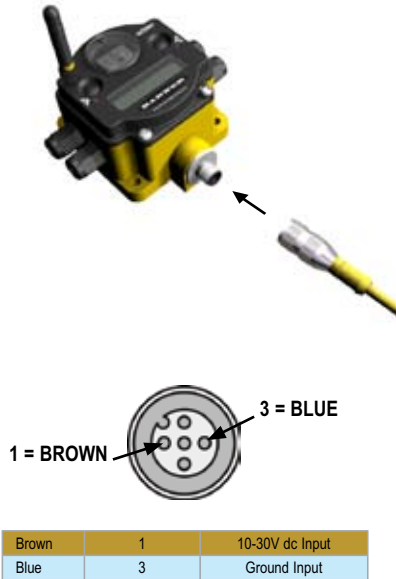

Apply power...		This reading occurs only at initial application of power to the Gateway.
The LCD display shows the current I/O status of the Gateway.		The Gateway starts in RUN mode.
		Displays current Network ID (NID)
		Device is ...
		... Gateway (Device Address = 0)
		Indicates the current status of the I/O. The display will cycle through each I/O point of the device, then return to *RUN.
		repeat

Quick Start: **STEP 3** > Apply Power, Node

To apply power to the **Node**, connect 10-30V dc cable or DX81 Battery Module as shown.

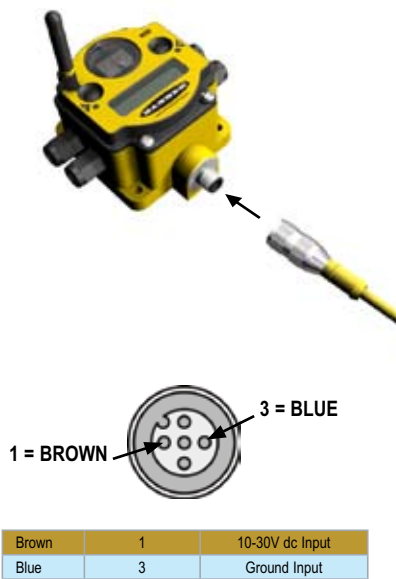

Apply power...		This reading occurs only at initial application of power to the Node.
The LCD display shows the current I/O status of the Node.		The Node starts in RUN mode.
		Displays current Network ID (NID)
		Device is ...
		... Node 1 (Node Address = 1)
		Indicates the current status of the I/O. The display will cycle through each I/O point of the device, then return to *RUN.
		repeat

Quick Start: STEP 4 > Verify Communications, Gateway

Verify LED 1 is ON Green.

Gateway

LED Status	LED 1	LED 2
● Green ON	Power ON	—
● Green FLASHING	—	—
● Red ON	System Error	RS485 Error
● Red FLASHING	—	RS485 Fault
● Yellow FLASHING	—	RS485 Active



> Verify Communications, Node

Verify LED 1 is flashing Green. LED 2 is off. Until communication is established with the Gateway, the Node's LED 2 flashes Red. When communication is established, the Node's LED 1 flashes Green.

Node











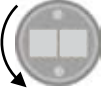











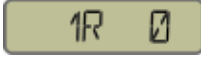
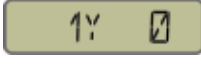
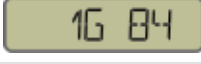

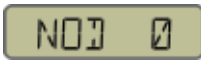

LED Status	LED 1	LED 2
● Green ON	—	—
● Green FLASHING	RF Link OK	—
● Red ON	System Error	System Error
● Red FLASHING	—	No RF Link with Gateway (out of sync)



Quick Start: **STEP 5** > Site Survey (optional)

A site survey determines the quality of the link between a Gateway and a given Node. The **Gateway** is used to perform a site survey.

NOTE: The Site Survey should be performed prior to the permanent installation of your network to ensure robust communication.

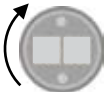
	User Action	Display/Status	Notes
SITE SURVEY MENU	Remove Gateway rotary switch access cover. 		
	Change right rotary switch setting to 1 		The Gateway is enabled to read the status of Node 1 and the display will now scroll through the Node's I/O status
	Single-click Gateway push button 1 		Device Information menu
	Single-click Gateway push button 1 		Factory Settings menu
	Single-click Gateway push button 1 		Site Survey menu
	Single-click Gateway push button 2 		Site Survey will be conducted with Node 1
	Single-click Gateway push button 2 		The Gateway analyzes the quality of signal from the Node by counting the number of data packets it receives from the Node. M = Missed packet R = RED marginal signal, Y = YELLOW good signal, G = GREEN excellent signal Install devices in positions that optimize the number of YELLOW and GREEN data packets received.
SURVEY READINGS	Examine reception readings (M,R,Y,G) of the Gateway at various locations		
			
			
RETURN TO RUN MODE	Double-click Gateway push button 2 		End Site Survey
	Change right rotary switch back to 0 (Gateway) 		Change the device readings back to the Gateway
	Double-click Gateway push button 2 		Move back to the top level menu
	Single-click Gateway push button 1 		Return to RUN mode 
	Single-click Gateway push button 1 		
	Single-click Gateway push button 1 		
	Install Gateway rotary switch access cover. 		

Host Network – Gateway

Installing a host-connected network is similar to installing a standard DX80 wireless system, except that all device I/O for the Gateway and each Node can be accessed by a Modbus RTU Master device via serial RS485. (See pages 4-6 for instruction to Apply Power, Verify Communications, Conduct a Site Survey.) Follow this procedure if it is necessary to change the Gateway Slave ID, Baud Rate and Parity.

All steps (Power up, Site Survey, Applying Devices) are identical to the stand-alone system procedures, except that the Gateway has no hard-wired inputs or outputs enabled or linked. Instead, all device I/O of the Gateway and each Node can be accessed by a Modbus RTU Master device via serial RS485. In order to accomplish this, you may first need to configure several system-level communications parameters on the DX80 Gateway (in addition to the serial hookups shown below).

Parameter	Description
Slave ID (default = 1)	Defines the slave number (1) for the serial Modbus RTU protocol.
Baud Rate (default = 19200)	Defines communication data rate (19.2, 38.4 or 9.6 kbps) between the Gateway and the Host through the serial interface.
Parity (default = none)	Defines serial parity (none, even, or odd) between Gateway and Host.

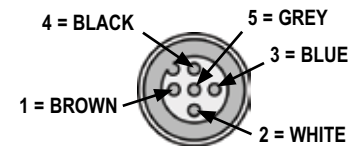

Wiring: 5-pin Euro pinouts for 485+, 485- and Comms ground

Brown	1	10-30V dc Input
White	2	RS 485 / D1 / B / +
Blue	3	Ground Input
Black	4	RS485 / D0 / A / -
Grey	5	Comms Gnd

Host Network – Gateway (cont.)

Setting the Slave ID

Similar to Network ID, the Slave ID parameter can be changed in the Device Configuration (*DVCFG) system menu option. Follow the Top Level System Menu through *DVCFG to the Slave ID (SLID) parameter. The LCD will display an alternating Current value and New value for the parameter.

	User Action	Display/Status	Notes
SET SLAVE ID	On the Gateway, move to the "Device Configuration" menu		To navigate to the *DVCFG (Device Configuration) menu, see page 12.
	Single-click Gateway push button 2		
	Single-click Gateway push button 1		Moves to the Slave ID field, default value is 1
	Single-click Gateway push button 2		The new Slave ID is defined by the current position of the rotary switches.
	Set rotary switches to the desired new Slave ID		Select between 01 to 99
	Single-click Gateway push button 2		Slave ID is saved
SET BAUD RATE	Single-click Gateway push button 1		Moves to the BAUD rate field
	Single-click Gateway push button 2		
	Single-click Gateway push button 1		Options are 9600, 19200, 38400, default is 19200
	Single-click Gateway push button 2		Baud rate is saved.
	Single-click Gateway push button 1		Moves to the Parity field
	Single-click Gateway push button 2		
SET PARITY	Single-click Gateway push button 1		Options are NONE, EVEN, ODD, default is NONE
	Single-click Gateway push button 2		Parity setting is saved.
	Double-click Gateway push button 2		Returns to Device Configuration menu
	Click Gateway push button 1 through to *RUN		
	Adjust Left rotary switch back to NID value		

A wireless network can be hindered by radio interference and obstructions in the path between a receiver and transmitter.

To achieve the best radio performance, installation locations for Gateways and Nodes should be carefully considered.

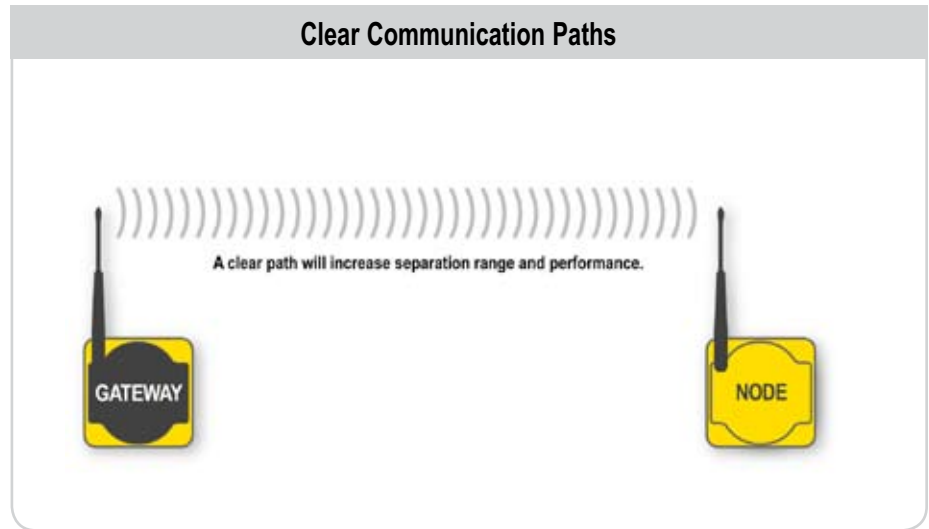

The external antenna should be vertically-oriented for optimal RF communication. In addition, consider the height of DX80 position to improve reception levels.

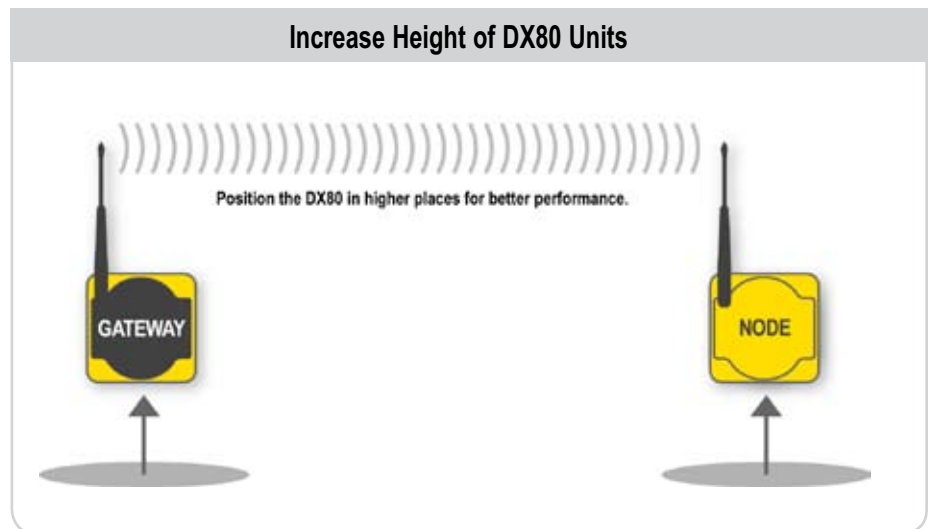

DX80 Gateway & Node Dimensions

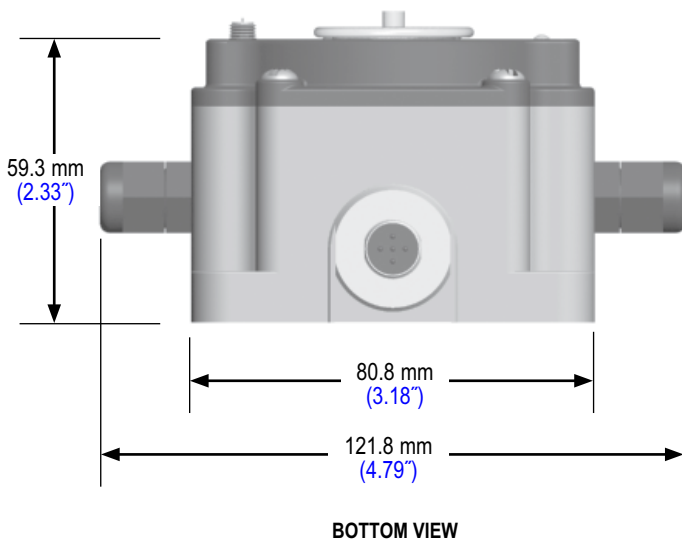
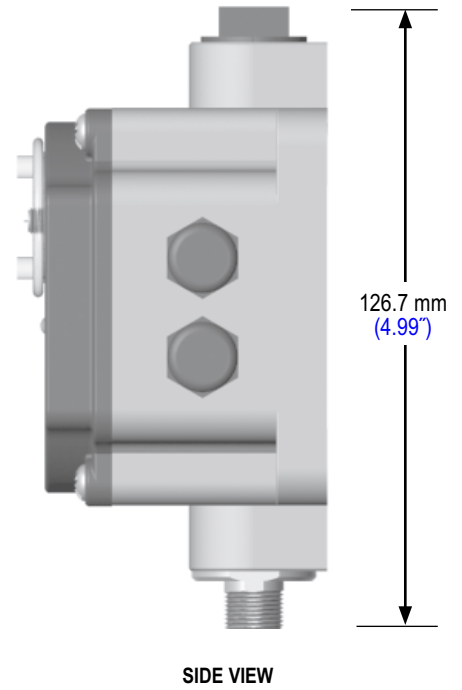
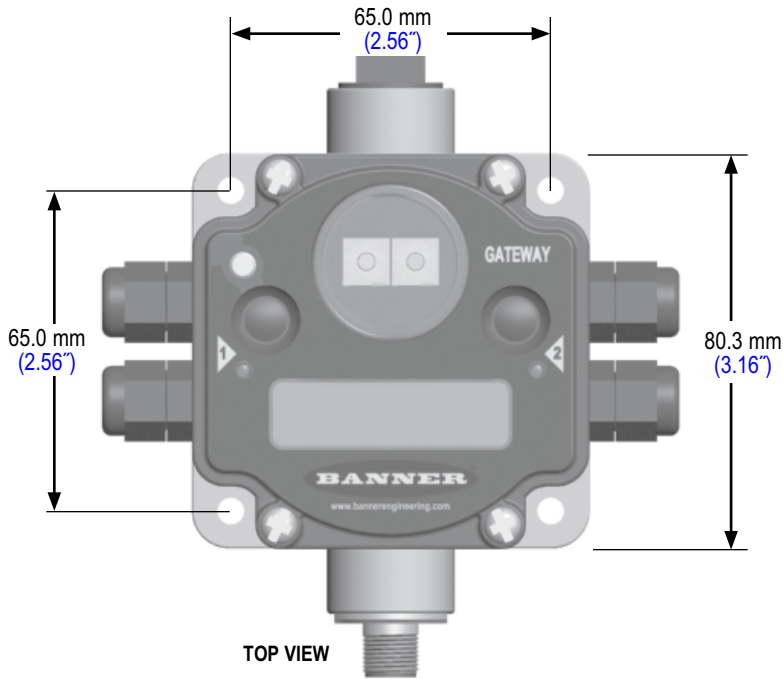

DX80 Gateway Setup Menu

When power is applied, the DX80 immediately enters RUN state (Gateway or Node). Run state is the normal operating mode for all devices on the wireless network.

From Run Mode, Single-click Button 1 to advance through top-level menu
 To return to Run Mode from any position, Double-click Button 2 twice †

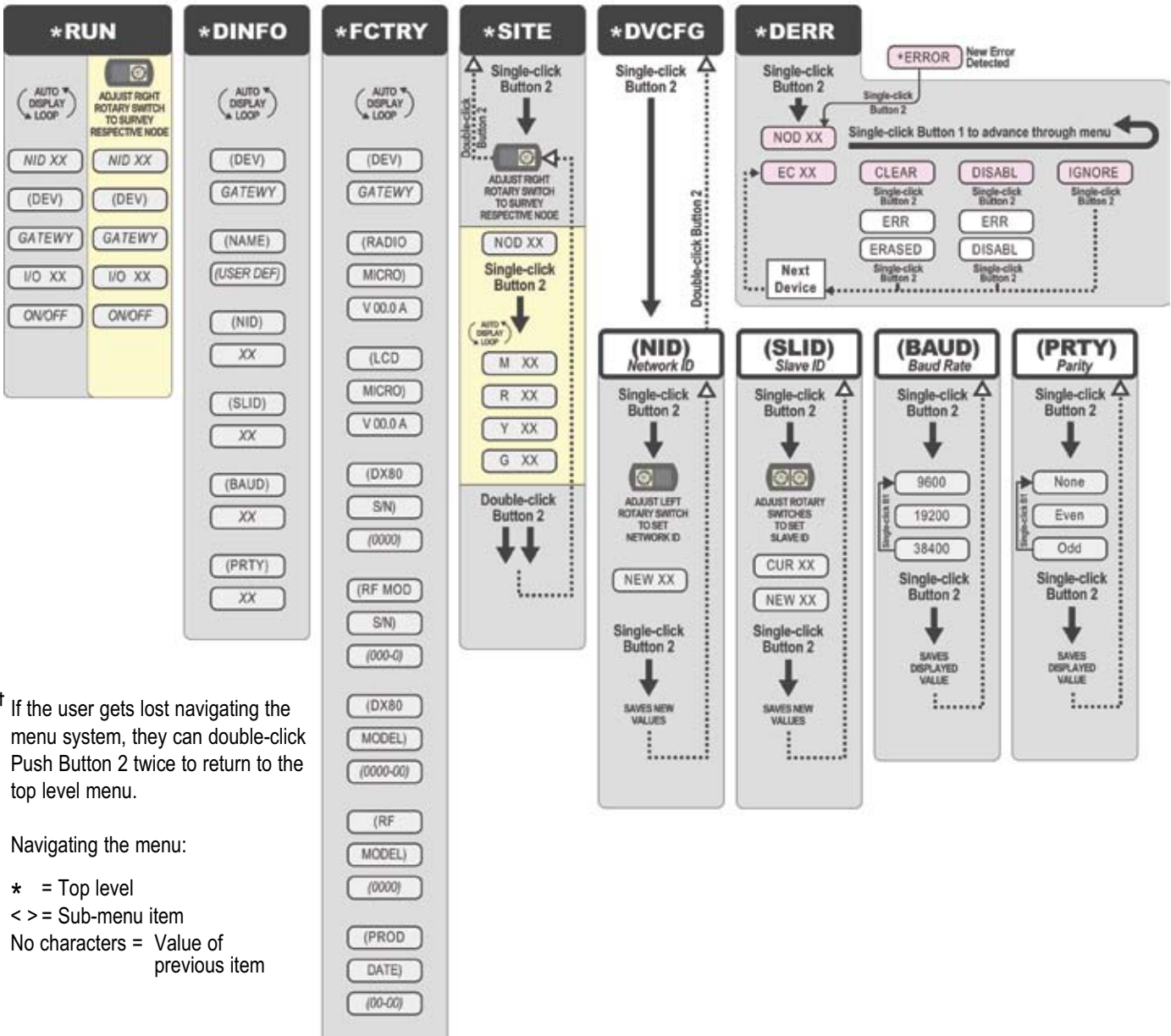

† If the user gets lost navigating the menu system, they can double-click Push Button 2 twice to return to the top level menu.

Navigating the menu:
 * = Top level
 < > = Sub-menu item
 No characters = Value of previous item

DX80 Node Setup Menu

When power is applied, the DX80 immediately enters RUN mode (Gateway or Node). RUN mode is the normal operating mode for all devices on the wireless network.

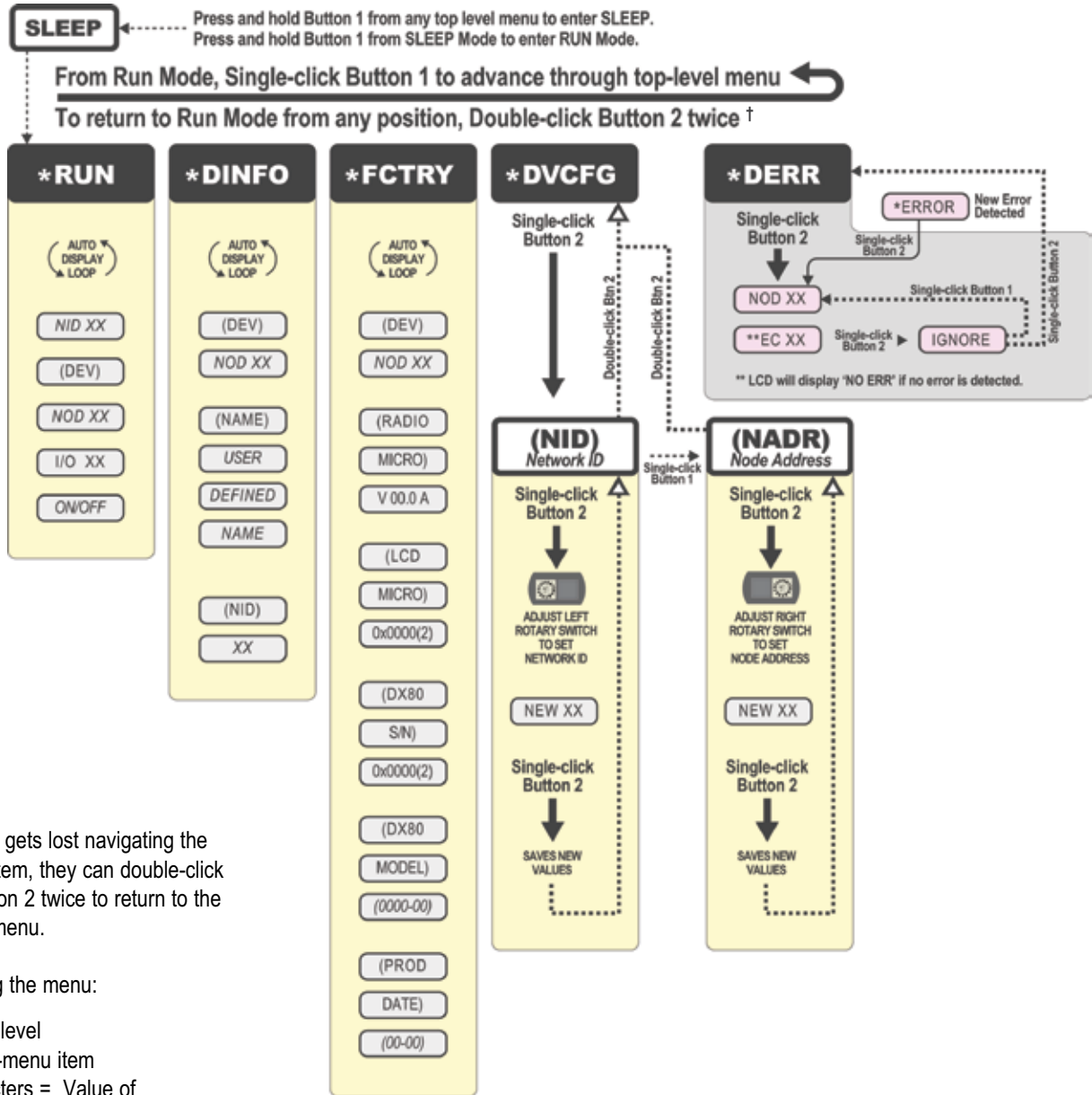

† If the user gets lost navigating the menu system, they can double-click Push Button 2 twice to return to the top level menu.

Navigating the menu:

- * = Top level
- < > = Sub-menu item
- No characters = Value of previous item

Node LCD Timeout: Press any button to refresh the display if the Node has entered this energy-saving mode.

RF Link Time-out & Recovery

Banner DX80 wireless devices employ a deterministic link time-out method to address RF link interruption or failure. As soon as a specific Node/Gateway RF link times out, all pertinent wired outputs are de-energized until the link is recovered (see kit-specific Supplemental Sheet for more information). Through this process, users of Banner wireless networks can be assured that disruptions in the communications link will result in predictable system behavior.

Link time-out utilizes a fully-acknowledged polling method to determine RF link status of each Node on the network. If after a prescribed number of sequential polling cycles the Node does not acknowledge a message, the Gateway considers the link with the Node to be timed out. LCD displays on both the Node and Gateway will show *ERROR. Following a time-out, the Node de-energizes outputs; the Gateway (or Repeater Node, if applicable) sets all outputs linked to the Node in question to a de-energized state, as well.

Once a link has been faulted, the Gateway must receive a number of good packets from the Node in question (with some hysteresis to prevent link "toggling") for the link to be reinstated. If the DX80 network is *not* Host-connected (RS485 serial access not enabled), outputs are restored to current values when the link is recovered.

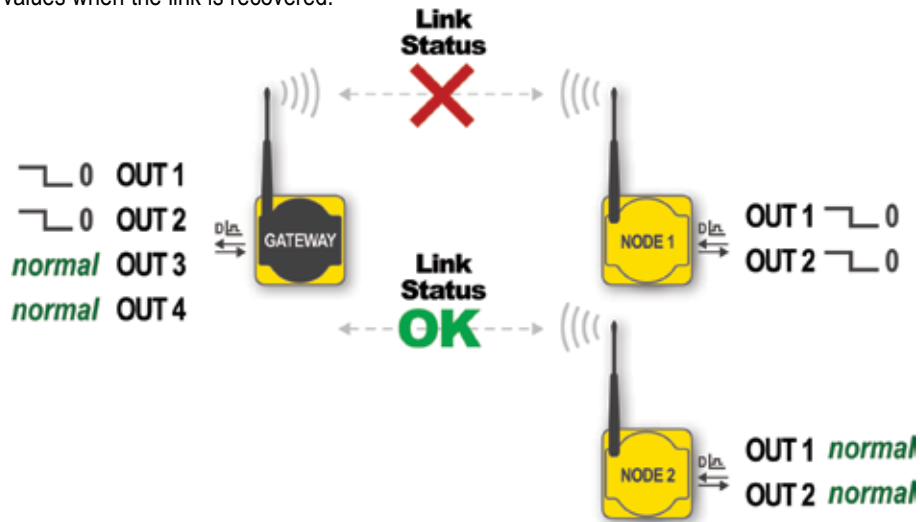

Link between Gateway and Node 1 timed out.

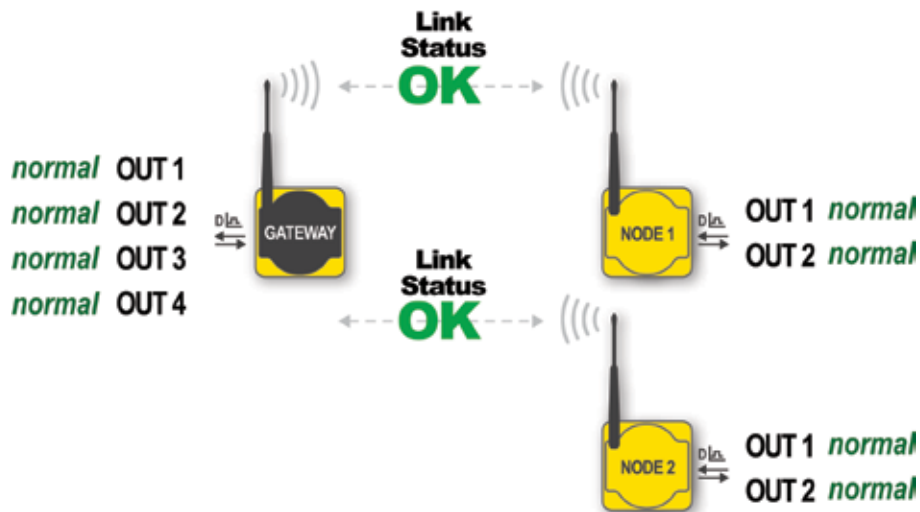

Link between Gateway and Node 1 recovered.

RF Link Time-out & Recovery – Host-connected

In a Host-connected DX80 system, a link time-out will result in an error code (53 or 0x35xx) being placed in the Node-specific DEVICE MESSAGE Modbus register (Node 1 = Register 24, Node 2 = Register 40, etc.).

In order for the RF link to be reinstated, the Host must send a control message to clear the device error message. Any Node output registers will be re-populated by the latest Gateway register map.

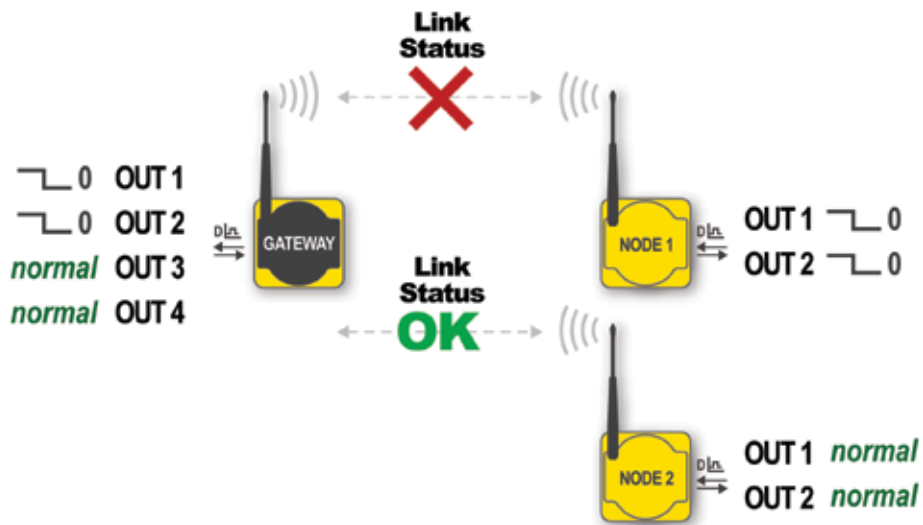

Link between Gateway and Node 1 timed out.

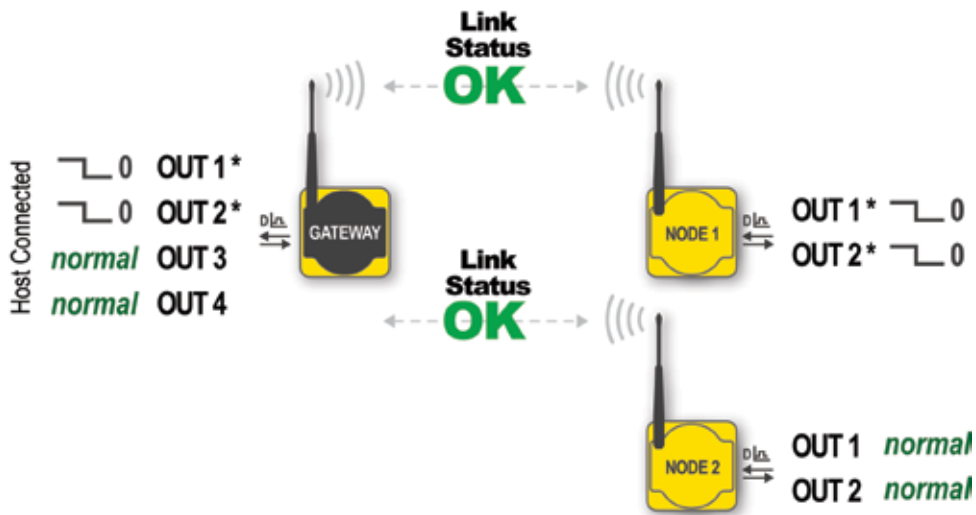

Link between Gateway and Node 1 recovered.

* It is the responsibility of the Host to handle Node device error messages. This will result in outputs being reinstated.

Troubleshooting

A wireless network can be hindered by radio interference as well as obstructions in the path of the receiver and transmitter. To achieve the best radio performance possible, the installation locations for Gateways and Nodes should be carefully considered. In general, the need for a clear path becomes greater as the transmission distance increases. Use Site Survey (RSSI) to confirm signal quality before fixing devices for permanent installation.

Problem Description	Possible Solutions
Basic power-up issues	
No LEDs, No LCD display	<ul style="list-style-type: none"> DX80 devices should immediately display 'POWER' on the LCD for the first 5-10 seconds after power is applied. A DX80 Gateway will always have a green LED on when power is connected. DX80 Node devices will flash a red LED every 3 seconds or a green LED every second depending upon the RF Link status. Battery devices can be put into a power down mode using button 1 on the front panel. To put a battery device into power down mode, hold button 1 for 3-5 seconds. To make a battery device come out of power down mode, hold button 1 for 3-5 seconds. Recheck power connections and power requirements. Line powered devices require 10-30V DC. The DX81 Battery Module provides 3.6V DC.
DX80 devices will not Synchronize	
Node flashes the red LED (no sync)	<ul style="list-style-type: none"> There are two things that MUST be set on every Node device to make it synchronize with the Gateway device: <ol style="list-style-type: none"> The Network ID on the Node must match the Gateway Network ID. (0-15). Each node must have the rotary switches set to a unique number (1-15). Refer to "Getting Started – Multiple Networks, Setting Network ID" If the DX80 Gateway & Node are less than 2 meters apart the devices may not communicate properly (radios may saturate). The Gateway & Node may be too far apart to achieve sync – consult factory for options. Qualified antenna should be placed on both the Gateway and Node device. After system parameter changes it is a good idea to cycle power to cause a resyncing of the devices. If a Node device goes out of sync it is programmed to try to acquire sync for 5 seconds and then sleep for 15 seconds. Synchronizing may require up to 20 seconds. Recycle power on the Gateway & Node devices.
Site survey (RSSI) returns > 30 MISSED packets	
Marginal Site Survey (RSSI) results	<ul style="list-style-type: none"> If the distance between devices is greater than about 5,000 meters (3 miles) line of sight *OR* objects such as trees or man-made obstructions interfere with the path, and the MISSED packet count exceeds 30 per 100 packets, the following steps should be considered: DX80 units should be raised to a higher elevation – either by physically moving the devices, or installing the antenna(s) remotely at a higher position. Use high-gain antenna(s) such as Yagi and/or Omni (see Accessories). Decrease the distance between devices.
DX80 Gateway will not talk with the host system	
No communications with the DX80 Gateway using RS485	<ul style="list-style-type: none"> Default communications parameters for the RS485 are: 1 start bit, 8 data bits, no parity, 1 stop bit and 19.2k baud. The DX80 Gateway uses Modbus RTU protocol for all communications. The supported Modbus function codes are 3, 6, and 16. Make sure the DX80 model supports RS485 serial communications. Make sure the Slave ID is set properly for the bus environment. Factory default Slave ID = 1. Factory default for the Modbus timeout is set to 4 seconds (for Modbus kits only). If you are using this feature make sure the time is properly set. RS485 termination or biasing is not supplied on the DX80 Gateway and should be provided externally to the DX80. (Termination is not required by the DX80 Gateway, proper biasing of the serial lines is required.)
RF link time-out and recovery	
DX80 Display shows *ERROR	<ul style="list-style-type: none"> The Gateway utilizes fully-acknowledged polling to ensure each Node RF link is robust. Consequently, if after a prescribed number of sequential polling cycles are not acknowledged by a Node, the Gateway considers the particular link with that Node to be timed out. All outputs on the Node in question will be set to "OFF" (discrete) or "0" (analog, regardless of type). If the Node's RF link is recovered and the Gateway can determine that enough acknowledged polling messages have been accumulated, then the link is reinstated and outputs are restored to the current values.
I/O functionality	
Particular inputs and/or outputs are not working	<ul style="list-style-type: none"> Use manual scrolling mode within *RUN to freeze the I/O status on the LCD display for the device in question. Verify that when the input device changes state or changes value, the LCD mirrors the behavior. Also verify that the LCD on the output side mirrors the linked input's behavior. If the input device state, LCD on origination DX80, and LCD on destination DX80 all behave exactly the same, there may be a wiring issue or an interfacing problem. Consult factory.

Agency Certification

FCC Certification

The DX80 Module complies with Part 15 of the FCC rules and regulations.

FCC ID: UE300DX80-2400 This device complies with Part 15 of the FCC Rules. Operation is subject to the following two conditions: (1) this device may not cause harmful interference and (2) this device must accept any interference received, including interference that may cause undesired operation.

FCC Notices

IMPORTANT: The DX80 Modules have been certified by the FCC for use with other products without any further certification (as per FCC section 2.1091). Changes or modifications not expressly approved by the manufacturer could void the user’s authority to operate the equipment.

IMPORTANT: The DX80 Modules have been certified for fixed base station and mobile applications. If modules will be used for portable applications, the device must undergo SAR testing.

IMPORTANT: If integrated into another product, the FCC ID label must be visible through a window on the final device or it must be visible when an access panel, door or cover is easily removed. If not, a second label must be placed on the outside of the final device that contains the following text: Contains FCC ID:UE300DX80-2400

NOTE:

This equipment has been tested and found to comply with the limits for a Class B digital device, pursuant to Part 15 of the FCC Rules. These limits are designed to provide reasonable protection against harmful interference in a residential installation. This equipment generates uses and can radiate radio frequency energy and, if not installed and used in accordance with the instructions, may cause harmful interference to radio communications. However, there is no guarantee that interference will not occur in a particular installation. If this equipment does cause harmful interference to radio or television reception, which can be determined by turning the equipment off and on, the user is encouraged to try to correct the interference by one or more of the following measures:

- Reorient or relocate the receiving antenna.
- Increase the separation between the equipment and receiving module.
- Connect the equipment into an outlet on a circuit different from that to which the receiving module is connected.
- Consult the dealer or an experienced radio/TV technician for help.

Antenna Warning **WARNING:** This device has been tested with Reverse Polarity SMA connectors with the antennas listed in Table 1 Appendix A. When integrated into OEM products, fixed antennas require installation preventing end-users from replacing them with non-approved antennas. Antennas not listed in the tables must be tested to comply with FCC Section 15.203 (unique antenna connectors) and Section 15.247 (emissions).

FCC-Approved Antennas

WARNING: This equipment is approved only for mobile and base station transmitting devices. Antenna(s) used for this transmitter must be installed to provide a separation distance of at least 20 cm from all persons and must not be co-located or operating in conjunction with any other antenna or transmitter.

DX80 Module may be used only with Approved Antennas that have been tested with this module.

Part Number	Antenna Type	Maximum Gain
—	Integral antenna	Unity gain
TBD	1/2 wave dipole	≤2 dBi
TBD	Collinear	≤5 dBi
TBD	Coaxial	≤7 dBi

Table 1. Type certified Antenna

Notes



WARRANTY: Banner Engineering Corp. warrants its products to be free from defects for one year. Banner Engineering Corp. will repair or replace, free of charge, any product of its manufacture found to be defective at the time it is returned to the factory during the warranty period. This warranty does not cover damage or liability for the improper application of Banner products. This warranty is in lieu of any other warranty either expressed or implied.