

SIGMET RVP8 USERS GUIDE

1. Introduction and Specifications

The RVP8 Lineage

SIGMET Inc. has a 20-year history of supplying innovative, high-quality signal processing products to the weather radar community. The history of SIGMET products reads like a history of weather radar signal processing:

| Units Year | Model | Sold | Major Technical Milestones |
|---------------|-------|------|--|
| 1981 | FFT | 10 | First commercial FFT-based Doppler signal processor for weather radar applications. Featured Simultaneous Doppler and intensity processing. |
| 1985 | RVP5 | 161 | First single-board low-cost Doppler signal processor. First commercial application of dual PRF velocity unfolding algorithm. |
| 1986 | PP02 | 12 | First high-performance commercial pulse pair processor with 18.75-m bin spacing and 1024 bins. |
| 1992 | RVP6 | 150 | First commercial floating-point DSP-chip based processor. First commercial processor to implement selectable pulse pair, FFT or random phase 2nd trip echo filtering. |
| 1996 | RVP7 | >200 | First commercial processor to implement fully digital IF processing for weather radar. |
| 2003 | RVP8 | | First digital receiver/signal processor to be implemented using an open hardware and software architecture on standard PC hardware under the Linux operating system. Public API's are provided so that customers may implement their own custom processing algorithms. |

Much of the proven, tested, documented software from the highly-successful RVP7 (written in C) is ported directly to the new RVP8 architecture. This allows SIGMET to reduce time-to-market and produce a high-quality, reliable system from day one. However, the new RVP8 is not simply a re-hosting of the RVP7. The RVP8 provides new capabilities for weather radar systems that, until now, were not available outside of the research community.

Advanced Digital Transmitter Option

For example, the RVP8 takes the next logical step after a digital receiver- a digitally synthesized IF transmit waveform output that is mixed with the STALO to provide the RF waveform to the transmitter amplifier (e.g., Klystron or TWT). The optional RVP8/Tx card opens the door for advanced processing algorithms such as pulse compression, frequency agility and phase agility that were not possible before, or done in more costly ways.

Open Hardware and Software Design

Compared to previous processors that were built around proprietary DSP chips, perhaps the most innovative aspect of the RVP8 is that it is implemented on standard PC hardware and software that can be purchased from a wide variety of sources. The Intel Pentium/PCI approach promises continued improvement in processor speed, bus bandwidth and the availability of low-cost compatible hardware and peripherals. The performance of an entry level RVP8 (currently dual 2.4 GHz Pentium processors) is 6 times faster than the fastest RVP7 ever produced (with two RVP7/AUX boards).

Aside from the open hardware approach, the RVP8 has an open software approach as well. The RVP8 runs in the context of the Linux operating system. The code is structured and public API's are provided so that research customers can modify/replace existing SIGMET algorithms, or write their own software from scratch using the RVP8 software structure as a foundation on which to build.

The advantage of the open hardware and software PCI approach is reduced cost and the ability for customers to maintain, upgrade and expand the processor in the future by purchasing standard, low cost PC components from local sources.

SoftPlane High-Speed I/O Interconnect

There are potentially many different I/O signals emanating from the backpanel of the RVP8. Most of these conform to well-known electrical and protocol standards (VGA, SCSI, 10-BaseT, RS-232 Serial, PS/2 Keyboard, etc.), and can be driven by standard commercial boards that are available from multiple vendors. However, there are other interface signals such as triggers and clocks that require careful timing. These precise signals cannot tolerate the PCI bus latency. For signals that are achieved with a dedicated wire, the RVP8 Softplane provides the solution. Physically, the Softplane is a 16-wire digital "daisy-chain" bus that plugs into the tops of the RVP8/Rx, RVP8/Tx, and I/O boards. The wires connect to the FPGA chips on each card, and the function of each wire is assigned at run-time based on the connectivity needs of the overall system. The Softplane allocates a dedicated wire to carry each high-speed signal; but groups of medium-speed signals are multiplexed onto single wires in order to conserve resources. Even though there are only 16 wires available, the Softplane is able to carry several high-speed signals and hundreds of medium-speed signals, as long as the total bandwidth does not exceed about 600Mbits/sec.

The Softplane I/O is configured at run-time based on a file description rather than custom wiring such as wirewrap. Neither the PCI backplane nor the physical Softplane are customized in any way. Since there is no custom wiring, a failed board can be replaced with a generic off-the-shelf spare, and that spare will automatically resume whatever functions had been assigned to the original board. Similarly, if the chassis itself were to fail, then simply plugging the boards into another generic chassis would restore complete operation. Cards and chassis can be swapped between systems without needing to worry about custom wiring.

Standard LAN Interconnection for Data Transfer or Parallel Processing

For communication with the outside world, the RVP8 supports as standard a 10/100/1000 Base T Ethernet. For most applications, the 100 BaseT Ethernet is used to transfer moment results (Z, T, V, W) to the applications host computer (e.g., a product generator). However, the gigabit Ethernet is sufficiently fast to allow UDP broadcast of the I and Q values for the purpose of archiving and/or parallel processing. In other words, a completely separate signal processor can ingest and process the I and Q values generated by the RVP8.

1.1 System Configuration Concepts

The hardware building blocks of an RVP8 system are actually quite few in number:

- ◆ **RVP8/IFD** ◆ **IF Digitizer Unit**-This is a separate sealed unit usually mounted in the receiver cabinet. The primary input to the IFD is the received IF signal. In addition, the IFD has channels to sample the transmit pulse and to take in an external clock to phase lock the A/D conversion with the transmit pulse (not used for magnetron systems).
- ◆ **RVP8/Rx** ◆ **Card**-A PCI card mounted in the chassis. It connects to the IFD by a CAT-5E cable which can be up to 25m long. In addition, there are two BNC trigger outputs and four RS-422 programmable I/O signals.
- ◆ **I/O-62** ◆ **Card and Connector Panel**-These handle all of the various I/O associated with a radar signal processor, such as triggers, antenna angles, polarization switch controls, pulse width control, etc. The Connector Panel is mounted on either the front or rear of the equipment rack and a cable (supplied) connects the panel to the I/O-62.
- ◆ **Optional RVP8/Tx** ◆ **card**-This supplies two IF output signals with programmable frequency, phase and amplitude modulation. In the simplest case it might merely supply the COHO which is mixed with the STALO to generate the transmit RF for Klystron or TWT systems. More interesting applications include pulse compression and frequency agility scanning. This card is not necessary for magnetron systems.
- ◆ **PC Chassis and Processor with various peripherals**- a robust 4U rack mount unit with a dual-Xeon mother board, diagnostic front panel display, disk (mechanical or flash), CDRW, keyboard, mouse and optional monitor for local diagnostic work. Redundant power supplies are used, and there are redundant fans as well.

This modular hardware approach allows the various components to be mixed and matched to support applications ranging from a simple magnetron system to an advanced dual polarization system with pulse compression. Typically SIGMET supplies turn-key systems, although some OEM customers who produce many systems purchase individual components and integrate them by themselves. This allows OEM customers to put their own custom “stamp” on the processor and even their own custom software if they so choose.

For the turnkey systems provided by SIGMET, the basic chassis is a 6U rack mount unit as described above. A 2U chassis can be provided for applications for which space is limited. A very low cost approach is to use a desk side PC, but this is not recommended for applications that require long periods of unattended operation.

To illustrate various RVP8 configurations, some typical examples are shown below. For clarity, all the examples show the single-board computer approach. A mother board approach is equivalent.

Example 1: Basic Magnetron System

The building blocks required to construct the basic system are:

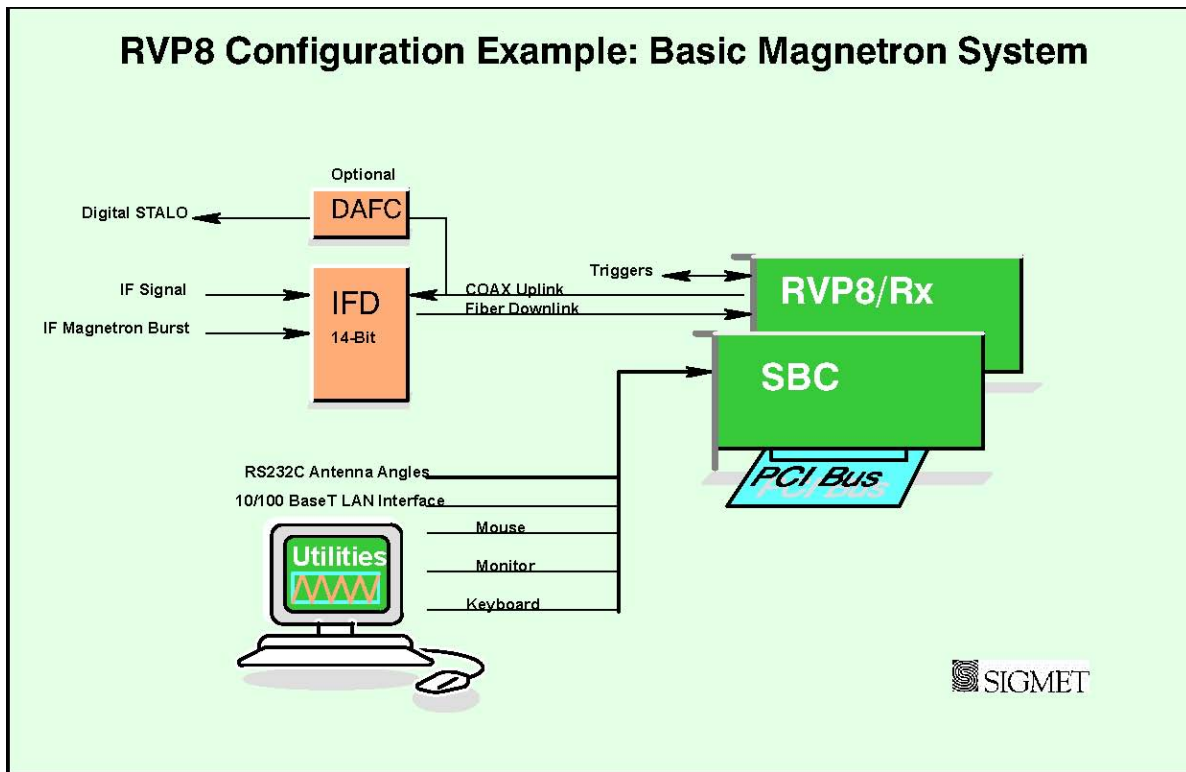

IFD- IF Digitizer installed in the radar receiver cabinet. This can be located up to 100 meters from the RVP8 main chassis (fiber optic connection). The DAFC (Digital AFC) is an option to interface to a digitally controlled STALO. Like the RVP7, the RVP8 provides full AFC with burst pulse auto-tracking.

RVP8/Rx- The digital receiver collects digitized samples from the IFD and does the processing to obtain I/Q. It also provides two trigger connections configurable for input or output.

SBC Card- Single Board Computer with dual SMP processors (PC) running Linux.

The figure above shows a basic magnetron system constructed with an IFD, and two PCI cards. A standard RS-232 serial input (included with the SBC) is used for obtaining the antenna angles and the output/input trigger is provided directly from the Rx card. This system has 5 times the processing power of the fastest version of the previous generation processor (RVP7/Main board plus 2 RVP7/AUX boards) so that it is capable of performing DFT processing in 2048 rangebins with advanced algorithms such as random phase 2nd trip echo filtering and recovery.

Example 2: Klystron System with Digital Tx

In this case, the IFD can receive a master clock from the radar system (e.g., the COHO). This ensures that the entire system is phase locked. As compared to the previous example there are two additional cards shown in this example:

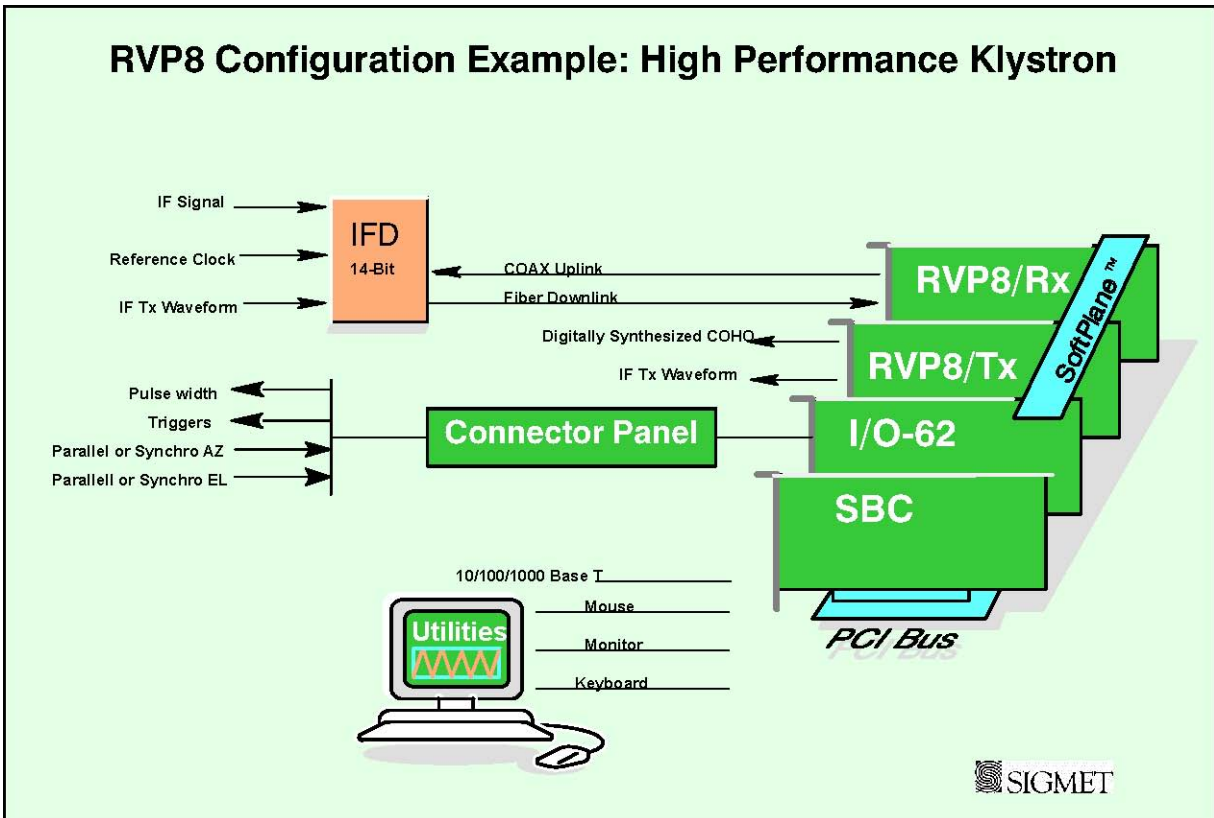

RVP8/Tx- The digital transmitter card provides the digital Tx waveform. A second output can be used to provide a COHO in the event that the RVP8 is used to provide the system master clock. In any case, the IF transit waveform and the A/D sampling are phase locked. **SIGMET I/O-62** card for additional triggers, parallel, synchro or encoder AZ and EL angle inputs, pulse width control, spot blanking control output, etc. These signals are brought in via the connector panel.

The figure shows the SIGMET SoftPlane[™] which carries time-critical I/O such as clock and trigger information which is not appropriate for the PCI bus. These signals are limited to the cards provided by SIGMET, i.e., the SoftPlane[™] is not connected to any of the standard commercial cards.

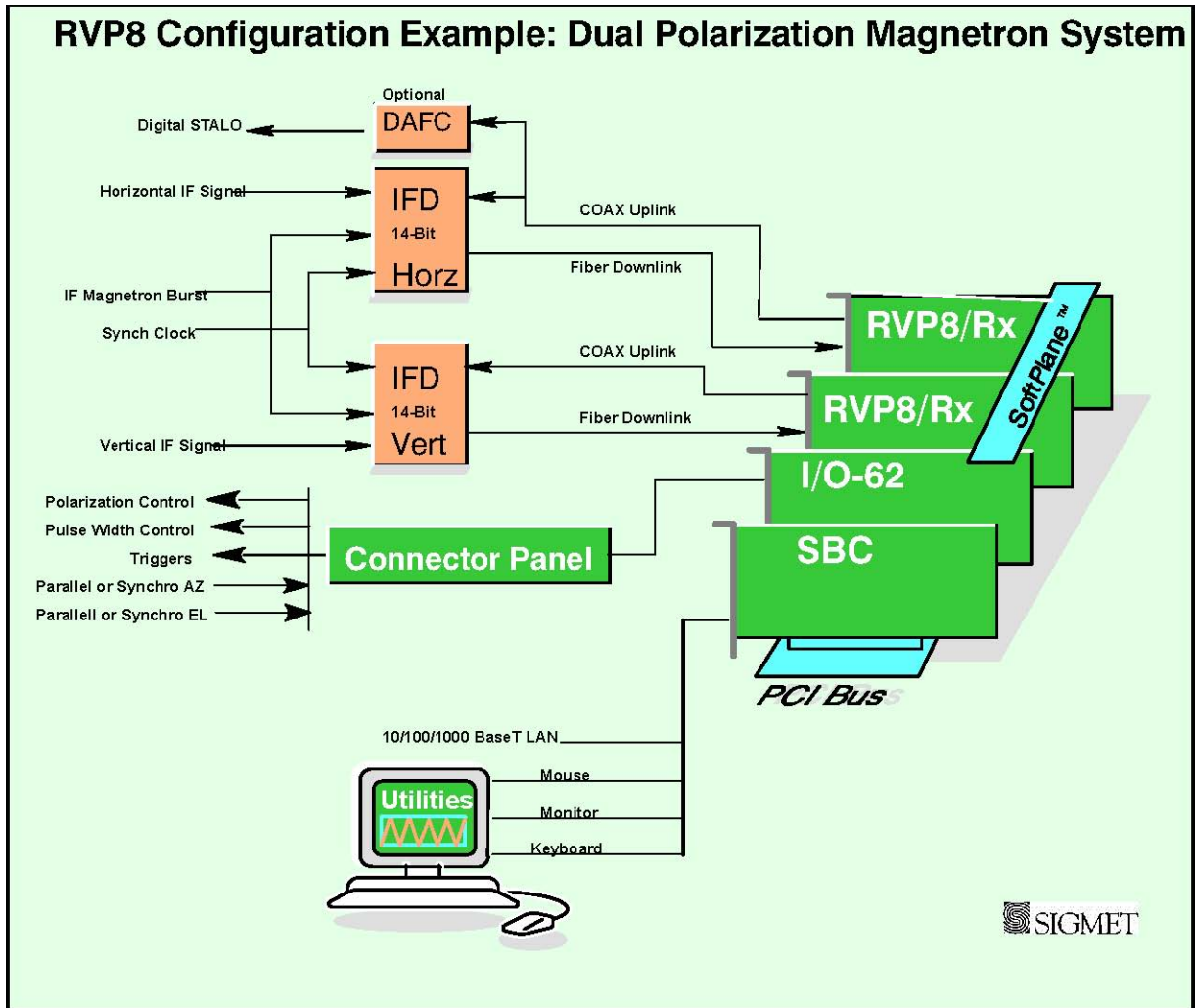

Example 3: Dual Polarization Magnetron System

In this system 2 IFD's and two RVP8/Rx cards are used for the horizontal and vertical channels of a dual-channel receiver. The legacy RVP7 technique of using a single IFD and two IF frequencies for the horizontal and vertical channels (e.g., 24 and 30 MHz) is also supported by the RVP8. In the case of either dual or single IFD's, there is a synch clock provided by either the STALO reference frequency (e.g., 10 MHz) or by the RVP8 itself.

The RVP8 supports calculation of the complete covariance matrix for dual pol, including ZDR, PHIDP (KDP), RHOHV, LDR, etc. Which of these variables is available depends on whether the system is a single-channel switching system (alternate H and V), a STAR system (simultaneous transmit and receive) or a dual channel switching system (co and cross receivers). Note that for the special case of a single channel switching system, only one IFD is required.

COTS Accessories

Aside from the basic PCI cards required for the radar application, there are additional cards that can be installed to meet different customer requirements, e.g.,

- 10/100–BaseT Ethernet card for additional network I/O (e.g., a backup network).
- RS-232/RS-422 serial cards for serial angles, remote TTY control, etc.
- Sound card to synthesize audio waveforms for wind profiler applications.
- GPS card for time synch.
- IEEE 488 GPIB card for control of test equipment.

The bottom line is that the PCI open hardware approach provides unparalleled hardware flexibility. In addition, the availability of compatible low-cost replacement or upgrade parts is assured for years into the future.

1.1.1 IFD IF Digitizer



The IFD 14-bit IF digitizer is a totally sealed unit for optimum low-noise performance. The use of digital components within the IFD is minimized and the unit is carefully grounded and shielded to make the cleanest possible digital capture of the input IF signal. Because of this, the IFD achieves the theoretical minimum noise level for the A/D convertors.

There are 4 inputs to the IFD:

IF video signal.

A secondary IF video signal, used for dual polarization or very wide dynamic range applications.

IF Burst Pulse for magnetron or IF COHO for Klystron.

Optional reference clock for system synchronization. For a Klystron system, the COHO can be input. Magnetron systems do not require this signal. This clock can even come from the RVP8/Tx card itself.

All of these inputs are on SMA connectors. The IF signal input is made immediately after the STALO mixing/sideband filtering step of the receiver where a traditional log receiver would normally be installed. The required signal level for both the IF signal and burst is +6.5 dBm for the strongest expected input signal. A fixed attenuator or IF amplifier may be used to adjust the signal level to be in this range.

Digitizing is performed for both the IF signal and burst/COHO channels at approximately 72 MHz to 14-bits. This provides 92 to 105 dB of dynamic range (depending on pulse width) without using complex AGC, dual A/D ranging or down mixing to a lower IF frequency.

All communication to the main RVP8 chassis goes over a special CAT5E type cable. The major volume of data is the raw time series samples sent down to the RVP8 Rx card. Coming back up is trigger timing and AFC information to the IFD.

The RVP8 provides comprehensive AFC support for tuning the STALO of a magnetron system. Alternatively, the magnetron itself can be tuned by a motorized tuning circuit controlled by the RVP8. Both analog (+10V) and digital tuning (with optional DAFC to 24 bits) are supported.

1.1.2 Digital Receiver PCI Card (RVP8/Rx)



The RVP8/Rx card receives the digitized IF samples from the IFD via the fiber optic link. The advantage of this design is that the receiver electronics (LNA, RF mixer, IF preamp, and IFD) can be located as far as 100–meters away from the RVP8 main chassis. This makes it possible to choose optimum locations for both the IFD and the RVP8, e.g., the IFD could be mounted on the antenna itself, and the processor box in a nearby equipment room.

The RVP8/Rx is 100% compatible with the 14-bit RVP7/IFD, but it also includes hooks for future IFD's operating at higher sampling clock rates. Two additional BNC connectors are included on the board's faceplate. These can be used for trigger input, programmable trigger output, or a simple LOG analog ascope waveform.

A remarkable amount of computing power is resident on the receiver board, in the form of an FIR filter array that can execute 6.9 billion multiply/accumulate cycles per second. These chips serve as the first stage of processing of the raw IF data samples. Their job is to perform the down–conversion, bandpass, and deconvolution steps that are required to produce (I,Q) time series. The time series data are then transferred over the PCI bus to the SBC for final processing.

The FIR filter array can buffer as much as 80 microsec of 36MHz IF samples, and then compute a pair of 2880–point dot products on those data every 0.83 microsec. This could be used to produce over-sampled (I,Q) time series having a range resolution of 125–meters and a bandwidth as narrow as 30Khz. The same computation could also yield independent 125–meter time series data from an 80 microsec compressed pulse whose transmit bandwidth was approximately 1MHz.

Finer range resolutions are also possible, down to a minimum of 25–meters. A special feature of the RVP8/Rx is that the bin spacing of the (I,Q) data can be set to any desired value between 25 and 2000 meters. Range bins are placed accurately to within +2.2 meters of any selected grid, which does not have to be an integer multiple of the sampling clock. However, when an integer multiple ($N \times 8.333$ –meters) is selected, the error in bin placement effectively drops to zero.

Dual polarization radars that are capable of simultaneous reception for both horizontal and vertical channels can be interfaced to the RVP8 using a separate RVP8/Rx and IFD for each channel. Note that the multiplexed dual IF approach used for the RVP7 with a single IFD can also be used.

One of the primary advantages of the digital receiver approach is that wide linear dynamic range can be achieved without the need for complex AGC circuits that require both phase and amplitude calibration.

Calibration Plot for RVP8/IFD

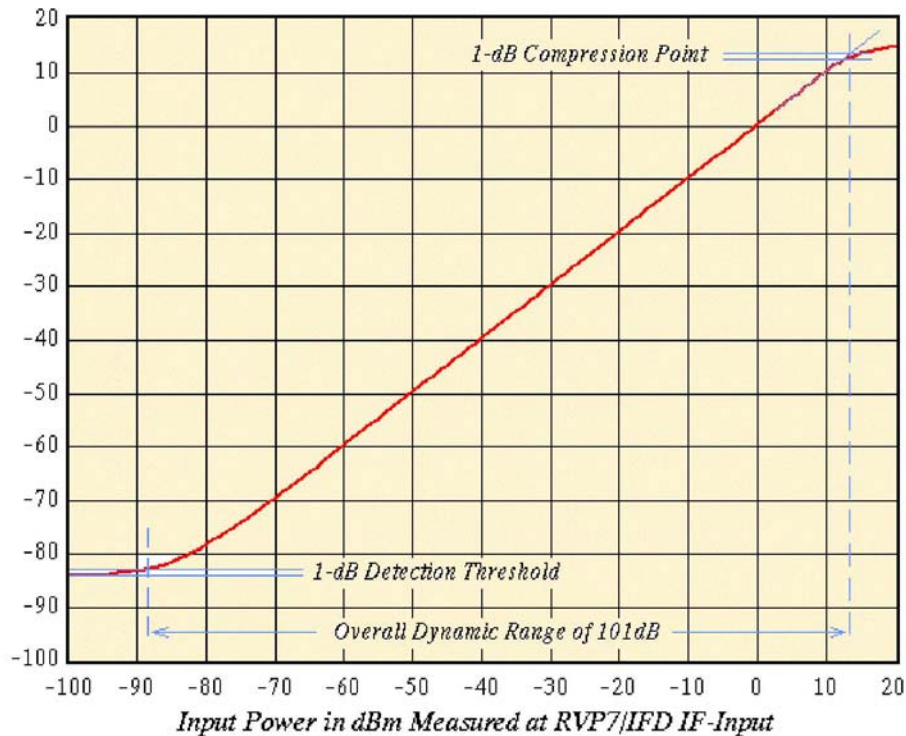

The figure above shows a calibration plot for a 14-bit IFD with the digital filter matched to a 2 microsecond pulse. The performance in this case is >100 dB dynamic range. The RVP8 performs several real time signal corrections to the I/Q samples from the Rx, including:

Amplitude Correction- A running average of the transmit pulse power in the magnetron burst channel is computed in real-time by the RVP8/Rx. The individual received I/Q samples are corrected for pulse-to-pulse deviations from this average. This can substantially improve the “phase stability” of a magnetron system to improve the clutter cancellation performance to near Klystron levels.

Phase Correction- The phase of the transmit waveform is measured for each pulse (either the burst pulse for magnetron systems or the Tx Waveform for coherent systems). The I/Q values are adjusted for the actual measured phase. The coherency achievable is better than 0.1 degrees by this technique.

Large Signal Linearization- When an IF signal saturates, there is still considerable information in the signal since only the peaks are clipped. The proprietary large signal linearization algorithm used in the RVP8 provides an extra 3 to 4 dB of dynamic range by accounting for the effects of saturation.

The RVP8/Rx card provides the same comprehensive configuration and test utilities as the RVP7, with the difference that no external host computer is required to run the utilities. These utilities can be run either locally or remotely, over the network! Some examples are shown below:

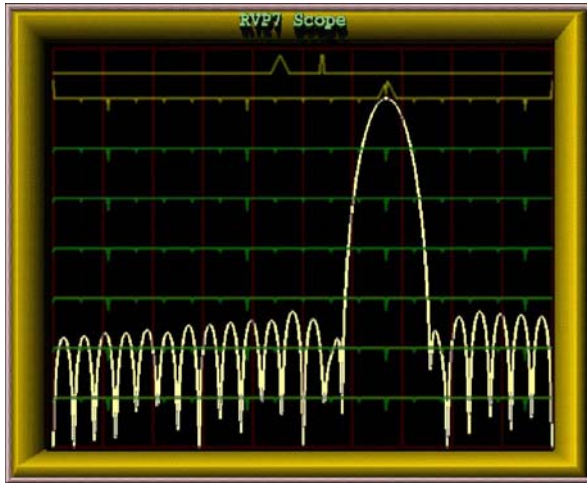

The built-in filter design tool makes it easy for anyone to design the optimal IF filter to match each pulse width and application. Simply specify the impulse response and pass band and the filter appears. The user interface makes it easy to widen/narrow the filter with simple keyboard commands. There is even a command to automatically search for an optimal filter.

This display can also show the actual spectrum of the transmit burst pulse for quality control and comparison with the filter.

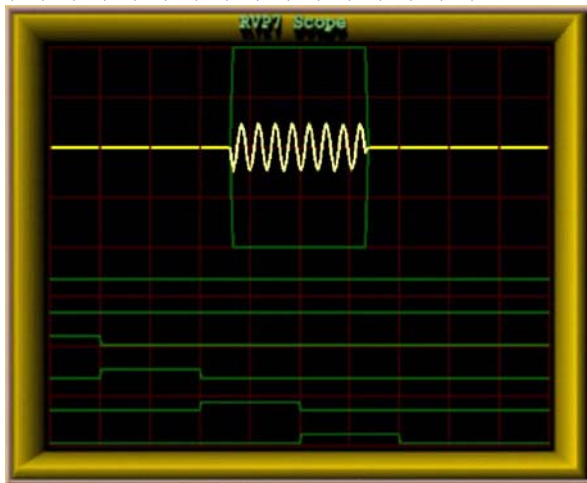

The quality assessment of the transmit burst pulse and its precise alignment at range zero are easy to do, either manually using this tool and/or automatically using the burst pulse auto-track feature. This performs a 2D search in both time and frequency space if a valid burst pulse is not detected. The automatic tracking makes the AFC robust to start-up temperature changes and pulse width changes that can effect the magnetron frequency.

AFC alignment/check is now much easier since it can be done manually from a central maintenance site or fully automatically.

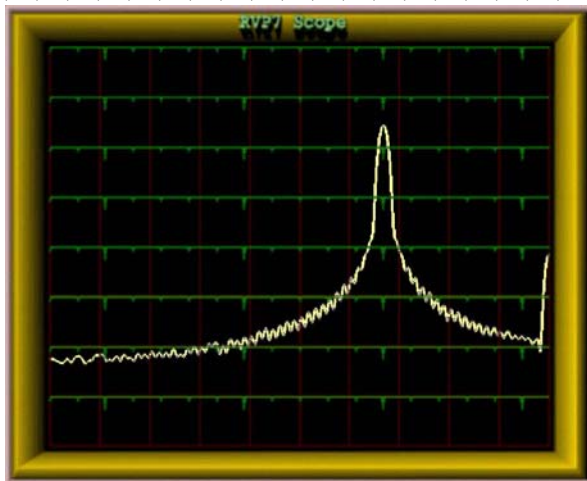

The RVP8 provides plots of the IF signal versus range as well as spectrum analysis of the signal as shown in this example.

In the past, these types of displays and tools required that a highly-skilled engineer transport some very expensive test equipment to the radar site. Now, detailed analysis and configuration can all be done from a central maintenance facility via the network. For a multi-radar network this results in substantial savings in equipment,

1.1.3 Mother Board or Single-Board Computer (SBC)



The dual-CPU Pentium mother board or single-board computer (SBC) acts as the host to the Linux operating system and provides all of the compute resources for processing the I/Q values that are generated by the RVP8/Rx card. Standard keyboard, mouse and monitor connections are on the Rx backpanel, along with a 10/100/1000 BaseT Ethernet port. The system does not require that a keyboard, mouse or monitor be connected which is typically the case at an unattended site. An SBC example is shown on the left.

Motherboards and SBC's are available from many vendors, at various speeds. Typically the SBC is equipped with 128 MB RAM. The RVP8 chassis has a front bay for either a >20 GB hard disk or a Flash Disk. The Flash Disk approach is well suited to applications where high-reliability is important. CDRW is also provided for software maintenance. Note that the latest versions of the RVP8 software and documentation can always be down-loaded from SIGMET's web site for FREE.

The SBC also plays host for SIGMET's RVP8 Utilities which provide test, configuration, control and monitoring software as well as built-in on-line documentation.

1.1.4 Digital Transmitter PCI Card (RVP8/Tx)



Many of the exciting new meteorological applications for the RVP8 are made possible by its ability to function as a digital radar transmitter. The RVP8/Tx PCI card synthesizes an output waveform that is centered at the radar's intermediate frequency. This signal is filtered using analog components, then up-converted to RF, and finally amplified for transmission. The actual transmitter can be a solid state or vacuum tube device. The RVP8 can even correct for waveform distortion by adaptively "pre-distorting" the transmit waveform, based on the measured transmit burst sample.

The Tx card has a BNC output for the IF Tx waveform. In addition, there is a second output for an auxiliary signal or clock, or for a clock input. At the bottom of the card is a 9-pin connector for arbitrary I/O (e.g., TTL, RS422, additional clock).

The RVP8 digital transmitter finds a place within the overall radar system that exactly complements the digital receiver. The receiver samples an IF waveform that has been down-converted from RF, and the transmitter synthesizes an IF waveform for up-conversion to RF. The beauty of this approach is that the RVP8 now has complete control over both halves of the radar, making possible a whole new realm of matched Tx/Rx processing algorithms. Some examples are given below:

- ◆ **Phase Modulation-** Some radar processing algorithms rely on modulating the phase of the transmitter from pulse to pulse. This is traditionally done using an external IF phase modulator that is operated by digital control lines. While this usually works well, it requires additional hardware and cabling within the radar cabinet, and the phase/amplitude characteristics may not

be precise or repeatable. In contrast, the RVP8/Tx can perform precise phase modulation to any desired angle, without requiring the use of external phase shifting hardware.

Pulse Compression-There is increasing demand for siting radars in urban areas that also happen to have strict regulations on transmit emissions. Often the peak transmit power is limited in these areas; so the job for the weather radar is to somehow illuminate its targets using longer pulses at lower power. The problem, of course, is that a simple long pulse lacks the ability (bandwidth) to discern targets in range. The remedy is to increase the Tx bandwidth by modulating the overall pulse envelope, so that a reasonable range resolution is restored. The exceptional fidelity of the RVP8/Tx waveform can accomplish this without introducing any of the spurious modulation components that often occur when external phase modulation hardware is used.

Frequency Agility- This has been well studied within the research community, but has remained out of the reach of practical weather radars. The RVP8/Tx changes all of this, because frequency agility is as simple as changing the center frequency of the synthesized IF waveform. Many new Range/Doppler unfolding algorithms become possible when multiple transmit frequencies can coexist. Frequency agility can also be combined with pulse compression to remedy the blind spot at close ranges while the long pulse is being transmitted.

COHO synthesis- The RVP8/Tx output waveform can be programmed to be a simple CW sine wave. It can be synthesized at any desired frequency and amplitude, and its phase is locked to the other system clocks. If you need a dedicated oscillator at some random frequency in the IF band, this is a simple way to get it.

1.1.5 I/O-62 PCI Card and I/O Panel

The SIGMET I/O-62 is a short format PCI card that provides extensive I/O capabilities for the RVP8. A typical installation would have one I/O-62 and an RVP8 Connector Panel shown above. The Softplane is used to interconnect the I/O 62 with other SIGMET PCI cards. Note that the identical card is used in the SIGMET RCP8 radar/antenna control processor which in general does not use the Softplane connection. The I/O-62 has a single 62-position, high-density “D” connector. This is attached to the RVP8 Connector Panel (typically mounted on the front or back of the rack which holds the RVP8). A standard 1:1 cable connects the remote panel to the I/O-62 card in the RCP8 chassis. The standard connector panel provided by SIGMET meets the needs of most radar sites.

The best part is that the I/O-62 is configurable in software, i.e., there is no need to open the chassis to configure jumpers or switches. This means that when a spare board is added, there is no need to perform hardware configuration or custom wiring.

The physical I/O lines are summarized in the system specifications section.

ESD Protection Features

Since the I/O lines are connected to the radar system, there is a potential for lightning or other ESD type damage. This is addressed aggressively by the I/O-62 in two ways:

- Every wire is protected by a **Tranzorb** diode which transitions from an open to a full clamp between 27 to 35 VDC. Additionally, the Connector Panel uses **Tranzorb** diodes on every I/O line for double protection.
- High-voltage tolerant front-end receivers/drivers are used. All components connected to the external pins can tolerate up to 40V. For example, the TTL and wide range inputs use protectors that normally look like 100 Ohm resistors, but open at high voltage.

Run Time FPGA Configuration

The SIGMET I/O-62 card is built around a 100K-Gate FPGA which, in addition to driving the I/O signals on the 62-position connector, also coordinates the PCI and Softplane traffic. These chips are SRAM-based, meaning that they are configured at run time. This allows the FPGA code to be automatically upgraded during each RVP8 code release without needing to physically reprogram any parts.

The board's basic I/O services use up only 40% of the complete FPGA. The leftover space makes it possible to add smart processing right on the I/O-62 board to handle custom needs. For example the 16-bit floating-point (I,Q) data in the previous example could be reformatted into a 32-bit fixed-point stream. Other examples include generating custom serial formats, data debouncing, and signal transition detection. In general, I/O functions that would either be tedious or inappropriate for the host computer SBC can likely be moved onto the I/O-62 card itself.

1.2 Comparison of Analog vs Digital Radar Receivers

1.2.1 What is a Digital IF Receiver?

A digital IF receiver accepts the analog IF signal (typically 30 MHz), processes it and outputs a stream of wide dynamic range digital “I” and “Q” values. These quantities are then processed to obtain the moment data (e.g., Z, V, W or polarization variables). Additionally, the digital receiver can accept the transmit pulse “burst sample” for the purpose of measuring the frequency, phase and power of the transmit pulse. The functions that can be performed by the digital receiver are:

- IF band pass filtering
- “I” and “Q” calculation over wide dynamic range
- Phase measurement and correction of transmitted pulse for magnetron systems – from burst sample
- Amplitude measurement and correction of transmitted pulse – from burst sample
- Frequency measurement for AFC output – from burst sample

The digital approach replaces virtually all of the traditional IF receiver components with flexible software-controlled modules that can be easily adapted to function for a wide variety of radars and operational requirements.

The digital receiver approach made a very rapid entry into the weather radar market. Up until the about 1997 weather radars were not supplied with digital receivers. Today in 2003 nearly all new weather radars and weather radar upgrades use the digital receiver approach. Much of this rapid change is attributed to the previous generation RVP7 which is the most widely sold weather radar signal processor of all time.

The number one advantage of a digital receiver is that it achieves a wide linear dynamic range (e.g., >95dB depending on pulse width) without having to use AGC circuits which are complex to build, calibrate and maintain. However, there are other advantages as well:

- Lower initial cost by eliminating virtually all IF receiver components.
- Lower life cycle cost do to reduced maintenance.
- Selectable IF frequency.
- Software controlled AFC with automatic alignment.
- Programmable band pass filter
- Dual or multiple IF multiplexing
- Improved remote monitoring down to the IF level.

The following sections compare the digital receiver approach to the analog receiver approach. This illustrates the advantages of the digital approach and what functions are performed by a digital receiver.

1.2.2 Magnetron Receiver Example

A typical analog receiver for a magnetron system is shown in the top portion of Figure 1–1. The received RF signal from the LNA is first mixed with the STALO (RF–IF) and the resulting IF signal is applied to one of several bandpass filters that match the width of the transmitted pulse. The filter selection is usually done with relays. The narrow band waveform is then split. Half is applied to a LOG amplifier having a dynamic range of 80–100dB, from which a calibrated measurement of signal power can be obtained. The LOG amplifier is required because it is almost impossible to build a linear amplifier with the required dynamic range. However, phase distortion within the LOG amplifier renders it unsuitable for making Doppler measurements; hence, a separate linear channel is still required.

The linear amplifier is fed from the other half of the bandpass filter split. It may be preceded by a gain control circuit (IAGC) which adjusts the instantaneous signal strength to fall within the limited dynamic range of the linear amplifier. The amplitude and phase characteristics of the IAGC attenuator must be calibrated so that the “I” and “Q” samples may be corrected during processing.

The IF output from the linear amplifier is applied to a pair of mixers that produce “I” and “Q”. The mixer pair must have very symmetric phase and gain characteristics, and each must be supplied with an accurate 0-degree and 90-degree version of the Coherent Local Oscillator (COHO). The later is usually obtained by sampling a portion of the transmitted pulse, and then phase locking an oscillator (COHO) that continues to “ring” afterward. Phase locked COHO’s of this sort can be very troublesome – they often fail to lock properly, drift with age, and fail to maintain coherence over the full unambiguous range.

The transmit burst that locks the COHO is also used by the Automatic Frequency Control (AFC) loop. The AFC relies on an FM discriminator and low pass filter to produce a correction voltage that maintains a constant difference between the magnetron frequency and the reference STALO frequency. The AFC circuit is often troublesome to set and maintain. Also, since it operates continuously, small phase errors are continually being introduced within each coherent processing interval.

In contrast, the RVP8 digital receiver is shown in to lower portion of Figure 1–1. The only old parts that still remain are the microwave STALO oscillator, and the mixer that produces the transmit burst. The burst pulse and the analog IF waveform are cabled directly into the IFD on SMA coax cables. Likewise, the AFC control voltage is also a simple direct connection either with analog tuning (+–10V from IFD) or digital control via the optional DAFC interface. These cables constitute the complete interface to the radar’s internal signals; no other connections are required within the receiver cabinet.

Figure 1-1: Analog vs Digital Receiver for Magnetron Systems
Classic Analog Receiver for Magnetron

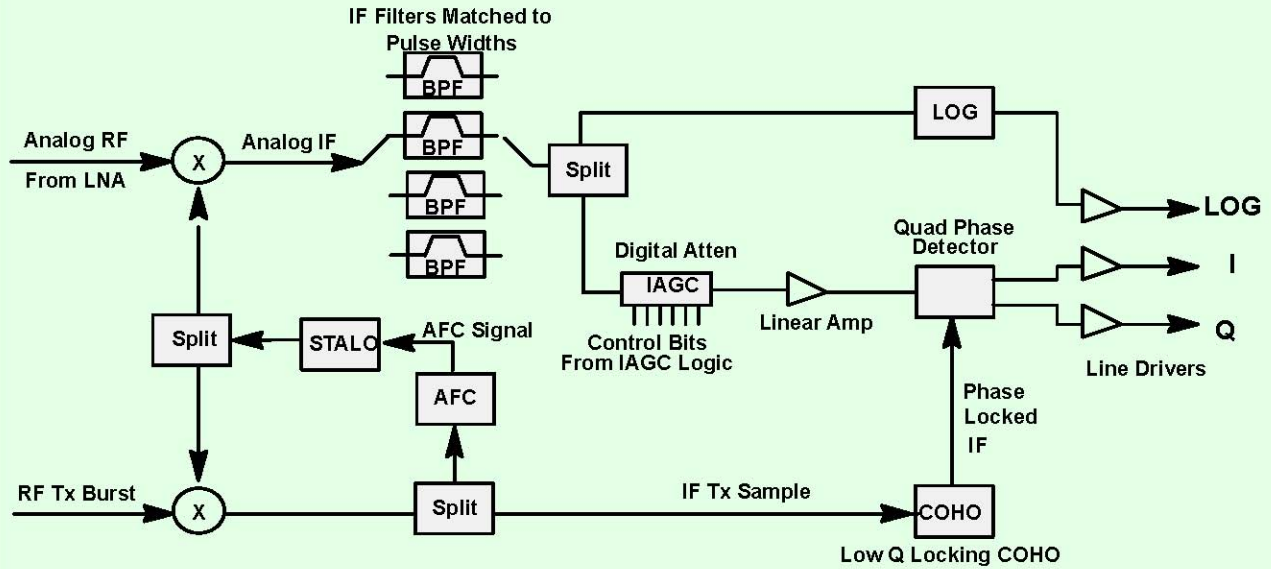

RVP8 Magnetron Interface

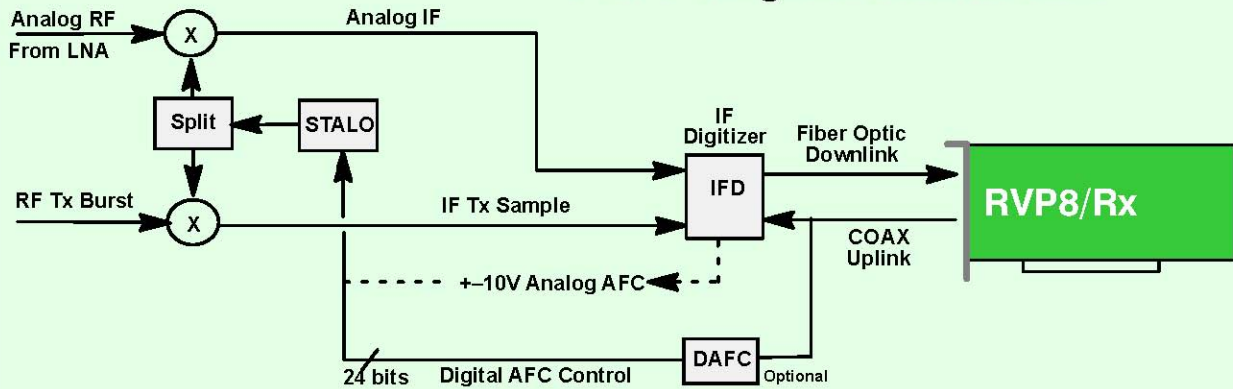

1.2.3 Klystron or TWT Receiver and Transmit RF Example

A typical analog receiver for a klystron system is shown in the top portion of Figure 1–2. The arrangement of components is similar to the magnetron case, except that the COHO operates at a fixed phase and frequency, a phase shifter is included for 2nd trip echo filtering and there is no AFC feedback required. The phase stability of a Klystron system is better than a magnetron, but the system is still constrained by limited linear dynamic range, IAGC inaccuracy, quad phase detector asymmetries, phase shifter inaccuracies, etc.

The RVP8/Tx card now plays the role of a programmable COHO. The digitally synthesized transmit waveform can be phase, frequency and amplitude modulated (no separate phase shifter is required) and even produce multiple simultaneous transmit frequencies. These capabilities are used to support advanced algorithms, e.g., range/velocity ambiguity resolution or pulse compression for low power TWT systems.

Figure 1–2: Analog vs Digital Receiver for Klystron Systems

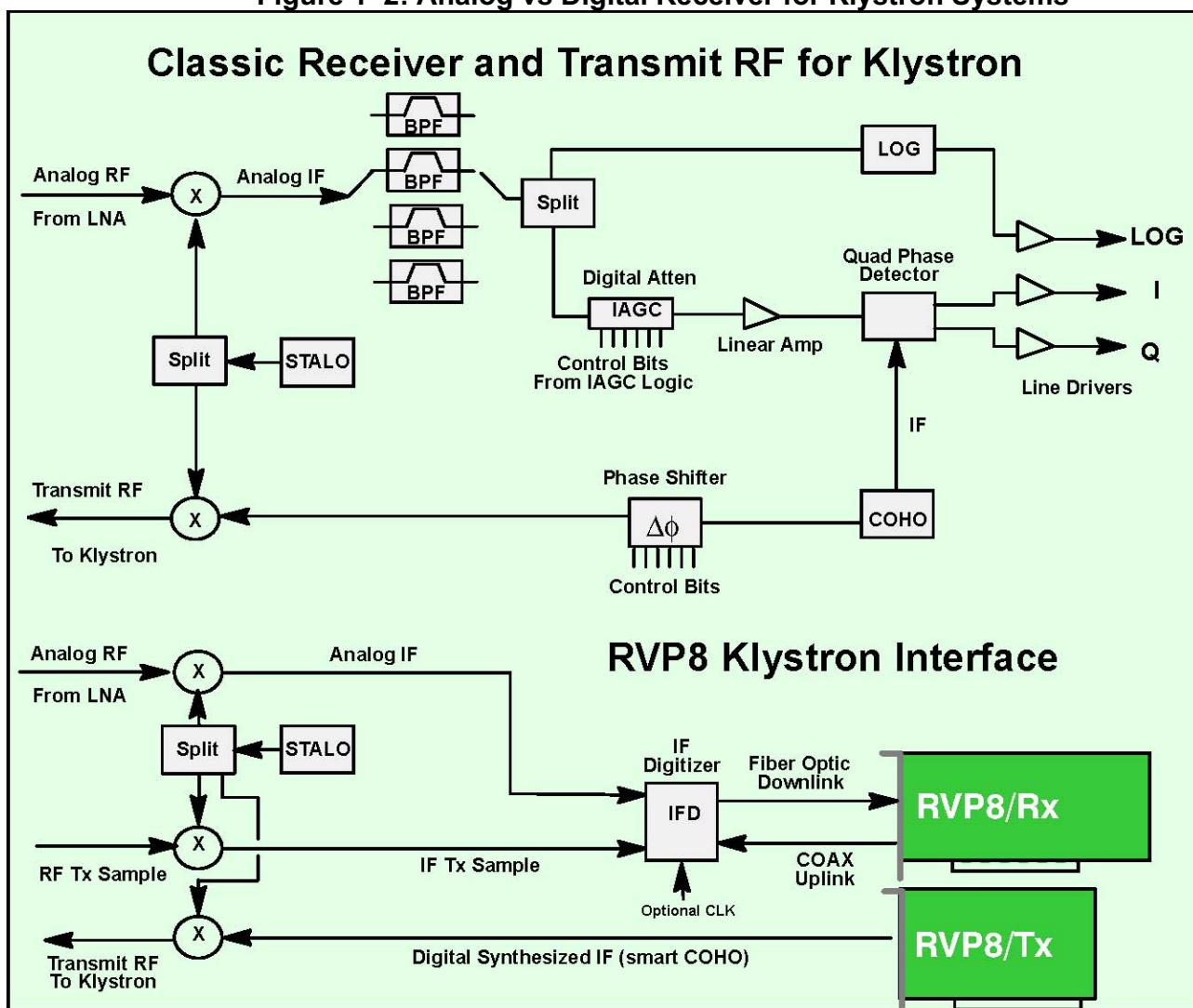

1.3 RVP8 IF Signal Processing

1.3.1 IFD Data Capture and Timing

The RVP8 design concept is to perform very little signal processing within the IFD digitizer module itself. This is to minimize the presence of digital components that might interfere with the clean capture of the IF signals.

The digitized IF and burst pulse samples are multiplexed onto the fiber channel link which provides the digital data to the RVP8/Main board at approximately 540-MBits/sec. The 14-bit samples are encoded for transmission over a fiber channel link. This optical link allows the IFD to be as far as 100 meters away from the RVP8/Main board and provides an added degree of noise immunity and isolation.

The uplink input from the RVP8/Main board provides the timing for multiplexing the burst pulse sample with the IF signal. In addition, it is used to set the AFC DAC or digital output level, and to perform self tests.

The sample clock oscillator in the IFD is selected to be very stable. The sample clock serves a similar function to the COHO on a traditional Klystron system, i.e., it is the master time keeper. Because of this the IFD sample clock is used to phase lock the entire RVP8, i.e., the Rx, Tx, IO-62 boards and the SoftPlane are all phase locked to the IFD sample clock. Designers have two choices for factory configuration of the IFD sample clock:

- A fixed crystal frequency selected to achieve a desired range resolution. The standard range resolution corresponds to 25 m increments.

- A very narrow band VCXO (50 ppm) selected to lock to an input reference signal from the radar, and provide a desired range resolution. SIGMET stocks VCXO's for 25 m range resolution increments for reference inputs of 10, 20, 30 and 60 MHz. Custom frequency VCXO's are available on request. Examples of external reference signal sources are an external COHO, external STALO reference or perhaps even a GPS clock).

1.3.2 Burst Pulse Analysis for Amplitude/Frequency/Phase

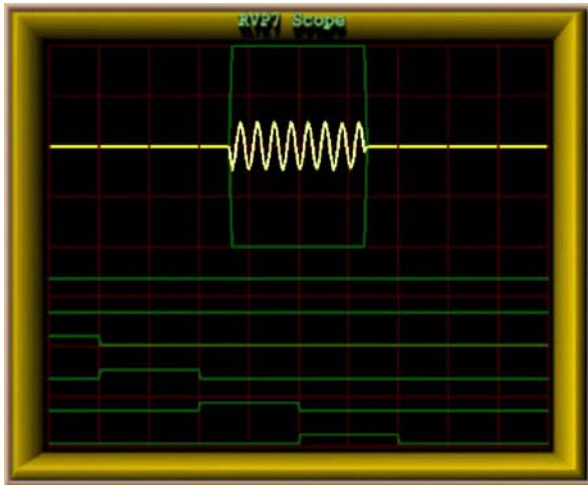

The burst pulse analysis provides the amplitude, frequency and phase of the transmitted pulse. The phase measurement is analogous to the COHO locking that is performed by a traditional magnetron radar. The difference is that the phase is known in the digital technique, so that range dealiasing using the phase modulation techniques is possible. Amplitude measurement (not performed by traditional radars) can provide enhanced performance by allowing the “I” and “Q” values to be corrected for variations in the both the average and the pulse-to-pulse transmitted power. In addition, a warning is issued if the burst pulse amplitude falls below a threshold value.

The burst pulse data stream is first analyzed by an adaptive algorithm to locate the burst pulse power envelope (e.g. 0.8 μ sec). The algorithm first does a coarse search for the burst pulse in the time/frequency domain (by scanning the AFC) and then does a fine search in both time and frequency, to assure that the burst is centered at “range 0” and is at the required IF value. The power-weighted phase of the burst pulse and the total burst pulse power is then computed. The power weighted average phase is used to make the digital phase correction. Phase jitter for magnetron systems with good quality modulator and STALO is better than 0.5 degrees RMS, as measured on actual nearby clutter targets. For Klystron systems, the phase locking is better than 0.1 degree RMS.

The burst pulse frequency is also analyzed to calculate the frequency error from the nominal IF frequency. For magnetron systems, the error is filtered with a selectable time constant which is typically set to several minutes to compensate for slow drift of the magnetron. The digital frequency error is sent via the uplink to the IFD in the receiver cabinet where a DAC converts it into an analog output to the magnetron STALO. Optionally, a DAFC unit can be Teed off the uplink cable to interface to Klystron systems do not require the AFC.

1.3.3 Rx Board and CPU IF to I/Q Processing

Figure 1–3: IF to I/Q Processing Steps

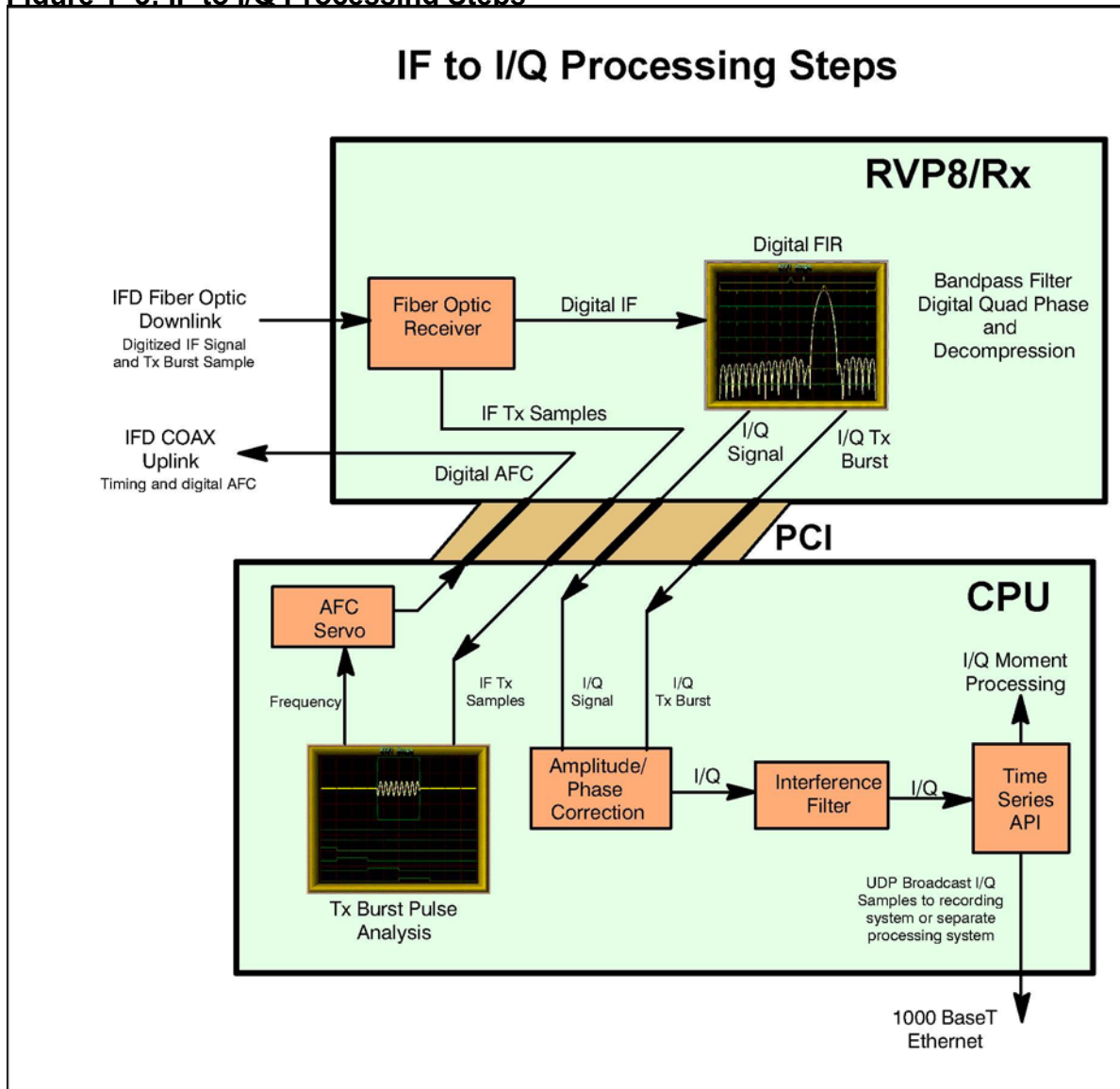

The RVP8/Rx board performs the initial processing of the IF digital data stream and outputs “I” and “Q” data values to the host computer via the PCI bus. In addition, the frequency, phase and amplitude of the burst pulse are measured. The functions performed by the processor are:

Reception of the digital serial fiber optic data stream.

Band pass filtering of the IF signal using configurable digital FIR filter matched to the pulsewidth.

Range gating and optional coherent averaging (essentially performed during the band pass filtering step).

Computation of “I” and “Q” quadrature values (also performed during the band pass filtering step).

Transmit burst sample frequency, phase and amplitude calculation

I and Q phase and amplitude correction based on transmit burst sample.

Interference rejection algorithm.

AFC frequency error calculation with output to IFD for digital or analog control of STALO (for magnetron systems).

The advantage of the digital approach is that the software algorithms for these functions can be easily changed. Configuration information (e.g., processor major mode, PRF, pulsewidth, gate spacing, etc.) is supplied from the host computer.

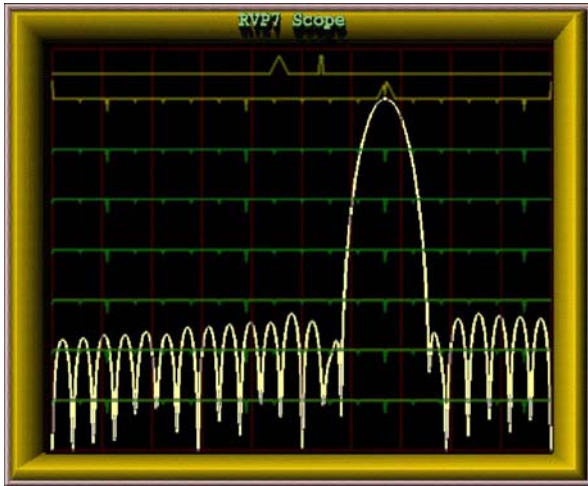

The digital matched filter that computes “I” and “Q” is designed in an interactive manner using a TTY and oscilloscope for graphical display. The filter’s passband width and impulse response length are chosen by the user, and the RVP8 constructs the filter coefficients using built-in design software. The frequency response of the filter can be

displayed and compared to the frequency response of the actual transmitted pulse. Microwave energy can come from a variety of transmitters such as ground-based, ship-based or airborne radars as well as communications links. These can cause substantial interference to a weather radar system. Interference rejection is provided as standard in the RVP8. Three different interference rejection algorithms are supported.

The RVP8/Rx board places the wide dynamic range “I” and “Q” samples directly on the PCI bus where they are sent to the processor section of the PC (e.g., dual Pentium processors on a single-board computer or motherboard). The I/Q values are then processed on the Pentium processors to extract the moment information (Z, V, W and optional polarization parameters).

The I and Q values can also be placed on a gigabit Ethernet line (1000 BaseT) which is provided directly on the processor board. This means that there is no second PCI bus “hit” required to send the data to a recording system or a completely separate processing system.

1.4 RVP8 Weather Signal Processing

The processing of weather signals by the RVP8 is based on the algorithms used in the previous generation RVP7 and RVP6. However, the performance of the RVP8 allows a different approach to some of the processing algorithms, especially the frequency domain spectrum processing. All of the algorithms start with the wide dynamic range I and Q samples that are obtained from the Rx card over the PCI bus.

The resulting intensity, radial velocity, spectrum width and polarization measurements are then sent to a separate host computer to serve as input for applications such as:

- Quantitative Rainfall Measurement
- Vertical Wind Profiling
- ZDR Hail Detection
- Tornado Detection and Microburst Detection
- Gust Front Detection
- Particle Identification
- Target Detection and Tracking

◆ General Weather Monitoring To obtain the basic moments, the RVP8 offers the option of several major processing modes:

- Pulse Pair Mode Time Domain Processing
- DFT/FFT Mode Frequency Domain Processing
- Random Phase Mode for 2nd trip echo filtering
- Polarization Mode Processing

Note that the RVP8 is the first commercial processor to perform discrete Fourier transforms (DFT) as well as fast Fourier transforms (FFT). FFT is more computationally efficient than DFT, but the sample size is limited to be a power of two (16, 32, 64, ...) This is too restrictive on the scan strategy for a modern Doppler radar since this means, for example, that a one degree azimuth radial must be constructed from say exactly 64 input I/Q values. The RVP8 has the processing power such that when the sample size is not a power of 2, a DFT is performed instead of an FFT

These modes share some common features that are described first, followed by descriptions of the unique features of each mode.

1.4.1 General Processing features

Figure 1–4 shows a block diagram of the processing steps. These are discussed below.

Autocorrelations

The autocorrelations R0, R1 and R2 are produced by all three processing modes. However, the way that they are produced is different for the three modes, particularly with regard to the filtering that is performed.

Pulse Pair Mode — Filtering for clutter is performed in the time domain. Autocorrelations are computed in the time domain.

DFT/FFT Mode — Filtering for clutter is performed in the frequency domain using both fixed width filters and the Gaussian Model Adaptive Processing (GMAP) technique. Autocorrelations are computed from the inverse transform.

Random Phase — Filtering for clutter and second trip echo is performed in the frequency domain by adaptive algorithms. Autocorrelations are computed from the inverse transform.

Figure 1–4: I/Q Processing for Weather Moment Extraction

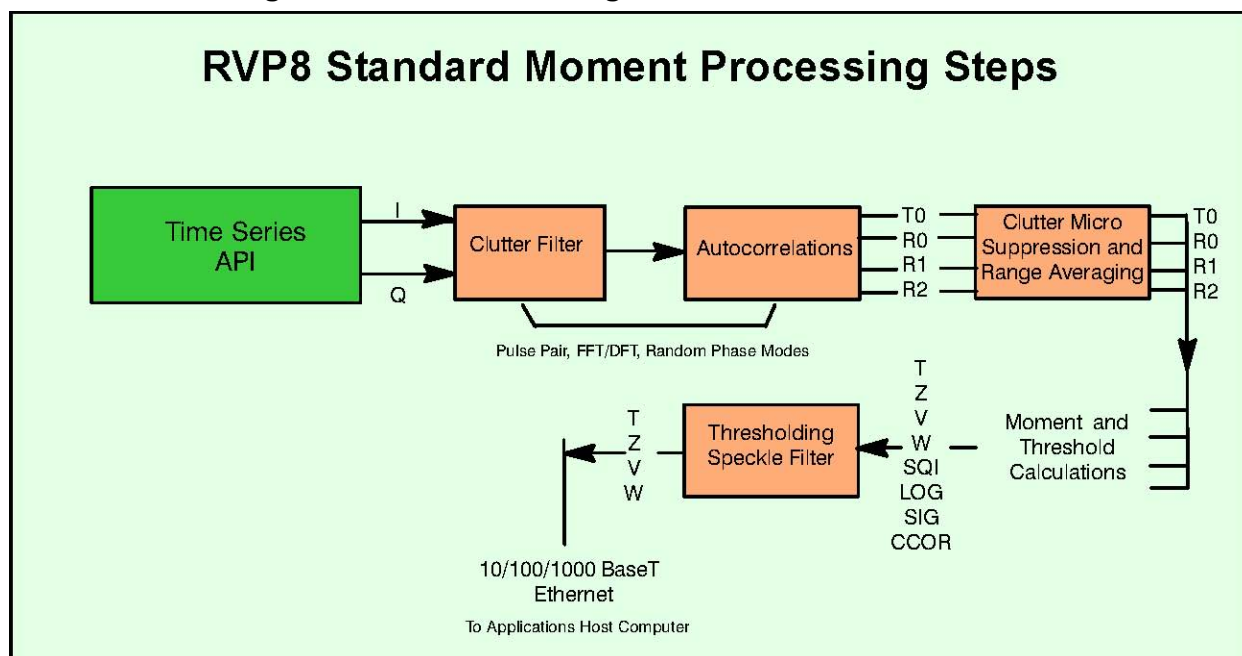

The use of the R2 lag provides improved estimation of signal-to-noise ratio and spectrum width. **Processors that do not use R2 cannot effectively measure the SNR and spectrum width.**

Time (azimuth) Averaging

The autocorrelations are based on input “I” and “Q” values over a selectable number of pulses between 8, 9, 10, ...,256. Any integer number of pulses in this interval may be used including DFT/FFT and random phase modes.

Selectable angle synchronization using the input AZ and EL tag lines assures that all possible pulses are used during averaging for each, say, 1 degree interval. This minimizes the number of “wasted” pulses for maximum sensitivity. Azimuth angle synchronization also assures the accurate vertical alignment of radial data from different elevation angles in a volume scan (see below).

TAG Angle Samples of Azimuth and Elevation

During data acquisition and processing it is usually necessary to associate each output ray with an antenna position. To make this task simpler the RVP8 samples 32 digital input “TAG” lines, once at the beginning and once at the end of each data acquisition period. These samples are output in a four-word header of each processed ray. When connected to antenna azimuth and elevation, the TAG samples provide starting and ending angles for the ray, from which the midpoint could easily be deduced. Since the bits are merely passed on to the user, any angle coding scheme may be used. The processor also supports an angle synchronization mode, in which data rays are automatically aligned with a user-defined table of positions. For that application, angles may be input either in binary or BCD.

Range Averaging and Clutter Microsuppression

To improve the accuracy of the reflectivity measurements, the RVP8 can perform range averaging. When this is done, autocorrelations from consecutive range bins are averaged, and the result is treated as if it were a single bin. This type of averaging is useful to lower the number of range bins that the host computer must process.

Range averaging of the autocorrelations may be performed over 2, 3, 4, ..., 16 bins. Prior to range averaging, any bins that exceed the selectable clutter-to-signal threshold are discarded. This prevents isolated strong clutter targets from corrupting the range average, which improves the sub-clutter visibility.

Moment Extraction

The autocorrelations serve as the basis for the Doppler moment calculations,

Mean velocity – from $\text{Arg} [R1]$

Spectrum width – from $|R1|$ and $|R2|$ assuming Gaussian spectrum

dBZ – from $R0$ with correction for ground clutter, system noise and gaseous attenuation.

Uses calibration information supplied by host computer.

dBZ – identical to dBZ except without ground clutter.

These are the standard parameters that are output to the host computer on the high-speed Ethernet interface.

Thresholding

The RVP8 calculates several parameters that are used to threshold (discard) bins with weak or corrupted signals. The thresholding parameters are:

- Signal quality index ($SQI=|R1|/R0$)
- LOG (or incoherent) signal-to-noise ratio (LOG)
- SIG (coherent) signal-to-noise ratio
- CCOR clutter correction

These parameters are computed for each range bin and can be applied in AND/OR logical expressions independently for dBZ, V and W.

Speckle Filter

The speckle filter can be selected to remove isolated single bins of either velocity/width or intensity. This feature eliminates single pixel speckles which allows the thresholds to be reduced for greater sensitivity with fewer false alarms (speckles). Both a 1D (single azimuth ray) and 2D (3 azimuth rays by 3 range bins) are supported.

Velocity Unfolding

A special feature of the RVP8 processor is its ability to “unfold” mean velocity measurements based on a dual PRF algorithm. In this technique two different radar PRF’s are used for alternate N-pulse processing intervals. The internal trigger generator automatically produces the correct dual-PRF trigger, but an external trigger can also be applied. In the later case, the ENDRAY_ output line provides the indication of when to switch rates. The RVP8 measures the PRF to determine which rate (high or low) was present on a given processing interval, and then unfolds based on either a 2:3, 3:4 or 4:5 frequency ratio. Table 1–1 gives typical unambiguous velocity intervals for a variety of radar wavelengths and PRF’s.

Table 1–1: Examples of Dual PRF Velocity Unfolding

Unambiguous Velocity (m/s) for Various Radar Wavelengths

| PRF1 | PRF2 | Unambiguous Range (km) | 3 cm | 5 cm | 10 cm | |
|------|------|------------------------|-------|-------|-------|------------|
| 500 | * | 300 | 3.75 | 6.25 | 12.50 | No |
| 1000 | * | 150 | 7.50 | 12.50 | 25.00 | U f |
| 2000 | * | 75 | 15.00 | 25.00 | 50.00 | ldiUnfoldi |
| | | | | | | ng |
| 500 | 333 | 300 | 7.50 | 12.50 | 25.00 | Two |
| 1000 | 667 | 150 | 15.00 | 25.00 | 50.00 | TiTimes |

Unambiguous PRF1 PRF2 Range (km) 3 cm 5 cm 10 cm

| | | | | | | |
|------|------|-----|-------|--------|--------|-----------------------|
| 500 | 375 | 300 | 11.25 | 18.75 | 37.50 | Three Times Unfolding |
| 1000 | 750 | 150 | 22.50 | 37.50 | 75.00 | |
| 2000 | 1500 | 75 | 45.00 | 75.00 | 150.00 | |
| 500 | 400 | 300 | 15.00 | 25.00 | 50.00 | Four Times Unfolding |
| 1000 | 800 | 150 | 30.00 | 15.00 | 100.00 | |
| 2000 | 1600 | 75 | 60.00 | 100.00 | 200.00 | |

1.4.2 RVP8 Pulse Pair Time Domain Processing

Pulse pair processing is done by direct calculation of the autocorrelation. Prior to pulse pair processing, the input “I” and “Q” values are filtered for clutter using a time domain notch filter. Filters of various selectable widths are available for either 40 or 50 dB stop band attenuation. The filtered I/Q values are processed to obtain the autocorrelation lags R0, R1 and R2. The unfiltered power is also calculated (T0). The autocorrelations are then sent to the range averaging and moment extraction steps.

1.4.3 RVP8 DFT/FFT Processing

The DFT/FFT mode allows clutter cancelation to be performed in the frequency domain. DFT is used in general, with FFT’s used if the requested sample size is a power of 2.

Three standard windows are supported to provide the best match of window width to the spectrum dynamic range:

- Rectangular
- Hamming
- Blackman
- Exact Blackman
- Von Han

After the FFT step, clutter cancelation is done using a selectable fixed width filter that interpolates across the noise or any overlapped weather or an adaptive filter which automatically determines the optimal width. This technique preserves overlapped weather as compared to time domain notch filters which will always attenuate overlapped weather to some extent, depending on the spectrum width. After clutter cancelation, R0, R1 and R2 are computed by inverse transform and these are used for moment estimation.

1.4.4 Random Phase Processing for 2nd Trip Echo

Second trip echoes can be a serious problem for applications that require operation at a high PRF. Second trip echoes can appear separately or can be overlaid on first trip echoes (second trip obscuration). The random phase technique separates the first and second trip echoes so that:

In nearly all cases, the 2nd trip echo can be removed from the first trip even in the case of overlapped 1st and 2nd trip echoes. The benefit is a clean first trip display.

The 2nd trip echoes can be recovered and placed at their proper range at 1st trip/2nd trip signal ratios of up to 40 dB difference for overlapped echoes. Because of the wide dynamic range of weather echoes, this power limit will sometimes be exceeded.

The technique requires that the phase of each pulse be random. Digital phase correction is then applied in the processor for the first and second trips. The critical step is the adaptive filter which removes the echo of the other trip to increase the SNR. Magnetrons have a naturally random phase. For Klystron radars, a digitally controlled precision IF phase shifter is required. The RVP8 provides an 8-bit RS422 output for the phase shifter.

For more information on the technique refer to Joe, et. al., 1995.

1.4.5 Polarization Mode Processing

Polarization processing uses a time domain autocorrelation approach to calculate the various parameters of the polarization co-variance matrix, i.e., ZDR, LDR, PHIDP, RHOHV, PHIDP (KDP), etc. In addition, the standard moments T, V, Z, W are also calculated. Which parameters are available and which algorithms are used to calculate them depends on the type of polarization radar, e.g., single channel switching, simultaneous transmit and receive (STAR), dual channel switching. SIGMET, Inc. is licensed by US National Severe Storms Laboratory (NSSL) to use the STAR hardware and processing techniques and algorithms.

Polarization measurements require special calibration of the ZDR and LDR offsets. The use of a clutter filter for the polarization variables can sometimes bias the derived parameters. Because of this, the user decides whether or not to use filtered or unfiltered time series.

1.4.6 Output Data

The RVP8 output data for standard moment calculations consist of mean radial velocity (V), Spectrum Width (W), Corrected Reflectivity(Z or dBZ) and Uncorrected Reflectivity (T or dBZ). Other data outputs include I/Q time series, DFT/FFT power spectrum points and polarization parameters. The output can be made in either 8 or 16-bit format. 8-bit format is preferred over 16-bit format for most applications since the accuracy is more than adequate for an operational radar system, and the data communications are reduced by 50%. 16-bit formats are sometimes used by research customers for data archive purposes. Note that time series and DFT are always 16-bit formats. All data formats are documented in Chapter 6 of this manual.

A standard output is the I/Q time series on gigabit network (1000 BaseT). These are sent via UDP broadcast to an I/Q archiving system or even a completely independent parallel processing system.

1.5 RVP8 Control and Maintenance Features

1.5.1 Radar Control Functions

The RVP8 also performs several important radar control functions:

- Trigger generation- up to 6 programmable triggers.
- Pulsewidth control (four states controlled by four bits).
- Angle/data synchronization- to collect data at precise azimuth intervals (e.g., every 0.5, 1, 1.5 degrees) based on the AZ/EL angle inputs.
- Phase shifter- to control the phase on legacy Klystron systems. New or upgrade Klystron or TWT systems can use the RVP8/Tx card to provide very accurate phase shifting.
- ZDR switch control- for horizontal/vertical or other polarization switching scheme.
- AFC output (digital or analog) based on the burst pulse analysis for magnetron systems.

Pulsewidth and trigger control are both built into the RVP8. Four TTL output lines can be programmed to drive external relays that control the transmitter pulsewidth. The internal trigger generator drives six separate lines, each of which can be programmed to produce a desired waveform. The trigger generator is unique in that the waveforms are stored in RAM and can be modified interactively by user software. Thus, precisely delayed and jitter-free strobes and gates can easily be produced. For each pulsewidth there is a corresponding maximum trigger rate that can be generated. Note, however, that the RVP8 can also operate from an external user-supplied trigger. In either case, the processor measures the trigger period between pulses so that user software can monitor it as needed.

The RVP8 also supports trigger blanking during which one or more (selectable) of the transmit triggers can be inhibited. Trigger blanking is used to avoid interference with other electronic equipment and to protect nearby personnel from radiation hazard. There are two techniques for this:

- 2D AZ/EL sector blanking areas can be defined in the RVP8 itself.
- An external trigger blanking signal (switch closure to ground, TTL or RS422) can be supplied, for example from a proximity switch that triggers when the antenna goes below a safe elevation angle or connected to the radome access hatch.

1.5.2 Power-Up Setup Configuration

The RVP8 stores on disk an extensive set of configuration information. The purpose of these data is to define the exact configuration of the RVP8 upon startup. The setup information can be accessed and modified using either a local keyboard and monitor, or over the network. For multiple radar networks, the configuration management can be centrally administered by copying tested “master” configuration files to the various network radars. It is not necessary to go to the radar to change ROM’s as was the case for previous generation processors.

1.5.3 Built-In Diagnostics

On power-up, the RVP8 performs a sequence of internal self-tests. The test sequence requires about four seconds to perform, and tests approximately 95% of the internal digital circuitry. Errors are isolated to specific sections of the board as much as possible. If any check fails, the user can be certain that some component is not functioning correctly. However, there is a very small chance that even a defective board may pass all the tests; the failure may be in one of the few areas that can not be checked.

The RVP8 displays the test results on the LED front panel (for a standard SIGMET chassis). In this way, there is immediate visual confirmation of the diagnostic tests, even if the host computer has not yet been connected. The local keyboard and monitor or a networked workstation can be used to see the test results in the TTY menus or even invoke a power-up reset and test.

1.6 Support Utilities and Available Application Software

The RVP8 system includes a complete set of tools for the calibration, alignment and configuration of the RVP8. These includes the following utilities:

ascope-a comprehensive utility for manual signal processor control and data display of moments, times series and Doppler spectra. ascope includes a realistic signal simulator capable of producing both first and second trip targets. Recording/playback of time series and moments is included as well.

dsp-an ASCII text-based program to access and control the signal processor, including providing access to the local setup menus.

speed- a performance measuring utility.

DspExport-exports the RVP8 to another workstation over the network. This allows utilities on a remote network to run locally, as opposed to exporting the utility display window over the network.

setup- interactive GUI for creating/editing the RVP8 configuration files.

zauto- calibration utility for use with a test signal generator.

These tools can be run locally on the RVP8 itself or over the network from a central maintenance facility. The DspExport utility improves the performance of the utilities for network applications by letting them be run on the workstation that is remote from the RVP8. Note that standard X–Window export is of course supported but requires more bandwidth.

In addition, complete radar application software can be purchased from SIGMET:

IRIS/Radar on a separate PC, interfaces to the RVP8 by 100 BaseT Ethernet. IRIS/Radar controls both the RVP8 and the SIGMET RCP8 radar/antenna control processor. The package provides complete local and remote control/monitoring, data processing and communication for a radar system.

IRIS/Analysis (and options) runs on a separate PC, often at a central site. One IRIS/Analysis can support up to 20 radar systems. This functions as a radar product generator (RPG) to provide outputs such as CAPPI, rain accumulations, echo tops, automatic warning and tracking, etc. Optional software packages are provided for special applications: wind shear and microburst detection, hydrometeorology with raingage calibration and subcatchments, composite, dual Doppler and 3D Display.

IRIS/Web provides IRIS displays to network users on standard PC's (Windows or Linux) running Netscape or Internet Explorer.

IRIS/Display can display products sent to it and, with password authorization, can serve as a remote control and monitoring site for networked radar systems. Features such as looping, cross–section, track, local warning, annotation, etc. are all provided by IRIS/Display. Note that both IRIS/Analysis and IRIS/Radar have all of the capabilities of IRIS/Display in addition to their own functions. This means that any IRIS system can display products.

1.7 System Network Architecture

The RVP8 provides considerable flexibility for network operation. This allows remote control and monitoring of the system from virtually anywhere on the network, subject to the user’s particular security restrictions.

Unlike the previous generation RVP7, which used a SCSI interface, the RVP8 uses a network interface exclusively. The “dsp lib” runs locally on the RVP8 and a utility, called DspExport, exports the library over the network using a TCP/IP socket. Typically this is exported to a local host radar control workstation (RCW) on the network. Perhaps this workstation is running the SIGMET IRIS software. At least 10BaseT connection is recommended for this connection.

Figure 1–5: Network Architecture for Socket Interface with DspExport

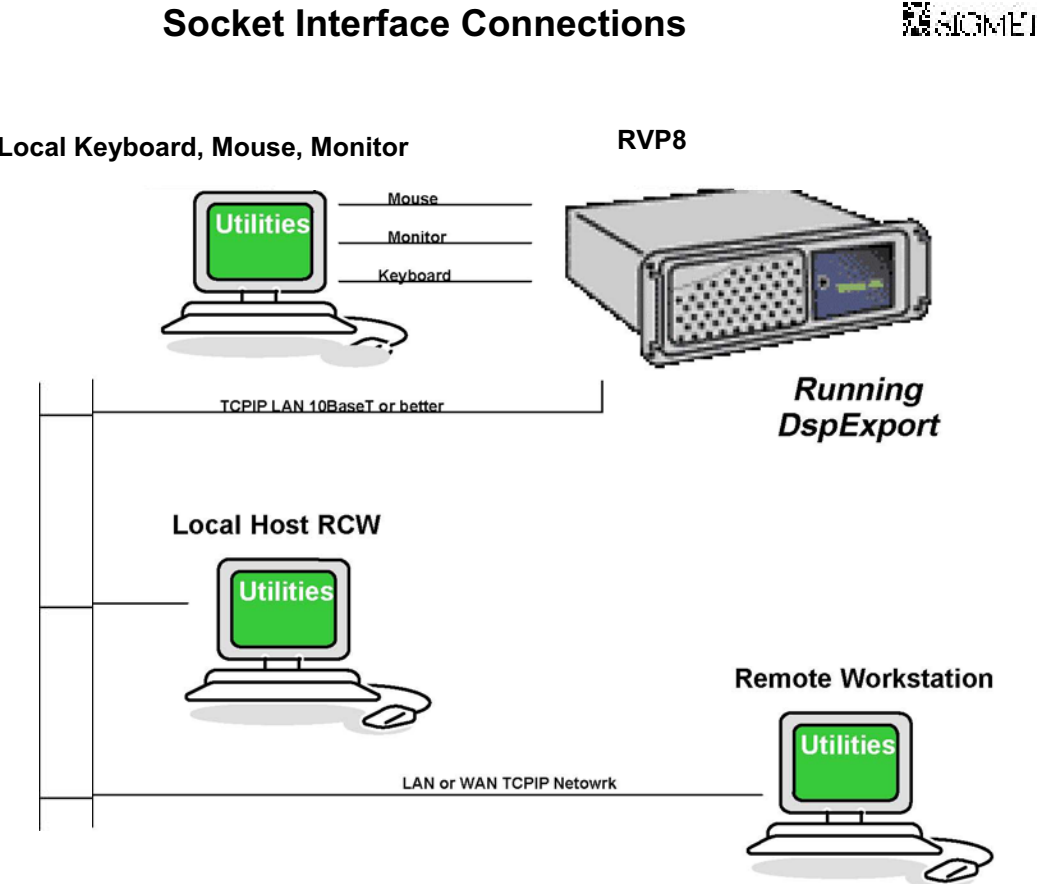

A remote workstation on the network can also use the DspExport technique to communicate for configuration, monitoring and diagnostic testing.

1.8 Open Architecture and Published API

SIGMET recognizes that certain users may require the ability to write their own signal processing algorithms which will run on the RVP8. To accommodate this, the RVP8 software is organized to allow separately compiled plug-in modules to be statically linked into the running code. The application program interface (API) allows user code to be inserted at the following stages of processing:

Tx/Rx waveform synthesis and matched filter generation— The API allows the transmit waveforms to be defined from pulse to pulse, along with the corresponding FIR coefficients that will extract (I,Q) from that Tx waveform. This allows users to experiment with arbitrary waveforms for pulse compression and frequency agility.

Time series and spectra processing from (I,Q)- The API allows you to modify the default time series and spectra data, e.g., to perform averaging or windowing in a different way.

Parameter generation from (I,Q)- This is probably where the greatest activity will occur for user-supplied code. The API allows you to redefine how the standard parameters (dBZ, Velocity, Width, PHIDP, etc.) are computed from the incoming (I,Q) time series. You may also create brand new parameter types that are not included in the basic RVP8 data set.

Note that the standard SIGMET algorithms are not made public in this model. Rather, the interface hooks and development tools are provided so that users can add their own software extensions to the RVP8 framework. Many of the library routines that are fundamental to the RVP8 are also documented and can be called by user code; but the source to these routines is not generally released. Development tools which are not under public license must be purchased separately by the customer.

While most customers will use the signal processing software supplied by SIGMET, the new open software architecture approach employed by the RVP8 will be very useful to those research customers who want to try innovative new approaches to signal processing, or to those OEM manufacturers who are interested in having their own “custom” stamp on the product.

1.9 RVP8 Technical Specifications

1.9.1 IFD Digitizer Module, Rev E or later

Input Signals ♦ IF Received Signal: 50♦, + 6.5 dBm full-scale, +20dBm

absolute max ♦ IF Burst or COHO: 50♦, +6.5 dBm full-scale, +20dBm absolute
max

♦ Optional Reference Clock: 2–60 MHz –10 to 0 dBm

IF Ranges:

♦ 12—34 MHz, 38—70 MHz

Linear Dynamic Range

♦ 85 to >100dB depending on pulsewidth/bandwidth filter

A/D Conversion

Resolution 14 bit with jitter <2.5 picosec

Sampling rate 67 to 79 MHz (selectable, standard is 71.9364 MHz)

AFC Output

Analog –10 to +10V

Optional Digital AFC (DAFC) with up to 24 programmable output bits.

Automatic 2-D (time/frequency) burst pulse search and fine tracking algorithms.

IFD Link

♦ Uses shielded CAT 5E cable, non standard signals, requires RVP8/Rx card, rev C or later.

Cable length to RVP8/Rx

♦ 2—25 meters, with automatic calibration of round trip time and range correction.

1.9.2 RVP8/Rx PCI Card, Rev C or later

Pulse Repetition Frequency

- ◆ 50 Hz to 20 KHz +0.1%, continuously selectable.

IF Band Pass Filter

- ◆ Programmable Digital FIR with software selectable bandwidth. Built-in filter design software with graphical user interface.

Impulse Response

- ◆ Up to 3024 FIR filter taps, corresponding to 75 ◆sec impulse response length for 72 MHz IF samples at 125 meter range resolution. These very long filters are intended for use with pulse compression.

Range Resolution

- ◆ Minimum bin spacing of 25 meters selectable in $N \times 8.33$ meter steps. Bins can be positioned in a configurable range mask with resolution of $N \times$ the fundamental bin spacing, or arbitrarily to an accuracy of ± 2.2 meters.

Maximum Range

- ◆ Up to 1024 km

Number of Range Bins

- ◆ Full unambiguous range at minimum resolution or 3096 range bins (whichever is less). The RVP8 processor may only be fast enough to process an average of 50 meter bins.

Electrical Interfaces

- ◆ CAT 5E cable from the IFD, rev E or later.
- ◆ BNC #1 for trigger output (12V, 75 ◆), or pretrigger input. BNC #2 for trigger output (12V, 75 ◆).
- ◆ 9-pin "D" connector supporting four RS-422 differential signals for miscellaneous input and output with SoftPlane ◆ support. Each line pair can operate as a transmitter or as a receiver depending on what's needed. Possible uses are: alternate reference clock input, gating input for CW modes, additional trigger outputs, external phase shift requests, etc.

Data Output via PCI Bus

16-bit floating I and Q values
14-bit raw IF samples

1.9.3 RVP8/Tx PCI Card

Analog Waveform Applications

Digitally synthesized IF transmit waveform for pulse compression, frequency agility, and phase modulation applications.

Master clock or COHO signal to the radar; can be phase locked or free running, arbitrary frequency.

Analog Output Waveform Characteristics

◆ Two independent, digitally synthesized, analog output waveforms (BNC). These two outputs are electrically identical and logically independent IF waveform synthesizers that can produce phase modulated CW signals, finite duration pulses, compressed pulses, etc.
◆ Can drive up to +12dBm into

◆◆. 14-bit interpolating TxDAC provides 71dB Signal-to-Noise

Ratio. IF center frequency selectable from 8 to 32.4 MHz, and from 48.6 to 75MHz.

◆ Signal bandwidth as large as 15MHz for wideband/multiband Tx applications. Band width is adjustable in software.

◆ Continuous or pulse modulated output with band width limiting on pulse modulation output.

◆ Precise phase shifting with transient band width

limiting. Total harmonic distortion less than –

74dB. Waveform pre-emphasis compensates for both static and dynamic Tx nonlinearities.

Other I/O signals

◆ Clock In/Out 50◆ SMA connector. This can receive a CW reference frequency to which the RVP8/Tx can lock to a P/Q frequency multiple (much like the RVP8/IFD can lock to an external reference). This connector can also supply the TxData Clock, optionally divided by some N between 1 and 16, in order to supply external circuitry with +10dBm clock reference at 50◆.

◆ 9-pin “D” connector supporting four RS-422 differential signals for miscellaneous input and output with SoftPlane◆ support. Each line pair can operate as a transmitter or as a receiver depending on what’s needed. Possible uses are: alternate reference clock input, gating input for CW modes, additional trigger outputs, external phase shift requests, etc.

1.9.4 SIGMET I/O-62 PCI Card

Short format PCI card with 62-position “D” connector. Multiple cards may be installed. Includes D/A, A/D, discrete inputs and outputs (TTL, wide range, RS422, etc.) See summary table below.

I/O pin assignment mapping by **softplane.conf** file.

Standard or custom remote backpanels available.

- ◆ ESD protection using Tranzorb◆ silicon avalanche diode surge suppression and high-voltage tolerant components.

| SIGMET I/O-62 Summary of Electrical Interfaces | |
|---|---|
| Qty | Description |
| 40 | Lines configurable in groups of 8 to be either inputs or outputs. The electrical specifications are software defined within each group as follows: ◆ Single-ended TTL input or output with software-configured pull-up or pull-down resistors for inputs. ◆ Wide range inputs (◆ 27VDC, threshold +2.5VDC), often used for “lamp voltage” status inputs. ◆ RS-422/485 @ 10 MBit/sec (requires two lines each). RS-422 receivers can be configured in software to have 100◆ termination between each pair. |
| 8 | A/D convertors configurable as 0, 4, or 8 convertors, ◆ 2V, 12 bits @ 10 MHz, These lines are shared with some of the 40 I/O lines listed above. |
| 2 | D/A convertors, ◆ 10V 1 MHz update rate, output can drive a 75◆ load. |
| 2 | SPDT relays on the board. These are often used for switching high power relays. Contacts are diode protected. |
| 2 | RS-232C full duplex lines (Tx and Rx) |
| 4 | 12V 75◆ trigger drivers . |
| 2 | Power/Ground pairs of 12V power (filtered, fused) for external equipment or remote backpanel use (up to 24 W total). Polyfuse technology acts like a circuit breaker with auto reset in the event of an overload. |
| 8 | Ground wires for signal grounds from the remote back panel. |

1.9.5 I/O-62 Standard Connector Panel

Mounts on front or rear of standard 19" EIA rack

Connects to I/O-62 via 1:1 62-pin 1.8-m cable (provided).

Provides standard inputs and outputs required by most weather radars such as triggers, polarization control, pulse width control and antenna angles.

Az and El synchro and reference inputs (nominal 100V 60 Hz)

3 internal relays and 4 12V relay control signals for switching external devices.

Programmable scope test points with source waveforms selectable in software.

Diagnostic power supply and self test LED's for troubleshooting.

| RVP8 Connector Panel Summary | | | |
|-------------------------------------|--------------|-------------|--|
| J-ID | Label | Type | Description |
| J1 | AZ INPUT | DBF25 | Up to 16-bits of parallel TTL binary or BCD angle |
| J2 | AZ OUTPUT | DBF25 | Up to 16-bits of parallel TTL binary or BCD angle |
| J3 | PHASE OUT | DBF25 | Up to 8-bits of parallel TTL or RS422. Angles are configurable. |
| J4 | EL INPUT | DBF25 | Up to 16-bits of parallel TTL binary or BCD angle |
| J5 | EL OUTPUT | DBF25 | Up to 16-bits of parallel TTL binary or BCD angle |
| J6 | RELAY | DBF25 | 3 internal relays, contact rating 0.5 A continuous. The switching load is 0.25 A and 100V, with the additional constraint that the total power not exceed 4VA. 4, 12V relay control signals, up to 200mA. (Note that external relays should be equipped with proper diode protection to shunt the back EMF). |
| J7 | SPARE | DBF25 | 20 additional TTL I/O lines each configurable to be input or output. |
| J8 | SPARE | DBF25 | 10 differential analog inputs, up to $\pm 20V$ max multiplexed into A/D convertor sampling each at >1000 Hz. |
| J9 | MISC I/O | DBF25 | 7 additional RS422 lines and 2 each dedicated (non-multiplexed) A/D inputs ($\pm 580V$ with pot adjust) and D/A outputs ($\pm 10V$). |
| J10 | SERIAL | DBF9 | RS232C |
| J11 | SERIAL | DBF9 | RS232C |
| J12 | S-D | Modular | 3 x 4 matrix connector for AZ and EL synchro and reference inputs |
| J13 | TP-1 | BNC | Programmable scope test point. 75 Ohms |
| J14 | TP-2 | BNC | Programmable scope test point. 75 Ohms |
| J15 | TRIG-1 | BNC | 12V trigger into 75 Ohms |
| J16 | TRIG-2 | BNC | 12V trigger into 75 Ohms |
| J17 | TRIG-3 | BNC | 12V trigger into 75 Ohms |
| J18 | TRIG-4 | BNC | 12V trigger into 75 Ohms |

1.9.6 RVP8 Processing Algorithms

Input from Rx Board

- 16-bit I/Q samples
- Optional dual-channel I/Q samples (e.g., for polarization systems or dual frequency systems)

IQ Signal Correction Options

- Amplitude jitter correction based on running average of transmit power from burst pulse.
- Interference correction for single pulse interference
- Saturation correction (3 to 5 dB)

Primary Processing Modes

- Poly-Pulse Pair (PPP) ♦ DFT
- Random or Phase Coded 2nd trip echo filtering/recovery
- Optional Polarization with full co-variance matrix (ZDR, PHIDP, LDR, RHOHV, etc.)
- Optional Pulse Compression

Processing Options

- FIR Clutter filters (40 and 50 dB) in pulse pair mode.
- Adaptive width clutter filters in DFT and phase coded 2nd trip mode.
- Velocity De-Aliasing: Dual PRF Velocity unfolding at 3:2, 4:3 and 5:4 PRF ratios or Dual PRT Velocity processing for selectable inter-pulse intervals.
- Range De-aliasing: Phase coding method (random phase for magnetron) Frequency coding method (not available for magnetron)
- Scan angle synchronization for data acquisition.
- Pulse integration up to 1024
- Corrections for gaseous attenuation and $1/R^2$.
- Up to 4 pulse widths

Data Outputs

- dBZ Calibrated equivalent radar reflectivity, 8 or 16 bits
- V Mean radial velocity, 8 or 16 bits

W Spectrum width, 8 or 16 bits

I/Q Time series, 16 bits each per sample

DFT Doppler Spectrum output option in DFT mode, 16 bits per component

Optional: ZDR, PHIDP, RHOHV, LDR, RHO, 8 or 16 bits

Data Quality Thresholds

Signal-to-noise ratio (SNR) Used to reject bins having weak signals. Typically applied to dBZ.

Signal quality index (SQI) Used to reject bins having incoherent signals. Typically applied to mean velocity and width.

Clutter-to-signal ratio (CSR) Used to reject range bins having very strong clutter. Typically applied to mean velocity, width and dBZ.

Speckle Filter Filter removes single-bin targets such as aircraft or noise Fills isolated missing pixels as well.

1.9.7 RVP8 Input/Output Summary

Ethernet Input/Output from Host Computer

- ◆ Data output of calibrated dBZ, V and W during normal operation. Full I/Q timeseries recording with a separate **tsarchive** utility, or through a customer's application using a public API. Signal processor configuration and verification read-back is performed via the Ethernet interface.

RS-232C Serial Data I/O

- ◆ For real time display/monitoring or data remoting.

AZ/EL Angle Input Options

Serial AZ/EL angle tag input using standard SIGMET RCP format.
16-bit each parallel TTL binary angles via the I/O-62 card.
Synchro angle inputs via the I/O-62 card.
SIGMET network antenna packet protocol.

Trigger Output

- ◆ Up to 10 total triggers available on various connector pins. Triggers are programmable with respect to trigger start, trigger width and sense (normal or inverted).

Optional Polarization Control

- ◆ RS-422 differential control for polarization switch.

1.9.8 Physical and Environmental Characteristics

Packaging

- ◆ Motherboard Configuration 4U rack mount with 6 PCI slots
- ◆ Custom PC configurations available or packaged by customer.
- ◆ Dimensions of standard 4U chassis
43.2 wide x 43.2 long x 17.8 cm high 17
wide x 17 long x 7.00 inch high
- ◆ Dimensions IF Digitizer
2.5 wide x 10.9 long x 23.6 cm high 1
wide x 4.3 long x 9.3 inch high
- ◆ Redundant Power Supplies. Three hot-swap modules with audio failure alarm.

Input Power

IFD 100–240 VAC 47–63 Hz auto-ranging
Main Chassis 60/50 Hz 115/230 VAC Manual Switches

Power Consumption

RVP8/Main Processor 180 Watts with Rx and Motherboard
RVP8/IFD IF Digitizer 12 Watts

Environmental

Temperature 0C (32F) to 50C (122F)
Humidity 0 to 95% non-condensing

Reliability

- ◆ MTBF>50,000 hours (based on actual RVP7 field data).