

Place the 2 Philips head screws supplied into the centre two screw holes as shown remembering to hold the screws in place.

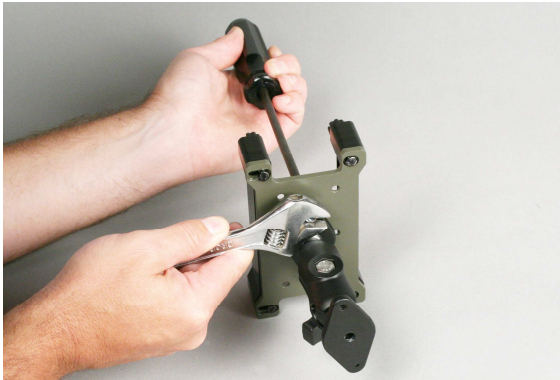

While holding one of the screws in with an appropriate Philips head screw driver use a shifter to tighten the supplied nut. Repeat with second screw.

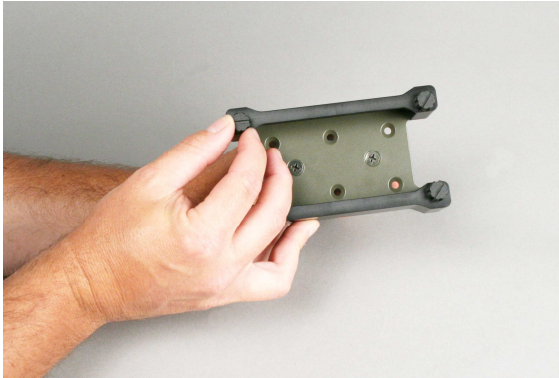

Now loosen 2 of the black thumbscrews located on the top of the display vehicle adapter.

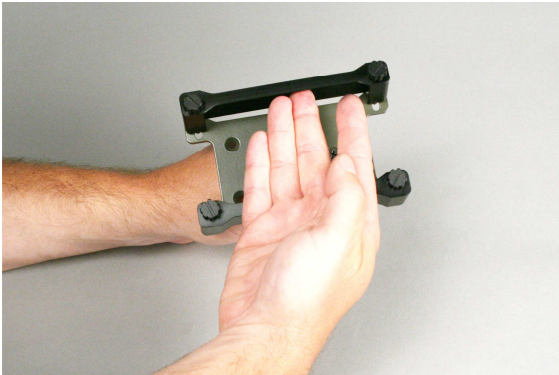

Once these have been loosened push the loosened cradle slide up as high as possible.



To insert the LCD unit into the adapter, place the bottom of the LCD unit into the display vehicle mount bracket.



Next push the top of the display into the bracket, push the cradle slide down and tighten the black thumb screws.



The removable display vehicle mounting bracket is now ready to be mounted at the required position.

PRC-2090 Docking Station – Rear Panel

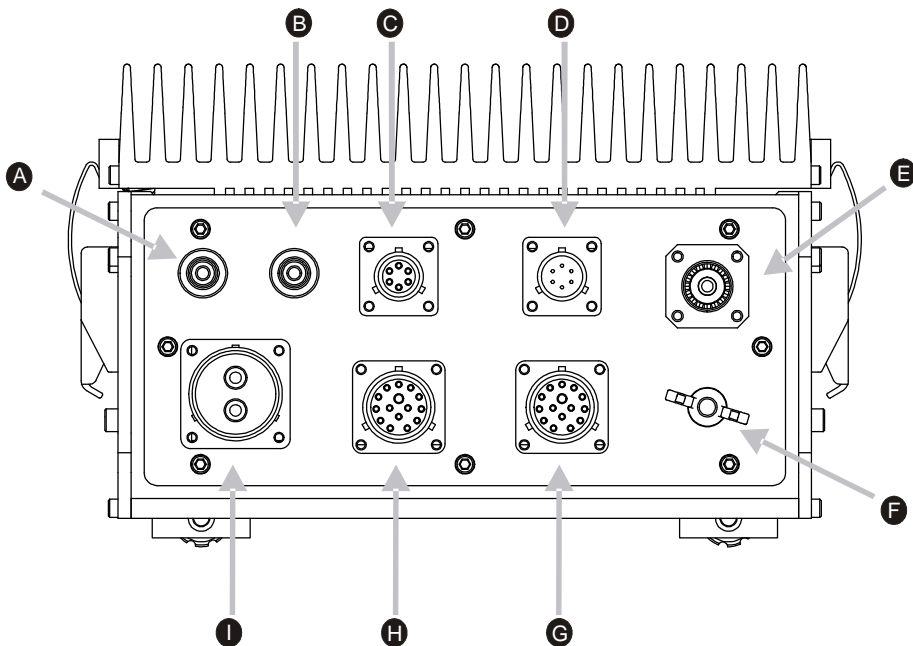

Connector	Name
A	CW
B	Speaker
C	ESU
D	ATU
E	RF
F	Ground Lug
G	Linear Interface
H	Auxiliary Interface
I	Power Connector

PRC-2090 Docking Station – Rear Panel Connector Pin Outs

ESU/CW Socket

6 pin waterproof panel mounted socket

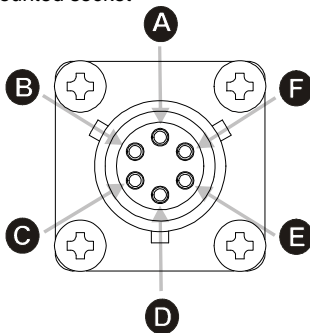

Pin	Name	Description of function	Level
A	1PPS	1 PPS from External Synchronisation Unit (ESU)	TTL
B	NMEA +	NMEA data input	+5VDC
C	+5	+5V for ESU power	+5VDC
D	CW key	CW key input	Active low 0V
E	Gnd	Ground	Ground 0V
F	N/C	Not connected	

**ATU Connector**

6 pin waterproof panel mounted socket

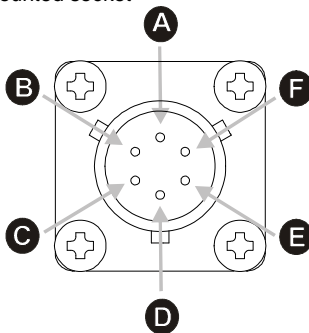

Pin	Name	Description of function	Level
A	Gnd	Ground	Ground 0V
B	NC	Reserved	
C	NC	Reserved	
D	Scan/Tune	Output - Initiate preamp.	Active Low
E	Tuned	Input - Tune result.	Low - Successful
F	+13V8 Fused	Fused 13.8VDC output	+13.8VDC

**Antenna RF Connector**

UHF RF Socket

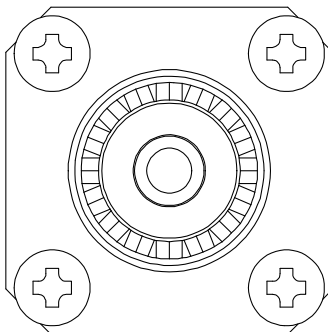

**Linear Amplifier Interface Socket**

15 pin waterproof panel mounted socket

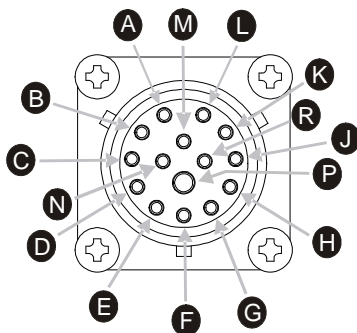

Pin	Name	Description of function	Level
A	+13V8 Fused	Fused 13.8VDC output	+13.8VDC
B	Aux Dig Out 0	Linear Data	Active Low
C	Aux Dig Out 1	Linear Clk	Active Low
D	Ext ALC	External Linear ALC	
E	Tuned	ATU Tuned Input	Active Low
F	Aux PTT	PTT in	Active low 0V
G	RS-232 Tx	RS-232 Tx data	True RS-232 levels
H	RS-232 Rx	RS-232 Rx data	True RS-232 levels
J	Aux Dig In 1	Scan stop input	Active low 0V
K	PTT Out	PTT output to external equipment	Active low 0V
L	Aux Dig Out 2	Auxiliary digital output (future use)	Active low 0V
M	NC	Reserved	
N	Fan	Fan Control	13.8V
P	Gnd	Ground	Ground 0V
R	NC	Reserved	



**Auxiliary Socket**

15 pin waterproof panel mounted socket

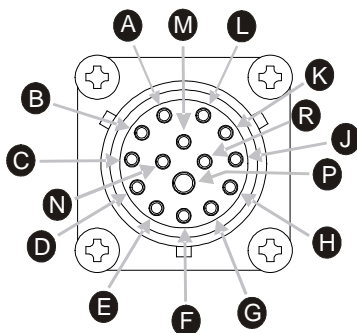

Pin	Name	Description of function	Level
A	+13V8 Fused	Fused 13.8VDC output	+13.8VDC
B	Bal Audio Out 1	Balanced audio out 1	600 Ω -6dBm to +9dBm
C	Bal Audio Out 2	Balanced audio out 2	600 Ω -6dBm to +9dBm
D	Bal Audio In 1	Balanced audio in 1	600 Ω -24dBm to 0dBm
E	Bal Audio In 2	Balanced audio in 2	600 Ω -24dBm to 0dBm
F	Aux PTT	PTT in	Active low 0V
G	RS-232 Tx	RS-232 Tx data	True RS-232 levels
H	RS-232 Rx	RS-232 Rx data	True RS-232 levels
J	Scan Stop	Scan stop input	Active low 0V
K	PTT Out	PTT output to external equipment	Active low 0V
L	Aux Dig Out 2	Auxiliary digital output (future use)	Active low 0V
M	External MICH	Balanced Microphone input high	
N	Speaker	Loudspeaker output	0-10V
P	Gnd	Ground	Ground 0V
R	External MICL	Balanced Microphone input low	

**Power Connector**

2 pin waterproof panel mounted socket

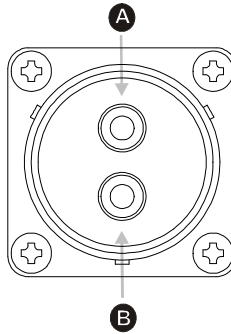

Pin	Name	Description of function	Level
A	+13V8 Vin	13.8VDC input	+13.8VDC
B	Gnd	Ground	Ground 0V

**2019 Automatic Tuning Mobile HF Antenna - Barrett P/N 2019-00-10**

The 2019 antenna plugs directly into the "ATU" and "RF" connectors located on the rear of the PRC-2090 docking station using the cables supplied.

**Important:-** PRC-2090 transceivers must have the 2019 antenna option set during programming.

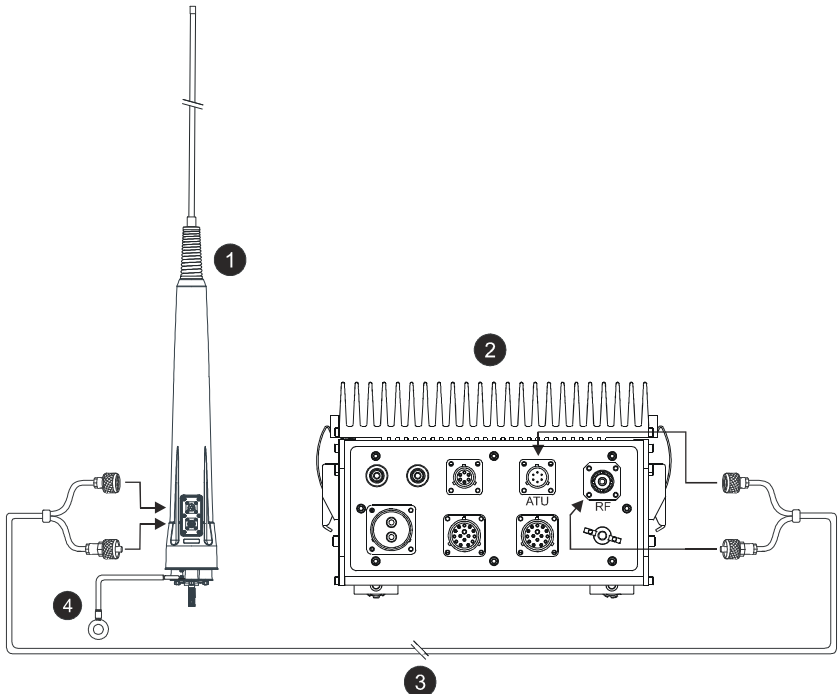
**2019 Antenna to PRC-2090 Docking Station Connection Diagram**

- 1 2019 automatic tuning HF mobile antenna
- 2 PRC-2090 vehicle docking station
- 3 Interface cable - integral coaxial/control
- 4 Earth cable

### **Mounting the Barrett 2019 Automatic Tuning Mobile HF Antenna**

The Barrett 2019 antenna should be mounted in positions similar to those illustrated in the diagrams on the following pages. Select a position free from excessive vibration. A bracket, fabricated to withstand the forces and vibration that can be expected during off-road driving, should be used to mount the antenna to the vehicle. When locating the mounting position for the antenna ensure that the antenna body, when flexing on its vibration mount, cannot come into contact with other parts of the vehicle. The antenna should be mounted as far from surrounding objects on the vehicle as possible.

The antenna is supplied with one middle section and one top whip section (Barrett P/N: BCA201901), a tapered black spring (Barrett P/N: BCA201903), an antenna installation guide and a pre-terminated 6 metre control cable to suit the Barrett 2019 antenna to transceiver. A 6 metre (Barrett P/N: BCA201904) or 10 metre (Barrett P/N: BCA201902) extension cable for the control cable is also available.

The control cable should be routed into either the engine compartment or boot (trunk) of the vehicle. If the joint between the antenna control cable and the extension cable is in an exposed position, a butyl rubber self amalgamating tape should be used to seal the joint. Do not wrap this joint if it cannot be made completely water tight as water will collect in the joint and cause it to corrode.

**A good earth (ground) to the main body of the vehicle is essential for efficient operation of the antenna.** To achieve this clean all joints to bare metal and use copper braid earth straps if any non-metallic joints are encountered.

After mounting the main body of the antenna, screw the black base spring onto the antenna body followed by the whip section.

#### **Important Information**

**It is ESSENTIAL to maintain the minimum clearances between the antenna and surrounding metal work as indicated in the diagrams. FAILURE TO MAINTAIN THESE CLEARANCES WILL NOT ONLY REDUCE THE EFFICIENCY OF THE BARRETT 2019 AUTOMATIC TUNING MOBILE HF ANTENNA BUT MAY ALSO LEAD TO INTERNAL RF ARCING AND FAILURE.**

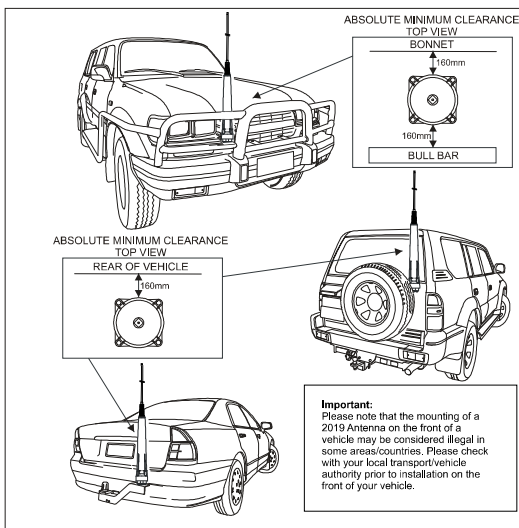
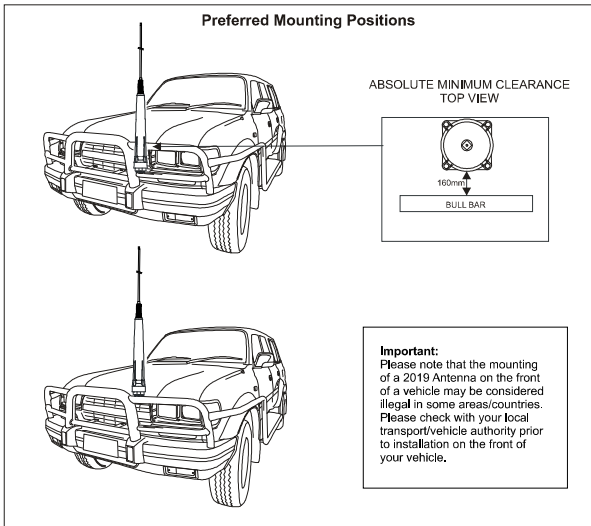

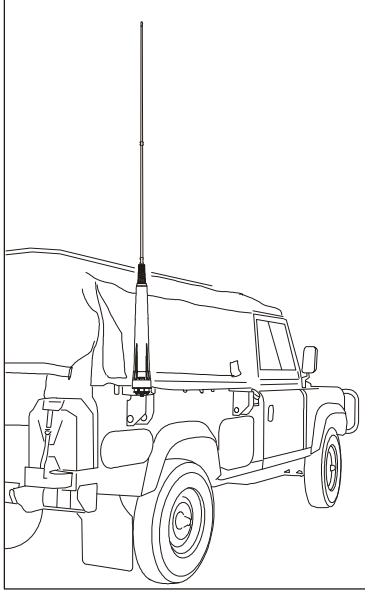

Typical Military Vehicle Mounting Example

**Caution:- Whilst the 2019 automatic tuning mobile HF antenna is designed to withstand vibration to military specifications on tyred vehicles, some mounting positions on large prime-movers, particularly front mounted bull bars, are subject to vibration that far exceeds this specification. Do not mount the 2019 antenna in positions such as these as damage to the antenna may result.**

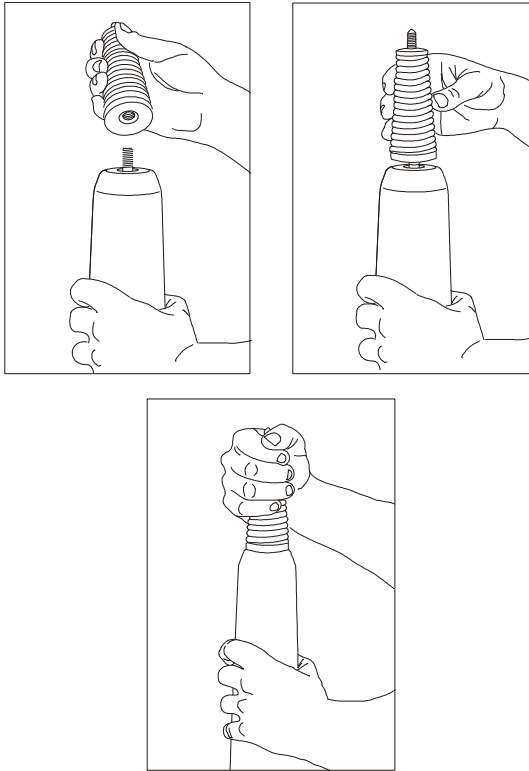
**Antenna Assembly****Mounting the Base Spring**

The base spring should only ever be hand tightened, if a tool is used it may damage the spring base.

**Mounting the Whip Sections**

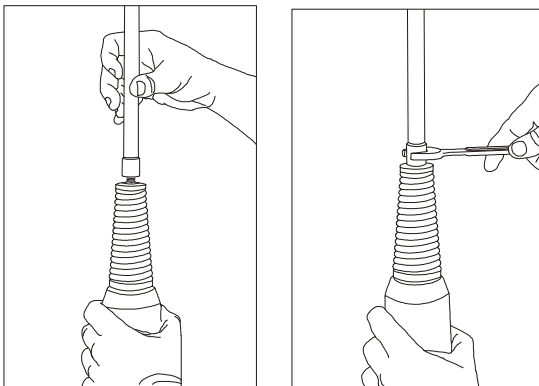

To mount the whip section it is recommended that only one section of the whip is screwed onto the antenna at a time. The whip section should be hand tightened fully then a suitable tool (ie: a spanner) can be used to tighten the section a further 10 to 20 degrees clockwise while holding the antenna body with a free hand.

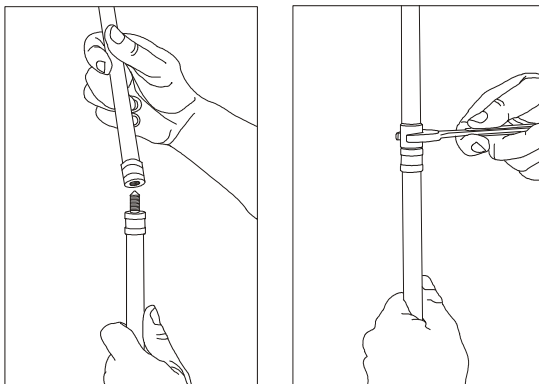

To mount 2 whip sections together the unattached whip section should be hand tightened fully then a suitable tool (ie: a spanner) can be used to tighten the section a further 10 to 20 degrees clockwise while holding the already screwed on whip section with a free hand.



### **Testing the Barrett 2019 Automatic Tuning Mobile HF Antenna**

To test the Barrett 2019 antenna, first select the lowest transmit frequency in the transceiver and press the TUNE key. The display should show the word "Tuning" for a few seconds, followed briefly by "Tune Passed" and an indication of the measured VSWR (Voltage Standing Wave Ratio) value. Check this reading against the VSWR meter.

Repeat the above test on the highest frequency in the transceiver and on a selection of frequencies in between at approximately 2 MHz intervals. If the tune passes at all times the Barrett 2019 antenna is working correctly. The Barrett 2019 antenna tunes to maximise whip current, not minimise VSWR, but the displayed VSWR value should generally be between 1.0:1 and 2.0:1. However, if the display shows "Autotune Fail" accompanied by low pitched beeps at any point, the Barrett 2019 antenna has failed tune. Confirm the "Antenna Type" is selected as either "910 Mobile Antenna" or "2019 Mobile Antenna" in the transceiver Protected Menu I/O settings field. Check all cables are correctly connected, check the earth cable from the base of the Barrett 2019 antenna has a good connection to the vehicle body (not chassis or battery), check the whip fitted is not faulty or incorrect and move the vehicle if the Barrett 2019 antenna is close to any metal fences, buildings etc. If the problem cannot be resolved, contact your dealer or Barrett Service Department for advice.

**910 Automatic Tuning Mobile Antenna - Barrett P/N BC91000**

The 910 antenna plugs directly into the rear of a PRC-2090 fitted into the PRC-2090 Vehicle docking station or the PRC-2090 Base docking station transceiver using the cables supplied. **Important:-** PRC-2090 transceivers must have the 910 antenna option set during programming.

The 910 antenna should be mounted in positions similar to those illustrated in the diagrams below. Select a position free from excessive vibration. A bracket, fabricated to withstand the forces and vibration that can be expected during off-road driving, should be used to mount the antenna to the vehicle. When locating the mounting position for the antenna ensure that the antenna body, when flexing on its vibration mount, cannot come into contact with other parts of the vehicle. The antenna should be mounted as far from surrounding objects on the vehicle as possible.

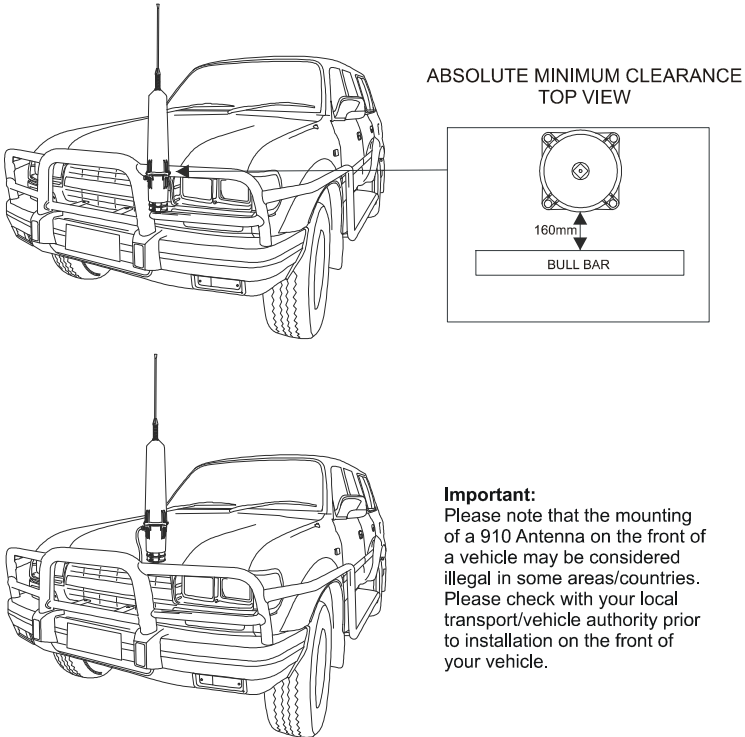
**Preferred Mounting Positions**

**Acceptable Mounting Positions**

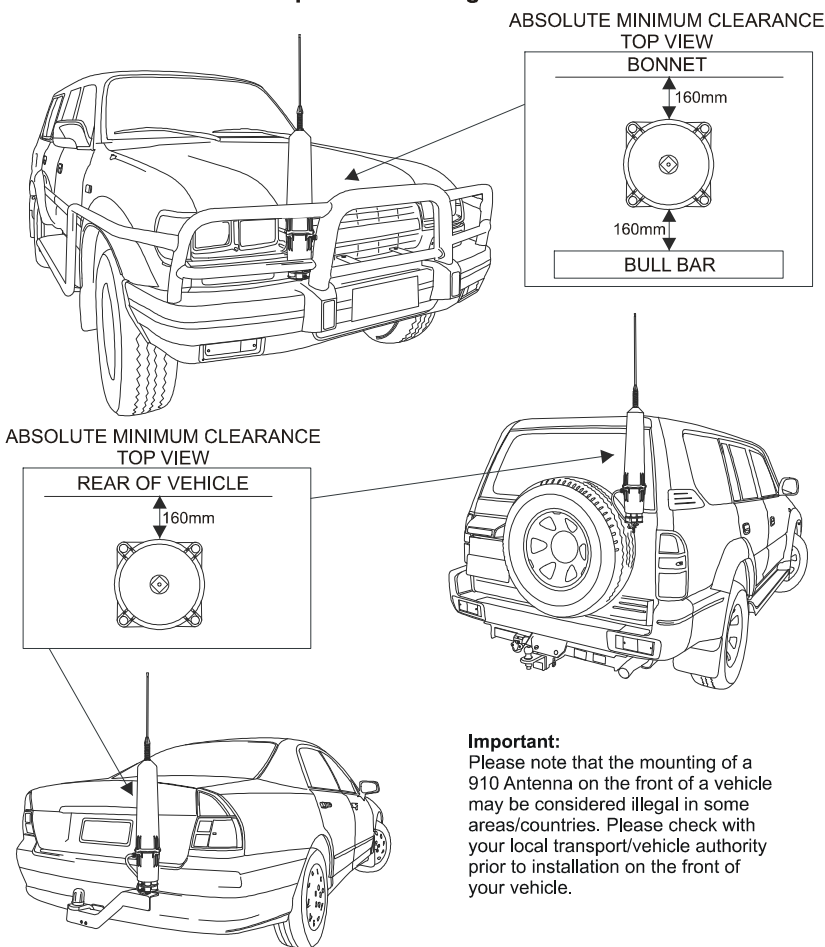

**Caution:-** Whilst the 910 automatic tuning mobile antenna is designed to withstand vibration to military specifications on tyred vehicles, some mounting positions on large prime-movers, particularly front mounted bull-bars, are subject to vibration that far exceeds this specification. Do not mount the 910 antenna in positions such as these as damage to the antenna may result.

**A good earth (ground) to the main body of the vehicle is essential for efficient operation of the antenna.** To achieve this clean all joints to bare metal and use copper braid earth straps if any non-metallic joints are encountered.

After mounting the main body of the antenna, screw the black coil onto the antenna body followed by the stainless steel whip.

**Note:-** Some models of the 910 antenna have a one piece spring and a stainless steel whip in place of the coil and whip.

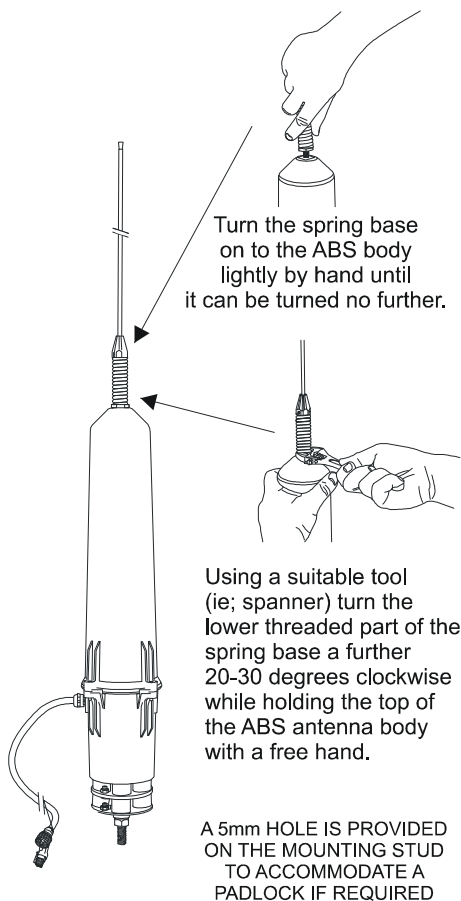

The antenna is supplied with a pre-terminated 1.5 metre cable tail. This should be routed into either the engine compartment or boot (trunk) of the vehicle. A 6 metre pre-terminated extension cable is supplied to connect the antenna to the transceiver (this cable may be extended to 12 metres by use of another extension cable). If the joint between the antenna stub cable and the extension cable is in an exposed position, a butyl rubber self amalgamating tape should be used to seal the joint. Do not wrap this joint if it cannot be made completely water tight as water will collect in the joint and cause it to corrode.

To test the antenna, attach a VSWR meter in line with the coaxial cable at the transceiver. Select any channel on the transceiver and activate PTT or use the tune function on the transceiver. The antenna should tune (indicated by the sound of relays clattering), within 2 seconds. Use the tune function to check the VSWR of the antenna, it should be less than 2:1. If the tune sequence does not occur check all wiring thoroughly and check that the transceiver is programmed for use with a 510/910 antenna. If the VSWR is not within an acceptable limit check the earth (ground) bonding of the antenna base to the vehicle.

To secure the whip if driving under low objects or for use of the 910 in an NVIS mode (for short range communication) secure the whip as illustrated in the diagram below with the steel wire clip and lanyard supplied.

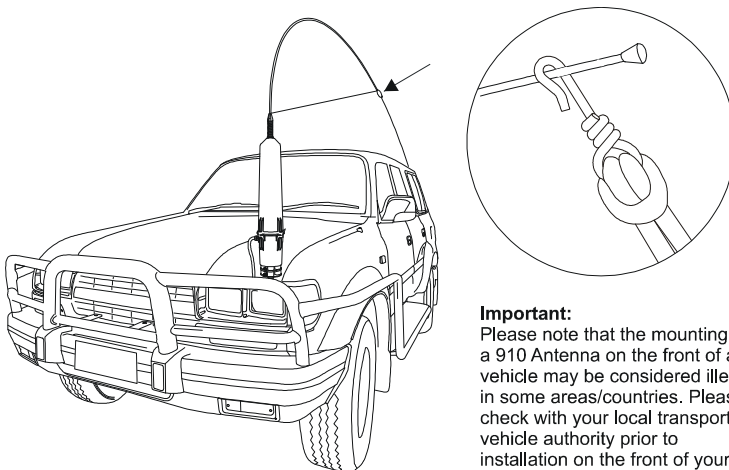

**Important:**

Please note that the mounting of a 910 Antenna on the front of a vehicle may be considered illegal in some areas/countries. Please check with your local transport / vehicle authority prior to installation on the front of your vehicle.

## **Overview of HF Operation**

HF (High Frequency) is the radio spectrum with frequencies between 1.6 and 30 MHz. Within this radio spectrum an efficient form of transmitter modulation, SSB (Single Side Band), is used. This, combined with the use of the ionosphere - a layer of ionisation gases that resides between 100 and 700km above the earth's surface, provides efficient, cost effective communications over short, medium and long distances - without the need for expensive re-transmission devices, such as the VHF or UHF repeaters or satellites, all of which have on going operational costs and a reliance on a physical infrastructure.

In many remote areas, HF/SSB is the only form of communication possible.

## **HF Propagation**

When HF/SSB radio waves are generated by the transceiver there are usually two components:-

- The ground-wave, which travels directly from the transmitting antenna to the receiving antenna following the contours of the earth.
- The sky-wave, which travels upward and at an angle from the antenna, until it reaches the ionosphere (an ionised layer high above the earth's surface), is refracted back down to earth, to the receiving antenna.

Generally speaking, ground-wave is used to communicate over shorter distances usually less than 50km. Because ground-wave follows the contours of the earth, it is affected by the type of terrain it passes over. Ground wave is rapidly reduced in level when it passes over heavily forested areas or mountainous terrain.

Sky-wave is used to communicate reliably over medium to long distances up to 3,000km. Whilst the nature of sky-wave propagation means it is not affected by the type of terrain as in ground waves it is affected by factors involving the ionosphere as described below.

### Radio Wave Propagation Illustrated

The following illustrations show the characteristics of ground-wave and sky-wave propagation during day and night time. In each illustration the height of the ionosphere above the ground is shown.

In both illustrations Station A communicates with Stations B, C and D. Propagation from Station A to B is by ground-wave. The diagrams illustrate that the ground wave is not affected by the time of day and the height of the ionosphere above the ground.

Propagation from Station A to C and D, however, is by sky-wave and as the diagrams illustrate the sky wave is significantly affected by the time of day and the height of the ionosphere above the ground.

Under each diagram there are recommended working frequencies listed. Please note that these will vary according to time of year and other factors. They are intended only as a guide and are subject to change.

#### Day

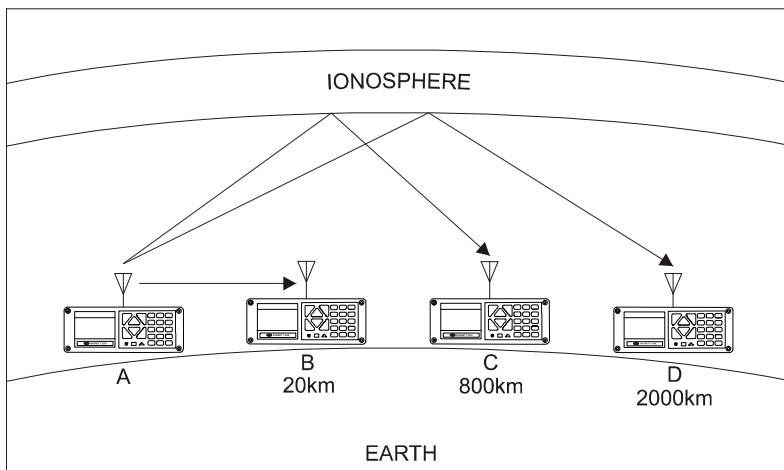

**The sun is higher, the ionosphere is higher, the best frequency to use is higher**

- A to B - Possible optimum working frequency is 3 MHz
- A to C - Possible optimum working frequency is between 7 - 9 MHz
- A to D - Possible optimum working frequency is between 13-16 MHz

**Night**

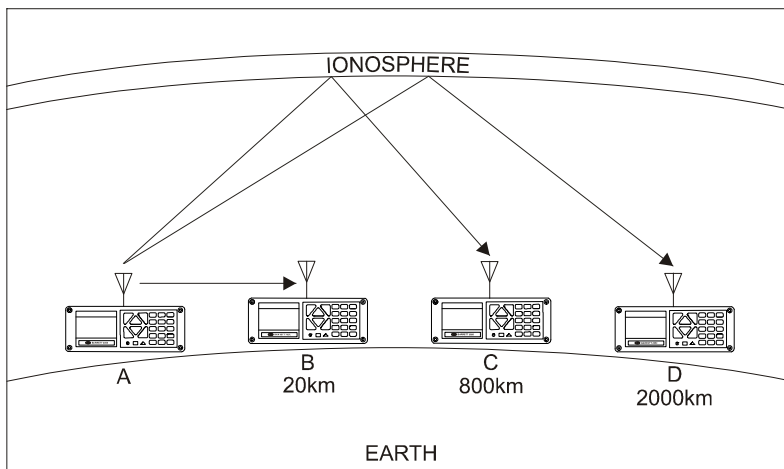

**The sun is lower, ionosphere is lower, best frequency to use is lower**

- A to B - Possible optimum working frequency is 3 MHz
- A to C - Possible optimum working frequency is between 5 - 7 MHz
- A to D - Possible optimum working frequency is between 9 - 12 MHz

**Factors Which Affect HF/SSB Communications**

There are a number of different factors which will affect the success of your communications via HF/SSB radio. These are outlined below:-

**Frequency Selection**

Frequency selection is perhaps the most important factor that will determine the success of your HF/SSB communications.

Generally speaking the greater the distance over which you want to communicate, the higher the frequency you should use.

Beacon Call, a Selcall (Selective Call) function built into the Barrett 950 transceiver, makes finding the correct frequency to use easy. Beacon Call is based on the network transceivers all having a selection of frequencies that will accommodate most ionospheric conditions. When in standby the network transceivers scan these frequencies waiting for a call (Selcall or Beacon Call) from another transceiver. The transceiver wishing to check for the best frequency to operate on sends a Beacon Call to the station he wishes to contact. If his call to the other station is successful he will hear a revertive call from the station he is calling, indicating the channel he selected was suitable for the ionospheric conditions prevailing. If he does not hear this revertive call or it is very weak, he tries on another channel until a revertive call of satisfactory signal strength is heard.



(Refer to Selcall (Selective Call) section of this manual for full details on Beacon Call operation.)

### **Time of Day**

As a rule, the higher the sun, the higher the frequency that should be used. This means that you will generally use a low frequency to communicate early morning, late afternoon and evening, but you will use a higher frequency to cover the same distance during times when the sun is high in the sky (e.g. midday). You will need to observe the above rule carefully if your transceiver has a limited number of frequencies programmed into it, as you may only be able to communicate effectively at certain times of the day.

### **Weather Conditions**

Certain weather conditions will also affect HF/SSB communications. Stormy conditions will increase the background noise as a result of 'static' caused by lightning. This background noise could rise to a level that will blank out the signals you are trying to receive.

### **Man-made Electrical Interference**

Interference of an electrical nature can be caused by overhanging power lines, high power generators, air-conditioners, thermostats, refrigerators and vehicle engines, when in close proximity to your antenna. The result of such interference may cause a continuous or intermittent increase in the level of background noise.

### **System Configuration and Installation**

The method in which your system is configured and installed will also affect the success of your HF/SSB communications. Your choice of antenna system and power supply is critical. Correct installation is also extremely important. An HF/SSB transceiver is generally installed using different rules to those used to install VHF or UHF transceivers. Failure to correctly install an HF/SSB system will greatly affect the communications quality you will obtain. Refer to the installation section of this manual for details.

Your local Barrett representative will be able to assist with your system configuration and/or installation.

### **Special Note - HF Communications Compared with VHF or UHF Short Distance Communications**

Communications on any HF/SSB transceiver will sound different to that on a VHF (Very High Frequency) radio or UHF (Ultra High Frequency) radio or telephone. This is because of the nature of HF propagation and the modulation methods used. On HF/SSB transceivers there will always be background noise evident behind the signal you are receiving and this will increase when there is electrical interference or thunderstorm activity in the area.

### **Limited 3 Year Warranty**

Barrett Communications Pty Ltd provides a maximum three year warranty on all equipment it manufactures which is to be used expressly for high frequency, single sideband radio communications. This warranty covers faults arising from defects in design, workmanship or materials. Please note that this warranty does not cover batteries.

As the Barrett PRC-2090 Tactical HF Radio System is fully immersible to 1 metre, it is imperative that the transceiver is not opened. The warranty for the PRC-2090 will be void if the transceiver is opened by anyone other than Barrett Communications Pty Ltd staff

Should any fault due to bad design, workmanship or materials be proven at any time within the warranty period, the company will rectify such fault free of charge providing the equipment is returned freight paid to Barrett Communications Pty Ltd or to an authorised service centre. The warranty period for all products is twelve months after shipment from the factory or an authorised Barrett agent or dealer. In the event that the end user completes and lodges warranty registration documents within three months of receipt of the shipment from the factory or an authorised Barrett agent or dealer, the warranty period shall be extended by an extra twenty four months giving a total warranty period of three years.

This warranty shall not cover any abuse, accident, improper installation, connection, adjustment or use other than in accordance with the instructions issued by the company.

In addition, this warranty shall not cover the distance which transceiver products will operate over or quality of transmission or reception as a result of unfavourable environmental conditions. Nor shall this warranty cover the quality of transmission and reception of transceivers mounted in vehicles or vessels that have not been sufficiently electrically suppressed.

Subject to the matters set out in this warranty, no liability, expressed or implied is accepted for any consequential loss, damage or injury arising as a result of a fault in the equipment and, all expressed or implied warranties as to quality or fitness for any purpose are hereby excluded.

This warranty does not extend to products supplied by the company which are not designed or manufactured by it. Barrett Communications Pty Ltd will however make every endeavour to ensure that the purchaser receives full benefit on any warranty given by the manufacturer.

This warranty is restricted to the original purchaser. Where the original purchaser is a reseller who has purchased for the purpose of resale, warranty shall be extended to the reseller's customer.

## **Warranty Registration and Customer Support**

Thank you for purchasing Barrett HF communications products.

The standard and automatic warranty on Barrett products is one year. By completing the registration form on the next page and sending it to us by mail, fax or email, this warranty will be extended to a total of three years at no extra cost.

By registering for the extended warranty period Barrett Communications will also provide the following services:-

**Your contact details will be registered against the serial numbers of the equipment.**

**Barrett Communications will keep you informed of any developments relating to this equipment.**

**Barrett Communications will provide you with direct access to a support telephone contact line manned from 0000hrs GMT to 1600 Hrs GMT, 7 days a week.**

The registration forms can be returned by mail, (no postage stamp required in Australia) or by facsimile (08) 9418 6757 (International + (618) 9418 6757).

If you have access to the Internet you can use the warranty registration page in the support section of our website to register your warranty form. Please go to [www.barrettcommunications.com.au](http://www.barrettcommunications.com.au)

We will mail or email you if you have registered via the Internet details of your support package within 7 days of receiving your completed registration form.

Barrett Communications is proud of its reputation for support of its customers. This registration process has been introduced so that we may continue to improve our level of support to you.