

# **5090RF**

# **Multi-Channel**

*KEYBOARD*

**User' s Guide**

Version 1.0

The information in this document is subject to change without notice and does not represent a commitment on the part of the vendor.

No warranty of representation, either expressed or implied, is made with respect to the quality, accuracy or fitness for any particular purpose of this document. The manufacturer reserves the right to make changes to the content of this document and/or the products associated with it at any time without obligation to notify any person or organisation of such changes.

In no event will the manufacturer be liable for direct, indirect, special, incidental or consequential damages arising out of the use or inability to use this product or documentation, even if advised of the possibility of such damages.

Copyright © July 1998, 1999, 2000. All rights reserved

IBM, PC/AT and PS/2 are registered trademarks of International Business Machines Corporation.

Microsoft, Windows, and Windows NT are registered trademarks of Microsoft Corporation in the United States of America and/or other countries.

All other trademarks are trademarks of their respective holders.

## FCC GUIDELINES

This equipment has been tested and found to comply with the limits for a Class B digital device, pursuant to Part 15 of the FCC Rules. These limits are designed to provide reasonable protection against harmful interference in a residential installation. This equipment generates, uses and can radiate radio frequency energy and, if not installed and used in accordance with the instructions may cause harmful interference to radio communications. However, there is no guarantee that interference will not occur in a particular installation. If this equipment does cause harmful interference to radio or television reception, which can be determined by turning the equipment off and on, the user is encouraged to try to correct the interference by one or more of the following measures:

- Reorient or relocate the receiving antenna
- Increase the separation between the equipment and receiver
- Connect the equipment into an outlet on a circuit different from that to which the receiver is connected.
- Consult the dealer or an experienced radio/TV technician for help.

The Class B digital apparatus meets all requirements of the Canadian Interference-Causing Equipment Regulation.

Cet appareil numérique de la class B respecte toutes les exigences du Règlement sur le matériel brouilleur du Canada.

### **Caution**

*Any changes or modifications not expressly approved by the party responsible for compliance could void the user's authority to operate this equipment. Shielded*

*interface cable, if any, must be used in order to comply with emission limits.*



## INTRODUCTION

The 5090RF is not only a radio frequency multi-channel keyboard but also a multimedia keyboard. This wireless keyboard is designed to make your life easier. It is just the right size and weight thus makes it easy to hold in hand or put on your laps, anywhere in the room. It's easy to touch and is quiet to the ears. Very wide-angle and long-distance detection frees you from your desktop. In addition, with sleep mode power saving and "book-on-keyboard protection", it's even easier to use battery in any environment.

With additional 15 multimedia buttons, this multimedia keyboard embeds many useful multimedia functions. By simply pressing a button, the user can arrive at the function they desire. In addition, the accompanying software supplies functions to organize these multimedia buttons and to customize a Shortcut button that provides you to access to the documents and programs you most often used. Using Multimedia Keyboard makes work more efficient and has more fun.

## Features

- ◆ So very wide scope of operating range and angles that the angles limitation of this keyboard to be the lowest
- ◆ Built-in button mouse is compatible with Microsoft® mouse and PS/2 mouse
- ◆ Book-on-keyboard protection
- ◆ Power saving
- ◆ This keyboard can be used under Windows NT®, Windows® 2000, Windows® 98 and Windows® 95 operating system or any O.S. compatible with them.
- ◆ Full size key (pitch 19.05 cm)
- ◆ Long "Travel" range (key depression distance)
- ◆ Long-distance detection

## Caution

☞ *Please read this User's Guide from beginning to end carefully. Especially INSTALLATION section from next page will tell you how to apply the additional 15-multimedia buttons on the top of your keyboard.*

## INSTALLATION

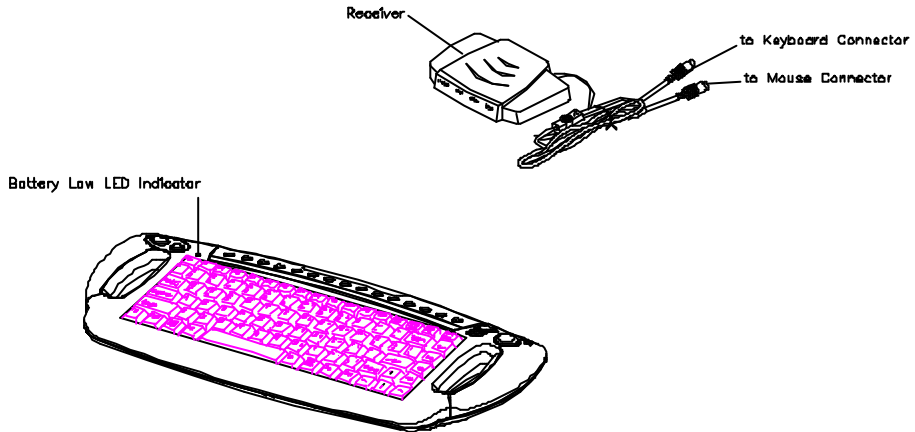

Figure 1: Keyboard Installation

- **Battery Low LED Indicator:**
  - (1). It is always not bright when the keyboard doesn't be typed. If the electricity of battery full and you typing, it is never bright too.
  - (2). Otherwise, if the battery low it would be lighted up to indicate the battery wore out.
- **Book-on-Keyboard Protection and Power Saving Features:**
  - (1). Prolong the life of this keyboard.
  - (2). Whenever you don't type any key over 100 mini seconds the 5090RF keyboard will sleep.
  - (3). If the keyboard is pressed accidentally over 20 seconds it will sleep too.

1. Check the two connectors of the receiver. The purple one should be plug in PS/2 keyboard port, and the other one could be green for plugging in PS/2 mouse port.

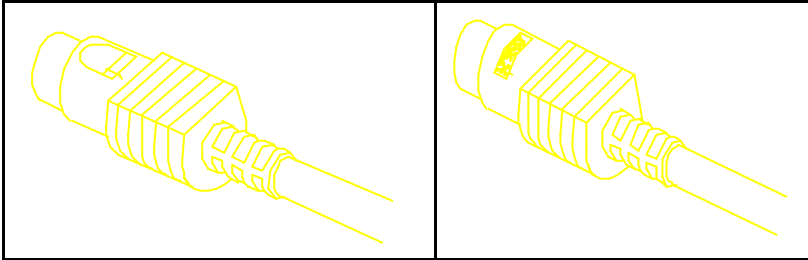

Figure 2: The receiver has 2 connectors. One with keyboard icon is keyboard connector, and the other one with mouse icon is mouse connector.

2. Connect the receiver with your computer system. Plug the purple connector in the PS/2 keyboard port, and the green one in the PS/2 mouse port on your computer system.
  - ☞ ***Heartily advise you to put the receiver in front of the computer system as well as monitor. In addition, the receiver needs to be placed far away the magnetic jam source, such as: motor, monitor.... The reason is that the magnetic field caused by the magnetic jam source will interfere the receiver working, and the interference will cause data reading error or missing.***
  - ☞ ***Before start the computer system, you should plug mouse connector in mouse port well. Otherwise, your computer system would not detect the mouse device, but takes that you do not install mouse.***
3. On the rear of the keyboard is equipped with battery and DIP switch for altering frequency channel.

4. Removing the battery cover and insert three batteries of AA (UM-3) type only. Make sure the polarities are correct.

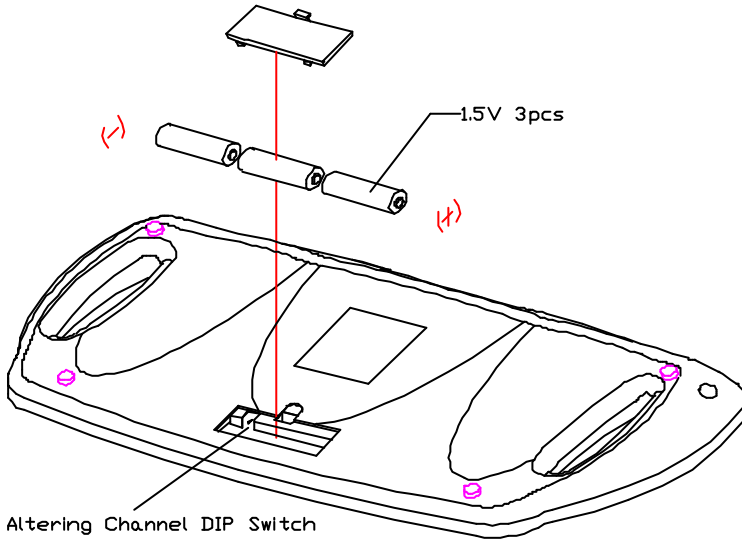
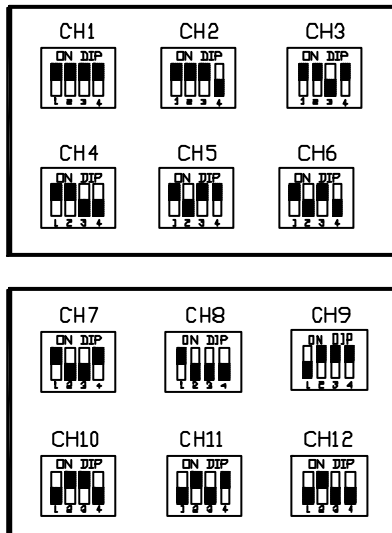

Figure 3: On the back cover of the keyboard is equipped with channel DIP switch and cell.

5. The keyboard provides 12 Frequency channels. Channel table as following:





- ☞ *The default channel is altered at channel 7 when it left the manufacture.*
  - ☞ *Taiwan area only can use channel 7 to channel 12.*
  - ☞ *The cellular phone channel both of the Taiwan and the China is 900 MHz.*
  - ☞ *The America area can use all these 12 channels.*
6. Place the 5090RF keyboard transmitter in front of the receiver sensor and no obstacles are between them, so the signal can be correctly sent. The effective distance may reach 10 meters that depends on the environment.
- ☞ *The 5090RF keyboard could be placed within very wide and effective angles surrounding the receiver.*
7. Power on your system and see if it works fine. The input method, whether keystrokes or click the button mouse, must be applied separately to avoid data reception loss and mistakes.
- ☞ *If your keyboard isn't working or it's working incorrectly, it could be that the keyboard isn't connected properly or a key is pressed during starting up. Repeat the installation steps like above.*
8. When the keyboard works fine, you should **install Multimedia Keyboard Driver**. Therefore the 15-multimedia buttons can work. For driver installation, you may refer to the instruction on the CD-ROM enclosed.
- ☞ *After installing the Multimedia Keyboard driver, the 15-multimedia buttons on your keyboard can work normally. **For multimedia button functions, please see online Help of the driver.***

### Caution

- ☞ *For the receiver may work fine it is strongly recommended do not alter the double-click speed of the mouse at the Fastest level, otherwise double-click built-in button mouse will not be detected by Windows.*

## USING EMBEDDED NUMERIC KEYPAD

The embedded numeric keypad consists of 15 keys and functions in three ways:

- ♦ As a part of the main keyboard.
- ♦ As a numeric keypad.
- ♦ As a cursor movement keypad.

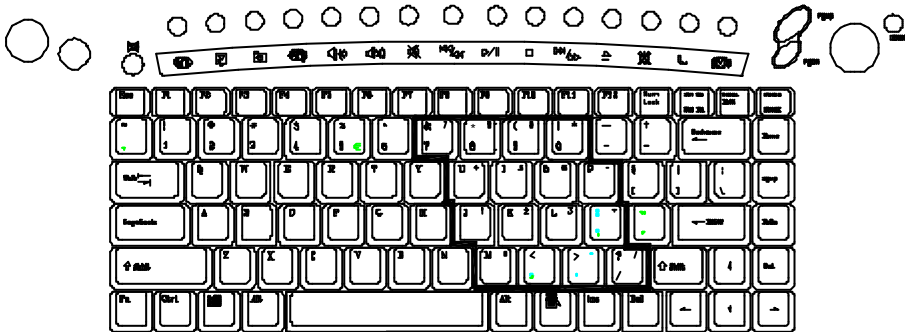

F

*figure 4: as a part of the main keyboard*



*Figure 5: as a numeric keypad*



*Figure 6: as a cursor movement keypad*

There are three keys to activate the embedded numeric keypad: **[Num Lock]**, **[Fn]**, and **[Shift]**.

**[Num Lock]:** This is a toggle key. The Num Lock LED indicator is default set to off. When the **[Num Lock]** key is pressed, the Num Lock LED indicator on the receiver is lit and the embedded numeric keypad function is activated.



**[Fn]** and **[Shift]**: These keys are used in conjunction with the **[Num Lock]** key and work only when pressed.



For accessing the embedded numeric keypad, please refer to the following table:

When Num Lock is <b>OFF</b> (default), the 15 keys of embedded numeric keypad works as a part of main keyboard. You can:	
Press:	To:
<b>[Fn]</b> *	Temporarily enable the cursor movement function.
<b>[Fn]</b> * + <b>[Shift]</b> *	Temporarily enable the embedded numeric keypad, cursor movement and highlighting functions.
<b>[Num Lock]</b>	Enable the embedded numeric keypad. Lights the Num Lock LED indicator.
When Num Lock is <b>ON</b> , the 15 keys of embedded numeric keypad work as a numeric keypad. You can:	
Press:	To:
<b>[Fn]</b> *	Temporarily revert to the main keyboard.
<b>[Fn]</b> * + <b>[Shift]</b> *	Temporarily enable uppercase function of the main keyboard.
<b>[Num Lock]</b>	Disable the embedded numeric keypad. Turns off the Num Lock LED indicator.

\* *Press and hold the key(s) during operation.*

## **[Ctrl]**, , and **[Enter]** keys

Most keyboards have two **[Ctrl]** keys, two  keys on both left and right sides, and a smaller **[Enter]** key on numeric keypad. Although this keyboard doesn't have right **[Ctrl]** key, right  key and **[Enter]** (numeric keypad) key, it still supports the functions.

- **[Fn]** + left **[Ctrl]** = right **[Ctrl]**
- **[Fn]** + left  = right 
- **[Fn]** + main **[Enter]** = (on Numeric Keypad) **[Enter]**

## TECHNICAL SPECIFICATIONS

### Electrical Data

Input power : 4.5 VDC (three AA batteries)  
Switch activation mechanism : Membrane  
Transmission : Radio Frequency (910.2 ~ 919.7 MHz)  
Multi-Channel (12 Channels)

Channel & Frequency table:

Channel	Frequency	Channel	Frequency	Channel	Frequency
1	910.2 MHz	5	914.2 MHz	9	917.2 MHz
2	910.7 MHz	6	914.7 MHz	10	917.7 MHz
3	912.2 MHz	7	915.2 MHz	11	919.2 MHz
4	912.7 MHz	8	915.7 MHz	12	919.7 MHz

Rated RF output power level : 0.002mW (maximum)

### Physical & Mechanical Data

Key numbers : 105 keys for U.S. version  
106 keys for European version  
108 keys for Japanese version  
Total travel :  $3.0 \pm 0.5$  mm  
Peak force (normal key) :  $55 \pm 20$  grams  
Keyboard dimension : 439 mm (L)  $\times$  210 mm (W)  $\times$  44 mm (H) mm  
Keyboard weight : 975 g (including battery)  
Receiver weight : 210 g  
Effective operating distance : 5 meters  
Battery life : 3 months in normal operating  
Modulation frequency : 900 MHz

5090RF Multi-Channel Keyboard User's Guide Version 1.0  
Hardware Installation

Transfer rate : 19.2 kbps  
Pre-Travel :  $1.0 \pm 0.5$  mm

## Environmental Data

Operating temperature	: 0°C to 45°C
Storage temperature	: -20°C to 60°C
Relative humidity	: 20% to 90% non-condensing
Altitude	: -1000 ft. to 10000 ft.

## Electromagnetic Data

SAFETY	: CSA, TÜV, and UL
EMC	: BCIQ, Canada FCC part 15, 227 Type acceptance- ETS 300 220 EMC - ETS 300 683

5090RF Multi-Channel Keyboard User's Guide Version 1.0  
Hardware Installation

3100504660  
Version 1.0  
February 2000  
Printed in China