

**9116IR**

**INFRARED  
KEYBOARD**

**User's Guide**

Version 1.0

The information in this document is subject to change without notice and does not represent a commitment on the part of the vendor.

No warranty of representation, either expressed or implied, is made with respect to the quality, accuracy or fitness for any particular purpose of this document. The manufacturer reserves the right to make changes to the content of this document and/or the products associated with it at any time without obligation to notify any person or organisation of such changes.

In no event will the manufacturer be liable for direct, indirect, special, incidental or consequential damages arising out of the use or inability to use this product or documentation, even if advised of the possibility of such damages.

Copyright © March 2000. All rights reserved

IBM, PC/AT and PS/2 are registered trademarks of International Business Machines Corporation.

Microsoft, Windows, and Windows NT are registered trademarks of Microsoft Corporation in the United States of America and/or other countries.

All other trademarks are trademarks of their respective holders.

## FCC GUIDELINES

This equipment has been tested and found to comply with the limits for a Class B digital device, pursuant to Part 15 of the FCC Rules. These limits are designed to provide reasonable protection against harmful interference in a residential installation. This equipment generates, uses and can radiate radio frequency energy and, if not installed and used in accordance with the instructions may cause harmful interference to radio communications. However, there is no guarantee that interference will not occur in a particular installation. If this equipment does cause harmful interference to radio or television reception, which can be determined by turning the equipment off and on, the user is encouraged to try to correct the interference by one or more of the following measures:

- ⌘ Reorient or relocate the receiving antenna
- ⌘ Increase the separation between the equipment and receiver
- ⌘ Connect the equipment into an outlet on a circuit different from that to which the receiver is connected.
- ⌘ Consult the dealer or an experienced radio/TV technician for help.

The Class B digital apparatus meets all requirements of the Canadian Interference-Causing Equipment Regulation.

Cet appareil numérique de la class B respecte toutes les exigences du Règlement sur le matériel brouilleur du Canada.

### **Caution**

- ⌘ ***Any changes or modifications not expressly approved by the party responsible for compliance could void the user's authority to operate this equipment. Shielded interface cable, if any, must be used in order to comply with emission limits.***

# INTRODUCTION

This product is not only an infrared wireless keyboard but also an Internet keyboard. This infrared keyboard is designed to make your life easier. It is just the right size and weight thus makes it easy to hold in hand or put on your laps, anywhere in the room. It's easy to touch and is quiet to the ears. In addition, with sleep mode power saving and "book-on-keyboard protection", it's even easier on the battery and the environment.

With additional 7 Internet buttons, this keyboard embeds many useful Internet functions. By just one keystroke, you can easily access the WWW and E-mail. More features and joys are waiting for your exploring. You will discover your performance will be enhanced with this keyboard.

## Features

- ✘ Wide scope of operating range and angles
- ✘ Long-distance detection
- ✘ Four ID codes to avoid interference
- ✘ Book-on-keyboard protection
- ✘ Power saving
- ✘ Additional Internet buttons
- ✘ Built-in button mouse is compatible with Microsoft? mouse and PS/2 mouse
- ✘ Keyboard compatible with Windows? NT? , Windows? 2000, Windows? ME, Windows? 98 and Windows? 95

### **Book-on-Keyboard Protection and Power Saving Features:**

- (1). Prolong the life of this keyboard.
- (2). Whenever you don't type any key over 100 mini seconds the keyboard will sleep.
- (3). If the keyboard is pressed accidentally over 20 seconds it will sleep too.

# INSTALLATION

## System Requirement

- ? IBM AT, PS/2 PC and its compatibles
- ? Microsoft® Windows® 95, Windows® 98, Windows NT® 4.0, Windows®2000 or Windows® ME operating system
- ? Microsoft Internet Explorer 5.0 or later version (for Internet buttons)

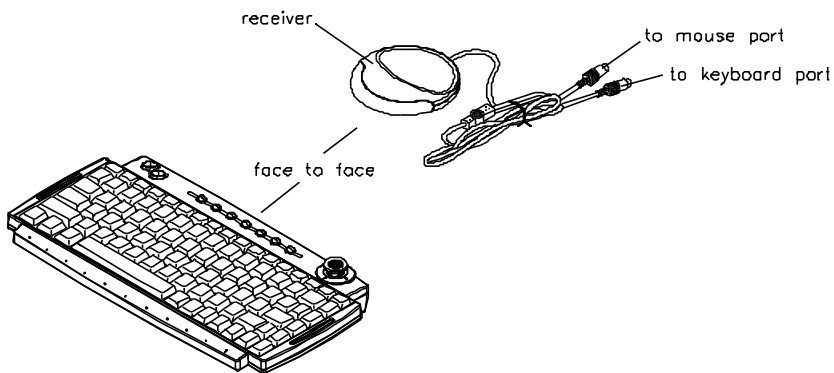

*Figure 1: 9116 IR Keyboard Installation*

**1. Setting a same ID Number for both keyboard and receiver.**

The pin 1 & pin 2 on the DIP switch are used for ID settings. (The other two pins, pin 3 and pin 4, are useless. You may ignore them.)

The table below indicates ID settings for four keyboards.

ID Number	DIP Switch	
	1	2
0	ON	ON
1	OFF	ON
2	ON	OFF
3	OFF	OFF

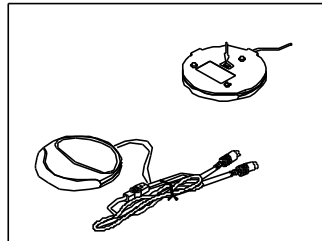

*Figure 2: The DIP switch is located on the back cover of the receiver and keyboard.*

2. On the rear of the keyboard, remove the battery cover and insert three batteries of AA (UM-3) type only. Make sure the polarities are correct.

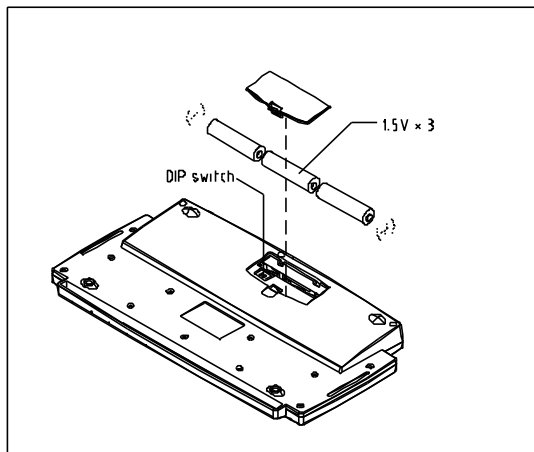

Figure 3: Back cover of the keyboard is equipped with DIP switch & dry cell .

- ⌘ *Make sure to set an identity code for each keyboard on both the keyboard and the receiver. You may change the ID number at any time, but make sure that the keyboard has power.*
  - ⌘ *Interference might occur if four keyboards are placed too close to each other and the angles between them are critical.*
3. Check the two connectors of the receiver. The purple one should be plug in PS/2 keyboard port, and the other one could be green for plugging in PS/2 mouse port.

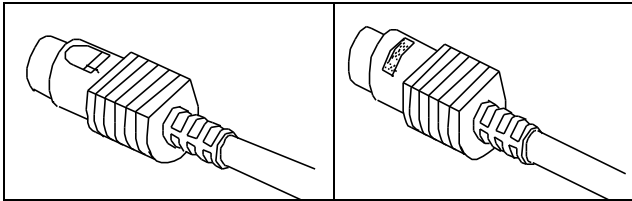

Figure 4: The receiver has two connectors. One with keyboard icon (purple one) is keyboard connector, and the other one with mouse icon (green one) is mouse connector.

4. Connect the receiver with your computer system. Plug the purple connector in the keyboard port, and the green one in the mouse port on your PC system.
  - ⌘ ***Heartily advise you to put the receiver in front of the computer system as well as monitor. In addition, the receiver needs to be placed far away the magnetic jam source, such as: motor, monitor... The reason is that the magnetic field caused by the magnetic jam source will interfere the receiver working, and the interference will cause data reading error or missing.***
5. Place the keyboard transmitter in front of the receiver sensor. The effective distance is 5 meters (16 feet).
  - ⌘ *The keyboard must be placed with its transmitter heading to the receiver sensor and no obstacles are between them, so the*

*signal can be correctly sent. The effective angle is  $\pm 45^\circ$  (horizontal),  $+60^\circ/-30^\circ$  (vertical).*







6. Power on your system and see if it works fine. The input method, whether keystrokes or click the button mouse, must be applied separately to avoid data reception loss and mistakes.
  - ✍ *If your keyboard isn't working or it's working incorrectly, it could be that the keyboard isn't connected properly or a key is pressed during starting up. Repeat the steps above.*
7. When the keyboard works fine, you should **install KeyMaestro keyboard driver.**

### **Caution**

- ✍ ***For the receiver may work fine it is strongly recommended do not alter the double-click speed of the mouse at the Fastest level, otherwise double-click built-in button mouse will not be detected by Windows.***

## INTERNET BUTTONS

The following Internet buttons are used with Microsoft Internet Explorer 5.0. To have these buttons work under Windows 95, Windows 98, or Windows NT4.0, the KeyMaestro keyboard driver enclosed is needed to install. Please refer to the file readme.htm in the disk for installation.

	Back	To return to the last page you viewed.
	Forward	To view the next page you viewed before.
	Stop	If a page you are trying to view is taking too long to open, click this button.
	Search	To gain access to a number of search providers.
	Web/Home	To start your Microsoft Internet Explorer 5.0 and bring up the home page you set.
	Favorites	To select a web page from your list of favourites.
	Mail	To open the default program you use for mail. If more than one email programs are installed, you may select <b>Tools -&gt; Internet Options -&gt; Programs -&gt; Email</b> to change the default setting from Internet Explorer.

### Battery Low Indication:

When the KeyMaestro keyboard driver had been installed, if battery low is occurred, the driver will display battery low and warning OSD (on screen display), in order that user can replace the exhausted battery with new or inspect what's happened. As for the detail behavior, please refer to the instruction on the diskette enclosed.



## USING EMBEDDED NUMERIC KEYPAD

The embedded numeric keypad consists of 15 keys and functions in two ways:

- ✍ As a part of the main keyboard.
- ✍ As a numeric keypad.

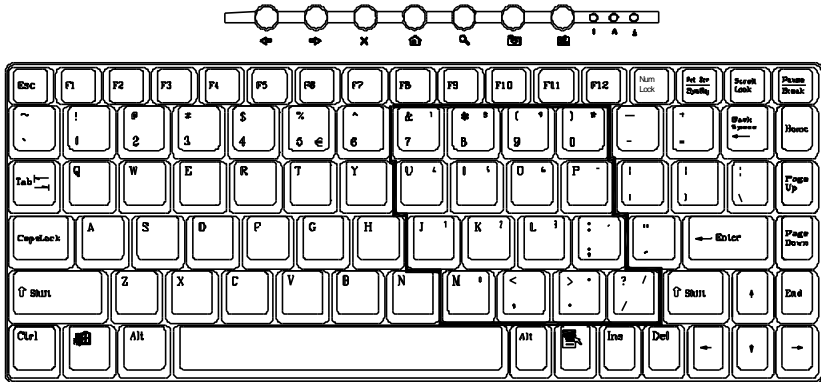

Figure 5: as a part of the main keyboard and as a numeric keypad

There are two keys to activate the embedded numeric keypad: **[Num Lock]** and **[Shift]**.

**[Num Lock]:** This is a toggle key. The Num Lock LED indicator is default set to off. When the **[Num Lock]** key is pressed, the Num Lock LED indicator on the receiver is lit and the embedded numeric keypad function is activated.

**[Shift]:** This key is working only when pressed.

- ✍ When Num Lock LED is on, pressing **[Shift]** with one of the numeric keys will change the numeric keypad to be a cursor movement keypad.
- ✍ When Num Lock LED is off, the **[Shift]** key works as normal. It transfers any pressed key into the upper case.

# TECHNICAL SPECIFICATIONS

## Electrical Data

Input power:	4.5 VDC (three AA batteries)
Switch activation mechanism:	Membrane
Transmission:	Infrared

## Physical & Mechanical Data

Key numbers:	86 keys for U.S. version 87 keys for European version 88 keys for Japanese version
Total travel:	3.0 ? 0.5 mm
Peak force (normal key):	55 ? 20 grams
Keyboard dimension:	380 mm (L) ? 187 mm (W) ? 35 mm (H)
Keyboard weight:	1.2 kg (including battery & receiver)
Effective operating distance:	5 meters (16 ft.)
Effective operating angle:	45? (horizontal), +60?/-30? (vertical)
Battery life:	2 months (4 keystrokes/sec., 4 hours/day).
Modulation frequency:	38 kHz
Transfer rate:	1.3 kbps
Pre-Travel:	1.0 ? 0.5 mm

## Environmental Data

Operating temperature:	0°C to 45°C
Storage temperature:	-20°C to 60°C
Relative humidity:	20% to 90% non-condensing
Altitude:	-1000 ft. to 10000 ft.

## Electromagnetic Data

SAFETY:	CSA, TÜV, and UL
EMC/ESD:	BCIQ, C-tick, and VCCI FCC part 15, subpart B, class B EN50081-1 & EN50082-1 (89/336/EEC)

## Receiver Specification

Input power:	5 VDC, 38 mA – 55mA
Connector type:	PS/2 for keyboard and mouse
Numbers of ID:	four (0 – 3)
LED:	NumLock, Caps Lock, Scroll Lock, Receiving Activation





