

# DX100

# User's Manual Bedienungsanleitung



Version 1.0 July 1998

**BEHRINGER®**  
ULTRA-LOW NOISE DESIGN

**PRO MIXER DX 100**  
PROFESSIONAL DJ MIXER WITH ULTRA-HIGH QUALITY

# PRO MIXER

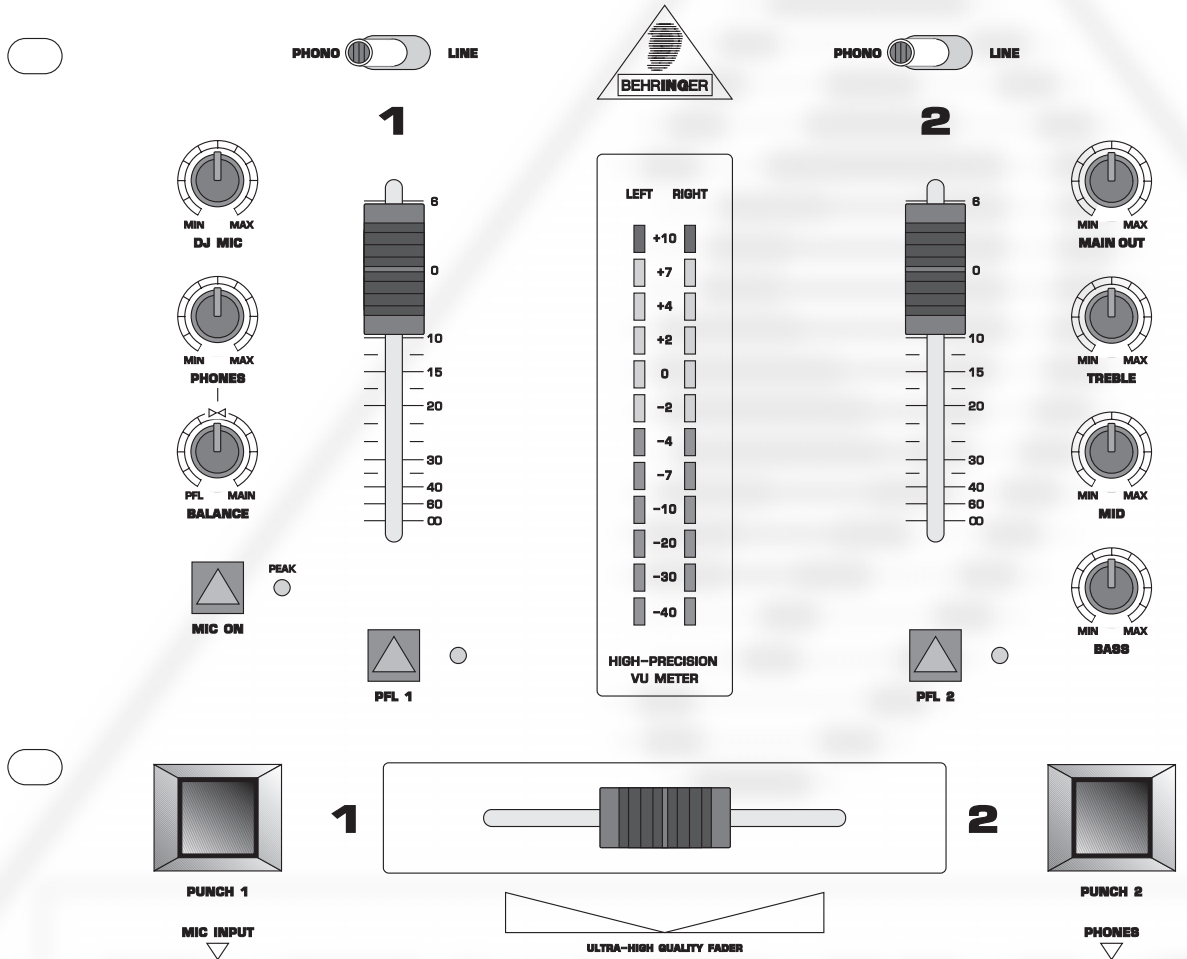

www.behringer.de



## EG-Declaration of Conformity



Spezielle Studiotechnik GmbH

### acc. to the Directives 89/336/EWG and 73/23/EWG

We,

**BEHRINGER INTERNATIONAL GmbH**

**Hanns-Martin-Schleyer-Straße 4**

**D - 47877 Willich**

Name and address of the manufacturer or the introducer of the product on the market who is established in the EC

herewith take the sole responsibility to confirm that the product:

**PRO MIXER DX100**

Type designation and, if applicable, Article-N°

which refers to this declaration, is in accordance with the following standards or standardized documents:

EN 60065

EN 61000-3-2

EN 55020

EN 61000-3-3

EN 55013

The following operation conditions and installation arrangements have to be presumed:

**acc. to Operating Manual**

**BEHRINGER**  
INTERNATIONAL GmbH  
Hanns-Martin-Schleyer-Str. 36-38  
D-47877 Willich, Mercurstraße II  
Tel.-Nr. 0 21 54 / 92 06-0  
Fax-Nr. 0 21 54 / 92 06-30

**B. Nier, President**

**Willich, 01.07.1998**

Name, address, date and legally binding signature of the person responsible

# SAFETY INSTRUCTIONS

**CAUTION:** To reduce the risk of electrical shock, do not remove the cover (or back). No user serviceable parts inside; refer servicing to qualified personnel.



**WARNING:** To reduce the risk of fire or electrical shock, do not expose this appliance to rain or moisture.



This symbol, wherever it appears, alerts you to the presence of uninsulated dangerous voltage inside the enclosure - voltage that may be sufficient to constitute a risk of shock.



This symbol, wherever it appears, alerts you to important operating and maintenance instructions in the accompanying literature. Read the manual.

## DETAILED SAFETY INSTRUCTIONS:

All the safety and operation instructions should be read before the appliance is operated.

### **Retain Instructions:**

The safety and operating instructions should be retained for future reference.

### **Heed Warnings:**

All warnings on the appliance and in the operating instructions should be adhered to.

### **Follow instructions:**

All operation and user instructions should be followed.

### **Water and Moisture:**

The appliance should not be used near water (e.g. near a bathtub, washbowl, kitchen sink, laundry tub, in a wet basement, or near a swimming pool etc.).

### **Ventilation:**

The appliance should be situated so that its location or position does not interfere with its proper ventilation. For example, the appliance should not be situated on a bed, sofa rug, or similar surface that may block the ventilation openings: or placed in a built-in installation, such as a bookcase or cabinet that may impede the flow of air through the ventilation openings.

### **Heat:**

The appliance should be situated away from heat sources such as radiators, heat registers, stoves, or other appliance (including amplifiers) that produce heat.

### **Power Source:**

The appliance should be connected to a power supply only of the type described in the operating instructions or as marked on the appliance.

### **Grounding or Polarization:**

Precautions should be taken so that the grounding or polarization means of an appliance is not defeated.

### **Power-Cord Protection:**

Power supply cords should be routed so that they are not likely to be walked on or pinched by items placed upon or against them, paying particular attention to cords and plugs, convenience receptacles and the point where they exit from the appliance.

### **Cleaning:**

The appliance should be cleaned only as recommended by the manufacturer.

### **Non-use Periods:**

The power cord of the appliance should be unplugged from the outlet when left unused for a long period of time.

### **Object and Liquid Entry:**

Care should be taken so that objects do not fall and liquids are not spilled into the enclosure through openings.

### **Damage Requiring Service:**

The appliance should be serviced by qualified service personnel when:

- The power supply cord or the plug has been damaged; or
- Objects have fallen, or liquid has been spilled into the appliance; or
- The appliance has been exposed to rain; or
- The appliance does not appear to operate normally or exhibits a marked change in performance; or
- The appliance has been dropped, or the enclosure damaged.

### **Servicing:**

The user should not attempt to service the appliance beyond that is described in the Operating Instructions. All other servicing should be referred to qualified service personnel.



# DX100

**Professional DJ mixer with a total of 4 stereo sources on 2 dual-input channels**

- ▲ High-class microphone input with peak indicator
- ▲ High precision phono pre-amps for bass power and crystal clear sound
- ▲ Ultra-musical 3-band EQ for maximum creative power
- ▲ Ultra-low noise design comparable to studio grade consoles
- ▲ Replaceable and ultra-high quality Panasonic cross fader guarantees 200.000 lifecycles
- ▲ Large Punch buttons at the cross fader - your big plus for creative mixing!
- ▲ PFL switches with status LEDs on both channels
- ▲ A Balance control allows you to blend between Main and PFL on the phones section
- ▲ Master level control on the Main Out
- ▲ Tape outputs for parallel recording on gold-plated RCA connectors
- ▲ High precision 12-digit LED VU meters
- ▲ High-quality 60 mm Panasonic channel faders as found in professional recording consoles
- ▲ Robust external power supply ensures maximum signal integrity
- ▲ Top quality components ensure superb audio performance and maximum endurance
- ▲ Super-rugged construction ensures long life, even under the most demanding conditions
- ▲ Manufactured under the stringent ISO9000 management system

PRO  
MIXER

## FOREWORD

Dear Customer,

Welcome to the team of PRO MIXER users and thank you very much for expressing your confidence in BEHRINGER products by purchasing this unit.

It is one of my most pleasant tasks to write this letter to you, because it is the culmination of many months of hard work delivered by our engineering team to reach a very ambitious goal: presenting an outstanding mixer for flexible use in studios, clubs or at home. The task to develop our new PRO MIXER series certainly meant a great deal of responsibility, which we assumed by focusing on you, the discerning user and musician. It also meant a lot of work and night shifts to accomplish this goal. But it was fun, too. Developing a product usually brings a lot of people together, and what a great feeling it is when everybody who participated in such a project can be proud of what we've achieved.

It is our philosophy to share our joy with you, because you are the most important member of the BEHRINGER family. With your highly competent suggestions for new products you've greatly contributed to shaping our company and making it successful. In return, we guarantee you uncompromising quality (manufactured under ISO9000 certified management system) as well as excellent technical and audio properties at an extremely favorable price. All of this will enable you to fully unfold your creativity without being hampered by budget constraints.

We are often asked how we can make it to produce such high-grade devices at such unbelievably low prices. The answer is quite simple: it's you, our customers! Many satisfied customers means large sales volumes enabling us to get better conditions of purchase for components, etc. Isn't it only fair to pass this benefit back to you? Because we know that your success is our success, too!

I would like to thank all people whose help on "Project DX100" has made it all possible. Everybody has made very personal contributions, starting from the designers of the unit via the many staff members in our company to you, the user of BEHRINGER products.

My friends, it's been worth the trouble!

Thank you very much,

A handwritten signature in black ink, appearing to read 'U. Behringer', with a long horizontal flourish extending to the right.

Uli Behringer



# TABLE OF CONTENT

<b>1. THE MANUAL</b> .....	<b>7</b>
1.1 Nomenclature .....	7
<b>2. DX100 OVERVIEW</b> .....	<b>7</b>
2.1 Highly accurate Main / PFL Peak - reading bargraph meters .....	8
2.2 How will YOU use YOUR DX100? .....	8
2.3 PSU (Power Supply Unit) .....	8
2.4 Warranty .....	8
2.5 Packing .....	8
<b>3. INPUT CHANNEL 1 AND 2</b> .....	<b>8</b>
3.1 Input selection .....	8
3.2 Input gain .....	9
3.3 Output level .....	9
<b>4. DJ MIC CHANNEL</b> .....	<b>9</b>
<b>5. OUTPUT SECTION</b> .....	<b>9</b>
5.1 Cross fader .....	9
5.2 Transforming with punch .....	9
5.3 Equalizer .....	10
5.4 Outputs .....	10
<b>6. HEADPHONES, MONITORS &amp; PFL</b> .....	<b>11</b>
6.1 PFL : Pre-Fader listening .....	11
6.2 Headphones - read carefully! .....	11
<b>7. CONNECTIONS</b> .....	<b>11</b>
7.1 PRO MIXER DX100 connections .....	11
7.2 Plug soldering guide .....	12
<b>8. GLOSSARY</b> .....	<b>13</b>
<b>9. SPECIFICATIONS</b> .....	<b>16</b>
<b>10. WARRANTY</b> .....	<b>17</b>

# 1. THE MANUAL

We know that reading manuals can be a bore, and that you are probably impatient to get started with your new DX100 mixer, if you haven't already! It is true that with a modicum of knowledge about audio equipment you could get up and running successfully, but chances are you will not be able to exploit the full potential of your DX100 (or yourself) until you have some of its more advanced features explained. Please, please at least read through all the text in this section, which contains important safety tips to help preserve you and your valuable equipment.

 **You'll get nowhere with your DX100 unless it is properly connected to your music sources, power amplifiers, tape recorder etc. We strongly advise that you never use cheap connecting plugs for audio - use only gold-plated ones, as these are best at resisting corrosion. Run any mics on balanced lines to minimize unwanted interference, and check those mains plugs for loose cable clamps or electrical contacts frequently.**

Good quality plugs are extremely important, all the more so where connections are left untouched for long periods. (Unplugging leads frequently can help to keep contacts clean by mechanical abrasion). Also moisture in a humid nightclub greatly accelerates the build-up of oxide (e.g. rust) on metal contacts. For the complete wiring scheme for all inputs and outputs please refer to **chapter 7 CONNECTIONS**.

 **Never patch line level devices into your highly sensitive phono inputs. Phono cartridge output is measured in millivolts. CD and tape players are of the order of magnitude of a volt. With line levels you are looking at signals 100 times more powerful than a phono pre-amplifier is designed to handle!**

 **Please always ensure that the mixer power supply is securely connected to the mixer before you turn on the mains supply. Power amps should always be turned on last of all in order to minimize switch-on thumps, which can easily damage loudspeakers. Check that there is no signal going through the DX100 when the amps are switched on in order to avoid any sudden volume surges. It is best to turn down all output faders and rotary controls first.**

## 1.1 Nomenclature

This manual is a combination of figures and text. Together these precisely define and describe all the functions of your DX100. For reasons of clarity you might find certain text or subject matter appears more than once in the manual. This means we pay a little more in printing and publishing costs, but it does mean that each section is self-contained and therefore easier for you to read.

Sometimes technical information is provided in brackets. Don't worry - you don't need to know what the figures mean in order to have success with your DX100. This info is included for the benefit of sound engineers, not DJ's! The manual is also crammed full of creative ideas on how to play your DX100 to full advantage. Try to read it from cover to cover at least once. Otherwise you'll never know what possibilities you might be missing out on!

 **The following operational manual will introduce you to the BEHRINGER PRO MIXER DX100 and its various functions. After reading the manual carefully, make sure it is always on hand for future reference.**

## 2. DX100 OVERVIEW

The DX100 is a professional-quality stereo mixer designed for all applications where pre-recorded music is mixed and played. It is equally at home, in dance clubs and personal DJ setups. It has two stereo music channels which are routed to opposite ends of a super-smooth cross fader. A DJ mic signal is then added to the music output from the cross fader to give the final mix output.

## 2.1 Highly accurate Main / PFL Peak - reading bargraph meters

Both music channels have highly-accurate PFL (Pre-Fader-Listen) [3]. This means that you can see (on the bargraph meters [11]) and hear (on headphones) the music you are about to play without disturbing the main mix - essential if you want to come in at the same level and in time with the music currently playing. (All professional DJ's strive to do this, often overlapping two tracks, or slowly cross fading between them. These and other DJ mixing tricks will be explained elsewhere in this manual.)

## 2.2 How will YOU use YOUR DX100?

Your DX100 is a **musical instrument** offering you many creative mixing possibilities with its clean, ultra DJ-friendly control surface. Learn to play it well. If possible, experiment with it "off-line" - before you use it in a performance.

## 2.3 PSU (Power Supply Unit)

Any amplifier circuit is limited in its transient response by the available current. Every mixer has numerous line level operational amplifiers (op-amps) inside. When being driven hard, many desks begin to show signs of stress due to power supply limitations. Not so with the PRO MIXER DX100. The sound will always stay clean and crisp right up to the operating limits of the op-amps themselves, thanks to our generous 20 W external power supply unit.

Please connect the PSU with the PRO MIXER DX100 PSU connector [24] on the rear panel of your mixer and switch on your DX100 with the power switch [23].

 **Do not connect the PSU to the PRO MIXER while the PSU is connected to the mains supply. Connect switched-off desk and PSU first before you connect the PSU to the mains supply.**

## 2.4 Warranty

Please take time to have the warranty card filled out completely by your specialized dealer and return it within 14 days after the date of purchase, so as to be entitled to benefit from our extended warranty. You will find the serial number [25] of your DX100 on the rear panel.

## 2.5 Packing

Your BEHRINGER PRO MIXER DX100 was carefully packed in the factory and the packaging was designed to protect the unit from rough handling. Nevertheless, we recommend that you carefully examine the packaging and its contents for any signs of physical damage, which may have occurred in transit.

 **If the unit is damaged, please do not return it to us, but notify your dealer and the shipping company immediately, otherwise claims for damage or replacement may not be granted. Shipping claims must be made by the consignee.**

# 3. INPUT CHANNEL 1 AND 2

Plug a phono (turntable) or line source (CD player etc.) into the appropriate PHONO [19] or LINE [20] input. Play music at a typical volume to check out and set up the channel.

## 3.1 Input selection

Stereo inputs [19] and [20] are on the back panel. Your source is selectable between PHONO and LINE by the toggle switch [1] immediately above the channel fader.

 **Never patch line level devices into your highly sensitive phono inputs. Phono cartridge output is measured in millivolts. Line level signals are of the order of magnitude of a volt. With line levels you are looking at a signal up to 100 times more powerful than the phono pre-amplifier is designed to handle!**

 **If for some reason your turntable has a built-in RIAA pre-amp, you should patch it into a line level input.**

## 3.2 Input gain

When you select PHONO or LINE your DX100 input channel's gain structure is automatically switched to exactly match the output from a typical phono cartridge (turntable) or line level device (CD/cassette/DAT player etc.). If your music source has an output level or volume control you can set this level exactly, using the channel PFL button [\[3\]](#) to send the input signal to the main meters. Pre-Fader Listen is the professional way to check input levels. A control LED [\[4\]](#) lights when the PFL function is enabled.

 **Normally you will want to PFL only one channel at a time.**

## 3.3 Output level

Channel output level is controlled by a precision stereo 60 mm fader [\[2\]](#).

 **The faders used are ultra-high quality true-log faders made by Panasonic. These give ultra-smooth operation even at low levels, on a par with those used in the most expensive studio consoles.**

## 4. DJ MIC CHANNEL

Plug a dynamic microphone into the jack DJ MIC input [\[17\]](#) on the front panel left.

 **The mic pre-amp is of the same quality as our award-winning EURODESK range. This gives an incredibly warm, clear and noiseless performance. Mic input is via a balanced jack connector. (Balanced operation gives best noise performance.)**

There is no PFL switch for the DJ MIC - simply stop the music and set DJ MIC level [\[5\]](#) (top left, top panel) while observing the high-precision bargraph meters. A latching switch MIC ON [\[8\]](#) activates the mic channel, while the PEAK LED [\[9\]](#) immediately to the right lets you know if DJ MIC level is set too high.

## 5. OUTPUT SECTION

### 5.1 Cross fader

Channels 1 and 2 go to opposing ends of the modestly-legended ULTRA-HIGH QUALITY FADER [\[12\]](#). When set fully to the left, only channel 1 is heard in the mix, and vice versa. We know how much you will rely on this cross fader for mixing. For this reason we have ensured that it is incredibly durable and smooth-acting.

 **The cross fader is of a extremely high quality. Its Panasonic monorail design means that you can expect a massive 200,000 smooth operations before wear & tear even becomes a factor.**

### 5.2 Transforming with punch

Transforming is a DJ term used to describe the inserting of a piece of music rhythmically into another piece. When the cross fader is to one side of the middle pushing the punch button on the opposite side will bring up



the level of that side of the cross fader. This way it is possible to punch in a piece of music, typically a certain drum track or lyric, into the playing piece of music. Traditionally this is done by rapidly pushing the fader up from minus infinity to 0 or +6 dB or moving a cross fader from one side to the middle to give a stuttering or 'gated' effect. These methods are still valid, but if you are looking for instantaneous transforming check out our ergonomic alternative - a pair of big PUNCH buttons [10], operating on channels 2 and 3. We are sure you will grow to love their speed and ease of operation.

 **The big PUNCH buttons on the DX100 are designed to get a quick control. At this point it's worth pointing out that all the smaller switches on your DX100 are latching. This means they stay down until you hit them again. PUNCH buttons are non-latching, or momentary in operation. This means that they are only active when your finger (or other appendage) is actually holding them down, like the keys on a MIDI keyboard. These are ideal for executing transformations, as you will very quickly find as you get into using your DX100.**

 **Try running a rhythm track through channel 1 (cross fader fully to the left). Now use the channel 2 PUNCH button to manually chop in a sustained signal like orchestral music, ambient sounds, noise, whatever.**

### 5.3 Equalizer

Master EQ comprises three control knobs which enable cut and boost of TREBLE [14], MID [15] and BASS [16] frequencies respectively (see below for specs.) EQ can sweeten or effect the mix, with the fading out and in of frequency bands being very popular.

Control	EQ	Frequency	Gain	OFF position
Treble	Shelving	10 kHz	+/- 12 dB	Centre
Mid	Peaking	700 Hz	+/- 8 dB	Centre
Bass	Shelving	50 Hz	+/- 12 dB	Centre

Tab. 5.1: EQ section of your DX100

 **The EQ can have a great influence. It can enhance or ruin your sound. The EQ is particularly useful if you use both sides of the centre position.**

### 5.4 Outputs

Stereo outputs include MAIN [21] and TAPE [22] (see **chapter 7 CONNECTIONS**). Level to these outputs is controlled by the rotary control MAIN OUT [13], top right on the top panel. MAIN OUT level is displayed on the bargraph meters [11] unless PFL is engaged.

 **Watch the output meters! Remember - distortion is not volume, and any distortion introduced before the power amplifiers and speakers will worsen your sound and cause amps and speakers to clip sooner.**

MAIN would normally feed the main PA system (or Hi-Fi amp if you are mixing at home). The TAPE stereo output is primarily for recording, but it could also be used for feeding the mix into a separate sound system, such as DJ foldback or another room or area in a dance club.

## 6. HEADPHONES, MONITORS & PFL

### 6.1 PFL : Pre-Fader listening

When any PFL button **[3]** is depressed the main meters will change to displaying PFL level. PFL is the way to hear, cue and set up a piece of music before you play it out in the mix.



**In the club environment, things get messy. You can't hear any sound in isolation, either on a foldback system or headphones, because both are to some extent drowned out by the main PA system. You should, however, be able to hear the PFL signal loud enough to detect the beat, cue starts etc. What you can't do is to judge by ear exactly what level the next track will come in at. For that you must use your eyes, and the highly-accurate bargraph VU meters.**

PFL is also used to accurately check input GAIN. With a channel's PFL button engaged (DOWN) you can accurately measure the input GAIN by making a typical noise or playing a typical piece of music and observing the main VU meters.



**If you are in the habit of slamming the channel faders all the way up (+6 dB), try to keep your MAIN OUT control at a compensatory -6 dB to make sure you don't risk distortion. To do this first set up output section EQ to suit the room or yourself. Now successively engage and disengage PFL on the channel currently playing, all other channels silent. Adjust MAIN OUT until the PFL and MAIN meter readings are identical. With channel faders at +6 dB and main output level at -6 dB your DX100 has unity gain from input to output. Now PFL and MAIN metering should show the same level, allowing direct visual comparison between outgoing (playing) and incoming (cue) tracks.**



**If you re-adjust output EQ the above will no longer be true : re-set MAIN OUT level as described in the paragraph above !**

### 6.2 Headphones - read carefully!

The PHONES section lies to the far left hand side of the DX100, below the DJ MIC level control. (The PHONES TRS socket **[18]** is on the front panel right.) PHONES **[6]** controls headphones output level. Right, that's the easy bit explained. Now pay attention. BALANCE **[7]** controls the blend of the PFL and MAIN mix signals. This gives you the interesting possibility of hearing both the outgoing (MAIN) and incoming (PFL) tracks simultaneously through a single output, via your headphones.

## 7. CONNECTIONS

### 7.1 PRO MIXER DX100 connections

Follow us on a walk along the case of your PRO MIXER:

- [17] Mic input.** 1/4" jack socket, tip = hot (+ve), ring = cold (-ve) and sleeve = ground/screen.
- [18] Phones.** 1/4" jack socket, tip = left signal, ring = right signal and sleeve = ground/screen.
- [19] Phono inputs.** RCA sockets.
- [20] Line inputs.** RCA sockets.
- [21] Main outputs.** RCA sockets.
- [22] Tape outputs.** RCA sockets.



**Please ensure that only qualified persons install and operate the PRO MIXER DX100. During installation and operation the user must have sufficient electrical contact to earth. Electrostatic charges might affect the operation of the PRO MIXER DX100!**



## 7.2 Plug soldering guide

You will need a lot of cables for different purposes - see the following figures to make sure you have got the right ones.

Use custom-made RCA cables for all connections which use RCA sockets (centre post = signal (+ve) and sleeve = ground/screen).

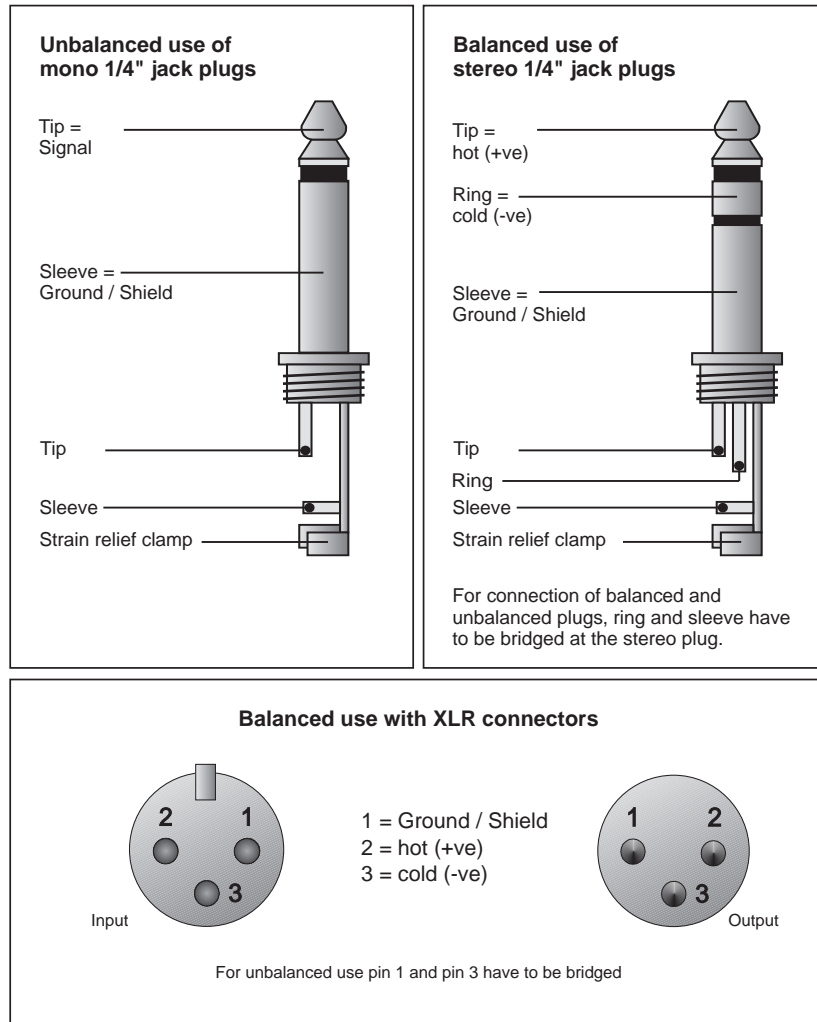

Fig. 7.1: Un-/balanced jack plugs and balanced XLR connectors

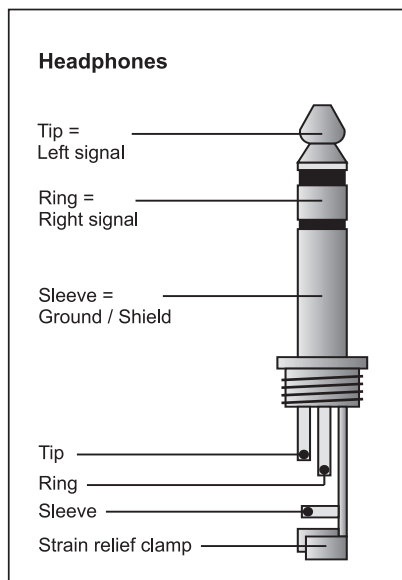

Fig. 7.2: Headphones connector

## 8. GLOSSARY

### **Ambient Music**

atmospheric/lacking in a strong beat (e.g. can be played with a drum track, can be rhythmically gated etc.)

### **Balance**

relative levels of left/right in a stereo pair, usually controlled by a panoramic potentiometer (panpot)

### **BPM**

Beats Per Minute

### **Channel**

input strip on a mixing desk

### **Clip, Clipping**

overload, severe distortion

### **Compressor**

device or program for limiting dynamic range (increasing energy)

### **Cross fader**

fades in one music track while simultaneously fading out another

### **Cue**

headphone feed

### **Cueing**

getting music ready to come in at pre-arranged point

### **Cut Switch**

silences audio

### **dB (decibel)**

a unit of measurement, ratio of two voltages ( $\text{dB} = 20 \log (V1/V2)$ ), (dBu = voltage ratio relative to 0.775 V RMS)

### **DI (Direct Injection)**

connecting an electric instrument directly to the console via a DI-Box, converting the high level unbalanced signal (from the instrument) into a low level balanced signal (for the console)

### **DJing**

sequencing music tracks e.g. for dancing audience

### **Drum machine**

electronic drum instrument

### **Echo**

device or program for adding repeats

### **Effects (abbr. FX or EFX)**

devices that alter the original ('dry') sound or add something to it, e.g. delay

**Equalizing**

the use of filters for cutting or boosting selected frequencies

**Exciter/Enhancer**

device or program for improving treble and bass intelligibility

**Expander**

(see Noise Gate)

**Fader**

linear potentiometer with logarithmic response

**Feedback (howlround)**

unstable circuit (e.g. mic/speaker, input/output) where a signal is able to return to an input from an output, causing successive cycles of progressively higher gain (avoid it by e.g. not using a mic close to a speaker driven from the mic's own signal)

**Filter**

device or program for adding or removing removing part of frequency bandwidth e.g. for dramatic effect

**Flanger/Chorus**

device or program for adding short modulated echoes

**Gain**

degree of amplification

**Headroom**

signal range between nominal level and clipping

**Incoming (cue) track**

music being auditioned prior to being played

**Kill Switches**

switches for removing frequency bands

**Limiter**

(see Compressor)

**Line level signals**

signals from low impedance sources (-10 to +6 dBu)

**Lo(w) Cut (= High Pass) Filter**

cuts off low frequencies

**MCing**

adding dialog to a sequence of music

**MIDI**

Musical Instrument Digital Interface - the language used by 99% of all electronic musical devices and programs

**Mixdown**

process by which a multitrack recording is combined into e.g. one or two channels

**Mixing**

sequing music to form continuous flow

**Mute**

(to engage) button for signal muting

**Mute Switch**

(see Cut Switch)

**Noise Gate**

device or program for auto-muting

**Normal**

connect an output to an input via breakable link

**Outgoing (mix) track**

music currently playing

**Parametric EQ**

EQ whose frequency can be swept e.g. for dramatic effect

**PFL**

Pre-Fader-Listen

**Phantom Power**

+48 V DC voltage for powering condenser mics

**Phase coherence**

degree to which L & R signal are synchronized

**Phase correlation**

degree of mono compatibility of L & R signal

**Pot or potentiometer**

a variable, usually rotary voltage driver used e.g. for gain, frequency, quality or bandwidth control

**Rapping**

adding dialog to a rhythmic track

**Recorder**

device or program for recording and playing back sounds (e.g. tape, hard disk)

**Regeneration**

(see Feedback)

**Resonance**

fast feedback

**Reverb**

device or program for adding reverb

**Route**

signal path

**RPM**

Revolutions Per Minute

**Sampler**

device for digitally storing and playing back sound

**Scratching**

manually spinning vinyl discs e.g. backwards and forwards

**Sequencer**

device or program for recording and playing back compositions (see MIDI)

**Slipmat**

Fabric turntable mat which enables turntable to spin while DJ holds record stationary. Let go record for a fast start. Gets over problems of slow turntable start.

**Solo**

solo in place, stereo image retained

**Source**

signal source

**Spatial Enhancer**

psychoacoustic device or program for making stereo seem to come from beyond the area between the loudspeakers

**Synthesizer**

electronic musical instrument

**Tempo**

(see BPM)

**Transforming**

chopping up a music signal by using mutes or gates etc.

**Transient**

a transitory (extreme) rise in signal level

**Trimpot**

variable gain potentiometer

**Varispeed**

control for varying playback speed

**Wet signal**

mix signal with effects added

## 9. SPECIFICATIONS

### INPUT CHANNELS

Mic input	Electronically balanced, discrete input configuration
Gain	+20 to +40 dB
Frequency response	10 Hz to 40 kHz, +/- 3 dB
THD	0.004 % typ. @ -30 dBu, 1 kHz
S/N ratio	115 dB
Phono/line	unbalanced input
Frequency response	
Line	10 Hz to 80 kHz, +/- 3 dB
Phono	20 Hz to 20 kHz, RIAA
THD	
Line	0.006 % typ. @ +4 dBu, 1 kHz, Gain 1
Phono	0.023 % typ. @ -30 dBu, 1 kHz
S/N ratio	
Line	105 dB
Phono	87 dB
Crosstalk	
Line	-78 dB
Phono	-77 dB
EQ	
Low	50 Hz, +/- 12 dB
Mid	700 Hz, +/- 8 dB
High	10 kHz, +/- 12 dB

### CONNECTORS

Main out	0 dB
Tape out	0 dB

### POWER SUPPLY

Mains Voltages	USA/Canada	~ 120 V AC, 60 Hz, PSU MXUL 2
	U.K./Australia	~ 240 V AC, 50 Hz, PSU MXEU 2
	Europe	~ 230 V AC, 50 Hz, PSU MXEU 2
	General Export Model	~ 100-120 V AC, ~ 200-240 V AC, 50-60 Hz
Power supply unit		
Model MXEU2	In: 230 VAC / 50 Hz (100 mA)	
	Out: 2 * 18.5 VAC (500 mA)	
Model MXUL2	In: 115 VAC / 60 Hz (200 mA)	
	Out: 2 * 18.5 VAC (500 mA)	

### PHYSICAL

Dimension (approx.)	8" (203 mm) * 10" (254 mm) * 2.75" (70 mm)
Net weight (without PSU)	1.7 kg

BEHRINGER is constantly striving to maintain the highest professional standards. As a result of these efforts, modifications may be made from time to time to existing products without prior notice. Specifications and appearance may differ from those listed or shown.

## 10. WARRANTY

### § 1 WARRANTY CARD

To be protected by this warranty, the buyer must complete and return the enclosed warranty card (signed/stamped by retail dealer) within 14 days of the date of purchase to BEHRINGER INTERNATIONAL (address see § 3). Failure to return the card in due time (date as per postmark) will void any extended warranty claims.

### § 2 WARRANTY

1. BEHRINGER INTERNATIONAL warrants the mechanical and electronic components of this product to be free of defects in material and workmanship for a period of one (1) year from the original date of purchase, in accordance with the warranty regulations described below. If any defects occur within the specified warranty period that are not caused by normal wear or inappropriate use, BEHRINGER INTERNATIONAL shall, at its sole discretion, either repair or replace the product.

2. If the warranty claim proves to be justified, the product will be returned freight prepaid by BEHRINGER INTERNATIONAL within Germany. Outside of Germany, the product will be returned at the buyer's expense.

3. Warranty claims other than those indicated above are expressly excluded.

### § 3 RETURN AUTHORIZATION NUMBER

1. To obtain warranty service, the buyer must call BEHRINGER INTERNATIONAL during normal business hours BEFORE returning the product (Tel.: +49 (0) 21 54 / 92 06 66). All inquiries must be accompanied by a description of the problem. BEHRINGER INTERNATIONAL will then issue a return authorization number.

2. The product must be returned in its original shipping carton, together with the return authorization number, to the following address:

**BEHRINGER INTERNATIONAL GmbH**  
**Service Department**  
**Hanns-Martin-Schleyer-Str. 36-38**  
**D - 47877 Willich-Münchheide**

3. Shipments without freight prepaid will not be accepted.

### § 4 WARRANTY REGULATIONS

1. Warranty services will be furnished only if the product is accompanied by an original retail dealer's invoice. Any product deemed eligible for repair or replacement by BEHRINGER INTERNATIONAL under the terms of this warranty will be repaired or replaced within 30 days of receipt of the product at BEHRINGER INTERNATIONAL.

2. If the product needs to be modified or adapted in order to comply with applicable technical or safety standards on a national or local level, in any country which is not the country for which the product was originally developed and manufactured, this modification/adaptation shall not be considered a defect in materials or workman-

ship. The warranty does not cover any such modification/adaptation, irrespective of whether it was carried out properly or not. Under the terms of this warranty, BEHRINGER INTERNATIONAL shall not be held responsible for any cost resulting from such a modification/adaptation.

3. Free inspections, maintenance/repair work and replacement of parts are expressly excluded from this warranty, in particular if caused by inappropriate use. Likewise, the warranty does not cover defects of expendable parts caused by normal wear of the product. Expendable parts are typically faders, potentiometers, switches and similar components.

4. Damages/defects caused by the following conditions are not covered by this warranty:

- ▲ misuse, neglect or failure to operate the unit in compliance with the instructions given in the user or service manuals.
- ▲ connection or operation of the unit in any way that does not comply with the technical or safety regulations applicable in the country where the product is used.
- ▲ damages/defects that are caused by force majeure or by any other condition beyond the control of BEHRINGER INTERNATIONAL.

5. Any repair carried out by unauthorized personnel will void the warranty.

6. Products which do not meet the terms of this warranty will be repaired exclusively at the buyer's expense. BEHRINGER INTERNATIONAL will inform the buyer of any such circumstance. If the buyer fails to submit a written repair order within 4 weeks after notification, BEHRINGER INTERNATIONAL will return the unit C.O.D. with a separate invoice for freight and packing. Such cost will also be invoiced separately when the buyer has sent in a written repair order.

### § 5 WARRANTY TRANSFERABILITY

This warranty is extended exclusively to the original buyer (customer of retail dealer) and is not transferable to anyone who may subsequently purchase this product. No other person (retail dealer, etc.) shall be entitled to give any warranty promise on behalf of BEHRINGER INTERNATIONAL.

### § 6 CLAIM FOR DAMAGES

Failure of BEHRINGER INTERNATIONAL to provide proper warranty service shall not entitle the buyer to claim (consequential) damages. In no event shall the liability of BEHRINGER INTERNATIONAL exceed the invoiced value of the product.

### § 7 OTHER WARRANTY RIGHTS

This warranty does not exclude or limit the buyer's statutory rights provided by national law, in particular, any such rights against the seller that arise from a legally effective purchase contract.

---

The information contained in this manual is subject to change without notice. No part of this manual may be reproduced or transmitted in any form or by any means, electronic or mechanical, including photocopying and recording of any kind, for any purpose, without the express written permission of BEHRINGER GmbH.

BEHRINGER is a registered trademark. ALL RIGHTS RESERVED © 1998 BEHRINGER.  
BEHRINGER INTERNATIONAL GmbH, Hanns-Martin-Schleyer-Str. 36-38, D-47877 Willich-Münchheide II  
Tel. +49 (0) 21 54 / 92 06-0, Fax +49 (0) 21 54 / 92 06-30



# Front Panel

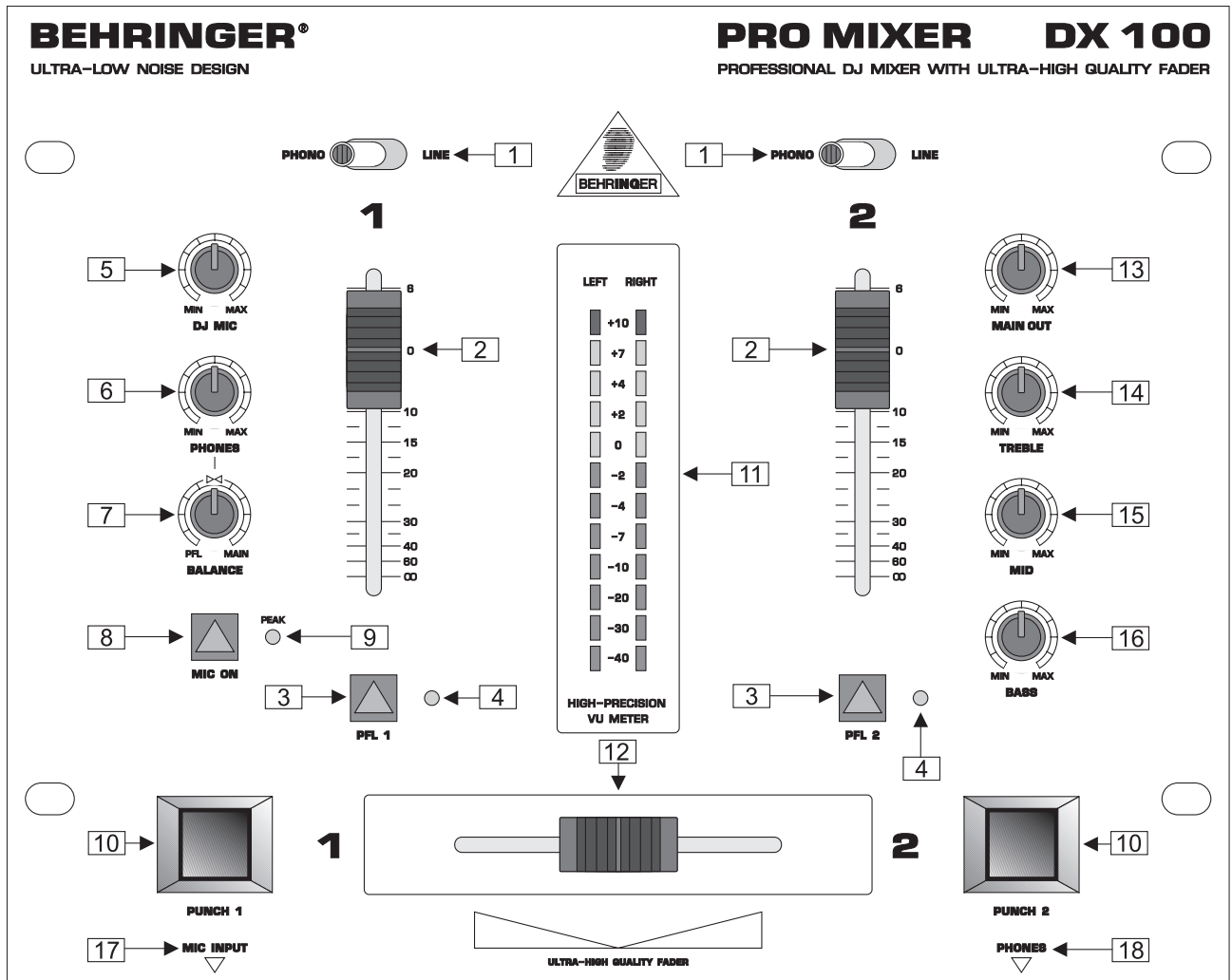

# Rear Panel

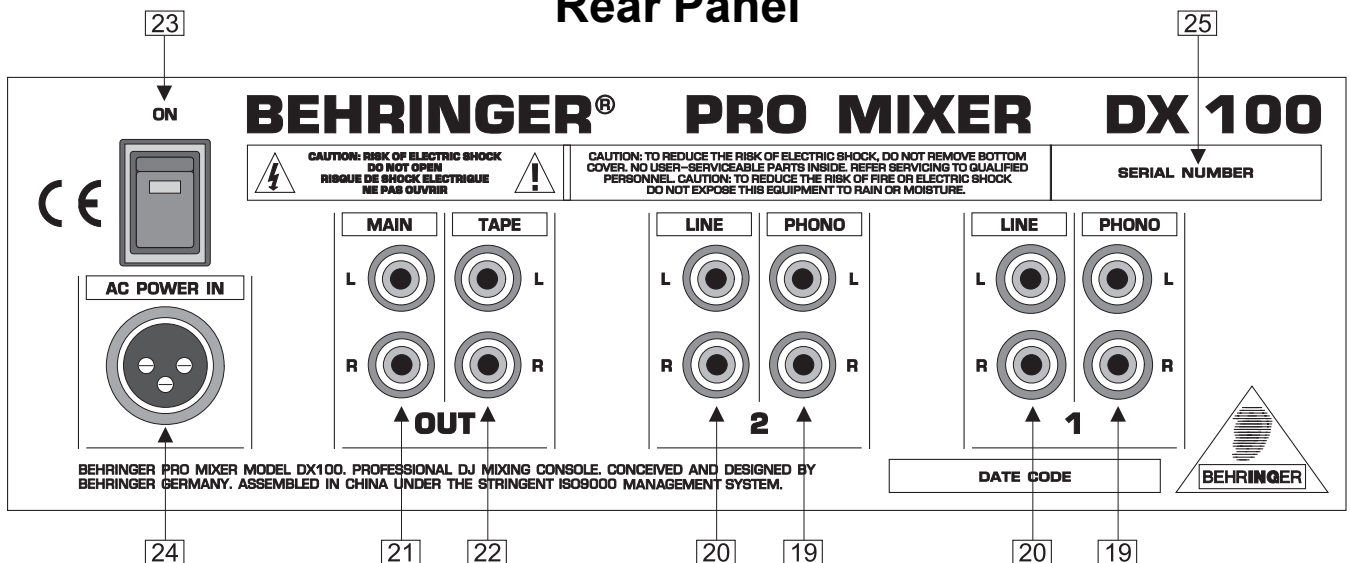

# BLOCK DIAGRAM

