

Large Format Mixers

EURODESK SX4882

**EURODESK — Ultra-low Noise Design
48/24 Input 8-Bus In-Line Mixer with
XENYX Preamps, British EQs and
Integrated Meterbridge**

- Ultra-low noise, high-headroom analog mixer for studio, live, front-of-house, monitor, corporate and touring audio applications
- True in-line concept with 24 independent Mix-B input channels, all with individual 2-band EQ, Level, Pan and Mute
- 24 state-of-the-art XENYX Mic Preamps with switchable +48 V phantom power
- Neo-classic “British” 4-band EQs with 2 semi-parametric mid bands for warm and musical sound
- 8 subgroups with independent Solo and routing functions simultaneously feed up to 16 multi-track inputs
- Clip and -20dB LEDs plus EQ In, Low Cut, Mute, Solo/PFL, Subgroup and Main routing switches on all channels
- 6 Aux sends per channel: all switchable pre/post fader
- Main Aux sends with Level controls and Solo functions
- 6 multi-functional stereo Aux returns featuring Level and Balance controls, Solo and extensive routing functions
- Solo-In-Place with PFL function plus 2 independent phones sections plus full-featured monitor and talkback section with built-in microphone



Whether recording in the studio, running live house sound, recording a live show, or for use as a stage monitor mixing board, the feature-packed SX4882 does it all. Designed with live performance versatility and recording necessities built in, this console combines years of every sound engineer's wants and needs into one high-performance machine. It may not get you free beer or groupies, but it rocks for live-sound and recording.

What is an In-Line mixer? And why you want one

An in-line mixer is a mixer within a mixer. That's the reason you will notice this board is labeled Channels 1-24 AND Channels 25 – 48. It's really two 24-channel mixers in one.

This “embedded mixer,” called Mix B, is typically used in recording applications, but it has some useful live-sound features as well. In the studio, Mix B allows you to return all your multi-track tape channels back into channels on the board without losing any of your 24 main-input channels. This provides seamless playback and mixdown capabilities with just a few button pushes and no additional patching. In other words, no visible plumber-cracks or untimely delays. Live, Mix B can be used to send a totally separate 2-track mix to a recording device, separate speaker zone or out to a broadcast feed, plus it functions as an additional monitor or effects bus.

Continued on next page



EURODESK SX4882

- Comprehensive Channel, Group and Main insert points
- Built-in meterbridge with meters for each channel, Subgroup and Main, monitoring either the channel or Tape return signal
- Long-wearing 100-mm logarithmic-taper faders and sealed rotary controls
- Expander port with universal jack connectors for optimal linking to other consoles
- 2 BNC connectors for 12 V gooseneck lights
- Internal autorange power supply for maximum flexibility (100 - 240 V~), noise-free audio, superior transient response plus low power consumption for energy saving

One reason you'll really appreciate having the in-line mixer is simple: LIVE RECORDING. If you've ever tried to make a recording off of the board during a live show, you know how well that works (NOT!). Often input and output levels necessary for quality recording do not match the requirements of the live mix, where stage volumes factor in to the overall room sound. Getting around that issue used to require a splitter and second mixer just for recording. Now that is eliminated by having an in-line mixer in your live board.

Va-Va-Va-Versatility! No More "Creative Patching"

Input choices and routing options are not overrated. In fact, they are essential to managing technically complex instrumentation or multiple bands all patched into the same board. And while you may not need every patching option for every show, at least you know you have every input and output option you could ever need. You will be grateful to have features like Insert points on every channel input, all Subgroups and on the Main outs. Direct Outputs on each channel are very useful too and may even make you a hero for about 5 minutes when you can provide a seemingly improbable solution by taking a direct split off the console to feed some other input source.

Use your creativity where it matters most – in getting the sound and mix you want, not on brain-twisting patching compromises and channel routing puzzles. Complete versatility and accessibility is what it's all about and the SX4882 does not disappoint.

All Channels Are Indeed Created Equal

There's no scrimping and saving on this board. Every channel has every feature of every other channel. They are all the same! No more "if only" sighs of frustration to utter as you try to organize your inputs. As long as we're talking about

channel strips, you might as well know that this board has a big treat in store for you: TWO bands of semi-parametric mid range controls. This is two more than many boards offer and at least one more than most live sound boards. Gone is the dilemma of EQ-ing out the honk at 600 or adding a little upper-mid crispness at 2k to bring out the clarity. Now you don't have to compromise.

British EQ for Bloody Excellent Sound

Expensive British consoles have long been praised for having sweeter, smoother channel EQ than many other mixers provide. That's why the EQ circuitry on the SX4882 is designed with British-style EQ, with wider curves and smoother phase characteristics. It maximizes effective frequency sculpting without harshness or gaping holes in the audio spectrum. This sweet feature will benefit your mixes – both live and in the studio. You may even start saying "Check One, Two" with a British accent. And it's worth repeating that there are two sweepable EQ bands, not just one. That's a must-have for many situations, and now you have it!

Mic Pre's – the muck stops here

The microphone preamp is one of the most important circuits in a mixing console. It boosts the low-level microphone signal to a line-level operating level and it's the first bit of processing applied to any mic signal. No doubt you've heard the phrase, "garbage in equals garbage out." This is really true when it comes to mic preamps. Common issues with lower quality mic pres include noise, distortion, low headroom, and unimpressed fans.

BEHRINGER uses high quality XENYX pre-amps in our professional mixers. These are ultra low noise, high headroom preamps that can hold their own, even against expensive stand-alone boutique-style preamps.

Continued on next page

EURODESK SX4882

Buttons, Buttons, Buttons

This baby's got buttons. Do buttons look cool? Yes! Is this why they are on the board? No! They're there because you need them all! But many mixers don't have all these options, which may be why some sound technicians are missing a lot of their hair.

One word of caution: You may have to contend with adoring masses asking if you really know what all those buttons do.

PFL/SOLO capability on:

- Every channel, pre- or post-fader option
- Aux bus sends
- Aux returns
- All subgroups
- Headphone mixes

Routing Matrix buttons & more:

- Select switch that assigns Mix B input OR mic/line input to Main Channel strip
- Mic/Line input select button

- Aux Send Mix B- sends Mix B input source to Aux send
- B-channel Flip switches Mix B input source to mirror main channel input
- Mix B operating input level, +4 dB or -10 db
- Channel low-cut filter
- Phantom power On, independent 8-channel blocks
- Subgroup and Main Mix assignment
- Channel mutes - on all channels 1-48, including all Mix B channels

Continued on next page

Recording Setup

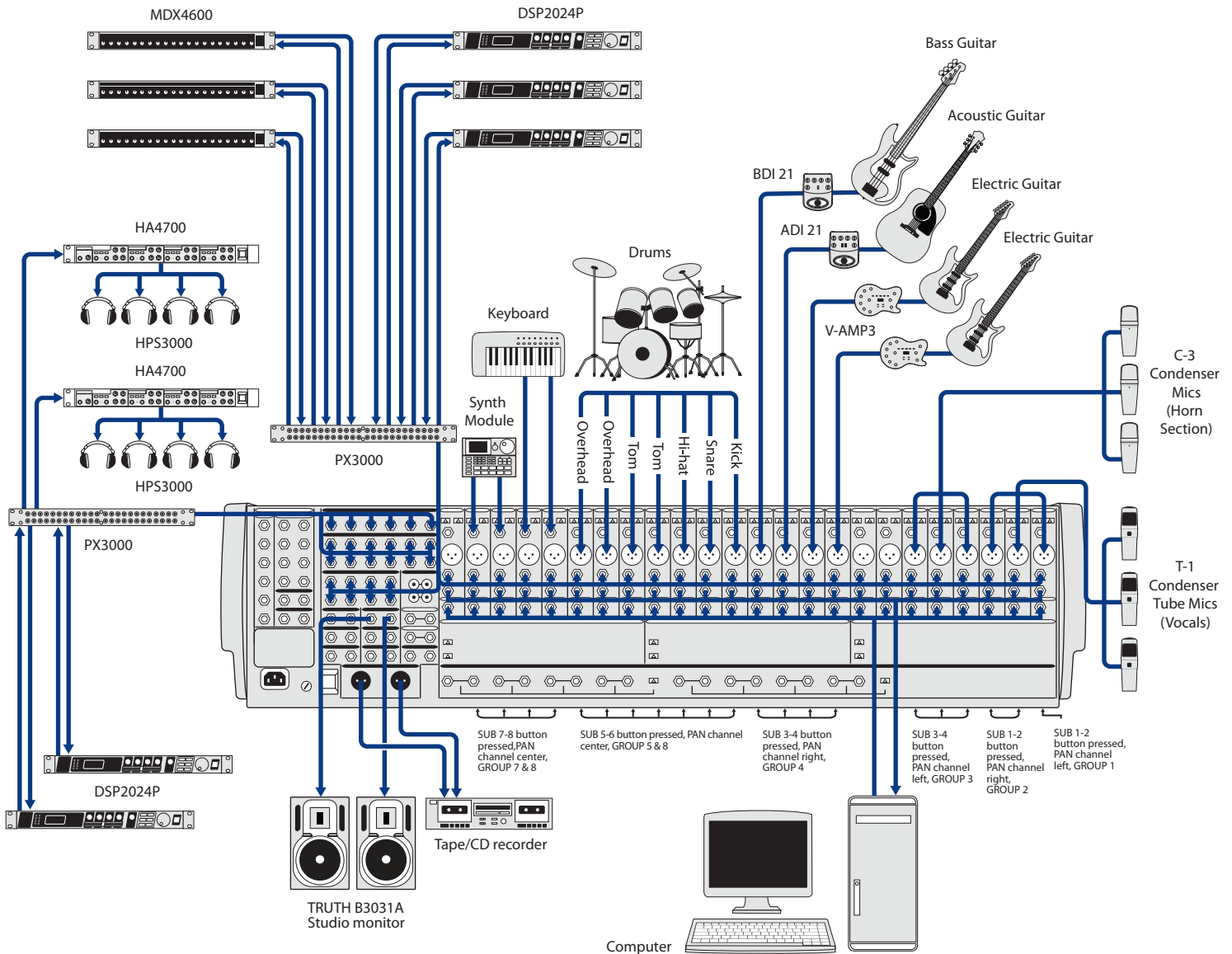

EURODESK SX4882

Octo-riffic Subgroups

Having eight Subgroups give you so much flexibility you may just become a gymnast on the side. These Subgroups can be used to send eight individual tracks directly to your tape, digital interface or hard disk recorder, or they can be used as four stereo submixes. There are two parallel outputs on each subgroup, to feed up to 16 multi-track channels.

During a live show you could use four of the subgroups for instrument and vocal sub-mixing to the PA and the other four could be for a tape sub-mix, if you choose not to use Mix B as your tape mix. For use with a stereo PA you still have 4 subgroups total to work with, and when used as a stage monitor console, the SX4882 can provide up to 16 independent monitor mixes by combining the subgroups, Aux busses, and L/R Mix B. Wicked!

In the studio, the eight Subgroups allow maximization of recording inputs by allowing several channels to be mixed down to a smaller number of recording tracks. By combining channel inputs into subgroups which go directly out to tape, you have the ability to record even more than 24 discreet inputs. Also, the outputs of the subgroups have selectable operating output levels (+4 dB or -10 dB) to match the inputs of your recording device.

Continued on next page

Live Performance Setup

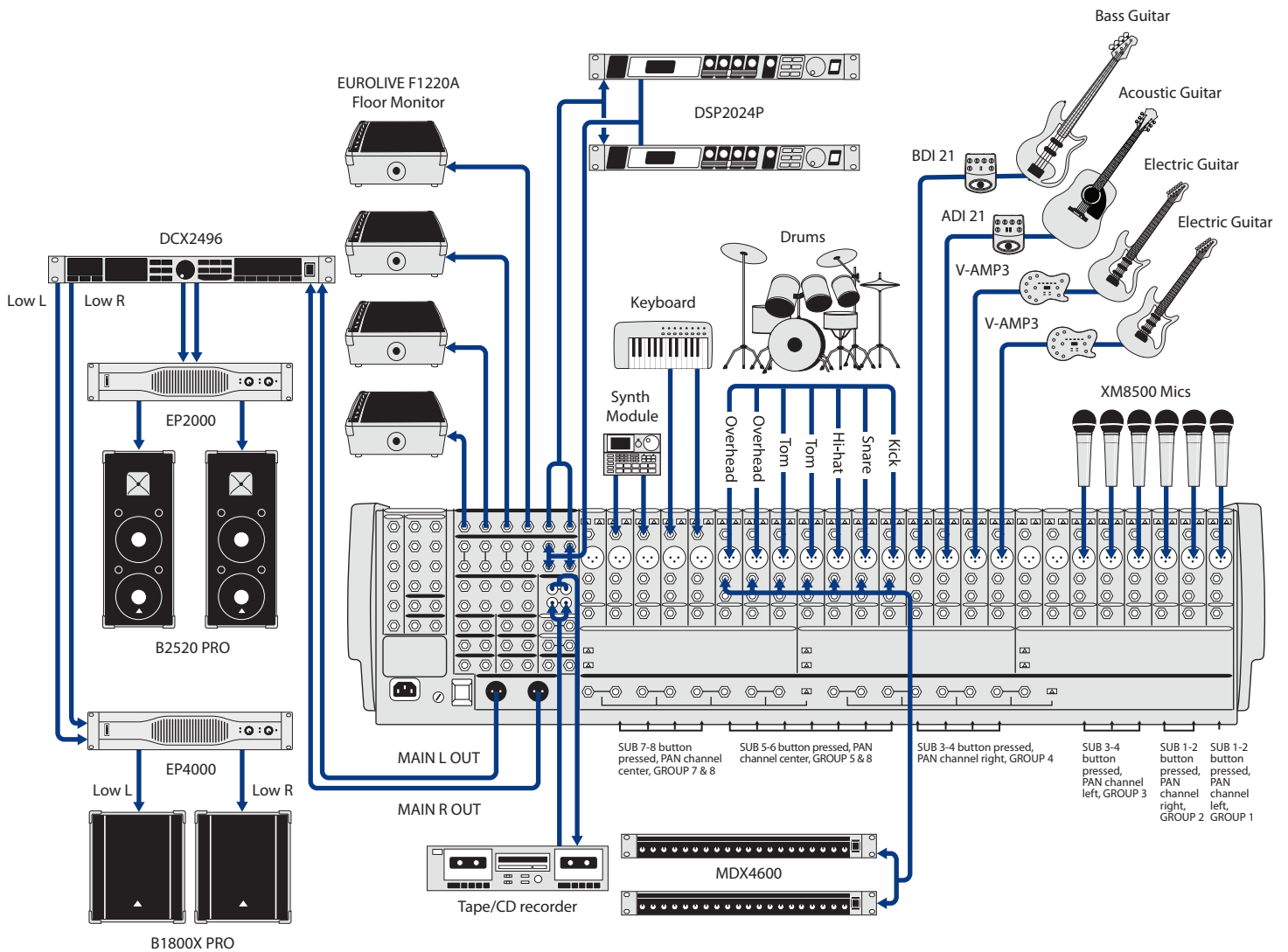

EURODESK SX4882

The Meter Bridge – Functionality and Stunningly Cool

Once you've had a meterbridge on deck, it's hard to go back. Essential in the studio and amazingly cool live, the meterbridge provides visual confirmation of what is going on with all your signals with just a quick glance. Each input channel, all the subgroups and the main outputs feature 12-level LEDs organized incrementally with traffic-light style color coding, so you can verify input and output levels, even on the Mix B channels.

Many console manufacturers offer a meterbridge only as an expensive, optional add-on, however, the SX4882 provides it standard.

APPLICATIONS

Church Services

Running live sound in houses of worship has become a truly professional pastime with the advent of affordable, quality sound gear and the rise of congregations that require bigger and more capable sound systems. The multiple input and auxiliary send options of the SX4882 are designed to accommodate a wide variety of performance needs, large and small.

Worship services, choir, and music ensembles are easily mixed and recorded live. Go directly into your digital interface from the subgroup outs, Mix B or Main Out, right into your tracking software. CD's or DVDs can then be distributed to members of the congregation who may have trouble attending services. Caution: your status may be elevated in the church from sound grunt to near-savior.

Corporate A/V

Corporate AV is a truly multi-media experience, where there may be many different input sources - from a laptop, MP3, CD, DVD, television, projector, or camera. The SX4882 has RCA tape in and two external 1/4" 2-track inputs, plus each channel has the choice of balanced or unbalanced, +4 dB or -10dB input levels. Mix B provides additional input options for routing audio sources into the console. With 48 total channels and 82 total inputs, even the largest conventions can be accommodated.

Corporate presentations often require sound reinforcement to a large room, typically with several pairs of speakers scattered throughout the auditorium. With eight subgroup outs, you have 4 sets of individual stereo controls, in addition to the main L/R out. Mix B provides an additional stereo mix, for a total of 6 separate stereo output options.

Recording Studio Features

- 8 subgroups with dual parallel outputs to drive 8 or 16 channels of a recording device or digital interface
- Mix B mixer (chs. 25-48) returns tape outputs from recording device or digital interface for immediate playback, overdub tracking, and mix down. Mix B input can be assigned to Aux mixes and studio headphone mixes, and also be assigned to Main Channel or Mix B channel with flip of button.

- 6 Stereo Aux returns - two aux returns assignable to subgroups and main mix enable Aux return signal be assigned directly to a record track. The other four returns are designed to facilitate monitoring of aux return signals and do not assign to subgroups.
- Separate control room and studio outputs, additional external 2-track monitoring, dual independent headphone outputs, capability for four headphone mixes.
- Built in talkback mic with volume control knob. Assign talkback mic to Aux 1, Aux 2, Studio, and Headphone mixes.
- Tons of soloing capability all through the master output section

Continued on next page

Back Panel Channel Inputs

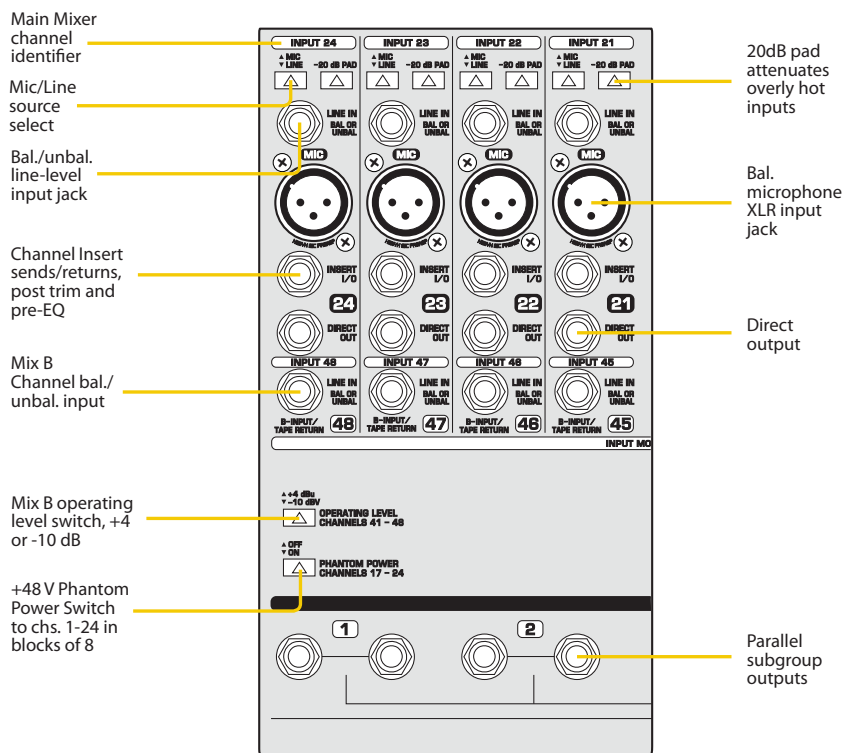

EURODESK SX4882

Live Features

- Mix B offers separate stereo mix control for recording or broadcast feeds independent from main board mix and also provides an additional Aux bus.
- 8 mono subgroups or 4 stereo pairs for enhanced mixing control.
- Full LED meterbridge for enhanced monitoring capabilities and additional "wow" factor.
- Full Solo/PFL capability throughout the console, including subgroups and Aux sends.

- 6 Auxiliary sends for monitors and effects, all with pre-post switches and selectable between main channel or Mix B inputs. Also, 6 stereo Aux returns.
- Insert points on all channels, subgroups, and main out.
- Multiple input capability to accommodate a variety of sources, including three individual Tape/2-track inputs for Tape, CDs, DVDs, and MP3 players.
- Console doubles as a discreet monitor desk capable of driving 16 independent mixes.
- Mute buttons on every channel.

But wait, there's more

- 100 mm logarithmic faders and sealed rotary pots provide smooth, responsive control action and keep the snap-crackle-and-pop out your mix and out of your mixer.
- An internal autorange variable power supply allows the console to run on voltages ranging from 100 V to 240 V which is very handy for cross-Atlantic tours or funky grange halls that typically have fluctuating power.
- 2 BNC connectors for 12 V gooseneck lights
- Rugged, road-ready all-steel chassis

Master I/O Section

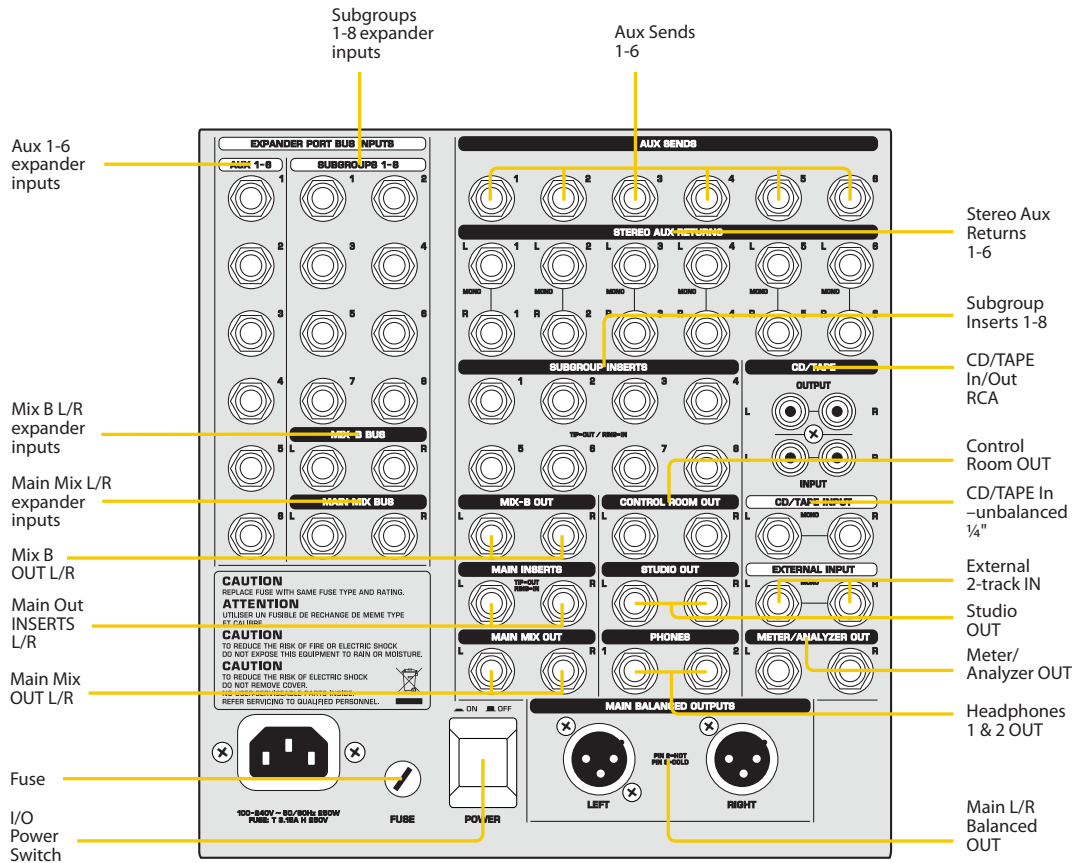

EURODESK SX4882

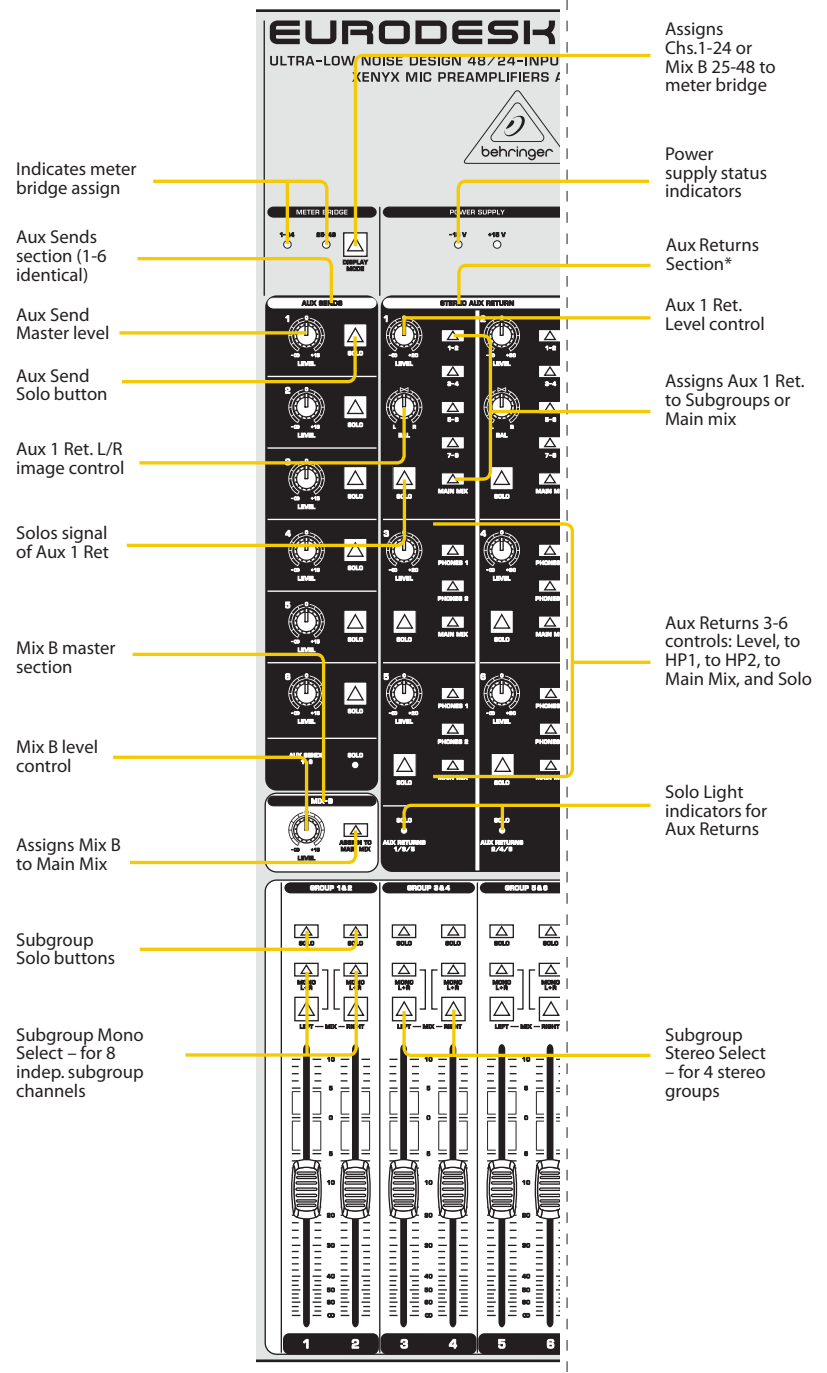
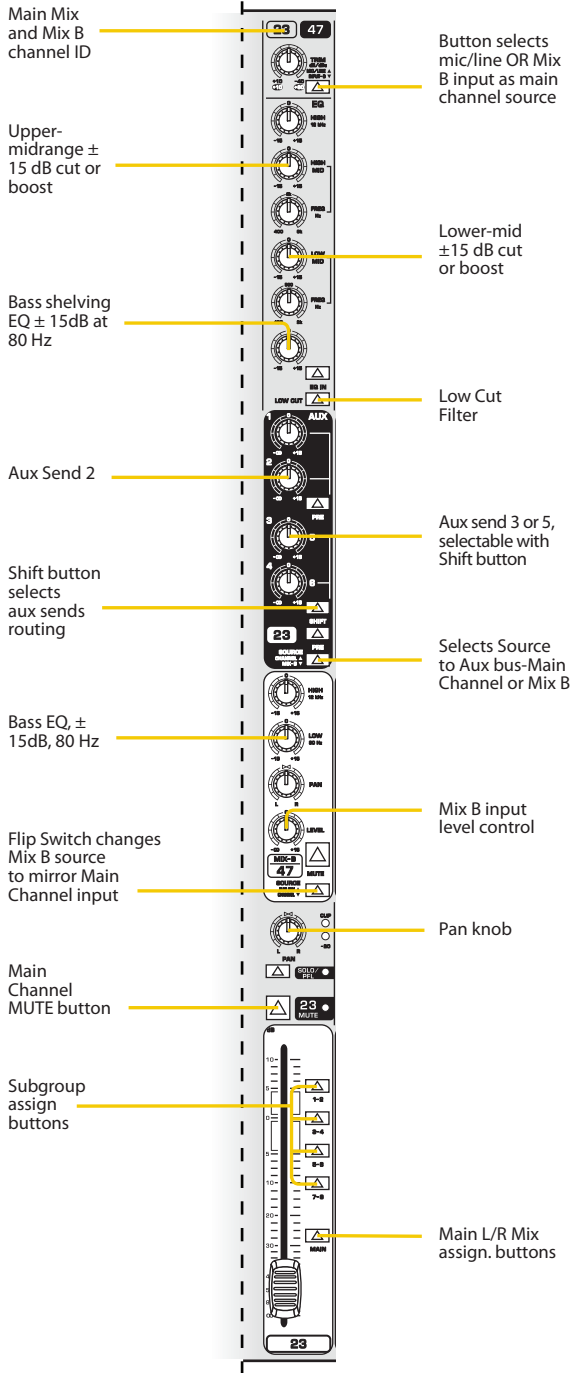

* Aux Returns 1 & 2 control sections are identical and designed to facilitate recording while Aux Rets. 3/4 and 5/6 are identical and designed to facilitate monitoring.
 ** PFL = pre-fader level and looks at input signal. Solo is post-fader and looks at output levels.

EURODESK SX4882

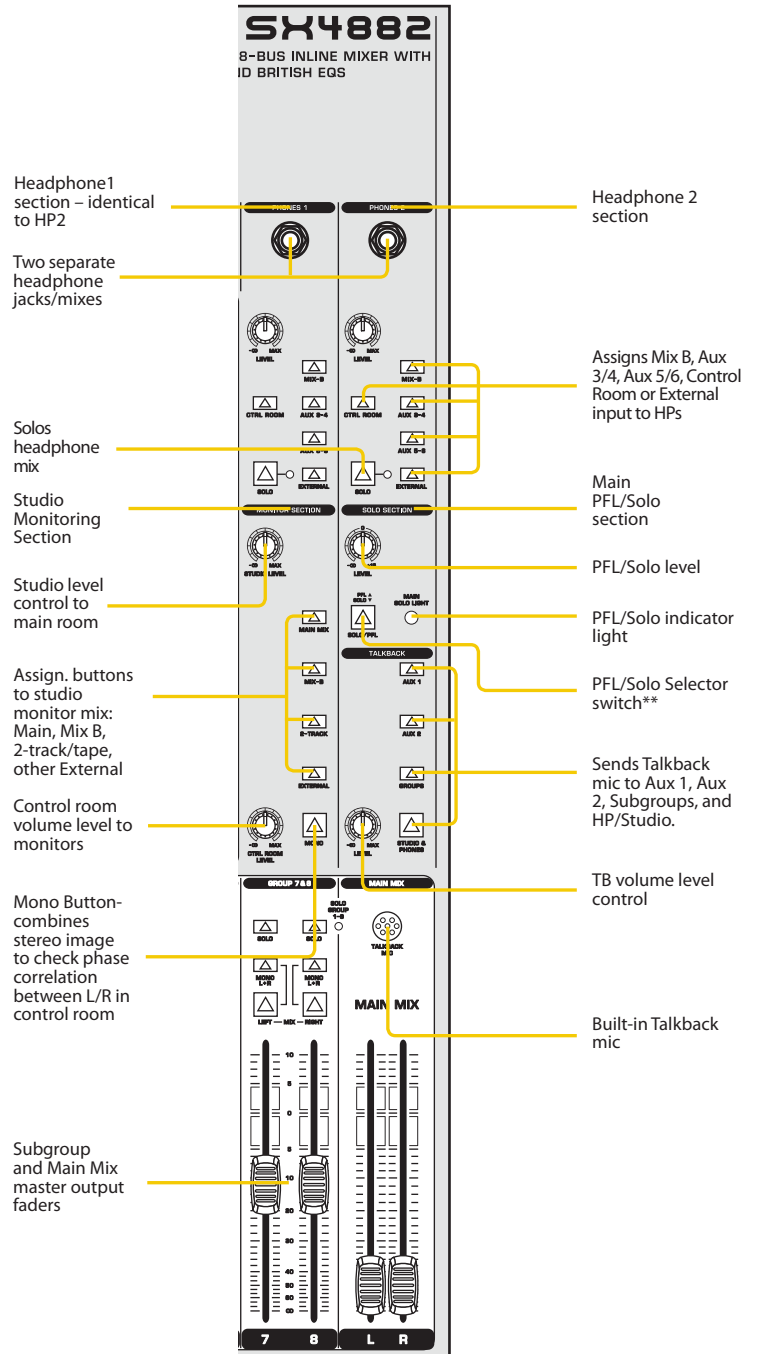
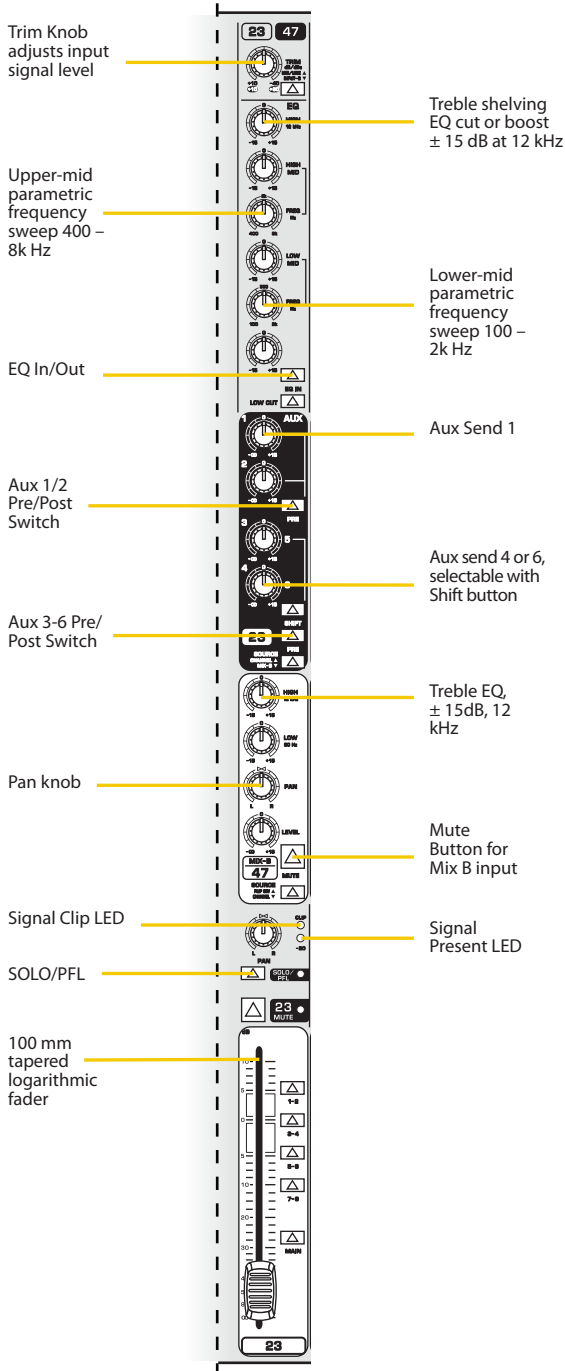

* Aux Returns 1 & 2 control sections are identical and designed to facilitate recording while Aux Rets. 3/4 and 5/6 are identical and designed to facilitate monitoring.

** PFL = pre-fader level and looks at input signal. Solo is post-fader and looks at output levels.

EURODESK SX4882

MAIN CHANNEL STRIP

Mic input

Type electronically balanced, discrete input circuit

Mic E.I.N.¹ (22 Hz - 22 kHz)

@ 150 Ω source -129.0 dBu / -117.3 dBq

Input shorted -132.0 dBu / -122.0 dBq

Distortion (THD+N) 0.007 % @ +4 dBu, 1 kHz, bandwidth 80 kHz

Gain range +10 dB to +50 dB

Max. input level +12 dBu (+32 dBu @ PAD)

Line input

Type electronically balanced

Gain range 0 dB to +40 dB (-20 dB to +20 dB @ PAD)

Max. input level +22 dBu

Channel fader range +10 dB to -85 dB / off

Aux send gain range 0 dB to +15 dB / off

Equalizer

Hi shelving 12 kHz, ±15 dB

Hi mid sweep 300 Hz to 20 kHz, ±15 dB

Lo mid sweep 50 Hz to 3 kHz, ±15 dB

Lo shelving 80 Hz, ±15 dB

Lo cut (HPF) 75 Hz, 12 dB/oct.

Channel direct out

Max. output level +22 dBu

Noise @ 0 dB gain -94 dBu

Output impedance 120 Ω

Tape returns ¼" jacks, balanced / unbalanced, globally switchable from +4 dBu to -10 dBV

Channel inserts

Max. in/out +22 dBu

Channel to channel crosstalk -95 dB @ 1 kHz

Mix B channel strip

Gain range 0 dB to +15 dB / off

Hi shelving 12 kHz, ±15 dB

Lo shelving 80 Hz, ±15 dB

SUBGROUP SECTION

Noise²

bus noise @ fader 0 dB -102.5 dB

24 chs. assigned (input B) & set @ 0 dB gain -92.5 dB

16 chs. assigned (input B) & set @ 0 dB gain -94.5 dB

Submaster output max. output level +22 dBu, balanced / unbalanced

Submaster insert max. output level +22 dBu

Submaster insert max. input level +22 dBu

Fader range +10 dB to -85 dB / off

MAIN MIX SECTION

Noise²

bus noise @fader 0 dB -101.0 dB

24 chs. assigned (input B) & set @ 0 dB gain -92.5 dB

16 chs. assigned (input B) & set @ 0 dB gain -94.5 dB

Max. output level +28 dBu, XLR connector, balanced / +22 dBu, ¼" jacks, unbalanced

Aux returns gain range 0 dB to +20 dB / off

Aux sends max. output level +22 dBu

System data

Distortion (THD+N) 0.007 % @ +4 dBu, 1 kHz, bandwidth 80 kHz; < 0.02 %, 22 Hz to 22 kHz at normal operating levels, any input to any output, bandwidth 80 kHz

Frequency response

20 Hz to 40 kHz ±1 dB (any input to any output)

10 Hz to 120 kHz ±3 dB

Noise²

@ fader 0 dB -102.5 dB

24 chs. assigned (input B) & set @ 0 dB gain -92.5 dB

16 chs. assigned (input B) & set @ 0 dB gain -94.5 dB

Power supply

Power consumption 250 W

Mains voltage 100 - 240 V~ (50/60 Hz)

Fuse T 3,15 A H 250 V

Mains connector standard IEC receptacle

Physical/weight

Dimensions (H x W x D) approx. 2.8" / 8.7 x 37 x 29.5" approx. 72 mm / 220 x 940 x 750 mm

Weight approx. 61.2 lbs / approx. 27.72 kg

1 Equivalent Input Noise

2 ref. +4 dBu

Please note these specifications are preliminary and conceptual in nature, and as such are subject to change as product development progresses. This information is supplied for market research purposes only and is not to be made public in any manner. This document is solely the property of The MUSIC Group, or one of its subsidiaries, and must be surrendered upon request of the owner.

For service, support or more information contact the BEHRINGER location nearest you:

Europe
MUSIC Group Services UK
Tel: +44 156 273 2290
Email: CARE@music-group.com

USA/Canada
MUSIC Group Services NV Inc.
Tel: +1 702 800 8290
Email: CARE@music-group.com

Japan
MUSIC Group Services JP K.K.
Tel: +81 3 6231 0454
Email: CARE@music-group.com

Technical specifications and appearances are subject to change without notice and accuracy is not guaranteed. BEHRINGER is part of the MUSIC Group (music-group.com). All trademarks are the property of their respective owners. MUSIC Group accepts no liability for any loss which may be suffered by any person who relies either wholly or in part upon any description, photograph or statement contained herein. Colors and specifications may vary from actual product. MUSIC Group products are sold through authorized fulfillers and resellers only. Fulfillers and resellers are not agents of MUSIC Group and have absolutely no authority to bind MUSIC Group by any express or implied undertaking or representation. This manual is copyrighted. No part of this manual may be reproduced or transmitted in any form or by any means, electronic or mechanical, including photocopying and recording of any kind, for any purpose, without the express written permission of MUSIC Group IP Ltd. ALL RIGHTS RESERVED. © 2012 MUSIC Group IP Ltd. Trident Chambers, Wickhams Cay, P.O. Box 146, Road Town, Tortola, British Virgin Islands. 985-10000-00384