

# Equalizers

## ULTRACURVE PRO DEQ2496



### ULTRACURVE Ultra High-Precision Digital 24-Bit/96 kHz EQ/RTA Mastering Processor

- Ultra-high resolution processor for all EQ, RTA and dynamic applications, especially for PA and audiophile mastering
- 4 concurrently selectable EQ modules (31-band graphic EQ, 10-band parametric EQ, Feedback Destroyer plus 3 Dynamic EQs per stereo channel)
- Flexible compressor/expander function with peak limiter per stereo channel as well as additional stereo imager and stereo delay for delay line applications
- Unique VPQ (Virtual Paragrophic EQ) option allows parametric control of graphic EQs
- Ultra-high resolution 61-band real-time FFT analyzer with additional auto EQ function for room and loudspeaker equalization
- Multi-functional level meters (peak/RMS, VU and SPL meter with dBA/dBC weighting via RTA/Mic input)
- 64 user memories for complete setups and/or individual module configurations
- Separate RTA mic/line input with phantom power, professional Wordclock input and MIDI connections for full remote control, preset dumps and system updates

The DEQ2496 is a high-precision digital 24-bit/96 kHz EQ/RTA mastering processor, ideal for sophisticated live sound trouble-shooting or audiophile mastering. Whether you're putting the finishing touches on recorded material or creating an optimal live sound for a multi-way PA, the DEQ2496 is built to provide meticulous control.

Equalization? Dynamics? Feedback correction? Yes, yes, yes. You can have it all with the DEQ2496. Automatic FFT analysis with Auto EQ? We added that too.

The DEQ2496 is a whole rack of flexible equalization, dynamics and time correction functions designed to fix problems and generally optimize sound quality.

- Dual 31-band Graphic Equalizers (stereo linkable)
- Dual 31-band Virtual Paragrophic Equalizers (stereo linkable)
- Dual 10-band Parametric EQ's per stereo side
- Dynamically-activated EQ
- Feedback Destroyer with Learning Mode
- Stereo Imager
- Compressor/Expander
- Limiter
- Digital Delay
- RTA/SPL/FFT Analyzer with Auto EQ function

### Dual 31-band Graphic Equalizers, 31-band Virtual Paragrophic Equalizers and 10-band Parametric.

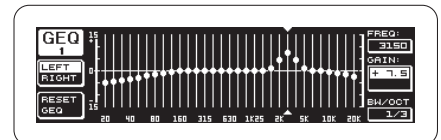

Naturally the DEQ2496 has phase-neutral digital graphic EQ...but in addition we've added a function that allows you to change the bandwidth of each frequency from standard 1/3 to as much as 59/3.

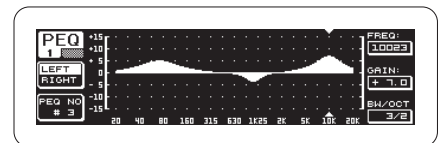

*Continued on next page*

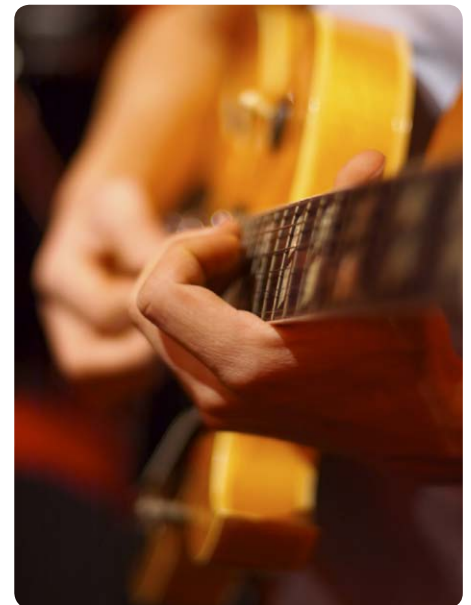

# ULTRA-CURVE PRO DEQ2496

- Ultra-high resolution 24-bit/96 kHz A/D- and D/A converters (113 dB dynamic range)
- Open architecture allowing future software updates via MIDI
- 2 high-performance 32/40-bit floating-point DSPs for ultimate sonic resolution
- Balanced inputs and servo-balanced outputs with gold-plated XLR connectors, stereo aux output, AES/EBU and S/PDIF inputs and outputs (XLR and optical)
- Internal switch-mode power supply for maximum flexibility (100 - 240 V~), noise-free audio, superior transient response and lowest possible power consumption
- High-quality components and exceptionally rugged construction ensure long life
- Conceived and designed by BEHRINGER Germany

Or, if you prefer the old-school approach to variable bandwidth, we've included 10-band parametrics that can be fine-tuned in increments down to 1/60 of an octave.

## Dynamically-activated EQ

Dynamic EQ automatically raises or lowers a defined frequency range based on volume level. It's literally a combination of an equalizer (with frequency center and bandwidth controls) and a dynamics processor (with ATTACK, RELEASE, THRESHOLD and RATIO parameters).

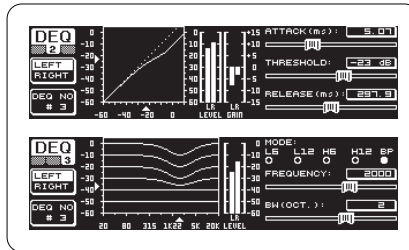

DEQ opens up a world of both creative mastering and PA problem solving possibilities. We've given you total control with multiple filter types including bandpass mode. And of course you can store DEQ settings for recall at any time manually or via MIDI.

## Feedback Destroyer with Learning Mode

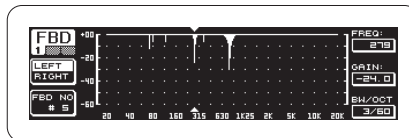

With the digital capabilities we've just listed, it's easy to see why we were able to include a highly-effective Feedback Destroyer (FBD) feature — it's essentially a dynamically-activated parametric EQ that "watches" the whole frequency spectrum in 1/60-octave bands and then instantly identifies and notches out feedback.

FBD can be run in AUTO mode to compensate for movements of performers on stage, or in SINGLE mode that locks onto individual frequencies and then varies the amount of attenuation and bandwidth depending on feedback stimulus — more suited to fixed microphone installations.

We also included a LEARN mode that generates short audio pulses, raises their gain until feedback occurs and then locks into potential trouble-causing band centers.

## Stereo Imager (WIDTH)

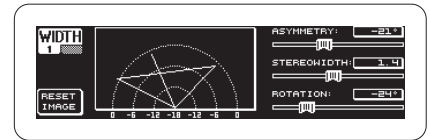

While usually considered a mastering technique, the ability to widen the stereo image can be useful in live sound work, too. When you hear it in action, we think you and your audience will be impressed.

*Continued on next page*

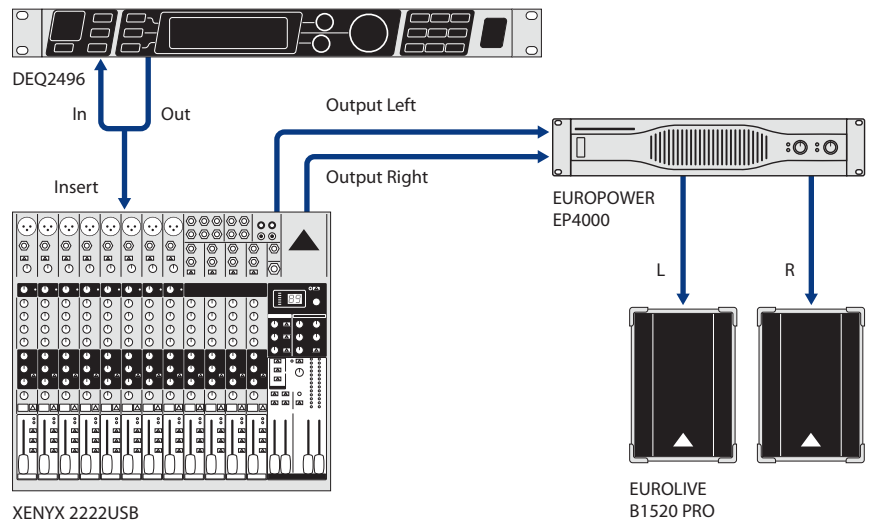

# ULTRA-CURVE PRO DEQ2496

The DEQ2496 WIDTH processor provides control over STEREOWIDTH (how clearly the two sides of the stereo image are separated from each other), ASYMMETRY (relative volume of left/right stereo signal), ROTATION (panning of stereo + mono in the stereo image), and a multipart SHUFFLE function than can generate an additional low-frequency Stereowidth effect.

### Compressor/Expander and Limiter

The DEQ2496 has a comprehensive set of dynamics processing tools that can be used as two independent channels or stereo linked.

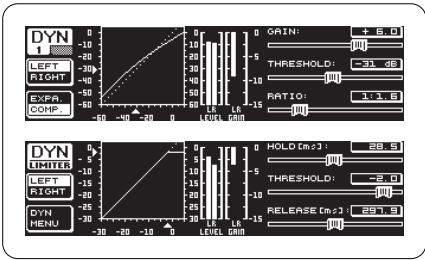

Everything you'd find on a dedicated compressor/expander is here including variable ratios from 1:1.1 to 1:100, ATTACK times from 0 to 200ms, 0-3dB variable knee and 20 to 4000ms RELEASE, all adjustable from a coarse/fine adjustment scale. The built-in separate LIMITER has Threshold, Hold and Release functions.

### Digital Delay

You can delay either the DEQ2496's Main or AUX outputs anywhere from 0 to 300ms and can process left and right channels independently.

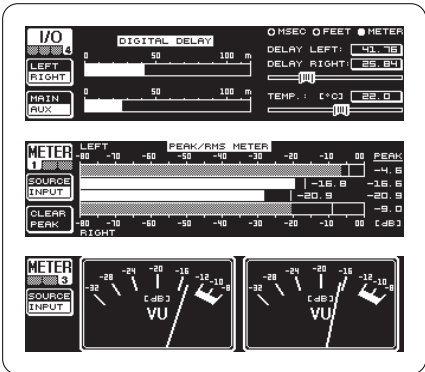

Not only can you specify time delay in feet or meters but simultaneously compensate for ambient temperature which affects sound speed!

### RTA/SPL/FFT Analyzer with Auto EQ function

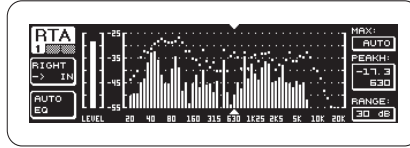

The DEQ2496 features an FFT real time analyzer for precise graphic display of 61 frequency bands. You can monitor main or digital inputs and outputs, AUX/digital out or a feed from an RTA microphone and display the results in a multitude of ways including funky retro VU meters.

You get all of the usual peak/hold, display rate and scale features you would expect from a professional measurement tool, plus our user-definable AEQ (Auto EQ function), which allows you to analyze and adjust your system's frequency response automatically (perfect for "roughing out" initial room adjustments).

In Graphic EQ mode, you can choose between UNCORRECTED response, which shows the mutual influence of adjacent bands, or select TRUE response to apply a specially developed algorithm that displays the actual results of the equalizer setting.

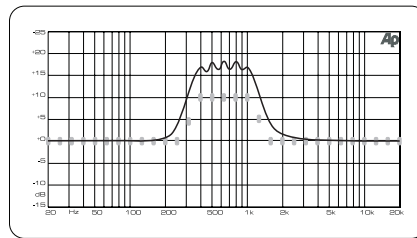

Graphic equalizer without frequency response correction (UNCORRECTED)

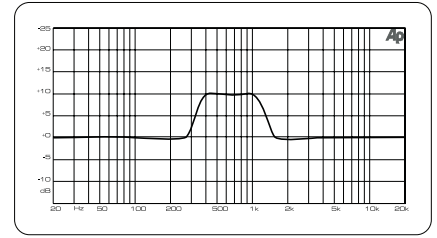

Graphic equalizer with frequency response correction (TRUE RESPONSE)

### Easy to set up and use.

The DEQ2496 has balanced inputs and servo balanced outputs with gold-plated XLR connectors, stereo aux output, AES/EBU and S/PDIF inputs and XLR and optical output. Configuration is intuitive, with on-screen block diagram displays and you get a separate RTA mic/line input with phantom power, a professional wordclock input and MIDI connections for full remote control, as well as preset dumps and system updates.

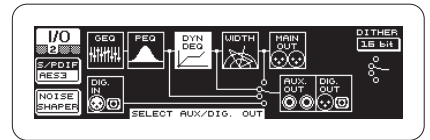

You can maintain up to 64 comprehensive user presets at a time and of course dump and load as needed. You can also save and recall individual modules such as DEQ, PEQ, WIDTH or DYN. These subsets of complete presets let you maintain most of a preset's settings but vary a few (such as graphic EQ) without having to generate a whole new preset.

### Built tough for the road, precise for the studio.

The DEQ2496 features high-quality 24-bit/96 kHz A/D and D/A converters and two high-performance 32/40-bit floating-point digital signal processors for incredible sonic resolution and 113 dB dynamic range.

The internal switch-mode power supply assures maximum flexibility (100-240V~), noise-free audio, superior transient response, lowest possible power consumption and freedom from power surge damage.

*Continued on next page*

# ULTRA-CURVE PRO DEQ2496

Compare features. Compare prices.  
Own ULTRACURVE.

Quite frankly, we believe that the DEQ2496 is the best multi-function processor value in the pro audio industry. Why pay much more for a status name?

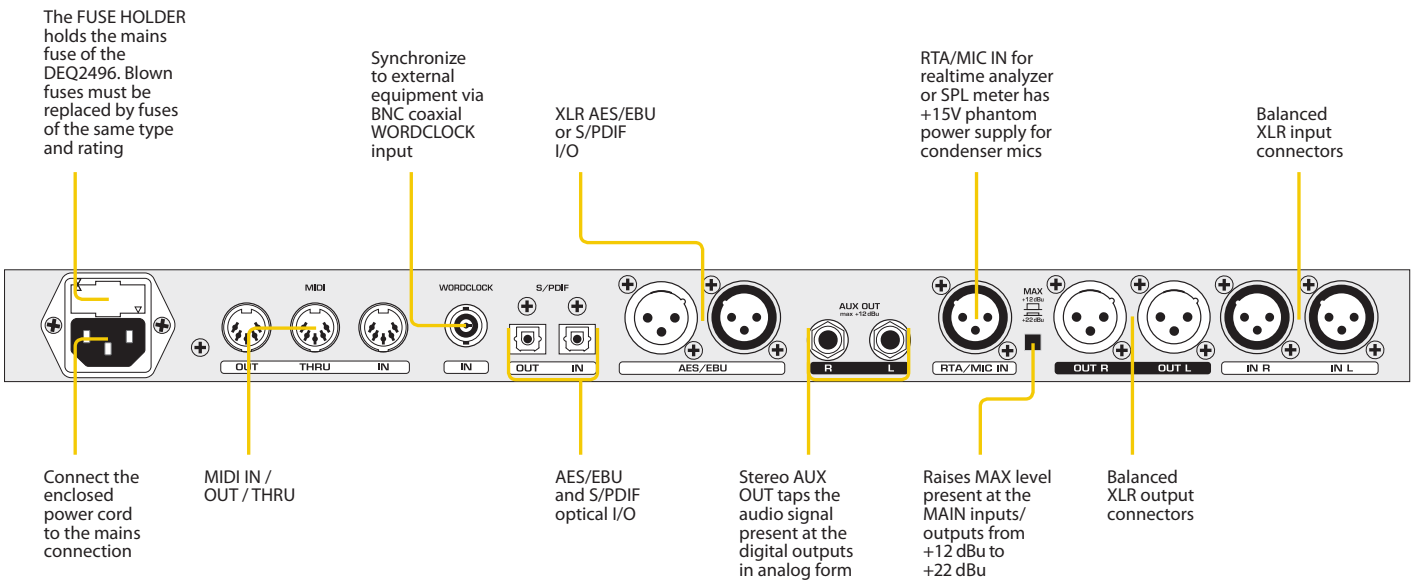
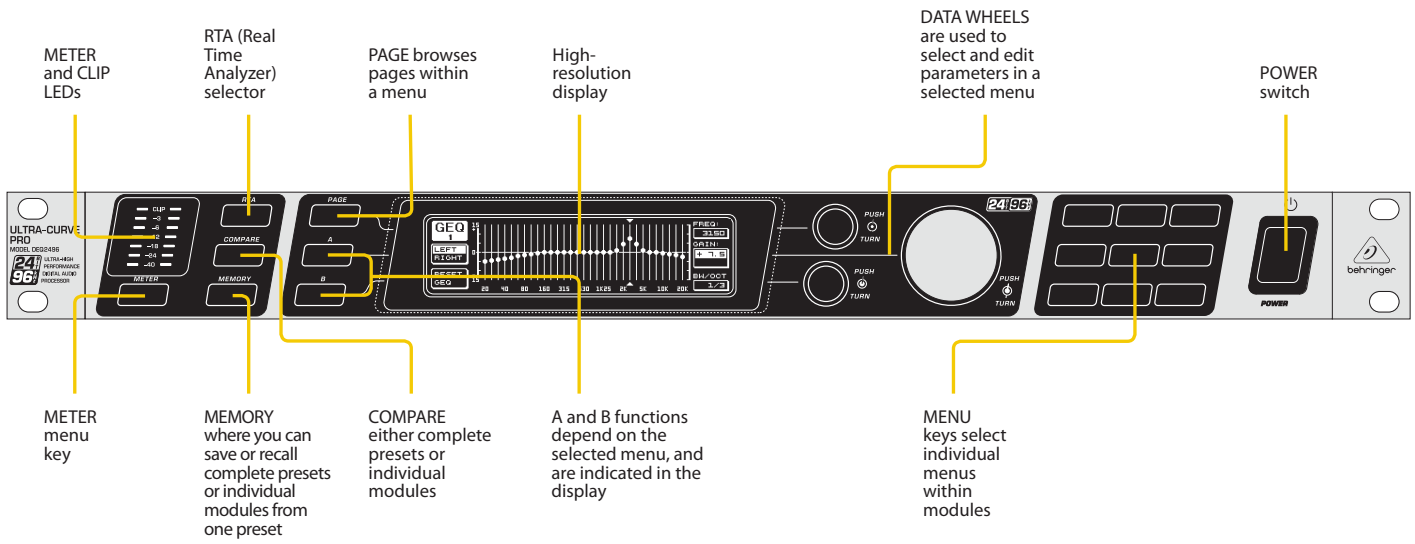

# ULTRA-CURVE PRO DEQ2496

## Monitor

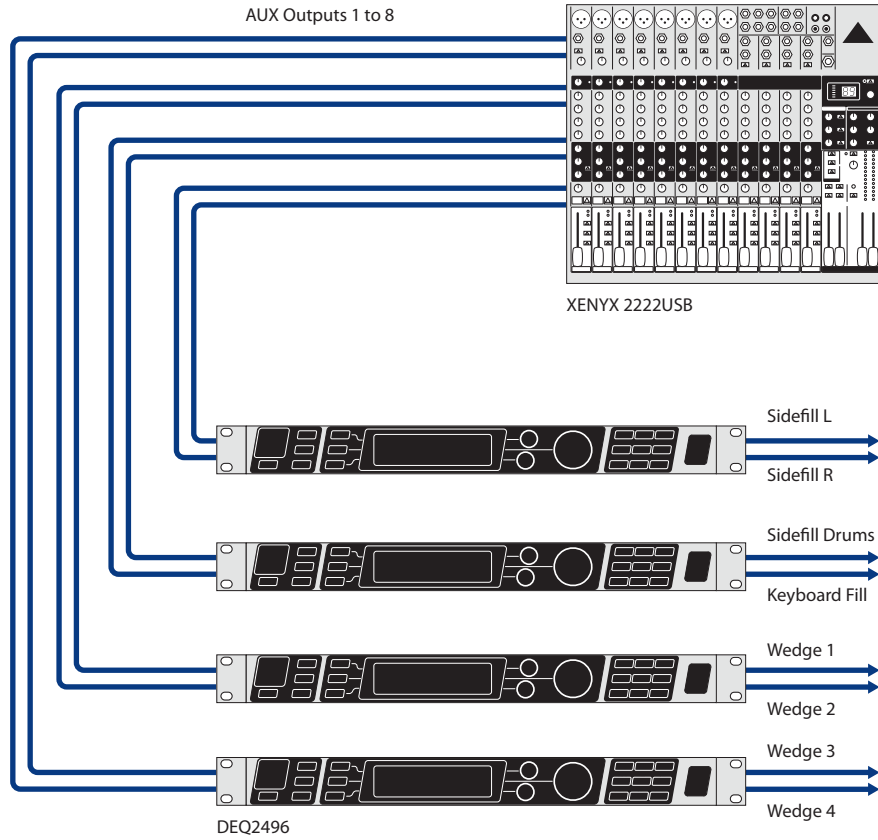

## Main

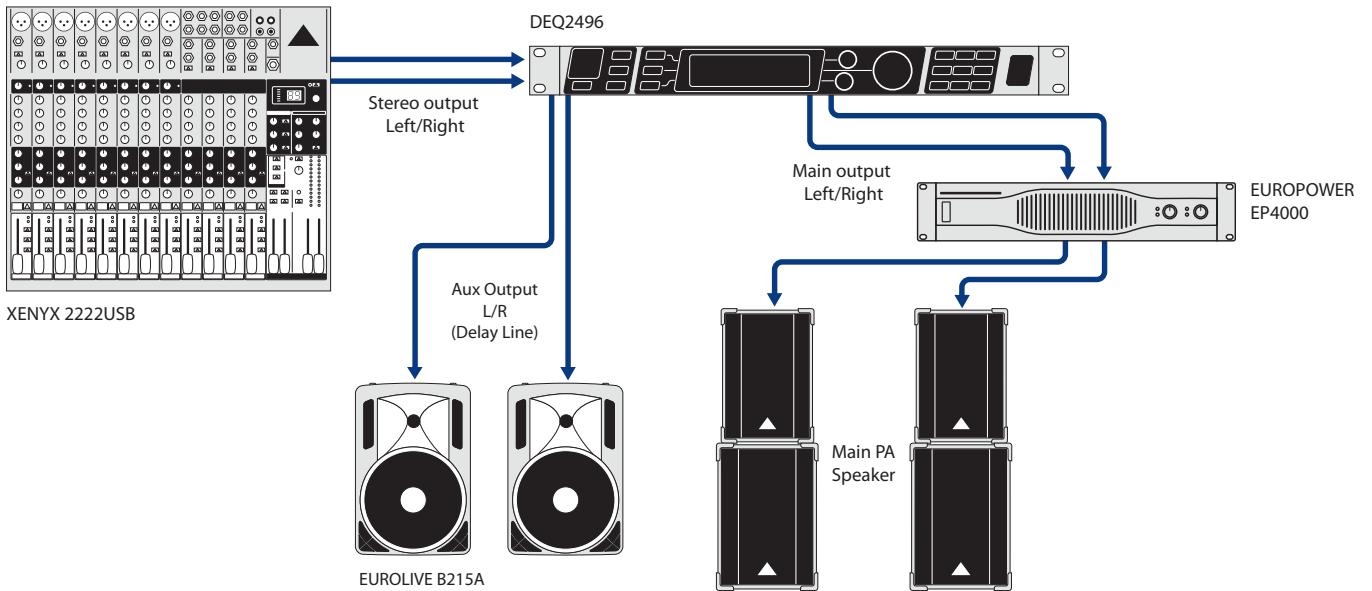

# ULTRA-CURVE PRO DEQ2496

## Analog inputs

Type	electronically balanced
Connector	XLR
Impedance	22 k $\Omega$
Max. input level	+12 or +22 dBu, switchable
CMRR	40 dB typ.

## Analog outputs (main)

Type	servo-balanced
Connector	XLR
Impedance	100 $\Omega$ at 1 kHz
Max. output level	+12 or +22 dBu, switchable

## Analog outputs (aux)

Type	servo-balanced
Conector	¼" stereo jack
Impedance	100 $\Omega$ at 1 kHz
Max output level	+12 dBu

## SYSTEM SPECIFICATIONS

Frequency range	10 Hz to 35 kHz (-1 dB) @ 96 kHz sampling rate
Signal-to-noise ratio	> 113 dB main input/output > 107 dB aux output
THD	0.007 % TYP. @ +4 dBu, 1kHz, unity gain
Crosstalk	< -92 dB/-95 dB

## Bypass

Type	Relay, hard-bypass in case of power failure
------	---

## Measurement microphone input

Type	electronically balanced
Input impedance	2k $\Omega$
Max. input level (LINE)	variable from -14 dBu to +22 dBu
Max. input level (MIC)	variable from -42 dBV/Pa to -6 dBV/Pa
Phantom power	+15 V, switchable

## Digital input 1

Type	XLR transformer-balanced
Standard	AES/EBU or S/PDIF
Input impedance	110 $\Omega$
Nom. Input level	0.2 – 5 V peak-to-peak

## Digital input 2

Type	TOSLINK optical
Standard	AES/EBU or S/PDIF

## Digital output 1

Type	XLR transformer-balanced
Standard	AES/EBU or S/PDIF
Impedance	110 $\Omega$
Output	3.5 V peak-to-peak

## Digital output 2

Type	TOSLINK optical
Standard	AES/EBU or S/PDIF

## Sync input

Type	BNC
Standard	Wordclock (1 x sample rate)
Input impedance	50 k $\Omega$
Nom. Level	2–6 V peak-to-peak

## MIDI interface

Type	5-pole Din jacks In/Out/Thru
Implementation	cf. MIDI implementation chart

## Digital processing

Converter	24-bit Delta-Sigma, 64/128-oversampling (AKM®)
Sample rate	44.1, 48, 88.2, 96 kHz

## Graphic equalizer (GEQ)

Type	digital 1/3-oct. EQ
Frequency Range	20 Hz to 20 kHz, 31 1/3-oct. bands according to ISO frequencies
Bandwidth	1/3-oct.
Control range	+15 to -15 dB

## Parametric equalizer (PEQ)

Type	max. 10 independent, fully parametric filters per channel
Frequency range	20 Hz to 20 kHz
Bandwidth	1/10 to 10 oct., shelving filters (6 and 12 dB)
Control range	+15 to -15 dB

## Dynamic equalizer (DEQ)

Type	max. 3 independent, fully parametric filters per channel
Frequency range	20 Hz to 20 kHz
Bandwidth	1/10 to 10 oct., shelving filters (6 and 12 dB)
Control range	+15 to -15 dB
Threshold	variable from 0 to -60 dB
Attack	0 to 200 msec
Release	20 to 4,000 msec
Ratio	1:2 to 1:100

## Feedback Destroyer (FBD)

Type	digital signal analysis for feedback identification
Filter	max. 10 digital notch filters per channel, programmable or as automatic feedback suppression system
Frequency range	20 Hz to 20 kHz
Bandwidth	1/10 to 1/60 oct.
Control range	0 to -60 dB

## Digital delay

Type	digital stereo delay
Max. delay time	300 ms, independently adjustable for each channel
Min. resolution	0.02 ms
Delay units	seconds, meters or feet

## Level meters

Type	digital level meter with simultaneous graphic display of Peak and RMS values and virtual analog VU meter
------	--

# ULTRA-CURVE PRO DEQ2496

## SPL meter

Weighting	dB (A), dB (C) or OFF
Microphone calibration	-42 dBV/Pa to -6 dBV/Pa

## Dynamics

Type	Expander or compressor with digital IGC (Interactive Gain Control)
Threshold	variable from 0 to -60 dB
Attack	0 to 200 msec
Ratio	1:1.1 to 1:100 msec

## Limiter

Type	Peak limiter (zero attack)
Hold	0 to 1,000 msec
Threshold	variable from 0 to -24 dB
Release	20 to 4,000 msec

## Real-time analyzer

Type	digital 61-band FFT analyzer
Frequency range	20 Hz to 20kHz, 61 bands According to ISO frequencies
Detectors	peak and average
Noise generator	pink noise, levels from 0 to -60 dB

## Display

Type	320 x 80 dot-matrix LC display
Backlighting	LED, orange
Contrast	adjustable

## Memory

Presets	64 memory locations with 16-character names, single modules can be recalled and saved
---------	---

## Power supply

Mains voltage	85 to 250 V~, 50/60 Hz
Power consumption	10 W typ.
Fuse	T 1 A H
Mains Connector	Standard IEC receptacle

## Dimensions/Weight

Dimensions (H x W x D)	1 ¾ x 19 x 8 ½" / 44.5 x 482.6 x 217 mm
Weight	approx. 2.05 kg
Shipping weight	approx. 3.5 kg

Please note these specifications are preliminary and conceptual in nature, and as such are subject to change as product development progresses. This information is supplied for market research purposes only and is not to be made public in any manner. This document is solely the property of The MUSIC Group, or one of its subsidiaries, and must be surrendered upon request of the owner.

For service, support or more information contact the BEHRINGER location nearest you:

**Europe**  
MUSIC Group Services UK  
Tel: +44 156 273 2290  
Email: CARE@music-group.com

**USA/Canada**  
MUSIC Group Services NV Inc.  
Tel: +1 702 800 8290  
Email: CARE@music-group.com

**Japan**  
MUSIC Group Services JP K.K.  
Tel: +81 3 6231 0454  
Email: CARE@music-group.com

Technical specifications and appearances are subject to change without notice and accuracy is not guaranteed. BEHRINGER is part of the MUSIC Group (music-group.com). All trademarks are the property of their respective owners. MUSIC Group accepts no liability for any loss which may be suffered by any person who relies either wholly or in part upon any description, photograph or statement contained herein. Colors and specifications may vary from actual product. MUSIC Group products are sold through authorized fulfillers and resellers only. Fulfillers and resellers are not agents of MUSIC Group and have absolutely no authority to bind MUSIC Group by any express or implied undertaking or representation. This manual is copyrighted. No part of this manual may be reproduced or transmitted in any form or by any means, electronic or mechanical, including photocopying and recording of any kind, for any purpose, without the express written permission of MUSIC Group IP Ltd. ALL RIGHTS RESERVED. © 2012 MUSIC Group IP Ltd. Trident Chambers, Wickhams Cay, P.O. Box 146, Road Town, Tortola, British Virgin Islands. 985-10000-00284