

# **TOMO** 2 in 1 STEM Robotic Kit

GRAPHICAL PROGRAMMING, ELECTRONICS AND ROBOTICS

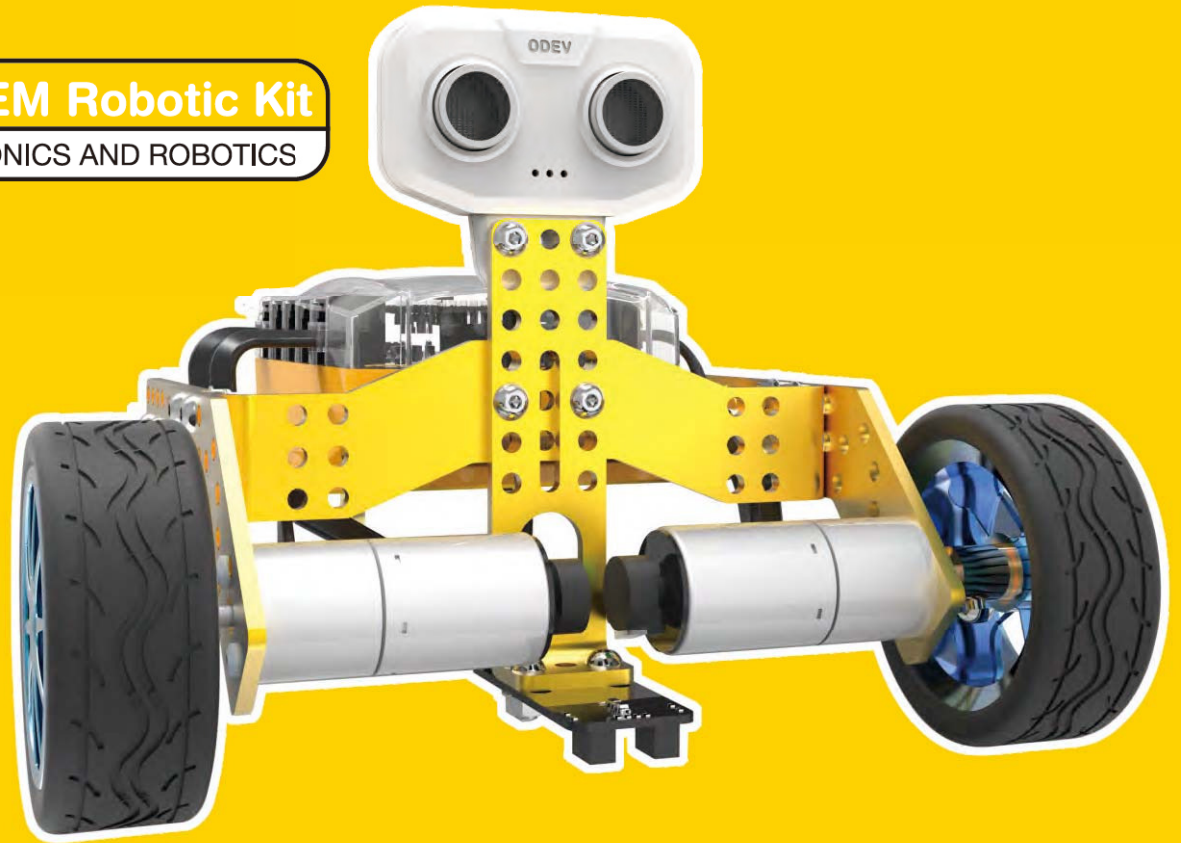

**User Manual**

## Important Safety Instructions

1. Please read all instructions before using the product.
2. The product is intended for children over 8 years of age; adult assistance and supervision is recommended.
3. Keep the electronic components away from water; if it is exposed to water remove the master control box and take the batteries out. Allow time for the parts that were wet to be completely dry before using.
4. The product contains small parts. Please keep it away from children under 3 years old.
5. When the LED light is on, avoid direct shooting on eyes.

## Disclaimer

This product is designed for indoor use. Using it in an outdoor environment with a rough surface (i.e., sandy, wet, rocky surface) may cause damage to the product.

We are not responsible for any damage/injury caused by misuse of the product whether that be indirect or direct.

### FCC Compliance Statement

This device complies with part 15 of the FCC Rules. Operation is subject to the following two conditions: (1) This device may not cause harmful interference, and (2) this device must accept any interference received, including interference that may cause undesired operation.

Any Changes or modifications not expressly approved by the party responsible for compliance could void the user's authority to operate the equipment.

Note: This equipment has been tested and found to comply with the limits for a Class B digital device, pursuant to part 15 of the FCC Rules.

These limits are designed to provide reasonable protection against harmful interference in a residential installation. This equipment generates, uses and can radiate radio frequency energy and, if not installed and used in accordance with the instructions, may cause harmful interference to radio communications. However, there is no guarantee that interference will not occur in a particular installation. If this equipment does cause harmful interference to radio or television reception, which can be determined by turning the equipment off and on, the user is encouraged to try to correct the interference by one or more of the following measures:

- Reorient or relocate the receiving antenna.
- Increase the separation between the equipment and receiver.
- Connect the equipment into an outlet on a circuit different from that to which the receiver is connected.
- Consult the dealer or an experienced radio/TV technician for help.

This equipment complies with FCC radiation exposure limits set forth for an uncontrolled environment. This transmitter must not be co-located or operating in conjunction with any other antenna or transmitter.

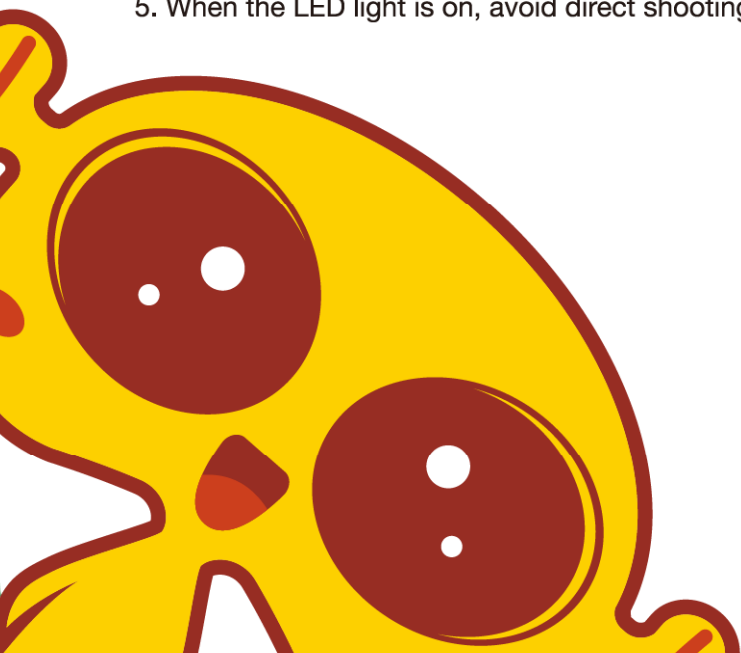

## Table of Contents

### 1.Product Description

Introduction .....	01
Parts List .....	02
How To Use The Tools .....	03
Main Control Panel .....	04
Battery Guide .....	05
Wiring Diagram .....	06

### 2.Assembly Instructions

Tricycle .....	07
Dicycle .....	14

### 3.How The Sensor Work

Gyro Sensor .....	19
Ultrasonic Sensor .....	20
Tracking Sensor .....	21

### 4. APP

ODEV Explorer .....	22
ODEV Blockly .....	23

### 5.FAQ .....

24

- **Tricycle**

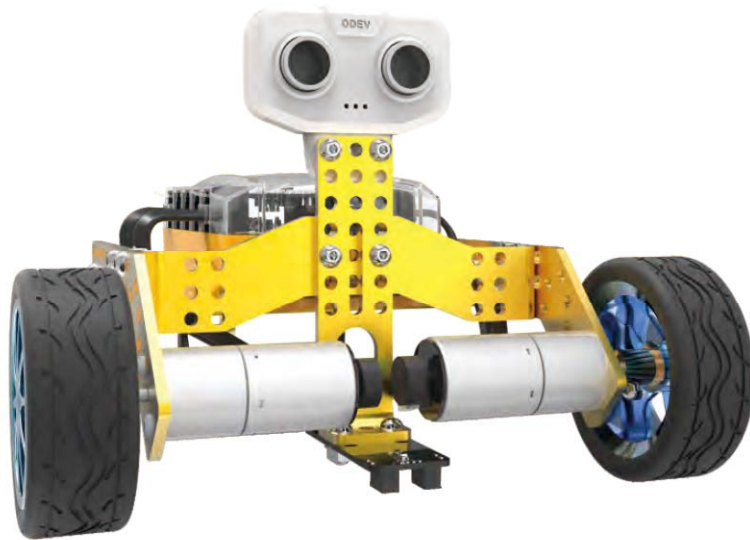























- **Dicycle**



Tomo is a 2-in-1 educational programming robot kit, which can be assembled as either an intelligent tricycle or a smart balance dicycle. The Tomo can be controlled through two apps, the “ODEV Explorer” and the “ODEV Blockly”. Both of which can be found on the Apple App Store and Google Play. The ODEV Explorer app is for beginners and for more advanced users please see the ODEV Blockly app. You can check the function of these apps on pages 22-23.

## ● Parts List

2 × middle bracket		2 × motor wire		2 × nut M3	
1 × front bracket		2 × sensor wire		22 × nut M4	
2 × corner plate		1 × roller ball		2 × wheel	
2 × connection plate		1 × double-ended hex driver		2 × copper cylinder M3	
1 × L plate		1 × 7# wrench		2 × copper coupling	
1 × main control box		20 × screw M4 x 10mm			
2 × motor		2 × screw M4 x 16mm			
1 × ultrasonic sensor		6 × screw M3 x 6mm			
1 × tracking sensor		10 × screw M4 x 6mm			

### Fun Facts

Screw thread callouts is a term used to name specific types of screws. These names are determined by "M", the "Number" x length of the screw ("M" is the International Organization for Standardization common screw threading while "Number" refers to the diameter of the screw).

For example Screw M4x16mm

- M is the ISO common screw threading
- 4 is the diameter
- 16mm is the length of the screw

## ● How To Use The Tools

In the kit, we have included special installation tools, which you will use to assemble the robot. Learning to use these tools will make the assembly process much smoother.

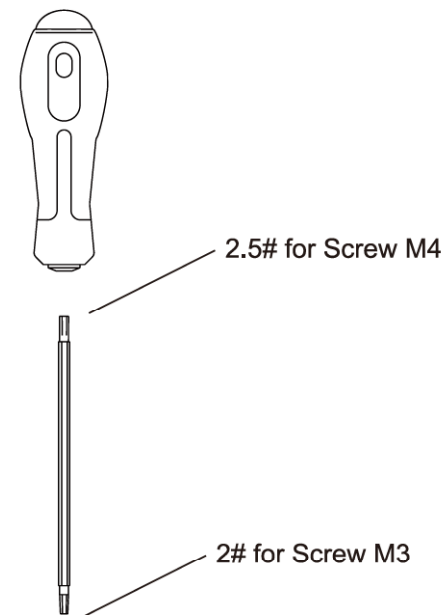
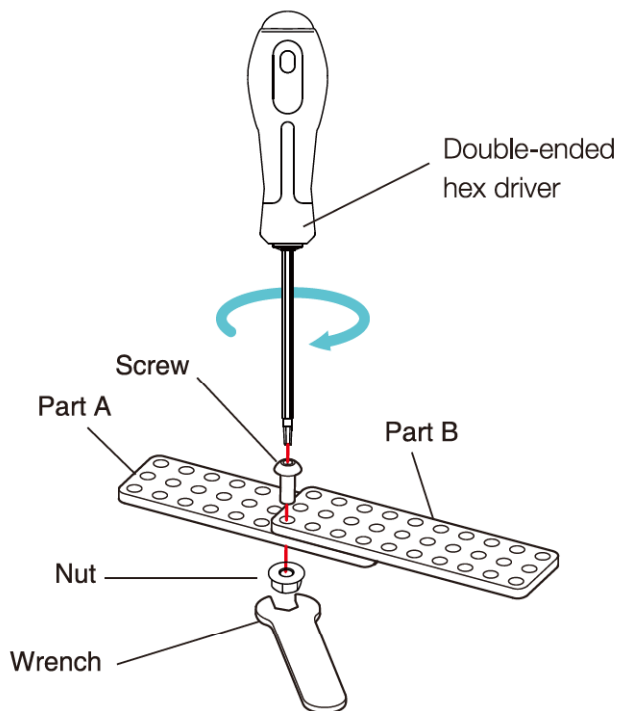

**Tip:** Please make sure the screw is tighten before operating the robot. To tighten the screw, use the wrench to hold the nut in place while using the screwdriver to tighten.

## ● Main Control Box

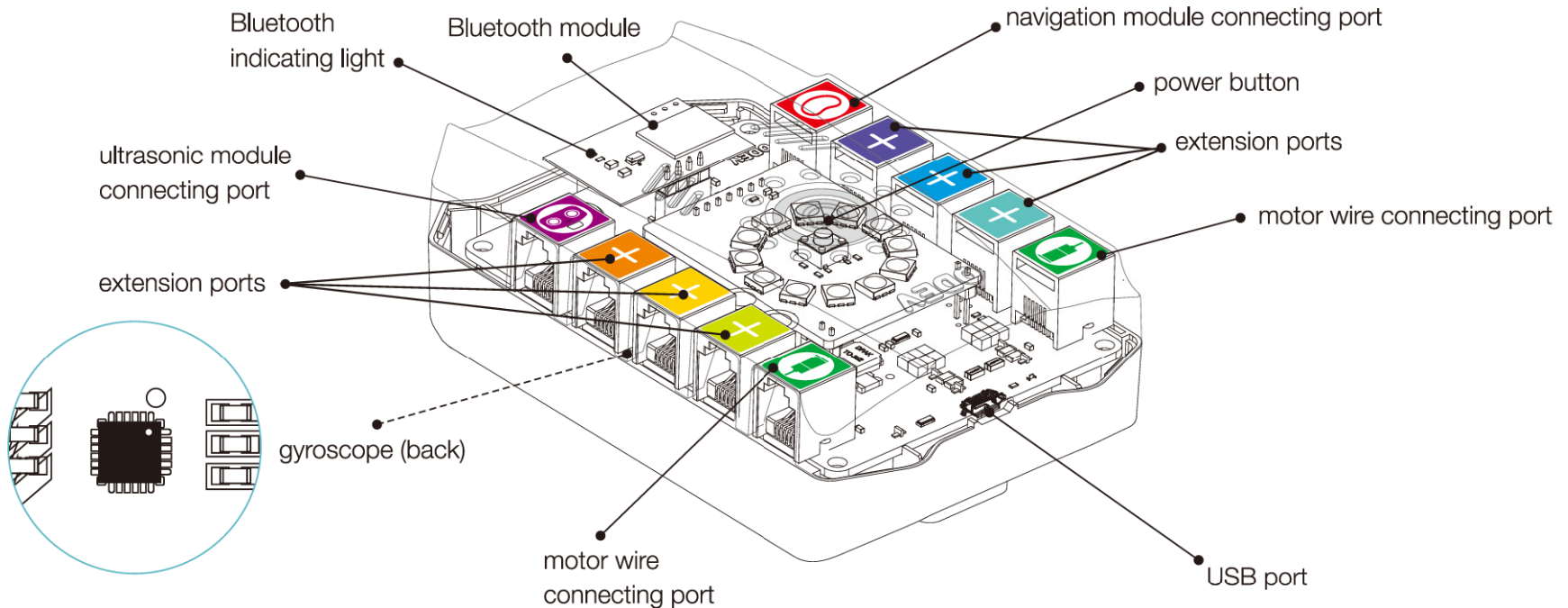

**Off:** press and hold the power button for 3 seconds until you hear a beep sound

**On:** press and hold the power button for 3 seconds until you hear a beep sound

**Get moving with Tomo:** After downloading the ODEV Explorer from Apple App Store or Google Play, open the app and click **"Controller"**. The screen will prompt you to select the Dicycle or the Tricycle configuration. Choose the option based on what you have built. Tap the Bluetooth connector button in the top right corner of the screen (gold circle) and place your device directly above Tomo to connect.

*(Please note: With the Dicycle configuration after successfully connecting you must toggle Tomo upright for the auto balance feature to begin)*

● **Battery User Guide**

**Please follow the user guide:**

1. Use only the standard size AA batteries (6pcs).
2. Do not mix old and new batteries; do not mix the batteries with different brands; do not mix the batteries with different types.
3. If the performance of the Tricycle or Dicycle is slow, it could mean that the battery is low. Please replace the batteries.
4. If the robot is put in idle for a long time, please take out the batteries.
5. After each use, please turn off the power to prevent energy lost.
6. When installing the batteries, please make sure the positive and negative sides of the batteries are installed correctly.

● **Remove the Main Control Box**

- ① Disconnect all the wires
- ② Press down the tail part of the control box
- ③ While pressing down, push the box towards to the back
- ④ Lift the box to remove

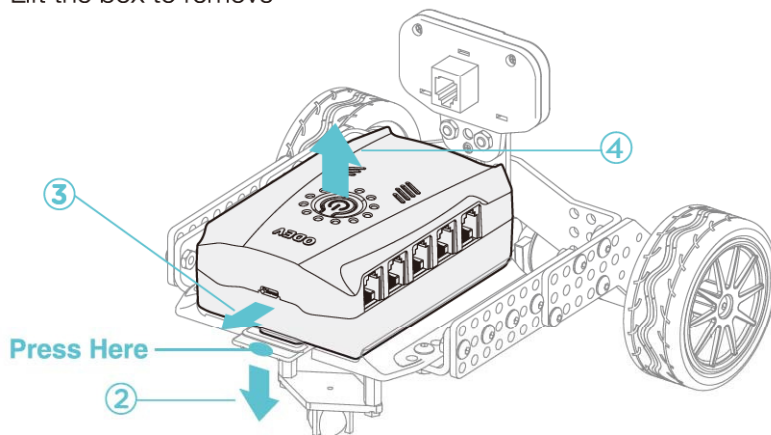

● **Replace the Battery**

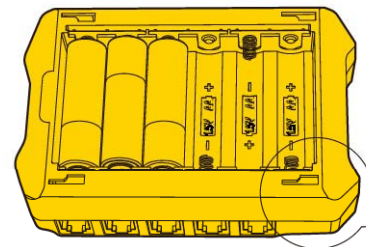

**Remove the Main Control Box to replace the batteries**

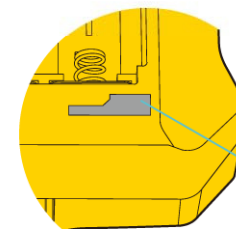

Socket

● **Install the Main Control Box**

- ① Align the control box to its base as shown
- ② Slide the control box towards to the front

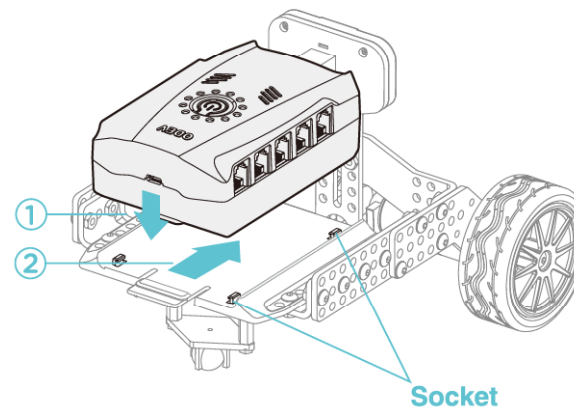



● **Wiring Diagram**

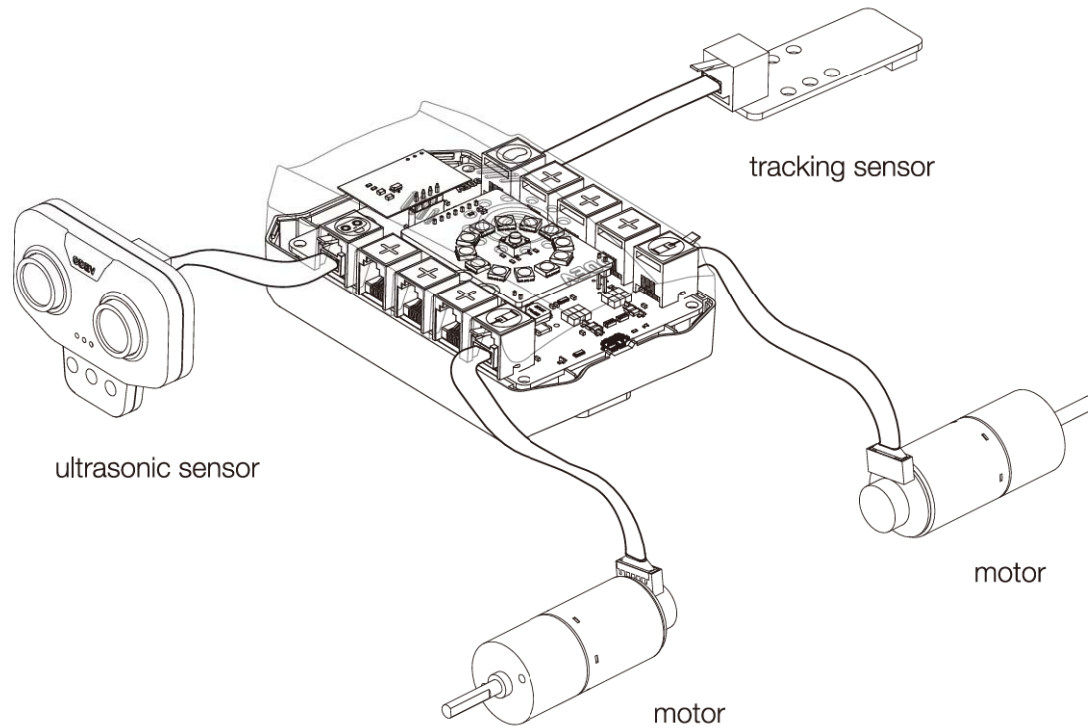

● Tricycle Assembly Procedure

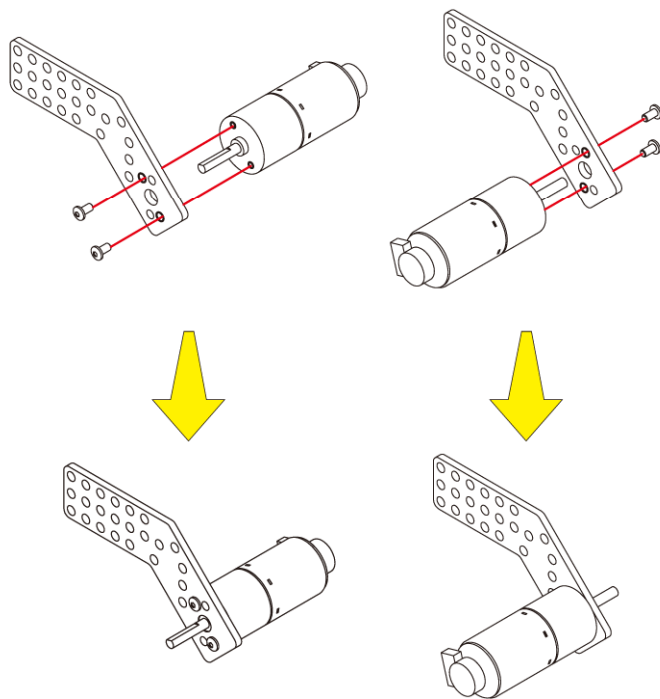
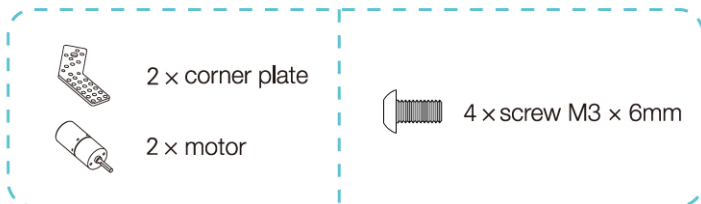

Step 1: install the right and left motor

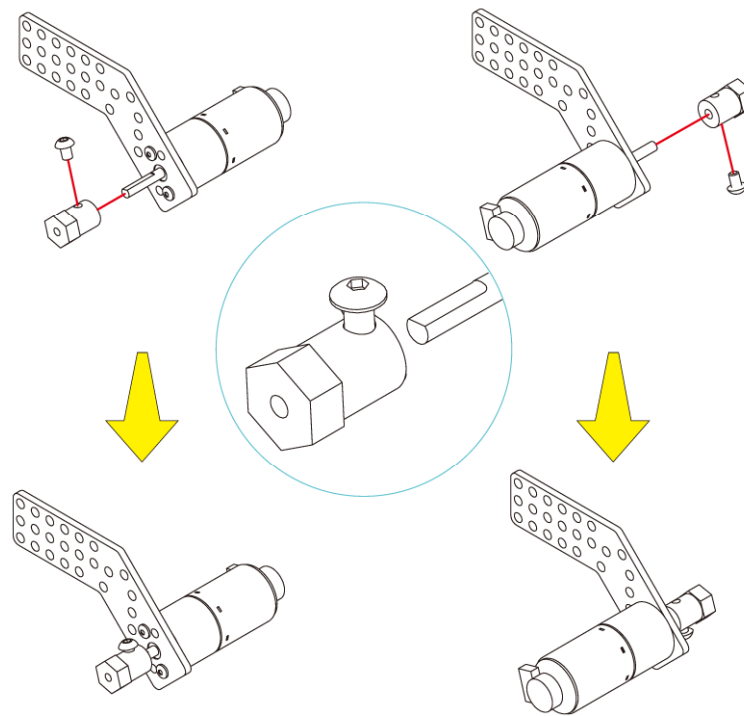
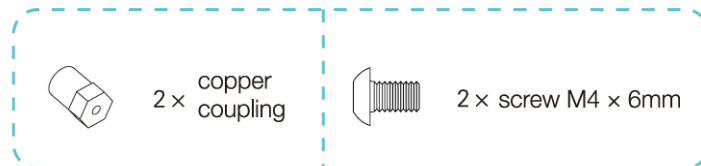

Step 2: install the right and left coupling



2 × wheel



2 × screw M4 × 6mm

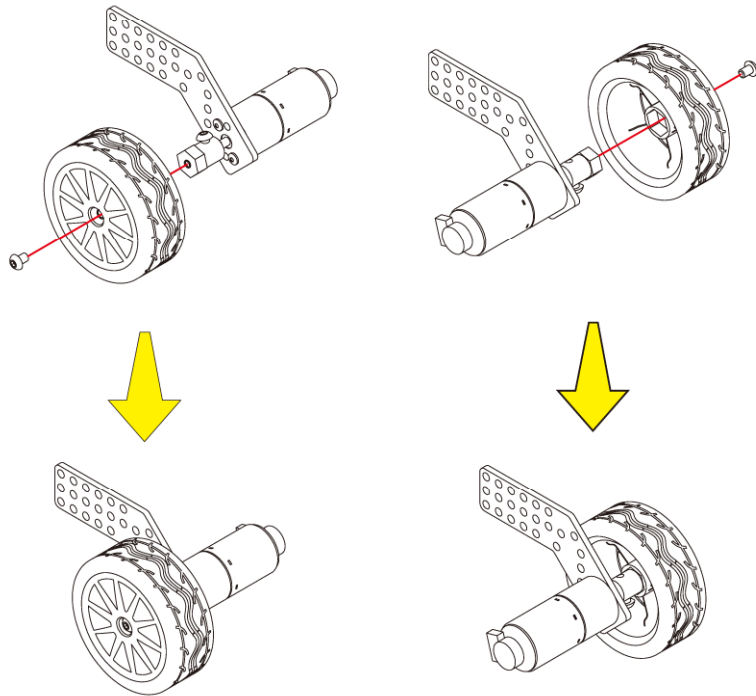

Step 3: install the right and left wheel



2 × motor wire

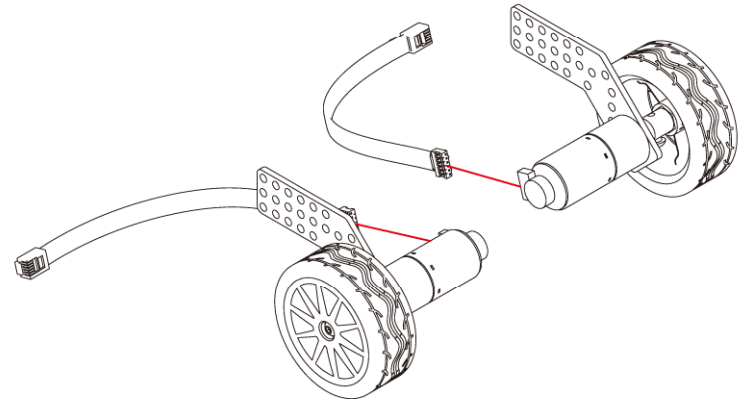

Step 4: connect the motor wires



1 × ultrasonic sensor



1 × tracking sensor



1 × L plate



2 × screw M4 × 16mm

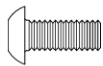

2 × screw M4 × 10mm



4 × nut M4

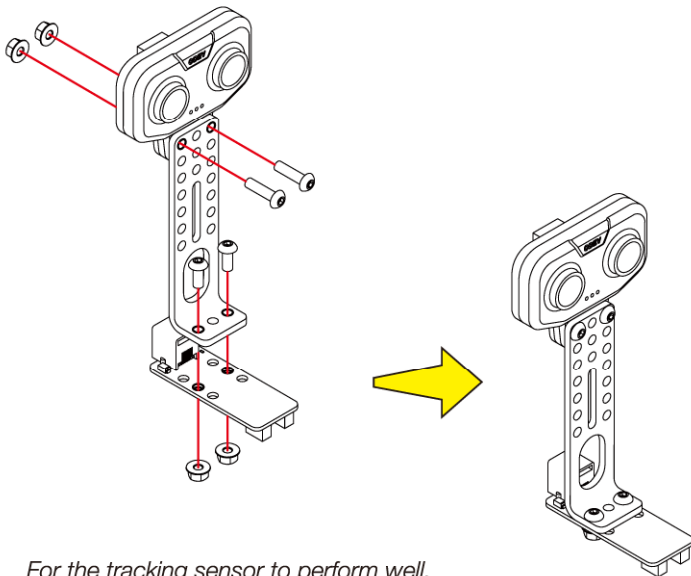

*For the tracking sensor to perform well, please make sure the sensor is installed parallel to the ground.*

Step 5: install the ultrasonic sensor and the tracking sensor



1 × front bracket

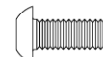

2 × screw M4 × 10mm



2 × nut M4

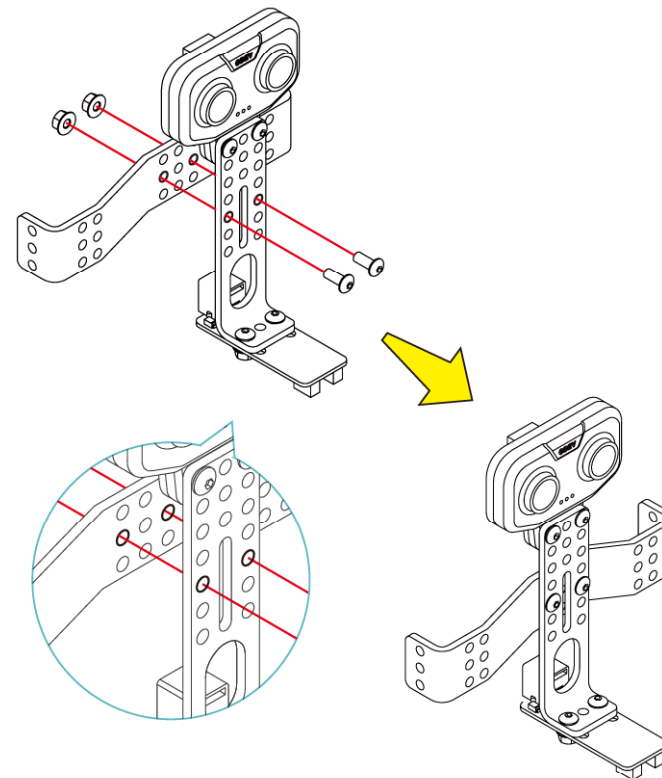

Step 6: attach the ultrasonic sensor and tracking sensor to the front bracket

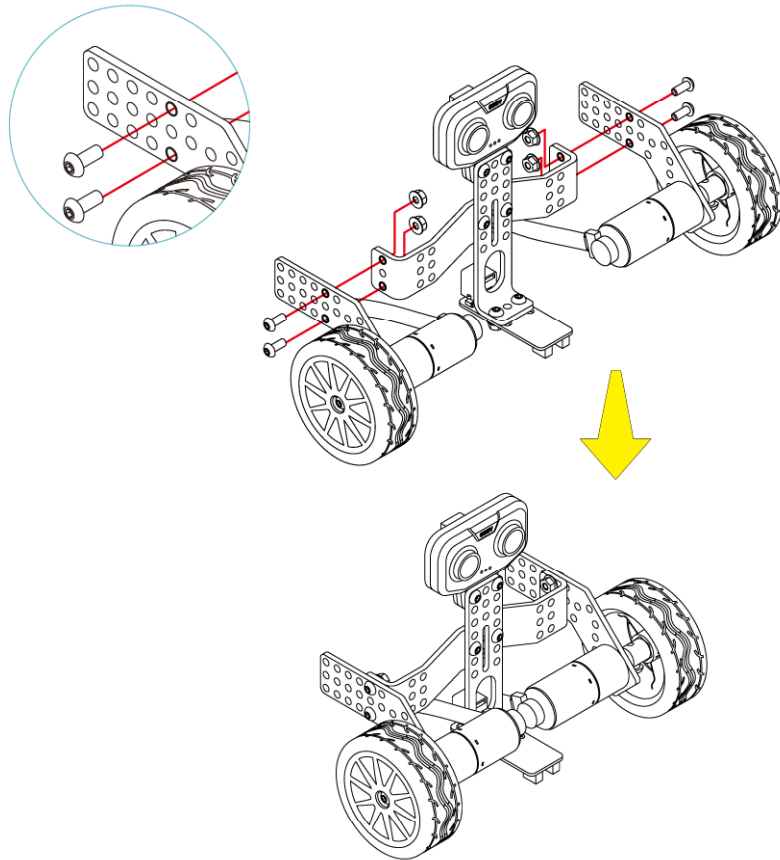
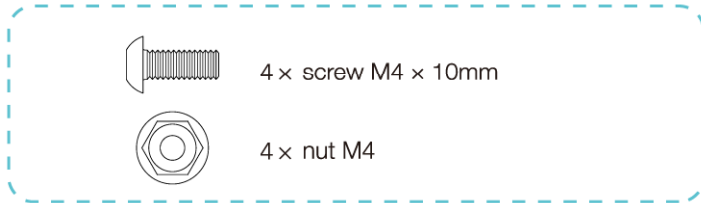

Step 7: attach the wheel assemblies to the front bracket

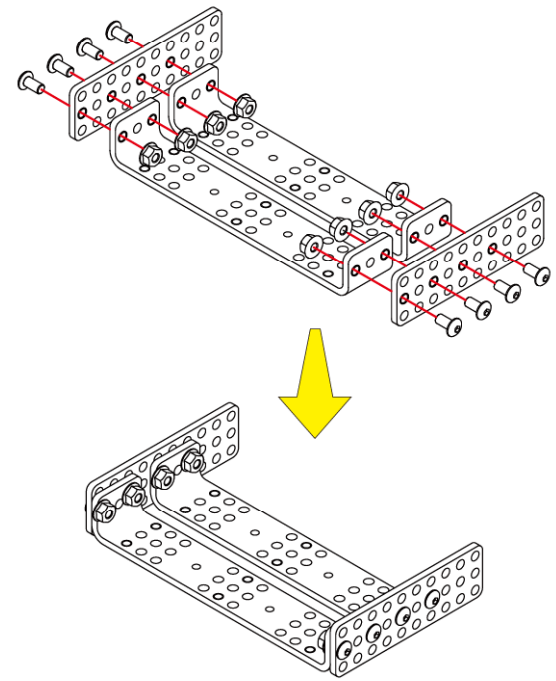
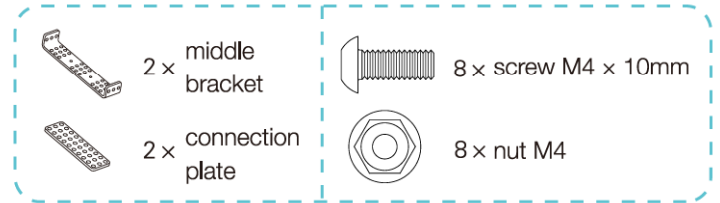

Step 8: assemble the middle brackets



2 × copper cylinder M3

1 × roller ball



2 × nut M3



2 × screw M3 × 6mm

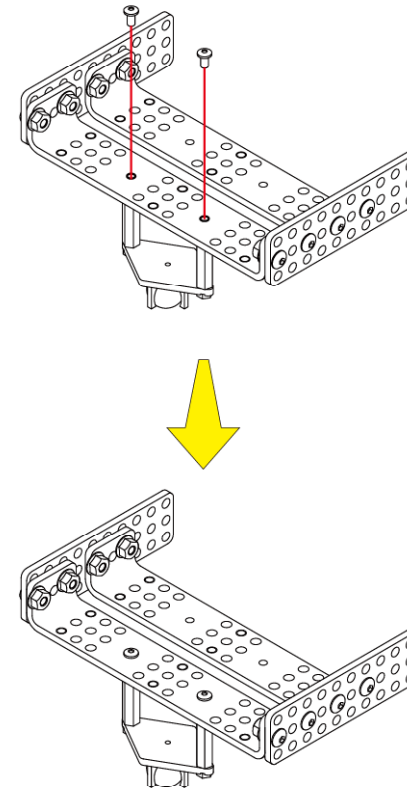
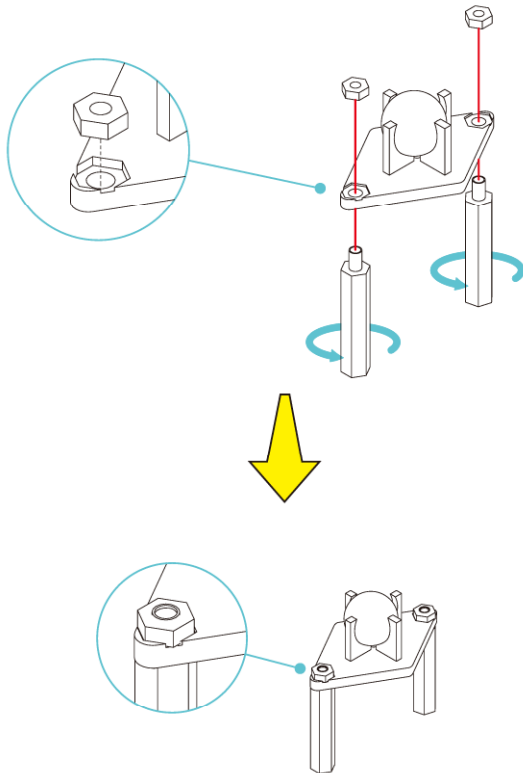

Step 9: install the roller ball

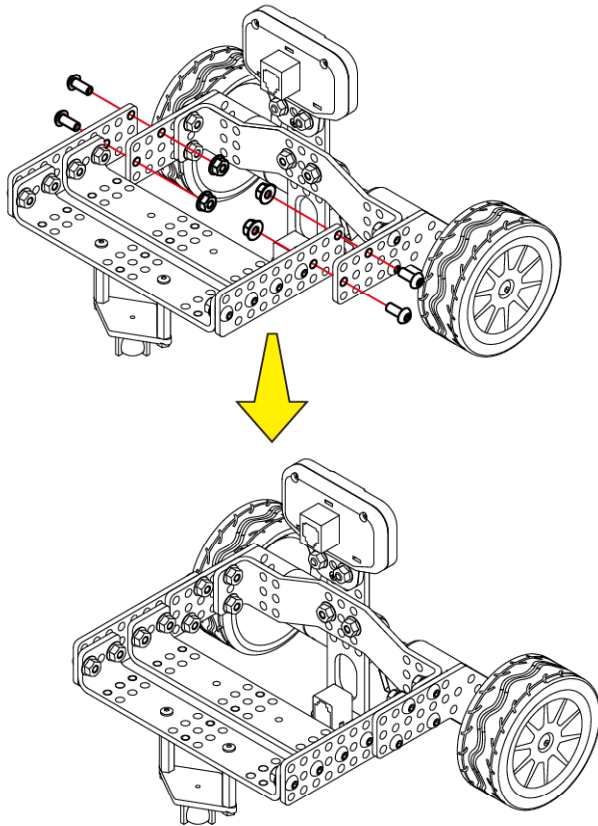
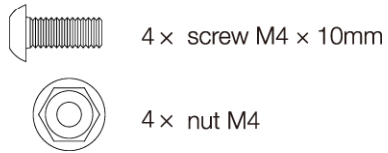

Step 10: attach the middle bracket to the front bracket

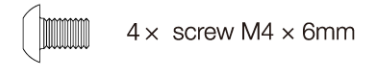

After completing step 11, please see page 5 and then 6 to install the batteries and connect the wires.

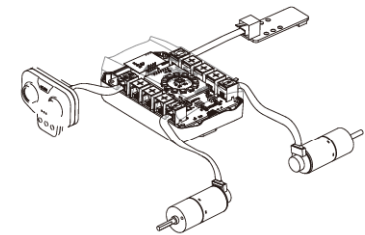

Go to page 6 to see wiring instructions

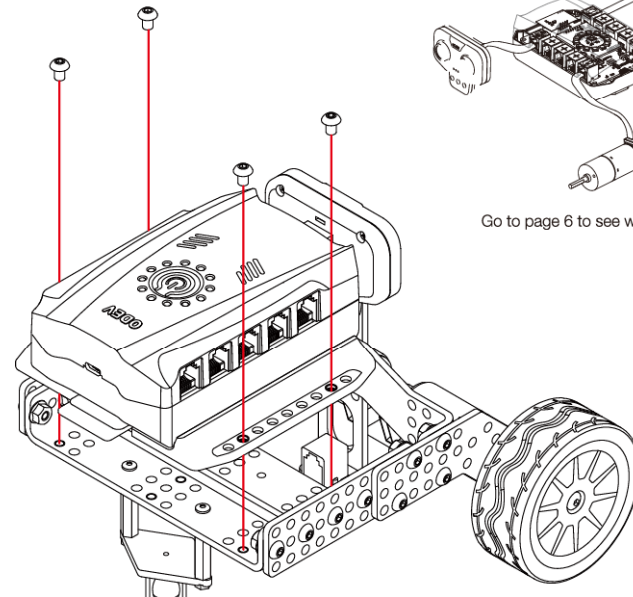

Step 11: install the main control box

- The Final Look of Tomo the Tricycle

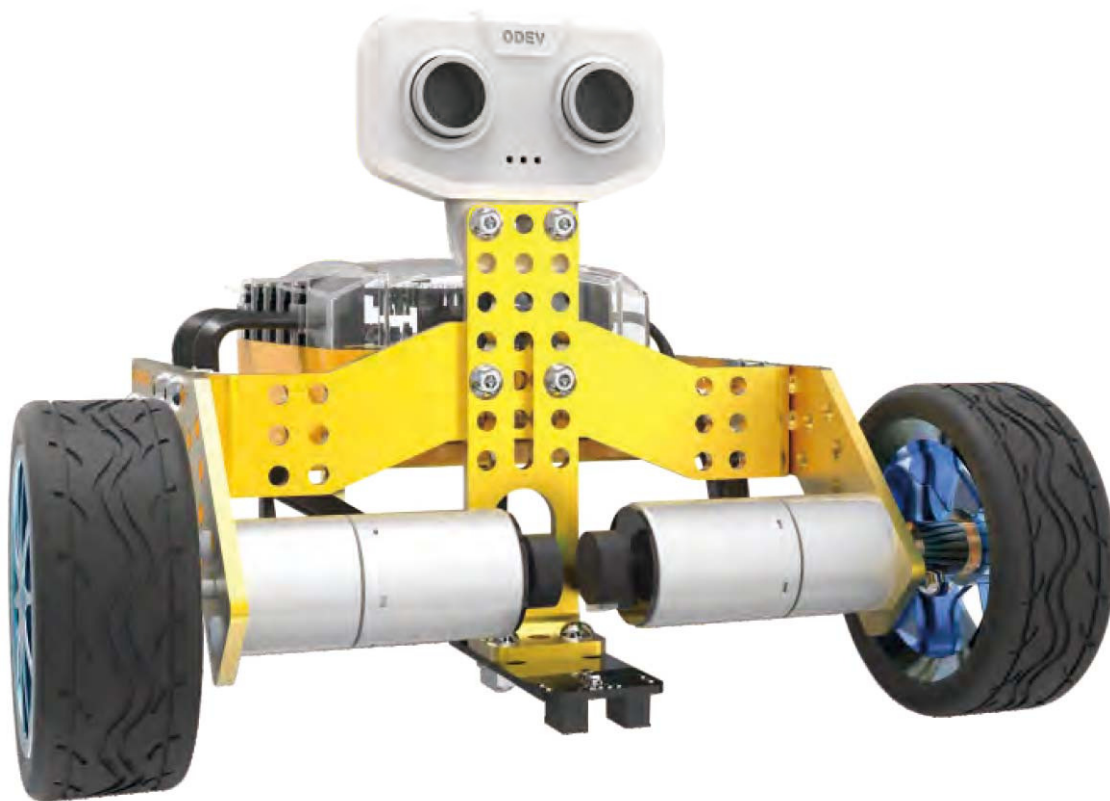



● Dicycle Assembly Procedure

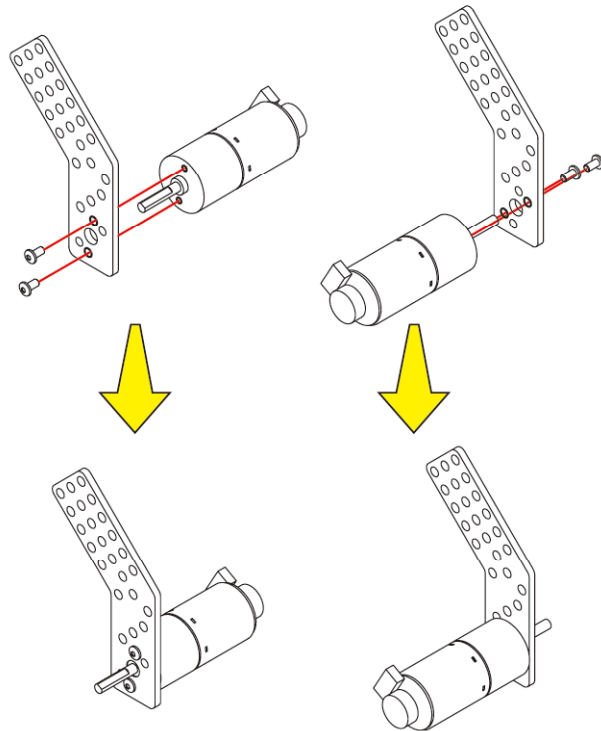
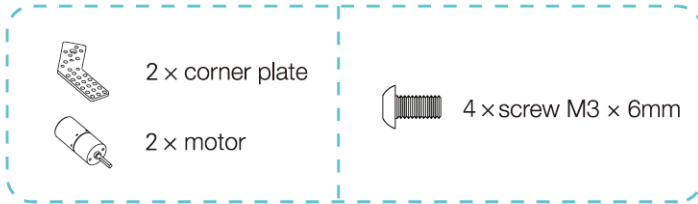

Step 1: install the right and left motor

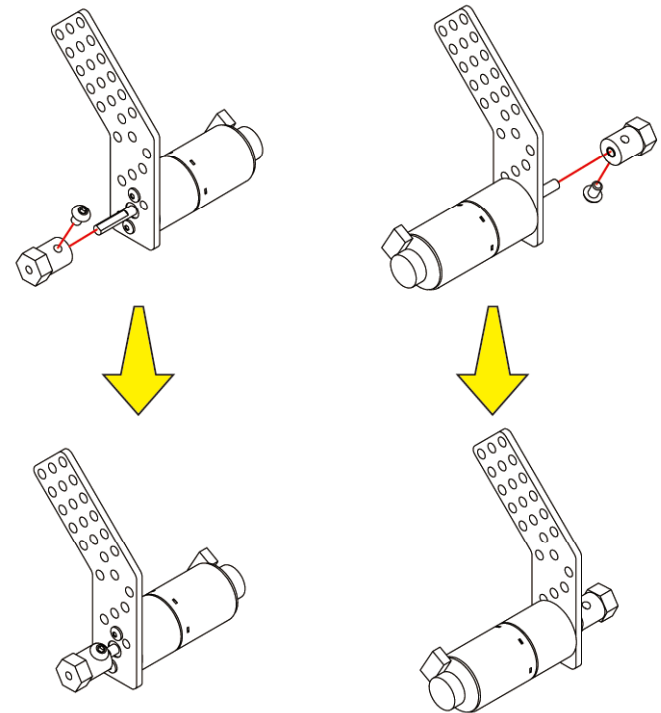
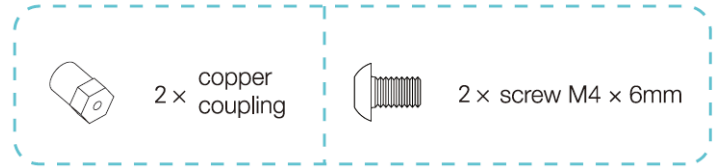



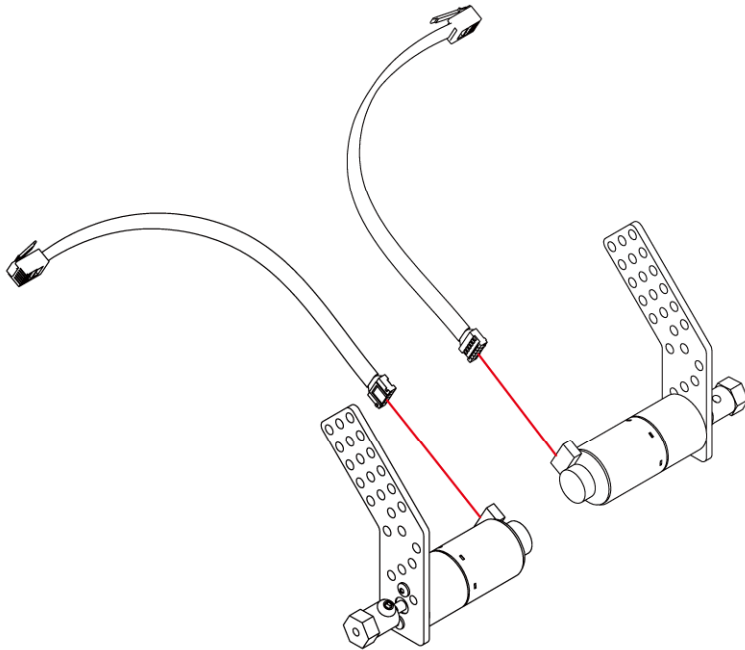
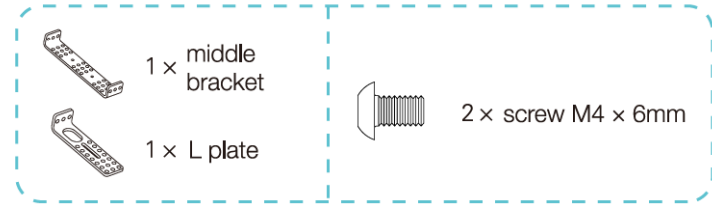
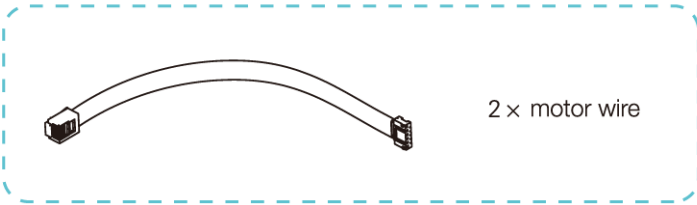

Step 2: install the right and left coupling

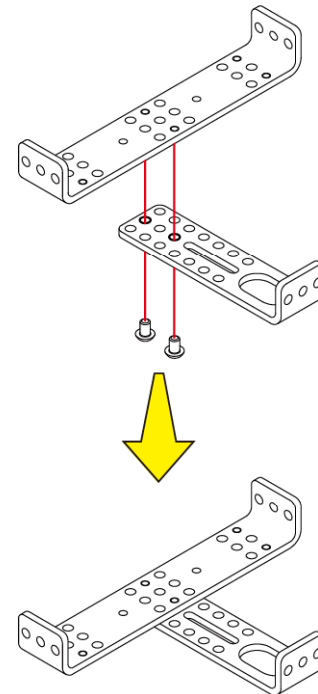

Step 3: connect the motor wires



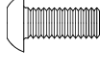

Step 4: assemble the middle bracket

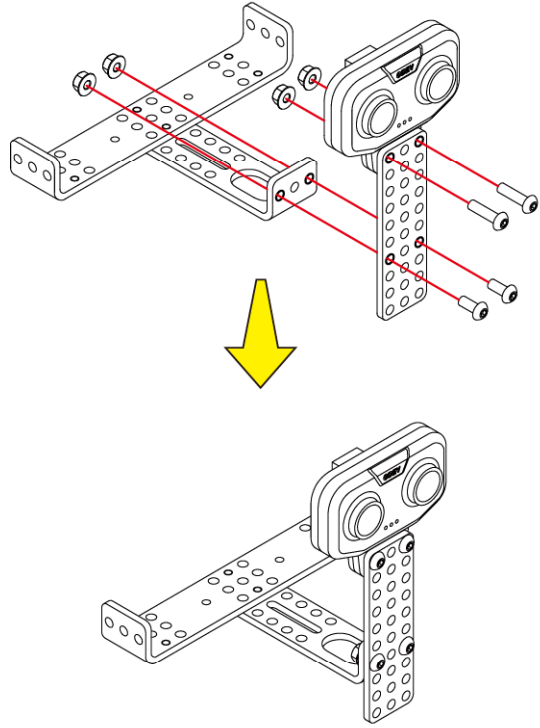
-  1 x ultrasonic sensor
-  1 x connection plate
-  2 x screw M4 x 16mm
-  2 x screw M4 x 10mm
-  4 x nut M4

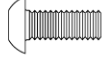

Step 5: install ultrasonic sensor

-  4 x screw M4 x 10mm
-  4 x nut M4

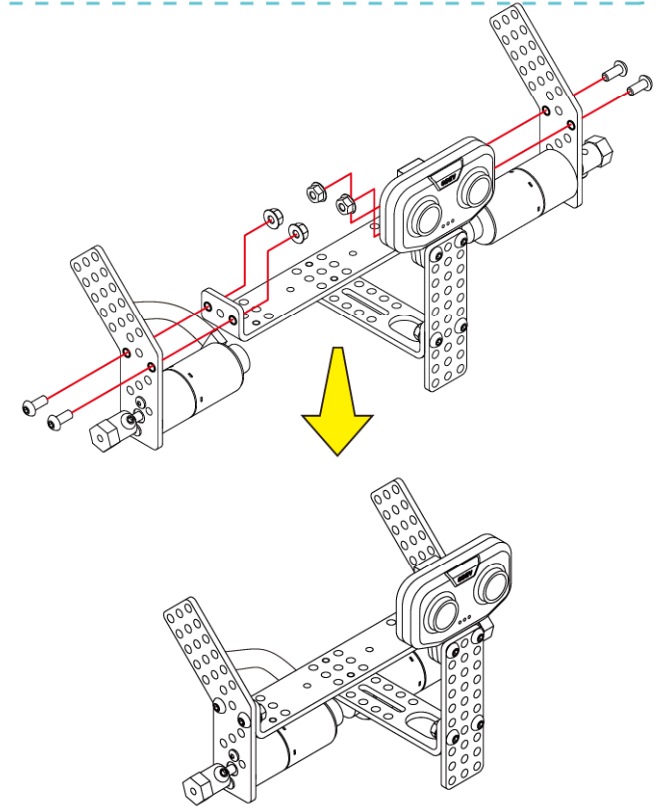

Step 6: install the motor assemblies



2 x wheel



2 x screw M4 x 6mm

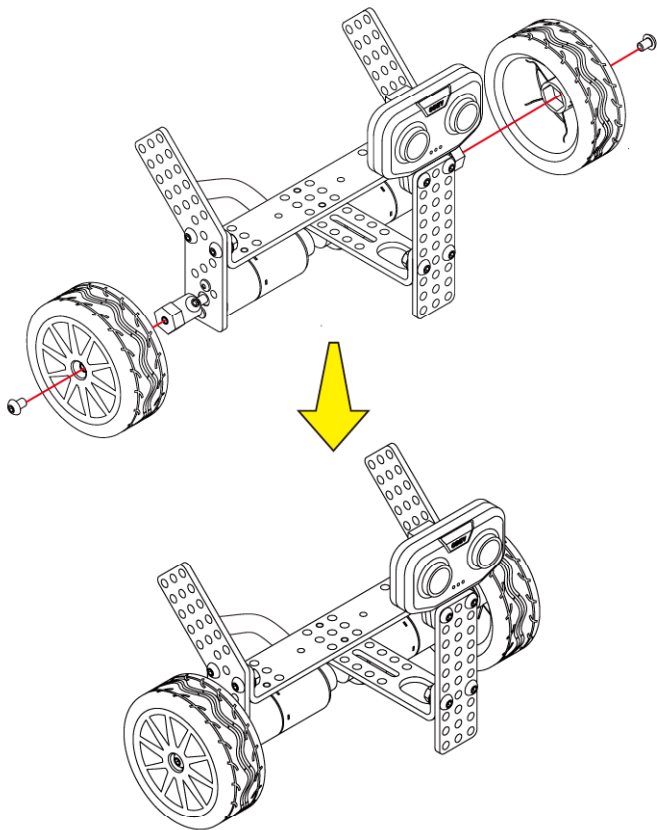

Step 7: install the wheels



1 x Main Control Box



4 x screw M4 x 6mm

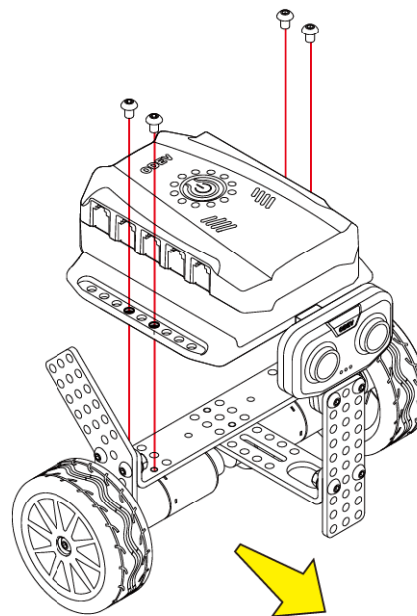

After completing step 8, please see page 5 and then 6 to install the batteries and connect the wires.

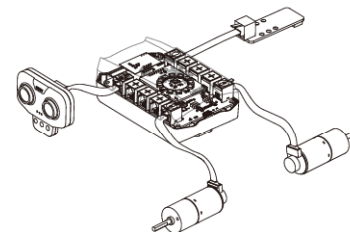

Go to page 6 to see wiring instructions

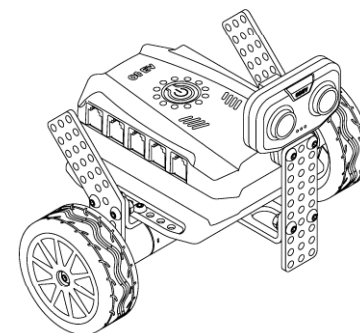

Step 8: install the main control box

- **The Final Look of Tomo the Dicycle**

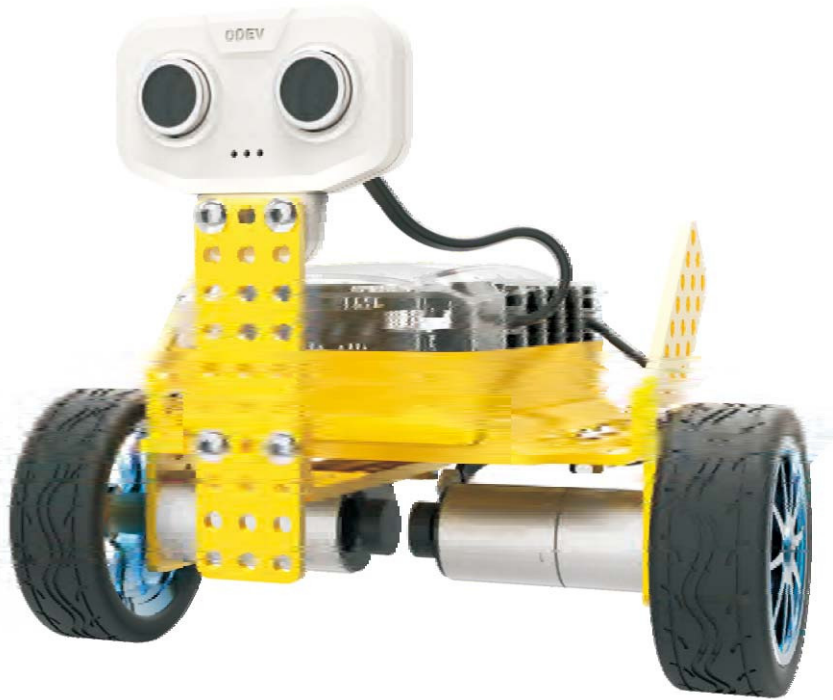

## ● Gyro Sensor

The gyro sensor integrated behind the main control plate can detect the motion of the robot. After collecting the robot's motion information, the gyroscopic sensor will use motion controller to constantly adjust the motion of the robot to auto-balance the robot. The gyroscopic sensor technology has been used on a number of different applications such as RC products (Drones & Helicopters), and mobile devices for changing screen orientation.

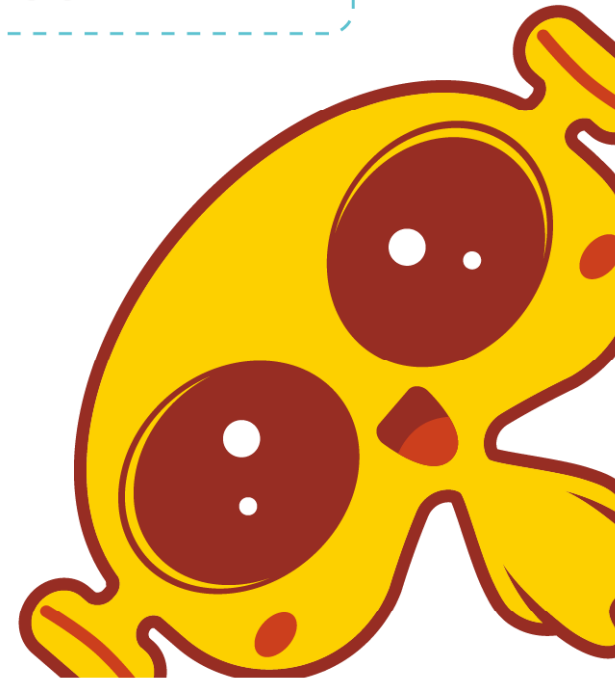
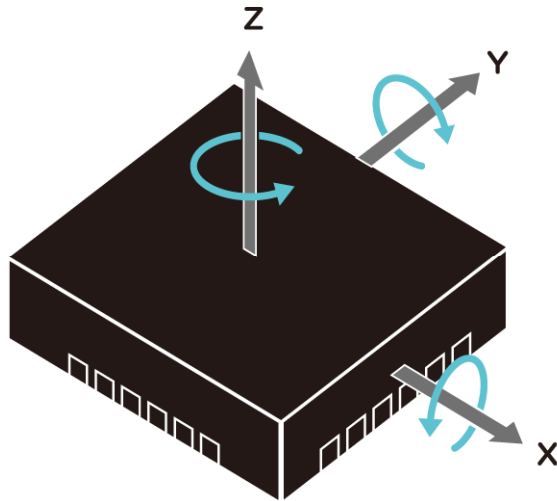

## ● Ultrasonic Sensor

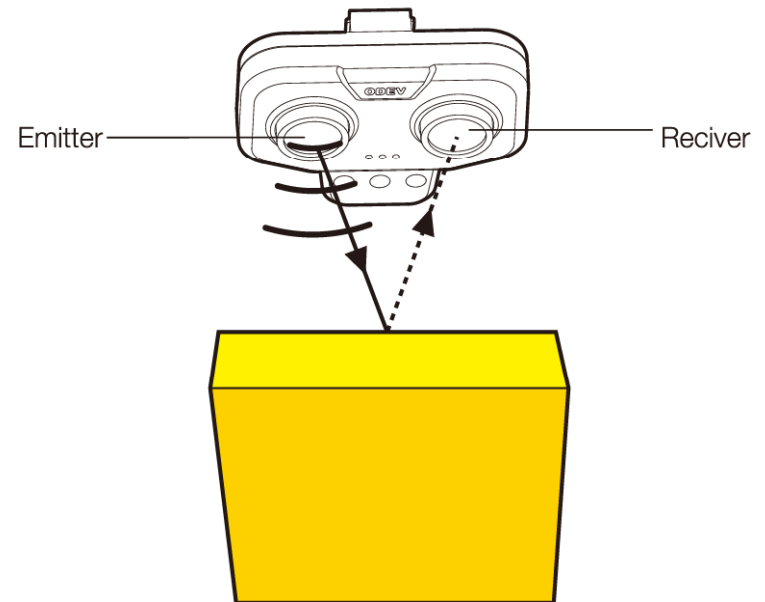

Ultrasonic sensor allows Tomo to avoid hitting objects through the use of its two probes that act as the receiver and the emitter. The emitter first emits ultrasonic waves in all directions. As the emission begins, it triggers an internal timer to start counting. When an ultrasonic wave hits an object and bounces back, the receiver will process it and the internal timer will stop. The velocity of the ultrasonic wave in the air is 340m/s. Based on time that it took to hit the object and come back, the distance between the object and the emitter can be calculated as  $\text{Distance} = \frac{340\text{m/s} \times \text{Time}}{2}$ .

## ● Tracking Sensor

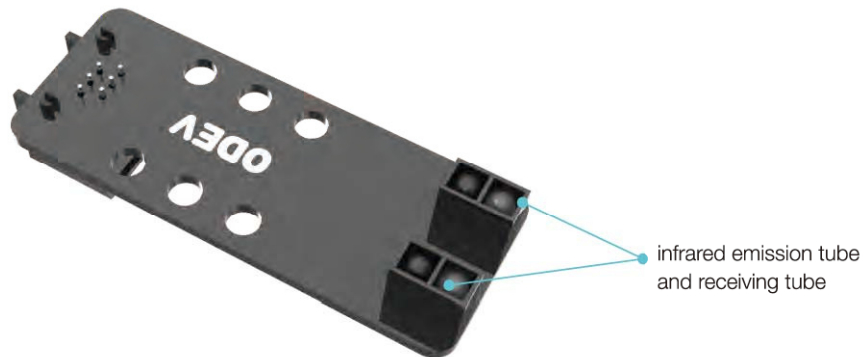

The tracking sensor can identify the lines on the navigation map that is included using the infrared emission and infrared receiving tube, which has a high speed of detection.

You can also make your own tracking map with a black marker or tape (the width of the line should be at least 1 inch).

*Note: For more ways of using tracking sensor and more map ideas, please visit our website at [www.odevbot.com](http://www.odevbot.com).*

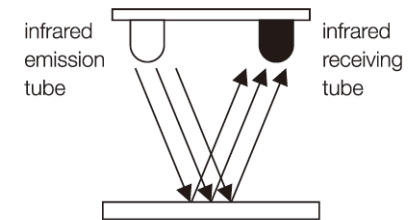

White side can reflect more infrared light.

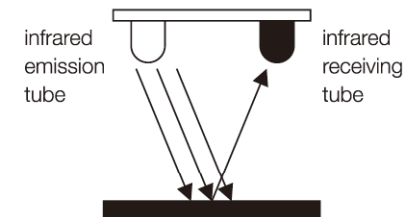

Dark side can only reflect a little infrared light.



## ● APP: ODEV Explorer

ODEV Explorer app is used by beginners to control Tomo. It includes four sections: Control, Task, Programming, and Cloud. After installing ODEV explorer on your smart phone or tablet, you can use your device to control the robot via Bluetooth on the control network. Scan the below QR code to download the app. (ODEV Explorer can be found from Google Play or Apple App Store)



Scan the QR to download  
ODEV Explorer

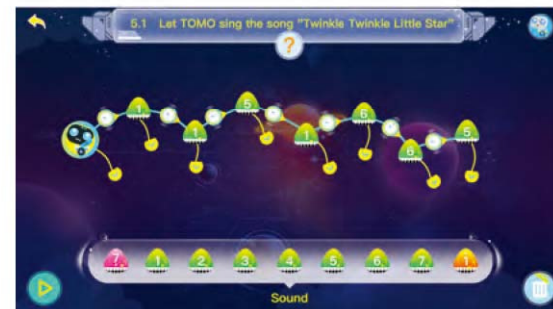
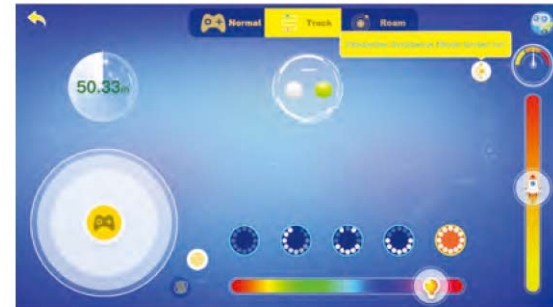

*Note: you can only use music/sound mode with Tricycle.*

## ● APP: ODEV Blockly

ODEV Blockly is an intermediate-advanced app using graphical programming as a tool to control Tomo. Children can create a small program by dragging and stacking all kinds of programming module blocks which will provide a directional path for Tomo. ODEV Blockly can enable children to learn programming and explore the full use of Tomo's directional and LED features. Please scan QR code to download the ODEV Blockly app in Apple App Store and Google Play.



Scan the QR to download  
ODEV Blockly

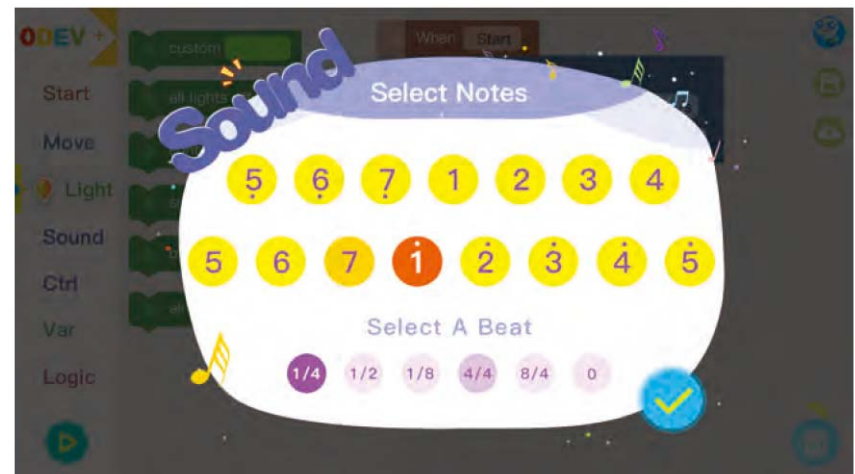
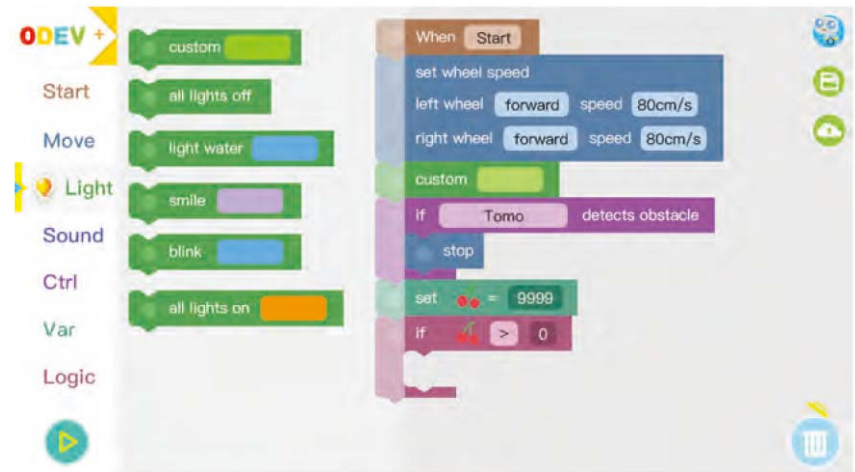

*Note: you can only use music/sound mode with Tricycle.*

## ● FAQ

### **Q: Why doesn't the robot respond after pressing the ON button?**

1. Check to see if the batteries were installed correctly.
2. Press and hold the ON button for 3 seconds to turn on the robot (you should hear a beep sound when the robot is on or off).
3. Make sure your phone or tablet has been connected to the robot via Bluetooth.

### **Q: Why does the robot move in the opposite direction from the control direction?**

1. Exchange the motor wire connectors to resolve this issue.

### **Q: Why is the Dicycle unbalanced or unresponsive?**

1. The power of battery may be low and needs to be replaced.
2. Make sure the motor wires are not touching the wheels. (you can use a tape to secure the wires.)
3. The operating mode on the ODEV Explorer app that is selected is wrong. Please make sure to choose Dicycle and connect it via bluetooth each time you open the app.
4. After successfully connecting Dicycle via Bluetooth, you must toggle Tomo upright for the auto balance feature to begin.

### **Q: My smartphone/tablet is unable to connect to Tomo. What can I do?**

1. Make sure the Bluetooth is enabled on your smartphone or tablet and keep it to a close proximity to Tomo.
2. Try restarting the app, and restart Tomo.

### **Q: Why is the screw coming loose?**

1. Due to the movement of Tomo, the screw may become loose during movement. It is crucial to ensure that all the screws are fastened tightly.

### **Q: Why is the tracking sensor not working properly?**

1. Do not use the tracking sensor under high exposure light.
2. The tracking sensor is installed above or below the recommended height.
3. Please check whether the wiring is connected correctly.



For more info about ODEV products, please scan the QR code to visit our website.  
[www.odevbot.com](http://www.odevbot.com)





Designed and Distributed By:  
**Tenergy Corporation**  
436 Kato Terrace, Fremont, CA 94539, USA

Designed and Manufactured By:  
Beijing Today Innovation Technology Co.,Ltd.  
No.118, Floor 1, Building 1, No.7, North Ritan Road,  
Chaoyang District, Beijing, PRC

Questions or comments?  
Please call us at 1 510-687-0388 or  
email us at [service@Tenergy.com](mailto:service@Tenergy.com)