

CA10™ CORDLESS ADAPTER

CA10™ DRAFT
REV-4 . 6/16/99

USER'S GUIDE

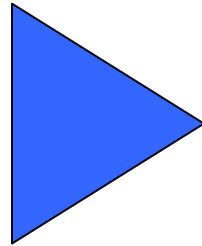

CONTENTS

Important safety instructions	3~4
Battery cautionary Instructions	5
Features	6
Introduction	7
Control location (Before you begin)	8~9
Diagram key.....	10
Installation and Operation	10
Setup.....	11
Placing a call	12
Receiving a call.....	12
Page function	12
Trouble shooting	13
Compatibility	13
I cannot hear a dial tone	13
Caller cannot hear my voice	13
I hear a buzz or hum	14
I can hear other cordless device users	14
Replacement	15
FCC Registration Information	16~17
Warranty and Service	18~19

IMPORTANT SAFETY INSTRUCTIONS

When using your telephone equipment, basic safety precautions should always be followed to reduce the risk of fire, electric shock, and injury to persons, including the following:

1. **Read and understand all instructions.**
2. **Follow all warnings and instructions marked on the product.** The symbol X identifies and alerts the user to the presence of important operating and service instructions.
3. **Unplug this product from the wall outlet before cleaning.** Do not use liquid cleaners or aerosol cleaners. Use a damp cloth for cleaning.
4. **Do not locate base unit near water,** for example, near a bathtub, wash bowl, kitchen sink, or laundry tub, in a wet basement or near a swimming pool.
5. **Do not place this product on an unstable cart, stand or table.** The product may fall, causing serious damage to the product.
6. **Slots and openings in the base unit and the bottom or back are provided for ventilation,** to protect it from overheating; these openings must not be blocked or covered. The openings should never be blocked by placing the product in the bed, sofa, rug or other similar surface. This product should never be placed near or over a radiator or heat register. This product not be placed in a built-in installation unless proper ventilation is provided.
7. **This product should be operated only from the type of power source indicated on the marking label.** If you are not sure of the type of power supply to your home, consult your dealer or local power company.
8. **Do not allow anything to rest on the power cord.** Do not locate this product where the cord will be abused by persons walking on it.
9. **Do not overload outlets and extension cords as this can result in the risk of fire or electric shock.**
10. **Never push objects of any kind into this product through base unit slots** as they may touch dangerous voltage points or short out parts that could result in a risk of fire or electric shock. Never spill liquid of any kind on the product.
11. **To reduce the risk of electric shock, do not disassemble this product,** but take it to qualified service personnel when service or repair work is required. Opening or removing covers may expose you to dangerous voltages or other risks. Incorrect reassembly can cause electric shock when the product is subsequently used.
12. **Avoid using a telephone equipment during an electrical storm.** There may be a remote risk of electric shock from lightning.
13. **Do not use the telephone equipment to report a gas leak in the vicinity of the leak.**
14. **Unplug this product from the wall outlet and refer servicing to qualified service personnel under the following conditions:**
 - a) When the power supply cord or plug is damaged or frayed.
 - b) If the product has been spilled into the product.
 - c) If the product has been exposed to rain or water.
 - d) If the product does not operate normally by following the operating instructions. Adjust only those controls that are covered by the operating instructions because improper adjustments of other controls may result in damage and will often require extensive work by a qualified technician to restore the product to normal operation.
 - e) If the product has been dropped or the base unit has been damaged.
 - f) If the product exhibits a distinct change in performance.
15. **Never install telephone wiring during a lightning storm.**

IMPORTANT SAFETY INSTRUCTIONS - CONTINUED

16. **Never install telephone jacks in wet locations** unless the jack is specifically designed for wet locations.
17. **Never touch uninsulated telephone wires or terminals** unless the telephone line has been disconnected at the network interface.
18. **Use caution when installing or modifying telephone lines.**
19. **Use only with class 2 power source.** Plantronics part No. 45689-01, rated at an input voltage of 120VAC, 60Hz and an output voltage of 500mA.
20. **This product requires AC power in order to operate. In order to have phone service during a power outage, have another telephone available that is powered only by the telephone line.**
21. **Keep all product cords and cables away from operating machinery.**

SAVE THESE INSTRUCTIONS

BATTERY CAUTIONARY INSTRUCTIONS

CAUTION : To reduce the risk of fire or injury to persons, read and follow these instructions.

1. Use only the replacement battery pack of the required size and type: 3.6 volt @ 720 mAh metal hydride battery, made by SANYO
2. Do not dispose of the batteries in a fire. The cell may explode. Check with local codes or possible special disposal instructions.
3. Do not open or mutilate the battery. Released electrolyte is corrosive and may cause damage to the eyes or skin. It may be toxic if swallowed.
4. Exercise care in handling batteries in order not to short the battery with conductors such as rings, bracelets, keys. The battery or conductor may overheat and cause burns.
5. Do not attempt to recharge the batteries provided with or identified for use with this product by heating them. The battery may leak corrosive electrolyte or may explode.
6. Do not attempt to rejuvenate the batteries provided with or identified for use with this product s by heating them. Suddenly release of the batteries electrolyte may occur causing burns or irritation to eyes or skin.
7. All batteries should be replaced at the same time. Mixing fresh and discharged batteries could increase internal cell pressure and and rupture the discharged batteries.
8. When inserting batteries into this product, the proper polarity or direction must be observed. Reverse insertion of batteries can cause charging, and that may result in leakage or explosion.
9. Remove the battery from this product if the product will not be used for a long period of time (several months or more) since during this time the battery could leak in the product.
10. Discard dead batteries as soon as possible since dead batteries are more likely to leak in a product.
11. Do not store this product, or the battery provided with or identified for use with this product, in high temperature areas . Batteries that are stored in a freezer or refrigerator for the purpose of extending shelf life should be protected from condensation during storage and defrosting. Batteries should be stabilized at room temperature prior to use after cold storage.

CAUTION  : Any changes or modifications in the construction of this device which is not expressly Approved by the party responsible for compliance could void the user's Authority to operate this equipment.

FEATURES

The CA10 Cordless Adapter is designed to provide the convenience of portable communication.

The CA10 Cordless Adapter consists of a cordless remote unit and a base unit which connects to your telephone. The base's space saving, upright design makes it ideal in areas where space is limited.

The CA10 unit allows the user to make/receive calls and then walk away from their desk. With the optional Handset Lifter you can receive calls even away from your desk.

A lightweight headset connected to the remote unit provides hands free communication, allowing the user to do other things while talking.

The CA10 Cordless Adapter offers the following features.

- Comfortable, lightweight headset, or specialty cable to support other Plantronics office headsets.
- Auto Scan, which automatically selects a clear channel between remote unit and base unit.
- Mute button turns off the headset microphone so that the other party cannot hear you.
- Channel button automatically selects the best of 40 available channels.
- Ringer ON/OFF switch allows user to turn off the remote ring when using handset lifter. (optional)
- Volume UP/DOWN button allows user to select proper audio receive level.
- Page button helps user to find the lost Remote unit.
- Configuration switches help support connectivity to most business phones.
- Manual channel setting to do radio frequency coordination in a dense office environment.
- Headset stand.
- Supports optional Handset Lifter or On-Line-Indicator accessories.
- User adjustable Transmit Volume setting on base unit.
- Replaceable and rechargeable NiMH battery clip.
- Hearing Aid Compatible.
- Up to 150 foot range, depending upon environment.
- Supplied with a Class 2 power adapter rated at 9V DC @800mA, center positive.

INTRODUCTION

WELCOME

Thank you for selecting CA10 Cordless Adapter from Plantronics. This User Guide Will help you install your CA10 Adapter and Learn its basic operation. The headset is described in a separate guide which should be read prior to installing the adapter.

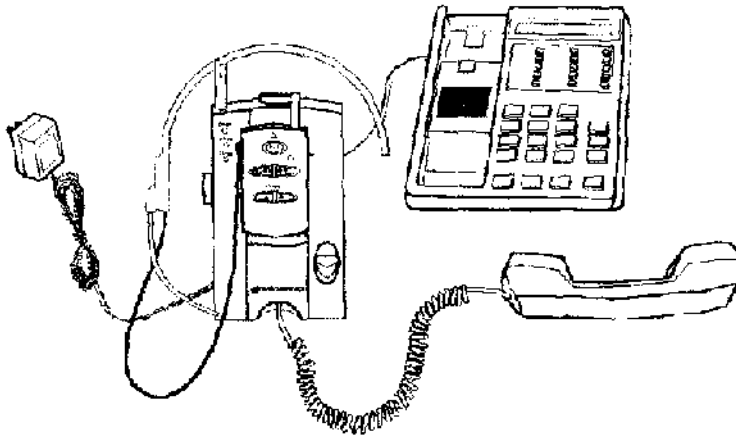

INTRODUCTION – CONTINUED

CONTROL LOCATION (Before you begin)

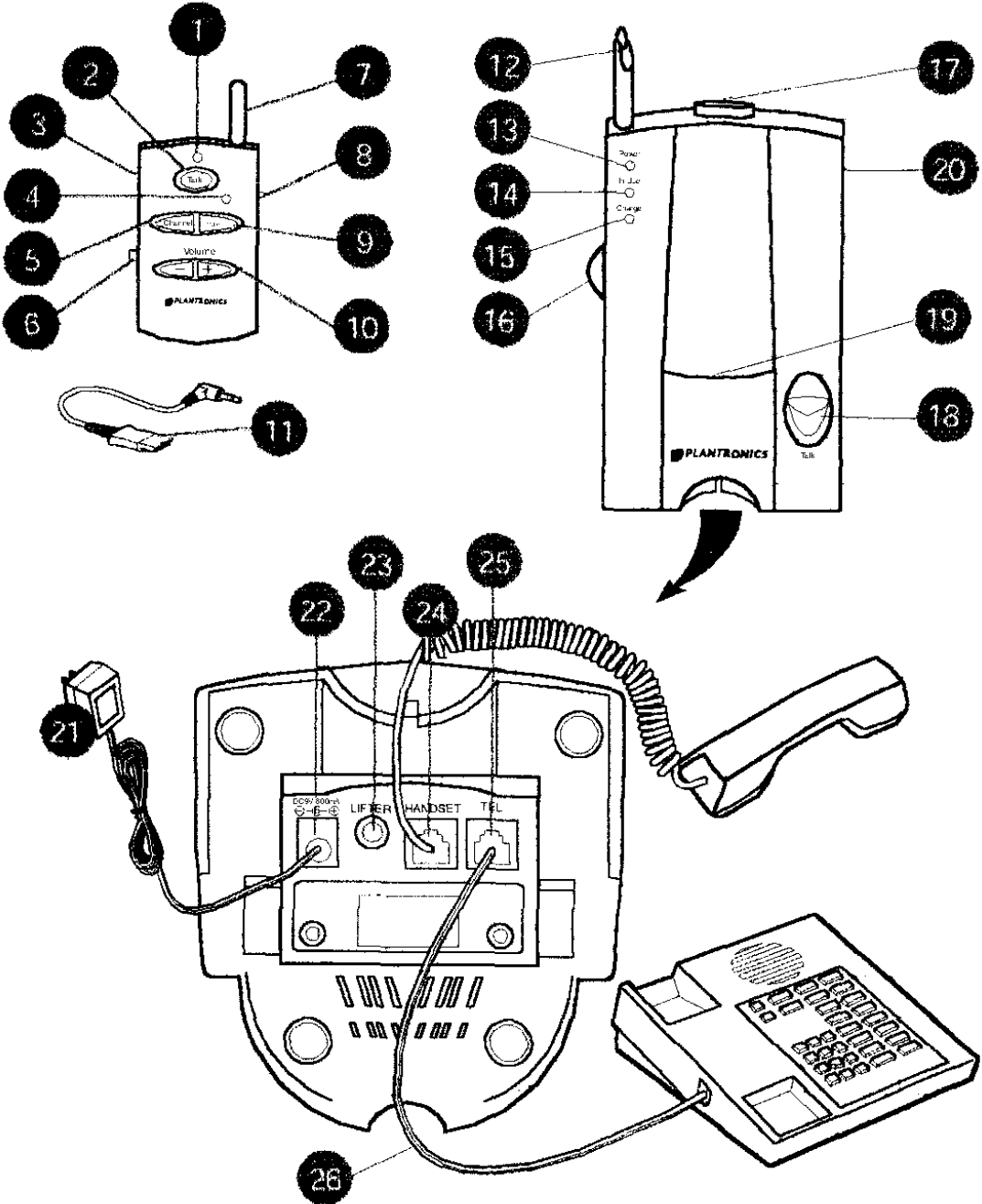

INTRODUCTION - CONTINUED

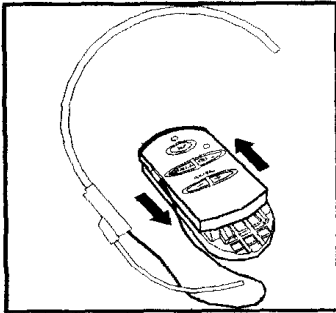

A

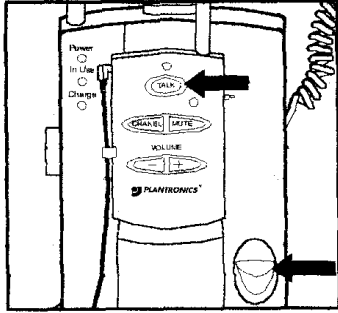

D

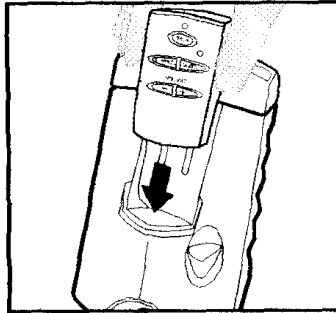

B

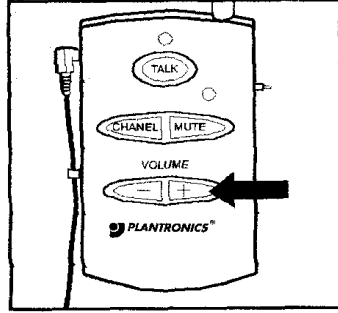

E

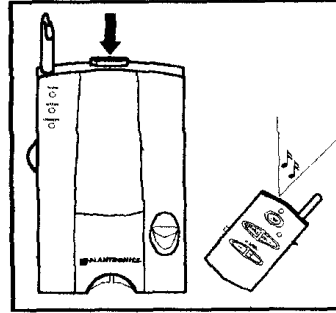

C

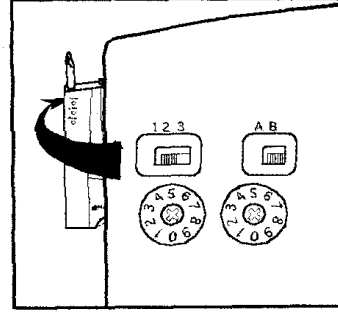

F

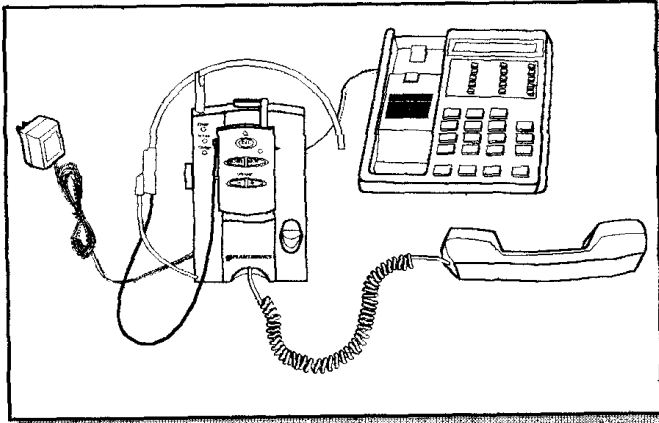

G

INTRODUCTION – CONTINUED

DIAGRAM KEY

REMOTE UNIT

- (1) In Use Indicator Light
- (2) Talk Button
- (3) Headset Jack
- (4) Mute Indicator Light
- (5) Channel Button
- (6) Cord Retainer
- (7) Antenna
- (8) Ringer ON/OFF
- (9) Mute Button
- (10) Listen Volume Control
- (11) Headset Adapter Cable
(P/N 43446-02) Optional
- (12) Headset Holder / Antenna

BASE UNIT

- (13) Power Light
 - (14) In Use Indicator Light
 - (15) Battery Charge Light
 - (16) Talk Volume Control
 - (17) Page Button
 - (18) Talk Button
 - (19) Charging Well
 - (20) Configuration Switches (not visible)
- Base Underside
- (21) AC Adapter
(P/N xxxxx-01)
 - (22) AC Adapter Jack
 - (23) Handset Lifter (Optional) Jack
 - (24) Handset Jack
 - (25) Telephone Jack

INSTALLATION AND OPERATION

SETUP

Connect the CA10 to your telephone using the illustrations on pages 8 and 9. G

Unplug the handset from your telephone's base and insert into the handset jack **(24)** on the underside of the CA10 Base Unit.

Using the short cord **(26)** provided, plug the CA10 into the Telephone Jack. **(25)**

Now connect the AC Power Supply **(21)** to the CA10 base **(22)** and into a wall outlet. The Power LED will light after connected, but the In-Use Indicator Light **(14)** will remain off.

Attach the Remote Unit to the Battery Pack. The Remote and Battery slip together easily and gently snap in place. Do not force. Connect your Headset to the Remote Unit. A
B

If you are using a headset whose cable terminates in a QD module, you will need the QD to 2.5mm Headset Adapter Cable (P/N 43446-02)

Gently slide the Remote Unit and Battery Pack into the Base Unit Charging Well **(19)** until the Battery Charge Light **(15)** is on (Charge indicator light on). Prior to first use, the Battery must charge for 8 hours. The Charge LED will turn off after the battery is fully charged. C

You are ready to make or receive calls.

Note :

Remote Unit must remain in the Base for 5-seconds to establish a communications link before the system can function. C

A single-beep indicates the Remote or Base Unit has been turned on.

A double-beep indicates the Remote Unit Battery is low.

INSTALLATION AND OPERATION – CONTINUED

PLACING A CALL

With your headset in position, place the handset off-hook.

Press the Talk Button on either the Remote (2) or the Base Unit. (18)

The In Use Indicator Lights (1)(14) on the Remote and Base Unit will light and you will hear a dial tone

G

D

If you do not hear a dial tone, see Troubleshooting on page x.

Dial a co-worker. When your answers, speak normally.

If your co-worker cannot hear you or you hear a buzz or hum, move the Configuration Switch to another setting.

F

Adjust how loud you sound to your co-worker by adjusting the Talk Volume Control. (16) Adjust the volume of your co-workers voice by using the Listen Volume Control. (10)

E

Replace the handset upon completion of the call and press either Talk button on the Remote (2) or the Base Unit (18) for two seconds. The In Use Indicator Lights (1)(14) will go out.

D

RECEIVING A CALL

With your headset in position, when your telephone notifies you of an incoming call, place the handset off-hook.

Press the Talk Button on the Remote (2) or the Base Unit (18) The In Use Indicator Lights (1)(14) will go on. Begin speaking.

D

Replace the handset upon completion of the call and press the Talk Button on the Remote (2) or the Base Unit (18) for two seconds. This In Use Indicator Lights (1)(14) will go out.

D

PAGE FUNCTION

If you have mislaid the Remote Unit or someone at the Base Unit needs to locate you, pressing the Page Button (17) causes the Remote to emit a long, loud beep.

C

TROUBLE SHOOTING

COMPATIBILITY

Most often the CA10 Adapter will operate properly with the Configuration Switches (20) set, A-1. If when connected to the host telephone, your CA10 does not perform optimally at this setting, try one of the alternate settings shown below. Use the Talk volume Control (16) to fine tune the setting.

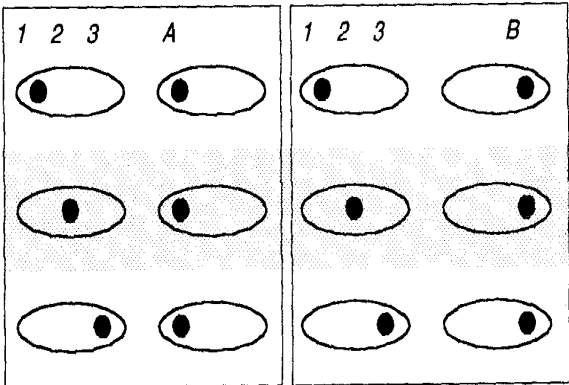

I CANNOT HEAR A DIAL TONE

Make sure your Remote Battery Pack is charged. Must Charge for 8 Hours prior to first use.

Check that all cords are correctly connected and firmly in place. Adjust the listen Volume Control (10).

Make sure the Remote Unit is within 50 feet of the Base unit.

Make sure the handset is off-hook.

Return the remote to the Base Unit charger for 5 seconds to establish a new security code.

Change the Configuration Switches (20) as described on page x.

CALLER CANNOT HEAR MY VOICE

Make sure the Mute Button is off. (9)

Adjust the Talk Volume Control. (16)

Adjust headset so the voice boom is closer to your mouth.

TROUBLE SHOOTING– CONTINUED

I HEAR A BUZZ OR HUM

Change the Configuration Switches (20) as described on page 8.

Try locating your Base Unit in different positions and make sure no objects obstruct the Remote or Base Unit.

Locate the Remote and Base Units away from electronic equipment or other radio-frequency devices.

I CAN HEAR OTHER CORDLESS DEVICE USERS

Press the Channel Button (5) until you set a clear signal.

If others are using a CA10 in your immediate vicinity, call Plantronics for instructions on adjusting the range control settings.

TROUBLE SHOOTING– CONTINUED

REPLACEMENT

PARTS & ACCESSORIES

Battery Pack (P / N xxxxxx-01)



Lifter (P / N xxxxxx-01) image to come
Automatically places handset off-hook.

Remote (P / N xxxxxx-01)



Short Cord (P / N xxxxxx-01)

FCC REGISTRATION INFORMATION

FCC REQUIREMENTS – PART 15

NOTE : This device complies with Part 15 of the FCC Rules.
Operation is subject to the following two conditions;

1. This device may not cause harmful interference, and
 2. This device must accept any interference received, including interference that may cause undesired operation.
- Privacy of communication may not be ensured when using this phone.

This equipment has been tested and found to comply with the limits for a Class B digital device, pursuant to Part 15 of the FCC Rules. These limits are designed to provide reasonable protection against harmful interference in a residential installation. This equipment generates, uses, and can radiate radio frequency energy and, if not installed and used in accordance with the instructions, may cause harmful interference to radio communications.

However, there is no guarantee that interference will not occur in a particular installation. If this equipment does cause harmful interference to radio or television reception, which can be determined by turning the radio or television off and on, the user is encouraged to try to correct interference by one or more of the following measures:

1. Reorient or relocate the receiving antenna.
2. Increase the separation between the equipment and receiver.
3. Connect the equipment into an outlet on another circuit.
4. Consult the dealer or an experienced radio / TV technician for help.

FCC REQUIREMENTS – PART 68

This equipment complies with Part 68 of the FCC rules. On the bottom of the modular adapter is a label that contains, among other information, the FCC registration number and ringer equivalence number (REN) for this equipment. If requested, this information must be provided to the telephone company.

The telephone company may make changes in its facilities, equipment, operation or procedures that could affect the operation of the equipment. If this happens, the telephone company should provide you advance notice in order for you to make the necessary modifications to maintain uninterrupted services.

If you experience problems with your headset, please refer to the warranty section for information on warranty and repair service. If the problem is causing harm to the telephone network, the telephone company may request that you remove the equipment until the problem is resolved. In extreme cases, the telephone company may be forced to disconnect your service before notifying you of the problem.

FCC REGISTRATION INFORMATION – CONTINUED

HEARING AID COMPATIBILITY INFORMATION

This telephone is not compatible with inductively coupled hearing aids.

FCC rules prohibit the use of non-hearing aid-compatible telephones in the following locations or applications;

1. All public or semipublic coin-operated or credit card telephones.
2. Elevators, highways and tunnels (automobile, subway, railroad or pedestrian) where a person with impaired might be isolated in an emergency.
3. Places where telephones are specifically installed to alert emergency authorities such as fire, police or medical assistance personnel.
4. Hospital rooms, residential health care facilities, convalescent homes and prisons.
5. Workstations for hearing impaired personnel.
6. Hotel, motel, apartment lobbies, and stores where telephones are used by patrons to order merchandise, in public transportation terminals where telephones are used to call taxis or to reserve lodging or rental automobiles.
7. Hotel and motel rooms. (At least ten percent of the rooms must contain hearing aid-compatible telephones, or jacks for plug-in hearing aid –compatible telephones which will be provided to hearing-impaired customers upon request).

WARRANTY AND SERVICE

The following warranty and service information applies only to the U.S. and Canada.
For information in other countries, please contact your local distributor.

To obtain in or out of warranty service, please prepay shipment and return the unit to the appropriate facility listed below;

IN THE UNITED STATES

**Plantronics Service Center
345 Encinal Street
Santa Cruz, CA95060**

**Tel. (800) 544-4660
(831) 458-7700
Fax (800) 279-0162**

IN CANADA

**Plantronics Service Center
1455 Pitfield Blvd.
Saint-Laurent, Quebec H4S1G3**

**Tel. (800) 956-8363
(514) 956-8363
Fax (514) 956-1825**

Please use the original container, or pack the unit(s) in a sturdy carton with sufficient packing material to prevent damage. Include the following information;

1. A proof- of – purchase indicating model number and date of purchase.
2. Bill-to address
3. Ship-to address
4. Number and description of units shipped
5. Name and telephone number of person to call, should contact be necessary
6. Reason for return and description of the problem

Damage occurring during shipment is deemed the responsibility of the carrier, and claims should be made directly with the carrier.

345 ENCINAL STREET SANTA CRUZ, CA 95060 800.544.4660
www.plantronics.com



Printed in the U.S.A.

P/N © 6•99