



## PM2420 TABLE OF CONTENTS

IMPORTANT SAFETY INSTRUCTIONS .....	1
FCC REGULATIONS .....	3
IC REGULATIONS .....	5
BATTERY CAUTIONARY INSTRUCTIONS .....	6
PM2420 PARTS CHECKLIST .....	7
CONTROLS AND FEATURES .....	8
CHOOSING A LOCATION .....	12
TELEPHONE SET-UP .....	13
BATTERY INSTALLATION .....	15
HEADSET AND BELT CLIP .....	16
BASIC OPERATION .....	17
SETTINGS .....	18
SPEED DIALING .....	24
CALLER ID .....	29
OTHER FEATURES .....	33
CARE AND MAINTENANCE .....	34
TROUBLE SHOOTING .....	35
GLOSSARY .....	37
WARRANTY STATEMENT .....	38

Thank you for purchasing this PhoneMate Telephone.  
Please read this manual carefully prior to using.

PhoneMate and the PhoneMate Logo are registered trademarks of PhoneMate Corporation and are used under license from PhoneMate Corporation.

## IMPORTANT SAFETY INSTRUCTIONS



!! Always follow basic safety precautions when using this product to reduce the risk of injury, fire, or electrical shock.

**When using this product, basic precautions should always be followed to reduce the risk of fire, electric shock and injury to persons, including the following:**

1. Read and understand all instructions
2. Follow all warnings and instructions marked on the product.
3. Use only with class 2 power source DC 9V 300mA.
4. Unplug this product from the wall outlet before cleaning. Do not use liquid cleaners or aerosol cleaners. Use a damp cloth for cleaning.
5. Do not use this product near water; for example, near a bathtub, wash bowl, kitchen sink, or laundry tub, in a wet basement or near a swimming pool.
6. Do not place this product on an unstable cart, stand, or table. The product may fall causing serious damage to the product.
7. Slots and openings in the cabinet back or bottom are provided for ventilation. To protect it from overheating, these openings must not be blocked or covered. The openings should never be blocked by placing the product on the bed, sofa, rug, or other similar surface. This product should never be placed near or over a radiator or heat register. This product should not be placed in an enclosed environment unless proper ventilation is provided.
8. Do not allow anything to rest on the power cord. Do not locate this product where the cord will be abused by animals or persons walking on it.
9. Do not overload wall outlets and extension cords as this can result in risk of fire or electrical shock.
10. Never push objects of any kind into this product through cabinets slots as they may touch dangerous voltage points or short out parts that could result in a risk of fire or electrical shock. Never spill liquid of any kind on the product.
11. To reduce the risk of electrical shock, do not disassemble this product. Instead take it to a qualified service person when service or repair work is required. Opening or removing covers may expose you to dangerous voltages or other risks. Incorrect re-assembly can cause electrical shock when the appliance is subsequently used.
12. Unplug all cords and refer servicing to qualified service personnel under the following conditions:
  - i When the power supply cord or plug is damaged or frayed
  - ii If liquid has been spilled into the product.
  - iii If the product has been exposed to rain or water.
  - iv If the product does not operate normally by following the operating instructions, adjust only those controls covered in the operating instructions. Improper

## IMPORTANT SAFETY INSTRUCTIONS

adjustment of other controls may result in damage and require work by a qualified technician to restore the product to normal operation.

13. Avoid using a telephone (other than a cordless type) during an electrical storm. There maybe a remote risk of electric shock from lightning.
14. Do not use a telephone to report a gas leak in the vicinity of the leak.

IF YOUR PRODUCT UTILIZES BATTERIES, THE FOLLOWING ADDITIONAL PRECAUTIONS SHOULD BE OBSERVED:

1. Use only the type and size of batteries specified in the users manual.
2. Do not dispose of batteries in a fire. The cells may explode. Check with local codes for possible special disposal instructions.
3. Do not open or mutilate the batteries. Released electrolyte is corrosive and may cause damage to the eyes or skin. It maybe toxic if swallowed.
4. Exercise care in handling batteries in order not to short the battery with conducting materials such as rings, bracelets and keys. The battery or conductor may overheat and cause burns.
5. Do not attempt to recharge the batteries with or identified for use for use with this product. The batteries may leak corrosive electrolyte or explode.
6. Do not attempt to rejuvenate the batteries provided with or identified for use with this product by heating them. Sudden release of the battery electrolyte may occur causing burns or irritation to eyes or skin.
7. When replacing batteries, all batteries should be replaced at the same time. Mixing fresh and discharged batteries could increase internal cell pressure and rupture the discharged batteries.
8. When inserting the batteries into this product, the proper polarity or direction must be observed. Reverse insertion of the batteries can cause charging, which may result in leakage or explosion. If a batter is installed incorrectly it may explode.
9. Remove the batteries from this product if the product will not be used for a long period of time (several months or more) since during this time the batteries could leak, damaging the product.
10. Discard "dead" batteries as soon as possible since they are more likely to leak in a product.
11. Do not store this product, or the batteries provided with or identified for use with this product, in high temperature areas.
12. If your product uses a rechargeable battery, charge the battery (ies) only in accordance with the instructions and limitation specified in the User Manual.
13. Plug the adaptor to the socket-outlet that is nearest to the equipment and shall be easily accessible.

**SAVE THESE INSTRUCTIONS**

## FCC REGULATIONS

**WARNING: Changes or modifications to this unit not expressly approved by the party responsible for compliance could void the user's authority to operate the equipment.**

1. This equipment complies with Part 68 of the FCC rules and the requirements adopted by the ACTA. On the bottom of this equipment is a label that contains, among other information, a product identifier in the format US : AAAEQ##TXXXX. If requested, this number must be provided to the telephone company.
2. The USOC number of the registration jack for the equipment is RJ11C.
3. A FCC compliant telephone cord and modular plug is provided with this equipment. This equipment is designed to be connected to the telephone network or premises wiring using a compatible modular jack which is Part 68 compliant. See Installation Instructions for details.
4. The REN is used to determine the quantity of devices which may be connected to the telephone line. Excessive RENs on the telephone line may result in the devices not ringing in response to an incoming call. In most, but not all areas, the sum of RENs should not exceed five (5.0). To be certain of the number of devices that may be connected to a line, as determined by the total RENs, contact the local telephone company.
5. If this terminal equipment causes harm to the telephone network, the telephone company will notify you in advance that temporary discontinuance of service may be required. But if advance notice isn't practical, the telephone company will notify the customer as soon as possible. Also, you will be advised of your right to file a complaint with the FCC if you believe it is unnecessary.
6. The telephone company may make changes in its facilities, equipment, operations or procedures that could affect the operation of the equipment. If this happens the telephone company will provide advance notice in order for you to make necessary modifications to maintain uninterrupted services.
7. The equipment cannot be used on public coin phone service provided by the telephone company. Connection to party line service is subject to state tariffs.
8. Please follow all instructions when replacing any parts (e.g. battery replacement section), otherwise do not attempt to alternate or repair any parts of the device except those specified.
9. This equipment, if it uses a telephone handset is hearing aid compatible.
10. If trouble is experienced with this equipment, for repair or warranty information, please contact the service center below. If the equipment is causing harm to the telephone network, the telephone company may request that you disconnect the equipment until the problem is resolved.

## FCC REGULATIONS

Service can be obtained at:

PhoneMate Service Center  
14515 Valley View Ave. #B  
Santa Fe Springs, CA  
90670

### INTERFERENCE INFORMATION: PART 15 OF FCC RULES

Some telephone equipment generates and uses radio frequency energy, which if not properly installed, may cause interference to radio and television reception.

This unit has been tested and found to comply with the limits for a Class B computing device in accordance with the specifications in Part 15 of the FCC rules. These specifications are designed to provide reasonable protection against such interference in a residential installation.

If this equipment does cause interference to radio or television reception, when it's in use, the user is encouraged to try to correct the interference by one or more of the following measures:

- A. Where it can be done safely, reorient the radio or TV receiving antenna.
- B. To the extent possible, relocate the television, radio, or other receiver with respect to the telephone equipment.
- C. If your telephone products run on AC power, plug your product into an AC outlet that's not on the same circuit as the one used by the radio or television.

**NOTICE :** If your home has a wired alarm equipment system connected to the telephone line, ensure the installation of this PM2420 does not disable your alarm equipment. If you have questions about what will disable the alarm equipment, consult your telephone company or a qualified installer.

This device complies with Part 15 of the FCC rules. Operation is subject to the following two conditions : (1) This device may not cause harmful interference, and (2) This device must accept any interference received, including interference that may cause undesired operation. Privacy of communications may not be ensured when using this phone.

## IC REGULATIONS

Model PM2420

**Notice :** This equipment meets the applicable Industry Canada Terminal Equipment Technical Specifications. This is confirmed by the registration number. The abbreviation, IC, before the registration number signifies that registration was performed based on a Declaration of Conformity indicating that Industry Canada technical specifications were met. It does not imply that Industry Canada approved the equipment.

Before installing this equipment, users should ensure that it is permissible to be connected to the facilities of the local telecommunications company. The equipment must also be installed using an acceptable method of connection. The customer should be aware that compliance with the above conditions may not prevent degradation of service in some situations.

Repairs to certified equipment should be coordinated by a representative designated by the supplier. Any repairs or alterations made by the user to this equipment, or equipment malfunctions, may give the telecommunications company cause to request the user to disconnect the equipment.

Users should ensure for their own protection that the electrical ground connections of the power utility, telephone lines and internal metallic water pipe system, if present, are connected together. This precaution may be particularly important in rural areas.

**Caution:** Users should not attempt to make such connections themselves, but should contact the appropriate electric inspection authority, or electrician, as appropriate.

**Notice:** The Ringer Equivalence Number (**REN**) assigned to each terminal device provides an indication of the maximum number of terminals allowed to be connected to a telephone interface. The termination on any interface may consist of Ringer Equivalence Numbers of all the device does not exceed 5.

Privacy of communications may not be ensured when using this telephone.

### Interference Information

**Operation is subject to the following two conditions:** (1) this device may not cause interference, and (2) this device must accept any interference, including interference that may cause undesired operation of the device.

## BATTERY CAUTIONARY INSTRUCTIONS

### CAUTION :

**Risk of explosion if battery is replaced by an incorrect type. Dispose of used batteries according to the instructions:**

- 9 For the cordless handset, use only 3.6V 400mAh Nickel-Cadmium (Ni-CD), SN05-AS003-215 made by SANIK BATTERY CO.,Ltd, cordless telephone battery pack. (included).
- 9 Do not dispose of the batteries in a fire. The cells may explode. Check with local codes for possible special disposal instructions.
- 9 Do not open or mutilate the batteries. Released electrolyte is corrosive and may cause damage to the eyes or skin. It may be toxic if swallowed.
- 9 Exercise care in handling batteries in order not to short the battery with conducting materials such as rings, bracelets, and keys. The battery or conductor may overheat and cause burns.
- 9 Do not attempt to rejuvenate the batteries identified for use with this product by heating them. Sudden release of the battery electrolyte may occur causing burns or irritation to eyes or skin.
- 9 When inserting batteries into this product, the proper polarity or direction must be observed. Reverse insertion of batteries can cause charging, and that may result in leakage or explosion.
- 9 Remove the batteries from this product if the product will not be used for a long period of time (several months or more) since during this time the battery could leak in the product.
- 9 Do not store this product, or the batteries identified for use with this product, in high temperature areas. Batteries that are stored in a freezer or refrigerator for the purpose of extending shelf life should be protected from condensation during storage and defrosting.

Batteries should be stabilized at room temperature prior to use after cold storage.

## PM2420 PARTS CHECKLIST

- 1 Handset
- 2 Base
- 3 AC power adapter
- 4 Cord for desk use
- 5 Belt Clip
- 6 Ni-CD battery pack

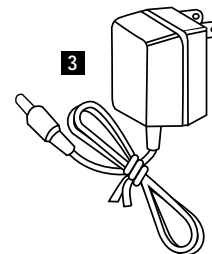
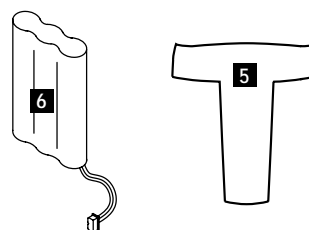
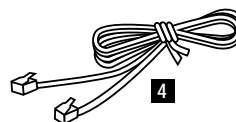
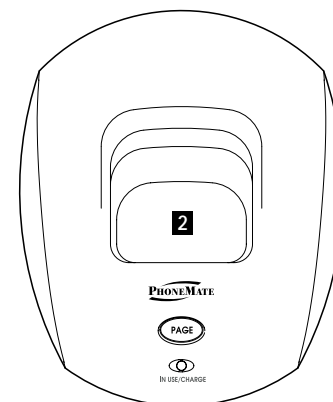

## CONTROLS AND FEATURES

- 1** Talk  
The **Talk** is used to access the telephone line or end a call.
- 2** Caller ID Key (CID)  
The **Caller ID** key is used to recall and review the **Caller ID** information stored in Memory. The PM2420 stores up to 40 Names and Numbers.
- 3** Redial Key (REDIAL/DELETE)  
When the phone is off-hook, press Redial key to redial the last number dialed. The **REDIAL/DELETE** key is also used to erase digits and single or multiple entries in the PhoneBook and Caller ID log. Redial is also used to insert a measured pause into a number stored in the phone book.
- 4** Channel Key (CH)  
The **CH** key, if pressed when the line is off-hook, will scan up to 40 channels and select the clearest one to provide the best possible reception.
- 5** MUTE/PROG Key  
The **Mute/Prog** key is used to temporarily mute the handset microphone. It is also used to access the programmable functions of your telephone.
- 6** Dial Pad  
Numeric keys are used in the conventional manner for dialing.
- 7** FLASH/EDIT Key  
The **Flash** key is used to access telephone company services, such as call waiting. It is also used to enter or edit entries in the Phone Book.

- 8** MEM/SAVE Key  
Use the **MEM/SAVE** key to program and retrieve the numbers in the speed dial directory. The **MEM/SAVE** key is also used to save other programmable settings as well as store numbers into the Phone Book.
- 9** Temporary Tone/View Left Key  
If the base is set to pulse dialing, pressing **⬅ \* ⬅** causes subsequent digits to be dialed out using tone until the line is put back on hook. It is also used to scroll the left part of the display and move the cursor left when editing or programming.

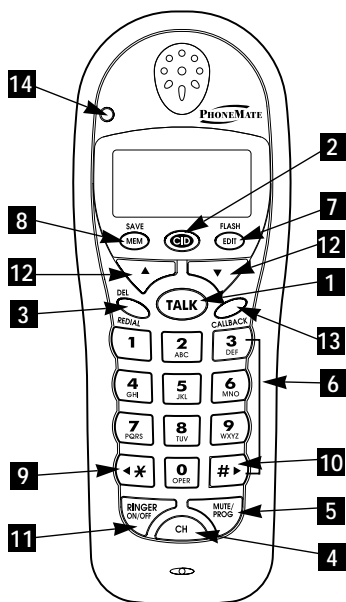

## CONTROLS AND FEATURES

- 10** View Right Key  
The View Right Key **[# ▶]** is used to scroll the right part of the display as well as move the cursor right when editing or programming.
- 11** Ringer Switch  
The **RINGER** switch is used to adjust the handset ringer level between **Off, On**.
- 12** VOL/SCROLL  
The **▼▲** key allows you to scroll through the logs and menus as well as adjust the handset volume.
- 13** CALL BACK KEY  
Used for changing from 10 to 11 digit dialing.
- 14** New Call Indicator  
When there are new calls that have not been reviewed on the **Caller ID** display, this Indicator will flash. If you subscribe to any Voice Mail service that maybe offered by your local Telephone company, it will also flash when there are new messages that you have not heard.

## CONTROLS AND FEATURES

### BASE

- 1** Page  
Used to initiate a handset page.
- 2** IN USE/CHARGE LED  
On (red) when the handset is on the cradle being charged or when the handset is in use. On if the line is in use.
- 3** Charging Contacts  
Used to recharge battery and reset the security code in the handset.
- 4** Tone/Pulse Switch  
Used to set the dialing method for tone or pulse dialing. It is located at the bottom of the base unit.

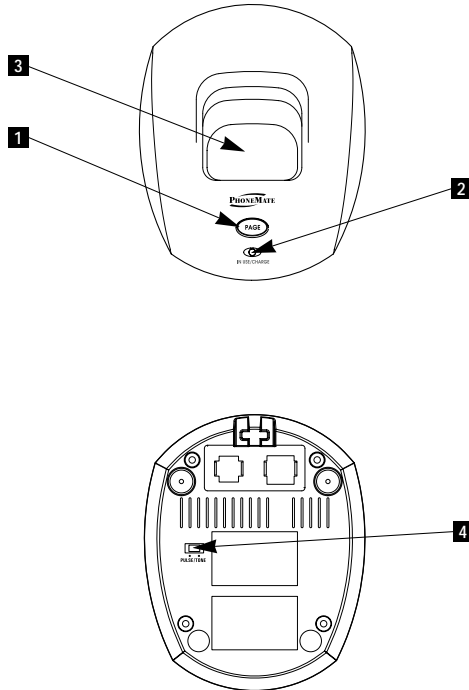

## CONTROLS AND FEATURES

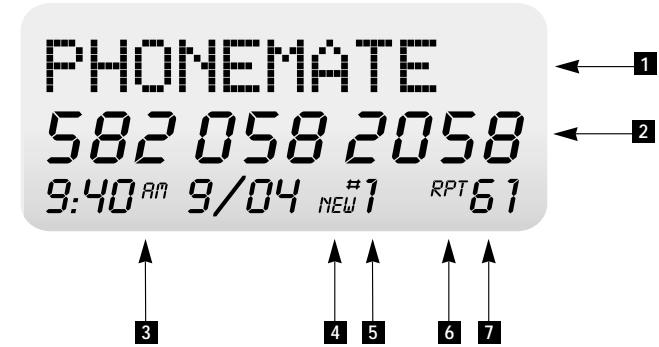

### LCD DISPLAY

- 1** Name Character Field  
Displays the Caller's name as well as various operational menus.
- 2** Number Field  
Displays the Caller's phone number, as well as the numbers in your Phone Book and the numbers you are dialing.
- 3** Date/Time Display  
Displays the date and time of the calls from the Caller ID log, as well as the current date and time when the phone is not in use.
- 4** New Icon  
When the phone is not in use, and a new Caller ID has been received, this icon will flash slowly. Beside this icon the number of new calls in the Caller ID log will be displayed.
- 5** Call/Entry Number  
This indicates the position of the call in the Caller ID log and/or the position of a particular entry in the Phone Book.
- 6** RPT Counter  
This identifies repeat callers in the Caller ID log, since the Caller ID log was last reviewed. Beside the RPT icon is a counter that indicates how many times that caller has called.
- 7** Total Call Counter  
Depending on the menu being used, the Total Call Counter will indicate the total number of calls in the Caller ID log or the total number of entries in the Phone Book.

## CHOOSING A LOCATION

When installing your telephone, consider the following:

The best location:

- Near a central location on a level dry surface.
- Away from microwave ovens
- Away from VCR's and TV sets and other electronic equipment
- Away from sources of noise, such as windows opening onto a busy street
- Away from personal computers
- Away from excessive moisture, extremely low or extremely high temperatures, dust, mechanical vibration or shock.

The location of your telephone affects the quality of the reception. Consider the following when choosing a location or if you are experiencing poor reception.

- Away from other cordless telephones
- Place the base near an AC electrical outlet and near a telephone line jack
- Place the base away from metal walls and metal file cabinets.
- Try to avoid power bars or multiple appliances plugged into the same electrical outlet

**CAUTION:** The cordless telephone operates at a frequency that may cause interference to nearby TV's and VCR's; the base phone should not be placed near, or on top of a TV or VCR. If interference is experienced, moving the cordless phone telephone farther away from the TV or VCR will often reduce or eliminate the interference.

## TELEPHONE SETUP

Connecting the Base

1. Connect the telephone line cord to the "TEL LINE" jack and to a telephone outlet.
2. Connect the AC power adapter to the 9V DC jack and to an AC outlet.

**Note:** : Use only the supplied AC power adapter. Do not use any other AC power adapter. Connect the AC power adapter to a continuous power supply. Place the phone close to the AC outlet so that you can plug in the AC power adapter easily.

**TIP:** If your telephone outlet is not modular, contact your telephone company for assistance.

Tone/Pulse Switch

1. Choose the correct dialing mode.
2. Select the dialing mode Tone or Pulse by setting the switch at the bottom of the base unit.

**Note:** Changes to the switch position during a call do not take effect until the call has ended.

**TIP:** If you are unsure of the proper dialing mode, make a trial call with the dial mode setting to TONE. If the call connects, leave the switch as is (TONE mode), otherwise, set to PULSE.

Handset Ringer Switch

Adjust the handset ringer volume using the **RINGER** switch on the right side of the handset. Select between ringer **On**, or ringer **Off**.

## BATTERY INSTALLATION

To install the 3.6V 400mAh cordless handset battery pack:

1. Slide open the battery compartment door on the back of the handset.
2. Plug the battery connector into the 2-pin connector in the battery compartment, and then insert the battery.
3. Close the battery compartment door.
4. Place the handset on the base unit cradle.
5. Once you have installed the battery pack and placed the handset on the base you will hear a tone indicating the handset has connected with the base and will successfully charge.
6. **IMPORTANT:** Charge the battery pack for at least 12 hours before using the handset the first time.
7. The **CHARGE LED** on the base illuminates when the handset is properly making contact with the charge terminals.

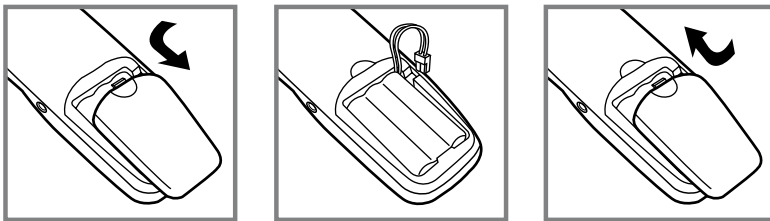

### Battery Duration

A fully charged battery lasts for approximately:

- 3 hours when you use the handset continuously (talk time).
- 3 days when the handset is not in use (standby).



When the Battery Needs Charging  
 The display will indicate "LOW BATTERY"

## HEADSET AND BELT-CLIP

Model PM2420

### 1 The Headset Jack

The headset jack is located on the side of the handset and is a standard 2.5 mm plug. Simply plug the headset (not included) into the jack and the headset will be active.

**Note:** When the headset is plugged into the telephone, the microphone and earpiece on the handset are not active.

### 2 Belt Clip

The Belt-Clip is inserted on the back of the handset, directly behind the earpiece. Simply click the sides of the belt-clip onto the slots on either side of the handset, beside the earpiece.

To remove the belt-clip, gently pry one side of the belt-clip away from the handset and the belt-clip will slide off. Bending the belt-clip too much could damage the belt-clip.

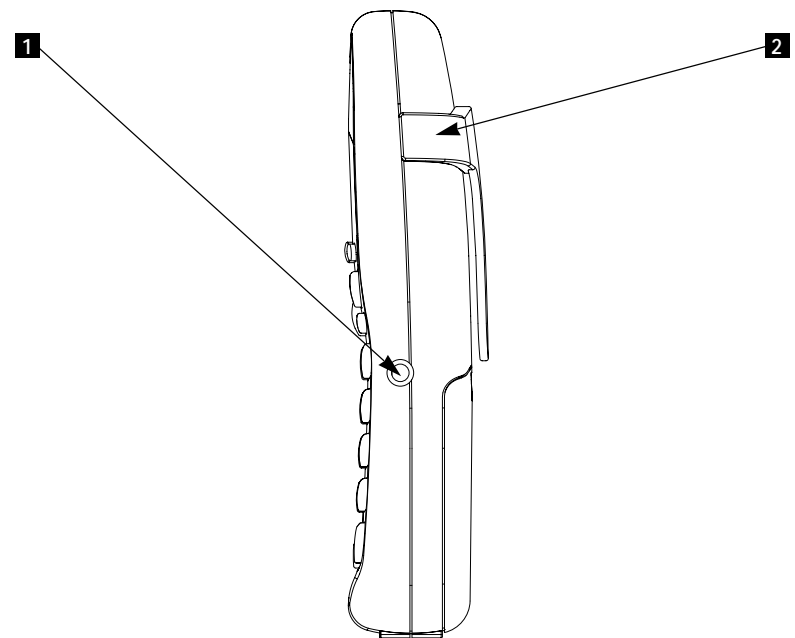





## BASIC OPERATION

### Making Calls

1. Pick up the handset from the base and press **Talk**. The LCD will display "TALK" while the handset is scanning for a clear channel.
2. Once you hear a dial tone, dial the number you wish to dial.
3. When you are finished talking, press the **Talk** key or place the unit back into the base to end the call.



### Receiving Calls

#### When you hear the phone ring:

1. If the handset is in the base, lift the handset from the base and press the **Talk** key to answer the call. The "Auto-Answer" feature has a factory setting of **OFF**. To set the "Auto-Answer" feature to **ON**, refer to the "Auto-Answer" section in "SETTINGS".
2. If the handset is off the base, you will need to press **Talk** to answer the call.
3. When you are finished, push **Talk** or place the handset back on the base.

### Redialing

1. Lift the handset from the base and press "TALK"
2. Wait until you hear the dial tone.
3. Press "REDIAL" to dial the last number that called (up to 32 digits)

### Additional Options

TO	DO THIS
Receive a Call Waiting Call	Press <b>FLASH</b> to answer the new call that is waiting. Press <b>FLASH</b> again to return to the first call.
Redial the last number	Press <b>Talk</b> . Wait for dial tone and then press <b>Redial</b> .
Adjust the volume in the earpiece	Press the Volume switch <b>▼▲</b> during a call until the desired volume level is reached.
Switch to temporary tone dialing	Press the <b>▼*</b> key after the phone is in use. The phone will remain in tone dialing mode for the duration of the call.
Mute a call	Press the <b>Mute</b> key. Press <b>Mute</b> again to continue speaking to the caller

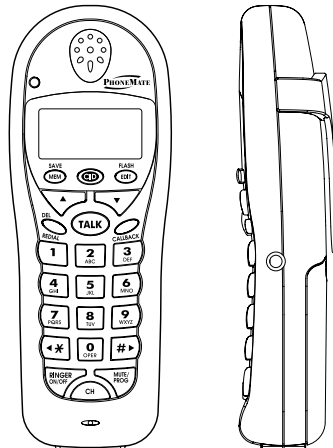

## SETTINGS

### Handset Settings

There are 11 different settings in the options menu which are accessed on the handset by pressing and holding the **MUTE/PROG** key. To access the different functions that can be programmed use the **▼▲** key to scroll through the various functions. If the function is also identified with a number, you can access that function by pressing the corresponding number on the keypad.

For most functions, press the **FLASH/EDIT** key and use the scroll keys **▼▲** to view the various settings that are available. Once you have selected the desired setting press the **MEM/SAVE** button to save the changes.

When you have finished programming, press the **MUTE/PROG** button to exit the options menu.

#### KEY FUNCTION

- 1 **Language:** The PM2420 can operate in three different languages. English, French and Spanish. Use the scroll keys to select the language you wish to use and press **MEM/SAVE**.
- 2 **First Ring On/Off:** With this feature, you can program the phone to not ring until the Caller ID information has appeared on the display. This is helpful when using the Priority and Blocked Call features or the Private and Unavailable ring settings.
- 3 **Time Set:** Changes the time and date.
- 4 **Contrast:** Adjusts the contrast or brightness of the display to improve viewing.
- 5 **PBX Number:** This selects the number used to access **PBX** dialing options. The factory default setting is "9".
- 6 **PBX Mode On/Off:** When operating within a **PBX** system and dialing a number from the Caller ID log or Phone Book, the **PBX** number and the required pause after is automatically dialed. The factory default setting is "Off".
- 7 **Pause Time:** Adjusts the number of seconds that a programmed pause will last when programming pauses in your Phone Book or Speed Dial. For example when a pause is required between dialing "9" and the phone number when operating in a **PBX** system.
- 8 **MSG Waiting Delete:** Deletes any current message waiting indication.
- 9 **Unavailable Ring On/Off:** When set to "Off", if there is no Caller ID information available, the phone will not ring. Note: The phone will ring once even when set to "Off" unless the "First Ring" feature is also set to "Off".
- 0 **Private Ring On/Off:** When set to "Off" the phone will not ring for all calls where the caller has blocked their Caller ID. Note: The phone will ring once even when set to "Off" unless the "First Ring" feature is also set to "Off".
- \* **Auto-Answer On/Off:** The PM2420 comes with a factory default setting of "Off". When set to "On" the call is automatically answered as soon as the handset is lifted out of the base.

## SETTINGS

## Changing the Language

1. Press and hold the **MUTE/PROG** key.
2. Press **1** to access the language option.



3. Press the **FLASH/EDIT** button to change the setting. "ENGLISH" will begin flashing.
4. Use the scroll keys **▼▲** to change between ENGLISH, ESPANOL, and FRANCAIS.
5. When the setting you want appears, press **MEM/SAVE** to save the selection. A double beep will be heard to confirm the selection has been saved.
6. Press **MUTE/PROG** to exit, or continue programming other settings.

## Turning the First Ring On or Off

Allows you to turn the first ring off, so that the phone does not ring until the Caller ID information is displayed.

1. Press and hold the **MUTE/PROG** key.
2. Press **"2"** to access the First Ring option.



3. Press **FLASH/EDIT** button to change the setting. "On" will flash in the display.
4. Using the scroll keys **▼▲** keys, choose either **On** or **Off**.
5. Once you have selected the setting, press the **MEM/SAVE** button to save the selection. A double beep will be heard to confirm the selection has been saved.
6. Press **MUTE/PROG** to exit, or continue programming other settings.

## SETTINGS



## Setting the Time and Date

1. Press and hold the **MUTE/PROG** key.
2. Press **"3"** to access the **TIME SET** option.



3. Press the **FLASH/EDIT** button to change the selection. The month will start to flash.
4. Use the key pad to enter the month using 2 digits. For example January would be "01". The date will start to flash.
5. Use the key pad to enter the date using 2 digits. For example the first would be "01". The hour will start to flash.
6. Use the key pad to enter the hour using 2 digits. The minutes will start to flash.
7. Use the key pad to enter the minutes using 2 digits. AM and PM will start to flash.
8. Use the **"1"** button on the key pad to select **AM** and the **"2"** button on the key pad to select **PM**.
9. The time and date are now set. A double beep will be heard to confirm the selection has been saved. Press **MUTE/PROG** to exit, or continue programming other settings.

## Adjusting the Contrast of the Display

1. Press and hold the **MUTE/PROG** key.
2. Press **"4"** to access the **Contrast** option.



3. Press **FLASH/EDIT** button to change the setting. "2" will flash in the display.
4. Using the scroll keys **▼▲**, choose between the 3 levels of contrast.
5. Once you have selected the setting, press the **MEM/SAVE** button to save the selection. A double beep will be heard to confirm the selection has been saved.
6. Press **MUTE/PROG** to exit, or continue programming other settings. Setting the PBX Number

## SETTINGS

1. Press and hold the **MUTE/PROG** key.
2. Press "5" to access the PBX Number option.



3. Press **FLASH/EDIT** button to change the setting.
4. Using the scroll keys **▼▲** select the appropriate digit to match your PBX system.
5. Once you have selected the setting, press the **MEM/SAVE** button to save the selection. A double beep will be heard to confirm the selection has been saved.
6. Press **MUTE/PROG** to exit, or continue programming other settings.

## Turning the PBX Mode On or Off

1. Press and hold the **MUTE/PROG** key.
2. Press "6" to access the PBX Mode programming option.



3. Press **FLASH/EDIT** button to change the setting. "Off" will flash in the display.
4. Using the scroll keys **▼▲** select either **On** or **Off**.
5. Once you have selected the setting, press the **MEM/SAVE** button to save the selection. A double beep will be heard to confirm the selection has been saved.
6. Press **MUTE/PROG** to exit, or continue programming other settings.

## Changing the Pause Time

1. Press and hold the **MUTE/PROG** key.
2. Press "7" to access the Pause Time programming option.



## SETTINGS



3. Press **FLASH/EDIT** button to change the setting. "2" will flash in the display.
4. Using the scroll keys **▼▲** select the appropriate dialing delay.
5. Once you have selected the setting, press the **MEM/SAVE** button to save the selection. A double beep will be heard to confirm the selection has been saved.
6. Press **MUTE/PROG** to exit, or continue programming other settings.

## Deleting the Message Waiting Indicator\*

Clears the current Message Waiting indication.

1. Press and hold the **MUTE/PROG** key.
2. Press "8" to access the Message Waiting programming option.



3. Press **FLASH/EDIT** button to reset the message waiting indicator. "Delete" will flash in the display.
4. Press the **MEM/SAVE** button to delete the indication. A double beep will be heard to confirm the deletion.
5. Press **MUTE/PROG** to exit, or continue programming other settings.

\* Message Waiting Indication operates with your local telephone company's Voice Mail service which requires a subscription.

## Turning Auto-Answer On or Off

**Auto-Answer** allows you to answer the phone as soon as you lift the handset from the base without pressing the "TALK" button. The factory default setting is "Off".

1. Press and hold the **MUTE/PROG** key.
2. Press **◀✳** to access the **Auto-Answer** programming option.



3. Press **FLASH/EDIT** button to change the setting.
4. Using the scroll keys **▼▲** select between **On** and **Off**.

## SETTINGS

- Once you have selected the setting, press the **MEM/SAVE** button to save the selection. A double beep will be heard to confirm the selection has been saved.
- Press **MUTE/PROG** to exit, or continue programming other settings.

## Disabling the Ring for Private Calls

- Press and hold the **MUTE/PROG** key.
- Press "0" to access the **Private Ring** programming option.



- Press **FLASH/EDIT** button to change the setting.
- Using the scroll keys **▼▲** select between **On** and **Off**.
- Once you have selected the setting, press the **MEM/SAVE** button to save the selection. A double beep will be heard to confirm the selection has been saved.
- Press **MUTE/PROG** to exit, or continue programming other settings.

**Note:** The phone will still ring once when set to "Off" unless the **First Ring** function is also set to "Off".

## Disabling the Ring for Unavailable Calls

- Press and hold the **MUTE/PROG** key.
- Press the "9" button to access the **Unavailable Ring** programming option.



- Press **FLASH/EDIT** button to change the setting.
- Using the scroll keys **▼▲** select between **On** and **Off**.
- Once you have selected the setting, press the **MEM/SAVE** button to save the selection. A double beep will be heard to confirm the selection has been saved.
- Press **MUTE/PROG** to exit, or continue programming other settings.

**Note:** The phone will still ring once when set to "Off" unless the **First Ring** function is also set to "Off".

## SPEED DIALING



The Unit will store up to 20 speed dial numbers. The speed dial numbers will appear in the order in which they were entered. Please note the same number cannot be entered more than once.

## Storing Phone Numbers

- With the handset in the idle state, press **MEM/SAVE**.



- Press the **FLASH/EDIT** button to enter a name and number in the Phone Book.
- To enter a name use the key pad. You can use up to 15 letters. Please refer to the table below on how to select the letters. To create a space between words, press "1".

## For example, to enter the name PhoneMate do the following:

- Press 7 once for the letter "P"
- Press 4 twice for the letter "H"
- Press 6 three times for the letter "O"
- Press 6 twice for the letter "N"
- Press 3 twice for the letter "E"
- Press 6 once for the letter "M"
- Press 2 once for the letter "A"
- Press 8 once for the letter "T"
- Press 3 twice for the letter "E"



- Press scroll key **▼** and enter the phone number. You can use up to 16 digits. Press **Redial** to insert a dialing pause into the number. The pause uses one digit of the 16 digits available. Please refer to the table (see pg. 24) on how to select the numbers.





- Press **MEM/SAVE** to save the entry to your phone book.

## SPEED DIALING

KEY #	Press once	Press twice	Press 3 times	Press 4 times	Press 5 times	Press 6 times	Press 7 times	Press 8 times
1	space	&	,	(	)	*	.	1
2	A	B	C	2	A	B	C	2
3	D	E	F	3	D	E	F	3
4	G	H	I	4	G	H	I	4
5	J	K	L	5	J	K	L	5
6	M	N	O	6	M	N	O	6
7	P	Q	R	7	P	Q	R	7
8	T	U	V	8	T	U	V	8
9	W	X	Y	Z	9	W	X	Y
0	0	0	0	0	0	0	0	0

**Note:** If the memory is full and there are no locations left in the phone book, the display will read "MEMORY FULL". You will then have to delete an existing name and number to make another entry.

**Note:** To edit or correct a mistake, use the  button and  button to select the letter or number you wish to change. The letter or number selected will flash. Press the **REDIAL/DELETE** button to delete the letter or number you wish to change.



## Viewing the Phone Book

1. Press **MEM/SAVE** to enter the phone book.



2. Press   to find the desired entry.



3. If the name and/or number is greater than 11 characters, press the  or  to see the rest of the entry. There are arrows that will appear in the top line of the display.





4. Press **MEM/SAVE** to exit the phone book. If you do not exit, the phone book will exit automatically after a short while.

## SPEED DIALING

## Making a Call from the Phone Book

1. To place a call using the phone book, press **MEM/SAVE**



2. Use the   to scroll through the phone book until you find the desired entry.





3. Press **TALK**. The display will show the name and number and will begin dialing the number.
4. When you have finished your call, you can press **TALK** to end the call or place the handset back in the base.

## Deleting a Name and Number from the Phone Book

1. Press **MEM/SAVE**.



2. Use the   to scroll through the phone book until you find the desired entry.



3. Press **REDIAL/DELETE**



4. Press **REDIAL/DELETE** again to delete the selected entry. The display will show "ERASED" for a moment and will then return to the previous entry in the phone book.
5. Press **MEM/SAVE** when you are finished.

## SPEED DIALING

## Editing a Stored Name and Number

1. Press MEM/SAVE.



2. Use the ▼▲ to scroll through the phone book until you find the desired entry.



3. Press FLASH/EDIT. Using the ▼▲, [←\*] and [#→] keys, move the cursor to the letter or number you wish to change.

**Note:** When moving the cursor through the number field, you will have to press and hold the [←\*] and [#→] until you see the cursor move. Pressing and releasing the [←\*] and [#→] keys will enter these symbols into the dialing sequence. Pressing any dial pad key will insert that key before the cursor.

4. To delete a number or letter, press the REDIAL/DELETE button.

**Note:** To delete a number, it is necessary to press and hold the REDIAL/DELETE button until the number is deleted, as pressing and releasing it will insert a pause into the dialing sequence.

5. Press MEM/SAVE when you are finished.

## Priority (VIP) Calls \*

You can identify numbers stored in your phone book as VIP calls. When that number calls you, the Caller ID information is matched to the same name and number in your phone book that has been identified as a VIP Caller. The phone will then generate a special ring sound after the first ring, once the caller ID information has been received.

## SPEED DIALING

## To identify an entry in your phone book as a Priority VIP call:

1. Press MEM/SAVE.
2. Use the ▼▲ to scroll through the phone book until you find the desired entry.



3. Press the MUTE/PROG button once. The display will now show the "VIP" icon.



4. Press MEM/SAVE when you are finished.

## Blocked (REJ) Calls \*

If you do not want the phone to ring when a particular number calls, you can identify that number in your phone book and block it from ringing. When that number calls you, the Caller ID information is matched to the same name and number in your phone book that has been identified as a Blocked or Rejected call. The phone will then not ring after the first ring, once the caller ID information has been received.

## To identify an entry in your phone book as a Blocked or Rejected call:

1. Press MEM/SAVE.
2. Use the ▼▲ to scroll through the phone book until you find the desired entry.



3. Press the MUTE/PROG button twice. The display will now show the "REJ" icon.



4. Press MEM/SAVE when you are finished.

\* **Note:** Priority VIP and Blocked/Rejected calls will only function provided the incoming call's number is exactly the same as the number in your phone book. This feature requires a subscription to Caller ID offered by your local telephone company.

## CALLER ID

Caller ID displays the caller's name and number on the LCD, which allows you to see who is calling before you answer the call. This feature requires a subscription to the Caller ID service offered by your local telephone company.

### When a Call is Received

1. When the phone rings, the caller's name and number will appear on the display.



2. The new Caller ID memory includes the name and number of the caller, along with the time and date that they called. The New Call indicator will flash indicating that there is a new Caller ID stored in the memory.

**Note:** Once the Caller ID information is received it is stored in the Caller ID memory. This information can be recalled later to return the call. The PM2420 can store up to 40 calls.

### Viewing the Caller ID Memory

The PM2420 will automatically store the last 40 calls received. If the same number calls more than once, since the last New Call Indicator was reviewed, it will not be recorded again, but will have the Repeat Call icon "RPT" appear along with the number of times they have called.

#### To review the Caller ID memory:

1. Press the **CID** button to access the Caller ID log.
2. The new or unviewed calls will appear first, with the most recent call being displayed first. It will also include the Name of the person the number is registered to, along with their number, the time that they called as well as the date.



3. If the entry is greater than 11 characters, use the **◀ \* ▶** and/or the **# ▶** buttons to view the rest of the display.
4. To view the rest of the caller ID log, press the **▼** or **▲** to scroll through the memory.
5. Press **CID** to exit.

## CALLER ID



### Different Types of Caller ID Displays



Illustrates the name, number, time and date of the call.



Illustrates number only service.

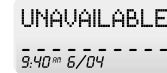

**UNAVAILABLE** is displayed when the caller ID information is not available. This can be a call through a telephone company that does not offer the service or an international call.

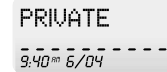

**PRIVATE** indicates that the call was made from a blocked number. For reasons of privacy, some areas allow the caller to hide or prevent their caller ID from being displayed.



**ERROR** indicates that there was a problem with the transmission of the caller ID information. When there is an error in receiving the caller ID information the call is not included in the Caller ID memory.



**MSG WAITING** indicates that there is a voice mail message waiting to be retrieved. This requires a subscription to the voice mail service offered by your local telephone company.



Illustrates that the incoming call is a Priority Call.



**NO CALLS** illustrates that there are no calls stored in the Caller ID memory.

### Call Waiting Caller ID Service

The Call Waiting Caller ID feature requires a subscription to the Call Waiting Caller ID service offered by your local telephone company. Your local telephone company will need to offer a Call Waiting service as well as a Caller ID service.

If someone tries to call you while you are currently having a telephone conversation, your PM2420 will generate a "beep" and will temporarily mute the handset volume, to notify you that someone else is attempting to call you. The Caller ID information of the person who is attempting to call you will appear on the display, providing it is available.

1. When a "Call Waiting" notification is received and after reviewing the caller ID information you decide you wish to answer this second call, press the **FLASH** button once. The first call will be placed on "Hold" and the second call will be activated.
2. To switch back and forth between both calls, continue to press the **FLASH** button each time.

## CALLER ID

- To end one call, press the **FLASH** button at the end of the conversation. As the caller also hangs up, that call will be terminated and the other call will now be active.
- To end that last call, press the **TALK** button to end the call or place the handset back in the base.

## Deleting Caller ID Records

When reviewing the Caller ID memory, you can delete any or all of the Caller ID records.

## To Delete a Single Caller ID Record

- Press the **CID** button to access the Caller ID Memory
- Use the **▼▲** to scroll through the Caller ID memory until you find the desired entry.
- Press the **REDIAL/DELETE** button



- Press the **REDIAL/DELETE** button a second time to delete the selected Caller ID entry.

- Press **CID** to exit the Caller ID Memory.

## To Delete All Caller ID Records

- Press the **▼** or **▲** button or press the **CID** button to access the Caller ID memory.
- Press and hold the **REDIAL/DELETE** button. The display will show "ERASE ALL?"



- Press the **REDIAL/DELETE** button a second time to delete all the Caller ID records. The display will show "ERASE ALL?".

## Returning Calls from the Caller ID Memory

You can return calls by using the Caller ID Memory to dial the phone number. Due to current telephone company dialing conditions, some areas of the country require the area code to be included when even a local call is placed. This requires a 10 digit number to be dialed. If the call is a long distance call 11 digits are required as a "1" is required before dialing the area code and then the number.

## CALLER ID

- Press the **CID** button to access the Caller ID Memory
- Use the **▼▲** to scroll through the Caller ID memory until you find the desired entry.



- If the number in the Caller ID memory is not complete, use the **CALL BACK** button to switch between the 2 redial options that are available.

A. 10 digits which include the area code plus the phone number

B. 11 digits which include a "1" before the area code, the area code and the phone number.



- Press the **TALK** button to dial the number in the display.
- Press the **TALK** button again to end the call when you are finished, or place the handset back in the base.

## Message Waiting Notification

If you subscribe to a Voice Mail answering service that maybe offered by your local telephone company and if you have Voice Mail messages that you have not heard, "MSG WAITING" will be shown in the LCD.



**Note:** This feature requires your local telephone company to offer a voice mail notification service called **FSK** (Frequency Shift Key). Please note that not all telephone companies offer this service. Please consult your local telephone company to find out if this service is available in your area.

**Tip:** If you want to delete the "Message Waiting" notification, please refer to "MSG Waiting Delete" in the Settings section.

## New Call Indicator

When there is a new Caller ID notification, Voice Mail notification or when a call is received, the New Call light will flash.



## OTHER FEATURES

### Using the Handset Finder (PAGE)

1. Press **Page** on the base. If the handset is within range, a triple beep will sound for 50 seconds.
2. Place the handset back into the base or press the **TALK** key on the handset to stop the page/find feature.

### Security Code

The security code prevents your cordless telephone conversation from being accessed by a phone on a different line. Once the handset battery is fully charged, the handset will automatically select the code from a total of over 65,000 combinations. The code is changed every time the handset is placed in the cradle (indicated by a beep).

If you experience difficulty with placing or receiving calls, a lost security code may be the cause of the problem. When this occurs, the handset can no longer communicate with the base. Reset by placing the handset on the base for 5-10 seconds. If that does not work, unplug the AC adapter from the wall outlet. Disconnect the handset battery for 5-10 seconds and then reconnect. Place the handset back on the base and then replug the AC adapter.

### Channel Changing

If you are experiencing interference during a telephone call, press the **CH** key. The Unit will scan up to 40 channels and select the clearest one to provide the best possible reception.

### Out of Range Warning

If the handset is moving too far away from the base, the handset will beep and the display will show "**OUT RANGE**". Move closer to the base to maintain the connection on your phone call. Otherwise, the call maybe disconnected. If you try to access the line while the handset is out of the range of the base, the display will show "**TRY AGAIN**".

## CARE AND MAINTENANCE



Your PhoneMate PM2420 telephone has been designed to give years of trouble-free service. It is a sensitive electronic instrument. To assure its longevity, please read the following maintenance instructions.

1. Keep the PM2420 away from heat as high temperatures can shorten the life of the electrical components and distort or melt its plastic parts.
2. The PM2420 should be kept free of dust and moisture. If it gets wet, wipe it dry immediately. Liquids can contain minerals that can corrode electronic circuits.
3. Handle your PM2420 gently and carefully. Dropping it can cause serious damage to circuitry, or the plastic case, which may result in malfunction.
4. Do not use any type of chemical or any abrasive powder to clean the cabinet. Use only mild detergents on a soft damp cloth to clean the PM2420 telephone.
5. The PM2420 has built-in surge protection circuits that meet or exceed FCC requirements. However, an incident such as a lightning strike at or near the telephone lines, could cause serious damage.
6. If the PM2420 is installed in an area with frequent or severe electrical storms, it is suggested that the telephone be disconnected during these storms or that additional surge suppression equipment be added to the installation.
7. In the case of trouble with the telephone, do not attempt to repair the telephone yourself. It is the responsibility of users requiring service to report the need for service to our Service Department. They will make the necessary arrangements for repair or replacement.
8. If you should have any questions regarding the operation of your PhoneMate PM2420, please visit our web site: [www.phonemate.com](http://www.phonemate.com)
9. Please register your product by mailing in the Product Registration form included with your PhoneMate PM2420

## TROUBLE SHOOTING

No dial tone/phone will not dial out

- Check that the AC power adapter is plugged into a working AC power outlet.
- Check all telephone cord connections or try another wall jack
- Do a basic reset of the phone: Disconnect the phone from the wall and remove the battery for 30 minutes and then re-install as instructed by the manual.
- Try other phones in the house to ensure it is not a line problem with the telephone company.
- Was the battery charged for at least 12 – 15 hours?
- Does the display show "LOW BATTERY"?

Can't hear the ring signal

- Check the ringer volume controls; verify that the switch is not set to "Off"
- Check that the AC power adapter is plugged into a working AC power outlet.
- Check all telephone cord connections or try another wall jack

While on a call, you hear another call on the line or experience radio frequency interference

- Switch channels to a clear channel
- Check the wiring for bad connections
- Do not use this phone within close proximity to other electronic appliances such as TV's, VCR's and microwave ovens

Can't receive or make phone calls

- Check if the phone is set to the correct type of service, either Tone or Pulse
- Check that the AC power adapter is plugged into a working AC power outlet.
- Check all telephone cord connections or try another wall jack
- Check to make sure that the Battery is properly installed and connected

There are continuous short beeps instead of a dial tone when the handset is far from the base

- The beeps are a warning that you are too far away from the base. Move closer to the base.

## TROUBLE SHOOTING

Model PM2420

There is interference on the handset

- Was the battery charged for at least 12 – 15 hours?
- Does the display show "LOW BATTERY".
- Move closer to the base.
- Is the phone within close proximity to other electronic appliances such as TV's, VCR's and microwave ovens?

The display shows "LOW BATTERY" after a few telephone calls, even though the battery has been fully charged for 12-15 hours

- Replace the battery pack with a new battery

The Charge Light will not come on when the handset is place in the base unit

- Check to ensure sure that the AC Adapter is plugged into the base unit and an operating wall outlet.
- Ensure sure that the handset is properly seated in the base unit
- Ensure that the rechargeable battery pack is properly connected in the handset.

The Caller's voice is too low or quiet

- Adjust the receiver Volume Control on the handset to a higher setting

The Handset does not display the Caller ID information

- Check with your local telephone company to ensure that the Caller ID or Call Waiting Caller ID service is subscribed to and is functioning properly.
- If you answer the call before the first ring has been completed, the Caller ID information may have not been completely received by your PM2420.

The LCD display is blank or hard to read.

- Adjust the contrast for the display

Telephone Numbers are not being correctly dialed from the Caller ID memory

- Ensure that the number displayed is in the correct format and that if the area code and/or a "1" are included in the dialing process.

EXTRA HELP

- Should you have any additional questions, please visit our web site at [www.phonemate.com](http://www.phonemate.com)

## GLOSSARY

**PBX (Private Branch Exchange)** – A small, central, privately owned, switching telephone system where a digit (like "9") must be dialed first in order to access an outside line

**FLASH** – A signal sent by the phone to the local telephone company supporting services such as call waiting.

**REDIAL** – Performs single button dialing of the last number dialed

**RINGER LEVEL CONTROL** – Permits adjustment of the ringer volume level.

**SPEED DIALING** – Allows programming of frequently dialed numbers so that they can be dialed with the two touch speed dial button

**TONE/PULSE OPTION** – Enables you to switch from pulse (rotary dial method) to tone (push button) dialing.

**VOLUME LEVEL CONTROL** – Permits volume adjustment of the handset and headset during a conversation.

**LCD** – Liquid Crystal Display – This is the display on the handset used to display the Caller ID information as well as in programming the PM2420

**FSK** – Frequency Shift Key – A type of signalling service used for Voice Mail and other services offered by some local telephone companies.

**Voice Mail** – A service offered by some local telephone companies where callers can leave a voice message when no one answers the phone call.

**Caller ID** – The information received by your PM2420 from the telephone company about the person who is calling you. Depending on your local telephone company this can be the phone number of the person who called you and/or the name of the individual that the phone number is registered to.

**Call Waiting** – A service offered by some local telephone companies, whereby an audible notification is sent to you while you are currently on the phone, indicating that someone else is attempting to call you.

**Call Waiting Caller ID** – A service offered by some local telephone companies, whereby an audible notification along with the number and name (if available) is sent to you while you are currently on the phone, indicating that someone else is attempting to call you providing you with the information on who that individual is

**Contrast** – The brightness of the display

## WARRANTY

Model PM2420

### IMPORTANT! SALES SLIP OR EVIDENCE OF PURCHASE DATE REQUIRED.

This limited warranty gives you specific legal rights: you may also have other rights, which vary from state to state. The limited warranty is extended only to the original consumer of a PhoneMate branded product by the Manufacturer and is valid only with respect to consumers within the United States of America and Canada. Should this product prove defective by reason of improper workmanship or material during the period of one (1) year from date of original purchase, the Manufacturer will repair or, at its option, replace the product without charge for parts or labor. If Manufacturer elects to replace the product, such replacement may be accomplished with a factory-reconditioned unit.

This limited warranty does not apply: (a) to any product damaged by accident, misuse, improper line voltage, lightning, fire, water, or other acts of nature, (b) if the product is altered or repaired by anyone other than the Manufacturer or one of its authorized warranty stations or (c) if the FCC-approved connector plugs are removed. This limited warranty does not cover broken or marred cabinets.

Except to the extent prohibited by law, all implied warranties made by the Manufacturer in connection with this product are limited in duration to a period of one (1) year from the date of original purchase, and no warranties, whether expressed or implied, shall apply to this product after said period.

Should this product prove defective in workmanship or material, the consumer's sole remedies shall be such repair or replacement as is herein above provided. Under no circumstances shall the Manufacturer or PhoneMate Corporation be liable for any loss or damage, direct, consequential, or incidental arising out of the use of or inability to use this product.

Some states do not allow limitations on how long an implied warranty lasts or the exclusion or limitation of incidental or consequential damages, so the above limitations or exclusions may not apply to you.

In order to obtain warranty service, you must provide evidence of purchase date. For your convenience, keep the dealer's dated bill of sales or delivery ticket as evidence of the purchase date.

PhoneMate and the PhoneMate Logo are registered trademarks of PhoneMate Corporation and are used under license from PhoneMate Corporation.

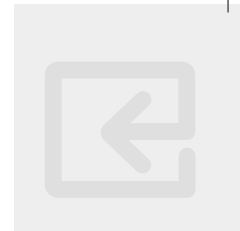

Model PM2420

2.4GHz

CORDLESS  
TELEPHONE  
WITH CALL  
WAITING  
CALLER ID

[www.phonemate.com](http://www.phonemate.com)

INSTALLATION  
AND  
OPERATING  
GUIDE