

VENDYS II

Operation Manual- VENDYS Portable

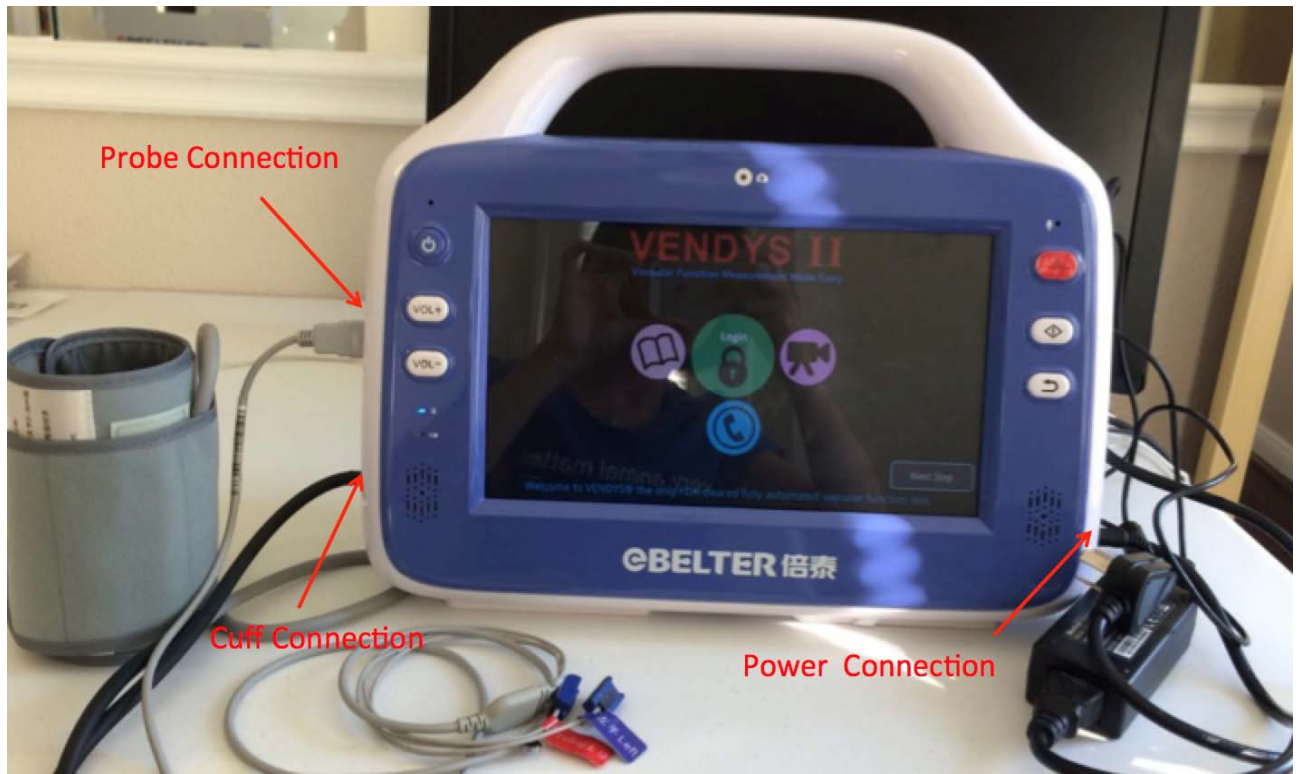

Table of Contents

VENDYS® Support	4
Technical Information	5
Operating the Device	5
Cleaning	6
Cleaning the Cuffs	6
Indication of Use	6
Preparation and Optimal Conditions for VENDYS Test	7
Factors affecting vascular reactivity:.....	7
Subjects preparation:	7
Environmental Conditions:	7
VENDYS Assembly Instruction	7
Introduction to theJK001V device	7
Preparation.....	12
Assembly:.....	14
Probes connection	14
Cuff Connection.....	14
Power Connection.....	14
System Check	14
Cold Finger Kit	15
Non-Invasive Infrared Temperature Gun	15
Electric Heating Blanket.....	15
How is This Kit Used?	15
VENDYS II Test Procedures	16
Set up an Operator	16
Turn on VENDYS Machine	16
Admin Login	19
Set up the Name of the Clinic	22
Start a VENDY Test (Login as Operator)	23
Test Preparation---Optimal Conditions	23
Finger Size Selection	26
Cuff Placement.....	27
SubjectTemperature Sensor Setup	28
Fingertip Temperature Sensor Attachment.....	29
Lap Pad Setup	30
Patient Demographic and Health Information.....	31
Blood Pressure Measurement.....	33
VENDYS Vascular Function Test.....	35
VENDYS II Graphic User Interface	51
Login Page	51
Login	51
Video Gallery	53
Tutorial.....	54
Contact Us.....	56
VENDYS II Main Page	57
Add Operators	57
Settings	61
Tutorial.....	68
Contact Us.....	68

Video Gallery	68
Patient Records:.....	68
Troubleshooting.....	75
Cannot get info from Probes	75
Low Battery	75
Battery problem.....	75
Failed to get information from SD card	75
Cannot turn on the machine	75
The monitor cannot display very well after turning on the machine	75
The screen is stuck on the booting video page.....	75
Keypad is not coming out while typing.....	75
VENDYS keeps rebooting after turning on.....	75
Touch screen is not working.....	76
Blood pressure cuff cannot be inflated	76
Cuff leakage problem.....	76
Inappropriate placement of BP Cuff (other cuff problems)	76
Technical Information:	77
Temperature Probes (RTD) Specification	77
VENDYS II Machine Specification	77
Product Labels	78
Packing List for VENDYS System.....	79
Appendix A: License Agreement and Limited Warranty.....	80

VENDYS® Support

If you have any questions regarding the setup and/or operation of the VENDYS® device, please contact:

Endothelix Customer Support

713-529-2599

<http://support.endothelix.com>

support@endothelix.com

Technical Information

This manual describes the function of the VENDYS-II JK-001V vascular function testing device (hereafter referred to as VENDYS-II): performance, operation method and other safety information content.

Operating the Device

- VENDYS-II can be powered by a built-in battery or an AC power supply. The device is easy to carry with a built-in handle.
- The device is not a therapeutic device, it is intended for measurement purposes only.
- This equipment is suitable for adults and children over the age of 12 and not for use on younger children and infants.
- To prevent personal injury or equipment damage, make sure the device is properly placed on a sturdy surface. Improper placement may result in equipment damage and/or personal injury.
- Do not place or operate the VENDYS-II device in the vicinity of magnetic resonance imaging (MRI) equipment, as the induced currents can result in severe injuries or burns to the testing personnel.
- Do not place or operate the device in the presence of flammable substances, flammable anesthetic gases or other open-gas appliances.
- Do not place or operate the device in the presence of strong electromagnetic radiation devices.
- To prevent injury, device operation and maintenance is strictly reserved for qualified technical personnel.
- The device may only be used with the original supplied power adapter and power cord. Do not attempt to operate the device using other power cords or adapters.
- Pay attention to the placement of the power cords, catheters and all other cables. Keep liquids and other potentially dangerous objects away from the device in order to prevent personal injury. In the case of liquid spilling and contacting the device, disconnect the power immediately and contact service personnel.
- To prevent the device from overheating, keep away from all objects that may obstruct the back ventilation area of the device.
- Do not open the instrument shell in order to avoid the possible risk of electric shock. All instrument maintenance and upgrades are reserved for trained and authorized service personnel.
- Prior to device operation, thoroughly inspect the equipment and its accessories.

- The device test results are for reference only. The results cannot be used as a diagnosis.
- Be sure to properly connect all cables to the device.
- Keep device packaging away from children and properly dispose of unwanted packaging in accordance with current waste control regulations.

Cleaning

Blood pressure cuffs are listed as low-risk and non-critical items for disinfection. That being said, recent research has found them to be key in the spread of MRSA (an antibiotic-resistant bacteria) in hospitals. The proper cleaning of these cuffs ensures that dangerous bacteria does not spread between patients. Endothelix does not assume responsibility for the effectiveness of these chemicals as a means of control of infectious diseases. Follow Guideline for Disinfection and Sterilization in Healthcare Facilities published by United States Center for Disease Control.

Cleaning the Cuffs

1. Prepare a mild detergent and distilled water solution and a 10% bleach solution in separate spray bottles.
2. Spray detergent solution on cuff, tubing and hose.
3. Wipe smooth surfaces with a soft cloth. Use a soft bristle brush on visibly soiled areas and irregular surfaces;
Note: Do not allow fluid to enter the cuff tubing or cuff.
4. Rinse with distilled water.
5. To disinfect, spray 10% bleach solution on cuff and allow to sit for 5 minutes
6. Wipe excess solution and rinse with distilled water.
7. Let dry thoroughly for 2 hours.

Indication of Use

VENDYS[®] is a non-invasive, digital, electronic thermometer and non-invasive blood pressure measurement device. This device is used to continuously and simultaneously measure surface temperature at multiple sites (e.g. fingertips on the test and control hands) and also measure blood pressure at the brachial artery.

It is intended to be used for measurement of vascular reactivity by monitoring temperature changes before, during, and after a reactive hyperemia test, using a 2-5 minute cuff occlusion procedure, and calculates multiple indices based on temperature changes.

The VENDYS® device is intended for use by competent healthcare professionals in a clinical or research setting. It is intended to supplement, not substitute for, the physician's decision making process, and it should be used in conjunction with the patient's history and other clinical findings.

Preparation and Optimal Conditions for VENDYS Test

Factors affecting vascular reactivity:

- Ambient temperature
- Time from food intake
- Drugs
- Sympathetic stimuli

Subjects preparation:

- Rest for at least 6 hours before the TEST
- Do not exercise for 6 hours before test
- Do not exercise during the test
- Be tested in a quiet, temperature-controlled room
- Withhold all vasoactive medications for at least four half-lives
- Do not ingest substances that might affect vascular reactivity such as caffeine, high-fat foods and vitamin C or use tobacco for at least 4 to 6 hours before the test

The operator should be cognizant of the phase of the subject's menstrual cycle which may affect the response. These confounding factors must be considered in preparing a subject for studies that seek to determine the impact of a single intervention. For observational cohort studies, data must be collected on those factors known to affect the measurement of response, and analysis should address their impact.

Environmental Conditions:

Ambient room temperature should be kept constant at/around 24°C. Bright lights, movement of other people, fans, direct sunlight, or being seated near an AC vent may cause mental stress and affect the test results, so they should be avoided. It may be helpful to dim the lights or have the patient wearing headphones. The environment should be calm and stable.

VENDYS Assembly Instruction

Introduction to the JK001V device

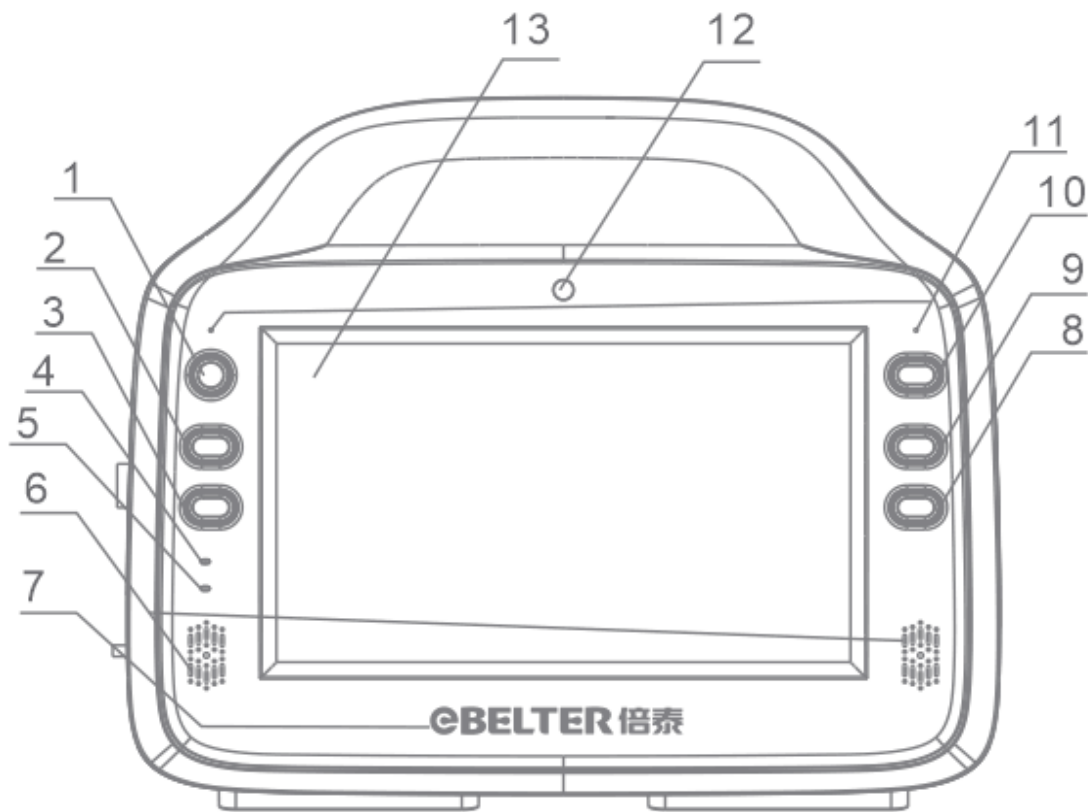

Figure 1-1 Front view

Number	Function
1	Power switch button
2	Volume increase button
3	Volume decrease button
4	Status indicator (Blue indicates the device is on. No light indicates the device is turned off).
5	Charging status Indicator (Blue indicates the device is charging; Green indicates charging is complete)
6	Speakers

7	Device label
8	Return button
9	Servicebutton (no effect in normal operation)
10	Emergency shut-off button
11	Microphone
12	Camera
13	LCDscreen

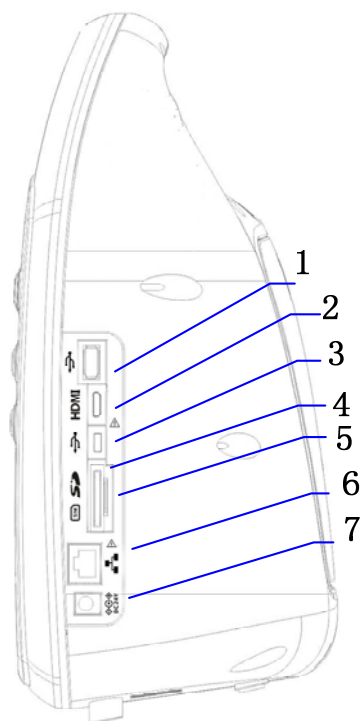

Figure 1-1 Right-side view

Number	Function
1	USB port
2	HDMI port
3	Micro-USBport
4	SD card slot
5	Null
6	Ethernet cable port
7	DC power input port

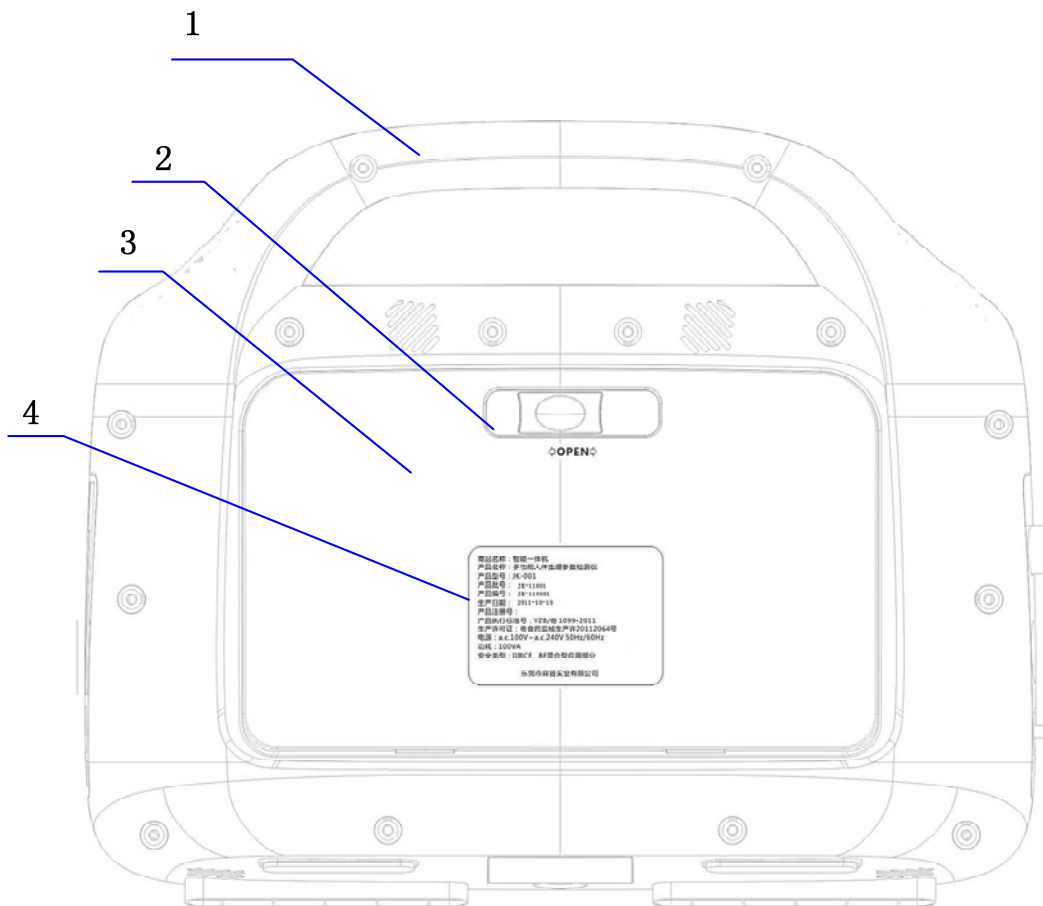

Figure 1-3 Rear-view

Number	Function
1	Handle
2	Built-in storage latch
3	Back coverplate
4	Nameplate

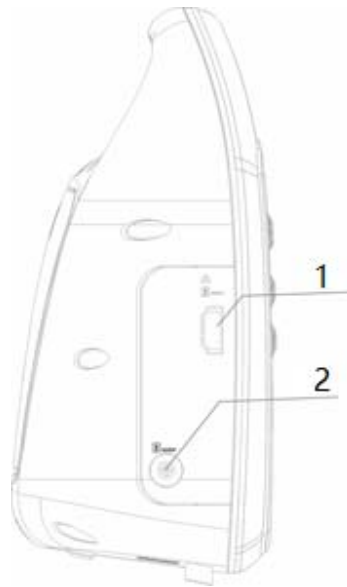

Figure 1-4 Left-side view

Number	Function
1	Probe HDMI connection
2	Cuff NIBP hose connection

Preparation

Carefully remove all components from the packaging to obtain the VENDYS II machine and corresponding VENDYS probes and cable. Please check necessary items according to the packing list (provided in the package) and make sure all the items included in this package are received. At the same time, please check if any mechanical damages happened to the VENDYS machine. If any, please contact Endothelix support to receive a replacement.

JK-001V 无创心血管装箱示意图

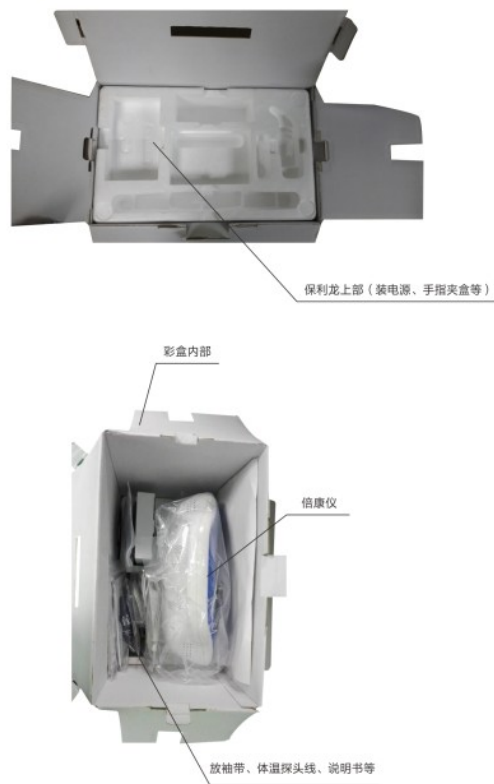

All words should be written in English

Assembly:

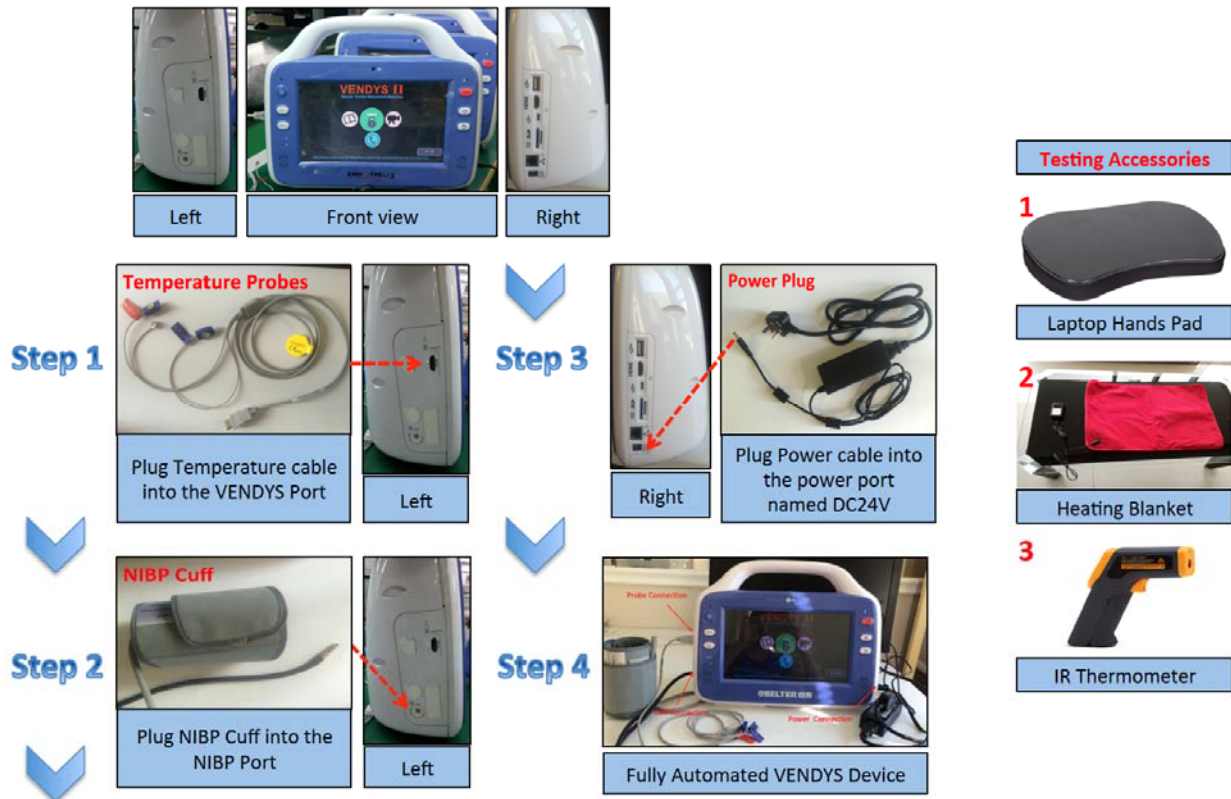

Probes connection

Connect the Probes to the HDMI port on the left side of the VENDYS II machine.

Cuff Connection

Connect the cuff to the NIBP port on the left side of the VENDYS II machine. Simply insert the air tube into the port until you feel a click.

Power Connection

Connect the power and adaptor cable to the port marked 'DC 24V' on the right side of VENDYS II machine. Plug the power cable into a wall outlet.

System Check

After plugging the power cable into a wall outlet, the bottom left light on the front of the device should turn blue.

If the blue light does not appear, make sure all components are properly connected. If you still require assistance refer to the Support section at the end of the QuickStart guide.

Cold Finger Kit

Non-Invasive Infrared Temperature Gun

Non-invasive infrared temperature gun can be used to detect the fingertip temperature quickly before the VENDYS test. Once the cold finger is detected (The temperature of fingertip is below 27 Centigrade), heating blanket should be applied to warm up the patient. Cold finger might cause the vessel constriction during the VENDYS test, thus affecting the test results.



Electric Heating Blanket

Electric heating blanket is applied to the patient shoulder and neck to warm up the patient when they suffer from cold finger (The fingertip temperature of the patient is below 27 Centigrade) and prepare the patient with the following VENDYS test. Please apply the electric heating blanket to the patient as the following instruction.



How is This Kit Used?

Cold Finger Kit is used before the VENDYS test. First, measure the fingertip temperature of patient before the VENDYS test.

1. If the patient fingertip temperature is above 27 centigrade, which suggests he/she is ready for the VENDYS test.
2. If the patient fingertip temperature is below 27 centigrade, the heating blanket should be applied to warm up the patient for few minutes. Once the patient's fingertip temperature is above 27 Centigrade, they are ready for the VENDYS test.

VENDYS II Test Procedures

Set up an Operator

Turn on VENDYS Machine

1. Press and hold the “” button on the right side of the device for a few seconds until the following page shows up.



2. This page will last for 3 seconds. Then the following page will show up, this page will also last for 3 seconds.



3. A short video will show up after the second introduction page, this short video will last 60 seconds, which will give you a brief introduction to the VENDYS test.

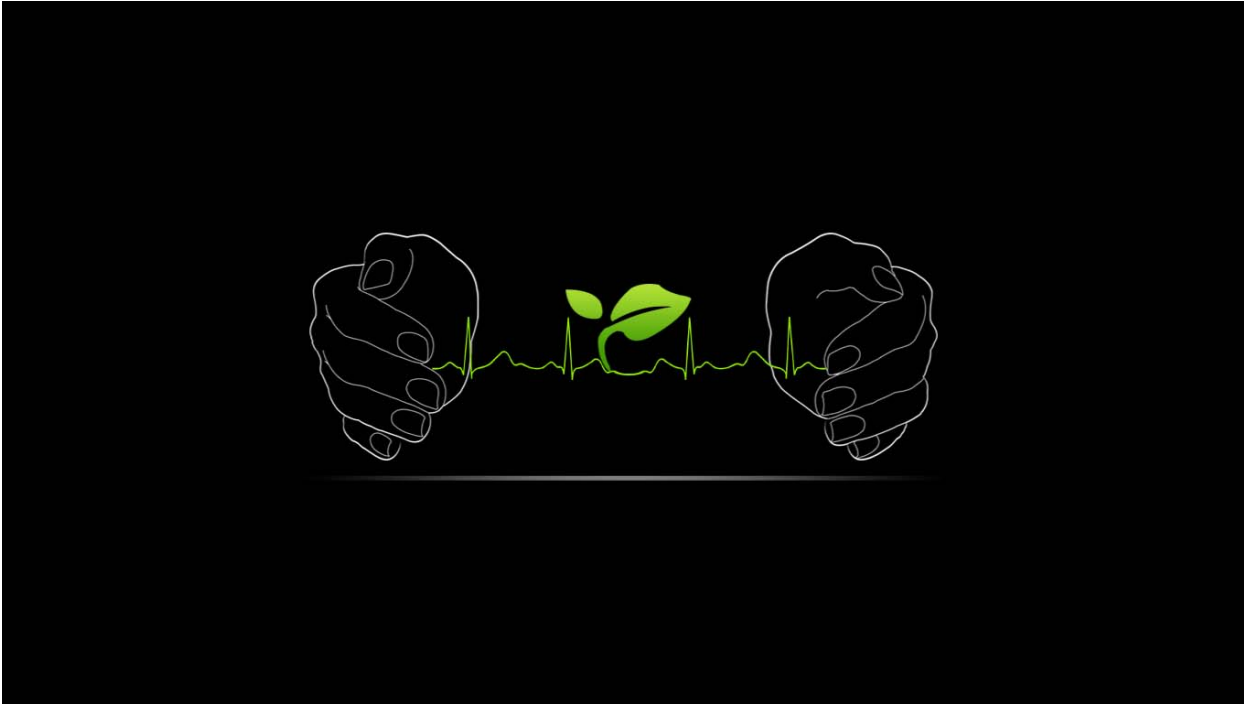

4. After that, the login page will show up as follows:

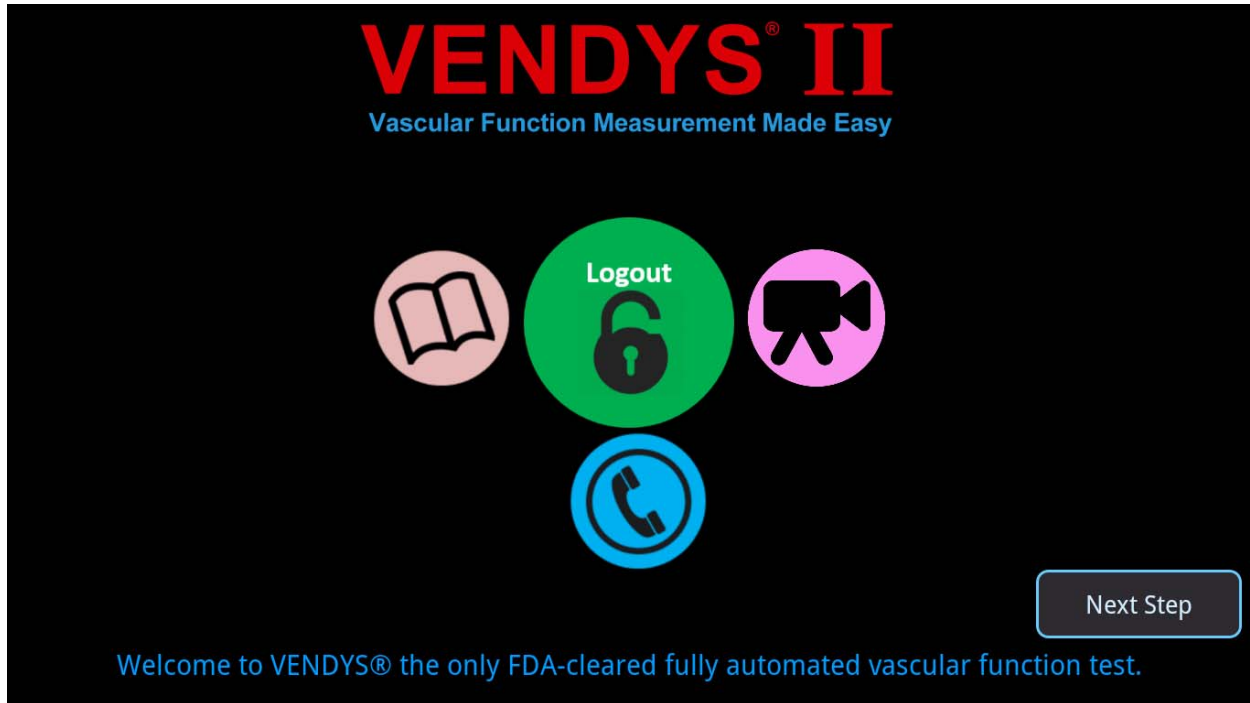

Admin Login

1. After touching the green “Login” button in the middle of the login page, it will lead you to the following login page.

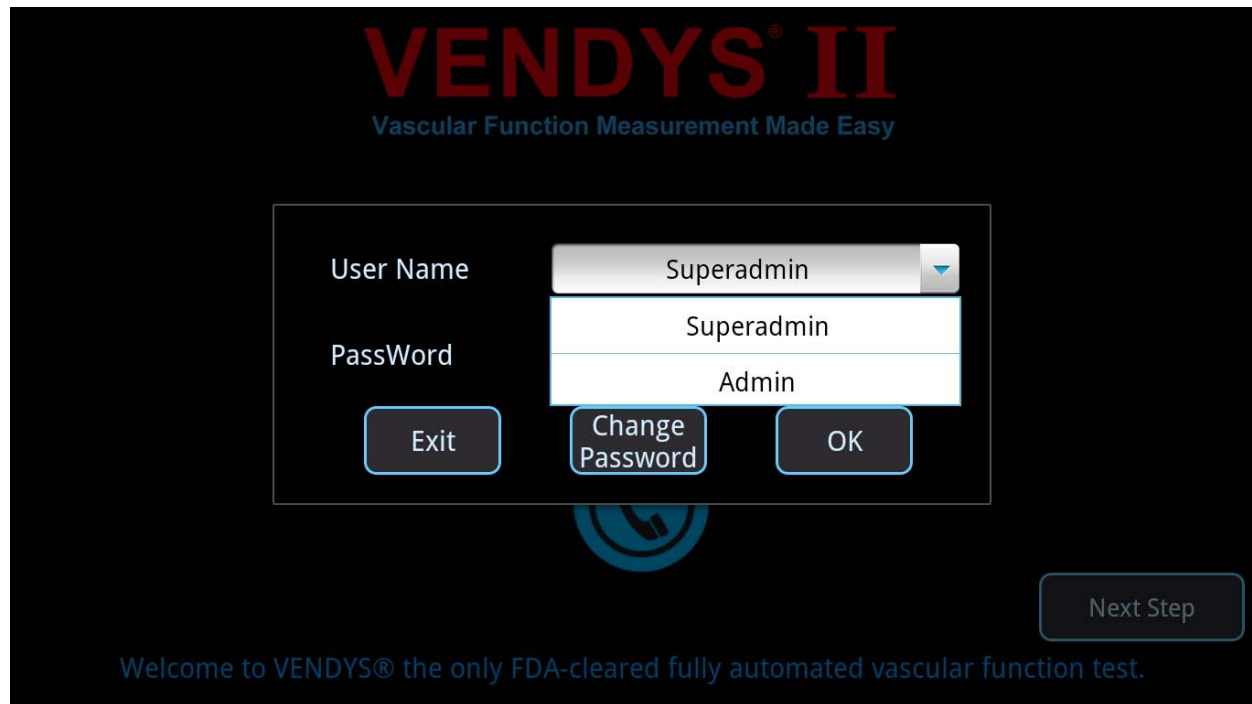

There are three options for the customer to choose:

1. **Superadmin**: this is for the Endothelix technical support.
 2. **Admin**: this is for the administrator of local clinic. Additional operators can be added via this account
 3. **Operator(s)** (This option will show up after adding operators on the following main page)
2. Please choose the “admin” as the “User Name”. The default password for “Admin” is “888888”.

User Name	admin
Password	888888

After that, click on “OK” to enter the VENDYS II system and the following main page will show up:

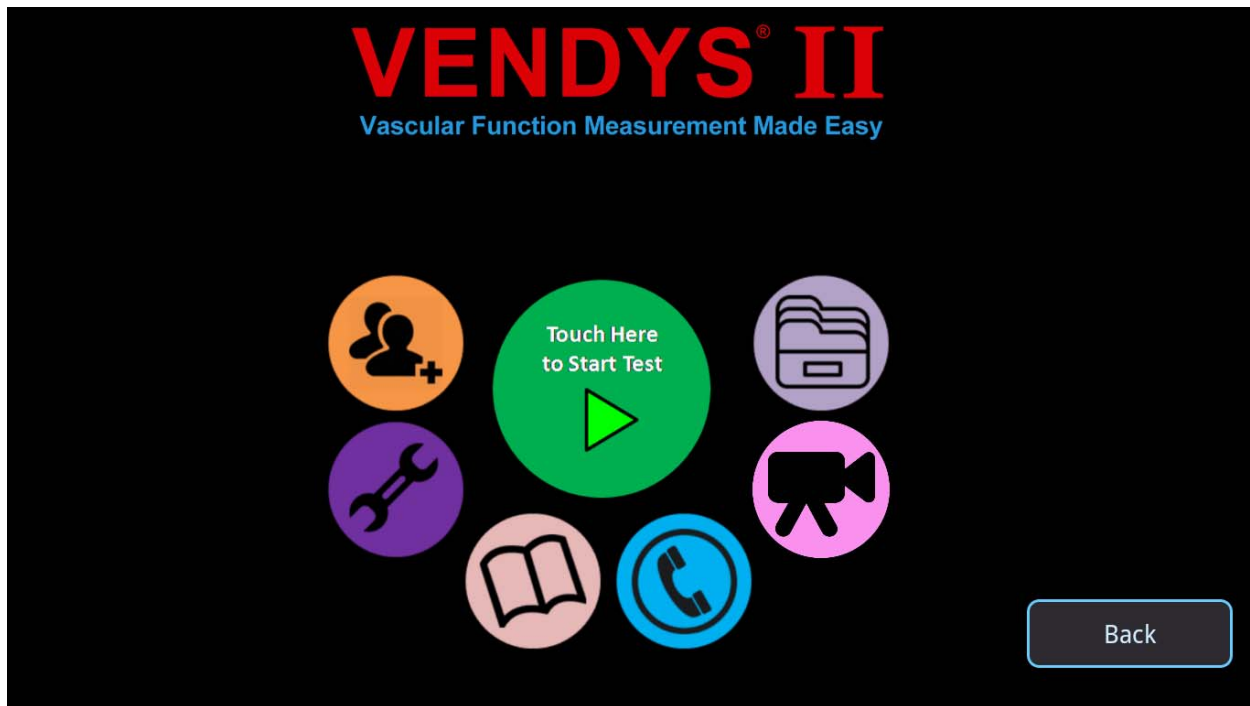

3. Click on “Add Operator” orange button on the left top of the screen, the following page will show up.

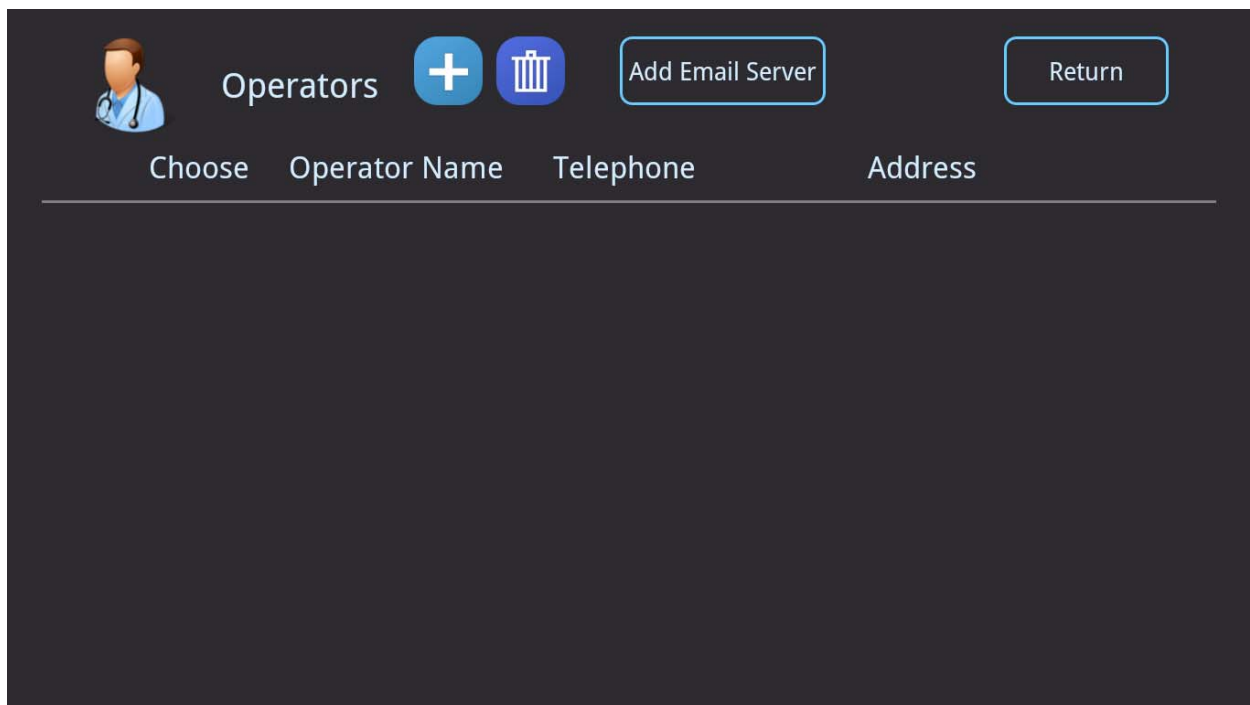

4. Click on the Blue “Plus” button on the left top of the screen, the following page will show up.

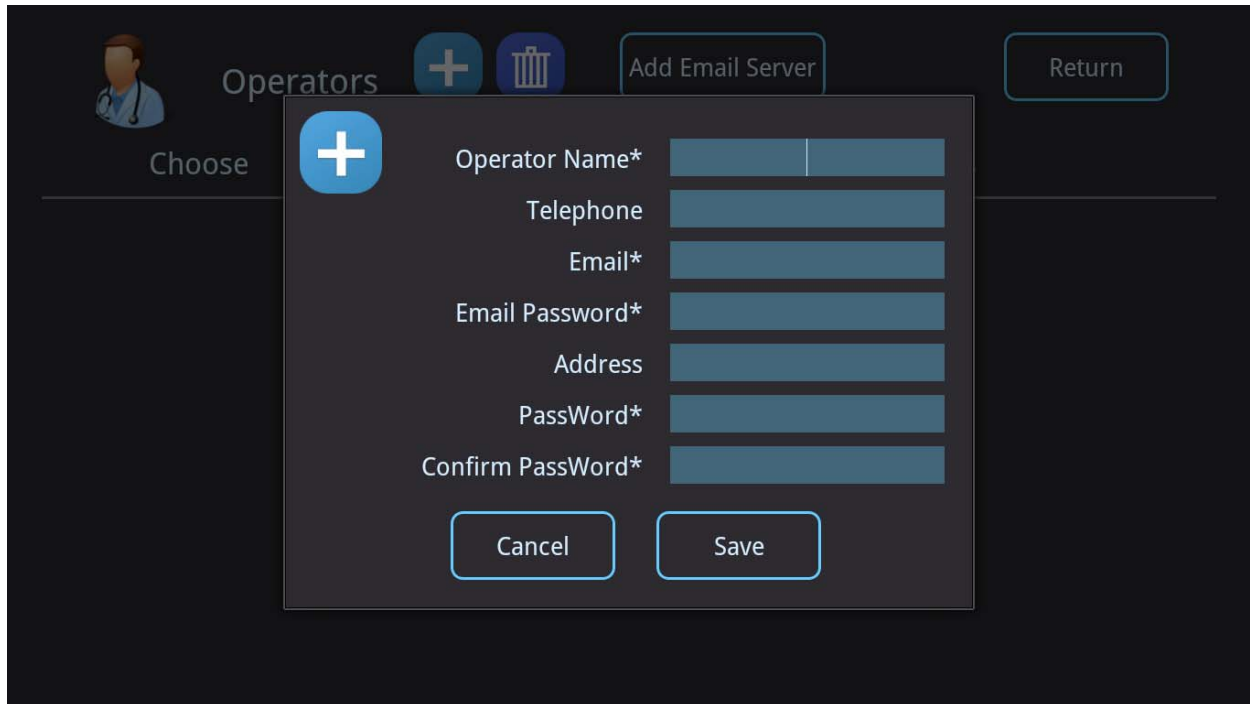

5. Input the required items on the pop-up windows, including operator name, email, email password, operator password, and confirm password. Then Click the “Save” Button.

6. Click on the “Return” button to go back to the Main Page as follows:

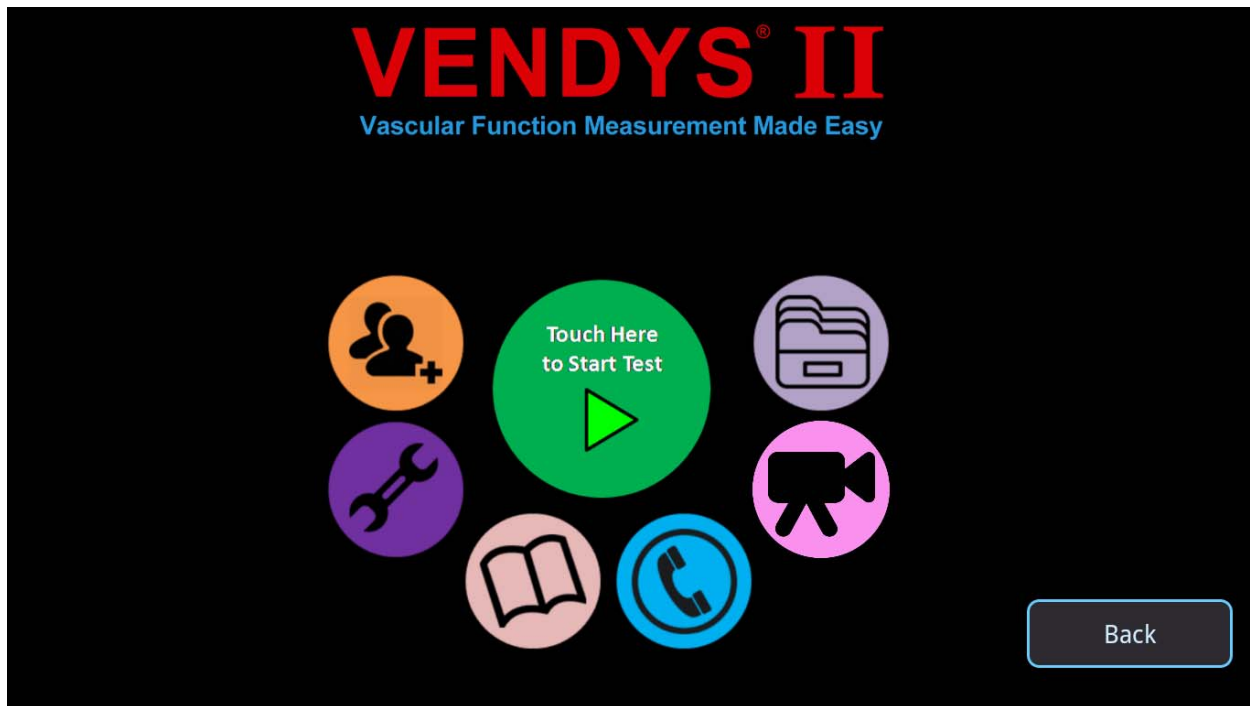

Set up the Name of the Clinic

3. Click on the purple tools icon on the left side of the screen, the following page will show up

Patient number Automatic manual

BP Unit mmHg kPa

Height Unit CM Inch

Weight Unit kg lb

Waist Unit CM Inch

Clinic Information:

Name

Address

Telephone

Email

Website

- 2 Make units selections and input the Clinic information, including name, address, telephone, email, website. And then click on the “Save” button on the top right side of the screen. The name of the clinic will show up at the VENDYS test report.
- 3 Click on the “Return” on the bottom of the screen and go back to the main page.
- 4 Click Back button at lower right side to return to login page. Logout then login as operator.

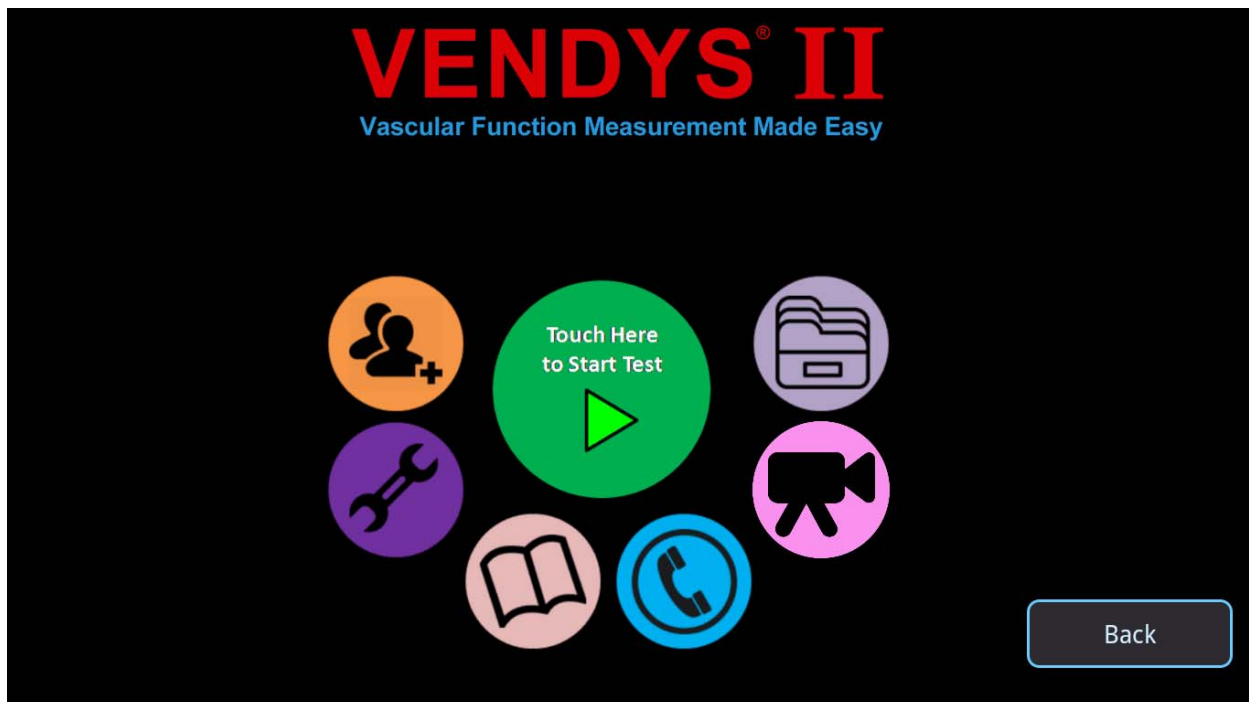

Start a VENDY Test (Login as Operator)

Test Preparation---Optimal Conditions

1. After login as the operator, the following page will show up

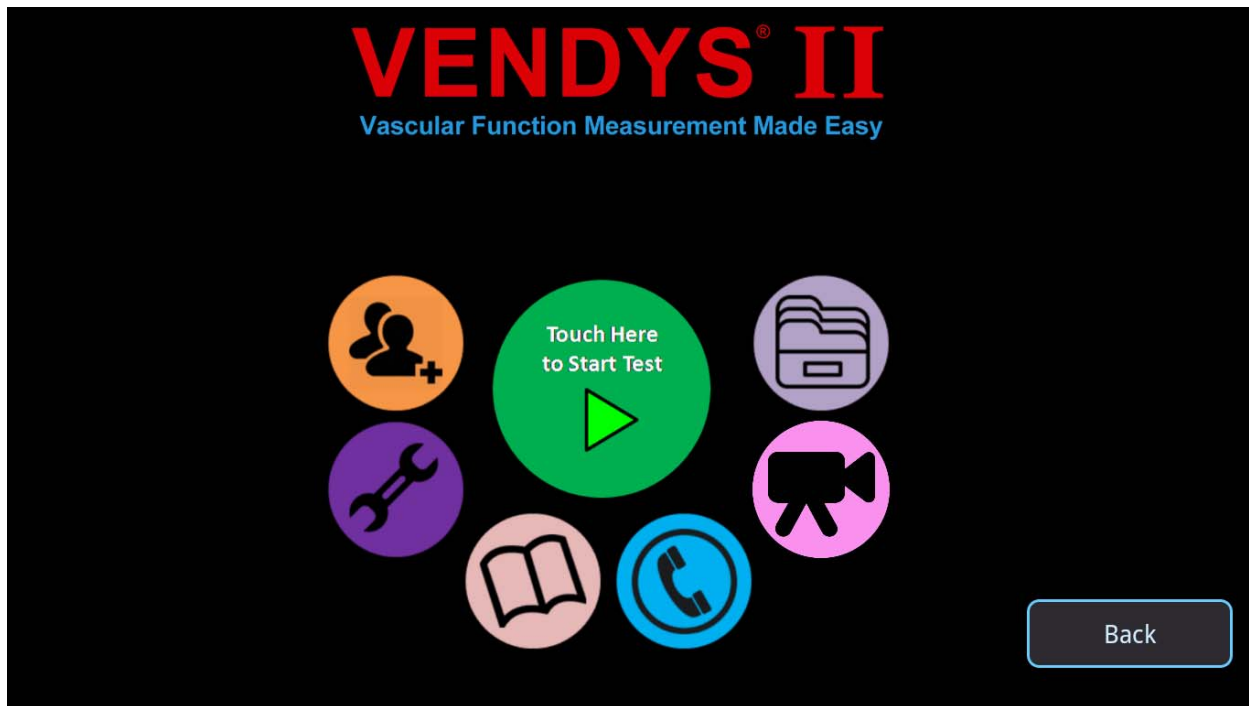

2. After clicking on the green button in the middle, the following page will show up. Choose existing patient/new patient based on your current condition.

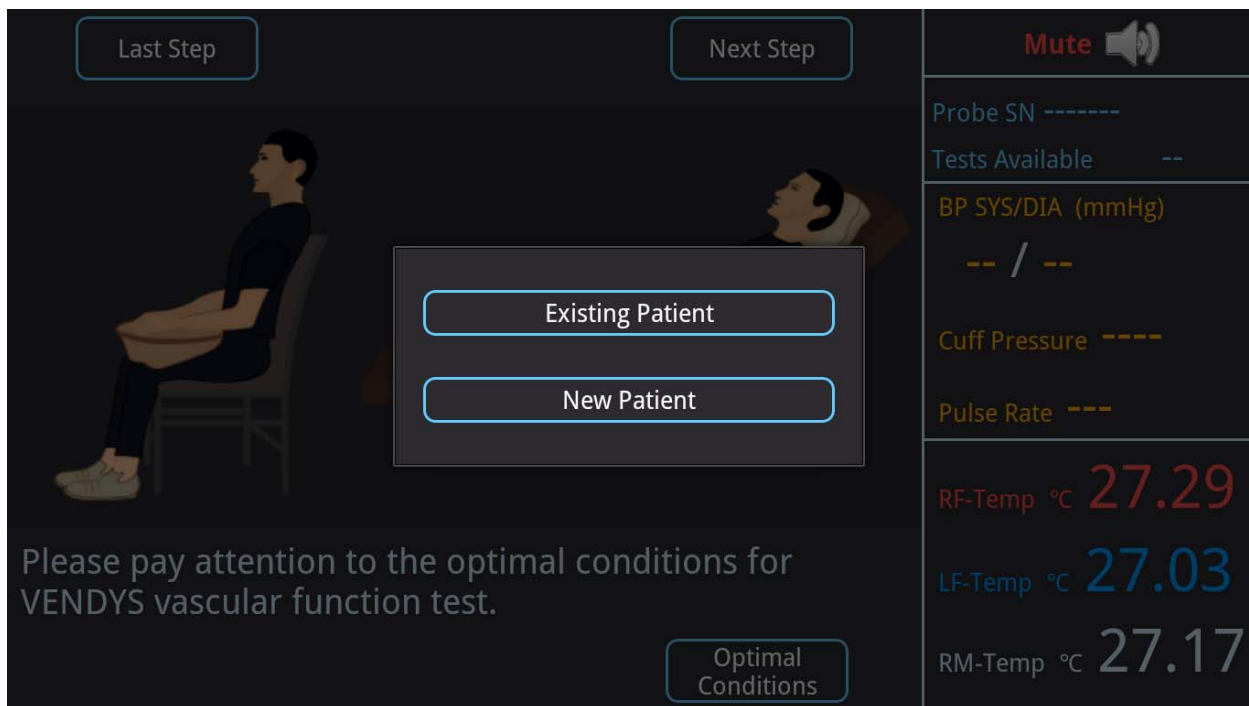

- If an existing patient is chosen, the following page will show up. Scroll up and down to select an existing patient in the system. After clicking on the existing patient, the following page will show up, at the same time, the instructional audio will be played. The instruction audio is “Please sit comfortably with your

hands on the insulated pad either on your lap or to your sides. A reclining chair with arm rests is an optimal position but you may also lie down on a bed. Optimal room temperature is between 22-24 centigrade or 71-75 Fahrenheit. If you feel cold or slightly cold it is strongly recommended to warm up by covering the shoulders and back of the neck with blankets. The room should be quiet and ideally with dim lighting. You should feel relaxed and comfortable. Please pay attention to the next few steps.”

The screenshot shows a dark-themed user interface for a medical device. At the top, there are buttons for 'Last Step' and 'Next Step'. On the right, there is a 'Mute' button with a speaker icon. Below these are fields for 'Probe SN', 'Tests Available', and 'BP SYS/DIA (mmHg)'. The central part of the screen features a table with three rows of patient data, each with a 'Choose' checkbox. Below the table, there is a text instruction: 'Please pay attention to the optimal conditions for VENDYS vascular function test.' and an 'Optimal Conditions' button. On the right side, there are temperature readings: 'LF-Temp °C 27.03' and 'RM-Temp °C 27.17'.

Choose	Patient ID	Patient Name	Date of Birth	Gender
<input type="checkbox"/>	11071303	wendy	2-1-1999	M
<input type="checkbox"/>	11135014	mn	2-1-1999	M
<input type="checkbox"/>	14090261	ag	1-16-1994	M

- If this is your first time running the test, please click on “New Patient”. After clicking on this page, the instruction audio will be played. The audio is the same with existing patient.

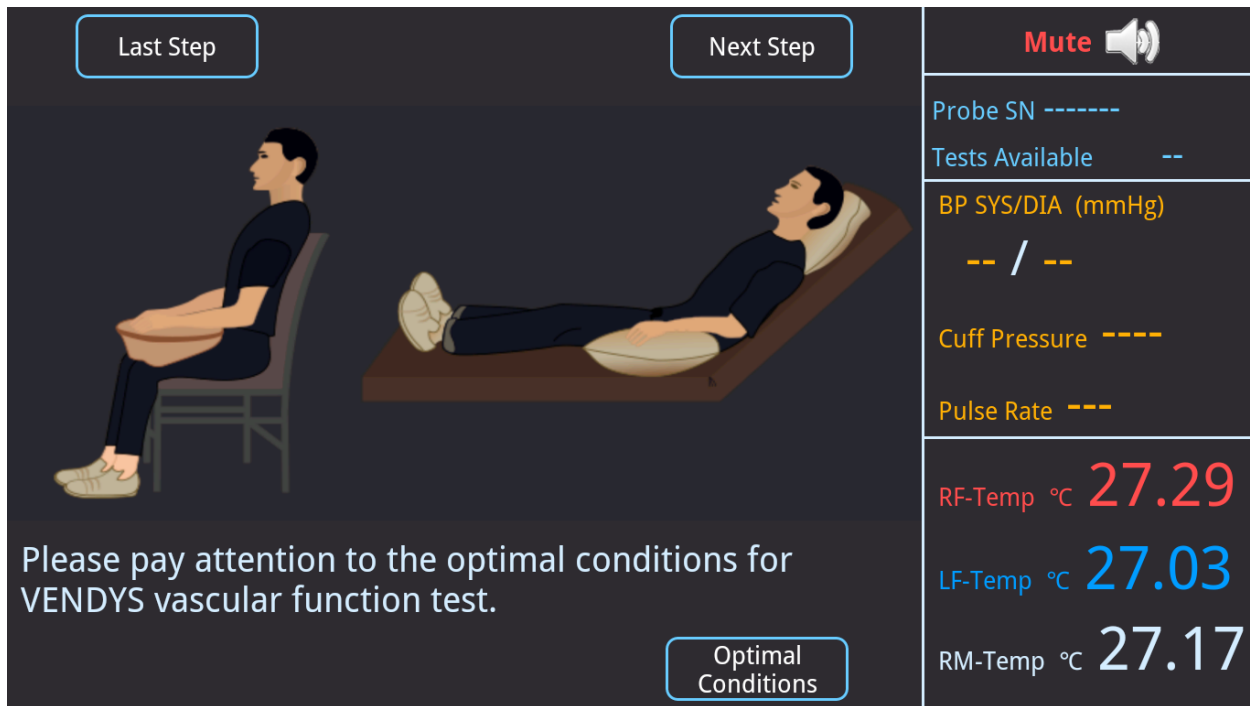

Last Step

Next Step

Mute 

Probe SN -----

Tests Available --

BP SYS/DIA (mmHg)

-- / --

Cuff Pressure -----

Pulse Rate ----

RF-Temp °C **27.29**

LF-Temp °C **27.03**

RM-Temp °C **27.17**

Please pay attention to the optimal conditions for VENDYS vascular function test.

Optimal Conditions

1. Last step: Click here to go back to the previous page of the system
2. Next Step: Click here to go to the next instruction page
3. Optimal condition: Click here to get the text of the audio file.
4. Probe SN: This is the serial number for the attached probe
5. Tests available: This is the number of tests available for current probe
6. Blood pressure information: These values will show up after doing the BP measurement.
7. Temperature:
 - RF-Temp: Right fingertip temperature
 - LF-Temp: Left fingertip temperature
 - RM-Temp: Room Temperature

Finger Size Selection

After clicking on “Next Step”, the following page “Select Finger size” will show up and instructional audio will be played automatically.

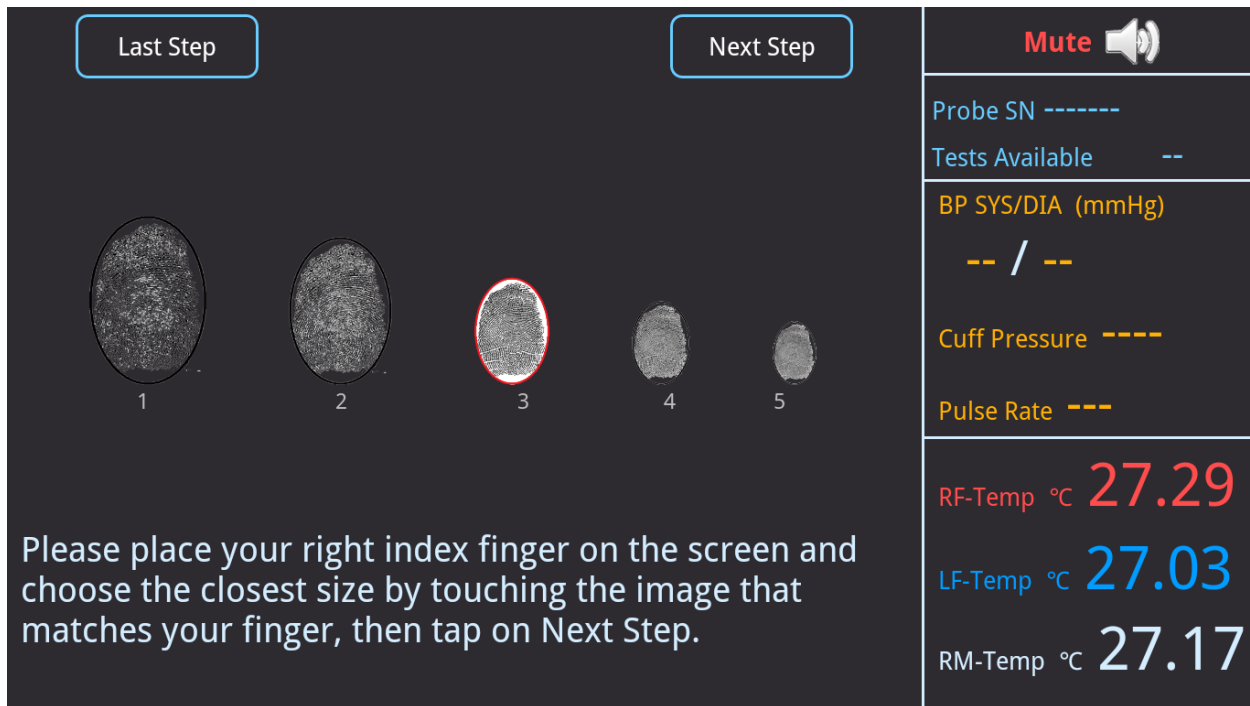

“Please place your right index finger on the screen and choose the closest size by tapping the image that most closely matches your finger. Then tap on “Next step””

1. Last step: Click here to go back to the previous instruction page
2. Next Step: Click here to go to the next instruction page
3. Finger size picture: Place your right index finger on the screen and choose the closest size by tapping the image matches your finger

Cuff Placement

After clicking on “Next Step”, the following page “Cuff Placement” will show up and the instructional audio will be played automatically.

Last Step

Next Step

Mute

Please make sure the cuff is placed properly on the right upper arm and then tap on Next step.

Probe SN -----

Tests Available --

BP SYS/DIA (mmHg)

-- / --

Cuff Pressure ----

Pulse Rate ---

RF-Temp °C 27.29

LF-Temp °C 27.03

RM-Temp °C 27.17

“Please make sure the cuff is placed properly on the right upper arm and then tap on “Next step”.”

1. Last step: Click here to go back to the previous instruction page
2. Next Step: Click here to go to the next instruction page

Subject Temperature Sensor Setup

Attach a disposable adhesive clip to the probe body as follows. Make sure that the raised side of the clip is toward the probe cable



Remove the adhesive covers.



Placing the temperature probes

1. Position the probe on the subject's index finger as follows: Make sure that the center of the probe is located on the pulp of the finger

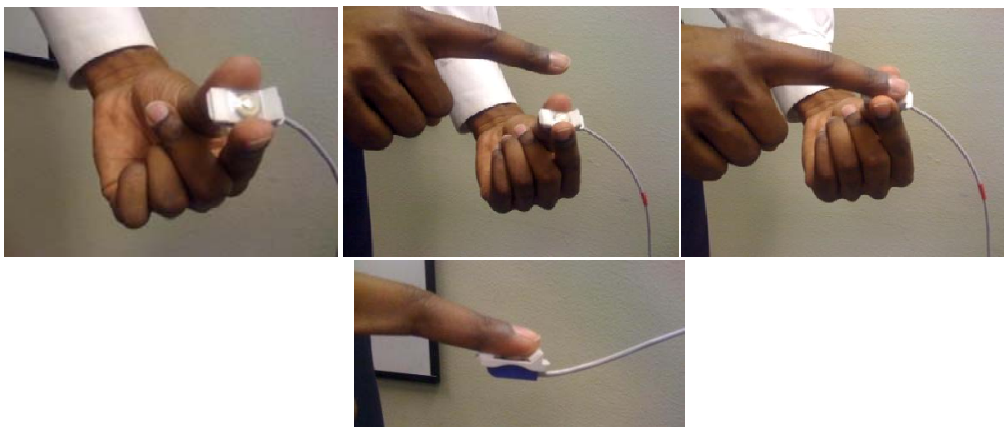

2. Place temperature probe (red tag) on the subject's right index finger
 - a. Probe 1 should always be placed on the occluded arm
 - b. Ensure that the sensor portion of the probe is located on the pulp of the finger.
3. Place temperature probe (blue tag) on the subject's left index finger. Ensure that the sensor portion of the probe is located on the pulp of the finger.

Fingertip Temperature Sensor Attachment

After clicking on "Next Step", the following page "attachment of the probes" will show up and the instructional audio will be played automatically.

Last Step

Next Step

Mute

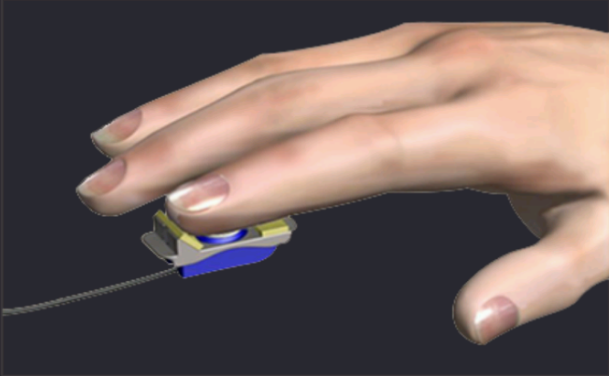



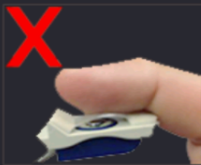

Please attach the temperature probe with red sticker on the right finger, blue for the left finger, and then tap on Next Step.

Probe SN -----

Tests Available --

BP SYS/DIA (mmHg)

-- / --

Cuff Pressure -----

Pulse Rate ---

RF-Temp °C 27.29

LF-Temp °C 27.03

RM-Temp °C 27.17

The instruction audio is “Please attach the temperature probe with red sticker on the right index finger, blue for the left finger. Then tap on “Next step”.”

1. Last step: Click here to go back to the previous instruction page
2. Next Step: Click here to go to the next instruction page

Lap Pad Setup

After clicking on “Next Step”, the following page will show up and instruction audio will be played automatically “put the hands on the insulation pad”.



The instruction audio is “Please put both hands on the smooth side of the insulation pad. This will keep heat from your body and legs not to interfere with the fingertip temperature measurements. Tap on “Next step”.”

1. Last step: Click here to go back to the previous instruction page
2. Next Step: Click here to go to the next instruction page

Patient Demographic and Health Information

After clicking on the “Next step”, the following page will appear to ask you to fill out the patient information and instruction audio for this part will be played automatically.



The instruction audio is “Please select which of these medical conditions are applicable. Check all choices that apply.”

1. Last step: Click here to go back to the previous instruction page
2. Next Step: Click here to go to the next instruction page
3. Main Page: Click on this button to go back to the main page of the system.

4. Notes: Include other medical or basic information which is not included in the list above.

Blood Pressure Measurement

A non-invasive blood pressure test will be performed in this screen. The systolic blood pressure obtained after this screen will be used to determine the inflation pressure of the pneumatic cuff on the right arm during the VENDYS test. The software will add 35mmHg to the systolic blood pressure and the result would be used as the set pressure in the right arm cuff for the VENDYS test. This technique is a safeguard to make sure that the proper occlusion has been reached.

Before doing the blood pressure measurement, please make sure the cuff is placed on the patient arm.

After clicking on the “Next step”, the following page will appear to do the Blood Pressure measurement. The instruction audio will be played automatically, which is “We are about to measure your blood pressure. This step is a standard automated blood pressure measurement. There are 3 different cuff sizes: extra-large, large and small. Please verify that the cuff size is appropriate to your arm size. Please make sure that the cuff is correctly wrapped around the arm: not too tight and not too loose. Please sit or lie comfortably and relax while your blood pressure is measured.”

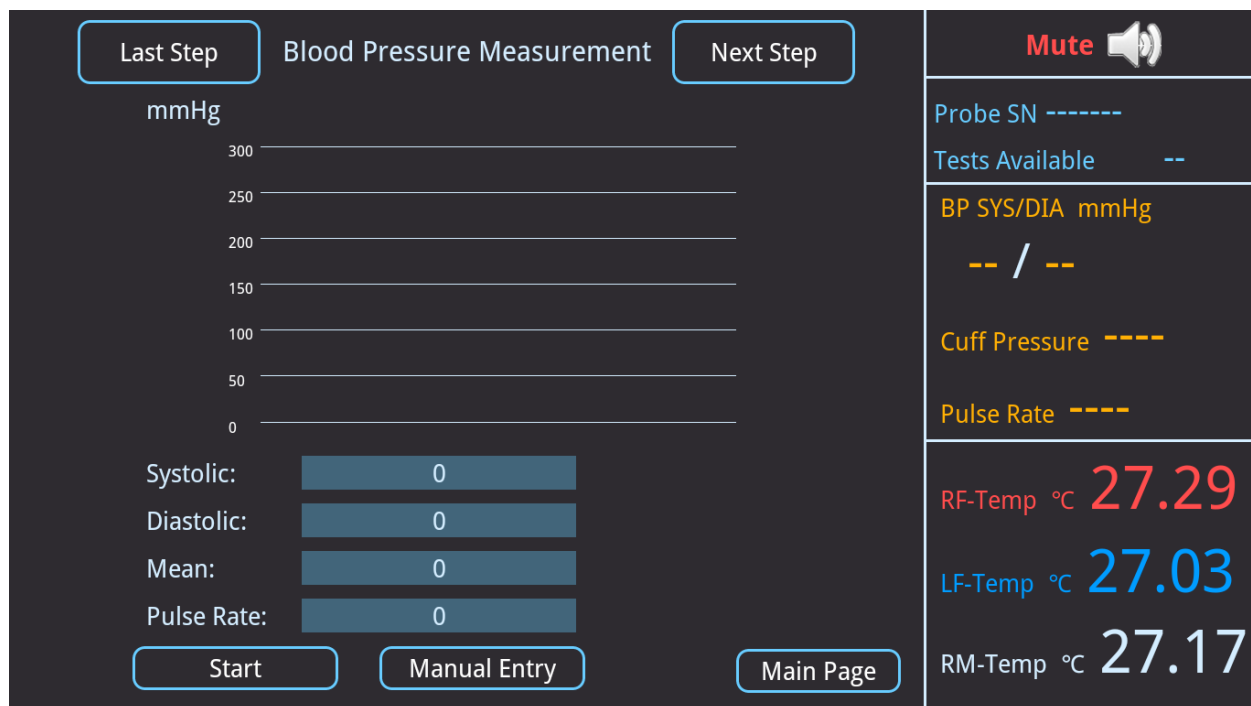

1. Last step: Click here to go back to the previous instruction page
2. Next Step: Click here will allow you to continue on to the VENDYS test once the blood pressure has been calculated or manually entered. This button will not be enabled until the blood pressure is calculated by the blood pressure test or entered manually.
3. Blood Pressure Graph: Displays the graph of the pressure in the cuff over time

4. Start: Click on this button to start the automated blood pressure measurement
5. Manual Entry: If the Manual Entry button is pressed, the blood pressure measurements will have to be taken manually and the results should be input into the program manually in the screen shown later on the page
6. Main Page: Click here to go back to the main page of the system.
7. Blood Pressure Results: When test is complete, this chart will display the systolic pressure, diastolic pressure, calculated mean blood pressure, and pulse rate on the right middle of the screen.

If the manual entry button is clicked, the following screen will appear. The manual Entry button will turn into yellow, which suggests that this feature is enabled. Enter the systolic, diastolic, and then enter the pulse rate. The mean blood pressure will be computed and displayed. Click “Done” on the keyboard to use these results for the VENDYS test. If you change your mind and want to measure your blood pressure using the automatic blood pressure measurement, just click on “Start” to start the measurement.

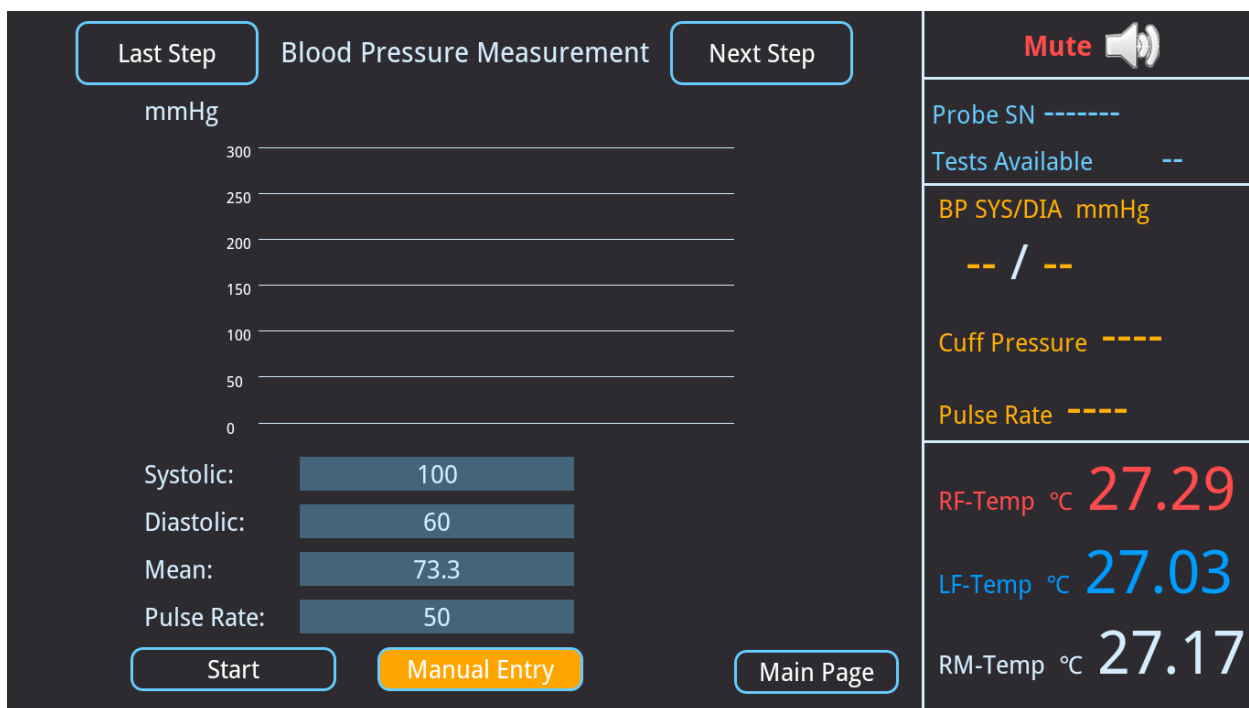

Start the Blood Pressure Measurement

After clicking on the “Start” button at the end of the screen, the blood pressure measurement will be done automatically. And then the following page will show up. The data received from the measurement will show up at the right side of the screen automatically.

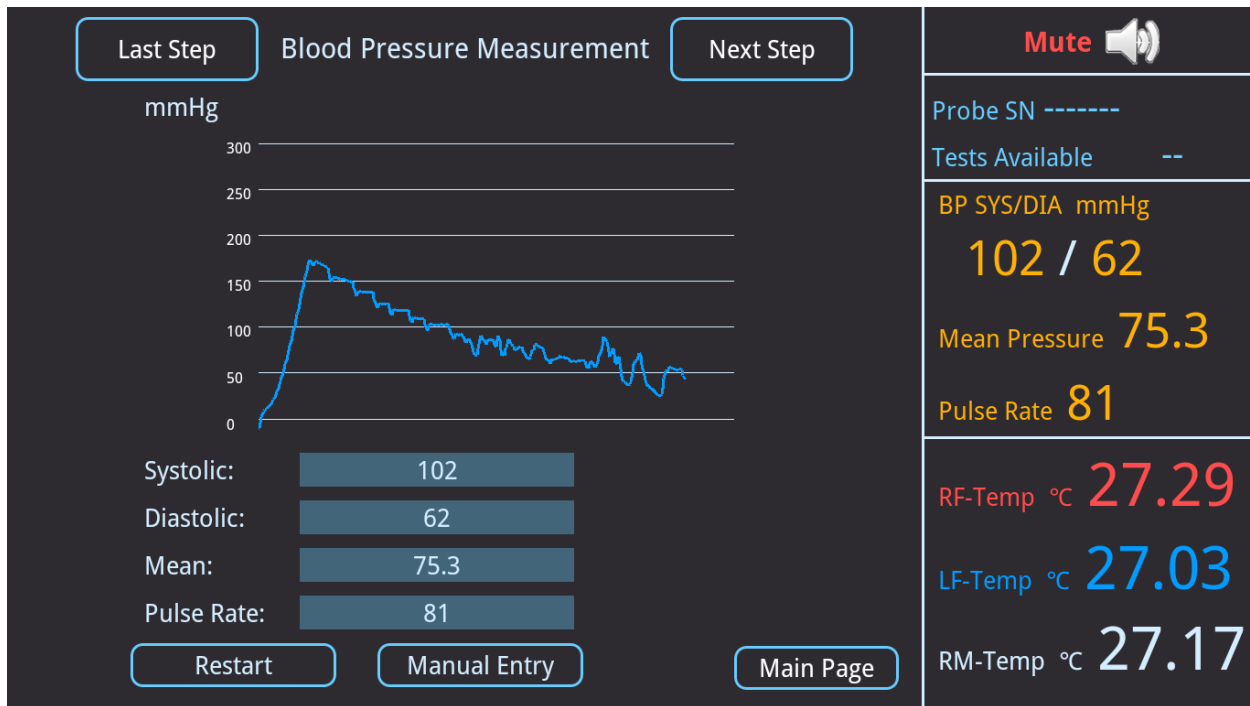

1. Systolic pressure: the systolic pressure of the client
2. Diastolic pressure: the diastolic pressure of the client
3. Mean pressure: the mean pressure of the client
4. Pulse rate: the pulse rate of the client

<p><u>INFORMATION</u></p> 	<p>A blood pressure measurement must be present in order for the VENDYS test to begin and can be calculated using the blood pressure test or the manual entry option. This is because the occlusion cuff will inflate to a pressure of 35 mmHg higher than the measurement to ensure that circulation is stopped. The VENDYS program will not allow the user to continue to the VENDYS test until a blood pressure measurement is submitted.</p>
--	--

VENDYS Vascular Function Test

After blood pressure measurement, clicking on “Next Step” button.

When the “Next Step” button is clicked, the following screen is displayed:

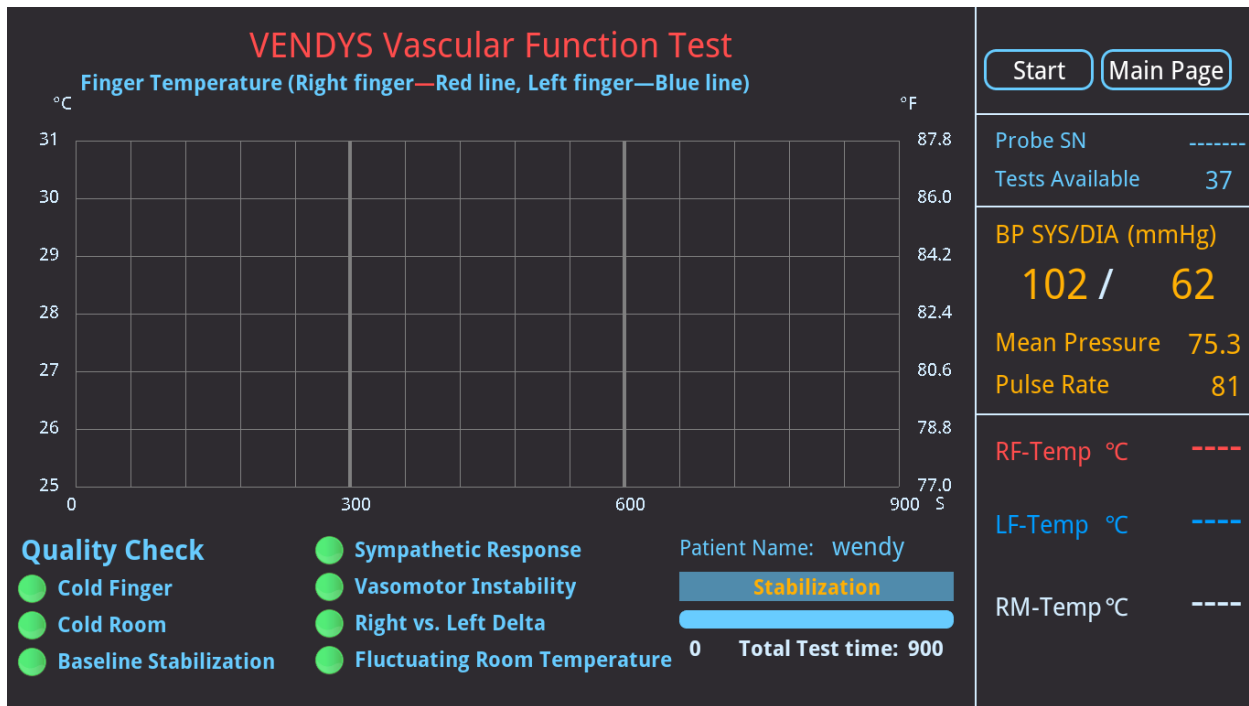

1. Main Page: Click on this button to go back to the main page
2. Start: Click “Start” to allow the VENDYS test to begin
3. Probe SN: Displays the serial number of the temperature probes
4. Test available: Displays the available tests for the current probes
5. Cancel: Stop Test button will show up after clicking on the “Start” Button. If for any reason you wish to stop the test, click Stop Test.
6. Time: This section will display the amount of time remaining within the current phase of the VENDYS test and the time remaining for the whole test to be completed.
7. Temperature Graph: Displays the temperature versus time through the three phases of the VENDYS test. The red trace indicates the right (occluded arm) finger temperature, while the blue trace indicates the left (non-occluded arm) finger temperature. During the three phases of the test, the first five minutes is the stabilization period. The lines for both hands should indicate a stable (nearly flat) baseline and similar temperatures in both hands. During the inflation period, the red line should show a nearly linear temperature drop (after about 30 sec) while the blue line remains nearly constant, indicating a temperature drop in the occluded hand. During the final deflation period, the red line should display a return to baseline temperature after the occlusion is released.
8. Blood pressure measurement results: The systolic, diastolic pressure, mean pressure, pulse rate will be displayed here.
9. Temperature Sensors: Shows the temperature readings as numerical values from the finger probes in real time. The red reading indicates the temperature in

the right, occluded hand. The blue reading indicates the temperature in the left, non-occluded hand. The white reading indicates the room temperature.

10. Flags: Displays any warning flags that may have been activated during the test. (Please refer to Description of Warning Flags section.)

11. Cuff Pressure: Cuff pressure button will show up on the “mean pressure” location after clicking on the “Start” Button, which stands for the cuff pressure on the right arm.

<p><u>INFORMATION</u></p> 	<p>Before beginning the VENDYS test, please review the Subject/ Test Preparation section, to ensure the most accurate results possible in the VENDYS test.</p>
--	---

Start a VENDYS Test

When “Start” is selected, the VENDYS test will begin.

The temperature probes will begin to measure the fingertip temperature and the application will determine the temperature stability based on the input value from the Test Setup form. Once the fingertip temperature stabilizes, the occlusion cuff will inflate to the selected supra-systolic increment. The cuff inflates in about 4 seconds, and the patient’s finger temperature should begin to decline in about 30 seconds.

The numeric values for these readings and room temperature are displayed to the right bottom of the graph. The data is plotted in real time on the auto-ranging chart and stored in a local program array for the final display, storage and analysis.

There are three phases of the test. During the first stabilization section, the lines for both hands should display a stable, flat baseline. In the following occlusion section, the red line for the right hand should display a linear temperature drop, while the blue (left hand) line should remain stable. In the third section, the red line should show a quick return to the baseline temperature after occlusion.

<p><u>WARNING</u></p> 	<p>If at any time during the test, the patient complains about excessive pain or the test needs to be stopped for any reason, both arm cuffs and finger probes should be removed immediately. In addition, pressing the ‘Stop Test’ button will deflate the cuffs and abort the test.</p>
--	---

If any time during the test, the patient complains about the excessive pain or the test needs to be stopped for any reason, both arm cuffs and finger probes should be removed immediately. Pressing the “Cancel” button will deflate the cuffs and abort the test. If the touch screen is not working, please click on the red panic button on top right of the machine to force shut down the machine.



The timers at the bottom of the page will show the time remaining for the phase and the whole test. The software is coming along with the tutorial audio. After clicking on the “Start” button on the screen, the following audio will come out saying “Please close your eyes and try to relax, the test is about to start. You are now in the stabilization phase. This phase will last for 5 minutes. If you are feeling cold please let the operator know.” After the stabilization phase is complete, the program will emit a soft sound to alert the patient that the occlusion phase is about to begin, which is “The occlusion phase is about to start. The cuff is about to be inflated. You are now in the occlusion phase. This phase will last for 5 Minutes. You may feel numbness and tickling in your right hand due to occlusion. These are normal symptoms one experiences during these 5 minutes. Please do not worry and try to relax”. In the middle of the occlusion phase, another audio message will come up and saying “You're half way through the 5 minutes. Please be patient and try to think about your happy moments! Enjoy the music and rest assured the feelings you're having in your right arm and hand will be gone soon after releasing the cuff. ” to assure the patient. 30s away from the end of the second phase, the audio guidance will show up and saying “You are now 30 seconds away from the end of this phase. Please continue to relax”, the same reminder will come up 10s before the end of the occlusion “The cuff will deflate in 10 seconds; please do not move your hands during the deflation phase.”

The guidance sound will be heard after the occlusion phase is complete to alert the patient that the deflation phase is about to begin. “The deflation phase is about to start. The cuff is about to be deflated. ”, After that, “Congratulations! You are now in the deflation phase. This phase will also last for 5 minutes. You will notice your right lower arm and hand may become turning red due to the restoration flow of the warm blood. In fact, there will be more blood rushing to your forearm and hand than the usual. The more blood the more the temperature rebound. After 1-2 min, the redness will disappear and your hand and arm will return to normal. Please relax until the test is completed. It is very important that you feel relaxed in this period which the VENDYS test measures your response.”When the occlusion time has elapsed, the cuff automatically deflates. The program continues to acquire the temperature data and plot it to the strip chart and store it in the local array. This will continue until the PostDeflation Time is reached.

The program tracks these changes as specified by the test settings. Once the test is complete, the program executes several functions:

- Re-plot all the data onto one screen width
- Calculate the various temperature and time values
- Display any warning flags for the test
- Send all information to the database
- Send the entire array of test data to the text data file

Once the test has been completed, the following message will be displayed:

This message indicates that the test is complete and the final report will be created if the test is saved. After clicking on the “View the report” button, the final report will be displayed.

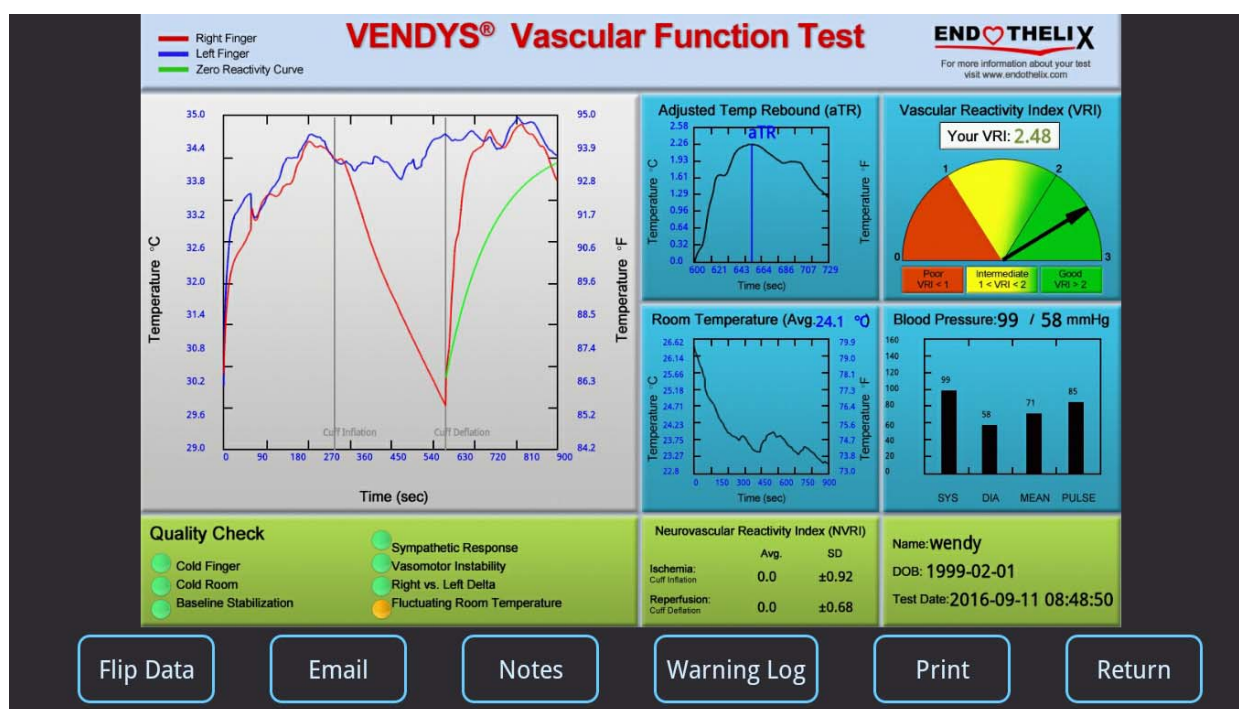

Note: Clicking the Main Page before the VENDYS test is complete will result in the test being canceled and not saved.

Description of WarningFlags

WarningFlags	Description
Cold Finger	<p>This flag is triggered if the right fingertemperature drops below 27°C during the temperature stabilization period. Published literature and our internal testing have indicated that a subject may be in a vasoconstrictive state if the finger temperature declines below 27°C prior to the onset of cuff occlusion. A vasoconstrictive state may adversely affect the assessment of vascular reactivity index.</p> <p>Recommendation: We do NOT recommend saving a test in which this flag has been triggered because the skin surface temperature may not be a</p>

	correct indicator of normal blood flow.
Sympathetic Response	<p>Red flag indicates a constant decrease in the left finger temperature during and after cuff occlusion.</p> <p>This flag evaluates the left finger temperature curve. If the left finger temperature steadily declines after the right arm cuff is deflated, this may indicate that the subject is exhibiting signs of excessive sympathetic nervous activity, which will result in vasoconstriction. When this flag is triggered, we recommend that you evaluate the RIGHT finger temperature curve; if the right temperature curve returns to baseline post-cuff deflation, then the test can be saved. However, if the right temperature curve never returns to baseline, the test should not be saved and the entire test should be repeated at a later time.</p>
Right vs. Left Delta	<p>When triggered, this flag indicates that the temperature difference between right and left fingers is greater than 3°C during the temperature stabilization phase of the test. This may mean that a probe has moved or lost firm contact with the skin surface.</p> <p>Recommendation: Evaluate the position of the temperature probes and make sure the probes are adhering well to the skin surface. If either probe needed to be adjusted, the entire test should be repeated.</p>
Baseline Stabilization	Red flag indicates that the finger temperature never reached a stable value in the time allotted for stability.

	<p>A relatively flat temperature curve during the two-minute time period before cuff occlusion usually indicates stability.</p>
Cold Room	<p>Red flag indicates that the room temperature was below 22 °C for some time during the test. A cold room may cause the subject to enter a vasoconstrictive state, and this may adversely affect the test results. Or The room temperature sensor shows above 32 centigrade or 89.6 Fahrenheit which is not optimal for this test. This flag is raised when the difference between the right finger temperature and room temperature is not sufficient. It indicates that the finger temperature and the room temperature had a difference of less than 3°C. This implies that the right finger temperature does not have enough room to fall during occlusion. This situation could occur in the cases of either a very high room temperature or a low start finger temperature.</p> <p>In this condition, there is not enough temperature difference between fingertip and room. Not enough temperature drop will be created to make sure the test result is accurate.</p> <p>Recommendation: maintain a stable room temperature above 24°C or 75°F and less than 32 °C or 89.6 °F at all times.</p>
Fluctuating Room Temperature	<p>Red flag indicates that the room temperature varied more than 1 °C during the test. This is most often caused by air-</p>

	<p>conditioning turning on. When triggered, this flag indicates that the ambient (room) temperature varied by a large extent during the test. Possible reasons for</p> <p>Fluctuating room temperature include: cold or warm air from an air vent began circulating over the test area; the door to the test room was opened or closed during the test, etc.</p> <p>Significant changes in room temperature may sometimes cause a subject to enter a vasoconstrictive state, causing both right and left finger temperatures to steadily decline.</p>
Vasomotor Instability	<p>This will flag cases where the left finger temperature rises too high due to the vessel open during the whole test.</p>

INFORMATION



Please note that once the patient's name is included on the final report it is permanent. Please review your establishment's patient policies and HIPAA privacy guidelines before deciding whether to add the patient name to the final report.

Elaboration of VENDYS Report

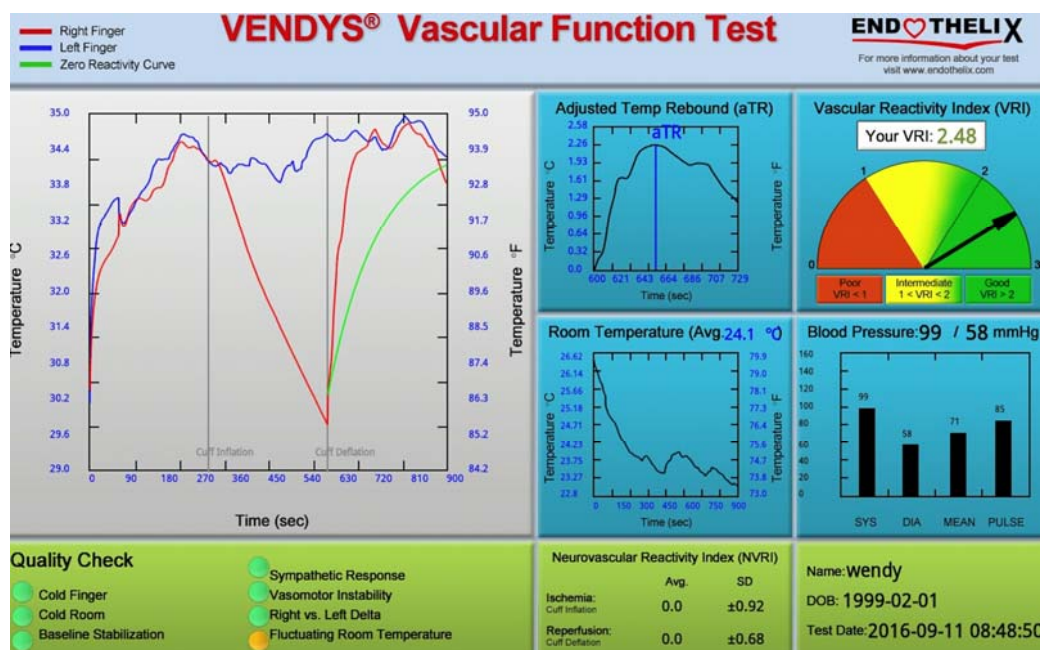

1. Flip Data: Click here to flip the data of both hands. This button is pressed normally when the probes are put on the wrong hands. After pressing this button, the data collected by temperature probes will be swapped. In this case, the patient doesn't have to repeat the test.
2. PrintButton: To produce a hardcopy of the test results once the test is complete, click on the Printable Version button and print the form to a local printer. Any comments will be printed as a second page.
3. Email: To email test results once the test is complete, click on the Email button.
4. Warning Log: Click here to get the history of the warning pop-up windows during the test.
5. Notes: Click button to open a new window to add comments about the test if any. The comments will be saved as a metadata in the image once the home button is pressed. The comments can be viewed at the Completed Test Viewers screen.

6. VENDYSReport: Completed VENDYS report displays the final temperature graph, the vascular reactivity index and its representation, the blood pressure and pulse details, the room temperature during the course of the test, the zero reactivity curve, the graph of the adjusted reactivity curve, any flags and other details about the completed VENDYS test. (See the VENDYS Report section.)
7. Return: Click on this button to go back to the main page of the VENDYS software.

1. Flip Data

After clicking on the “Flip Data”, the following pop-up window “Do you confirm to flip data” will show up.

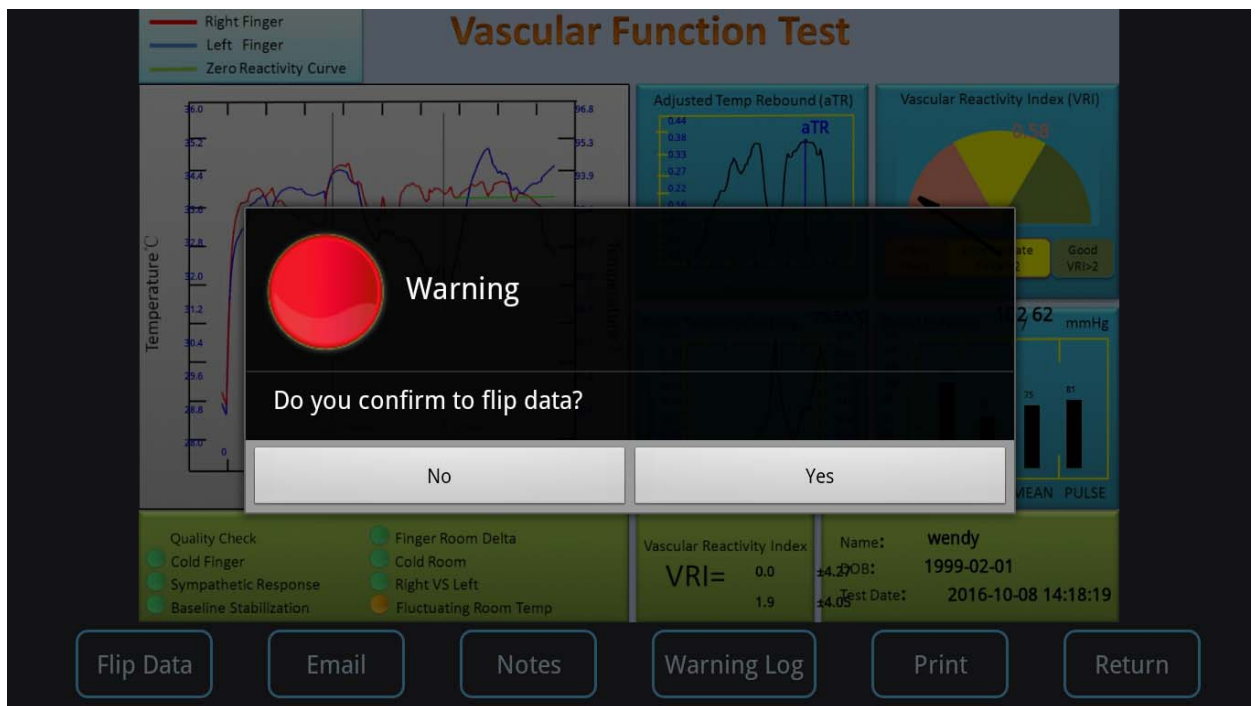

1. Yes: Click here to confirm to flip the data

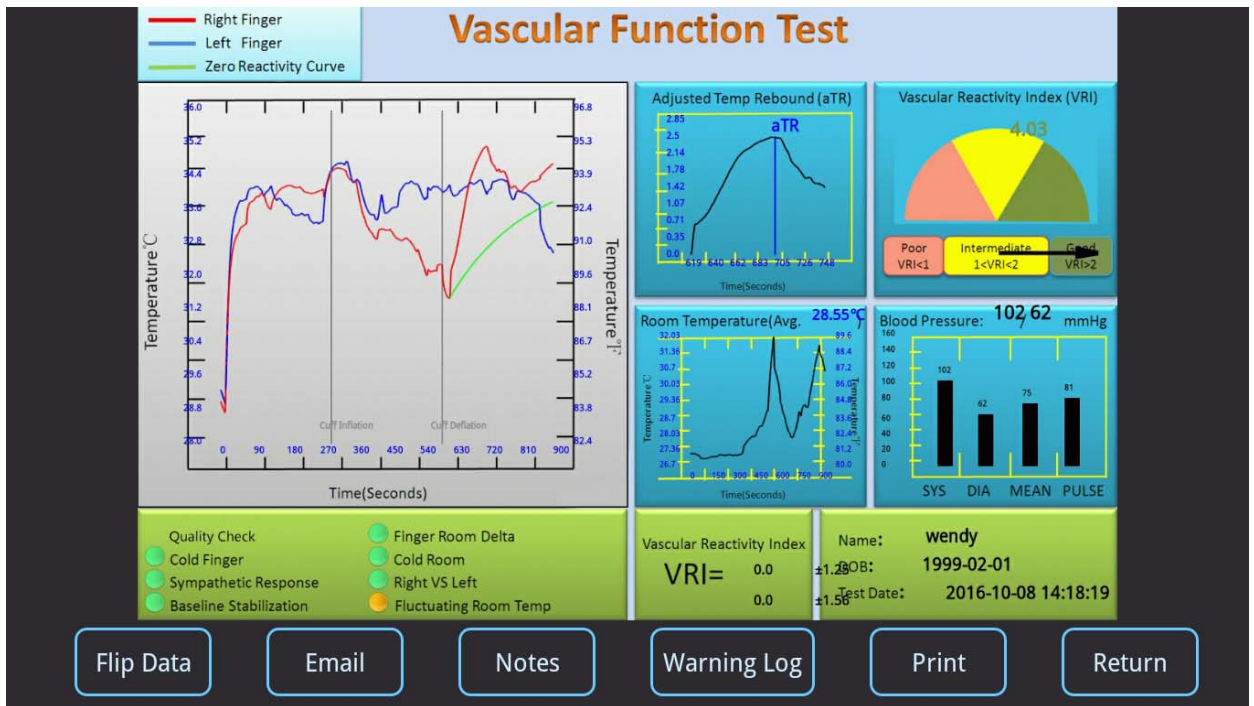

2. No: Click here to notswapthe data

2. Print

After clicking on the “Print” button, the following page will show up

3. Email:

After clicking on the “Email” button, the following page will show up

Return Send email Send

Receiver:

Cc:

Sender: VENDYS-II@endothelix.com

Subject: VENDYS Test Report

Hello, please see the VENDYS test report in the attachment.Thanks!

Please see the instruction XX part to learn more details about how to send VENDYS testReport

4. Warning Log

After clicking on the “Warning Log” button, the following page will show up.The warning pop-ups are saved in this page to describe what happened during the test.

Warning Log

Dismiss fingertip probe detachment flag	08-10-2016 14:03:43
Dismiss fingertip probe detachment flag	08-10-2016 14:05:18
Dismiss fingertip probe detachment flag	08-10-2016 14:07:07
Increasing rate of cuff pressure is too high	08-10-2016 14:07:12
Dismiss fingertip probe detachment flag	08-10-2016 14:07:40
Dismiss fingertip probe detachment flag	08-10-2016 14:08:03
Dismiss fingertip probe detachment flag	08-10-2016 14:08:21
Dismiss fluctuating room temperature flag	08-10-2016 14:08:25
Dismiss fingertip probe detachment flag	08-10-2016 14:09:16
Increasing rate of cuff pressure is too high	08-10-2016 14:10:33
Dismiss fingertip probe detachment flag	08-10-2016 14:10:33
Dismiss fingertip probe detachment flag	08-10-2016 14:10:41

5. Notes

After clicking on the “Notes” button, the following page will show up

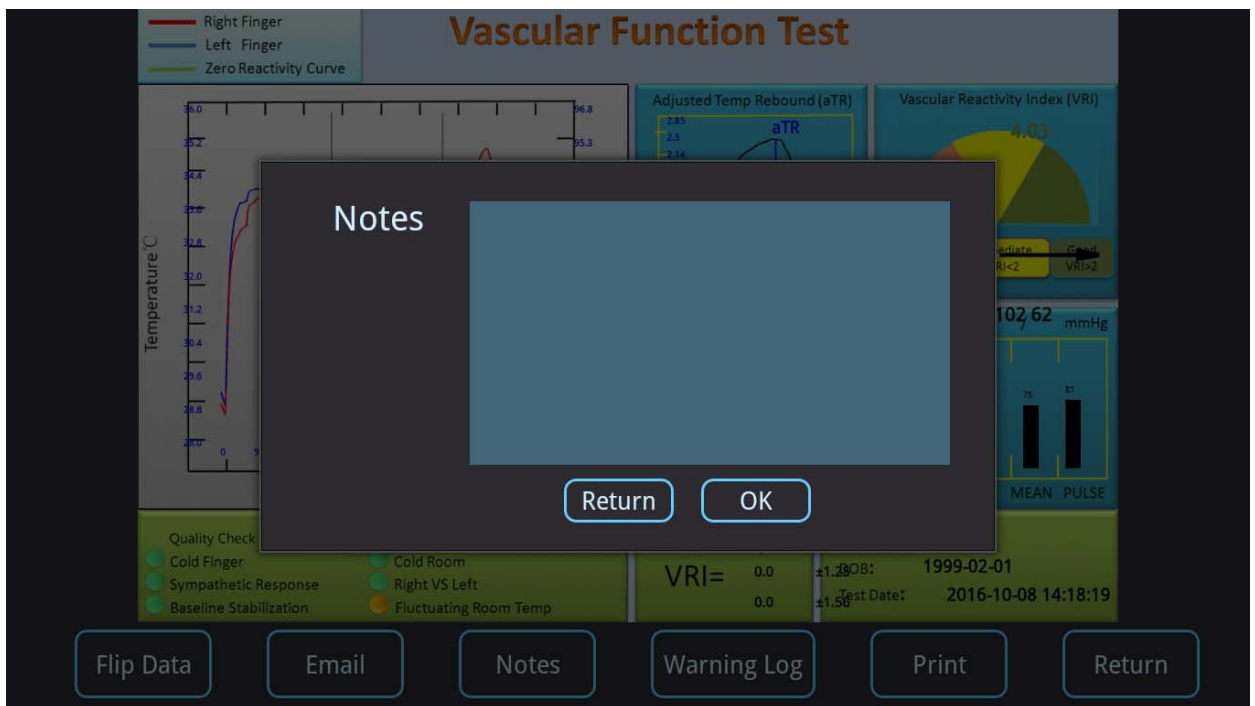

1. OK: Press this button to save the notes made here

- Return: Click on this button to return to the test report without saving the notes made here.

6. VENDYS® Report

<p>Temperature Graph:</p>	<p>Displays temperature graph of VENDYS test. The legend above indicates that the right bold line is the right hand, and the blue bolded line is the left. The green line indicates the zero reactivity curve, the expected temperature increase if there was no vasodilation. The red vertical lines separate the different phases of the test. The red horizontal lines mark the minimum temperature reached and the start temperature at the time of inflation. Directly above the graph is the filename that will appear in the list of studies in the completed test viewer</p>
<p>Warning Flags:</p>	<p>Displays any warning flags that may have been raised in red. (Please refer to the “Descriptions of Warning Flags” section.)</p>
<p>Adjusted Reactivity Curve:</p>	<p>This temperature graph displays the adjusted curve of the difference between the zero reactivity curve and the observed temperature rebound in the occluded arm. The final report aTR is the maximum value in this graph.</p>
<p>Vascular Reactivity Index:</p>	<p>Displays a general reading of cardiovascular health based on the level of the final aTR value: an aTR below 1 is considered to show poor cardiovascular reactivity, whereas an aTR of between 1 and 2 is considered intermediate, and an aTR of more than 2 is considered healthy.</p>

Room Temperature Graph:	This graph displays the fluctuations in room temperature during the testing period. A flag may be raised if the room is cold or the room temperature fluctuates. (Please refer to the “Descriptions of Warning Flags” section.) In addition, if sympathetic behavior is present, it may be due to fluctuating room temperatures. If this occurs, it can be confirmed by looking for similar behavior in the room temperature graph. For instance, temperature decreases in the non-occluded hand may be due to air conditioning cycles and this would be represented as a temperature decrease in the room.
Blood Pressure and Pulse:	This graph displays the measurements taken during the blood pressure section. It shows the systolic, diastolic, and mean pressure as well as the measured pulse.
aTR Value:	The gauge indicator displays the final aTR (adjusted temperature rebound) value. The aTR value magnitude directly correlates with the extent of the subject’s vascular reactivity.
NVRI Value	XXXXXX
Name, Date and Time	Displays the name of the patient, date and time that the test was taken at.

7. Return:

When finished with this screen, clicking “Return” will return the user to the Main Page of VENDYS test.

VENDYS II Graphic User Interface

Login Page

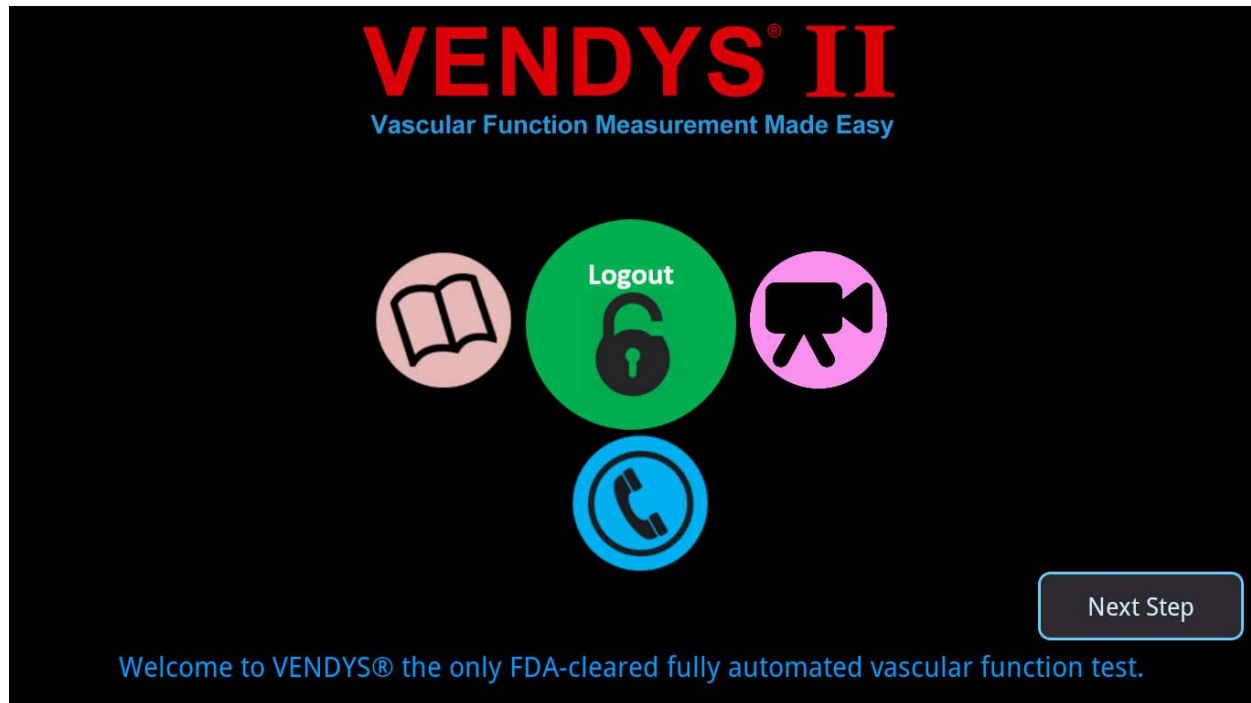

1. Login: press the “green icon” in the middle of the screen, to input username and password, you will then enter into the system successfully. If the icon indicates “Logout”, someone is already logged in. Simply press the icon to log them out, then press again to proceed.
2. Video Gallery: Several tutorial videos are included behind this button, which will give a better understanding about the test.
3. Tutorial: User guide and VENDYS II Web Page information will be provided in this section
4. Contact Us: Click here to find the customer support contact and company information.
5. Next Step: Use “Next Step”, only if you are already logged into the system (green button indicates “Logout”).

Login

1. After clicking on the green “Login” button in the middle of the login page, it will lead you to the following login page. There are three options for the customer to choose.
 - a. Superadmin: this is for the Endothelix technical support
 - b. Admin: this is for the administrator of local clinic, the operators can be added via this account

- c. Operator (This option will show up after adding operators on the following main page and is the normal choice after setup)

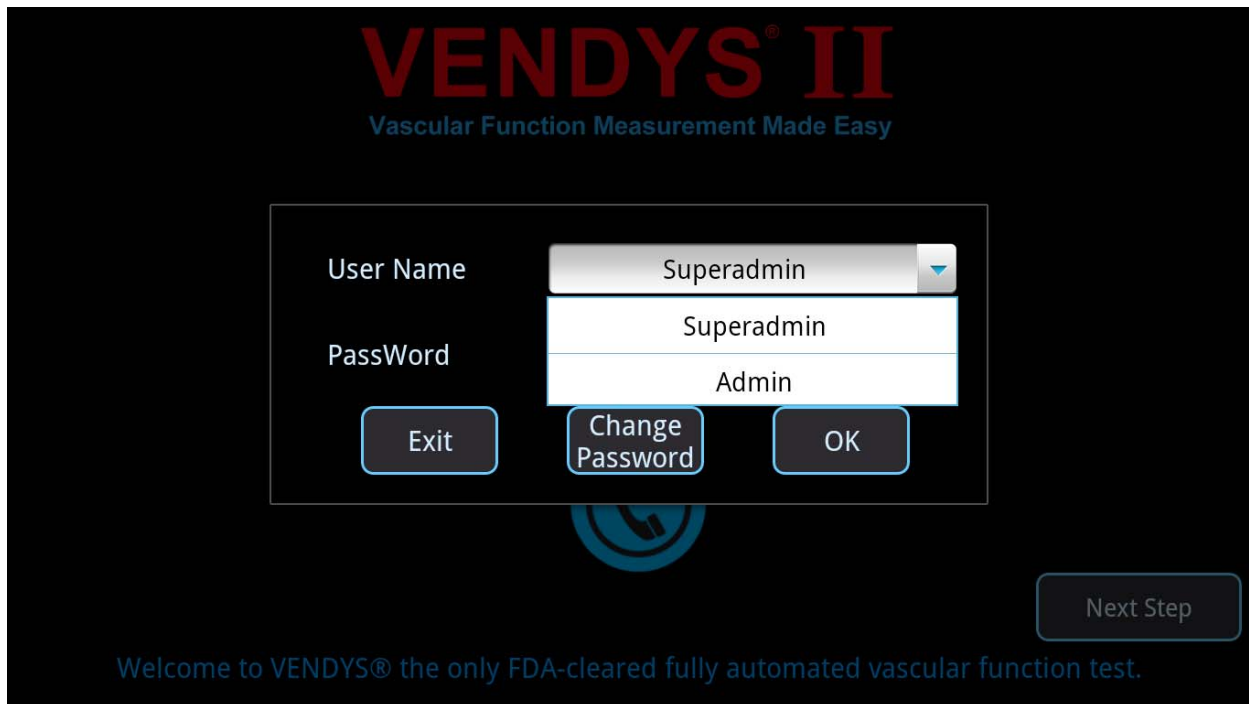

2. Choose the “admin” as the “User Name”. The default password for “Admin” is “888888”.
- OK: After entering the password for “Admin”, click on “OK” button to go to the operation “Main Page”.
 - Change password: You can change your password by clicking on the “Change Password” button right under the password column.
 - Exit: After clicking on “Exit” button, the device will lead you back to the previous login page.

Video Gallery

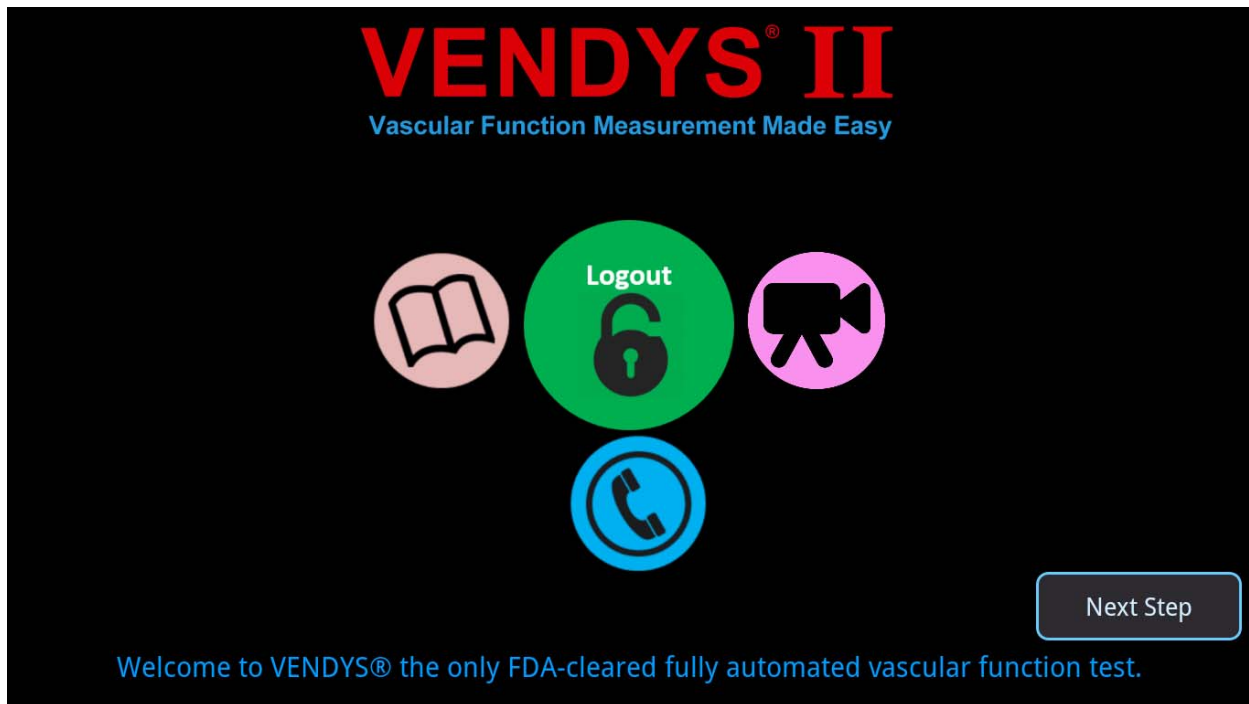

After clicking on the pink videogallerybutton shown on the screenshot picture above, the following picture appears.



1. The title for this session.

2. Tutorial video list: These videos will give a detailed introduction to VENDYS vascular function test and the principle behind it.

Tutorial

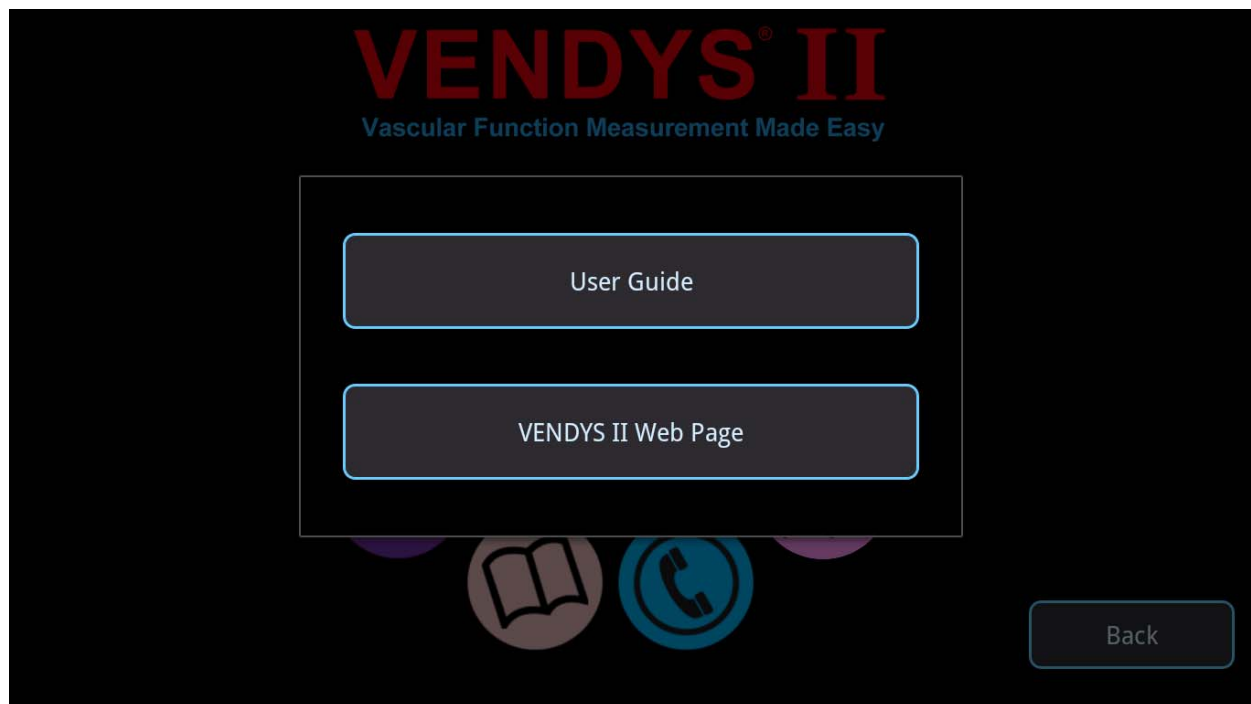

1. User Guide: 5 useful documents are included behind this link, which will give a detailed introduction to the VENDYS test and:
 - VENDYS Quick Guide
 - Instruction Manual
 - VENDYS Brochure for Physician
 - VENDYS Flier for Patient
 - Test Report Explained
2. VENDYS II Web Page: Most recent/updated information can be gained under this button. You still can find more information via this link www.endothelix.com/vendys-II

1. User Guide

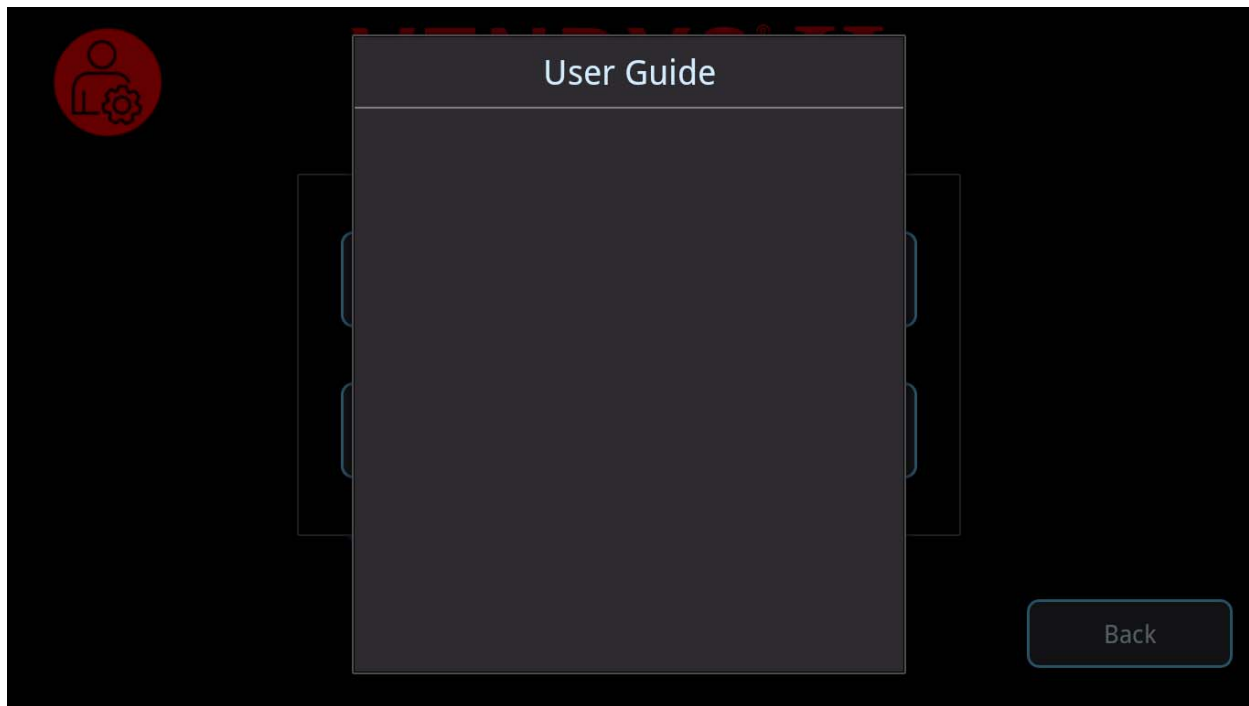

1. Title
2. Tutorial PDFdocuments. These documents will give a detailed introduction to VENDYS vascular function test method
 - VENDYS Quick Guide
 - Instruction Manual
 - VENDYS Brochure for Physician
 - VENDYS Flier for Patient
 - Test Report Explained

VENDYS II Web Page



VENDYS II Web Page: Most recent/updated information can be gained under this button. You still can find more information via this link www.endothelix.com/vendys-II

Contact Us



Contact Us (The blue telephone icon): Click here to find out the customer support contact and company information.

VENDYS II Main Page

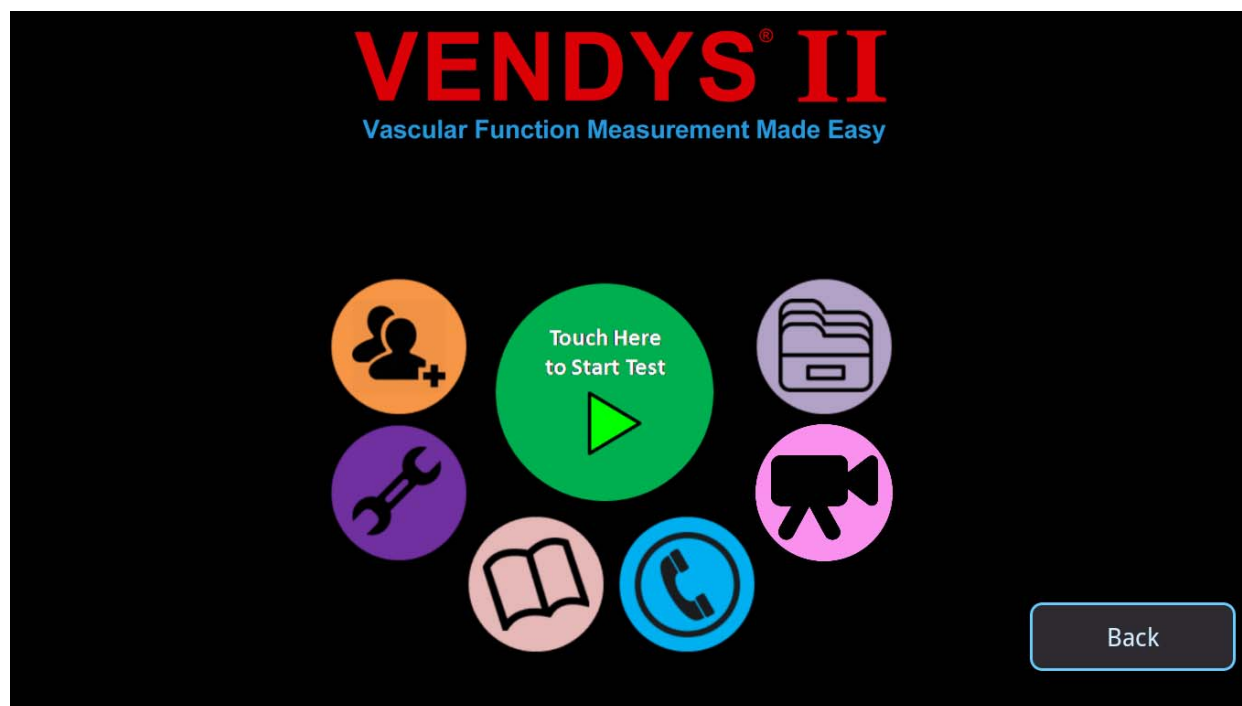

1. “Touch here to start” button: After clicking on this button, several tutorial instruction will be given to show you how to prepare for the test, and a few basic and health questions will be asked before doing the VENDYS test.
2. “Add Operators” button: Operators information can be added via this link. The difference between operator and admin is that, admin has the access to “Add operator”and “Setting”. But operator doesn’t.
3. “Setting” button: The customer can personalize some changes while doing their VENDYS test
4. Local file: User guide and VENDYS II Web Page information will be provided in this section
5. Contact Us Button (The blue telephone icon): Click here to find out the customer support contact and company information.
6. Video galleria: A brunch of tutorial videos are included behind this button, which will give a better understanding about this test.
7. Patient folder: The tests results will be saved in this folder after tests are done.

Add Operators

After clicking on “Add Operator” button, the following page will show up.

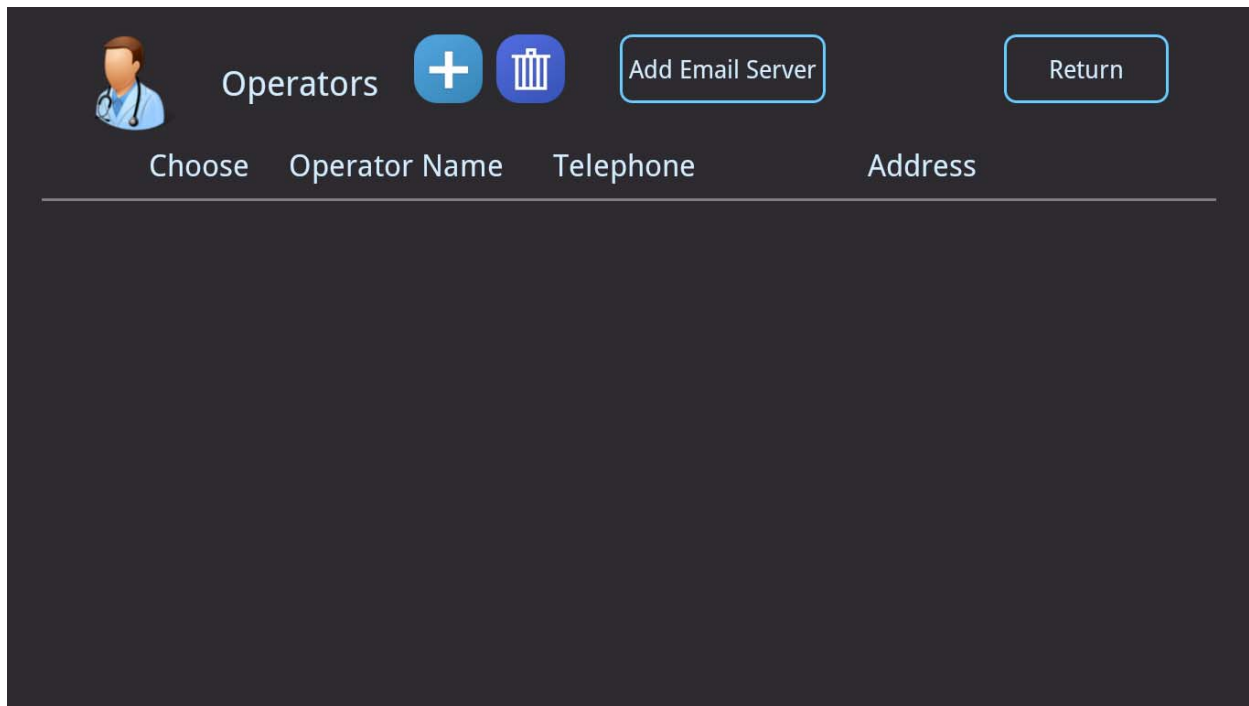

1. The title for this page
2. Plus button: the admin can add operator information via clicking on plus button.
3. Add Email Server: Adding additional email server can help add operator's email address under the "Add operator" session.
4. Trashcan button: After checking the box in front of the specific operator, and then pressing on the "Trashcan" button, all the information concerning this specific operator will be removed.
5. Return: The user will go back to the Main Page after clicking on the "Return" button.
6. Plus Button: adding operator

Plus Button

After clicking on the "Plus" button, the following page will show up. The items followed by the star mark are required for the operators

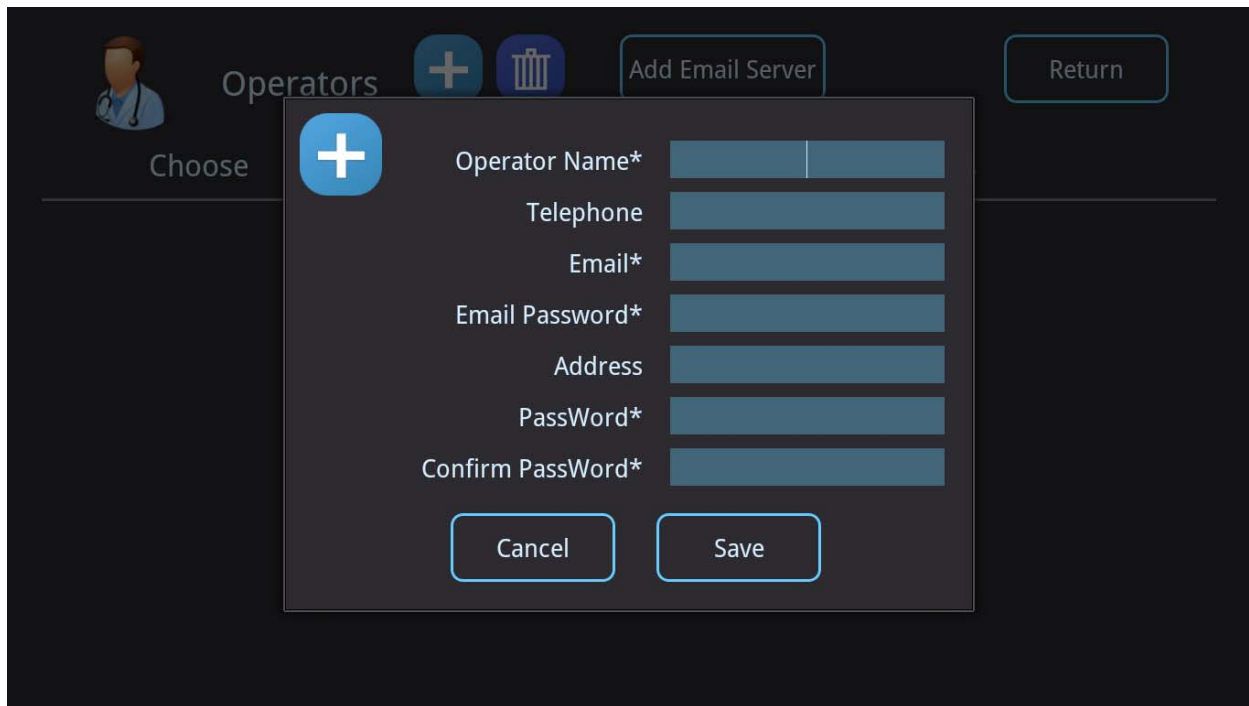

1. Operator Name: Entering the operator name in blank after “Operator Name”. This is required item.
2. Telephone: This is optional
3. Email: This is required item, which will be used to send test report to the patient
4. Email password: This is required item, which is necessary for the verification of the email address entered above.
5. Address: This is optional.
6. Password: This password is used for the previous login page
7. Confirm Password: Please enter the exact same password as the one you enter above

Add email server

After clicking on the “Add email server” button, the following page will show up. If your commonly used email doesn’t fall into these categories, please click on the plus button on the right top of the screen to add your email server.

Choose	server name	server host	server port
<input type="checkbox"/>	gmail	smtp.gmail.com	465
<input type="checkbox"/>	yahoo	smtp.mail.yahoo.cn	465
<input type="checkbox"/>	icloud	smtp.mail.me.com	465
<input type="checkbox"/>	Outlook.com	smtp.live.com	25
<input type="checkbox"/>	exchange	smtp.xxx.com	465
<input type="checkbox"/>	Aol.	smtp.xxx.com	465
<input type="checkbox"/>	endothelix	smtp.endothelix.com	25

- 1) Plus Button: the admin can add server information via clicking on plus button.
- 2) Trashcan button: After checking the box in front of the specific email server, and then pressing on the “Trashcan” button, the selected email server will be removed.
- 3) Return: The user will go back to the “Add Operator” page after clicking on the “Return” button.

1) Plus Button

After clicking on the “Plus” button on the right top of the screen, the following page will show up, please enter the server name, for example: “XXXX”. And then click

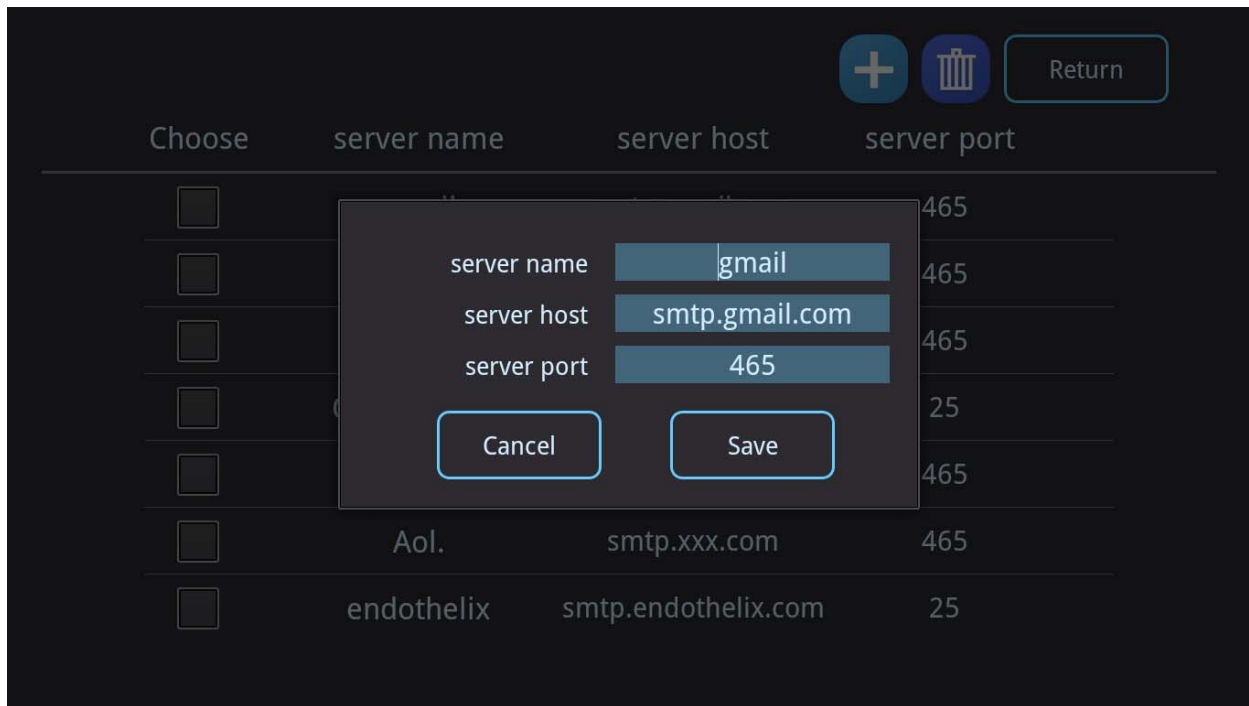

on the “Save” button. The new server will be saved.

Settings

After clicking on the “Setting” on the Main Page, the following page will show up.

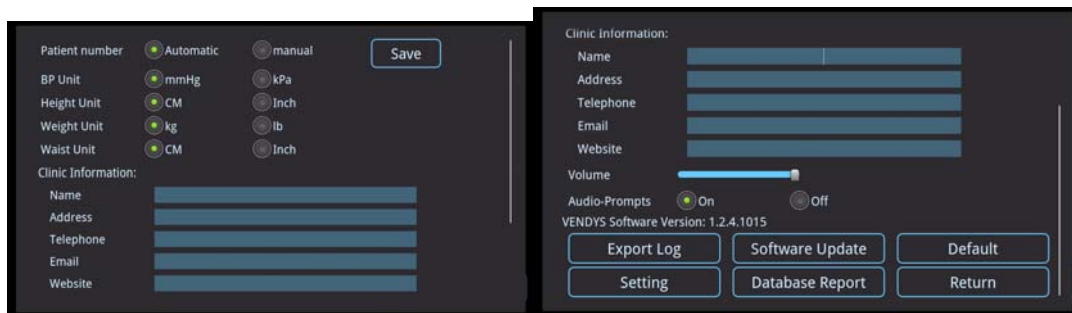

1. Patient Number: a unique sequence of numbers will be generated for each patient. You can use unique numbers generated by the system automatically or you can create your own unique numbers for the patients in your clinic manually.
2. BP Unit: The unit for blood pressure, there are two options for that. One is mmHg, the other is Kpa. Please choose the one you feel comfortable with.
3. Height Unit: The unit for height, there are two options for that. One is cm, the other is inch. Please choose the one you feel comfortable with.
4. Weight Unit: The unit for weight, there are two options for that. One is kg, the other is lb. Please choose the one you feel comfortable with.
5. Waist Unit: The unit for waist, there are two options for that. One is cm, the other is inch. Please choose the one you feel comfortable with.

6. Medical information: enter the medical institution's name, address, telephone, email, and website. The medical institution's name will show up at the patient's report, which suggests the patient gets tested in this clinic.
7. Volume: The volume of the device can be adjusted down by moving the little grey bar from the right to left.
8. Audio-Prompts: the audio can be adjusted to the highest if the "On" button is pressed. While the audio will be totally turned off once "Off" button is pressed.
9. Setting: Other settings like Ethernet, WIFI, Bluetooth, Date&Time, Display &Volume, and Printer.
- 10.Database Report: All the patient tests data can be exported via this link.
- 11.Export Log: All the warnings during the test will be saved in this log for remote troubleshooting
- 12.Update: The current program can be updated via clicking on this button
- 13.Save: Any change is made, this button has to be clicked on to save the changes user makes.
- 14.Default: If user wants to set everything in the setting section as the factory setting, please click on default button.
- 15.Return: After clicking on this button, the system will lead you back to the Main Page.
- 16.Software version: The version number is followed by the software version.

9. Setting

After clicking on the "Setting", the following page will show up.

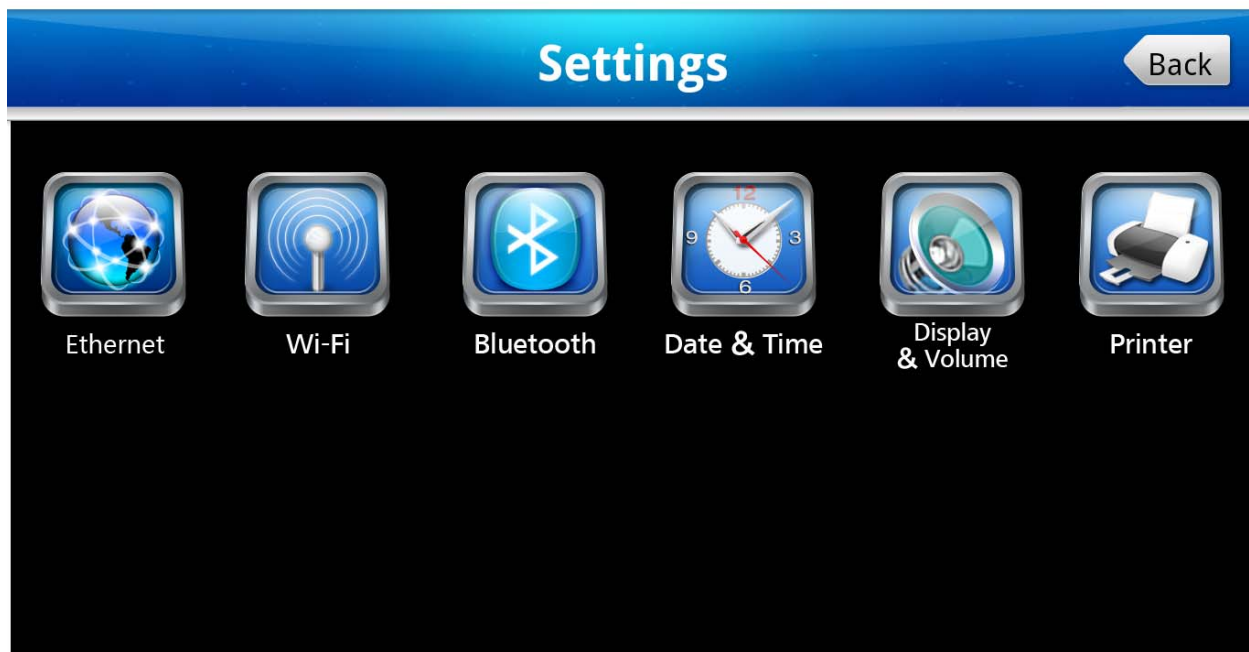

- 1) Ethernet: Ethernet can be set up via clicking on this button.
- 2) WiFi: WiFi Setting.
- 3) Bluetooth: The device can be connected to the Bluetooth device via this button.
- 4) Date & Time: The Date and Time can be set up via this button.
- 5) Display & Volume: The brightness of the screen and volume can be changed here.
- 6) Printer: The printer setup.

1) Ethernet

After clicking on the “Ethernet”, the following page will show up.

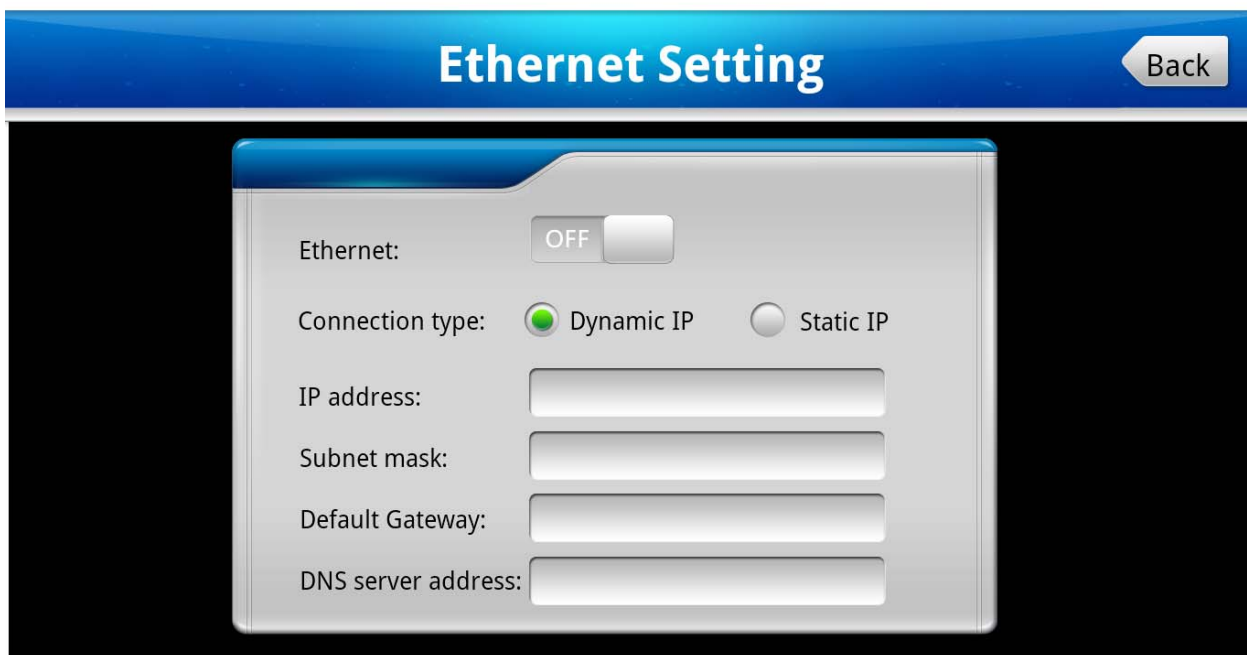

1. Switch the button on the right side of the Ethernet button to turn on/off the ethernet

2) WIFI

After clicking on the “WIFI”, the following page will show up.

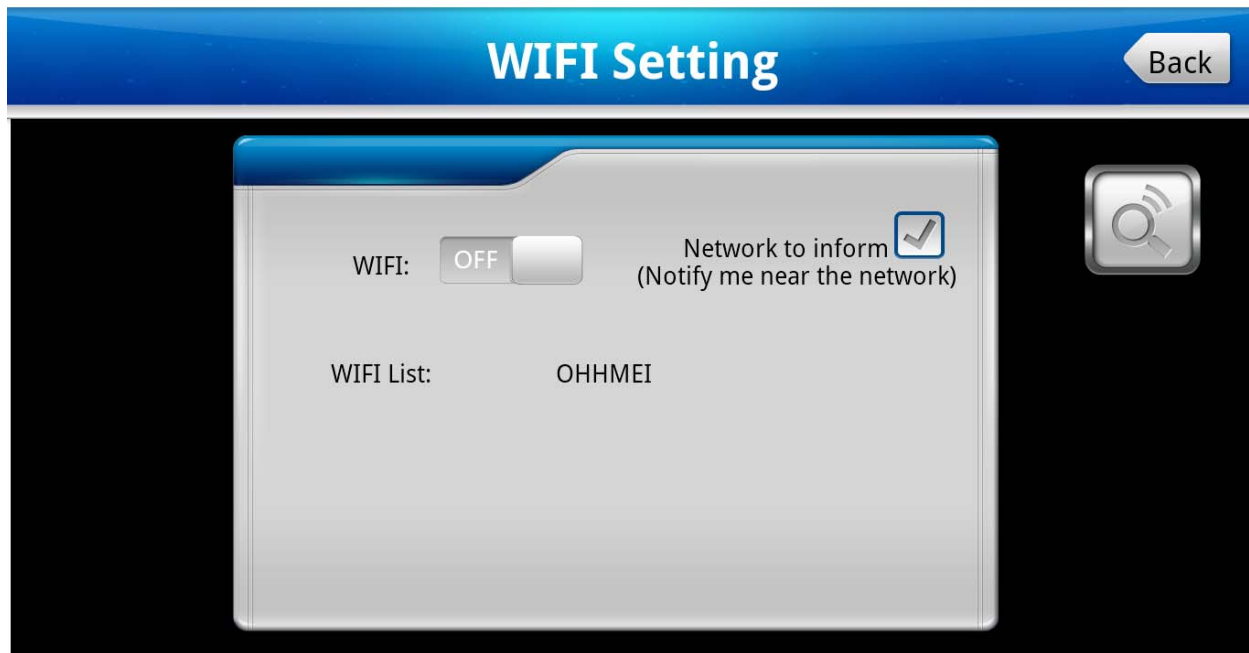

1. Switch the button on the right side of the WIFI button to turn on/off the WIFI

3) Bluetooth

After clicking on the “Bluetooth”, the following page will show up.

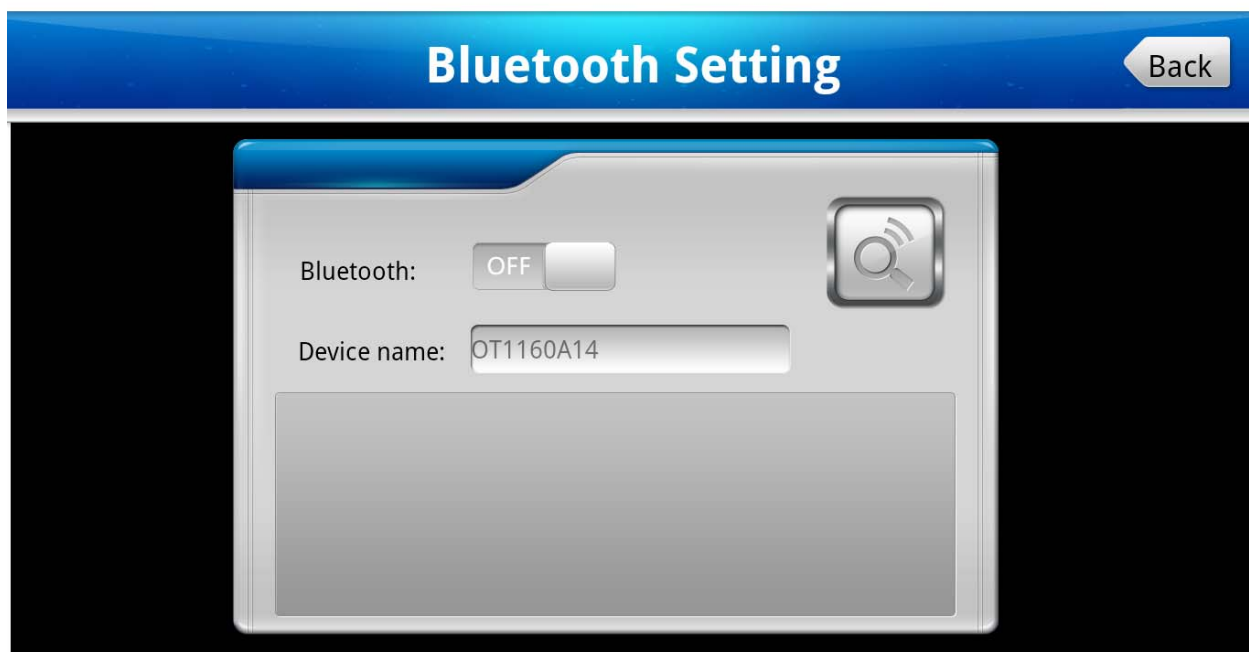

1. Switch the button on the right side of the Bluetooth button to turn on/off the Bluetooth

4) Date & Time

The Date and Time can be set up via this button. After clicking on this button, the following page will show up

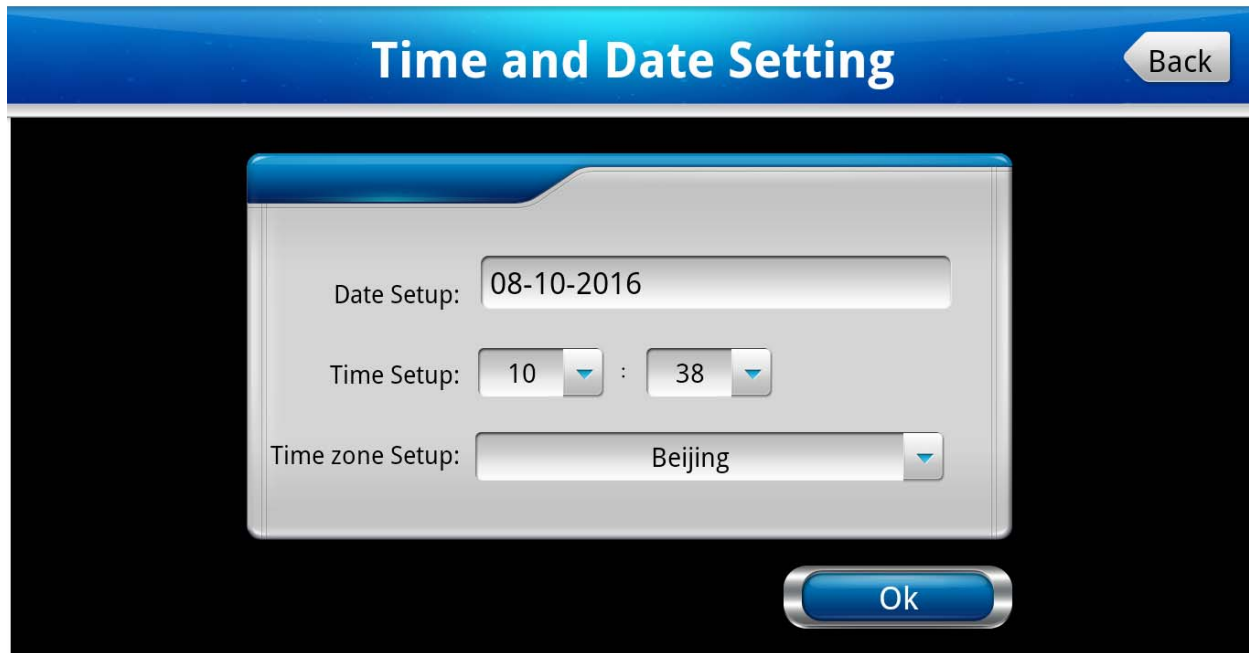

1. Date Setup. Click on the date on the right side of the date setup, a calendar will show up automatically, you can choose the date you want to set.
2. Time Setup: The time can be set up here via changing the time
3. Time zone setup: The time zone can be set up by choosing the one matching yours

5) Display & Volume:

The Display & Volume can be set up via this button. After clicking on this button, the following page will show up

6) Printer

After clicking on this button, the following page will show up

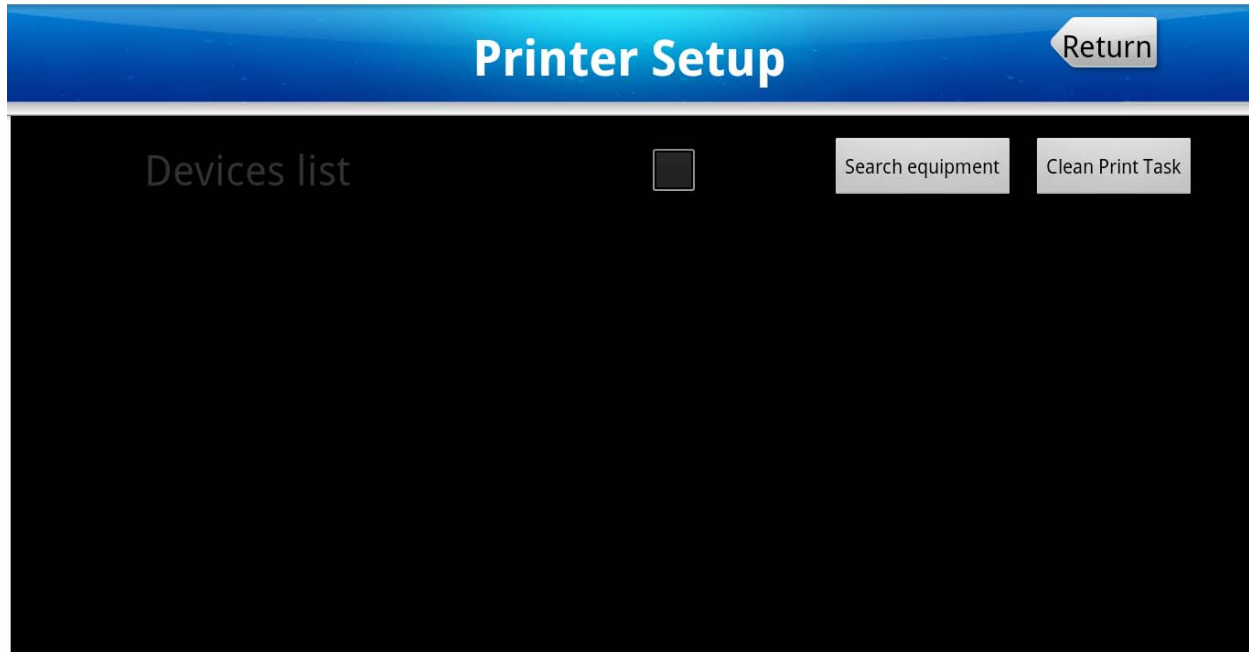

1. Clicking on “Search equipment” to search the printers within your area, and click on the one you want to connect. And then printer is set up successfully. After getting it done successfully, the patient report can be printed out via this printer.

10. Database Report:

After clicking on this button, the following page will show up

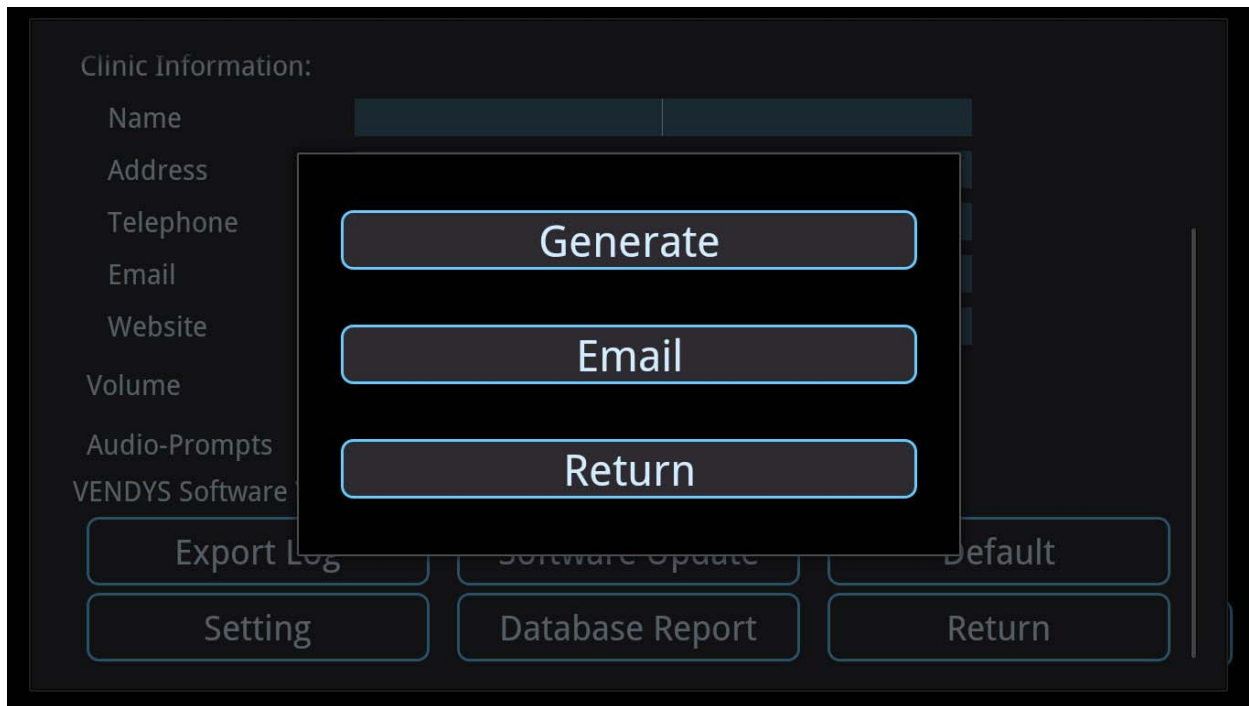

- 1) **Generate:** After clicking on the “Generate” button, all the patient test results will be compressed in one zip package. A message will appear after the compression process is done
- 2) **Email:** after clicking on “Email” button, the zip file can be sent out via email
- 3) **Return:** After clicking on this button, it will take you to the setting Main page.

2) **Email**

After clicking on “Email”, the following page will show up.

Return Send email Send

Receiver:

Cc:

Sender: vendys.endothelix@gmail.com

Subject: VENDYS Test Report

Hello, please see the VENDYS test report in the attachment.Thanks!

1. Receiver: this is the one who you want to send report to
2. CC: You can copy anyone who you want to include in this email
3. Sender: This is email address for Endothelix company
4. Subject: The default subject for this email is “VENDYS Test Report”. You can change this subject based on your need.
5. The content of the email: The default of the content is “Hello, Please see the report of your VENDYS vascular function test attached. Thank you”. You can change this subject based on your need.

Tutorial

Please find the detailed information on instruction for the login page

Contact Us

Please find the detailed information on instruction for the login page

Video Gallery

Please find the detailed information on instruction for the login page

Patient Records:

After clicking on the pale pinkish purple icon on the main page, the following page will show up.

Choose	Patient ID	Patient Name	Date of Birth	Gender
<input type="checkbox"/> +	11071303	wendy	2-1-1999	M
<input type="checkbox"/> +	11135014	mn	2-1-1999	M
<input type="checkbox"/> +	14090261	ag	1-16-1994	M

Choose	Patient ID	Patient Name	Date of Birth	Gender
<input type="checkbox"/> -	11071303	wendy	2-1-1999	M
<input type="checkbox"/>	No	Test Date/Time	Operator	
<input type="checkbox"/>	1	2016/09/11 08:31:53	Superadmin	Open Report
<input type="checkbox"/>	2	2016/09/11 09:19:27	Superadmin	Open Report
<input type="checkbox"/>	3	2016/09/11 12:26:29	Superadmin	Open Report
<input type="checkbox"/> -	11135014	mn	2-1-1999	M
<input type="checkbox"/>	No	Test Date/Time	Operator	
<input type="checkbox"/>	1	2016/09/11 13:52:35	Superadmin	Open Report

1. Saved Patient's Information: Click on the patient information to get the patient history
2. VRI Trend: This feature will show the trend for vascular function test results for a specific patient
3. Trash button: Click on the square box in front of the plus button and press on trash button, the corresponding patient record will be removed.

4. Data Quality Summary: This feature will show the summary for all the flags a specific patient suffered during the tests
5. Search: The search button will ensure you get all the information for a specific patient. You can search by Patient ID/Patient Name
6. Main page: Click here to lead you to the main page of the test.
7. Plus button: Click here to expand to get more information of the patient. Click on the row next to the square checking box, the patient information and health information will show up. The existing patient information can be edited here. Please find the screenshot below.
8. Open report: Click here to get the report for a patient on specific date

Saved Patient's Information

After clicking on one of the patient history, the following page will show up.

- 1) Save: Click here to save the changed patient information
- 2) Cancel: Click here to cancel the changes made here
- 3) Health Info: Click here to get the health information of the patient

3) Health Info

After clicking on the “Health Info”, the following page will show up.

Last Step
Patient Health Information 1/2
Next Step

Height (m) (cm)

Weight(kg)

Waist(cm)

Total Chol: (mg/dl)

HDL Chol: (mg/dl)

LDL Chol: (mg/dl)

Triglyceri: (mg/dl)

Hypertension Yes No

Diabetes Yes No

Heart Disease Yes No

Smoker Y N

Mute

Probe SN -----

Tests Available --

BP SYS/DIA (mmHg)

-- / --

Cuff Pressure -----

Pulse Rate ---

RF-Temp °C -----

LF-Temp °C -----

RM-Temp °C -----

Main Page

1. Cancel: Click here to cancel the changes made here
2. Save: Click here to save the changes made here

Open Report

After clicking on the “Open Report” button, the following page will show up.

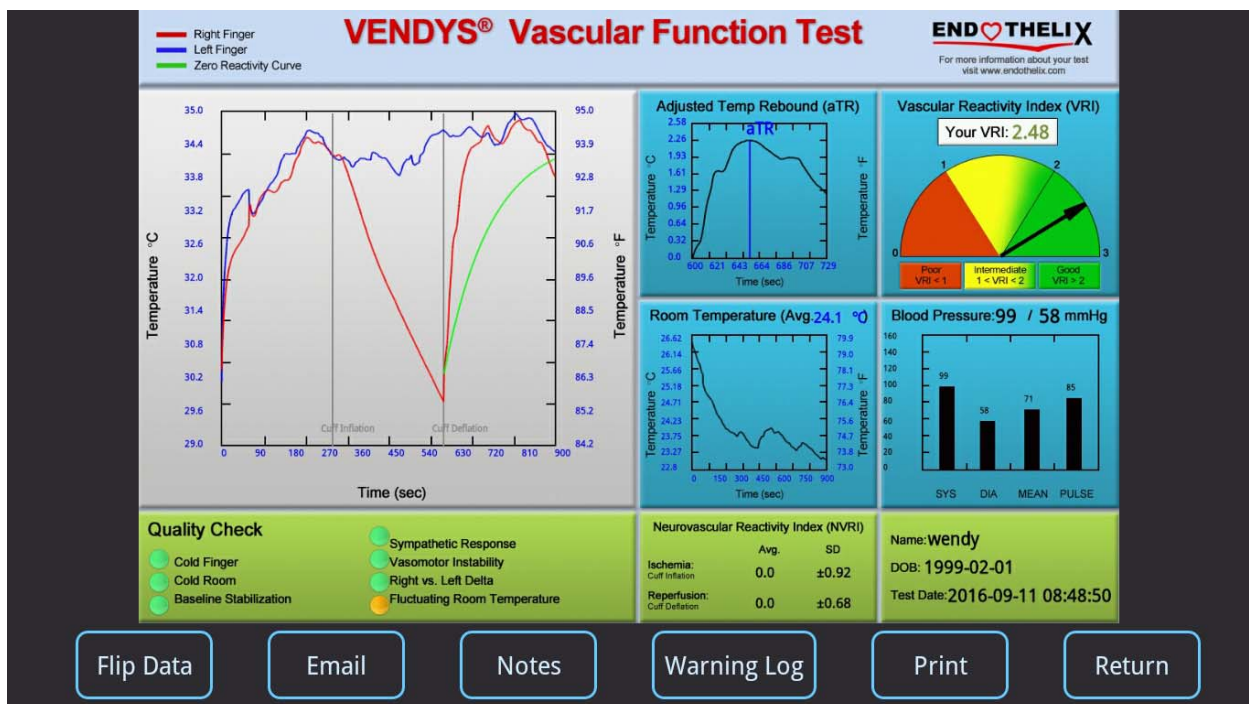

1. Flip Data: To flip the data of right and left hands, to reverse the temperature got from both hands.
2. Email: Click here to email the test report
3. Notes: Click here to add notes on this report
4. Warning log: Click here to get the warning log happened during the test
5. Print: Click here to print the test results
6. Return: Click here to return to the patient record page.

VRI Trend

After tapping on “VRI Trend”, the following page will show up

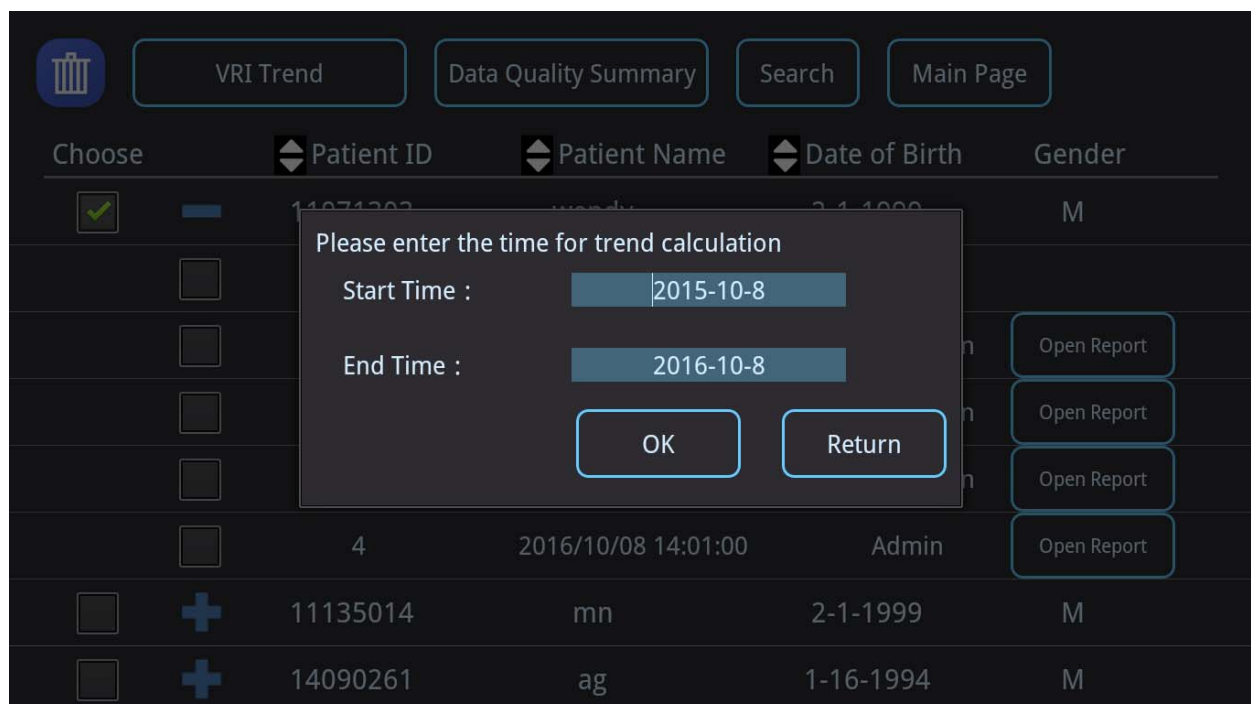

- 1) Start Time: click here to enter the searching start time.
- 2) End Time: Click here to enter the searching end time.
- 3) OK: Click here to start searching.
- 4) Return: Click here to return to the patient record page.

After clicking on “OK”, the following page will show up

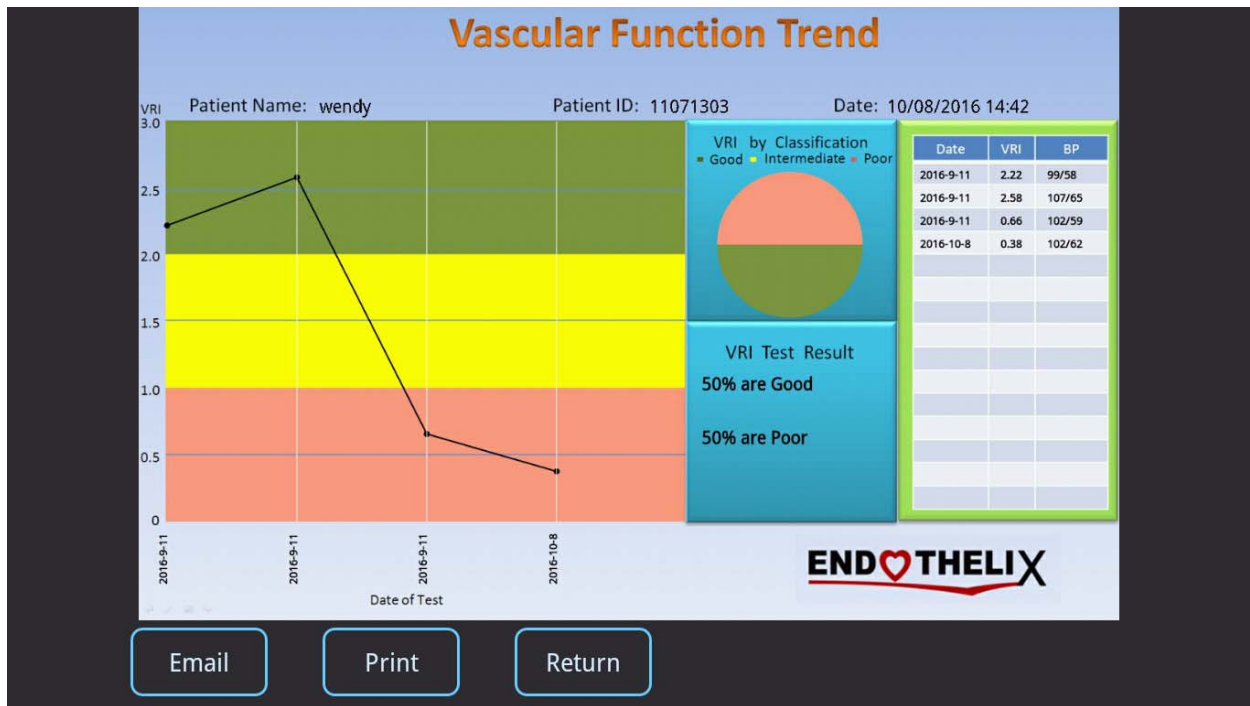

1. Email: Click here to email the VRI trend report
2. Print: Click here to print the VRI trend report
3. Return: Click here to return to the patient record page

Data Quality Summary

After clicking on the “Data Quality Summary” button, the following page will show up.

VRI Trend
Data Quality Summary
Search
Main Page

Choose	Patient ID	Patient Name	Date of Birth	Gender	
<input checked="" type="checkbox"/>	11071303	wendy	2-1-1999	M	
<input type="checkbox"/>					Open Report
<input checked="" type="checkbox"/>					Open Report
<input type="checkbox"/>					Open Report
<input type="checkbox"/>	4		2016/10/08 14:01:00	Admin	Open Report
<input type="checkbox"/>	+	11135014	mn	2-1-1999	M
<input type="checkbox"/>	+	14090261	ag	1-16-1994	M

Please enter the time for data quality summary

Start Time :

End Time :

- 1) Start Time: click here to enter the searching start time.
- 2) End Time: Click here to enter the searching end time.
- 3) OK: Click here to start searching.
- 4) Return: Click here to return to the patient record page.

After clicking on “OK”, the following page will show up

Table Summary of Tests With Flagged Conditions

Time Range 2015-10-8 ~ 2016-10-8

#OF TESTS IN TIME RANGE: 4	#(%) OF TESTS WITH FLAG
Cold Finger	0(0%)
Sympathetic Response	0(0%)
Right VS Left	0(0%)
Baseline Stabilization	0(0%)
Low Room Temperature	1(25%)
Fluctuating Room Temperature	4(100%)
Finger Room Delta	0(0%)
Data Quality Error	0(0%)

Patient Name: wendy Patient ID: 11071303



Email

Print

Return

1. Email: Click here to email the Data Quality Summary
2. Print: Click here to print the Test report Summary
3. Return: Click here to return to the patient record page

Troubleshooting

Cannot get info from Probes

1. Plug the probes back to the HDMI port on the left side of the device
2. If the problem was not get solved, please contact Endothelix support to change a new probe

Low Battery

Connect the device to the power outlet on the wall to maintain the device work very well.

Battery problem

1. Battery cannot be charged to full performance and please contact Endothelix support for thereplacement.
2. The battery cannot store the electricity and please contact Endothelix support for thereplacement.
3. The battery doesn't work after unplug the power outlet, please disconnect and connect the battery cable one more time. If the problem didn't not get solved, please contact Endothelix support for further information

Failed to get information from SD card

Take the SD card out and re-plug into the card slot.

Cannot turn on the machine

Circuit board problem and please contact Endothelix support for further information

The monitor cannot display very well after turning on the machine

LCD problem and please contact Endothelix support for further information

The screen is stuck on the booting video page

Circuit board problem and please contact Endothelix support for further information

Keypad is not coming out while typing

Circuit board problem and please contact Endothelix support for further information

VENDYS keeps rebooting after turning on

Circuit board problem and please contact Endothelix support for further information

Touch screen is not working

One of cables got loosed and please contact Endothelix support for replacement

Blood pressure cuff cannot be inflated

Circuit board problem and please contact Endothelix support for further information

Cuff leakage problem

Disconnect and reconnect the BP hose. If the problem still persists, please contact Endothelix support for replacement

Inappropriate placement of BP Cuff (other cuff problems)

Please make sure the cuff was placed on patient arm appropriately, neither too tight nor too loose.

Technical Information: Temperature Probes (RTD) Specification

Parameter	Specification
Sensor Type	1000 Ohm RTD Temperature Sensor
Sensor Curve Type	TC=3850 ppm/K
Sensor Self-Heating	0.4K/mW at 0 C
Sensor Accuracy	+/- 0.15 C minimum including cable and connector
Range	10 to 45 C(50 to 113 F)
Resolution	0.01 C (0.018 F)
Accuracy	+/- 0.1 C (0.18 F)
Host Sampling Rate	1 Hz to 40Hz in integer value increments
Wire Type	24-28 AWG twisted pairs with overall shield
Max Sensor Cable Length	6 Feet

VENDYS II Machine Specification

Parameter	Specification	Description
Min Inflated Pressure	10 mmHg	Minimum pressure to which a cuff can be inflated and held
Max Inflated Pressure	270 mmHg	Maximum pressure to which a cuff can be inflated and held
Pressure Resolution	1 mmHg	Pressure reported to host will be to nearest 1

		mmHg
Pressure Accuracy	+/- 5 mmHg	Absolute accuracy of pressure measurement
Pulse Rate Range	40 - 240 BPM	
Pulse Rate Resolution	1BMP	
Cuff Regulation	+/- 10 mmHg	Cuff pressure will be maintained to specified pressure with this tolerance
Min Pumping Rate	6 LPM	Minimum rate of pumping air into cuff at no load
Power Input Voltage	24 V.D.C.+/- 5%	Regulated 24 VDC power supply voltage
Max Power Input Voltage Ripple	100mv pk-pk	
Max Occlusion Duration	20 minutes	The maximum duration that either of the cuffs can be inflated
Battery voltage	D.C. 14.8V	The built-in battery lithium battery

Product Labels

Packing List for VENDYS System



NO.	Name	Number	Productchart	Functiondescription	Note
1	VENDYS-II Machine	1PCS		Measures and displays vascular function using digital thermal monitoring of	Importantaccessories
2	Temperature Probes and	1PCS		Fingertip and room temperature sensors	Importantaccessories
3	Adhesive Clips	1PCS		Attaches to fingertips for accurate	Importantaccessorie
4	Cuff Tube	1PCS		ConnectsBPcufftoVENDYS-II Machine	Importantaccessories
5	Blood Pressure Cuff	1PCS		Measuresbloodpressure	Importantaccessories
6	Infrared Thermomet	1PCS		Instant measure of fingertip temperature to detect cold fingers	Importantaccessories
7	Laptop hands pad	1PCS		Rests hands and isolates fingertip temperature	Importantaccessories
8	Electric Heating Blanket	1PCS		To warm subjects and alleviate cold fingers	Importantaccessories
9	PowerAdapter	1PCS		Powersupplyfor VENDYS-II machine	Importantaccessories
10	PowerCord	1PCS		Connects powersupplytothemachine	Importantaccessories
11	Instruction Manual	1PCS		Detailed instructions to operate VENDYS-II System	Importantaccessories
12	Quick Guide	1PCS		Quick illustrative guide to operate VENDYS-II System	Importantaccessories
13	Certificate	1PCS		Quality controlcertificates	Importantaccessories
14	WarrantyCard	1PCS		Productwarrantycertificate	Importantaccessories
15	PackingList	1PCS		Packinglist	Importantaccessories

Appendix A: License Agreement and Limited Warranty

User Hardware/Software/Product License from Endothelix

IMPORTANT – PLEASE READ THIS LICENSE AGREEMENT CAREFULLY BEFORE INSTALLING OR OTHERWISE USING THE LICENSED HARDWARE AND SOFTWARE (AS DEFINED BELOW) OR THE PRODUCT WITH WHICH YOU RECEIVED THIS LICENSE AGREEMENT. THIS LICENSE AGREEMENT APPLIES TO:

- a) ALL LICENSED HARDWARE AND ITS USE AS PROGRAMMED BY ENDOTHELIX ONLY AND MEDICAL AND PHYSICAL DATA ACCUMULATED FROM COMBINED HARDWARE, SOFTWARE AND PRODUCT USE UNDER THE PRODUCT AS PROVIDED;**
- b) ALL LICENSED SOFTWARE AND ITS USE AS PROGRAMMED BY ENDOTHELIX ONLY AND MEDICAL AND PHYSICAL DATA ACCUMULATED FROM COMBINED HARDWARE, SOFTWARE AND PRODUCT USE UNDER THE PRODUCT AS PROVIDED;**
- c) ALL LICENSED PRODUCTS (AS DEFINED BELOW), and**
- d) ALL THIRD PARTY PRODUCTS (AS DEFINED BELOW).**

SHOULD YOU HAVE ANY QUESTIONS CONCERNING THIS LICENSE AGREEMENT, OR PERMITTED USE OF THE HARDWARE, SOFTWARE, OR PRODUCT(S) PROVIDED THROUGH THIS AGREEMENT, PLEASE CONTACT THE VENDOR FROM WHICH YOU PURCHASED THE LICENSED HARDWARE, LICENSED SOFTWARE, LICENSED PRODUCT OR THIRD PARTY PRODUCT. YOU MAY ALSO CONTACT ENDOTHELIX AT THE ADDRESS PROVIDED AT THE END OF THIS LICENSE AGREEMENT.

This License Agreement is a legal instrument between you (as an individual, company, organization, or other entity) and Endothelix Inc. (“Endothelix”). By installing, copying, or otherwise using this Licensed Product, Licensed Hardware or Licensed Software or any Third Party Product, you agree to be bound by the terms of this License Agreement with respect to the Licensed Hardware, Licensed Software and Licensed Products. If you do not agree to the terms of this License Agreement, INCLUDING, WITHOUT LIMITATION, THE LIMITATIONS ON USE AS PROVIDED IN SECTION 2.4 AND THE RESTRICTIONS ON USE AS PROVIDED IN SECTION 2.5, do not install, use or copy the Licensed Hardware, Licensed Software or Licensed Product or the Third Party Product.

For avoidance of doubt, in the event that you have entered into an agreement in writing (“Subsequent Agreement”) with Endothelix covering the subject matter of this License, then to the extent any such terms or provisions of such Subsequent Agreement are in conflict with, different than, or in addition to, the terms and provisions of this license, such terms and provisions of such Subsequent Agreement shall prevail.

The Licensed Software and the Licensed Products are protected by US patent laws, trade secret laws, copyright laws, and international treaty provisions as well as other intellectual property laws and treaties. Therefore, you must treat the Licensed Hardware, Licensed Software and Licensed Products like any other copyrighted and protected material or product. Therefore, you must treat the Licensed Hardware, Licensed Software and all intellectual property rights in and to the Licensed Hardware or Licensed Software and the Licensed Products shall remain with Endothelix.

1. Definitions

1.1 “Licensed Product(s) “ means the *VENDYS*[®], the test probes (whether provided with the

product directly by sale, resale, lease, or other placement method, directly or indirectly), and the corresponding component of Endothelix or any Third Party Product with which this Licensed Agreement was received. The Licensed Product(s) is (are) a stand-alone product and some Third Party Products are incorporated for component use in the Licensed Products, as such may be in each case sold, leased, or otherwise made available by Endothelix and/or third parties. If you have received this License Agreement with a Third Party Product, this License Agreement applies only to the Licensed Product incorporated use as a component within the Licensed Product or a Third Party Product.

1.2 “Licensed Software” means the EndothelixVENDYS®_software, and the associated media and accompanying materials provided to you with such *EndothelixVENDYS®*software. The Licensed Software is a stand-alone software program used only with the Licensed Hardware and Licensed Product to provide resulting data information from the overall combined use and operation of the Licensed Software, Licensed Hardware, and Licensed Product, as in each case sold, leased or otherwise made available, by Endothelix and/or third parties. If you have received this License Agreement with a Licensed Product, which incorporates the software as a component within such Licensed Product, this License Agreement applies to the Licensed Software.

1.3 “Licensed Hardware” means the EndothelixVENDYS®software, and the associated media and accompanying materials provided to you with such *EndothelixVENDYS®*software. The Licensed Software is a stand-alone software program used only with the Licensed Hardware to provide resulting data information from the overall combined use and operation of the Licensed Software, Licensed Hardware, and Licensed Product, as in each case sold, leased or otherwise made available, by Endothelix and/or third parties. If you have received this License Agreement with a Licensed Product, which incorporates the software as a component within such Licensed Product, this License Agreement applies to the Licensed Software.

1.4 “Third Party Product” means any product which a Licensed Product or into which any of the Licensed Product, Licensed Software, or Licensed Hardware is incorporated.

2. LICENSE TO USE, LIMITATIONS AND RESTRICTIONS ON USE

2.1 LICENSE TO USE LICENSED SOFTWARE. Endothelix hereby grants you a non-exclusive right to use the Licensed Software (i) solely with the Licensed Product(s), and (ii) solely for its intended use in testing of endothelial function in accordance with the provisions of this License Agreement and the instructions provided in the documentation accompanying the Licensed Hardware, Licensed Software and the Licensed Product, subject to the Limitations on Use as provided in Section 2.5. You may only download the data provided for download by the hardware and software program functions as provided by Endothelix for pre-programmed use of the Licensed Product(s). However, you may not cause any Licensed Software, which is not designed or specifically authorized by Endothelix for use as part of the Product, to execute or be loaded into the active memory or media of any other computer apart from the computer programmed system provided on the Licensed Product only.

2.2 LICENSE TO USE LICENSED HARDWARE. Endothelix hereby grants you a non-exclusive right to use the Licensed Hardware (i) solely with the Licensed Product(s), and (ii) solely for its intended use in testing of endothelial function in accordance with the provisions of this License Agreement and the instructions provided in the documentation accompanying the Licensed Hardware, Licensed Software and the Licensed Product, subject to the Limitations on Use as provided in Section 2.5. You may not make any copy of the Licensed Hardware for any purpose, and you may not transfer the Licensed Hardware to any single hard disk for any purposes.

2.3. LICENSE TO USE LICENSED PRODUCTS. Endothelix hereby grants you a non-

exclusive right to use the Licensed product(s) (i) solely with the Licensed Software and Licensed Hardware provided as component parts of the Licensed Product, and (ii) solely for its intended use in testing endothelial function in accordance with the provisions of this License Agreement and the instructions provided in the documentation accompanying the Licensed Software, Licensed Hardware and Licensed Product, subject to the limitations on Use in Section 2.3 and the Restrictions on Use as provided in Section 2.5.

2.4. LIMITATIONS ON USE. The licenses granted in Sections 2.1, 2.2 and 2.3 above are for use in normal medical practice, and you are not licensed or authorized to include, or use in any manner, or to provide to any third party for such inclusion or use, any test results derived from the *VENDYS*® and/or the Licensed Software and/or Licensed Hardware for the purpose of obtaining any regulatory approval from any governmental or regulatory agency of any diagnostic or therapeutic claim, or medical device, pharmaceutical or other therapeutic or diagnostic product. Without derogating from the generality of the foregoing, the inclusion by you of any third party of any results of any type, derived through the use of the *VENDYS*® and/or the accompanying Licensed Software and Licensed Hardware, in any regulatory filing for the purpose of supporting, or obtaining such approval, without the prior written consent of Endothelix is expressly prohibited. THIS LIMITATION REFERES SOLELY TO THE SEEKING OR OBTAINING OF DIAGNOSTIC OR THERAPEUTIC CLAIMS AND NOTHING IN THIS AGREEMENT, INCLUDING THS LIMITATION ON USE, IS INTENDED, IN ANY MANNER, TO RESTRICT THE REPORTING OF INFORMATION REGARDING THE *VENDYS*® IN ACCORDANCE THE REPORTING REGULATIONS OF ANY GOVERNMENTAL OR REGULATORY AGENCY.

Notwithstanding the foregoing limitations on use, you are granted permission to use the data and compilations obtained from your use of the Licensed Product for the following limited purposes, under the further strict limitation in such use, of your compliance with all patient privacy rights as provided under governmental law or regulation for patient privacy and for use and compilation of medical information and research group data from individual patient applications and data collection, including:

- a) You are permitted to use data information compiled and provided you under the programmed use of in the Licensed Product for educational, scientific, or research purposes, including data compiled and extracted from use of the Licensed Product, for the purpose of illustration, explanation, example, comment, criticism, teaching, research, or analysis;
- b) You are permitted to use data information compiled and provided you under the programmed use of in the Licensed Product in the preparation of Course Packs or other educational materials;
- c) You are permitted to use data information compiled and provided you under the programmed use of in the Licensed Product for use in connection with specific courses of instruction offered by you for medical education purposes; and
- d) You may transmit to a third party in hard copy or electronically, minimal, insubstantial amounts of collected data compiled and provided you under the programmed use of in the Licensed Product for scholarly, educational, or scientific research or professional use, but in no case for resale or commercial purposes.

2.5. RESTRICTIONS ON USE. Any use of the Licensed Software, Licensed Hardware and/or Licensed Product other than as set forth in Sections 2.1, 2.2, and 2.3 above, in each case as limited by Section 2.4 above, is strictly forbidden. Without derogating from the generality of the above you may not:

- a) distribute, reproduce, copy, assign, rent, lease, or otherwise transfer the rights granted to you under this License Agreement to any third party except as explicitly set forth in this License Agreement;
- b) reverse engineer, decompile, or disassemble, as applicable the Licensed Software, Licensed

Hardware, or Licensed Product, except as expressly permitted by applicable law; or

c) modify in any manner the Licensed Software and/or the Licensed Product unless obtaining the prior written consent of Endothelix.

3. TRADEMARKS

Endothelix, VENDYS® and all trademarks and logos, which appear on or in connection with the Licensed Software, Licensed Hardware and/or Licensed Products, as may be amended from time to time, are, unless stated otherwise, trademarks of Endothelix. No right, license, or interest to such trademarks are generated or granted hereunder other than the limited right to use provided herein, and you agree that no such right, license, or interest shall be asserted by you with respect to such trademarks. You may not remove or destroy any copyright, logo or other proprietary marking or legend placed on or contained in the Licensed Software, Licensed Hardware or a Licensed Product.

4. LIMITED WARRANTIES AND DISCLAIMERS

4.1. AGAINST INFRINGEMENT. Endothelix hereby warrants to you that it has the right to grant you the license to use the Licensed Software, Licensed Hardware and/or Licensed Product and to enter into this License Agreement and that neither the Licensed Software, the Licensed Hardware nor the Licensed Product(s) infringes the intellectual property rights of any third party.

4.2. AS TO LICENSED PRODUCT. Endothelix warrants to you that the Licensed Product, with which this Licensed Agreement was delivered, will be free from defects in design, materials, and workmanship for a period of one year from the date of delivery of the Licensed Product to you. If the Licensed product contains a defect in design, materials or workmanship and such Licensed Product is returned to Endothelix within one (1) year of delivery of the Licensed Product to you, Endothelix will repair or replace the Licensed product, or issue a credit for the purchase price of the Licensed product, with the choice to repair, replace, or credit being within the sole discretion of Endothelix. The foregoing repair, replacement, or credit remedy will be your sole remedy for breach of the warranty set forth in this Section 4.2.

4.3. AS TO LICENSED SOFTWARE. Endothelix warrants that for a period of ninety (90) days from the date of delivery of the Licensed Software to you, the Licensed Software will, under normal use, be free from defects in materials and workmanship, and will perform substantially as it is intended to perform. If during such ninety (90) days, the Licensed Software has a defect in materials or workmanship or does not perform substantially as it is intended to perform, Endothelix will (a) attempt to correct or assist you around errors with efforts which Endothelix believes suitable to the problem, (b) replace the Licensed Software with a functionally equivalent software, or (c) issue a credit for the purchase price of the Licensed Software, with the choice to correct or assist, replacement or credit being within the sole discretion of Endothelix. The foregoing correct or assist, replacement or credit remedy will be your sole remedy for breach of the warranty set forth in this Section 4.3.

4.4. AS TO LICENSED HARDWARE. Endothelix warrants that for a period of ninety (90) days from the date of delivery of the Licensed Hardware to you, the Licensed Hardware will, under normal use, be free from defects in materials and workmanship, and will perform substantially as it is intended to perform. If during such ninety (90) days, the Licensed Hardware has a defect in materials or workmanship or does not perform substantially as it is intended to perform, Endothelix will (a) attempt to correct or assist you around errors with efforts which Endothelix believes suitable to the problem, (b) replace the Licensed Hardware with a functionally equivalent software, or (c) issue a credit for the purchase price of the Licensed Hardware, with the choice to correct or assist, replacement or credit being within the sole discretion of Endothelix. The foregoing correct or assist, replacement or credit remedy will be your sole remedy for breach of the warranty set forth in this Section 4.4.

4.5. LIMITATION OF WARRANTIES. The warranties contained in Sections 4.2, 4.3, and 4.4 above do not cover damage to the Licensed Products, Licensed Software or Licensed Hardware caused by accident, misuse, abuse, negligence, failure to install in accordance with Endothelix's installation instructions, failure to operate under conditions of normal use and in accordance with the terms of the documentation accompanying the Licensed Product, Licensed Software, and/or Licensed Hardware, failure to maintain in accordance with the applicable documentation accompanying the Licensed Product, Licensed Software, and/or Licensed Hardware, alteration or any defects not related to materials or workmanship, or in the case of Third Party Licensed Products, design, materials or workmanship. This warranty does not cover damage which may occur in shipment. This warranty does not apply to Licensed Products, Licensed Software, or Licensed Hardware not purchased new. This warranty does not apply to any Licensed Product or any individual parts of a Licensed product which have been repaired or altered by anyone other than Endothelix or a person or entity authorized by Endothelix to repair Licensed products.

While every reasonable effort has been made to ensure that you will receive Licensed Software, Licensed Hardware, and/or Licensed Product that you can use, Endothelix does not warrant that the function of the Licensed Product, Licensed Software, and/or Licensed Hardware will meet your requirements or that the operation of the Licensed Product, Licensed Software, and/or Licensed Hardware will be uninterrupted or error free. Endothelix is not responsible for problems caused by your use of the Licensed Software with non-Endothelix software or non-Endothelix hardware.

ENDOTHELIX HEREBY DISCLAIMS, WITH RESPECT TO THE LICENSED SOFTWARE, LICENSED HARDWARE AND THE LICENSED PRODUCTS, ALL OTHER WARRANTIES AND CONDITIONS, WHETHER EXPRESS OR IMPLIED, INCLUDING, BUT NOT LIMITED TO MERCHANTABILITY, FITNESS FOR A PARTICULAR PURPOSE, ACCURACY OR COMPLETENESS OF INFORMATION, LACK OF NEGLIGENCE AND CORRESPONDENCE TO DESCRIPTION.

5. LIMITATION OF LIABILITY

(A) TO THE MAXIMUM EXTENT PERMITTED BY APPLICABLE LAW, EXCEPT FOR DAMAGES ARISING UNDER SECTION 4.1 ABOVE, IN NO EVENT SHALL ENDOTHELIX BE LIABLE TO YOU FOR DAMAGES IN EXCESS OF THE PURCHASE PRICE YOU PAID FOR THE LICENSED PRODUCT, LICENSED SOFTWARE, AND/OR LICENSED HARDWARE, OR THE APPLICABLE THIRD PARTY PRODUCT. THE FOREGOING LIMITATION SHALL BE APPLICABLE REGARDLESS OF WHETHER THE ACTION GIVING RISE TO SUCH DAMAGES IS I TORT, CONTRACT, STRICT PRODUCTS LIABILITY, OR OTHERWISE.

(B) IN NO EVENT SHALL ENDOTHELIX BE LIABLE FOR ANY SPECIAL, INCIDENTAL, INDIRECT OR CONSEQUENTIAL DAMAGES WHATSOEVER ARISING OUT OF OR IN ANY WAY RELATED TO THE USE OF OR INABILITY TO USE THE LICENSED SOFTWARE, LICENSED HARDWARE, LICENSED PRODUCT, OR THIRD PARTY PRODUCT, OR THE PROVISION OR FAILURE TO PROVIDE SUPPORT SERVICES BY ENDOTHELIX, EVEN IF ENDOTHELIX HAS BEEN ADVISED OF THE POSSIBILITY OF SUCH CONSEQUENTIAL DAMAGES. THE FOREGOING DISCLAIMER OF CONSEQUENTIAL DAMAGES SHALL BE APPLICABLE REGARDLESS OF WHETHER THE ACTION GIVING RISE TO SUCH DAMAGES IS IN TORT, CONTRACT, STRICT PRODUCT LIABILITY, OR OTHERWISE.

(C) IN ORDER TO BE ENTITLED TO INDEMNIFICATION HEREUNDER IN CONNECTION WITH AN INFRINGEMENT CLAIM, YOU MUST (i) NOTIFY ENDOTHELIX IN WRITING PROMPTLY UPON BECOMING AWARE OF AN

INFRINGEMENT CLAIM OR THE POSSIBILITY THEREOF, (ii) GRANT ENDOTHELIX SOLE CONTROL OF THE SETTLEMENT, COMPROMISE, NEGOTIATION AND DEFENSE OF ANY SUCH ACTION, AND (iii) PROVIDE ENDOTHELIX WITH ALL INFORMATION RELATED TO THE ACTION THAT IS REASONABLY REQUESTED BY ENDOTHELIX. NOTWITHSTANDING THE FOREGOING, ENDOTHELIX SHALL HAVE NO INDEMNIFICATION OBLIGATIONS WITH RESPECT TO ANY INFRINGEMENT CLAIM TO THE EXTENT ARISING FROM YOUR USE OF THE LICENSED SOFTWARE, LICENSED HARDWARE, LICENSED PRODUCT OR LICENSED THIRD PARTY PRODUCT WHERE USE WITH SUCH OTHER HARDWARE OR SOFTWARE GAVE RISE TO THE INFRINGEMENT CLAIM.

6. TERMINATION

Without prejudice to any other rights or remedies, Endothelix may terminate this License Agreement immediately if you fail to comply with any of its terms and conditions. In the event of such termination, you must, within ten (10) business days of receiving notice of termination from Endothelix, cease all use of the Licensed Software and Licensed Hardware and destroy all copies thereof, and cease all use of the Licensed Product (including Licensed Product incorporated within Third Party Product).

7. TRANSFERABILITY

You may only transfer or assign the rights and obligations hereunder with the Licensed Software, Licensed Hardware and/or the Licensed Product or Third Party Product as a whole, without retaining any rights or, subject to Sections 2 and 3 above, any obligations arising after the date of such transfer or assignment, or retaining any installed or uninstalled copy of the Licensed hardware, Licensed Software, the Product or the Third Party Product. Any attempt by you to rent, lease, sublicense, assign or transfer any of the rights, duties or obligations hereunder in any other way is forbidden and shall be null and void.

8. SEVERABILITY

Should any term or provision of this License Agreement be declared void or unenforceable by any court of competent jurisdiction in any country or countries, such declaration shall have no effect on the remainder of this License Agreement in such country or countries, or on this License Agreement in other countries.

9. NO WAIVER

The failure of either party to enforce any rights granted to it hereunder or to take action against the other party in the event of any breach hereunder shall not be deemed a waiver by that party as to subsequent enforcement actions in the event of future breaches.

10. GOVERNING LAW AND JURISDICTION

This License Agreement is governed by the laws of the State of Texas, excluding its conflict of laws principles. The United Nations Convention on Contracts for the International Sale of Goods shall not apply to any of the transactions contemplated by this License Agreement.

11. ENTIRE UNDERSTANDING

This License Agreement represents the complete and exclusive understanding between you and Endothelix concerning the license by Endothelix to you of Licensed Software, Licensed Hardware, and Licensed Products and supersedes all prior agreements and representations between the parties with respect to the subject matter hereof, unless specifically stated otherwise in a writing signed by Endothelix and you. The License Agreement may not be amended other than by a written agreement specifically intended for this purpose and signed by Endothelix and you.

FCC Statement

This device complies with part 15 of the FCC Rules. Operation is subject to the following two conditions: (1) This device may not cause harmful interference, and (2) this device must accept any interference received, including interference that may cause undesired operation.

Any Changes or modifications not expressly approved by the party responsible for compliance could void the user's authority to operate the equipment.

Note: This equipment has been tested and found to comply with the limits for a Class B digital device, pursuant to part 15 of the FCC Rules. These limits are designed to provide reasonable protection against harmful interference in a residential installation. This equipment generates uses and can radiate radio frequency energy and, if not installed and used in accordance with the instructions, may cause harmful interference to radio communications. However, there is no guarantee that interference will not occur in a particular installation. If this equipment does cause harmful interference to radio or television reception, which can be determined by turning the equipment off and on, the user is encouraged to try to correct the interference by one or more of the following measures:

- Reorient or relocate the receiving antenna.
- Increase the separation between the equipment and receiver.
- Connect the equipment into an outlet on a circuit different from that to which the receiver is connected.
- Consult the dealer or an experienced radio/TV technician for help.

FCC RF Exposure Information and Statement

The devices has been tested and meets applicable limits for Radio Frequency (RF) exposure.

When carrying the product or using it a distance of 20 cm from the body to ensure compliance with RF exposure requirements. Use of other accessories may not ensure compliance with FCC RF exposure guidelines.

Contact Address: Should you have any questions concerning this License Agreement, or if you desire to contact Endothelix for any reason, please write to:

Endothelix Inc.

710 N Post Oak Rd, Ste 204

Houston, Texas 70024