

## Bendix® AD-IS® Air Dryer and Reservoir System

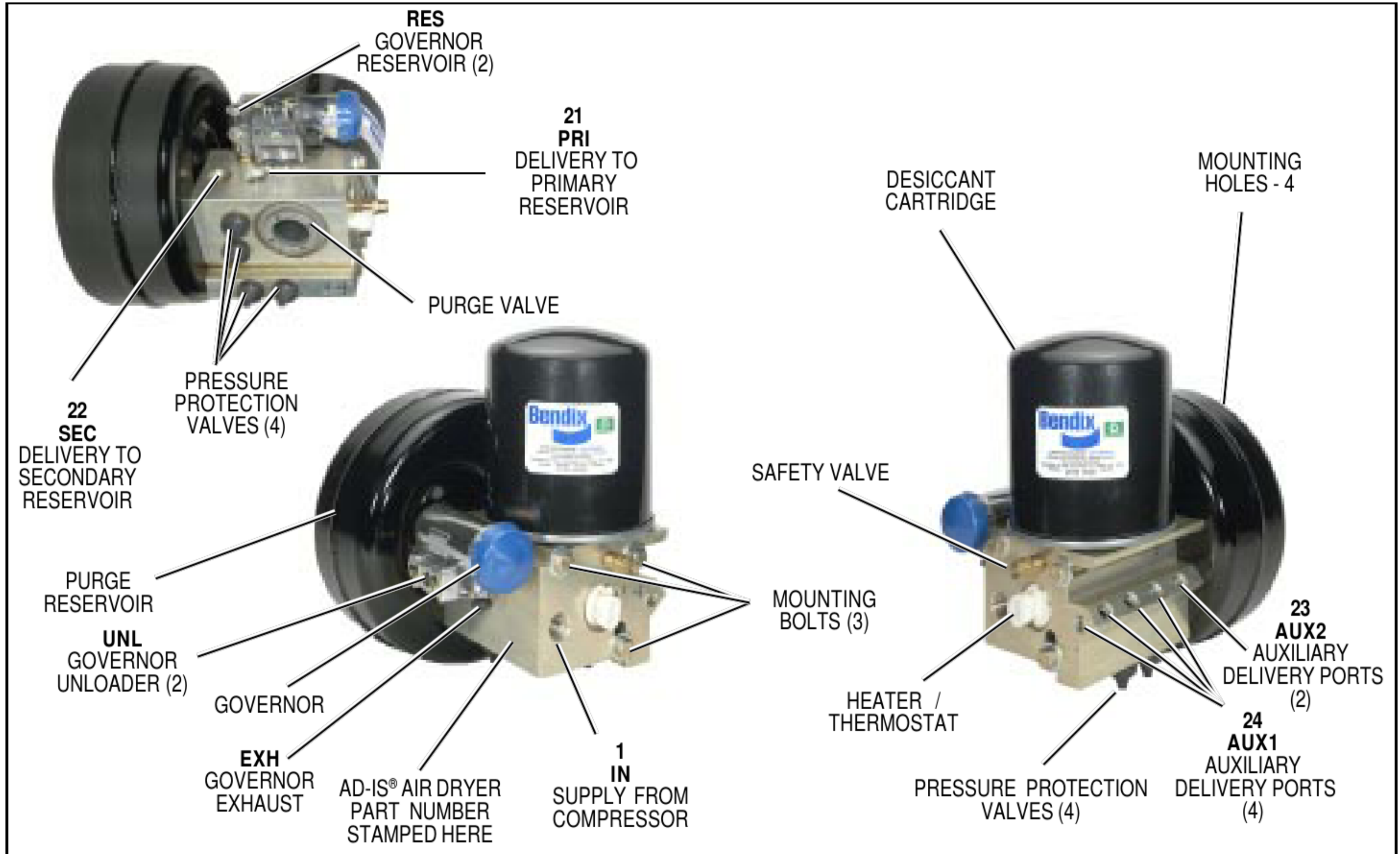

FIGURE 1 - AD-IS® AIR DRYER AND RESERVOIR SYSTEM

### DESCRIPTION

The function of the **Integrated Solution Air Dryer (AD-IS®)** and Reservoir System is to provide heavy vehicles with an integrated vehicle air dryer, purge reservoir, governor and a number of the charging valve components in a module. These have been designed as an integrated air supply system.

The AD-IS® air dryer and reservoir system collects and removes air system contaminants in solid, liquid and vapor form before they enter the brake system. It provides clean, dry air to the components of the brake system which increases the life of the system and reduces maintenance costs. The necessity for daily manual draining of the reservoirs is eliminated.

Air Connection Port ID	Function/Connection	QTY
1 IN	Inlet Port (air in).	1
21 PRI	Delivery Port out (to Primary reservoir)	1
22 SEC	Delivery Port out (to Secondary reservoir)	1
24 AUX 1	Auxiliary Delivery Port (air out).	4
23 AUX 2	Auxiliary Delivery Port (air out).	1
UNL RES	Unloader Control Air (D-2A™ Governor) Common Reservoir Pressure (D-2A™ Governor)	2 2
EXH	Governor Exhaust	1

TABLE 1 - PORT DESIGNATIONS

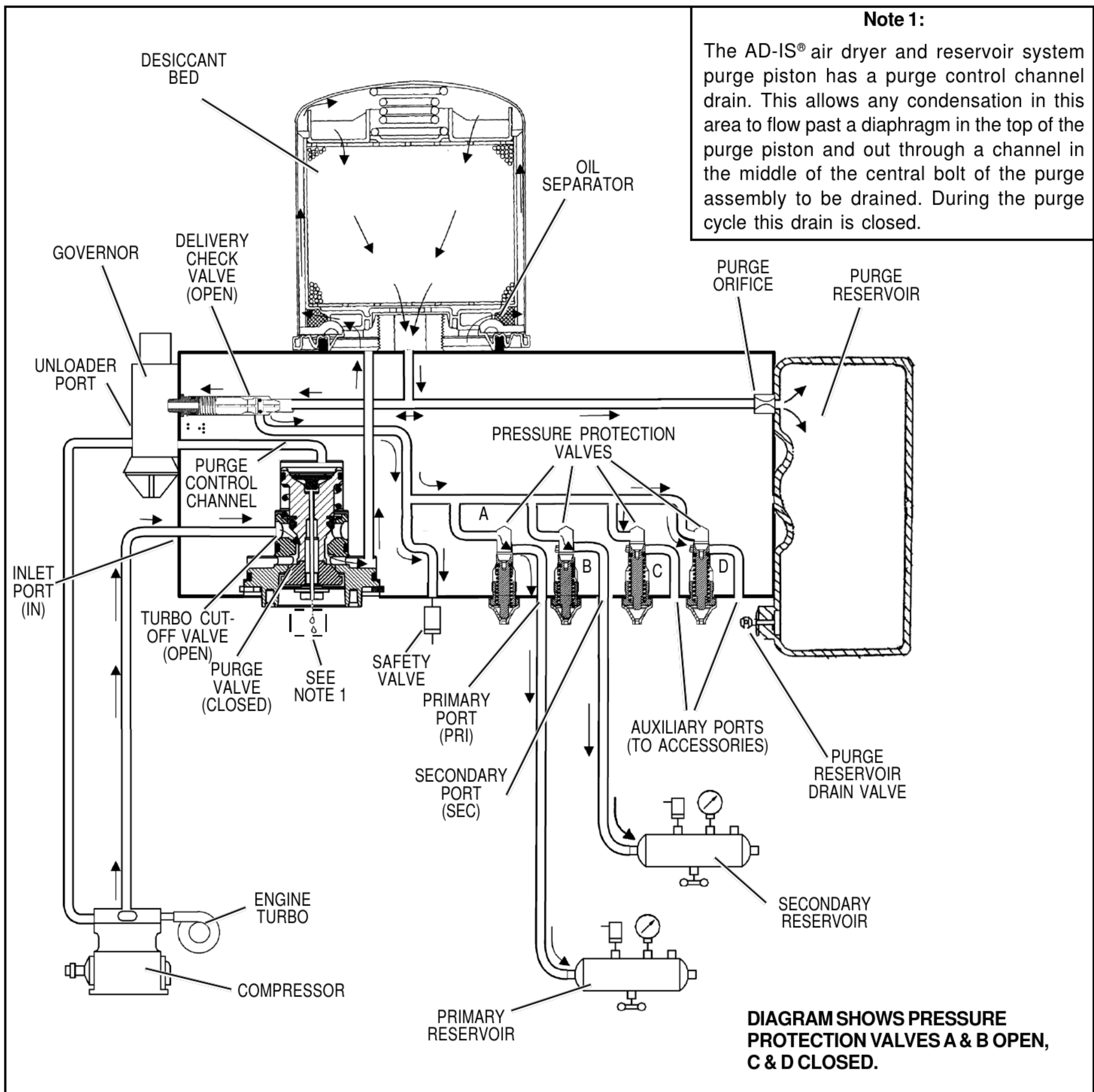

FIGURE 2 - AD-IS® AIR DRYER AND RESERVOIR SYSTEM CHARGE CYCLE

The function of the pressure protection valves is to protect each reservoir from a pressure loss in the other reservoir or a pressure loss in an air accessory. Each of the pressure protection valves in the AD-IS® air dryer and reservoir system may have different pressure settings, but these are factory set and must not be changed or adjusted.

The air dryer and reservoir system consists of a “spin on” desiccant cartridge secured to a base assembly. The base assembly contains a delivery check valve assembly, safety valve, heater and thermostat assembly, pressure protection valves, threaded air connections and the purge valve assembly.

The removable purge valve assembly incorporates the purge valve mechanism and a turbocharger cut-off feature that is designed to prevent loss of engine “turbo” boost pressure during the purge cycle of the AD-IS® air dryer and reservoir system. For ease of maintenance, all replaceable assemblies can be serviced without removal of the air dryer and reservoir system from its mounting on the vehicle. Refer to *Preventive Maintenance* section.

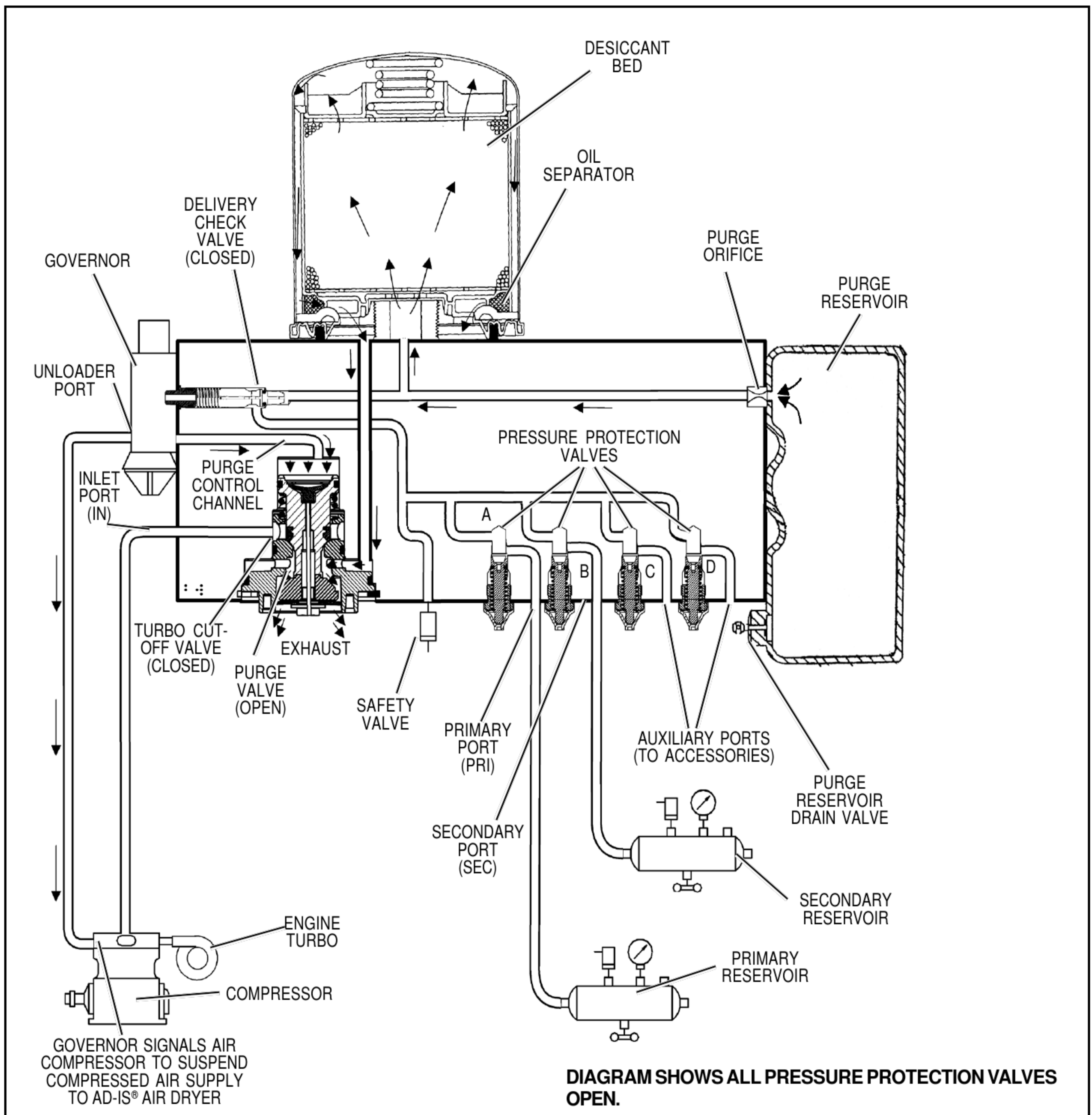

FIGURE 3 - AD-IS® AIR DRYER AND RESERVOIR SYSTEM PURGE CYCLE

**AD-IS® AIR DRYER AND RESERVOIR SYSTEM OPERATION: GENERAL (Refer to Figure 2)**

The AD-IS® air dryer and reservoir system is designed to receive compressed air from the vehicle air compressor, clean and dry the air, deliver air to the vehicle's primary reservoir, secondary reservoir and accessories, and control the compressor/dryer charge cycle.

**AIR DRYER AND RESERVOIR SYSTEM OPERATION: GENERAL**

The AD-IS® air dryer and reservoir system alternates between two operational modes or "cycles" during operation: the

*Charge Cycle* and the *Purge Cycle*. The following descriptions are separated into these "cycles" of operation.

**CHARGE CYCLE (Refer to Figure 2)**

When the compressor is loaded (compressing air) compressed air flows through the compressor discharge line to the inlet (1/IN) port of the air dryer body. The compressed air often includes contaminants such as oil, oil vapor, water and water vapor.

Traveling through the discharge line and into the air dryer, the temperature of the compressed air falls, causing some

of the contaminants to condense and drop to the bottom of the air dryer and reservoir system purge valve assembly, ready to be expelled at the next purge cycle. The air then flows into the desiccant cartridge, where it flows through an oil separator which removes liquid oil and solid contaminants.

Air then flows into the desiccant drying bed and becomes progressively drier as water vapor adheres to the desiccant material in a process known as “ADSORPTION.”

Dry air exits the desiccant cartridge through the center of the base assembly. The air then flows to the delivery check valve and also through an orifice into the purge reservoir. The delivery check valve opens, supplying air to the pressure protection valves (A) through (D) simultaneously, the safety valve, and also to the reservoir port of the attached governor. The purge reservoir fills, storing air that will be used to reactivate the desiccant during the purge cycle. This air is available to supply downstream components during the charge mode.

When the air pressure reaches approximately 106 psi, the four pressure protection valves will open and air will be supplied to the primary reservoir, secondary reservoir and accessories. If the pressure protection valves are preset to different values the valves will open in order of lowest setting to highest setting when charging a flat system.

The air dryer and reservoir system will remain in the charge cycle until the air brake system pressure builds to the governor cut-out setting of approximately 130 p.s.i.

### **PURGE CYCLE** (Refer to Figure 3.)

When air brake system pressure reaches the cut-out setting of the governor, the governor unloads the compressor and the purge cycle of the air dryer and reservoir system begins.

The governor unloads the compressor by allowing air pressure to fill the line leading to the compressor unloader mechanism - causing the delivery of compressed air to the AD-IS® air dryer and reservoir system to be suspended.

Similarly, the governor also supplies air pressure to the AD-IS® air dryer and reservoir system purge control channel. The AD-IS® air dryer and reservoir system purge piston moves down in response to this air pressure, causing the purge valve to open to the atmosphere and the turbo cut-off valve to close off the supply of air from the compressor (this will be further discussed in the *Turbo Cut-off Feature* section). Water and contaminants which have collected in the purge valve base are expelled immediately when the purge valve opens. Also, air which was flowing through the desiccant cartridge changes direction and begins to flow toward the open purge valve. Oil and solid contaminants collected by the oil separator are removed by air flowing from the purge reservoir through the desiccant drying bed to the open purge valve.

The initial purge and desiccant cartridge decompression lasts only a few seconds and is evidenced by an audible burst of air at the AD-IS® air dryer and reservoir system exhaust.

The actual reactivation of the desiccant drying bed begins as dry air from the purge reservoir flows through the purge orifice into the desiccant bed. Pressurized air from the purge reservoir expands after passing through the purge orifice; its pressure is lowered and its volume increased. The flow of dry air through the drying bed reactivates the desiccant material by removing the water vapor adhering to it. Approximately 30 seconds are required for the entire contents of the purge reservoir of a standard AD-IS® air dryer and reservoir system to flow through the desiccant drying bed.

The delivery check valve assembly prevents air pressure in the brake system from returning to the air dryer and reservoir system during the purge cycle. After the purge cycle is complete, the air dryer and reservoir system is ready for the next charge cycle to begin.

### **TURBO CUT-OFF FEATURE** (Refer to Figure 3.)

The primary function of the turbo cut-off valve is to prevent loss of engine turbocharger air pressure through the AD-IS® air dryer and reservoir system when the dryer is in the unloaded mode.

At the onset of the purge cycle, the downward travel of the purge piston is stopped when the turbo cut-off valve (tapered portion of purge piston) contacts its mating metal seat in the purge valve housing. With the turbo cut-off valve seated (closed position), air in the compressor discharge line and AD-IS® air dryer and reservoir system inlet port cannot enter the air dryer and reservoir system. In this manner the turbo cut-off effectively maintains turbo charger boost pressure to the engine.

### **PREVENTIVE MAINTENANCE**

**Important:** Review the warranty policy before performing any intrusive maintenance procedures. An extended warranty may be voided if intrusive maintenance is performed during this period. Purge valve maintenance is permissible during the warranty period only when using a genuine Bendix purge valve kit.

Because no two vehicles operate under identical conditions, maintenance and maintenance intervals will vary. Experience is a valuable guide in determining the best maintenance interval for any one particular operation.

#### **Every 900 operating hours, or 25,000 miles or three (3) months:**

1. Check for moisture in the air brake system by opening reservoir drain valves and checking for presence of water. If moisture is present, the desiccant cartridge

may require replacement; however, the following conditions can also cause water accumulation and should be considered before replacing the desiccant:

- A. An outside air source has been used to charge the system. This air did not pass through the drying bed.
- B. Air usage is exceptionally high and not normal for a highway vehicle.

This may be due to accessory air demands or some unusual air requirement that does not allow the compressor to load and unload (compressing and non-compressing cycle) in a normal fashion. Check for high air system leakage. If the vehicle vocation has changed it may be necessary to upgrade the compressor size. Refer to Bendix Specification BW-100-A, Appendix D to determine if any changes are necessary.

- C. Location of the air dryer and reservoir system is too close to the air compressor. Refer to Bendix Specification BW-100-A, Appendix B for discharge line lengths.
- D. In areas where more than a 30 degree range of temperature occurs in one day, small amounts of water can temporarily accumulate in the air brake system due to condensation. Under these conditions, the presence of small amounts of moisture is normal.

**Note:** A small amount of oil in the system is normal and should not be considered as a reason to replace the desiccant cartridge. Some oil at the dryer exhaust is normal.

- 2. Visually check for physical damage such as chaffed or broken air and electrical lines and broken or missing parts.
- 3. Check the AD-IS® air dryer and purge reservoir bolts for tightness. See Figure 1. Re-torque the three air dryer bolts to 360-420 inch pounds and the four purge reservoir bolts to 300-360 inch pounds.
- 4. Perform the *Operation & Leakage Tests* listed in this publication.

### **WARNING!**

**This air dryer and reservoir system is intended to remove moisture and other contaminants normally found in the air brake system. Do not inject alcohol, anti-freeze, or other de-icing substances into or upstream of the air dryer and reservoir system. Alcohol is removed by the dryer, but reduces the effectiveness of the device to dry air. Use of these or other substances can damage the air dryer and reservoir system and may void the warranty.**

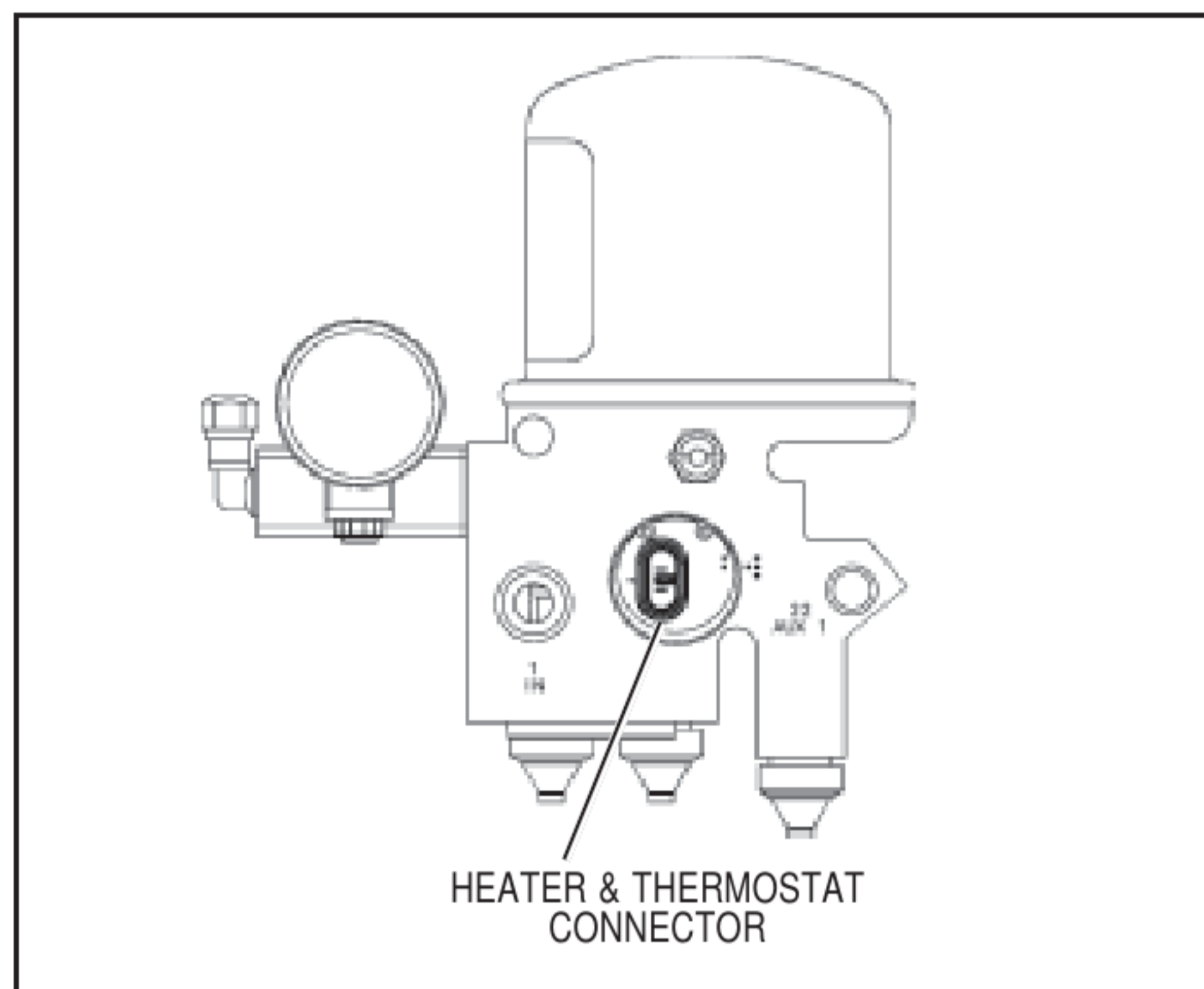

**FIGURE 4 - AD-IS® AIR DRYER AND RESERVOIR SYSTEM HEATER AND THERMOSTAT CONNECTOR**

### **OPERATION & LEAKAGE TESTS (ALSO SEE VIDEO BW2327)**

- 1. Check all lines and fittings leading to and from the air dryer and reservoir system for leakage and integrity. Repair any leaks found.
- 2. Build up system pressure to governor cut-out and note that the AD-IS® air dryer and reservoir system purges with an audible escape of air. Watch the system pressure and note the pressure fall-off for a ten minute period. If pressure drop exceeds, for a single vehicle - 1 psi/minute from either service reservoir; or for tractor trailer - 3 psi/minute from either service reservoir, inspect the vehicle air systems for sources of leakage and repair them. Refer to section entitled *Troubleshooting, Symptoms 1 and 4*.
- 3. **Caution: Be sure to wear safety glasses in case of a purge blast.** Check for excessive leakage around the purge valve with the compressor in the loaded mode (compressing air). Apply a soap solution to the purge valve exhaust port and observe that leakage does not exceed a 1" bubble in 1 second. If the leakage exceeds the maximum specified, refer to section entitled *Troubleshooting, Symptom 4*.
- 4. Build up system pressure to governor cut-out and note that the AD-IS® air dryer and reservoir system purges with an audible burst of air, followed immediately by approximately 30 seconds of air flowing out of the purge valve. "Fan" the service brakes to reduce system air pressure to governor cut-in. Note that the system once again builds to full pressure and is followed by an AD-IS® air dryer and reservoir system purge. If system does not follow this pattern, refer to section entitled *Troubleshooting, Symptoms 5 and 6*.
- 5. Check the operation of the end cover heater and thermostat assembly during cold weather operation as follows:

### A. Electric Power to the Dryer

With the ignition or engine kill switch in the RUN position, check for voltage to the heater and thermostat assembly using a voltmeter or testlight. Unplug the electrical connector at the air dryer and reservoir system and place the test leads on each of the connections of the female connector on the vehicle power lead. If there is no voltage, look for a blown fuse, broken wires, or corrosion in the vehicle wiring harness. Check to see if a good ground path exists.

### B. Thermostat and Heater Operation

**Note:** These tests are not possible except in cold weather operation.

Turn off the ignition switch and cool the thermostat and heater assembly to below 40 degrees Fahrenheit. Using an ohmmeter, check the resistance between the electrical pins in the air dryer and reservoir system connector half. The resistance should be 1.5 to 3.0 ohms for the 12 volt heater assembly and 6.0 to 9.0 ohms for the 24 volt heater assembly.

Warm the thermostat and heater assembly to approximately 90 degrees Fahrenheit and again check the resistance. The resistance should exceed 1000 ohms. If the resistance values obtained are within the stated limits, the thermostat and heater assembly is operating properly. If the resistance values obtained are outside the stated limits, replace the heater and thermostat assembly.

6. **Pressure Protection Valves.** Observe the pressure gauges of the vehicle as system pressure builds from zero. The primary or secondary gauge should rise until it reaches approximately 106 p.s.i. ( $\pm 6$  p.s.i.), then level off (or a momentary slight fall) as the next pressure protection valve opens supplying its reservoir. When that pressure gauge passes through approximately 106 p.s.i. ( $\pm 6$  p.s.i.) there should be an associated leveling off (or momentary slight fall) of pressure as the third and fourth pressure protection valves open. Then the primary and secondary gauges should increase together until they reach their full pressure of approximately 130 psi ( $\pm 5$  psi).

If the AD-IS<sup>®</sup> air dryer and reservoir system does not perform within the pressure ranges as described above, recheck using gauges known to be accurate. If the readings remain outside of the ranges outlined above, replace the AD-IS<sup>®</sup> air dryer and reservoir system. **NOTE:** There are no kits available for the servicing of the pressure protection valves. **WARNING: Do not attempt to adjust or service the pressure protection valves - incorrect pressure protection valve settings can result in automatic application of the vehicle spring brakes without prior warning in the event one of the supply circuits experiences rapid pressure loss.**

## REBUILDING THE AD-IS<sup>®</sup> AIR DRYER AND RESERVOIR SYSTEM

### GENERAL SAFETY GUIDELINES

**WARNING! PLEASE READ AND FOLLOW THESE INSTRUCTIONS TO AVOID PERSONAL INJURY OR DEATH:**

When working on or around a vehicle, the following general precautions should be observed at all times.

1. Park the vehicle on a level surface, apply the parking brakes, and always block the wheels. Always wear safety glasses.
2. Stop the engine and remove ignition key when working under or around the vehicle. When working in the engine compartment, the engine should be shut off and the ignition key should be removed. Where circumstances require that the engine be in operation, **EXTREME CAUTION** should be used to prevent personal injury resulting from contact with moving, rotating, leaking, heated or electrically charged components.

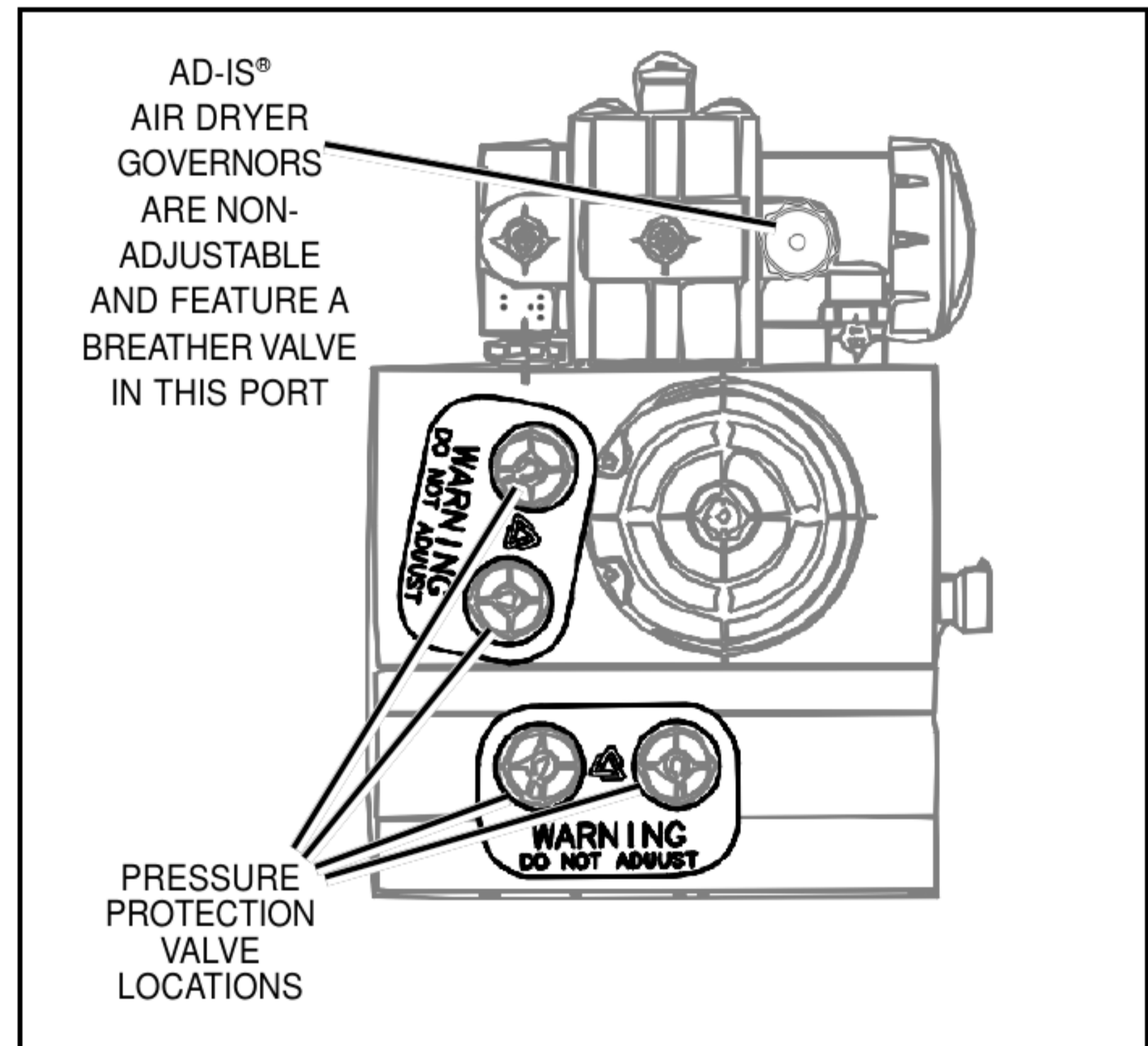

FIGURE 5 - PRESSURE PROTECTION VALVE LOCATIONS

### WARNING:

**DO NOT ATTEMPT TO ADJUST OR SERVICE THE PRESSURE PROTECTION VALVES. INCORRECT PRESSURE PROTECTION VALVE SETTINGS CAN RESULT IN AUTOMATIC APPLICATION OF VEHICLE SPRING BRAKES WITHOUT PRIOR WARNING.**

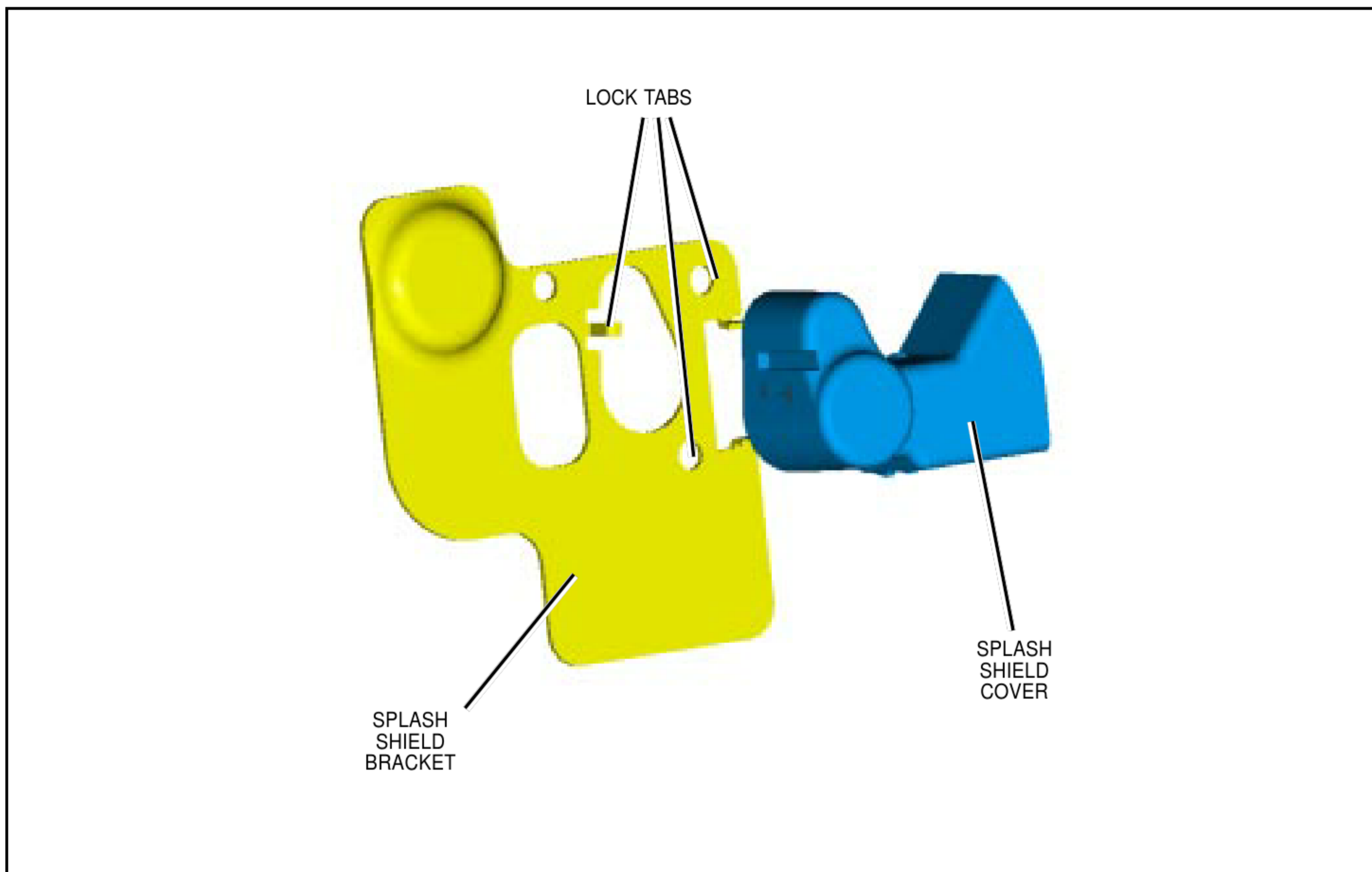

FIGURE 6 - SPLASH SHIELD BRACKET AND COVER - (EXPLODED VIEW)

3. Do not attempt to install, remove, disassemble or assemble a component until you have read and thoroughly understand the recommended procedures. Use only the proper tools and observe all precautions pertaining to use of those tools.
4. If the work is being performed on the vehicle's air brake system, or any auxiliary pressurized air systems, make certain to drain the air pressure from all reservoirs before beginning **ANY** work on the vehicle. If the vehicle is equipped with an AD-IS® air dryer system or a dryer reservoir module, be sure to drain the purge reservoir.
5. Following the vehicle manufacturer's recommended procedures, deactivate the electrical system in a manner that safely removes all electrical power from the vehicle.
6. Never exceed manufacturer's recommended pressures.
7. Never connect or disconnect a hose or line containing pressure; it may whip. Never remove a component or plug unless you are certain all system pressure has been depleted.
8. Use only genuine Bendix® replacement parts, components and kits. Replacement hardware, tubing, hose, fittings, etc. must be of equivalent size, type and strength as original equipment and be designed specifically for such applications and systems.
9. Components with stripped threads or damaged parts should be replaced rather than repaired. Do not attempt repairs requiring machining or welding unless specifically stated and approved by the vehicle and component manufacturer.
10. Prior to returning the vehicle to service, make certain all components and systems are restored to their proper operating condition.
11. For vehicles with Antilock Traction Control (ATC), the ATC function must be disabled (ATC indicator lamp should be ON) prior to performing any vehicle maintenance where one or more wheels on a drive axle are lifted off the ground and moving.

#### GENERAL

When rebuilding or replacing components of the air dryer and reservoir system use only genuine Bendix parts. For ease in servicing, the AD-IS® air dryer and reservoir system has been designed so that any of the following maintenance kits can be installed without removing the air dryer and reservoir system from the vehicle. CAUTION: Always depressurize the air dryer and reservoir system purge reservoir, and all other reservoirs on the vehicle to 0 p.s.i. before servicing the air dryer and reservoir system.

If, after completing the routine operation and leakage tests, it has been determined that one or more components of the air dryer and reservoir system requires replacement or maintenance, refer to the following list to find the appropriate kit(s).

#### **MAINTENANCE KITS AVAILABLE:**

- **Service New Desiccant Cartridge Kit - Part Number 5008414:** This kit contains the parts necessary to change the desiccant cartridge only.
- **Delivery Check Valve Maintenance Kit - Part Number 5004052:** This kit contains the parts necessary to replace the delivery check valve.
- **Purge Valve Maintenance Kit - Part Number 5018313:** This kit contains the parts necessary to replace and relubricate the purge valve sealing rings.
- **Governor/Delivery Check Valve Kit - Part Number 5004049:** This kit contains the parts necessary to replace both the governor and delivery check valve.
- **12 volt or 24 volt Heater and Thermostat Kit - Part Numbers 109495 & 109496:** Contains a replacement heater and thermostat assembly and related components required for replacement.
- **Purge Valve Housing Rebuild Kit - Part Number 5003547:** This kit contains the parts necessary to rebuild the purge valve sub-assembly.
- **Service New Purge Valve Housing Assembly - Part Number 800404:** Contains a service new assembly and related components to change the purge valve sub-assembly.
- **Pressure Protection Valve Boot Replacement- Part Number 5005163.**
- **AD-IS® Air Dryer Replacement:** Replaces the complete air dryer assembly. Includes air dryer assembly and governor.
- **AD-IS® Air Dryer Splash Shield Replacement Kit - Part Number 5006698.**
- **Purge Reservoir Drain Valve:** Replaces the drain valve on the purge reservoir.

#### **SEE THE AD-IS® AIR DRYER CATALOG PAGE (STARTING ON PAGE 08-A-24) FOR A FULL LIST OF MAINTENANCE KITS AVAILABLE.**

**NOTE:** Kits are not available for the servicing of the pressure protection valves (See Figure 5). Do not attempt to adjust or service the pressure protection valves - these are not service items.

#### **TESTING THE AD-IS® AIR DRYER AND RESERVOIR SYSTEM**

Before placing the vehicle in service, perform the following tests:

1. Close all reservoir drain valves.

2. Build up system pressure to governor cut-out and note that the AD-IS® air dryer and reservoir system purges with an audible burst of air, followed immediately by approximately 30 seconds of air flowing out of the purge valve.
3. "Fan" the service brakes to reduce system air pressure to governor cut-in. Note that the system once again builds to full pressure and is followed by a purge at the AD-IS® air dryer and reservoir system exhaust.
4. It is recommended that the total air system be tested for leakage to assure that the AD-IS® air dryer and reservoir system will not cycle excessively.

See Bendix publication BW5057 "Air Brake Handbook."

#### **BRAKING SYSTEM PROTECTION**

The AD-IS® air dryer and reservoir system allows the system to maintain one brake circuit up to about 100 psi even after a pressure loss in the other brake circuit. This allows a vehicle to be moved (in an emergency), but with reduced braking capacity. Compare this to a conventional system where a loss of pressure in one service tank leaves the vehicle with a limited number of reduced braking capacity applications before the parking brakes automatically apply and stay on.

#### **ROADSIDE INSPECTION**

In the event of a roadside inspection the system behavior will be as follows: When the system is charged to governor cut-out, and then one reservoir drain valve is opened, initially both reservoir gauges will fall, however, the AD-IS® air dryer and reservoir system primary and secondary pressure protection valves will close at pressures above 70 psi, protecting the remaining brake circuit from further loss of pressure.

#### **TEMPORARY AIR DRYER AND RESERVOIR SYSTEM BYPASS**

To temporarily bypass the air dryer, the following procedure needs to be followed:

Follow the *Maintenance Precautions* outlined elsewhere in this document.

Make sure that all residual pressure has been released and the air dryer purge reservoir has been drained to 0 p.s.i., then remove the air supply line from the compressor to the inlet port (1/IN). Remove the safety valve from the AD-IS® air dryer and reservoir system body (see Figure 1 for location). Note that a short puff of trapped air may vent from the safety valve port when the valve is being removed. Install a T-fitting into the port. Using any adapters necessary, reinstall the safety valve in one of the branches of the T-fitting. Using any adapters necessary, install the air supply line into the remaining T-fitting port. After testing the T-fitting for any air leakage, by using a soap solution after charging to system



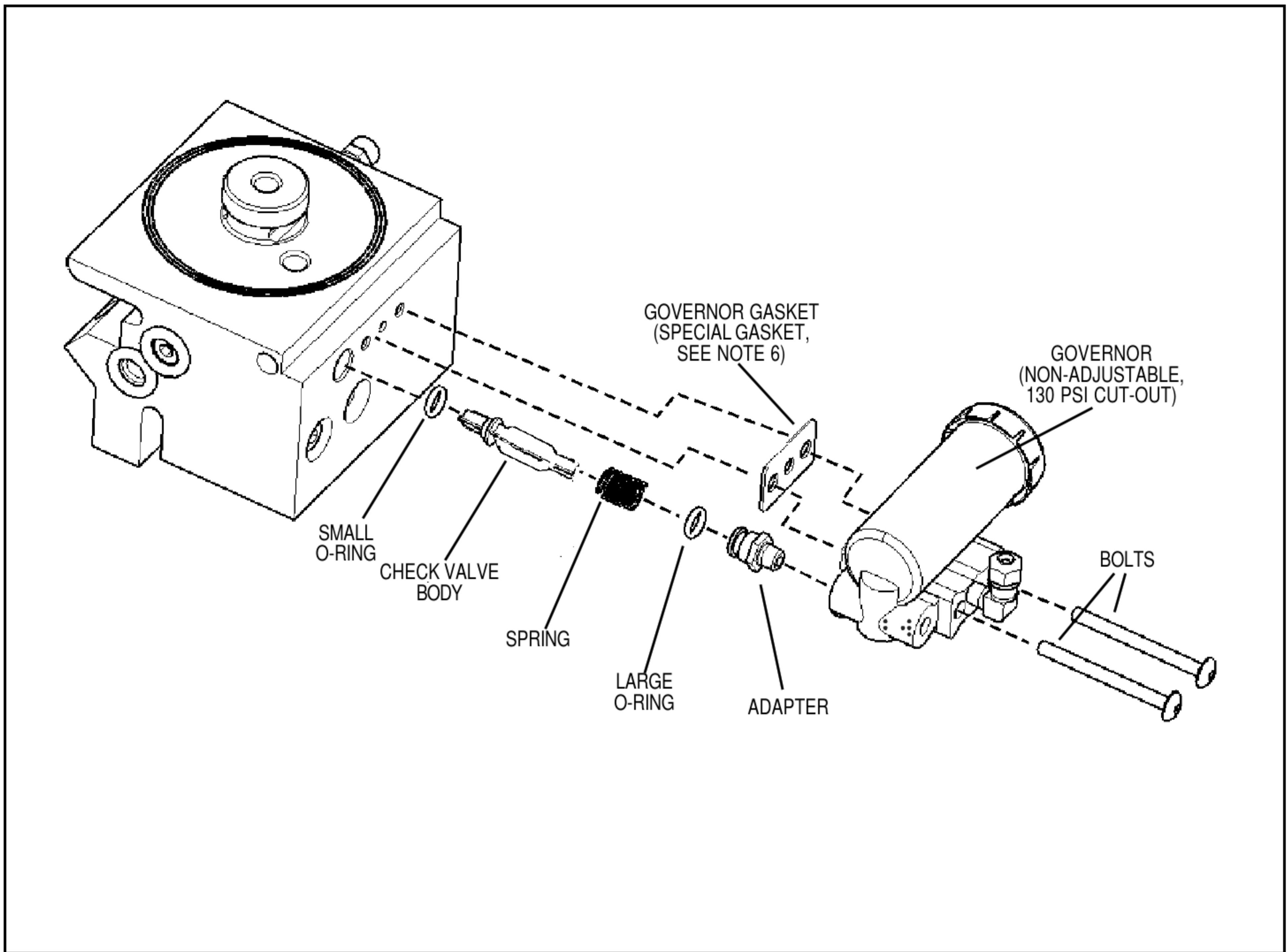

FIGURE 7 - AD-IS® AIR DRYER AND RESERVOIR SYSTEM DELIVERY CHECK VALVE

cut-out pressure (a 1" bubble in 10 seconds is acceptable), the vehicle may be returned to temporary service.

**Note: This is a temporary bypass of the air dryer, and full repair of the unit must be carried out at the earliest opportunity.** With the air dryer and reservoir system removed from the system, contaminants will be entering the air system: reservoirs will need to be manually drained daily until the repairs are completed. At end of each working day, park vehicle and slowly drain pressure through the drain valves – leave open to the atmosphere, for several hours if possible. When repairs are carried out, be sure to check that all reservoirs (including the air dryer purge reservoir) are emptied of all contaminants.

If after bypassing the air dryer and reservoir system the system pressure still does not build, use the following procedure to remove, clean and reinstall the delivery check valve.

#### DELIVERY CHECK VALVE CLEANING PROCEDURE

(Note: This is only required if system pressure does not build after temporary bypass is completed.)

See Figure 7 throughout this procedure. Depressurize the air brake system following the general safety precautions outlined elsewhere in this document. Also, always depressurize the air dryer purge reservoir before servicing the air dryer.

This procedure does not require removal of the AD-IS® air dryer and reservoir system from the vehicle.

1. Remove the line from the governor and mark for easy reinstallation.
2. Remove the bolts attaching the governor to the AD-IS® air dryer and reservoir system and retain for reassembly.
3. Remove the governor from the air dryer. Be aware that a short puff of trapped air may vent when the governor is removed. Retain the governor gasket for reassembly if a new governor gasket is not available. Remove and retain the o-ring from the adapter.
4. The spring/delivery check valve can now be removed.
5. Remove and retain the o-ring from check valve body.

## CLEANING & INSPECTION

1. Use a suitable solvent to clean all metal parts, and use a cotton swab to clean the bore (Note: Do not use abrasives or tools to clean the bore: any scratches caused may necessitate replacing the AD-IS® air dryer and reservoir system.) Superficial external corrosion and/or pitting is acceptable.
2. Clean the o-rings with a clean dry cloth. Do not use solvents.
3. Inspect for physical damage to the bore and the check valve seat. If the bore is damaged (by scratches etc. that would prevent delivery check valve from seating), replace the AD-IS® air dryer.
4. Inspect the delivery check valve, o-rings, etc. for wear or damage. Replace if necessary using the check valve replacement kit available at authorized Bendix parts outlets.
5. Inspect all air line fittings for corrosion and replace as necessary.

## ASSEMBLY

1. Lubricate the smaller o-ring and check valve body with Bendix supplied barium or silicon grease.
2. Install this o-ring on the check valve body by sliding the o-ring over the set of 4 tapered guide lands. The o-ring groove holds the o-ring in its correct location.
3. At the other end of the check valve body, the spring is installed over the set of 4 straight guide lands. When the spring has been pushed to the correct location, the check valve body is designed to hold the end of the spring in position - be sure that the spring is not loose before continuing with this installation.
4. Install the assembled check valve body/o-ring/spring in the delivery port so that the o-ring rests on its seat and the free end of the spring is visible.
5. Grease the adapter and the remaining larger o-ring and install it onto the fitting.
6. Position the Bendix supplied gasket, then insert the governor mounting bolts through the governor and tighten (to 125 in-lbs). **(Note: Do not replace with a standard compressor/governor gasket.)**
7. Reattach line to the governor.
8. Before placing vehicle back into service, check to see that the system pressure now builds to full operational pressure.

# AD-IS® AIR DRYER AND RESERVOIR SYSTEM TROUBLESHOOTING CHART

SYMPTOM	CAUSE	REMEDY
<p>1. Dryer is constantly “cycling” or purging.</p>	<p>A. Excessive system leakage.</p>	<p>A. Test for excessive system leakage. Allowable leakage observed at dash gauge:</p> <p>Single vehicle - 1 psi/minute.</p> <p>Tractor trailer - 3 psi/minute.</p> <p>Using soap solution, test vehicle for leakage at fittings, drain valves and system valves. Repair or replace as necessary.</p>
	<p>B. Defective delivery check valve.</p>	<p>B. Build system pressure to governor cut-out. Wait 1 minute for completion of purge cycle. Using soap solution at exhaust of purge valve, leakage should not exceed a 1" bubble in less than 5 seconds.</p> <p>If a rapid loss of pressure is found, the following procedure will determine if the delivery check valve is malfunctioning:</p> <p>Build system pressure to governor cut-out and allow a full minute for the normal dryer purge cycle to empty the purge reservoir. Switch off the engine and “fan” the brakes so that the system pressure reaches governor cut-in. The purge valve will return to its closed position. The purge reservoir has a drain valve which is opened by moving the center lever away from its closed position. Open the drain valve and wait 10 seconds to allow any residual purge pressure to be released. Release the lever, closing the drain valve. Carefully remove the air dryer cartridge using a strap wrench and then test for air leaking through the center of the threaded boss by applying a soap solution to the boss. Replace the delivery check valve if there is excessive leakage (exceeding a 1" bubble in 5 seconds).</p> <p>Regrease the seal on the air dryer cartridge before reinstalling. Be sure the drain valve on the purge reservoir is not leaking before restoring vehicle to service.</p>
	<p>C. Defective governor.</p>	<p>C. Check governor at both “cut-in” and “cut-out” position for (i) proper pressures and (ii) excessive leakage at fittings and exhaust.</p>
	<p>D. Compressor unloader mechanism leaking excessively.</p>	<p>D. Remove air strainer or fitting from compressor inlet cavity. With compressor unloaded, check for unloader piston leakage. Slight leakage is permissible.</p>

## TROUBLESHOOTING CHART (Continued)

SYMPTOM	CAUSE	REMEDY
2. Water in vehicle reservoirs.	A. Maximum air dryer inlet temperature is exceeded due to improper discharge line length.	A. Check for excessive carbon build up in compressor discharge line. Replace if required. Make certain that discharge line length is at least 6 ft. Increase discharge line length and/or diameter to reduce air dryer inlet temperature.
	B. Air system charged from outside air source (outside air not passing through air dryer).	B. If system must have outside air fill provision, outside air should pass through air dryer.
	C. Excessive air usage - Air dryer not compatible with vehicle air system requirement (Improper air dryer/vehicle application).	C. Refer to Bendix Advanced Troubleshooting Guide for Air Brake Compressors (BW1971) for proper application of the AD-IS® air dryer and reservoir system. An extended purge model (AD-ISEP) is available for many higher air usage vehicles, such as city buses and construction vehicles. If the vehicle is equipped with high air usage accessories such as trailer pump-off systems or central tire inflation, the air for these accessories must by-pass the dryer reservoir system.
	D. Desiccant requires replacement.	D. Replace desiccant cartridge assembly.
	E. Air by-passes desiccant cartridge assembly.	E. If vehicle uses Holset compressor, inspect feedback check valve for proper installation and operation.
	F. Air dryer not purging.	F. Refer to Symptom 6.
	G. Purge (air exhaust) time insufficient due to excessive system leakage.	G. Refer to Symptom 1.

## TROUBLESHOOTING CHART (Continued)

SYMPTOM	CAUSE	REMEDY
3. Safety valve on air dryer "popping off" or exhausting air.	A. Defective AD-IS® air dryer and reservoir system delivery check valve.	A. Test to determine if air is passing through check valve. Repair or replace. Refer to Symptom 1, Remedy B.
	B. Safety valve setting too low (<150 p.s.i.)	B. Replace safety valve.
	C. System pressure too high (>135 p.s.i.)	C. Test with accurate gauge. Replace governor if necessary.
	D. Excessive pressure pulsations from compressor. (Typical single cylinder type).	D. Increase volume in discharge line. This can be accomplished by adding a 90 cubic inch (or larger) reservoir between the compressor and the AD-IS® air dryer and reservoir system.
4. Constant exhaust of air at air dryer purge valve exhaust or unable to build system pressure. (Charge mode.)	A. Air dryer purge valve leaking excessively.	A. With compressor loaded, apply soap solution on purge valve exhaust, to test for excessive leakage. Repair or replace purge valve as necessary. Refer to Technical Bulletin TCH-008-040.
	B. Purge valve frozen open - faulty heater and thermostat, wiring, blown fuse.	B. Refer to paragraph 5 of <i>Operation and Leakage Tests</i> for heater and thermostat test.
	C. Defective AD-IS® air dryer delivery check valve.	C. Refer to Symptom 1, Remedy B.
	D. Leaking Turbo Cut-Off valve.	D. Repair or replace purge valve assembly.
	E. Defective governor.	E. Check governor at both "cut-in" and "cut-out" position for (i) proper pressures and (ii) excessive leakage at fittings and exhaust.
	F. Leaking purge valve control piston quad-ring.	F. Repair or replace purge valve assembly.

## TROUBLESHOOTING CHART (Continued)

SYMPTOM	CAUSE	REMEDY
5. Cannot build system air pressure.	A. Kinked or blocked (plugged) discharge line.	A. Check to determine if air passes through discharge line. Check for kinks, bends, excessive carbon deposits, or ice blockage.
	B. Excessive bends in discharge line (water collects and freezes).	B. Discharge line should be constantly sloping from compressor to air dryer with as few bends as possible.
	C. Pressure protection valve(s) in air dryer will not open.	C. Replace air dryer (pressure protection valves are not serviceable).
	D. Refer to Symptom 4.	D. Refer to Symptom 4, Remedy A.
	E. Refer to Symptom 7.	E. Refer to Symptom 7, Remedies A and B.
6. Air dryer does not purge or exhaust air.	A. Faulty air dryer purge valve.	A. After determining air reaches purge valve control port by installing a T-fitting with a pressure gauge into the governor unloader port, repair purge valve if necessary.
	B. See Causes B, E, and F for Symptom #4.	B. Refer to Symptom 4, Remedies B, E, and F. Also refer to Symptom 1, Remedy B.
7. Desiccant material being expelled from air dryer purge valve exhaust (may look like whitish liquid or paste or small beads.)	A. Faulty dryer cartridge.	A. Replace AD-IS® air dryer cartridge and/or AD-IS® air dryer.
	B. Excessive dryer vibration.	B. Check the AD-IS® air dryer mounting for looseness or damage. Repair mounting and replace cartridge.
8. Unsatisfactory desiccant life.	A. Excessive system leakage.	A. Refer to Symptom 1, Remedy A.
	B. Wrong vehicle application for AD-IS® air dryer.	B. Refer to Symptom 2, Remedy C.
	C. Compressor passing excessive oil.	C. Check for proper compressor installation; if symptoms persist, replace compressor. Refer to Bendix Advanced Troubleshooting Guide for Air Brake Compressor (BW1971).
9. "Pinging" noise excessive during compressor loaded cycle.	A. Single cylinder compressor with high pulse cycles.	A. A slight "pinging" sound may be heard during system build up when a single cylinder compressor is used. If this sound is deemed objectionable, it can be reduced substantially by increasing the discharge line volume.  This can be accomplished by adding a 90 cubic inch (or larger) reservoir between the compressor and the AD-IS® air dryer and reservoir system.

## TROUBLESHOOTING CHART (Continued)

SYMPTOM	CAUSE	REMEDY
10. The air dryer purge piston cycles rapidly in the compressor unloaded (non-compressing) mode.	A. Compressor fails to "unload".	A. Check air hose from governor to compressor for a missing, kinked or restricted line. Install or repair air hose.  Repair or replace compressor unloader.

