



# Air Brake Component Identification

### 1 Dash Valves

Valve Type	Service Literature
MV-3	SD-03-3415
PP-1	SD-03-3611
PP-5	SD-03-3611
PP-7	SD-03-3617
PP-8	SD-03-3611
PP-DC	SD-03-3619
TW-1	SD-03-3602

• MV-3, PP-5™ & PP-DC available in service new only.  
• PP-1 and PP-7 available in service new and remanufactured exchange.

### 8 Brake Valves

Valve Type	Service Literature
E-6	SD-03-817
E-7	SD-03-818
E-8	SD-03-830
E-10	SD-03-817
E-10P	SD-03-830

• E-6, E-7, and E-8 available in service new and remanufactured exchange.  
• E-10 and E-10P available in service new only.

### 11 Tractor Protection Valves

Valve Type	Service Literature
TP-3	SD-03-3652
TP-3DC	SD-03-3656
TP-5	SD-03-3655

• Available in service new and remanufactured exchange.

### 12 Single Check Valves

Valve Type	Service Literature
SC-1™ & SC-2™	SD-03-2201
SC-3™	SD-03-2205

• All SC-1™ and SC-2™ check valves are replaced with an SC-3™. Refer to catalog page for reference.  
• Valves available in service new only.

### 13 Spring Brake Valves

Valve Type	Service Literature
SR-1™	SD-03-4508
SR-7™	SD-03-9043
R-7™	SD-03-4504

• SR-1™ and R-7™ available in service new and remanufactured exchange.

### 15 Relay Valves

Valve Type	Service Literature
R-12	SD-03-1064
R-14	SD-03-1064
R-12DC	SD-03-1068
BP-R1	SD-03-1067

• Available in service new and remanufactured exchange.

### 16 Trailer/Dolly Relay Valves

Valve Type	Service Literature
R-6™	SD-03-1060
RE-6™	SD-03-1151
RE-6NC™	SD-03-1063
R-12P™	SD-03-1063

• Available in service new and remanufactured exchange.

### 2 Quick Release Valves

Valve Type	Service Literature
QR-1	SD-03-901
QR-1C	SD-03-904
QRN	SD-03-905
QR-L	SD-03-906

• QRN™ and QR-L™ available in service new only.  
• QR-1 and QR-1C available in service new and remanufactured exchange.

### 9 Safety Valves

Valve Type	Service Literature	Comments
ST-3™	SD-03-1901	Not used on compressors or AD-IS® air dryers
ST-4™	TCH-001-040	

• Valves available in service new only.

**Specify genuine Bendix® replacement parts every time you service your air brake system.**

- All genuine Bendix replacement parts are manufactured to meet original OE specifications to guarantee quality, reliability and proper operating performance.
- Rely on genuine Bendix replacement parts to keep your air brake system operating efficiently.
- With thousands of authorized Bendix parts outlets across North America, you're never far from quality genuine Bendix Replacement parts.

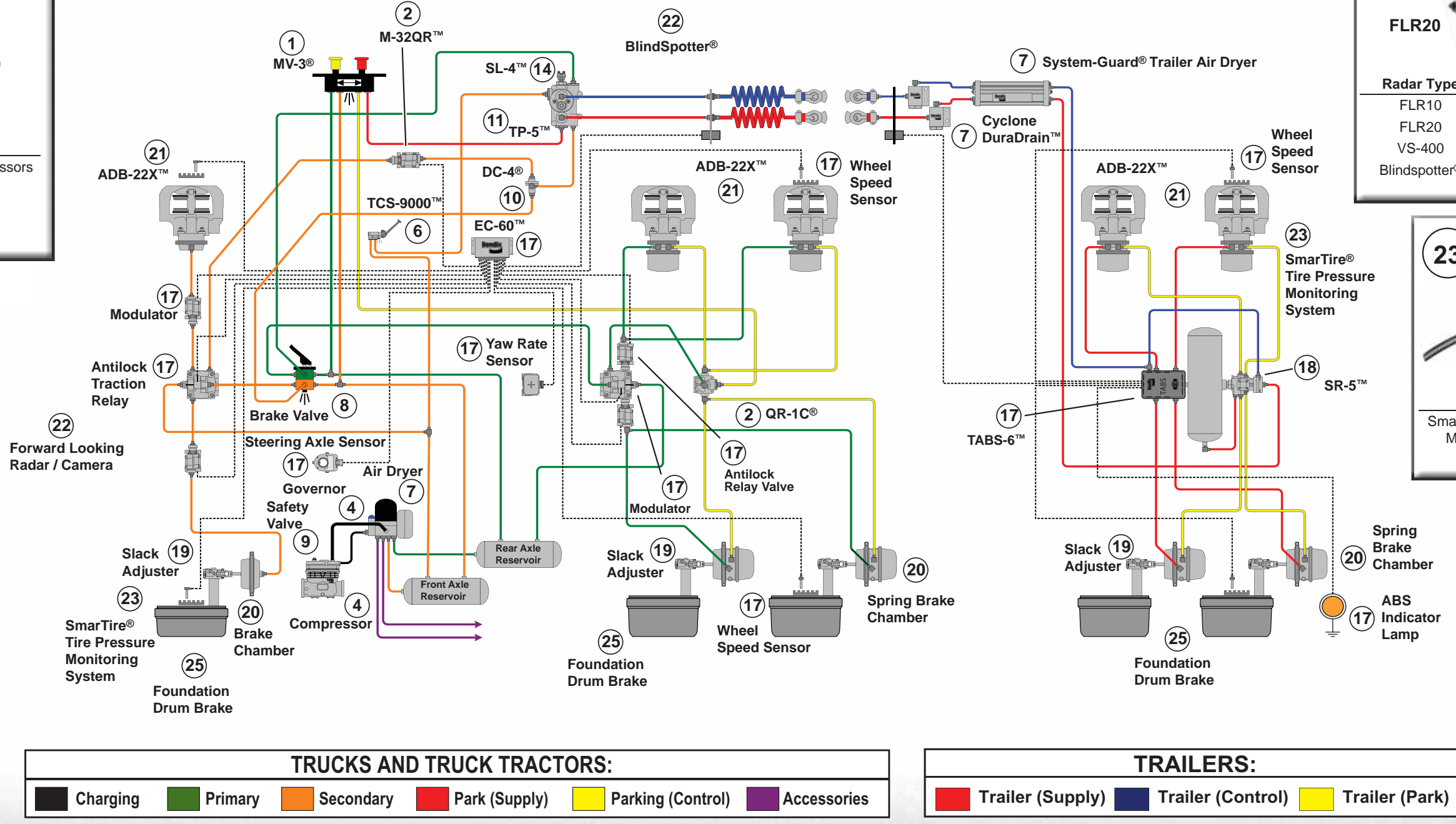

### 22 Radar Systems & Cameras

Radar Type	Service Literature
FLR10	SD-61-4962
FLR20	SD-61-4960
VS-400	BW2771
Blindspotter®	BW2860

• Available in service new only.

### 24 Solenoid Valves

Valve Type	Service Literature
FCS-9700™	SD-03-10432
SMS-9700™	SD-03-10433

• Available service new only.

### 18 Trailer Spring Brake Valves

Valve Type	Service Literature
SR-5™	SD-03-4516
SRC-7000™	SD-03-4656

• SR-5™ available in service new and remanufactured exchange.  
• SRC-7000™ available in service new only.

### 3 Compressor Components

Component	Service Literature
D-2 & D-2A™	SD-01-503
IRV™ Inlet Regulating Valve	SD-01-3408
ICV™ Inlet Check Valve	TCH-001-056 (Tech Bulletin)

• Available in service new and remanufactured exchange.  
• IRV™ & ICV™ available in service new only.

### 5 Limiting Quick Release Valves

Valve Type	Service Literature
LQ-2™	SD-03-950
LQ-4™	SD-03-951
LQ-5™	SD-03-953

• Available in service new and remanufactured exchange.

### 4 Compressors

Compressor Type	Service Literature
BX-2150™	SD-01-331
Tu-Flo® 400	SD-01-326
Tu-Flo® 500	SD-01-326
Tu-Flo® 501	SD-01-337
Tu-Flo® 550	SD-01-333
Tu-Flo® 700	SD-01-335
Tu-Flo® 750	SD-01-344
Tu-Flo® 1000	SD-01-326
Tu-Flo® 1400	Catalog 01-M-1
DuraFlo 596™	SD-01-670
BA-921®	SD-01-3132 and SD-01-690
BA-922®	SD-01-700

• Available in service new and remanufactured exchange.

### 6 Hand Trailer Control Valves

Valve Type	Service Literature
TC-2™	SD-03-813
TC-6™	SD-03-821
TC-7™	SD-03-824
TCS-9000™	SD-03-3674

• TC-2™ available in service new and remanufactured exchange.  
• TC-6™, TC-7™ and TCS-9000™ available in service new only.

Air disc & drum brakes combined on a single axle are shown for pictorial purposes only.  
..... Indicates electrical connection

**For additional information contact the Bendix® Tech Team at 1-800-AIR BRAKE or visit www.bendix.com.**

**Reference Literature (available online)**  
 BW114 Quick Reference Catalog  
 BW5057 Air Brake Handbook  
 BW9100 Air Brake Service Parts Catalog (on a CD)  
 BW9600 Service Data Catalog

### 23 Tire Pressure Monitoring Systems

System Type	Service Literature
SmartTire® Tire Pressure Monitoring System	N/A

• Available in service new only.

### 21 Air Disc Brake

Type	Service Literature
ADB-22X™	SD-23-7541

• Available in OE only.

### 17 Antilock/Traction Stability Components

**Tractor / Truck ABS-6 ECUs**

Component	Service Literature
ATR-1™	SD-13-4811
ATR-2™	SD-13-4812
ATR-3™	N/A
ATR-6™	SD-13-4861z
EC-30™	SD-13-4815
EC-60™ Std. Frame Mount ECU	SD-13-4863
EC-60™ Prem. Frame Mount ECU	SD-13-4863
EC-60™ Prem. Cab Mount ECU	SD-13-4863
EC-60™ Adv. Cab Mount ECU	SD-13-4869
MC-30™	SD-13-4834
M-32™	SD-13-4870
M-32QR™	SD-13-4870
TABS-6™	SD-13-4767
WS-24™ Straight	SD-13-4860
WS-24™ 90°	SD-13-4860
SAS-60™ Steering Angle Sensor	SD-13-4869
SAS-70X™ Steering Angle Sensor	N/A
YAS-60™ Yaw Rate/Lateral Acceleration Sensor	SD-13-4869
YAS-70X™ Yaw Rate/Lateral Acceleration Sensor	SD-13-4869
WS-24™ Wheel Speed Sensor	SD-13-4869

• Available in service new only.

### 25 Foundation Drum Brake

Type	Service Literature
Extended Service (ES)	BW7258
High Performance ES	N/A

• Available in OE only.

### 14 Miscellaneous Components

Component	Service Literature
PR-2™	SD-03-2010
PR-4™	SD-03-2010
SL-4™	SD-06-1800
SL-5™	SD-06-1804
LP-2™	SD-06-1600
LP-3™	SD-06-1600
RV-3™	SD-03-3515
TR-3™	SD-03-4650
SV-1™	SD-03-4020
DV-2™	SD-03-2501
SS-1™	SD-03-4010

• Available in service new only.  
• DV-2™ available in service new and remanufactured exchange.

### 7 Air Treatment

Component	Service Literature
AD-2®	SD-08-2403
AD-9®	SD-08-2412
AD-SP®	SD-08-2418
AD-IP®	SD-08-2414
EverFlow®	SD-08-2415
PuraGuard® QC	SD-08-187B
System-Guard® Trailer Air Dryer	SD-08-2416
Dryer Reservoir Module	SD-98-9808
Cyclone DuraDrain™	SD-08-2402

• AD-SP®, AD-2®, AD-9®, AD-IP® and AD-IS® available in service new and remanufactured exchange.

### 19 Slack Adjusters

Slack Type	Service Literature
Versajust™	SD-05-4630
Manual	SD-05-1200

• Available in service new only.

### 20 Actuators

Actuator Type	Service Literature
Service Brake Chamber	SD-02-1302
EverSure® Spring Brake Chamber	SD-02-4525

• Available in service new only.

### 10 Double Check Valves and Stop Light Switch

Valve Type	Service Literature
DC-4®	SD-03-2202
DS-2™	SD-06-1804
DS-1™	N/A

• Available in service new and remanufactured exchange.  
• Double Check Valves and DS-2™ available in service new only.