

Bendix® TABS-6™ Advanced Multi-Channel Trailer ABS Module

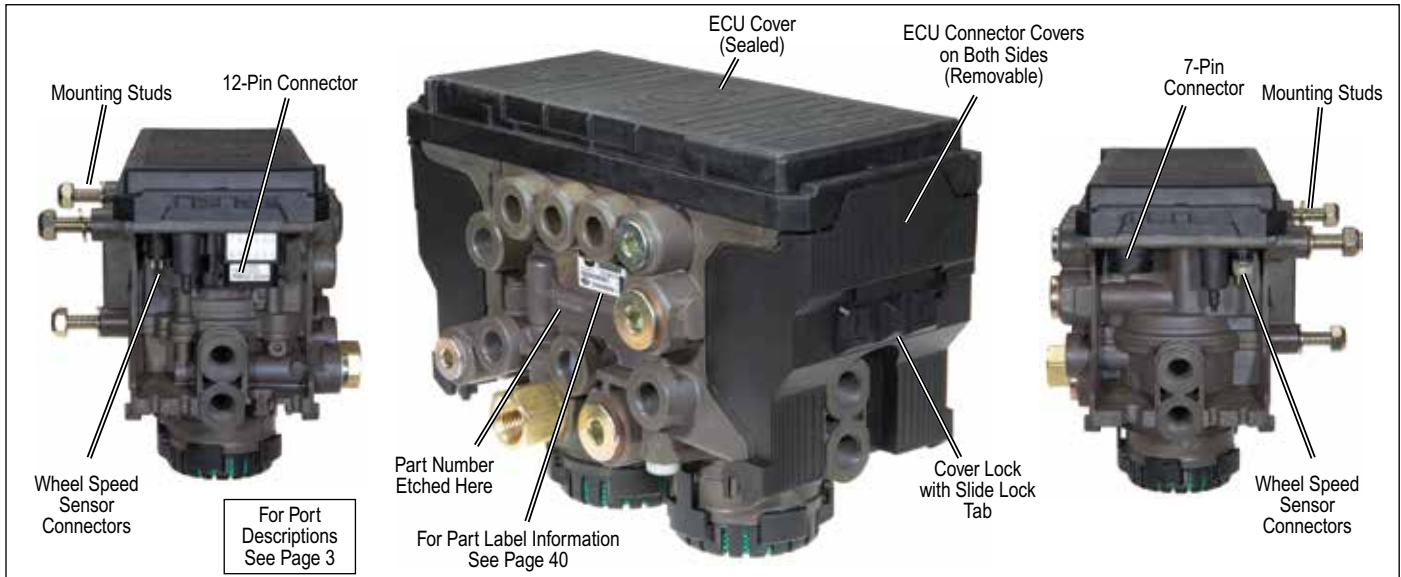

FIGURE 1 - BENDIX® TABS-6™ ADVANCED MULTI-CHANNEL MODULE (BENDIX TABS-6 ADV MC)

1. INTRODUCTION

The Bendix® TABS-6™ Adv MC module is an integrated multi-channel (4S/2M) trailer service brake module controller for air-braked heavy-duty semi-trailers that features Bendix® Antilock Brake System (ABS) and Bendix® Trailer Roll Stability Program (TRSP®).

Installed on semi-trailers, the module acts as a relay valve during normal braking, but during ABS events it will intervene to help maintain vehicle stability and minimize stopping distance by preventing wheel lock-up. The Bendix TRSP monitors the trailer's motion and reduces the risk of roll overs by automatically applying the brakes when a risk of roll over is detected.

This module features:

- A modular design with an integrated Electronic Control Unit (ECU); pressure sensors; a lateral acceleration sensor; and Modulator Relay Valves (MRVs) — eliminating external pigtail harnesses for these components.
- An operating voltage range of 8 - 32 volts.
- An electronic odometer with trip counters & service interval options.
- A scratch-pad feature with up to 1,008 bytes of freely definable read/write text space available for customer use.
- An extended data logging feature, including a resettable drive recorder.

Section TABLE OF CONTENTSPAGE

1. Introduction	1-2
2. Safe Maintenance Practices	2
3. Antilock Brake System (ABS) Operation	3
4. Trailer Roll Stability Program (TRSP) Operation	4
5. Components	5-6
6. Mounting	7
7. Pigtail Wiring Harnesses	7
8. ABS Indicator Lamp	8
9. Bendix® WS-24™ Wheel Speed Sensors	8
10. SAE J2497 (PLC) Diagnostic Link	9
11. SAE J1939 (CAN) Diagnostic Link	9
12. Auxiliary I/O	9
13. Bendix® ABS Flex™ Program	10
14. Customer Scratch Pad	10
15. Power-Up Sequence	10
16. Odometer Function	10
17. Non-Standard Tire Size	11
18. Diagnostic Trouble Code Detection	11
19. Partial ABS Shutdown	11
20. Blink Code Diagnostics	11-12
21. Auxiliary Features	12
22. Diagnostic Trouble Codes (DTCs)	13-19
Troubleshooting Section	20-40

2. SAFE MAINTENANCE PRACTICES

⚠ WARNING! PLEASE READ AND FOLLOW THESE INSTRUCTIONS TO AVOID PERSONAL INJURY OR DEATH:

When working on or around a vehicle, the following general precautions should be observed at all times:

1. Park the vehicle on a level surface, apply the parking brakes, and always block the wheels. Always wear safety glasses.
2. Stop the engine and remove ignition key when working under or around the vehicle. When working in the engine compartment, the engine should be shut off and the ignition key should be removed. Where circumstances require that the engine be in operation, **EXTREME CAUTION** should be used to prevent personal injury resulting from contact with moving, rotating, leaking, heated or electrically charged components.
3. Do not attempt to install, remove, disassemble or assemble a component until you have read and thoroughly understand the recommended procedures. Use only the proper tools and observe all precautions pertaining to use of those tools.
4. If the work is being performed on the vehicle's air brake system, or any auxiliary pressurized air systems, make certain to drain the air pressure from all reservoirs before beginning **ANY** work on the vehicle. If the vehicle is equipped with a Bendix® AD-IS® air dryer system or a dryer reservoir module, be sure to drain the purge reservoir.
5. Following the vehicle manufacturer's recommended procedures, deactivate the electrical system in a manner that safely removes all electrical power from the vehicle.
6. Never exceed manufacturer's recommended pressures.
7. Never connect or disconnect a hose or line containing pressure; it may whip. Never remove a component or plug unless you are certain all system pressure has been depleted.
8. Use only genuine Bendix® brand replacement parts, components and kits. Replacement hardware, tubing, hose, fittings, etc. must be of equivalent size, type and strength as original equipment and be designed specifically for such applications and systems.
9. Components with stripped threads or damaged parts should be replaced rather than repaired. Do not attempt repairs requiring machining or welding unless specifically stated and approved by the vehicle and component manufacturer.
10. Prior to returning the vehicle to service, make certain all components and systems are restored to their proper operating condition.
11. For vehicles with Automatic Traction Control (ATC), the ATC function must be disabled (ATC indicator lamp should be ON) prior to performing any vehicle maintenance where one or more wheels on a drive axle are lifted off the ground and moving.

- A wide variety of electrical inputs/outputs (I/Os) allow the customer to program auxiliary functions such as: automatic Lift Axle Control (LAC); Integrated Speed Switch (ISS); external load sensors; and Auxiliary Design Language (ADL) for customized auxiliary functions.
- A wide range of diagnostic tools for flexible troubleshooting: Blink Codes; SAE J2497 (PLC); SAE J1939 (CAN) Diagnostics; the Bendix® Trailer Remote Diagnostic Unit (TRDU); and the Bendix® Trailer Information Module.
- Support for SAE J2497 Power Line Carrier (PLC) communication to the towing vehicle & diagnostics.
- Support for SAE J1939 (CAN) communication for diagnostics and external devices.
- A pressure-equalizing valve in the sealed ECU housing to give improved protection from water, etc.
- A serviceable nylon filter to help prevent foreign material from entering the control port.
- Locking dust covers to provide electrical connector and cable protection.

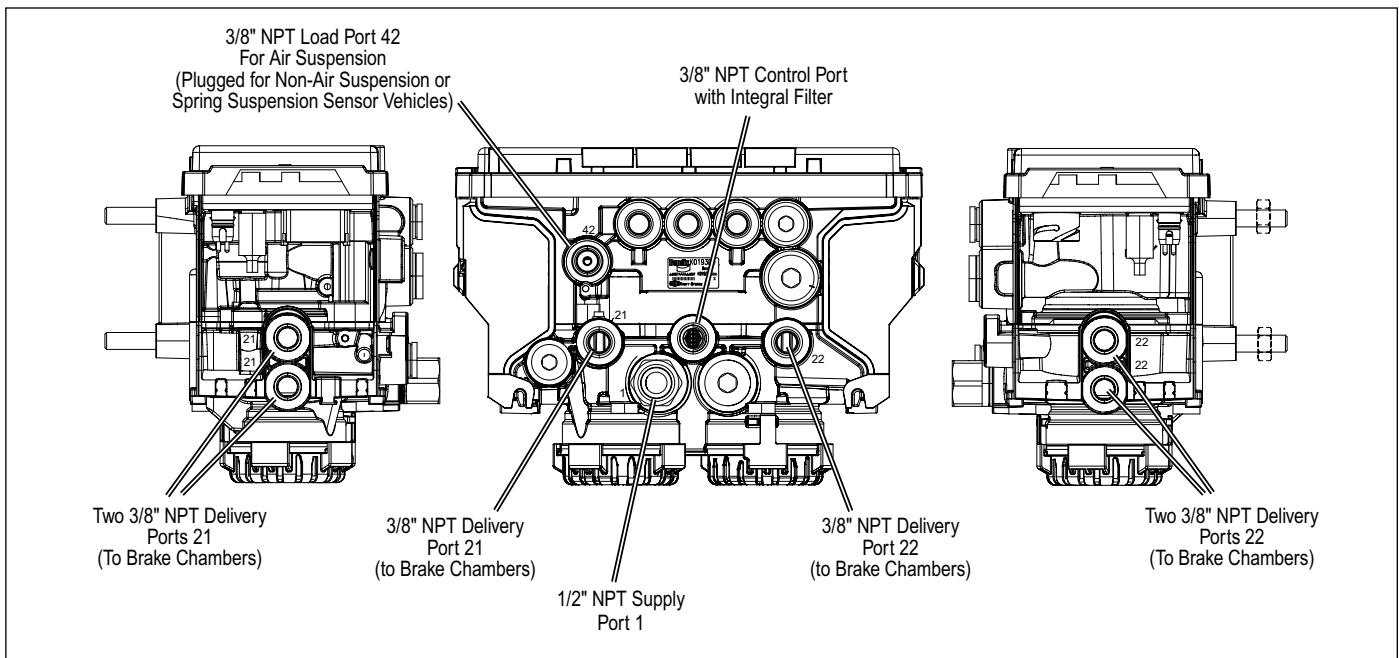

FIGURE 2 - PORTS USED

3. ANTILOCK BRAKE SYSTEM (ABS) OPERATION

The Bendix® TABS-6™ Adv MC module uses wheel speed sensors, modulator relay valves (MRVs); and an ECU to optimize the contact between the tires and the road surface during a braking event where excessive wheel slip — or wheel lock-up — is detected.

When a situation is detected where the system needs to intervene, the ECU will activate the MRVs to apply controlled brake pressure at the wheel ends. Depending on the configuration of the ABS system, interventions may be made on individual wheels, or pairs of wheels. In the case of pairs of wheels, the wheels controlled by a modulator may be either on the same side of the vehicle, or at both ends of an axle.

The TABS-6 Adv MC module ECU is able to modulate the brake pressure with greater speed and accuracy than a driver.

Normal Braking

During normal braking the TABS-6 Adv MC module functions as a standard relay valve. If the ECU does not detect excessive wheel slip, it will not activate the ABS system, and the vehicle will stop with normal braking.

Side Control (Independent Control)

Side control uses a single modulator relay valve to separately control the braking on one or more wheels, on each side of the vehicle.

In the case of braking surfaces with poor overall traction, the side control ABS interventions will maintain the wheels on each side of the vehicle independently, at just under the speed where they would lock up.

Axle Control

Axle control uses a single modulator relay valve to control the wheels at both ends of a given axle (or multiple axles in cases where a single MRV is controlling several axles).

In the case of braking surfaces with poor overall traction (e.g. roads that are worn, slippery, or are made of loose gravel) — or braking surfaces with areas of poor traction (e.g. asphalt roads with patches of ice) — axle control ABS interventions will maintain the wheel that is not slipping at just under the speed that will lock the wheel. The system permits the other wheel (that is experiencing slippage) temporary periods of wheel-lock during the intervention.

Axle control should not be used on 5th wheel dollies or steerable axles.

When intervening on regular traction road surfaces, a system configured for axle control performs similar to a side control, two-modulator system.

ABS Fail-Safe

The Bendix® TABS-6™ Adv MC module is designed to react in a fail-safe manner in the event of a system Diagnostic Trouble Code (DTC). For example, if the ECU detects that a sensor is not responding, an ABS system DTC will be set and the TABS-6 Adv MC module will illuminate the trailer ABS indicator lamp and revert to a fail-safe mode where some, or all, Advanced ABS functions (including TRSP) may not function. Even in cases where the ABS system is completely disabled, the standard pneumatic brake function of the vehicle will still be available, but without the benefits of ABS. The TRSP feature is also disabled with an active ABS system diagnostic code. If the indicator lamp is illuminated, always have the ABS system serviced at the earliest opportunity.

4. BENDIX® TRAILER ROLL STABILITY PROGRAM (TRSP®) OPERATION

⚠ WARNING! During a Bendix® TRSP® system intervention, the vehicle automatically decelerates. The TABS-6 Adv MC module can slow the vehicle with or without the driver applying the brake pedal, and even when the driver applies the throttle.

⚠ WARNING! Even with TRSP system-equipped vehicles, the driver remains responsible for ensuring vehicle stability during operation. The TRSP system only functions within the limits of physics. The system can help mitigate potential vehicle stability incidents, but cannot prevent them in all cases. Other factors — such as driving too fast for the road, traffic or weather conditions, over-steering, an excessively high vehicle Center of Gravity (CG), poor road conditions, or insufficient vehicle maintenance — can cause vehicle instability that is beyond the capability of any stability system to mitigate.

⚠ WARNING! The TRSP system should only be used on specific vehicle platforms that have been validated and approved by BCVS engineering.

⚠ WARNING! The TRSP system is not approved for use on combination vehicles (commonly referred to as “doubles” or “triples”). The TABS-6 Adv MC module shall not be installed on towing trailers that can be used for “double” or “triple” trailer applications (including B-trains).

⚠ WARNING! For vehicles installed with spring suspension systems, care must be taken to prevent damage to the load sensor when lifting the trailer. The linkage rod must be disconnected from the sensor’s rubber boot whenever the frame of the trailer is lifted, dropping the axle(s). This includes situations where a jack is used on the rear bumper or when a crane is used to lift the trailer.

⚠ WARNING! Operating the vehicle with a damaged/ disconnected load sensor could lead to a serious accident. The Bendix® Advanced Trailer ABS used on this vehicle uses sensors, including the load sensor, to assist the Trailer Roll Stability function.

The TRSP system reduces the risk of roll-overs during driving by automatic application of the service brakes when the system detects potential rollover conditions. This is accomplished with monitoring sensors both at the trailer wheel-ends and within the Bendix® TABS-6™ Adv MC module. The Bendix® TRSP® system reacts by applying the trailer service brakes and slowing the vehicle combination.

The Bendix TRSP system uses the following sensors:

- **Lateral Acceleration:** A lateral accelerometer is located within the Bendix TABS-6 Adv MC module. This sensor detects the lateral motion (or “roll”) of the vehicle as it moves. The TABS-6 Adv MC module must be mounted either facing forward (0 degrees) or facing the rear (180 degrees) of the trailer to function correctly — *See Troubleshooting section for full details of acceptable installation locations. Note: Do not attempt to change the location of the module without contacting Bendix for engineering approval.*
- **Vehicle Speed:** The TRSP system obtains information about the vehicle speed and rate of acceleration from the wheel speed sensors.
- **Axle/Bogie Load:** The trailer’s axle load information is obtained either by the use of:
 - (a) An integrated pressure sensor port (P42) of the TABS-6 Adv MC module, where a direct reading of the suspension air spring pressure is taken; or
 - (b) If configured for a mechanical spring deflection sensor, a voltage reading that is proportional to the spring deflection.

TRSP Intervention with Driver Actions

It is quite possible that the driver will also apply the brakes before or during a TRSP intervention by the TABS-6 Adv MC module. In all cases, the Electronic Control Unit (ECU) monitors the driver’s brake application and compares that to the amount of braking the TRSP program has calculated needs to be applied. The pressure delivered to the brakes will always be the higher of the two values.

5. COMPONENTS

Installations of the TABS-6 Adv MC module use the following components:

Internal:

- **Electronic Control Unit (ECU):** The ECU monitors the speed sensor signals, lateral accelerometer sensor signal and various pressure sensors (and if configured, external spring deflection sensor) to determine when ABS and/or TRSP intervention is required. When needed, the ECU actuates the appropriate pressure modulator valves to optimize the brake pressure. The ECU monitors the system to detect and warn the driver of any malfunctions. Diagnostic Trouble Codes (DTCs) are stored in the ECU and can be reviewed to diagnose the TABS-6 Adv MC module system.
- **Lateral Accelerometer Sensor:** The lateral accelerometer sensor senses the lateral movement of the trailer and sends an electrical signal directly proportional to the trailer's lateral acceleration to the ECU.
- **Supply Pressure Sensor:** (non-serviceable, and located within the module.)
- **Internal Load Sensor:**
For air suspension systems, the load sensor port (P42) must be plumbed to a fixed axle air ride bellows. *Note: the sensor must not be plumbed to a lift axle bellows since they are not charged when the axle is not being used.* The function of this sensor is to monitor the pressure and send an electrical signal directly proportional to the trailer's axle load to the ECU.
- **Brake Demand Pressure Sensor:** This sensor monitors the trailer service brake pressure being applied by the driver and sends an electrical signal directly proportional to the driver's brake demand to the ECU.
- **Brake Delivery Pressure Sensors:** These sensors (P21, P22) monitor the trailer service brake pressure that is being delivered to the wheel ends through, or by, the TABS-6 Adv MC module system and sends electrical signals directly proportional to the delivered trailer service brake pressure to the ECU.
- **Modulator Relay Valve (MRV):** MRVs are integrated into the module and are controlled electrically by the ECU to decrease, hold, or allow the full applied brake pressure into the brake chamber to control the braking torque at the wheels.

External:

- **Wheel Speed Sensors (WSS):** Located at selected hubs, wheel speed sensors detect the rotation of individual wheels and send an electrical signal to the ECU proportional to the rotational velocity. *See Figure 3.*
- **External Load Sensor:**
For spring suspension systems, an **external** electrical spring deflection sensor is installed — typically as close to the center (± 5 inches) as possible of an axle with

linkage attached to the center of the axle (but **MUST NOT** be installed on a lift axle), *See Figure 4.* Vehicles with a mechanical load sensor have the port (P42) used for sensing the air suspension system plugged.

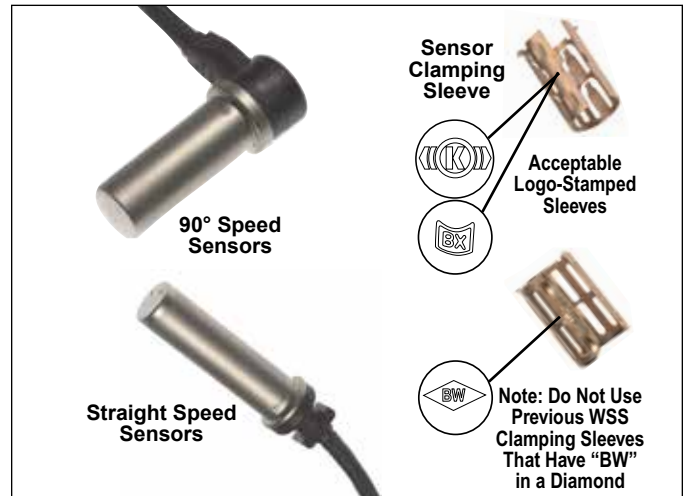
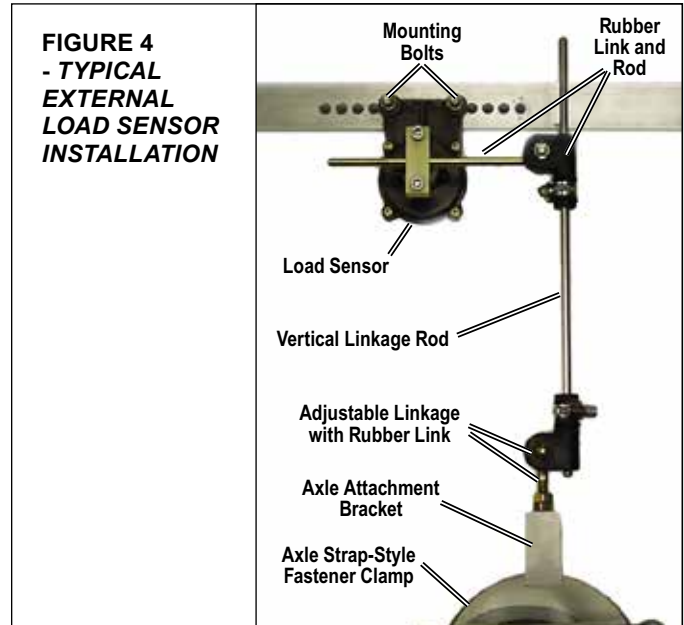

FIGURE 3 - BENDIX® WS-24™ WHEEL SPEED SENSORS



- **Trailer ABS Indicator Lamp:** Controlled by the ECU to show the ABS status, the trailer ABS indicator lamp illuminates when a Diagnostic Trouble Code (DTC) is active. *See Figure 5.* If there are no ABS diagnostic trouble codes present, when ignition power is applied to the ECU, the lamp will illuminate as a bulb check lasting typically two (2), up to six (6) seconds at most.

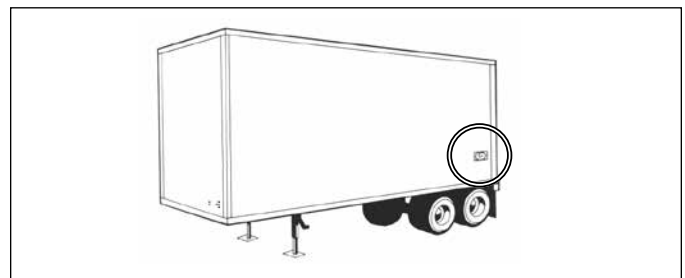

FIGURE 5 - TRAILER-MOUNTED ABS INDICATOR LAMP

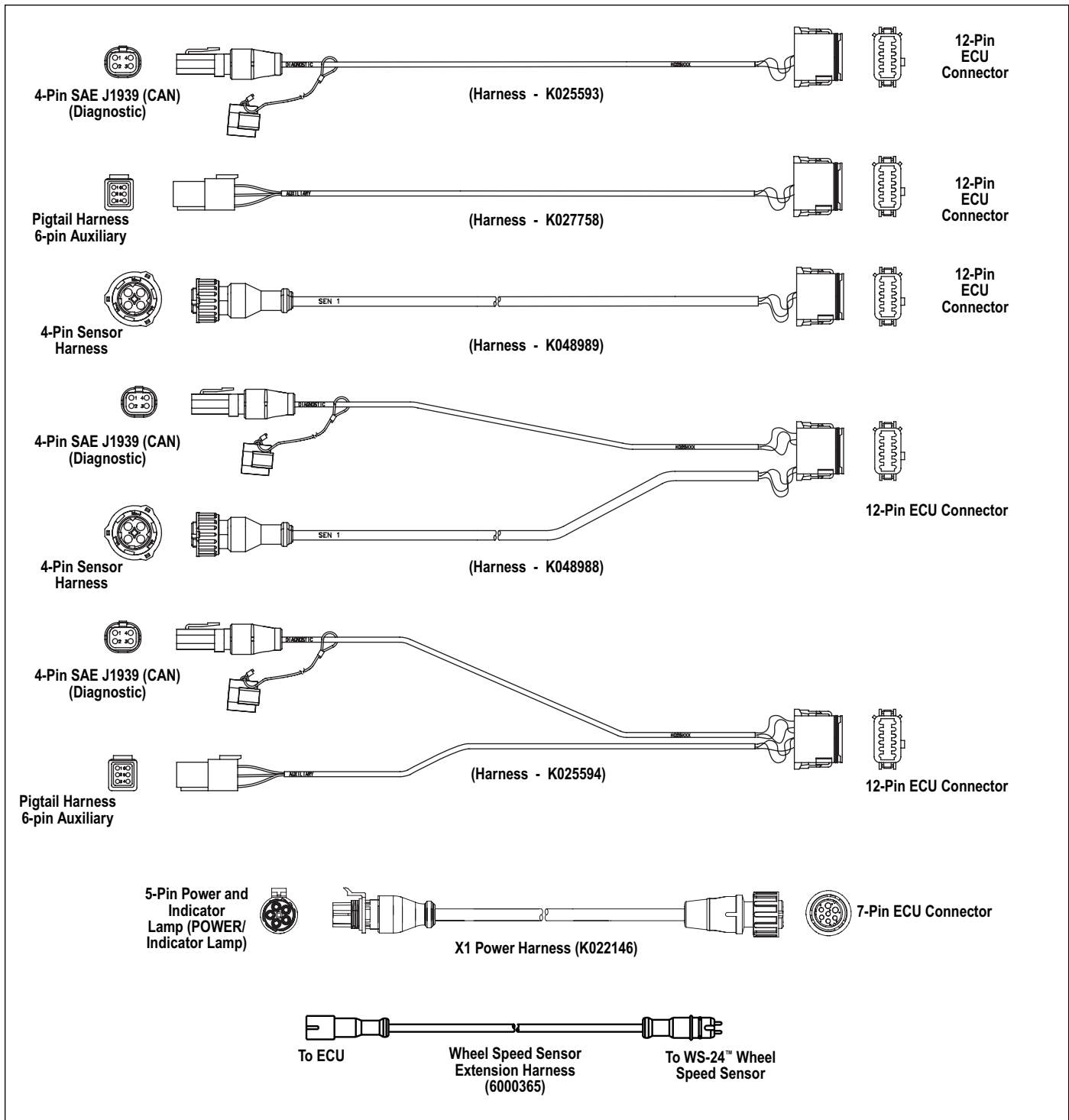

FIGURE 6 - EXAMPLES OF PIGTAIL WIRE HARNESSSES

- **Pigtail Wiring Harness:** A power pigtail harness is required. Auxiliary harnesses are available, as needed. See Figure 6.
- **Lift Axle Sensing:** If a trailer is equipped with a lift axle, then lift axle sensing must be used, unless configured for automatic lift axle control (see below). A pressure threshold switch must be installed in the lift bag for the lift axle and connected to the ECU. The ECU can then monitor the position of the lift axle and will compensate correctly for the load transfer to the other axle(s) when the lift axle is raised.

- **Lift Axle Control:** The Bendix® TABS-6™ Adv MC can be configured to automatically raise (and lower) lift axle(s) when a pre-configured load is sensed.
- **Load Sensor:** If a trailer is equipped with an external electrical spring deflection sensor, See Figure 3, a linkage is attached to an axle (but must not be installed on a lift axle) — within 5 (five) inches of the center of the axle — connects to a load sensor attached to the chassis of the vehicle. The output from the sensor is an electrical signal that is proportional to the spring

deflection. The connection to the Electronic Control Unit (ECU) is via the auxiliary 12-pin connector. See *Figure 6*.

6. MOUNTING

Frame (Chassis) Mount

The Bendix® TABS-6™ Adv MC module provides three M10, 1.18 in. (30 mm.) studs for frame mounting directly to a trailer cross-member. The TABS-6 Adv MC module uses three Class 8 steel M10x1.5 nuts with lock washers, torqued to 354±44.4 in.-lbs (40±5 Nm). A bracket may be used if direct mounting to a cross-member is not possible.

7. PIGTAIL WIRING HARNESSSES

Several pigtail wire harnesses are available to connect the TABS-6 Adv MC module with other trailer system components. See *Figure 6*. Pigtail harnesses are weather-sealed at the connector interface and are clearly labeled for proper installation. Because of the over-molded design of the wiring harnesses, Bendix recommends that if damage or corrosion occurs, the complete harness be replaced.

Wheel Speed Connectors

The TABS-6 Adv MC module includes two primary and two secondary wheel speed sensor connections separate from the main vehicle pigtail harnesses, and each requires a separate harness.

ECU Connectors

The TABS-6 Adv MC module ECU has two connectors (in addition to the wheel speed sensor connectors mentioned above). The primary connector is a 7-pin custom series screw-on type connector used to connect to the vehicle's power pigtail harness. The other connector is a 12-pin Deutsch DT series style connector, used for auxiliary inputs and outputs (I/Os).

POWER AND GROUND

Trailer electrical power is supplied to the TABS-6 Adv MC module from the ignition and brake light circuits.

See *Charts 1 and 2* for output values and pin locations.

Function Mode	Value
Operating Range	8.0 to 32.0 VDC
ECU Active	150 mA @ 12 VDC
ABS Active	2.0 A @ 12 VDC

CHART 1 – VALUES FOR OUTPUTS

Circuit	7-Pin Trailer Conn.	5-Pin ABS Conn.	7-Pin ECU Conn.
Ignition Power PLC (Blue Wire)	7	B	1
Brake Light Power (Red Wire)	4	A	2
Ground (White Wire)	1	E	4
Indicator Lamp (White/Green Wire)	N/A	D	5

CHART 2 – POWER AND GROUND

Power/ABS Indicator Lamp Connector

The TABS-6 Adv MC module pigtail uses a TTMA RP 97-99 5-pin Packard Weather Pack connector for brake light power, constant power, ground and the trailer-mounted ABS indicator lamp.

SAE J1939 (CAN) Connector

See *Figure 6*.

TABS-6 Adv MC module 12-pin auxiliary harnesses typically include a 4-pin connector used for various ECU communications. Typical uses include J1939 diagnostics, and connection to the Bendix® Trailer Information Module.

Auxiliary I/O Connector

The TABS-6 Adv MC module 12-pin auxiliary harness provides an option for up to three auxiliary I/Os.

Examples of uses of the auxiliary connector are:

- Lift axle sensing.
- Rear axle suspension air bag dump.
- SAE J1939 Diagnostics.
- Automatic lift axle control.
- External spring deflection sensor for mechanical spring suspensions.

8. ABS INDICATOR LAMP

Trailer-mounted Lamp

The Bendix® TABS-6™ Adv MC module controls an ABS indicator lamp to show the trailer ABS status. With power supplied by the towing vehicle — if there is an active Diagnostic Trouble Code (DTC), or during the bulb test at start-up — the module illuminates the ABS indicator lamp by providing a 12.0 VDC signal. (The other side of the lamp is grounded.) The ABS indicator lamp output uses pin 5 of the 7-pin connector on the module.

Dash-mounted Lamp (PLC Controlled)

TABS-6 Adv MC modules use SAE J2497 standards to support Power Line Carrier (PLC) communication. The status of the trailer ABS is transmitted over the ignition power wire (the blue wire of the J560 connector) — pin 1 of the 7-pin module connector.

If there is an active DTC, during the bulb check at start-up, the TABS-6 Adv MC module will transmit a signal over the power line to the towing vehicle's ECU. The towing vehicle's ABS controller will then illuminate the trailer ABS indicator lamp mounted on the dash.

9. BENDIX® WS-24™ WHEEL SPEED SENSORS

See *Figure 4*. Wheel speed data is provided to the TABS-6 Adv MC module by the Bendix® WS-24™ wheel speed sensors. Typically, the WS-24 wheel speed sensor is installed in a mounting block that is welded to the axle housing. The WS-24 wheel speed sensors are protected by a stainless steel sheath. They are designed to be used with beryllium copper clamping sleeves (sometimes referred to as a “retainer bushing”, “friction sleeve”, or “clip”) (See *Figure 4*). The clamping sleeve provides a friction fit between the mounting block bore and the WS-24 sensor.

Vehicles have an exciter ring (or “tone ring”) as part of the wheel assembly. (The default setting expects a 100-tooth tone ring to be used. See *Section 17* for more information.) As the wheel turns, the teeth of the exciter ring pass the wheel speed sensor, generating an AC signal which is delivered to the TABS-6 Adv MC module ECU. The signal varies in voltage and frequency as the wheel speed changes.

Vehicle axle and ABS control configurations determine if two, or four, wheel speed sensors are required. See *Figures 20 and 21* for an electrical system schematic showing wheel speed sensor connector pin locations.

CAUTION: Correct wheel speed sensor installation is necessary for optimal ABS operation.

NOTE: If the trailer is equipped with a lift axle that will use wheel speed sensors, it is important that secondary sensors SE and SF be used for this axle. See the system diagrams included in this document. In all cases, the primary wheel speed sensors must be located on the fixed axle. For 2S/2M systems, the fixed axle sensors are SC and SD.

1. For increased corrosion protection Bendix recommends that a high-temperature rated silicon- or lithium-based grease be applied to the interior of the mounting block, the sensor, and to a new clamping sleeve.
2. Install the new clamping sleeve fully into the block, with the retaining tabs toward the inside of the vehicle. Please note that Bendix WS-24 wheel speed sensors must use the correct clamping sleeve to avoid problems associated with reduced retention force, such as sensor movement and resulting ABS trouble codes. See *Figure 4*.
3. Gently push (DO NOT STRIKE) the sensor into the mounting block hole until it bottoms out on the face of the tone ring. Secure the cable lead wire to the knuckle/ axle housing 3-6 inches from the sensor.
4. Apply a moderate amount of dielectric non-conductive grease to both the sensor and harness connectors.
5. Engage the connectors, and push them together until the lock tab snaps into place. It is permissible to use an extra wire retainer (part number 300122, or equivalent), if available, to hold the connectors together.

The friction fit allows the WS-24 sensor to slide back and forth under force, but to retain its position when the force is removed. When the WS-24 sensor is inserted all the way into the mounting block and the wheel is installed on the axle, the hub exciter contacts the sensor, which pushes the sensor back. Also, normal bearing play will “bump” the sensor away from the exciter. The combination of these two actions will establish a running clearance, or air gap, between the sensor and exciter.

CAUTION: Wheel bearing maintenance is an important part of keeping the wheel speed sensors in the correct position. Excessive wheel end play can result in DTCs in cases where the sensor is pushed too far away from the tone ring for a good signal to be produced. Maintain wheel bearings per the manufacturer's recommendations.

10. SAE J2497 (PLC) DIAGNOSTIC LINK

All newer towed vehicles transmit a signal over the power line to the towing vehicle ABS ECU. The signal, using a heavy vehicle industry standard known as Power Line Carrier (PLC\J2497), is broadcast by the trailer ABS ECU over the blue wire (ignition power line) of the SAE J560 connector and controls an in-cab trailer ABS indicator lamp. See Figures 7 and 8.

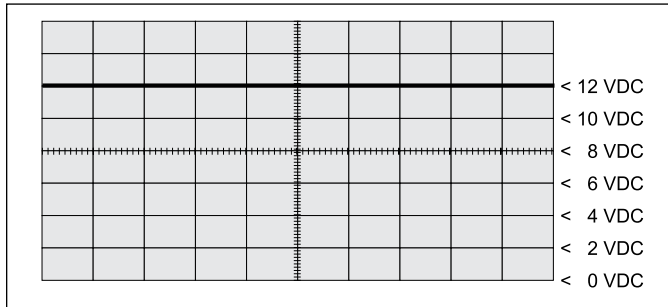

FIGURE 7 - POWER LINE WITHOUT PLC SIGNAL

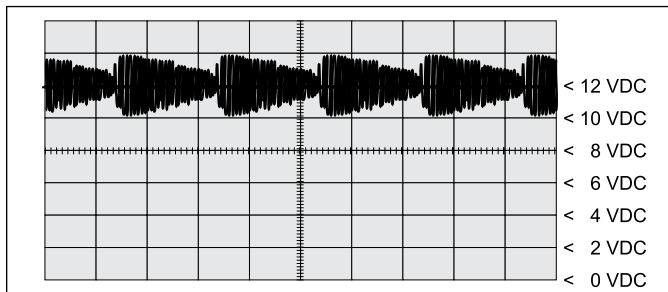

FIGURE 8 - POWER LINE WITH PLC SIGNAL

The Bendix® TABS-6™ Adv MC module provides a data link for PLC communication following the SAE J2497 standard.

Bendix® ACom® diagnostics software (version 6.1 and higher) and the Bendix® Trailer Remote Diagnostic Unit (TRDU™) both support PLC communication with the TABS-6 Adv MC module.

PLC communication is applicable for 12-volt vehicle applications only. The PLC communication is disabled for voltages greater than 18 volts.

Identifying and Measuring the PLC Signal

A TABS-6 Adv MC module will continuously broadcast PLC messages that indicate trailer ABS status. At power-up, or during a trailer ABS diagnostic Trouble Code (DTC) condition, the TABS-6 Adv MC module will signal the tractor ABS unit to illuminate the dash-mounted trailer ABS indicator lamp.

Diagnostic tools are available that detect the presence of a PLC signal and perform further system diagnostics directly, using the power line. For more information on these diagnostic tools, contact Bendix or refer to your local authorized Bendix dealer or distributor.

An oscilloscope can also be used to verify the presence and strength of a PLC signal on the power line. The PLC signal is an amplitude and frequency modulated signal. Depending on the load on the power line, the amplitude of the PLC signal can range from 2.5 mV p-p to 7.0 V p-p.

Suggested oscilloscope settings are (AC coupling, 1 volt/div, 100 µsec/div). The signal should be measured on pin 7 of the J560 connector at the nose of the trailer.

11. SAE J1939 (CAN) DIAGNOSTIC LINK

The TABS-6 Adv MC module provides a data link for transmitting CAN information following the SAE J1939 standard.

Bendix® ACom® diagnostics software (version 6.1 and higher) and the Bendix® Trailer Information Module both support CAN communication with the TABS-6 Adv MC module.

Ignition power must be provided to the TABS-6 Adv MC module for the diagnostic link to be active.

12. AUXILIARY I/O

The TABS-6 Adv MC module provides for up to six auxiliary input/output (I/O) functions. See Chart 3.

Name	12-Pin ECU Conn. (X2)	Auxiliary Functions	Auxiliary Type
Aux I/O 1 (AuxIO1)	1	High-Side Driver	Output
		Digital Input	Input
Aux I/O 2 (AuxIO2)	2	High-Side Driver	Output
		Digital Input	Input
Aux I/O 3 (AuxIO3)	3	High-Side Driver	Output
		Digital Input	Input
AuxRet 12	11	Low-Side Driver	Output
AuxRet 3	12	Low-Side Driver	Output
Sens_Sup	4	+5V Sensor Supply	Output
Sens_In	5	Analog Input	Input
Sens_Gnd	6	Low-Side Driver	Input

CHART 3 – AUXILIARY I/OS

Bendix® ACom® diagnostic software (version 6.1 and higher) supports the configuration of the TABS-6 Adv MC module auxiliary I/Os.

13. BENDIX® ABS FLEX™ PROGRAM

The Bendix ABS Flex program uses Auxiliary Design Language (ADL) to allow customized auxiliary functions to be carried out by the Bendix® TABS-6™ Adv MC module. Programs developed in the ABS Flex program may be downloaded at the production line, or in the field, to control non-braking functions of the trailer.

For example, the ABS Flex program can potentially communicate the status of: tire inflation and/or temperature; reefer temperature; load presence; slider pin position; lift axle position; proximity/reverse alarm; and vehicle weight.

ABS Flex programs monitor the auxiliary I/Os and/or the SAE J1939 (CAN) and SAE J2497 (PLC) data links. Contact your Bendix Account Manager to discuss an ABS Flex program for your vehicle(s).

14. CUSTOMER SCRATCH PAD

The TABS-6 Adv MC module has a Customer Scratch Pad feature which allows the customer, or end-user, to store up to 1,008 bytes of information. This information can then be read using the Bendix® ACom® diagnostic software (version 6.1 and higher).

15. POWER-UP SEQUENCE

At power-up, the TABS-6 Adv MC module performs a series of self-checks that can assist a technician to determine the ABS system status and configuration.

Trailer ABS Indicator Lamp

At power-up, with no detected Diagnostic Trouble Codes (DTCs), the trailer ABS indicator lamp will illuminate for approximately two (2) to six (6) seconds as a bulb check and then turn off. See Figure 9.

If any active ABS- or TRSP-related diagnostic codes are present, the trailer ABS indicator lamp will remain illuminated.

For non-ABS or TRSP-related DTCs, such as auxiliary functions, at power-up the trailer ABS indicator lamp will turn on for approximately six and a half (6.5) seconds as an extended bulb check and then turn off.

If a PLC-ready towing vehicle and trailer are powered at the same time, the TABS-6 Adv MC module will also trigger a bulb check on the dash-mounted trailer ABS indicator lamp.

Modulator Chuff Test at Power-Up

At power-up, the TABS-6 Adv MC module activates a modulator chuff test. This electrical and pneumatic ABS modulator test can help the technician identify problems with modulator installations and/or wiring.

With brake pressure applied, a properly installed modulator will cause two rapid audible chuffs of air pressure. The TABS-6 Adv MC module will not perform a modulator chuff test with an active ABS DTC.

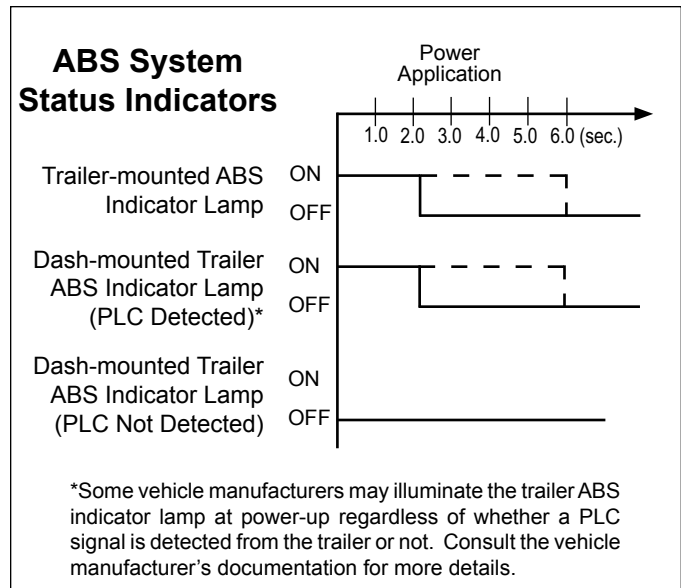

FIGURE 9 - TRAILER ABS LAMP POWER-UP SEQUENCE

16. ODOMETER FUNCTION

Odometer

The TABS-6 Adv MC module includes an odometer function to provide a means of storing the accumulated mileage of the vehicle. The mileage is computed by using information received from the vehicle wheel speeds sensors.

This feature is accurate to within 0.62 miles per power-up and will typically store mileage up to 1,000,000 miles. The mileage can be displayed using PC diagnostics, a Bendix® Trailer Information Module, Bendix® Trailer Remote Diagnostic Unit (TRDU™), or through blink codes.

Whenever the TABS-6 Adv MC module is towed using a pre-1997 tractor (with no constant power supplied to the trailer), no information about mileage will be stored during that time, and the mileage can be considered out-of-calibration.

Trip Counter

The TABS-6 Adv MC module provides a counter to record the trip mileage. The feature can be accessed using PC Diagnostics or the Bendix® Trailer Information Module.

Service Interval

The TABS-6 Adv MC module provides a feature that can be used to indicate a service interval for the trailer. The service interval can be accessed using PC diagnostics or the Trailer Information Module. If configured, the TABS-6 Adv MC module can flash the indicator lamp when the vehicle is at standstill to indicate when the service interval has been exceeded.

17. NON-STANDARD TIRE SIZE

The Bendix® TABS-6™ Adv MC module allows for tire rolling radius and tone ring tooth count parameters to be set for the axle being sensed using the Bendix® ACom® diagnostic software. These adjustments may be necessary for the module to accurately calculate the vehicle velocity and odometer mileage. Wheels of the same axle must have, and be set to the same, rolling radius and tone ring tooth count. Refer to the manufacturer's tire specification for correct values.

The tone ring size is defaulted to 100 teeth, and the tire-rolling radius is defaulted to 511 revolutions per mile. These parameters can be adjusted as shown in Chart 4.

Tone Ring Size	Tire Rolling Radius – Allowable Range
60 teeth	712 to 1005 rpms
80 teeth	512 to 801 rpms
90 teeth	456 to 711 rpms
100 teeth	410 to 640 rpms
120 teeth	356 to 502 rpms

CHART 4 – TONE RING SIZE TO TIRE ROLLING RADIUS

18. DIAGNOSTIC TROUBLE CODE DETECTION

The TABS-6 Adv MC module contains self-testing diagnostic circuitry that monitors the ABS components and wiring.

When the TABS-6 Adv MC module senses an erroneous system condition, it activates the external trailer-mounted ABS indicator lamp; disables all or part of the affected ABS and/or TRSP functions; and it stores the Diagnostic Trouble Code (DTC) in memory, so that the information is retained even when the power is removed. The TABS-6 Adv MC module also uses PLC communications to send the system status to the towing vehicle.

For some trouble codes, the TABS-6 Adv MC module will automatically reset (“self-heal”) the active DTC when the error is corrected (e.g. when a wheel speed sensor is re-aligned). However, repeated occurrences of a given DTC can cause the code to “latch” — that is, be retained as active — even if the condition is only intermittent. Once the code is latched, a manual reset will be necessary. Technicians can use these latched codes to assist them in troubleshooting intermittent errors. After the problem is repaired, the DTC can be reset using blink code diagnostics, or with a diagnostic tool.

When a DTC self-heals or is manually reset, the code remains stored as an inactive DTC in the ECU memory. This inactive DTC can be retrieved using blink code diagnostics or with a diagnostic tool.

19. PARTIAL ABS SHUTDOWN

Depending on the DTC detected, the ABS ECU will partially or completely disable the ABS and/or Bendix® TRSP® functionality. In cases where the ABS is completely disabled, the vehicle reverts to normal braking (without ABS or TRSP interventions). Always repair ABS DTCs at the earliest opportunity.

ECU Diagnostic Trouble Codes

All ABS functions are completely disabled. The system reverts to normal braking.

Voltage Diagnostic Trouble Code

The operating voltage range is 8.0 to 32.0 VDC. If the voltage is detected as being out of range, the ABS and TRSP system braking features will be disabled, and the system reverts to normal braking. When the correct voltage level is restored, full ABS and TRSP is typically available again.

20. BLINK CODE DIAGNOSTICS

The TABS-6 Adv MC module provides diagnostic functions through blink code diagnostics. This means that the technician — even without diagnostic tools — can read a series of ABS indicator lamp blinks to diagnose the DTCs being generated.

With no towing vehicle attached, enter the blink code diagnostics mode by providing constant power to the ignition circuit and then toggling the brake light power input the specific number of times shown in Chart 5, for the desired mode.

With a parked towing vehicle attached, apply ignition power, and after the power-up sequence is complete, enter the diagnostics mode by depressing and releasing the brake pedal the specific number of times shown in Chart 5, for the desired mode.

Cycles to Enter Desired Mode	
Mode	Cycles
Active DTC Retrieval	3
Inactive DTC Retrieval (DTC History)	4
Clear Active DTCs	5
Odometer Mileage Display	7

CHART 5 – BLINK CODE INFORMATION

Depending on the blink code mode activated, the TABS-6 Adv MC module will blink the trailer-mounted ABS indicator lamp to display: active DTC codes; inactive DTCs; and odometer mileage. Blink code diagnostics can also be used to clear active DTCs.

Wait until after the modulator chuff test before activating the brake light power. Alternatively, wait five (5) seconds.

Note: If certain Diagnostic Trouble Codes (DTCs) are set, typically where modulator DTCs have occurred, the chuff test may not run.

Following a single display of all available messages, the ABS indicator lamp will remain on for five seconds and then return to normal operating mode. Blink code diagnostics can only be activated following a power-up, where wheel speeds have not been detected. If the vehicle moves during the blink code diagnostics mode, the Bendix® TABS-6™ Adv MC module will cancel the blink code diagnostics and return to normal operating mode.

Blink code diagnostics must be activated within the first 15 seconds of ignition power being applied.

If brake light power is continuously applied for greater than five seconds, blink code diagnostics will be disabled until the next time the ignition power is cycled.

Display Active Diagnostic Trouble Codes (DTCs)

To display active codes, apply ignition power and depress and release the brake pedal three (3) times within 15 seconds (allowing one second between each application). Following this activation, there will be a five (5) second delay followed by a blink code display sequence of all active DTCs. (See pages 13-19 for more information about DTCs.)

Display Inactive Diagnostic Trouble Codes (DTCs)

To display inactive DTCs — those that are not currently set, but have occurred and are stored in the ECUs memory — apply ignition power and depress and release the brake pedal four (4) times within 15 seconds. Following this activation, there will be a five (5) second delay followed by a blink code display sequence of all inactive DTCs stored. (See pages 13-19 for more information.)

Reset Active Diagnostic Trouble Codes

To reset active codes, apply ignition power and depress and release the brake pedal five (5) times within 15 seconds. Following activation, there will be a five (5) second delay followed by:

- (a) If no DTCs remain, a blink code message of 1-1, (System Fully Operational - No DTCs Detected) and the ABS indicator lamp will cease to be illuminated; or
- (b) If there are remaining active DTCs, a sequence of blink codes will display all of the remaining active DTCs, and the ABS indicator lamp will stay on.

Resetting active DTCs with blink code diagnostics does not clear information from trouble code history. Both blink code diagnostics or diagnostic tools can retrieve inactive DTCs, but only diagnostic tools can clear this information.

Display Odometer Mileage

To display the trailer odometer mileage, apply ignition power and depress / release the brake pedal seven (7) times within 15 seconds. Following activation, there will be a five (5) second delay followed by a blink code display of the odometer information (x1000).

Example: 152,431 miles will be displayed as: 152 (x1000) or 1 blink (pause); 5 blinks (pause); 2 blinks.

Zeros will be displayed by the ABS indicator lamp strobing twice.

Odometer mileage cannot be altered with blink code diagnostics. Complete odometer information can be retrieved using a diagnostic tool.

21. AUXILIARY FEATURES

Rear Axle Suspension Dump

Some spread-axle trailers are equipped with a rear-axle suspension air bag dump feature to assist with cornering at low speeds. The TABS-6 Adv MC module may be configured to use this feature. When this feature is used below a pre-determined threshold vehicle speed, the ECU will partially exhaust the rear axle air suspension bags, and then re-inflate them when the vehicle speed rises above the threshold. For more information about this feature, contact your local Bendix Account Manager by calling 1-800-AIR-BRAKE (1-800-247-2725).

Lift Axle Control (Automatic)

The TABS-6™ Adv MC module can be configured to automatically raise a lift axle when the load on the trailer drops below a configured level. Changes to the trailer to allow for this feature include the use of one of the auxiliary outputs to operate a lift axle control valve.

22. DIAGNOSTIC TROUBLE CODES (DTCs)

1st Digit	2nd Digit	Diagnostic Code Description	Possible Causes / Repair Information	J1587 (SID/FMI)	J1939 (SPN/FMI)
1	1	No diagnostic codes	<ul style="list-style-type: none"> The Bendix® TABS-6™ Adv MC module system is fully operational – no diagnostic codes are detected. 	000/00	000/00
Wheel Speed Sensors (WSS); “S-C”, “S-D”, “S-E”, “S-F”					
2	1	Large Air Gap: Sensor “S-C”	Dynamic Wheel Speed Sensor DTC - large air gap between sensor and tone ring. Go to Section E on Page 38.	001/00	789/00
3	1	Large Air Gap: Sensor “S-D”		002/00	790/00
4	1	Large Air Gap: Sensor “S-E”		003/00	791/00
5	1	Large Air Gap: Sensor “S-F”		004/00	792/00
2	2	Shorted or open wire: Sensor “S-C”	Static Wheel Speed Sensor DTC - shorted or open sensor wire. Go to Section E on Page 38.	001/03 001/04	789/03 789/04
3	2	Shorted or open wire: Sensor “S-D”		002/03 002/04	790/03 790/04
4	2	Shorted or open wire: Sensor “S-E”		003/03 003/04	791/03 791/04
5	2	Shorted or open wire: Sensor “S-F”		004/03 004/04	792/03 792/04
2	3	Dynamic Issue: Sensor “S-C”	Dynamic Wheel Speed Sensor DTC - incorrect wheel speed signal detected while vehicle is in motion. Go to Section E on Page 38.	001/08 001/01 001/02	789/08 789/01 789/02
3	3	Dynamic Issue: Sensor “S-D”		002/08 002/01 002/02	790/08 790/01 790/02
4	3	Dynamic Issue: Sensor “S-E”		003/08 003/01 003/02	791/08 791/01 791/02
5	3	Dynamic Issue: Sensor “S-F”		004/08 004/01 004/02	792/08 792/01 792/02
2	4	Tire Diameter Out of Range: Sensor “S-C”	<ul style="list-style-type: none"> Verify the correct tire size as desired. Verify the proper tire inflation. Verify the correct number of exciter/tone ring teeth. Verify that the TABS-6 Adv MC module ECU has been programmed with the correct tire size and tone ring settings. 	001/13	789/13
3	4	Tire Diameter Out of Range: Sensor “S-D”		002/13	790/13
4	4	Tire Diameter Out of Range: Sensor “S-E”		003/13	791/13
5	4	Tire Diameter Out of Range: Sensor “S-F”		004/13	792/13

Diagnostic Trouble Codes (DTCs) (continued)

1st Digit	2nd Digit	Diagnostic Code Description	Possible Causes / Repair Information	J1587 (SID/ FMI)	J1939 (SPN/ FMI)
Trailer Power					
6	1	Over-voltage	Power Supply DTC - trailer power above 32 volts. Go to Section D on Page 37.	251/03	3597/03
6	2	Low-voltage	Power Supply DTC - trailer power below 8 volts. Go to Section D on Page 37.	251/04	3597/04
6	3	Excessive power line resistance	Power Supply DTC - possible corroded or shorted trailer power circuit. Go to Section D on Page 37.	251/13	3597/13
Pressure Sensors (Internal): "P4", "P42", & "P21", "P22" & "P1"					
7	1	Internal Pressure Sensor Range: Control Port "P4"	<ul style="list-style-type: none"> • Verify the trailer's control (service) pressure is < 130 psi. • After repairs — or if no issues are found — clear the diagnostic code. • If the diagnostic code persists, contact your local Bendix representative before replacing the Bendix® TABS-6™ Adv MC module. 	077/12	1067/12
7	2	Internal Pressure Sensor Range: Load Port "P42"	<ul style="list-style-type: none"> • See the suspension manufacturer's specifications for load versus pressure. Verify that the trailer's air suspension pressure is <130 psi and is within the allowable range for the specific suspension/airbag combination. [below 50% of airbag pressure at the unladen weight, or above 50% of airbag pressure at GVWR for axles] • After repairs — or if no issues are found — clear the diagnostic code. • If the diagnostic code persists, contact the BCVS local representative before replacing the TABS-6 Adv MC module. 	069/12	1059/12
7	3	Internal Pressure Sensor Range: Delivery Port "P21"	<ul style="list-style-type: none"> • Perform a Pressure Component Test using the Bendix® ACom® diagnostic software (version 6.1 or higher). • Verify the trailer's control (service) and brake delivery pressures are comparable and < 130 psi. 	059/12	1049/12
7	4	Internal Pressure Sensor Range: Delivery Port "P22"	<ul style="list-style-type: none"> • After repairs — or if no issues are found — clear the diagnostic code. • If the diagnostic code persists, contact your local Bendix representative before replacing the TABS-6 Adv MC module. 	062/12	1052/12
7	5	Internal Pressure Sensor Range: Supply Port "P1"	<ul style="list-style-type: none"> • Verify the trailer's service reservoir pressure is < 123 psi (8.5 bar). • After repairs — or if no issues are found — clear the diagnostic code. • If the diagnostic code persists, contact your local Bendix representative before replacing the TABS-6 Adv MC module. 	151/12	1086/12
Lateral Acceleration Sensor					
8	1	Lateral Acceleration Sensor - Signal Mounting Error	<ul style="list-style-type: none"> • Before troubleshooting, verify that the trailer has been parked on level ground. • Verify that the TABS-6 Advanced MC ECU has been programmed with the proper ECU orientation, tire size and tone ring settings. • Verify that the TABS-6 Advanced MC module has been mounted as per the Installation Guidelines: <ul style="list-style-type: none"> - The configured ECU orientation matches the actual ECU orientation. - Verify that all wheel speed sensors are installed correctly (correct axle/left/right) (<i>See Figure 19</i>) • After repairs or if no issues are found, then clear the diagnostic codes. • If diagnostic code persists, contact the BCVS local representative before replacing the TABS-6 Advanced MC module. 	099/14	1809/14

Diagnostic Trouble Codes (DTCs) (continued)

1st Digit	2nd Digit	Diagnostic Code Description	Possible Causes / Repair Information	J1587 (SID/FMI)	J1939 (SPN/FMI)
8	2	Lateral Acceleration Sensor - Signal Out Of Range	<ul style="list-style-type: none"> • Before troubleshooting, verify that the trailer has been parked on level ground. • Verify that the TABS-6 Adv MC module has been mounted as per the Installation Guidelines. • Perform a Lateral Acceleration Sensor (installation angle) Component Test using the Bendix® ACom® diagnostic software (version 6.1 or higher), and verify that the roll angle of the TABS-6 Adv MC module is within $\pm 5^\circ$ as measured from a flat horizontal plane. • After repairs — or if no issues are found — clear the diagnostic code. • If the diagnostic code persists, contact your local Bendix representative before replacing the TABS-6 Adv MC module. 	099/14	1809/14
8	3	Internal Lateral Acceleration Sensor - Offset Error	<ul style="list-style-type: none"> • Before troubleshooting, verify that the trailer has been parked on level ground. • Verify that the TABS-6 Adv MC module has been mounted as per the Installation Guidelines. • Perform a Lateral Acceleration Sensor (installation angle) Component Test using the Bendix® ACom® diagnostic software (version 6.1 or higher). <ul style="list-style-type: none"> – Verify the roll angle of the TABS-6 Adv MC module is within $\pm 5^\circ$ as measured from a flat horizontal plane. – If the roll angle is out of tolerance, clear the diagnostic code and test drive the vehicle. • After repairs — or if no issues are found — clear the diagnostic code. • If the diagnostic code persists, contact your local Bendix representative before replacing the TABS-6 Adv MC module. 	099/02	1809/02
8	4	Lateral Acceleration Sensor - Sensor Signal Not Found	<ul style="list-style-type: none"> • Verify that the TABS-6 Adv MC module has been mounted as per the Installation Guidelines: <ul style="list-style-type: none"> – TABS-6 Adv MC module mounted either in 0° or 180° orientation. • If the ECU has been configured for an external lateral acceleration sensor: <ul style="list-style-type: none"> – Check for corroded/damaged wiring or connectors between the ECU and the external lateral acceleration sensor. – Verify correct wiring between the ECU and the external lateral acceleration sensor. 	099/14	1809/14
8	5	External Lateral Acceleration Sensor Signal Not Available	<ul style="list-style-type: none"> • Check for corroded/damaged wiring or connectors between the ECU and the external lateral acceleration sensor. • Verify correct wiring between the ECU and the external lateral acceleration sensor. • After repairs — or if no issues are found — clear the diagnostic code. • If the diagnostic code persists, contact your local Bendix representative before replacing the Bendix® TABS-6™ Adv MC module. 	099/14	1809/14

Diagnostic Trouble Codes (DTCs) (continued)

1st Digit	2nd Digit	Diagnostic Code Description	Possible Causes / Repair Information	J1587 (SID/ FMI)	J1939 (SPN/ FMI)
Trailer System Braking					
9	1	Valve Plausibility Error - Extended Brake Application	<ul style="list-style-type: none"> • Verify that there is no residual pressure in the trailer's control (service) line. • After repairs — or if no issues are found — clear the diagnostic code. • If the diagnostic code persists, contact your local Bendix representative before replacing the TABS-6 Adv MC module. 	057/07	1047/07
9	2	ABS Plausibility Error - Excessive ABS Activity	<ul style="list-style-type: none"> • Check for corroded/damaged wiring or connectors between the ECU and the WSS. • Check the air gap between the sensor and tone ring, pushing-in sensor(s) if needed. • Rotate the wheel and verify a min. of 0.25 VAC sensor output @ ~ 0.5 RPS. • Verify the condition of the sensor head. • Verify the condition and retention power of the clamping sleeve. • Verify the proper mounting of the exciter ring and condition of the teeth. • Check the wheel bearings for correct adjustment. • Verify the sensor wire routing and clamping. • After repairs — or if no issues are found — clear the diagnostic code. • If the diagnostic code persists, contact your local Bendix representative before replacing the TABS-6 Adv MC module. 	057/07	1047/07
9	3	TRSP Plausibility Error - Excessive TRSP Activity	<ul style="list-style-type: none"> • Clear the diagnostic codes. • If the diagnostic code persists, contact your local Bendix representative before replacing the TABS-6 Adv MC module. 	057/07	1047/07

Diagnostic Trouble Codes (DTCs) (continued)

1st Digit	2nd Digit	Diagnostic Code Description	Possible Causes / Repair Information	J1587 (SID/FMI)	J1939 (SPN/FMI)
TABS-6 Adv MC module					
10	1	TABS-6 Adv MC Internal Error	<ul style="list-style-type: none"> • Check for damaged or corroded connectors. • Check for damaged wiring. • After repairs — or if no issues are found — clear the diagnostic code. • If the diagnostic code persists, contact your local Bendix representative before replacing the Bendix® TABS-6™ Adv MC module. 	254/12	629/12
10	2	TABS-6 Adv MC Configuration Error	<ul style="list-style-type: none"> • Verify the ECU parameters and actual system installation are compatible using the Bendix® ACom® diagnostic software (version 6.1 or higher). • Re-program the ECU as necessary. • If necessary, contact your local Bendix representative to obtain the correct configuration data. 	254/13	629/13
10	3	TABS-6 Adv MC EEPROM Error	<ul style="list-style-type: none"> • Verify the ECU parameters and actual system installation are compatible using the Bendix® ACom® diagnostic software (version 6.1 or higher). • Re-program the ECU as necessary. • If necessary, contact your local Bendix representative to obtain the correct configuration data. 	254/13	629/13
10	4	TABS-6 Adv MC Not Configured	<ul style="list-style-type: none"> • Re-program the ECU to be compatible to the actual system configuration using the Bendix® ACom® diagnostic software (version 6.1 or higher). • If necessary, contact your local Bendix representative to obtain the correct configuration data. 	254/13	629/13
10	5	TABS-6 Adv MC EOL Test Not Completed	<ul style="list-style-type: none"> • Perform the Installation Test using the Bendix® ACom® diagnostic software (version 6.1 or higher), or Bendix® Trailer Information Module. 	254/14	629/14

Diagnostic Trouble Codes (DTCs) (continued)

1st Digit	2nd Digit	Diagnostic Code Description	Possible Causes / Repair Information	J1587 (SID/ FMI)	J1939 (SPN/ FMI)
Auxiliary Design Language (ADL) & Auxiliary I/Os					
11	1	Auxiliary I/O Error – AUX WL (#7)	<ul style="list-style-type: none"> • Check for corroded/damaged wiring or connectors between the ECU and ABS Indicator Lamp. • Check pin X1-5 of the ECU 'Power' connector for the following: <ul style="list-style-type: none"> – Pin not pushed back. – Correctly wired to the ABS Indicator Lamp (Pin X1-5 – supply) – Shorted to ground, V_{bat} or other ECU pins. • Verify the ABS Indicator Lamp is properly grounded and not burnt out. • After repairs — or if no issues are found — clear the diagnostic code. • If the diagnostic code persists, contact your local Bendix representative before replacing the TABS-6 Adv MC module. 	152/12	612/12
11	2	Auxiliary I/O Error – AUX I/O #1	<ul style="list-style-type: none"> • Check for corroded/damaged wiring or connectors between the ECU and the auxiliary device. • Check Pins X2-1 & X2-11 of the ECU 'In-Out' (I/O) connector for the following: <ul style="list-style-type: none"> – Pins not pushed back. – Correctly wired to the auxiliary device (Pin X2-1 – supply, pin X2-11 – ground) – Shorted to ground, V_{bat} or other ECU pins. • Verify the auxiliary device is properly functioning and rated for maximum load of ≤ 2 amps. • After repairs — or if no issues are found — clear the diagnostic code. • If the diagnostic code persists, contact your local Bendix representative before replacing the Bendix® TABS-6™ Adv MC module. 	152/12	612/12
11	3	Auxiliary I/O Error – AUX I/O #2	<ul style="list-style-type: none"> • Check for corroded/damaged wiring or connectors between the ECU and the auxiliary device. • Check Pins X2-2 & X2-11 of the ECU 'In-Out' connector for the following: <ul style="list-style-type: none"> – Pins not pushed back. – Correctly wired to the auxiliary device (Pin X2-2 – supply, Pin X2-11 – ground) – Shorted to ground, V_{bat} or other ECU pins. • Verify the auxiliary device is properly functioning and rated for maximum load of ≤ 2 amps. • After repairs — or if no issues are found — clear the diagnostic code. • If the diagnostic code persists, contact your local Bendix representative before replacing the TABS-6 Adv MC module. 	152/12	612/12
11	6	Auxiliary I/O Error – AUX I/O #3	<ul style="list-style-type: none"> • Check for corroded/damaged wiring or connectors between the ECU and the auxiliary device. • Check Pins X2-3 & X2-12 of the ECU 'In-Out' connector for the following: <ul style="list-style-type: none"> – Pins not pushed back. – Correctly wired to the auxiliary device (Pin X2-3 – supply, pin X2-12 – ground) – Shorted to ground, V_{bat} or other ECU pins. • Verify the auxiliary device is properly functioning and rated for maximum load of ≤ 1.5 amps. • After repairs — or if no issues are found — clear the diagnostic code. • If the diagnostic code persists, contact your local Bendix representative before replacing the TABS-6 Adv MC module. 	152/12	612/12

Diagnostic Trouble Codes (DTCs) (continued)

1st Digit	2nd Digit	Diagnostic Code Description	Possible Causes / Repair Information	J1587 (SID/FMI)	J1939 (SPN/FMI)
11	8	Auxiliary Electrical Error #4	<ul style="list-style-type: none"> • Clear diagnostic codes. • If the diagnostic code persists, contact your local Bendix representative before replacing the TABS-6 Adv MC module. 	152/12	612/12
11	9	Auxiliary Program Error – ADL	<ul style="list-style-type: none"> • Verify that the Auxiliary I/O ECU pin-outs match the ADL parameters using the Bendix® ACom® diagnostic software (version 6.1 or higher). • If necessary, contact your local Bendix representative to troubleshoot the ADL program. 	152/12	612/12
11	10	Low Supply Pressure	<ul style="list-style-type: none"> • Check if the trailer's service reservoir pressure is < 75 psi (5.2 bar). • If the trailer's service reservoir pressure is > 75 psi (5.2 bar): – Cycle Ignition power “OFF” and “ON”. • If the diagnostic code persists, contact your local Bendix representative before replacing the Bendix® TABS-6™ Adv MC module. 	152/01	612/01
11	11	WL (Indicator Lamp) Information – ADL	<ul style="list-style-type: none"> • Verify that the ADL parameters are correct using the Bendix® ACom® diagnostic software (version 6.1 or higher). • If necessary, contact your local Bendix representative to troubleshoot the ADL program. 	152/14	612/14
Miscellaneous					
12	1	Service Distance or Date Exceeded	<ul style="list-style-type: none"> • Perform scheduled trailer maintenance and/or reset the Service Distance or Date. • Perform the Installation Test using the Bendix ACom diagnostic software (version 6.1 or higher), or Bendix® Trailer Information Module. 	153/00	612/00
12	2	Trailer Load Out of Range	<ul style="list-style-type: none"> • If trailer is equipped with a raise/lower valve, verify it is in the drive position. • Verify that the ECU parameters for the empty and fully loaded trailer conditions are correct using the Bendix ACom diagnostic software (version 6.1 or higher), or Bendix Trailer Information Module. • If necessary, contact your local Bendix representative to troubleshoot the trailer's loading condition. 	069/13	1059/13
12	3	Brake Pads Worn	<ul style="list-style-type: none"> • Manually check the condition of the pads on each brake to determine if any require replacement. • If no pads require replacement, check the wear sensors and cables for damage or defects. 	070/01	1060/01
12	4	Low System Pressure, P1	<ul style="list-style-type: none"> • Check if the trailer's service reservoir pressure is < 65 psi (4.5 bar). • If the trailer's service reservoir pressure is > 65 psi (4.5 bar): – Cycle Ignition power “OFF” and “ON”. • If the diagnostic code persists, contact your local Bendix representative before replacing the TABS-6 Adv MC module. 	254/11	1086/11
12	8	Trailer Information Module Missing	<ul style="list-style-type: none"> • Trailer Information Module and/or harness damaged or not present. 	254/11	0/11
Mechanical Load Sensor					
13	4	Load Sensor Error	<ul style="list-style-type: none"> • (Spring Suspension Systems) Inspect the linkage: Check that the linkage is attached to the axle, inspect for damage to the linkage components, loose connectors and mis-installation. • If the diagnostic code persists, contact your local Bendix representative before replacing the TABS-6 Adv MC module. 	69/13	0/13

Troubleshooting

USING HAND-HELD OR PC-BASED DIAGNOSTICS

Troubleshooting and Diagnostic Trouble Code (DTC) clearing, as well as beginning a reconfiguration, may also be carried out using hand-held or PC-based diagnostic tools such as the Bendix® Trailer Remote Diagnostic Unit (TRDU™), Bendix® ACom® diagnostics software, or the Bendix® Trailer Information Module.

23. BENDIX ABS DIAGNOSTIC TOOLS

ACom Diagnostic Software

ACom diagnostic software (version 6.1 or higher) is an RP-1210 compliant PC-based diagnostic software program that provides the highest level of diagnostic support for the Bendix® TABS-6™ Adv MC module. With Bendix ACom diagnostic software, maintenance personnel can:

- Obtain DTC information (both active and inactive DTCs)
- Retrieve event history
- Clear inactive DTCs and event history
- Verify ECU configuration
- Perform system and component tests
- Read/write customer information in the scratch pad
- Save and print information
- Receive troubleshooting assistance

When diagnosing the Bendix TABS-6 Adv MC module using a PC and ACom diagnostic software, the computer's serial or parallel port can be connected to the vehicle's diagnostic connector through an RP-1210 compliant communications device.

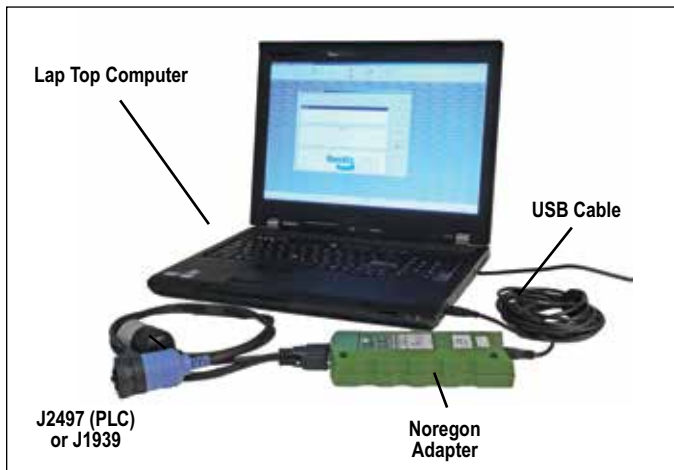

FIGURE 10 - LAP TOP COMPUTER WITH BENDIX® ACOM® DIAGNOSTIC SOFTWARE

For more information on the ACom diagnostic software, or RP-1210 compliant tools, contact Bendix or refer to your local authorized Bendix parts outlet.

Bendix® Trailer Remote Diagnostic Unit (TRDU™) Tool (802162)



FIGURE 11 - THE BENDIX® TRDU™

The Bendix® TRDU™ tool provides the technician with a visual indication of Antilock Braking System (ABS) component DTC information. The TRDU tool is specifically designed for use with Bendix® Trailer ABS systems and Bendix makes no claims for its operation and/or usability with other brands of trailer ABS.

Features of the Bendix TRDU Tool

The TRDU tool attaches to a 7-pin-to-7-pin adapter (See Figure 12) and then into the J560 connector of the towing vehicle.



FIGURE 12 - TRDU™ TOOL AND ADAPTER

The TRDU tool communicates across PLC.

The TRDU tool allows the technician to:

- Troubleshoot ABS system component problems using DTC reporting via LEDs.
- Reset DTCs on Bendix® ABS ECUs by holding a magnet over the reset of the TRDU tool for less than 6 seconds.

How the Bendix® TRDU™ Tool Operates

When the TRDU tool is plugged into the adapter — and the adapter/TRDU tool is installed between the trailer connector and the J560 connector of the towing vehicle that has the ignition on — all the LEDs will illuminate, and the green LED will flash 4 times to indicate communications have been established.

If the ABS ECU has no active Diagnostic Trouble Codes (DTCs), only the green LED will remain illuminated.

If the ABS ECU has at least one active DTC the TRDU tool displays the first DTC by illuminating the red LEDs, indicating the malfunctioning ABS component and its location on the vehicle. (See Figure 13.)

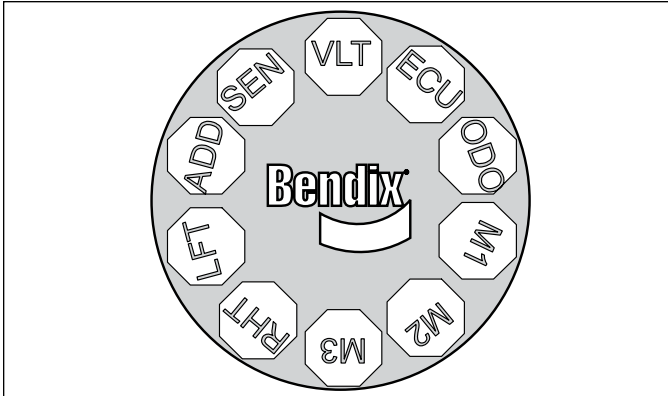

FIGURE 13 - THE BENDIX® TRDU™ TOOL DISPLAY

LED Diagnostic Trouble Codes			
VLT -	Power	MOD3 -	Modulator 3
ECU -	ABS Controller	LFT -	Left
SEN -	Wheel Speed Sensor	RHT -	Right
MOD1 -	Modulator 1	ADD -	Additional
MOD2 -	Modulator 2	ODO -	Odometer

Example: If the DTC is "Right Additional Sensor", the TRDU™ tool will display one green and three red LEDs

LEDs
Green
VLT
Blue
ODO
All others are Red

FIGURE 14 - DIAGNOSTIC TROUBLE CODES USING THE BENDIX® TRDU™ TOOL

If there are multiple DTCs on the ABS system, the TRDU tool will display one DTC first, then once that DTC has been repaired and cleared, the next code will be displayed. The TRDU tool repeatedly blinks out the mileage stored once communications have been established. By counting the sequence of blinks and/or strobes on the blue LED, the odometer reading is given. See Section 10 for more details.

- VLT (Flashing indicates either over- or under-voltage condition)

To pinpoint the root cause and to ensure the system DTC is properly corrected the first time, additional troubleshooting may be necessary.

Note: When a TRDU tool is connected to a system with a Bendix® TABS-6™ Adv MC module, and has established communications, the ECU will use the ABS indicator lamp to blink codes for all active DTCs.

Bendix TRDU Tool Reset Function

The magnetic reset switch is located by the letter "B" in the Bendix logo on the top of the TRDU tool. When a magnet (with minimum of 30 gauss) is held over the switch for less than 6 seconds the "clear DTCs" command is sent. (If a magnet is not available, you may use a spare wheel speed sensor, since its internal magnet will be sufficient.)

Additionally, it is recommended at the end of any inspection that the technician switches off and restores the power to the ABS ECU, and then re-checks the ABS indicator lamp and TRDU tool to see if they indicate any remaining DTCs.

Bendix® Trailer Information Module

The Bendix Trailer Information Module is a display device that combines the functionality of system diagnostics with the ability to display and store other trailer-related information of value to an operator, driver or workshop. Maximum benefit is obtained from the Trailer Information Module functionality when it is mounted on the trailer so that it is able to record events that occur during driving. Alternatively, it may also be used as a workshop tool to access diagnostic information or to check the configuration or run an installation test. In both cases the Trailer Information Module is connected to the J1939 EC5V TI (CAN) connection of the auxiliary connector which supplies the necessary information.



FIGURE 15 - TRAILER INFORMATION MODULE ADDITIONAL SUPPORT AT

www.bendix.com

For the latest information, and for free downloads of literature and the Bendix® ACom® diagnostics software, and its User Guide, visit the Bendix website at www.bendix.com.

Bendix Technical Assistance Team

For direct personal technical support, call the Bendix technical assistance team at **1-800-AIR-BRAKE** (1-800-247-2725), Monday through Friday, 8:00 a.m. to 6:00 p.m. EST.

Alternatively, you may e-mail the Bendix Tech Team at: techteam@bendix.com.

To better serve you, please record the following information before you call the Bendix Tech Team, or include this information in your e-mail:

- Bendix product model number, part number and configuration.
- Vehicle make and model.
- Vehicle configuration. (Number of axles, tire size, etc.)
- System performance symptoms: When do they occur?
- What DTCs have been identified using LEDs, blink codes or diagnostic tools?
- What troubleshooting/measurements have been performed?
- What Bendix service data literature do you have or need?

SERVICING THE BENDIX® TABS-6™ ADV MC MODULE

⚠ CAUTION: Special considerations need to be taken to ensure that the Bendix® TABS-6™ Adv MC module has been properly installed on the trailer. These include:

- Location and orientation of the module.
- Correct plumbing of the module.
- Correct deflection sensor installation (where used).
- Correct location of the wheel speed sensors.
- Configuration of the ECU for ABS & Bendix® TRSP® system parameters.
- Installation Test to verify proper installation of the ABS/TRSP system.

Incorrect installation of the TABS-6 Adv MC module system can result in impaired ABS & TRSP system functions. It is the responsibility of the end-user to ensure that the TABS-6 Adv MC module system has been installed correctly and tested as per the Bendix recommended installation guidelines and system drawings.

Prior to performing service to the TABS-6 Adv MC module, always perform the following steps:

1. Follow all industry safe maintenance practices including those on page 2 of this document.
2. Ideally, before removing the module, use Bendix® ACom® diagnostic software to save the configuration to the desktop. (After the module has been replaced, the technician can restore the previous configuration settings.)
3. Turn the power off.
4. Drain the air pressure from all reservoirs.
5. Remove as much contamination as possible prior to disconnecting electrical connections and air hoses.
6. Note the TABS-6 Adv MC module's mounting position on the vehicle.

REMOVING THE TABS-6 ADV MC MODULE

1. Open the end covers by sliding the locking tabs to the left. If the module is to be reinstalled, retain the covers.
2. Disconnect the 7-pin ECU connector, the 12-pin auxiliary/diagnostic harness (if present) and the two to four 2-pin wheel speed sensor connectors, depending on the configuration.
3. Mark for reinstallation and then remove all air hoses connected to the TABS-6 Adv MC module.
4. Remove the TABS-6 Adv MC module from the vehicle by removing the mounting fasteners.

SERVICING THE CONTROL PORT FILTER

⚠ CAUTION! The TABS-6 Advanced MC module has an in-line filter in the control port (See Figure 2). This filter should be inspected and cleaned (if any contamination is found), every four months, 34,000 miles or 1,200 operating hours. For severe applications, this inspection interval may be reduced. If the filter is found to be damaged, install a replacement. The filter should also be inspected as part of any troubleshooting where the service brakes are slow to apply and other possible causes have been ruled out.

REINSTALLATION OF THE BENDIX® TABS-6™ ADV MC MODULE

⚠ CAUTION! All service replacement parts for the Bendix® TABS-6™ Adv MC module are configured specifically by part number.

As mentioned during the *Servicing the Bendix TABS-6 Adv MC Module step*, ideally, before removing the module, use Bendix® ACom® diagnostic software to save the configuration to the desktop. The technician can use ACom diagnostics to restore the previous configuration settings.

Always verify that the correct service replacement ECU is being installed by verifying that the part number is the same as the original TABS-6 Adv MC module. To verify proper installation, perform the Installation Test using the Bendix ACom diagnostic software (version 6.1 or higher) or use the Bendix® Trailer Information Module.

Inspect the original mounting hardware: If it is in good condition, it can be reused for installation. If replacement hardware is needed, use Class 8 steel M10 x 1.5 nuts and lock washers for frame-mounting.

Inspect the location selected for installation and clean as necessary.

NOTE: Inspect all components, including the replacement TABS-6 Adv MC module, for any external damage, such as cracked valve ports, electronic housings, etc. Any components found to be damaged should not be installed on the vehicle and must be replaced.

1. The TABS-6 Adv MC module shall be installed with the following considerations (see Figures 16 through 18):

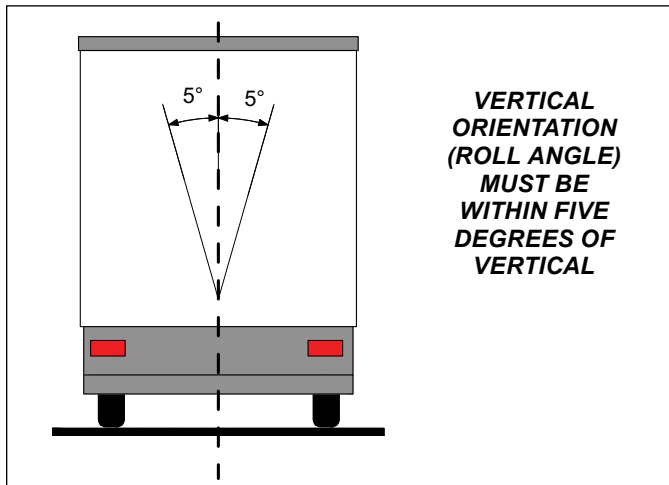

FIGURE 16 - INSTALLATION ON TRAILER (VERTICAL)

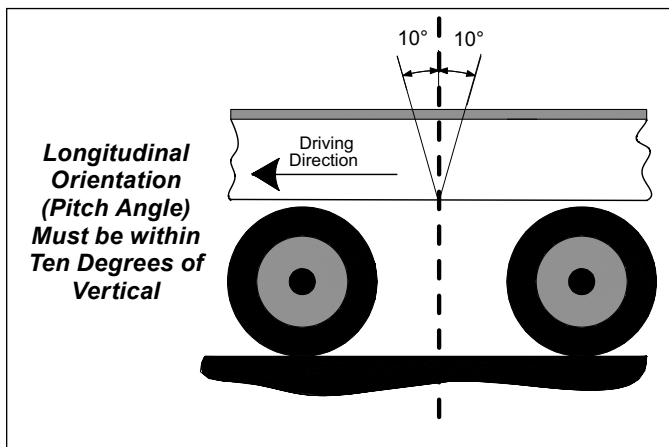

FIGURE 17 - INSTALLATION ON TRAILER (LONGITUDINAL)

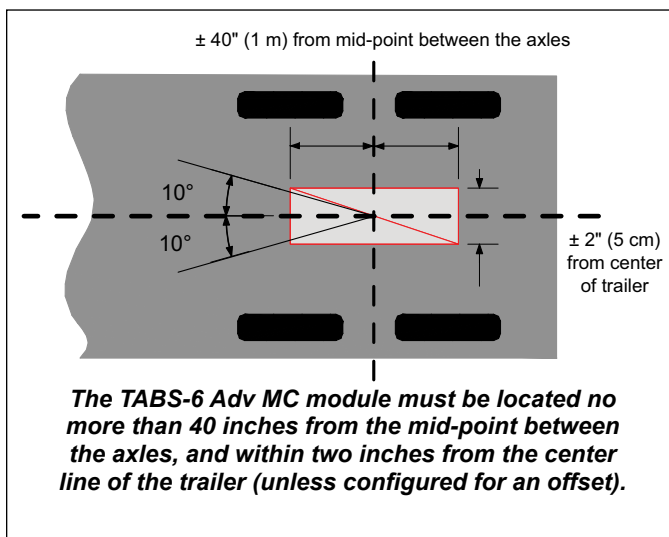

FIGURE 18 - INSTALLATION ON TRAILER (CENTER LINE)

- With exhaust port facing downward and unobstructed with significant free space below (> 1 inch).
- Within $\pm 40"$ of the center of the axle(s) for proper balanced brake applications.

- Within $\pm 2"$ from the center line of the trailer (default). Note, a left/right offset greater than $\pm 2"$ may have been programmed in the ECU and can be verified using Bendix ACom diagnostic software (version 6.1 or higher).
- Yaw angle shall be $\pm 10^\circ$ as measured from the center line of the trailer.
- Pitch angle shall be $\pm 10^\circ$ as measured from a flat horizontal plane.
- Roll angle shall be within $\pm 5^\circ$ as measured from a flat horizontal plane.

Frame-mount module: The TABS-6 Adv MC module uses three Class 8 steel M10x1.5 nuts with lock washers, torqued to 354 ± 44.4 in.-lbs (40 ± 5 Nm).

2. Reconnect all air hoses and plugs to the module. Depending on the installation, additional plugs may be necessary. Thread sealant products that contain Teflon may be used, however thread sealant tape is not recommended as there is a potential for tape material entering the valve and affecting the valve's operation. Make certain that no thread sealant enters the valve. All air hoses and fittings should be checked for leaks prior to returning the vehicle to service.

3. Reconnect the ECU power, auxiliary if present and wheel speed sensor electrical connectors to the ECU. Apply a moderate amount of non-conductive electrical grease to each connector pin before reconnecting.

Note: The wheel speed sensors must follow the orientation of the module as shown in Figure 19 for fixed axle trailers. Where a lift axle is present, and sensors are to be installed on that axle, secondary sensors SE and SF must be used for the lift axle.

- It is necessary to fix the wheel speed sensors to the orientation of the lateral acceleration sensor for plausibility checks between the sensors.
- If the wheel sensor location does not match the orientation of the Bendix® TABS-6™ Adv MC module shown in Figure 19, a Diagnostic Trouble Code (DTC) will be generated and the ABS indicator lamp will be illuminated.
- Refer to the raised lettering on the top cover for wheel speed designation, "S-C", "S-D", "S-E", and "S-F".

4. Leakage and Operational Tests must be performed before returning the vehicle to service.

LEAKAGE AND OPERATIONAL TESTS

1. Before performing the leakage tests, block the wheels.
2. Fully charge the air brake system and verify proper brake adjustment.
3. Make several trailer brake applications and check for prompt application and release at each wheel.

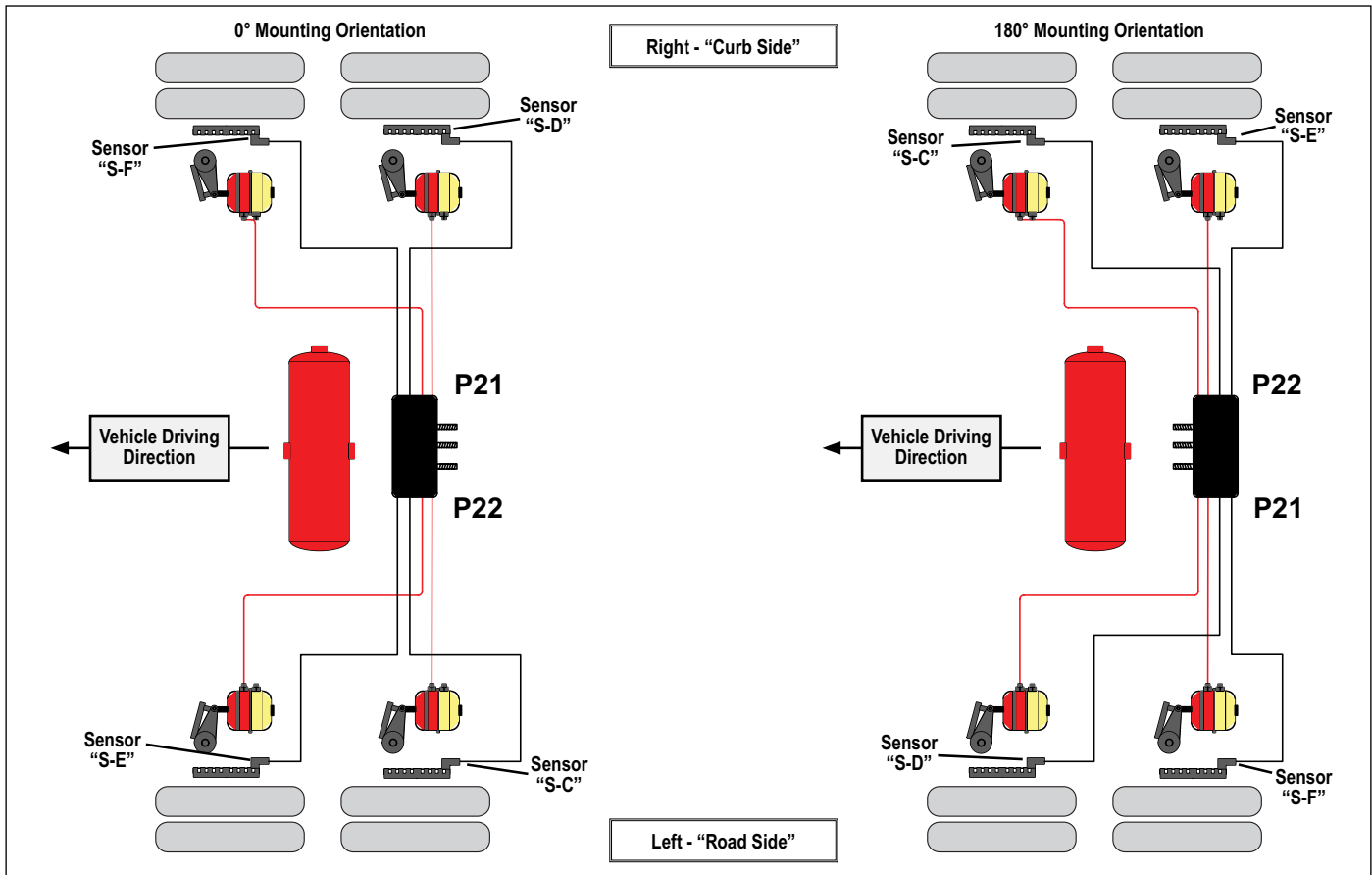

FIGURE 19 - WHEEL SPEED SENSOR INSTALLATION

4. Check the TABS-6 Adv MC module, modulator valve(s) and all air hose fittings for leakage using a soap solution.

Check the ABS solenoid body with the trailer service brakes fully applied. If leakage is excessive — more than a single 1" bubble within 1 minute — replace the TABS-6 Adv MC module.

Check the relay exhaust port with the trailer service brakes released to be sure that leakage is less than a single 1" bubble within 3 seconds. If excessive leakage is detected at the relay exhaust port, perform the following test before replacing the TABS-6 Adv MC module:

- Apply the trailer spring brakes. Recheck for leakage around the relay exhaust port. If the exhaust port stops leaking, this indicates a leak between the emergency and service sides of the spring brake chamber. However, if the relay exhaust port continues to leak excessively, replace the TABS-6 Adv MC module.

5. Apply power and monitor the power-up sequence to verify proper system operation. See Section 15.
6. Calibrate and set odometer parameters, if necessary, using a diagnostic tool. See Section 16.
7. Perform an installation test using a diagnostic tool. Minimum tests that are required to verify the proper installation of the ABS/TRSP system are:

- **ECU Information:** This test provides the user with specific ECU information. It is required that no DTC's (other than "end-of-line test not completed") are present and that the ECU has been configured.
- **Wheel End Sequence Test:** During this test, checks are carried out that verify the correlation of the wheel installed with a Wheel Speed Sensor and the Pressure Modulator that controls the pressure to the associated brake.
- **Lateral Acceleration Test:** The installation angle information is retrieved from the ECU and compared to the predefined limits (+/- 5 degrees). This test verifies that the unit is installed as close to horizontal as possible.
- **Pressure Sensor Test:** During this test, checks are carried out that verify that the proper response is received from the pressure sensors during a brake application.
- **Axle Load Sensing Test (Air Ride):** The test has the user verify the expected measurement of the load pressure sensor, Port 42, for air ride suspensions. The program provides the reading of the sensor.

- **Mechanical Load Sensor Test (Mechanical Spring Ride):** The test has the user verify the expected measurement of the spring deflection sensor. The program provides the reading of the sensor.
 - **Customer Scratch Pad:** The tester is requested to input data into the fields displayed on the screen. This data will be stored in the ECU and also can be stored to a file on the computer or printed out for reference.
8. Where a safe location (e.g. restricted access area or test track) is available, it is possible to road test the ABS function by making an abrupt stop from a vehicle speed of about 20 MPH to check for proper function. The wheels should not enter a prolonged lock condition and ABS function should be audible. It is the responsibility of the technician to perform this test in a safe location.

ABS WIRING

All connector leads of the Bendix® TABS-6™ Adv MC module pigtail harness are weather sealed at the connector interface and are clearly labeled for proper installation.

Bendix provides over-molded versions of the TABS-6 wiring harness and Bendix recommends that the complete harness be replaced if corrosion or damage occurs.

When troubleshooting ABS wiring, some general rules should be followed where applicable.

1. Check all wiring and connectors to ensure they are secure and free from visible damage (e.g. cuts, abrasions, etc.).
2. Check for evidence of wire chafing due to poor routing, or poor securing of wires.
3. Check connectors for proper insertion and locking.
4. Verify that the connector pins are properly greased with a non-conductive electrical grease compound.
5. Connector terminals must not show signs of corrosion or exposure to the environment.
6. Never pierce wire insulation when checking for continuity.
7. Do not deform individual pins or sockets during probing with a volt/ohm meter.
8. It is strongly recommended that all wiring harnesses and sensor leads are properly secured at least every 18 inches.
9. Apply a moderate amount of non-conductive electrical grease to each connector pin before reconnecting.

Troubleshooting: Electrical Schematics

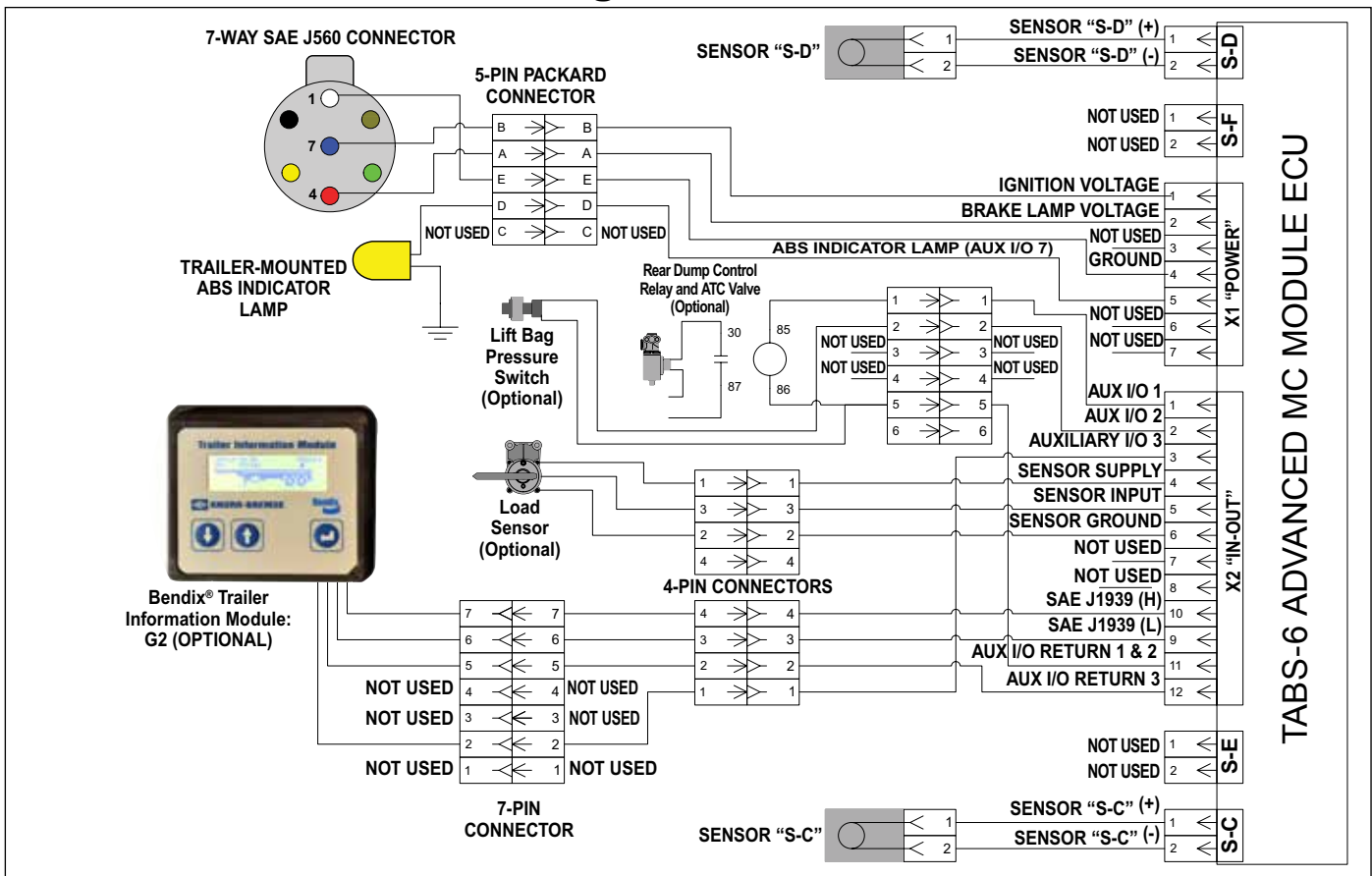

FIGURE 20 - BENDIX® TABS-6™ ADV MC MODULE ELECTRICAL SCHEMATIC - 2S/2M

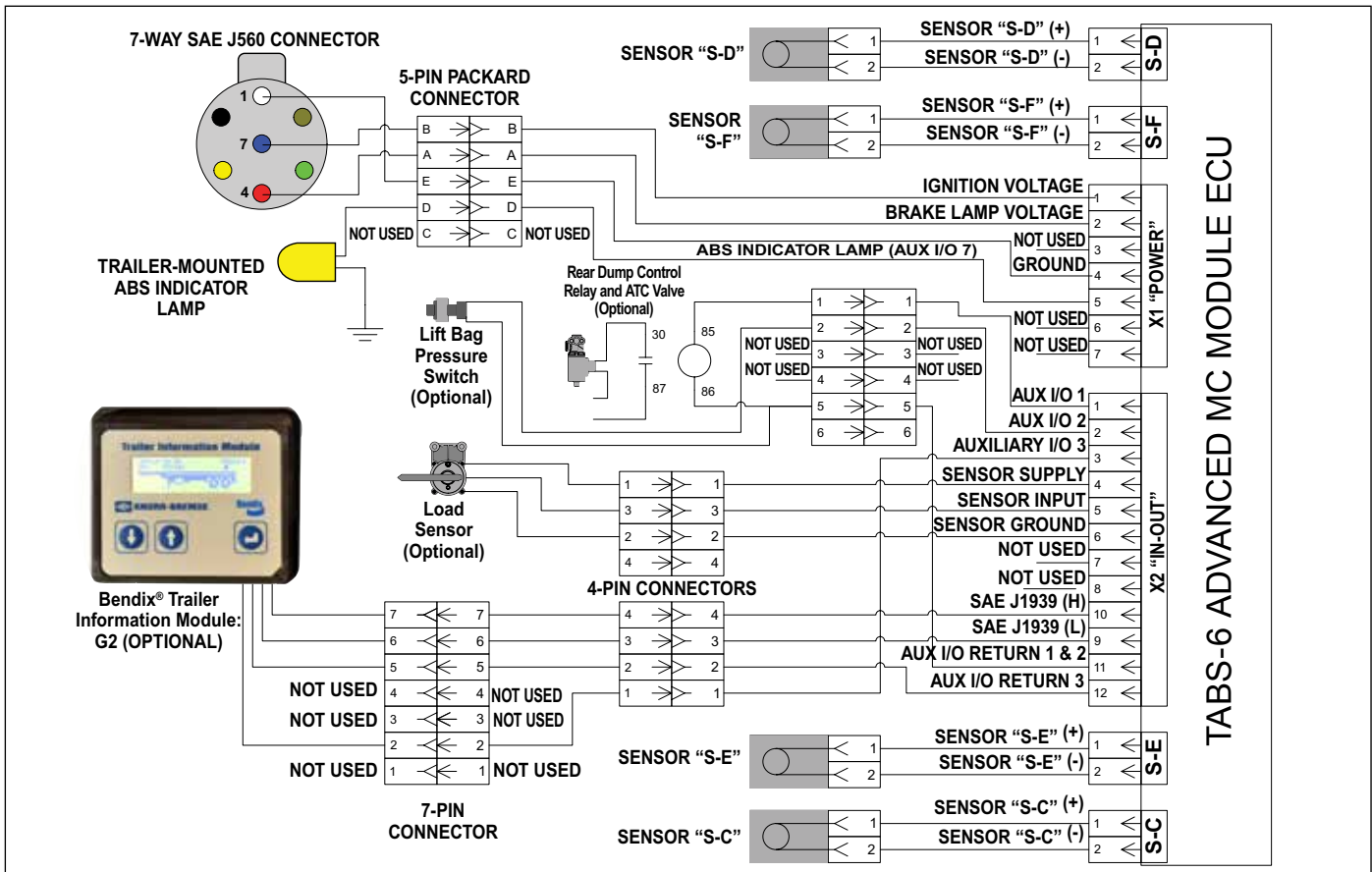

FIGURE 21 - BENDIX TABS-6 ADV MC MODULE ELECTRICAL SCHEMATIC - 4S/2M

Troubleshooting: System Schematics

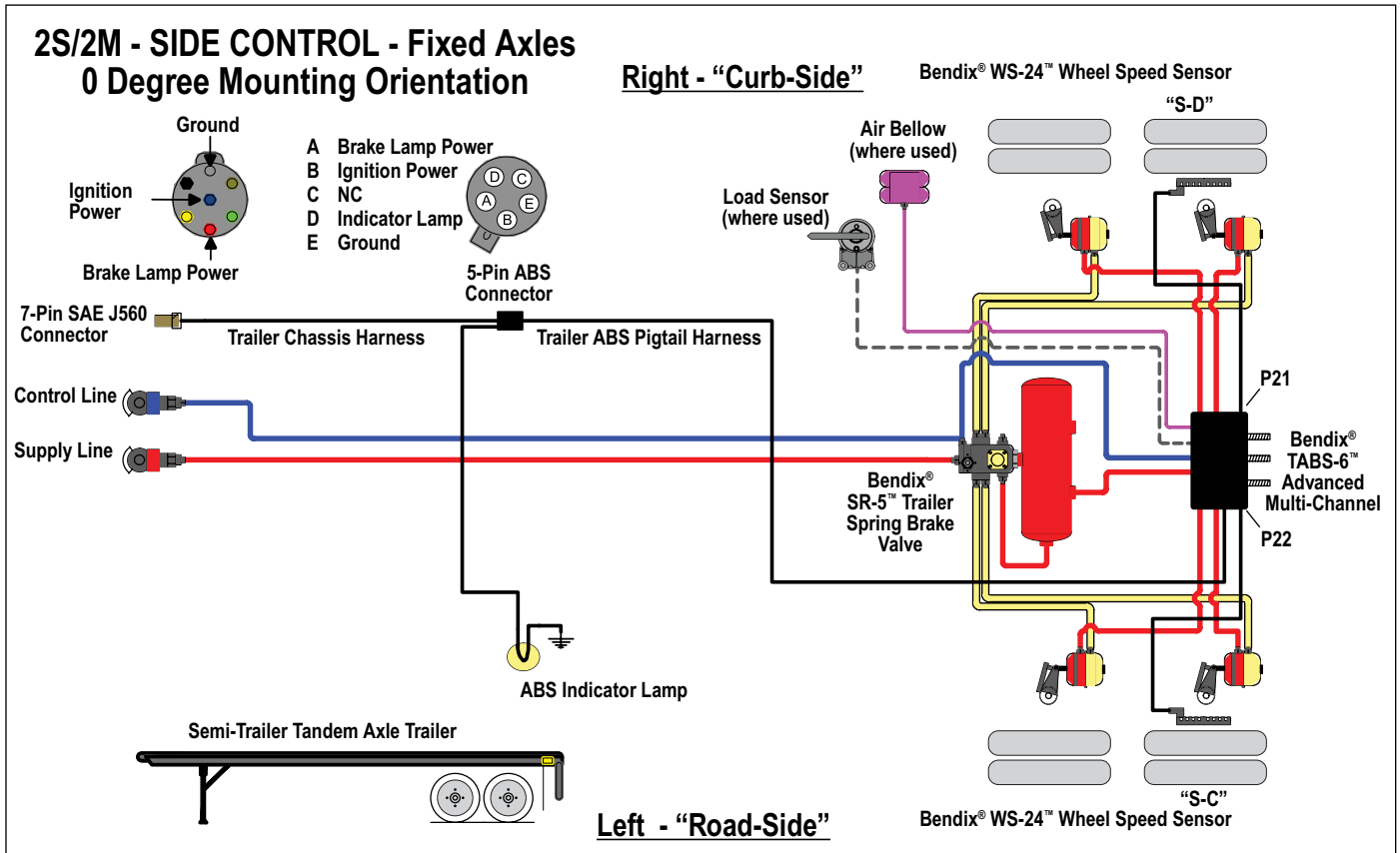

FIGURE 22 - BENDIX® TABS-6™ ADV MC MODULE - 2S/2M SIDE CONTROL (0 DEGREE) ABS ELECTRICAL & AIR SYSTEM

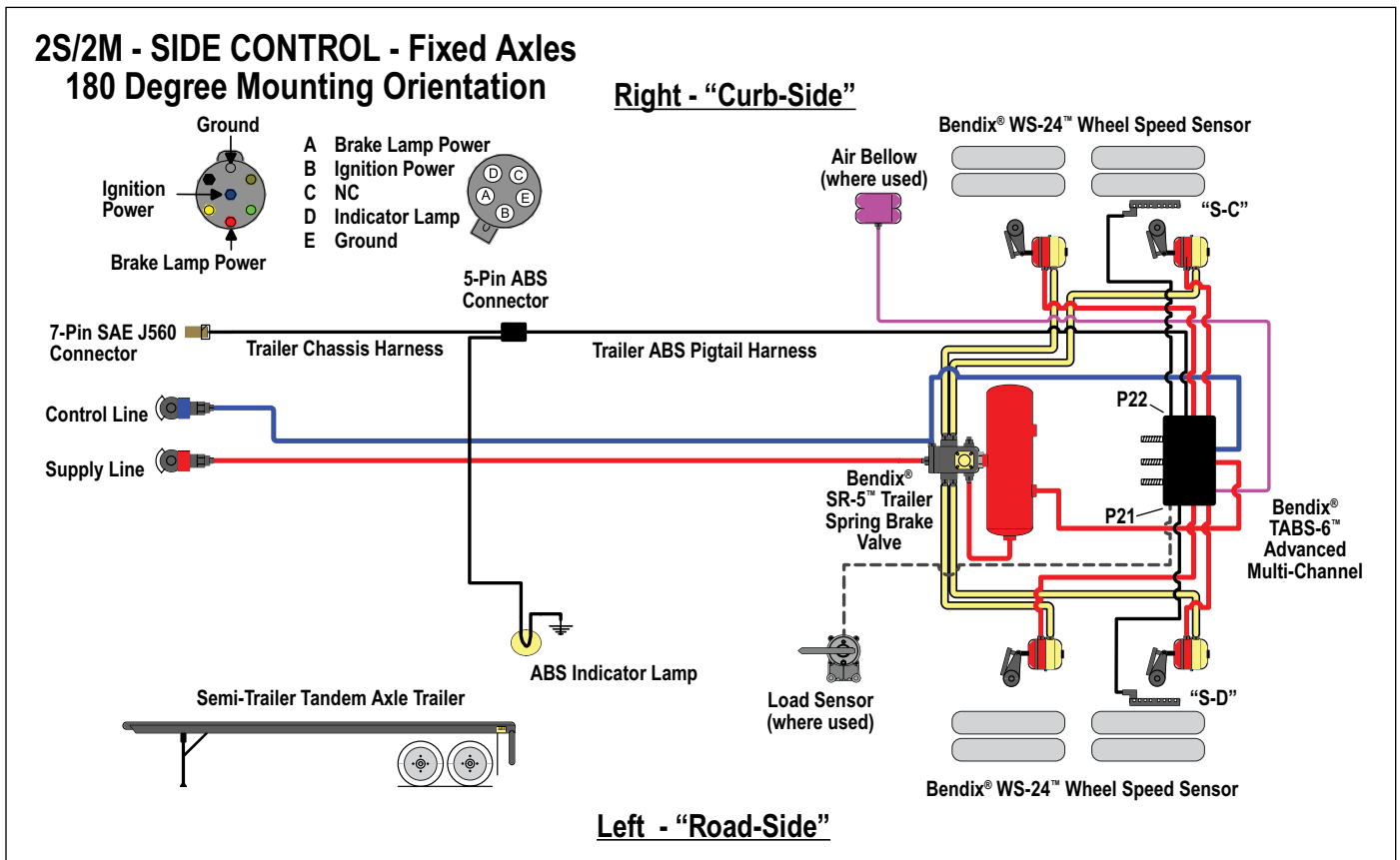

FIGURE 23 - BENDIX TABS-6 ADV MC MODULE - 2S/2M SIDE CONTROL (180 DEGREE) ABS ELECTRICAL & AIR SYSTEM

Troubleshooting: System Schematics

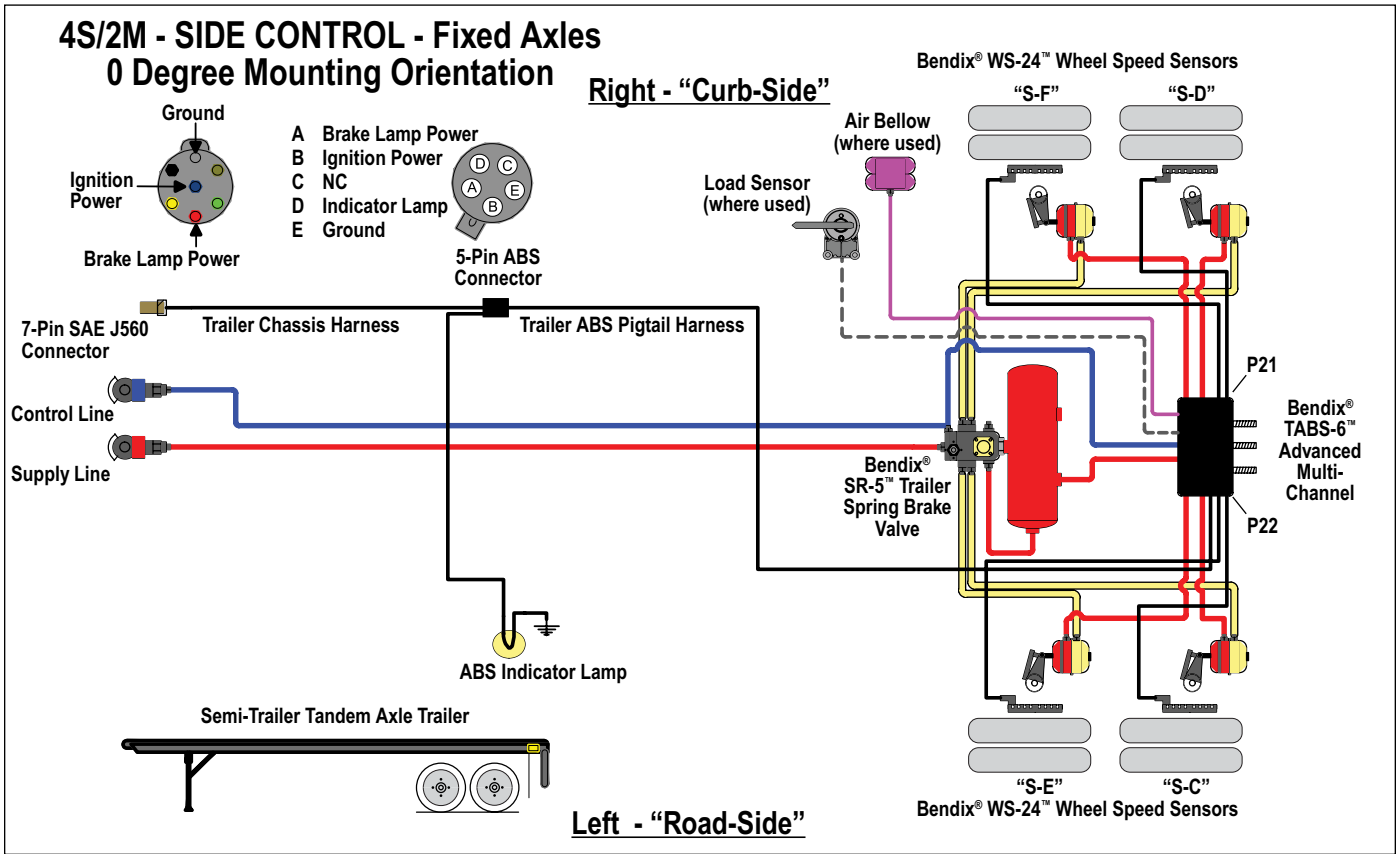

FIGURE 24 - BENDIX® TABS-6™ ADV MC MODULE - 4S/2M SIDE CONTROL (0 DEGREE) ABS ELECTRICAL & AIR SYSTEM

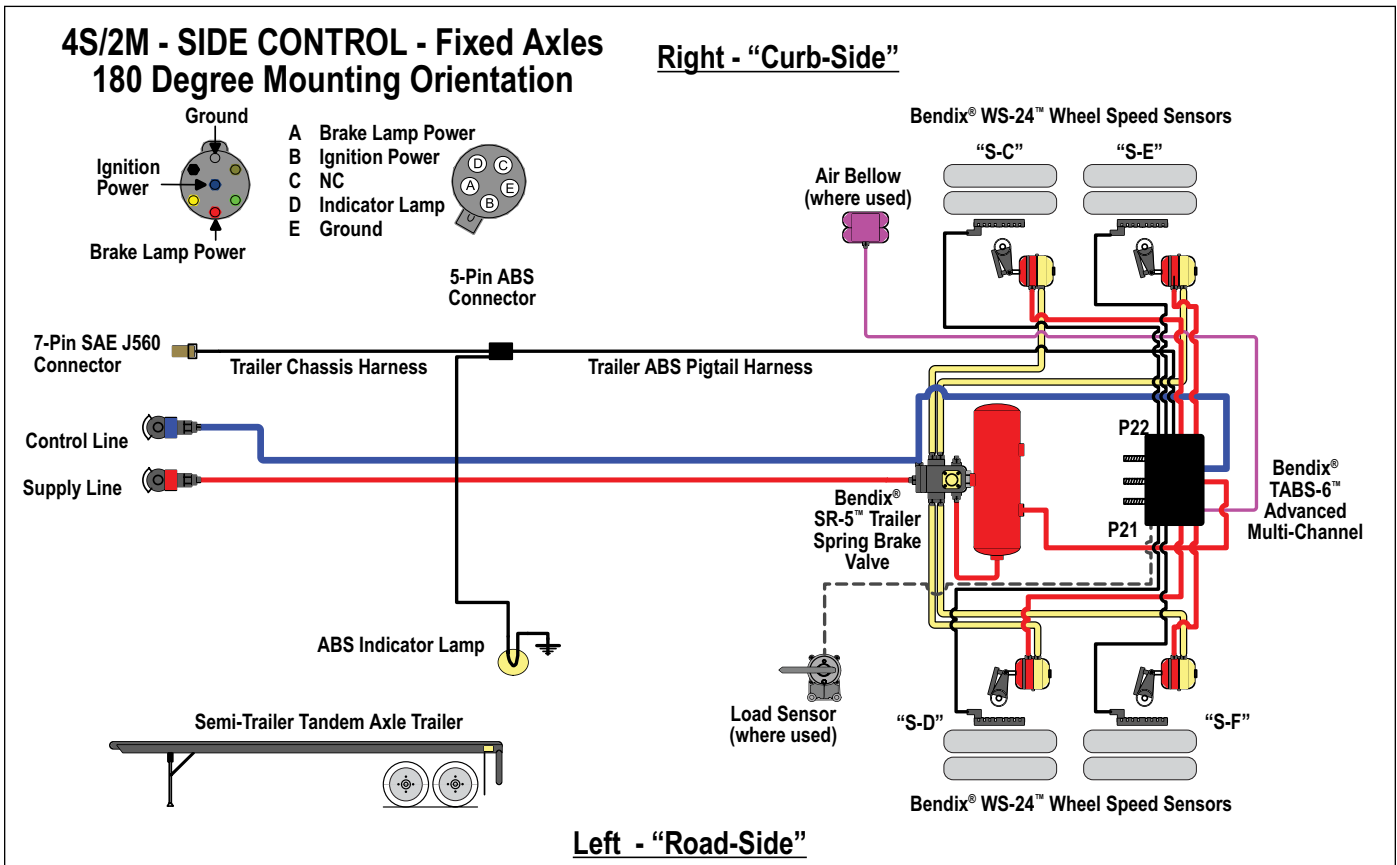

FIGURE 25 - BENDIX TABS-6 ADV MC MODULE- 4S/2M SIDE CONTROL (180 DEGREE) ABS ELECTRICAL & AIR SYSTEM

Troubleshooting: System Schematics

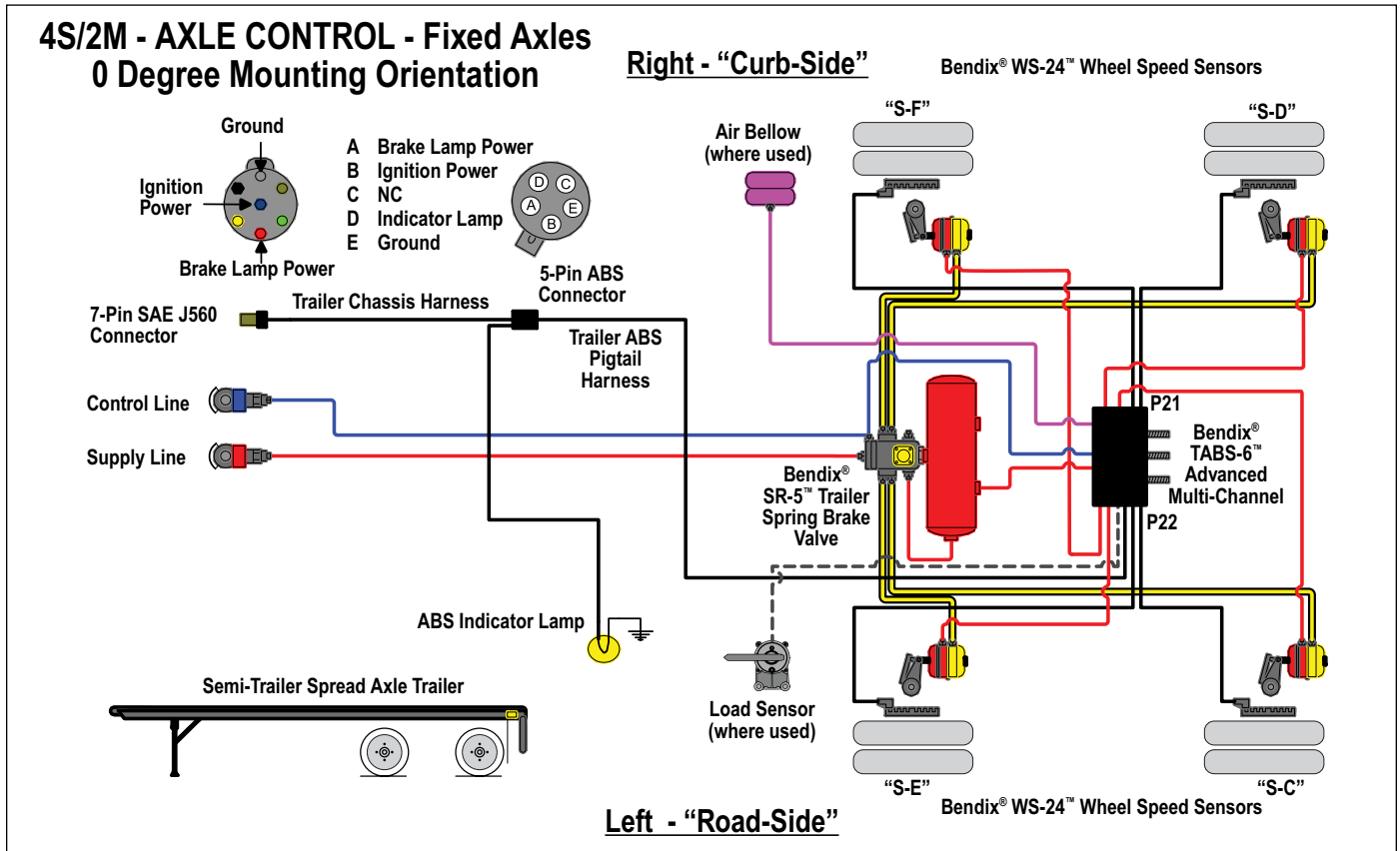

FIGURE 26 - BENDIX® TABS-6™ ADV MC MODULE - TYPICAL 4S/2M AXLE CONTROL ABS ELECTRICAL & AIR SYSTEM

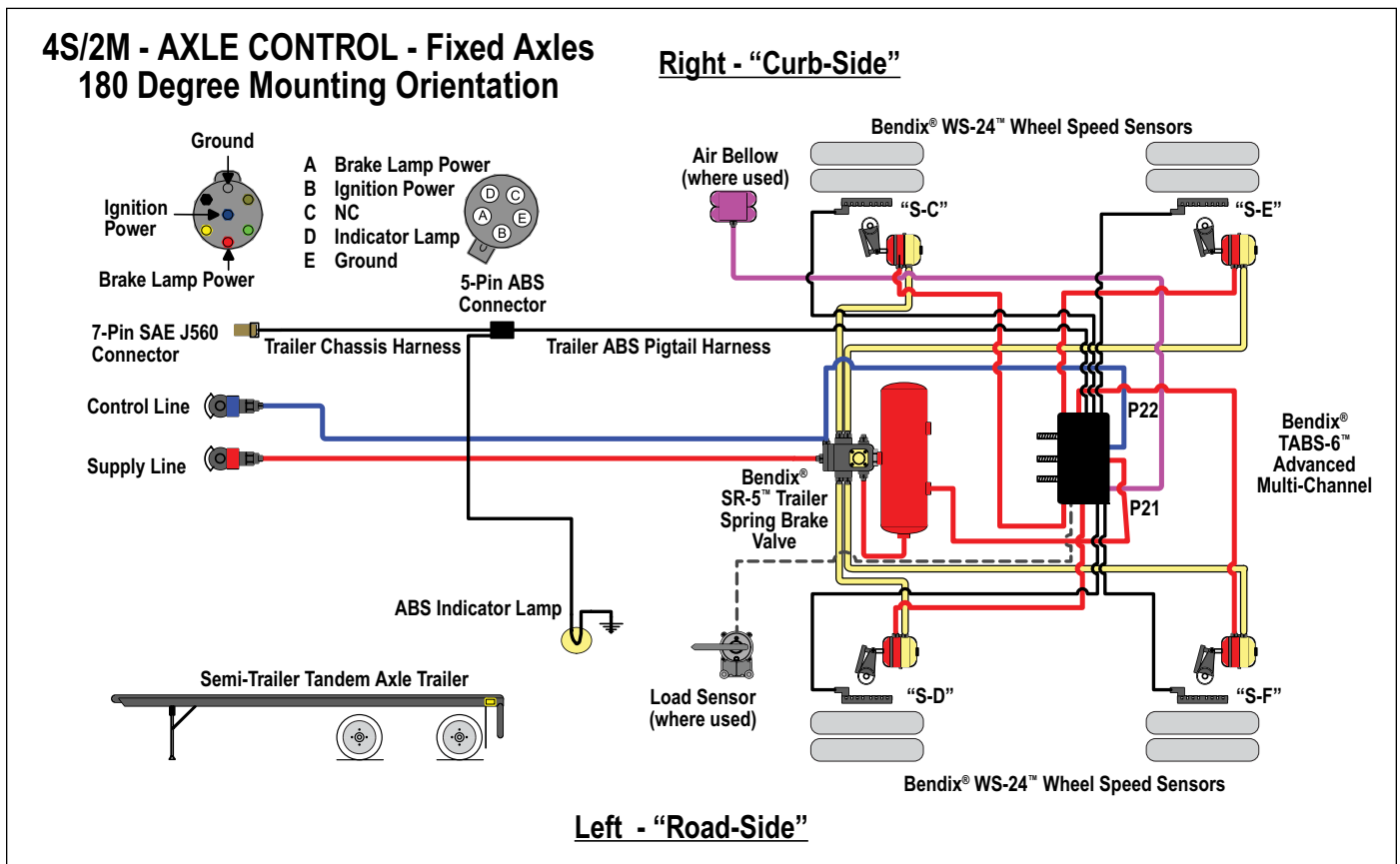

FIGURE 27 - BENDIX TABS-6 ADV MC MODULE - 4S/2M AXLE CONTROL (180 DEGREE) ABS ELECTRICAL & AIR SYSTEM

Troubleshooting: System Schematics

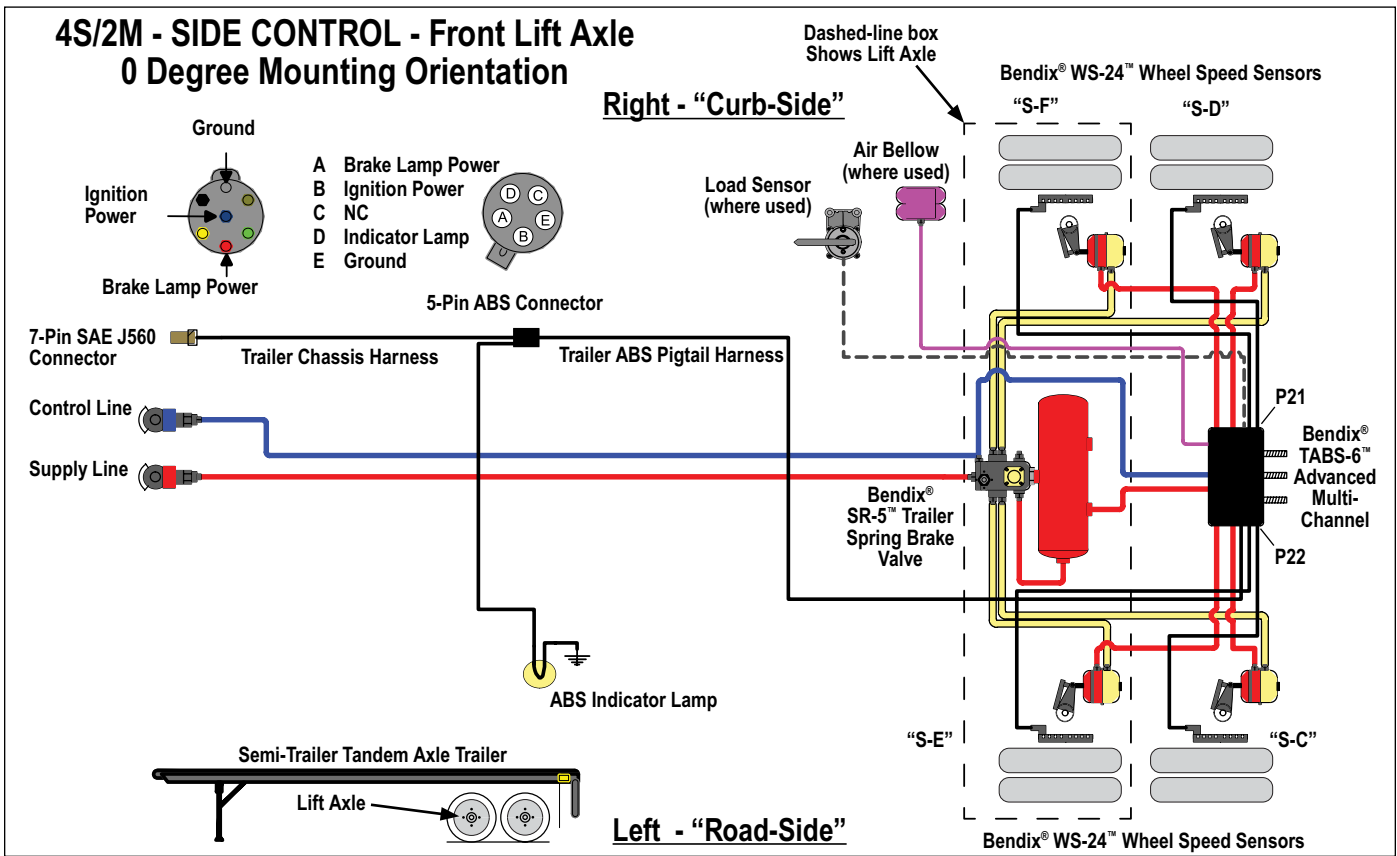

FIGURE 28 - 4S/2M SIDE CONTROL (0 DEGREE) WITH FRONT LIFT AXLE, ABS ELECTRICAL & AIR SYSTEM

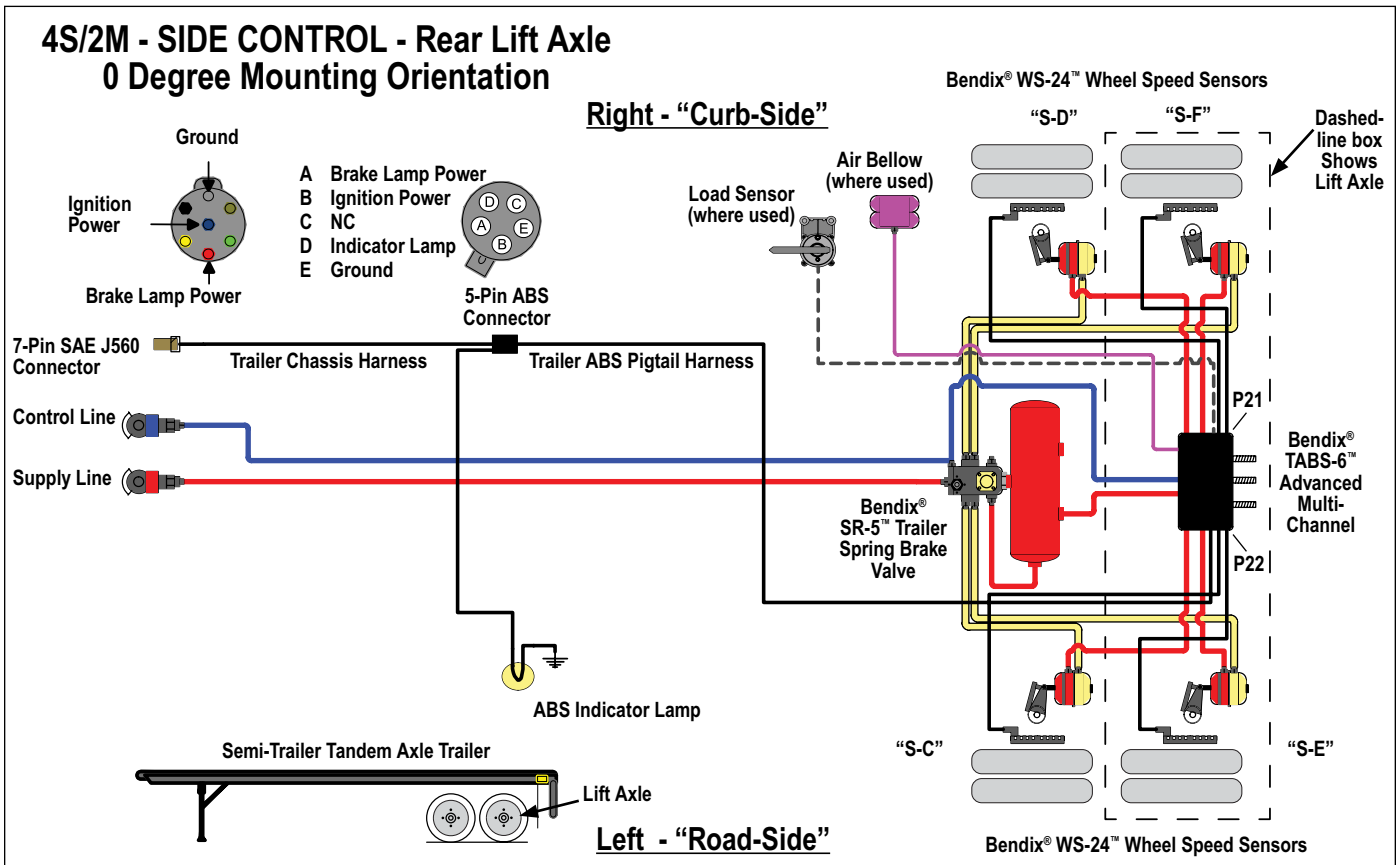

FIGURE 29 - 4S/2M SIDE CONTROL (0 DEGREE) WITH REAR LIFT AXLE, ABS ELECTRICAL & AIR SYSTEM

Troubleshooting: System Schematics

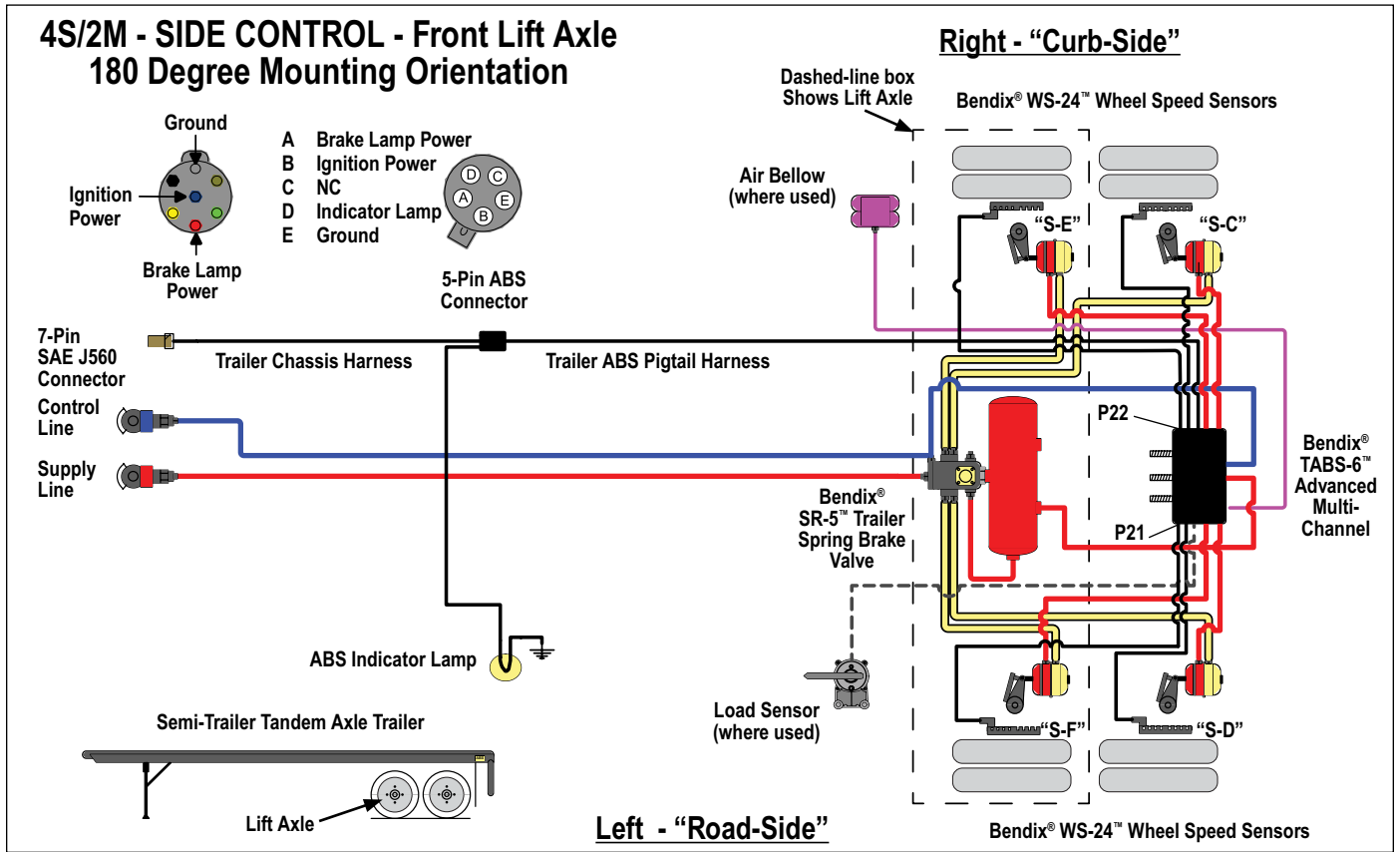

FIGURE 30 - 4S/2M SIDE CONTROL (180 DEGREE) WITH FRONT LIFT AXLE, ABS ELECTRICAL & AIR SYSTEM

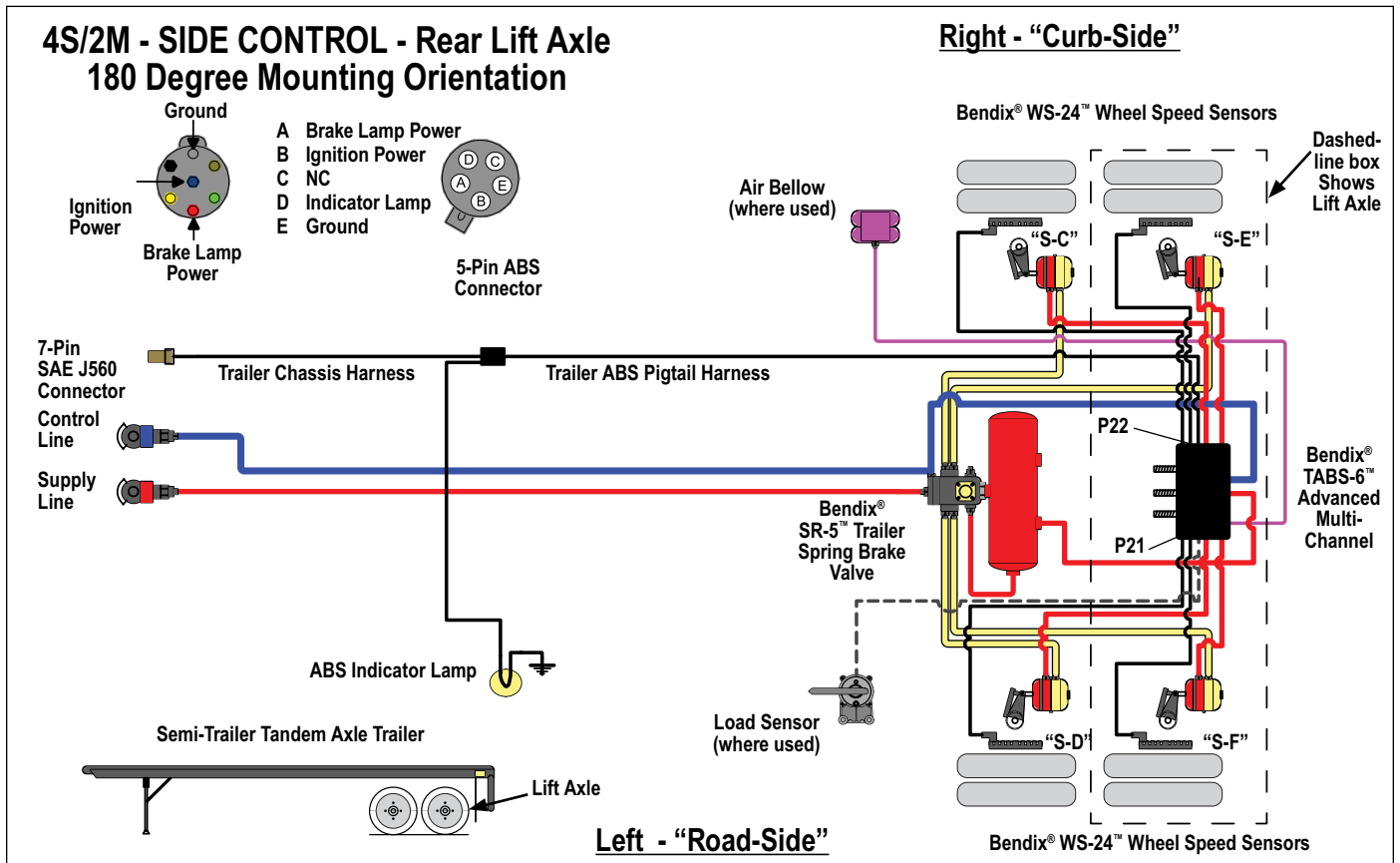

FIGURE 31 - 4S/2M SIDE CONTROL (180 DEGREE) WITH REAR LIFT AXLE, ABS ELECTRICAL & AIR SYSTEM

Troubleshooting: System Schematics

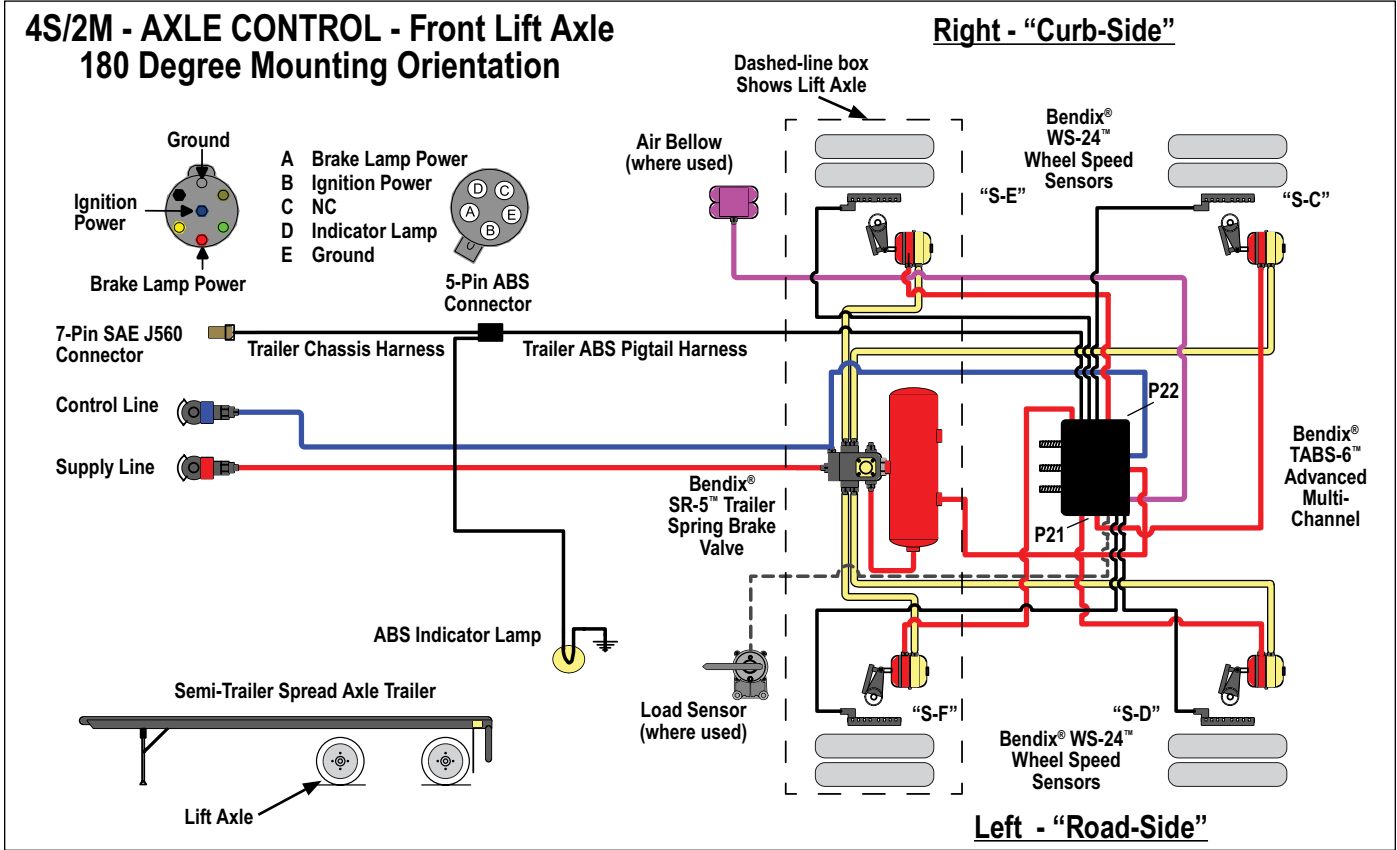

FIGURE 32 - 4S/2M AXLE CONTROL (180 DEGREE) WITH FRONT LIFT AXLE, ABS ELECTRICAL & AIR SYSTEM

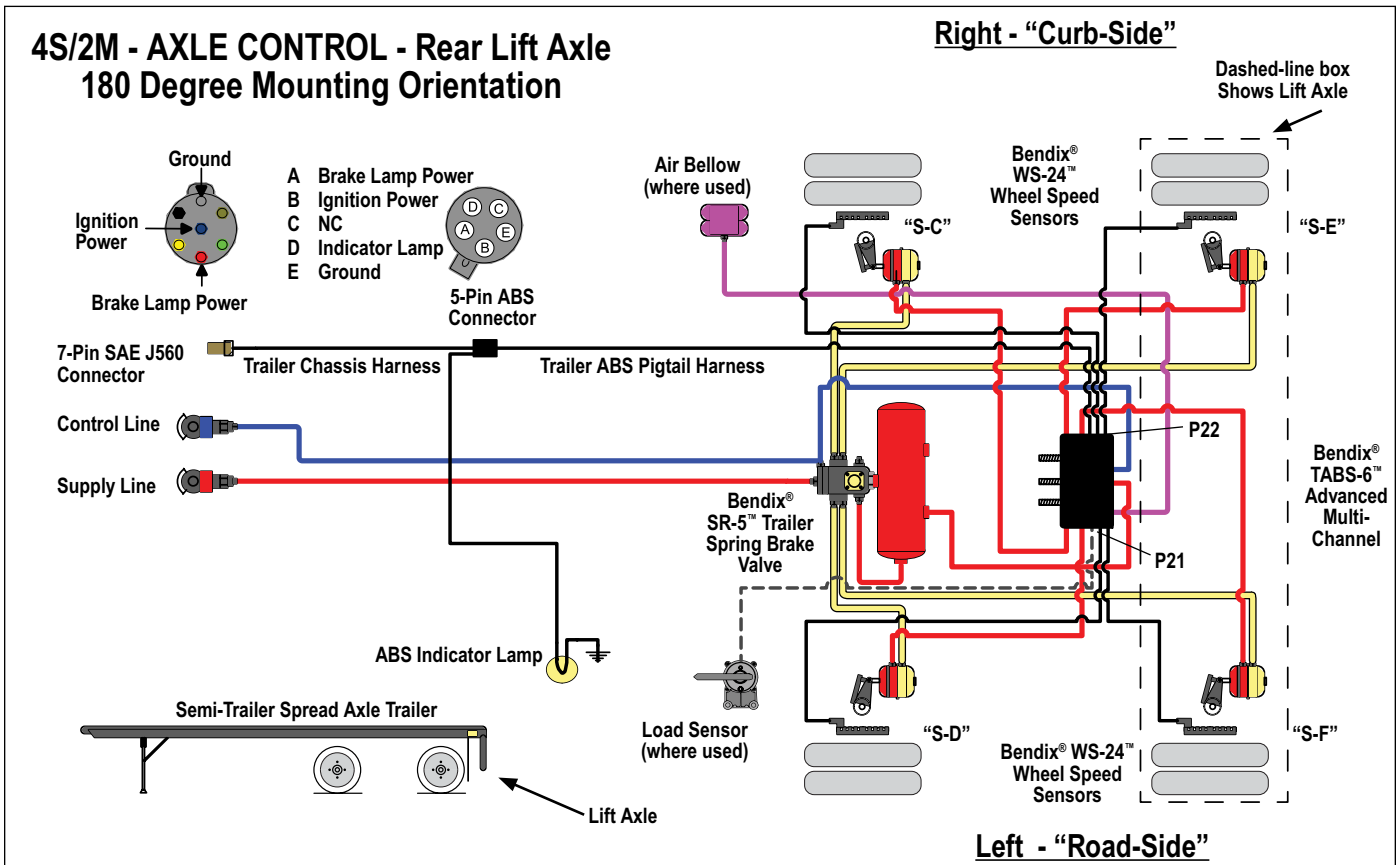

FIGURE 33 - 4S/2M AXLE CONTROL (180 DEGREE) WITH REAR LIFT AXLE, ABS ELECTRICAL & AIR SYSTEM

Troubleshooting: System Schematics

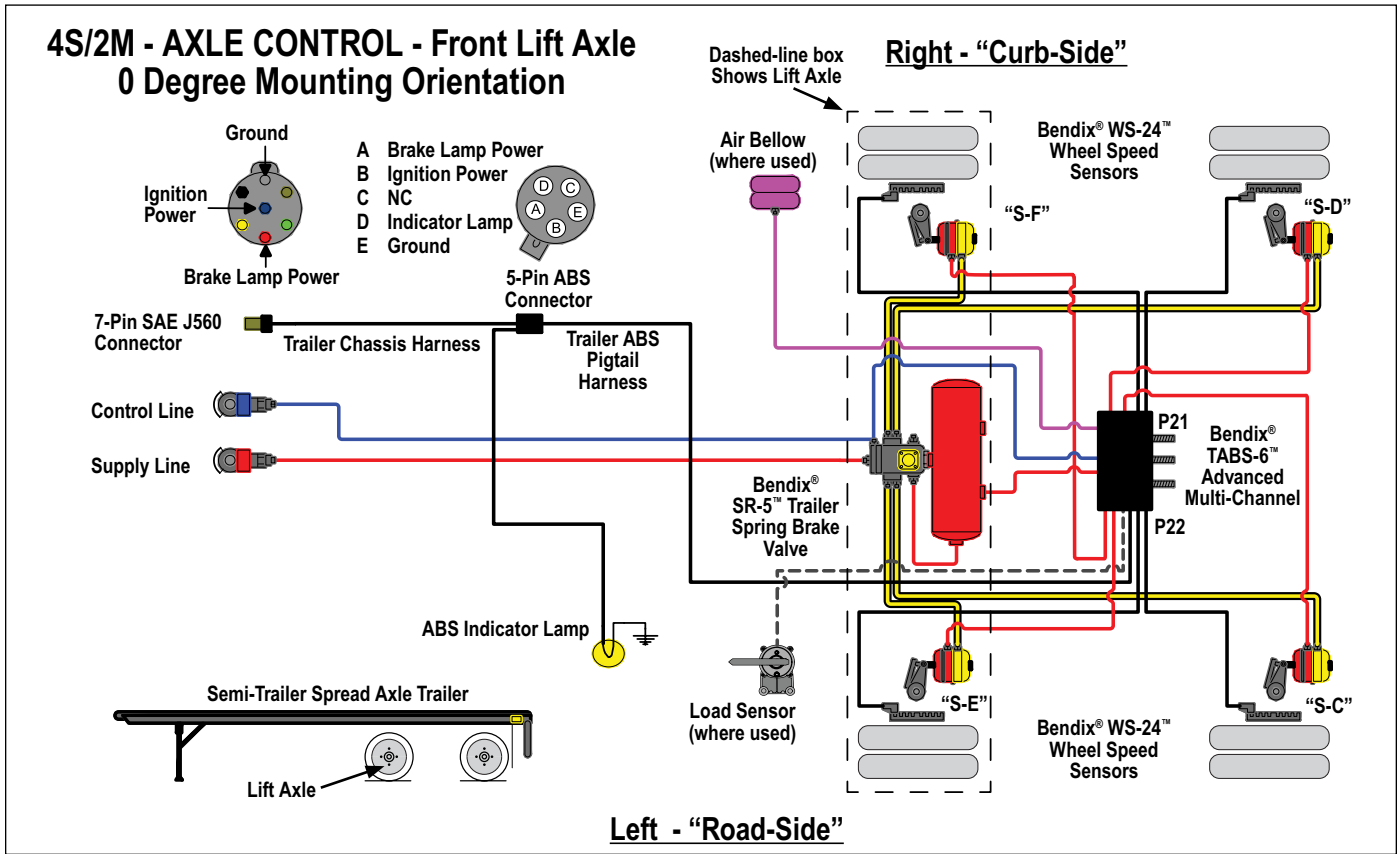

FIGURE 34 - BENDIX® TABS-6™ ADV MC MODULE - TYPICAL 4S/2M SYSTEM WITH FRONT LIFT AXLE

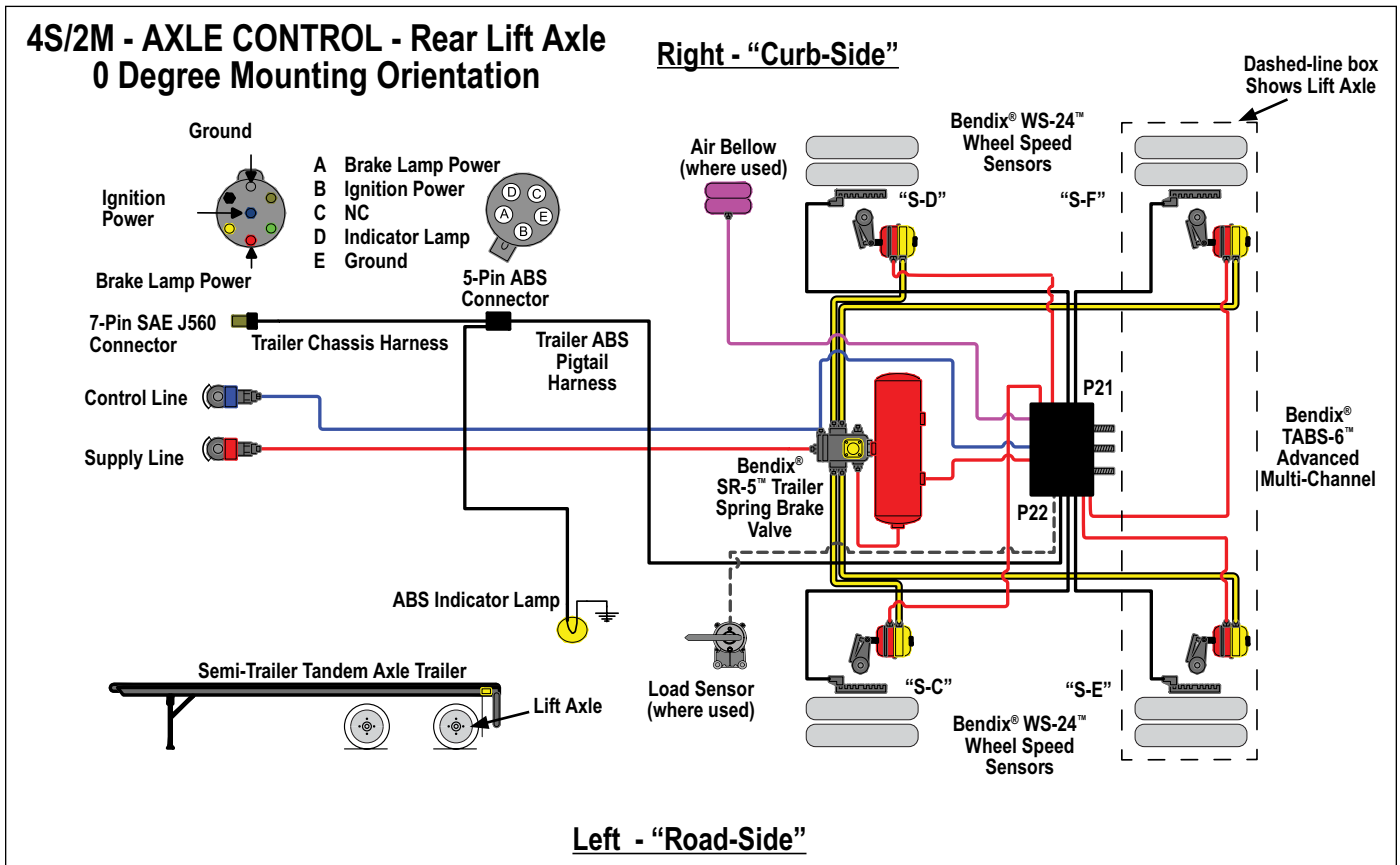

FIGURE 35 - BENDIX TABS-6 ADV MC MODULE - 4S/2M AXLE CONTROL SYSTEM WITH REAR LIFT AXLE

Troubleshooting: Flowcharts

Diagnostic trouble code information can be retrieved from the Bendix® TABS-6™ Adv MC module by using blink code diagnostics, or a diagnostic tool. The following troubleshooting flowcharts will help the technician isolate the cause and confirm whether the problem resides in the component, wiring or connectors.

Troubleshooting should always begin by observing the dash or trailer-mounted ABS indicator lamp during the TABS-6 Adv MC module's power-up sequence. If it is

necessary to take electrical measurements, always begin by taking voltage and resistance measurements at the 7-pin ECU pigtail harness connector.

Once the source of the problem is found, isolate the area needing repair by repeating the measurements at all connections in the affected circuit towards the modulator, wheel speed sensor, etc.

No voltage or resistance measurements are to be made on the bulkhead connector pins of the module.

Section A: (Power-Up Sequence) **Trailer-Mounted ABS Indicator Lamp** **Page 34**
 Section B: (Power-Up Sequence) **Dash-Mounted ABS Indicator Lamp** **Page 35**
 Section C: **Troubleshooting the Trailer-Mounted ABS Indicator Lamp Circuitry** **Page 36**
 Section D: **Troubleshooting the Power Supply** **Page 37**
 Section E: **Troubleshooting the WS-24™ Wheel Speed Sensors** **Page 38**
 Section F: **Troubleshooting the Load Sensor (Out-of-Range Condition)** **Page 39**

SECTION A: POWER-UP SEQUENCE - TRAILER-MOUNTED ABS INDICATOR LAMP

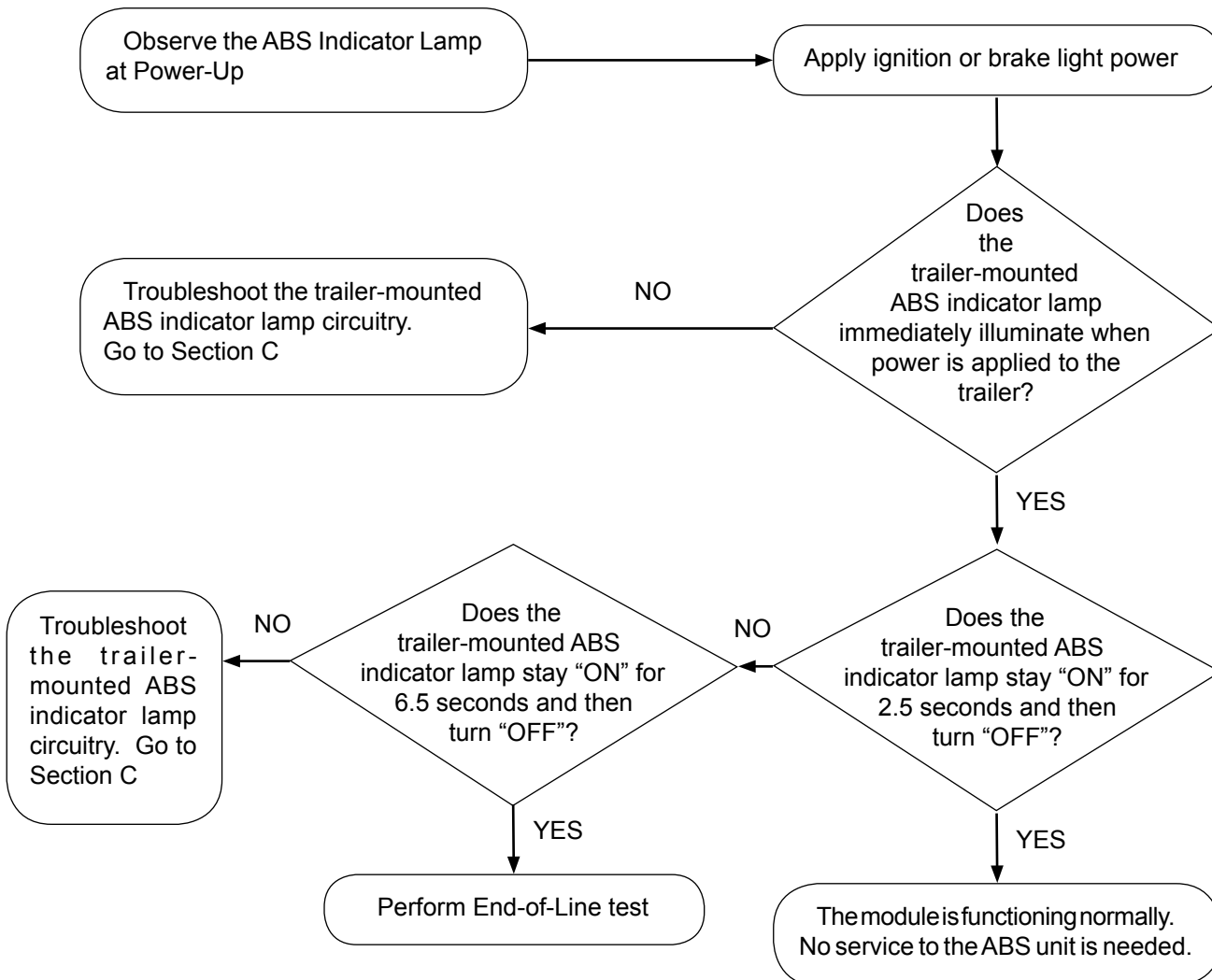

SECTION B: (POWER-UP SEQUENCE) DASH-MOUNTED ABS INDICATOR LAMP

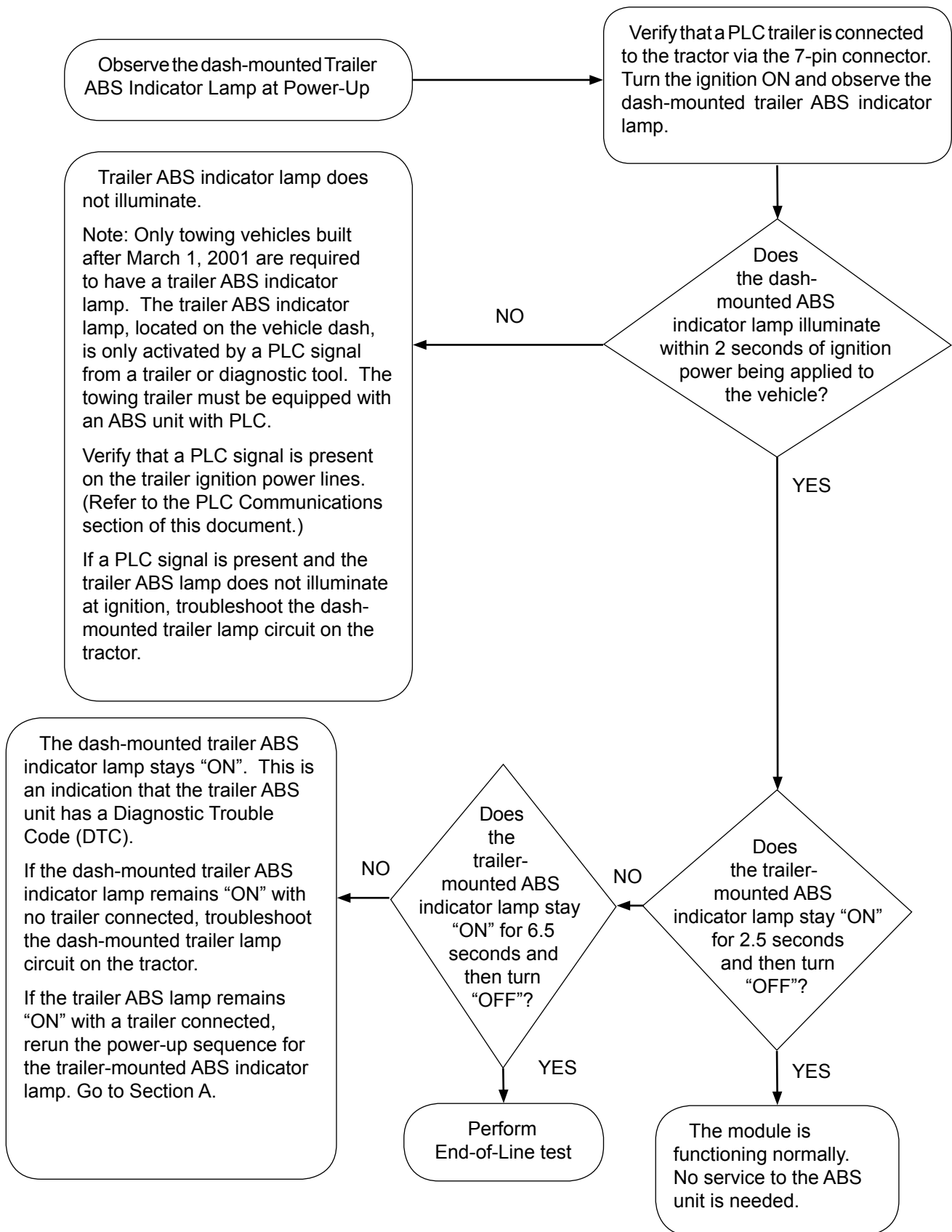

SECTION C: TROUBLESHOOTING THE TRAILER-MOUNTED ABS INDICATOR LAMP CIRCUITRY

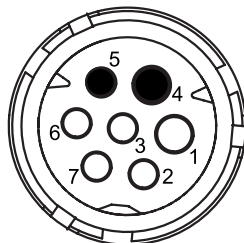
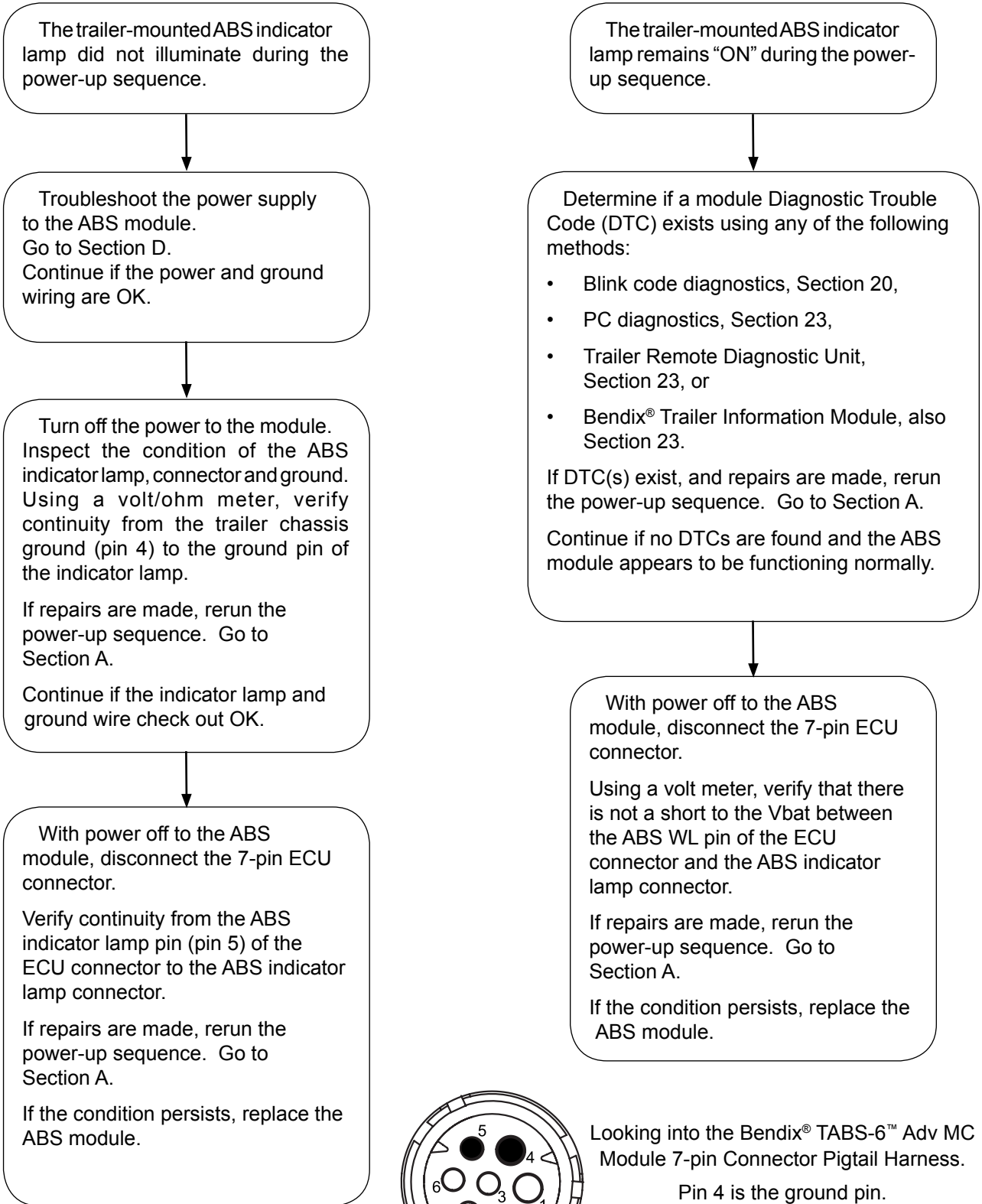

Looking into the Bendix® TABS-6™ Adv MC Module 7-pin Connector Pigtail Harness.

Pin 4 is the ground pin.

Pin 5 is the ABS indicator lamp pin.

SECTION D: TROUBLESHOOTING THE POWER SUPPLY

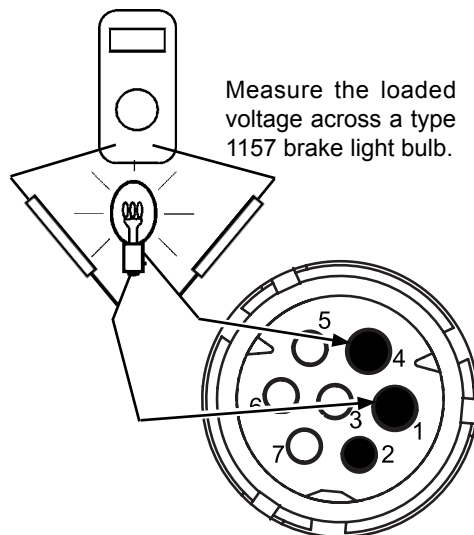
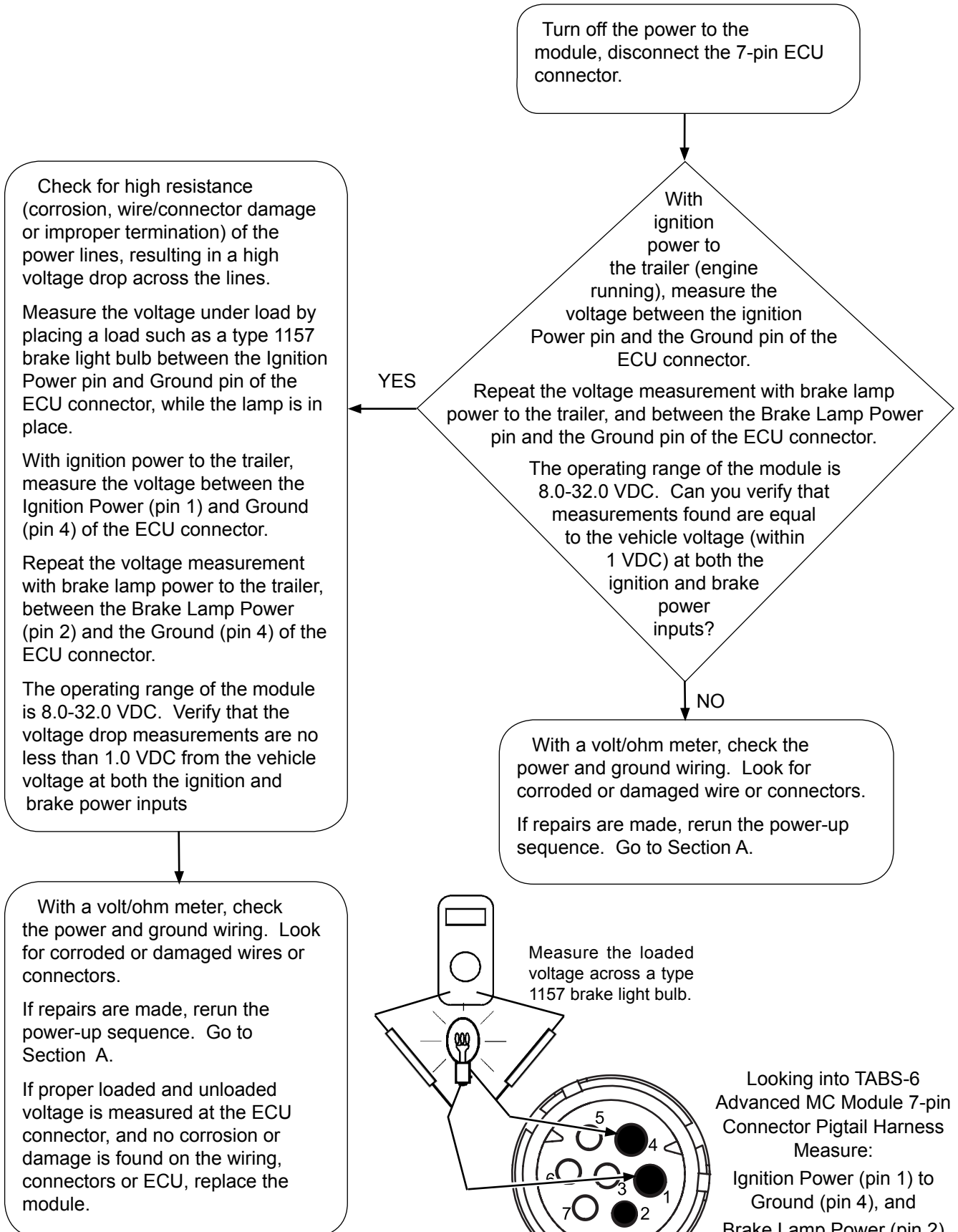

Looking into TABS-6 Advanced MC Module 7-pin Connector Pigtail Harness Measure:
Ignition Power (pin 1) to Ground (pin 4), and Brake Lamp Power (pin 2) to Ground (pin 4).

SECTION E: TROUBLESHOOTING THE BENDIX® WS-24™ WHEEL SPEED SENSORS (WSS)

Turn off the power to the module, disconnect the wheel speed sensor connector.

If Dynamic WSS DTCs are present:

Rotate the affected wheel and verify a minimum of 0.25 VAC sensor output @ 0.5 RPS across the wheel speed sensor pins. A properly positioned sensor can output more than 2.0 VAC @ 1 RPS

Verify/inspect the following:

- Speed sensors properly contact the tone ring.
- The condition and retention force of the sensor sleeve.
- Proper sensor lead condition, routing and clamping sleeve.
- Condition of tone ring mounting and teeth.
- Proper number of tone ring teeth per sensed wheel.
- Proper adjustment of wheel bearings.
- Condition of foundation brakes.
- Check for corroded/damaged wiring or connectors between the ECU and the WSS.

Make repairs as needed (replace wiring and/or ABS components).

Reset active DTC's by using any of the following methods:

- Blink Code Diagnostics, Section 20,
- PC diagnostics, Section 23.
- Bendix Remote Trailer Diagnostic Unit (TRDU) and magnet, Section 23.
- Bendix® Trailer Information Module, Section 23.

(If you do not reset manually, typically these will reset automatically when the vehicle has been driven for a period of time.)

Then rerun the power up sequence. Go to Section A.

If Static WSS DTCs are present:

Using a volt/ohm meter to measure the connector pins of the sensor with a DTC, verify 950-1950 OHMS across the sensor connector pins.

Verify/inspect the following:

- No continuity from sensor connector pins to ground.
- Vbat not measured at either sensor connector pins.
- Verify there is no continuity between the sensor leads and other sensors.
- Sensor/ECU wiring and connectors are not damaged or corroded.
- Proper sensor wire routing and clamping.

Make repairs as needed (replace wiring and/or ABS components).

Reset active DTC's by using any of the following methods:

- Blink Code Diagnostics, Section 20,
- PC diagnostics, Section 23.
- Bendix Remote Trailer Diagnostic Unit (TRDU) and magnet, Section 23.
- Bendix® Trailer Information Module, Section 23.

Then check for Dynamic WSS DTCs, see left column.

Then rerun the power up sequence. Go to Section A.

Note: Both Static and Dynamic WSS DTCs may be present:

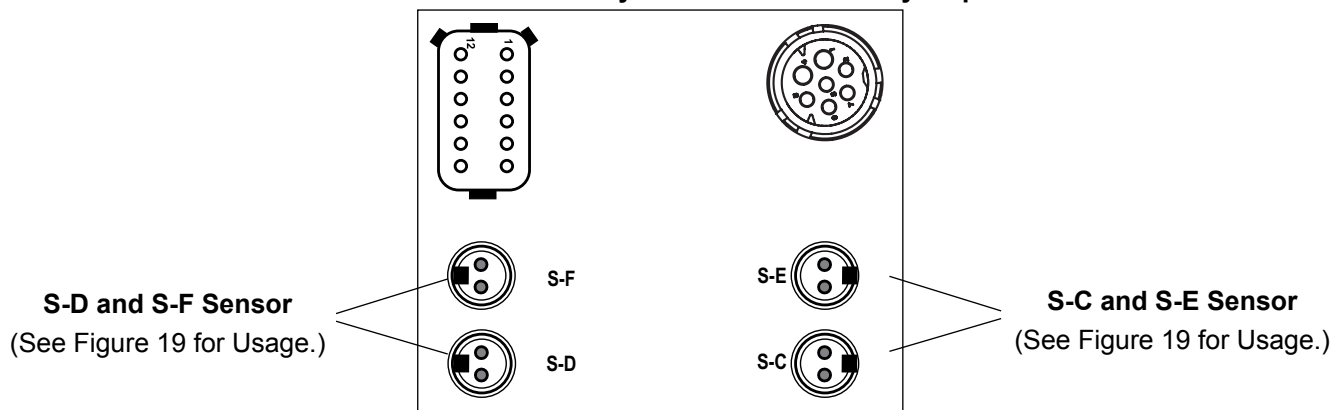

SECTION F: TROUBLESHOOTING THE LOAD SENSOR (OUT-OF-RANGE CONDITION)

(Note: The indicator lamp for this condition is illuminated only after the vehicle moves.)

Turn off the power to the module.

For spring suspension system trailers:

Verify/inspect the following:

1. Inspect the load sensor linkage:
 - Check that the linkage is attached to the axle clamp.
 - Inspect for damage to the linkage components, loose connectors and mis-installation.
 - Check that the load sensor lever rod is in a horizontal position with the trailer empty.
 - Verify that the sensor linkage has not flipped over so that it faces the opposite direction.
2. Switch on power to the module. Using Bendix® ACom® Diagnostics, open the TRSP Sensors screen and press “Start.” Find the load (in lbs.) that the sensor is registering, and verify that the actual trailer load is consistent with the value found. Where the value does not appear to be correct, perform the load sensor resistance check:
 - Unplug the 12-pin connector from the module.
 - With the load sensor lever in the horizontal position, verify that approximately 2.5K Ohms is measured between pins four (4) and five (5) and between pins five (5) and six (6). Using Bendix ACom Diagnostics open the configuration screen, then the Load and Sensor Configuration tab, and select the “Load Sensing” panel. Verify that the current “Sensing Type” is shown as “External.” If not, change the selection to “External.”

Where the value does not appear to be correct, enter the correct value(s) on the configuration screen. If your version of Bendix ACom Diagnostics does not permit you to make these changes, update your copy of the program (available as a free download from the support pages at www.bendix.com.)

Note: Use a scale to obtain the actual empty trailer weight and use a pressure gauge to obtain actual empty trailer suspension air bag pressure. Where possible, obtain the load\pressure curve from the suspension manufacturer for the specific suspension\air bag combination to find the expected values for this vehicle.

Then rerun the power up sequence. Go to Section A.

For air suspension system trailers:

Verify/inspect the following:

1. Check that port P42 is connected by an unknicked air hose to the primary suspension air bags.
2. Check that the suspension height control valve is functioning correctly.
3. Check for air leakage in the suspension system.
4. Switch on power to the module. Using Bendix® ACom® Diagnostics, open the TRSP Sensors screen and select “Start.” Find the load (in lbs.) that the sensor is registering, and verify that the actual trailer load is consistent with the value found.
5. Where the value does not appear to be correct, using Bendix ACom Diagnostics, open the “Pressures” screen and select “Start.” Read the pressure shown for the airbag port (P42). If the load value, or pressure value are not as expected, open the “Configuration” screen; then the Load and Sensor Configuration tab, and select the “Load Sensing” panel. Verify that the current “Sensing Type” is shown as “Internal.” If not, change the selection to “Internal.”

Note the values shown on the screen for the current load and pressure. Verify that the values shown on the screen for the empty and laden weight and voltage are correct.

Where the value does not appear to be correct, enter the correct value(s) on the configuration screen. If your version of Bendix ACom Diagnostics does not permit you to make these changes, update your copy of the program (available as a free download from the support pages at www.bendix.com.)

Note: Use a scale to obtain the actual empty trailer weight and use a pressure gauge to obtain actual empty trailer suspension air bag pressure. Where possible, obtain the load\pressure curve from the suspension manufacturer for the specific suspension\air bag combination to find the expected values for this vehicle.

Then rerun the power up sequence. Go to Section A.

ECU Part Number Label

The external part number label is located above the control port of the module. If this label is not readable for any reason, the Bendix part number is etched into the module casting above the control port (See Figure 1). A Bendix manufacturing date code is to the right of the part number inscription.

There is an additional label under one of the covers that shows a pin-out diagram for the 12-pin auxiliary connector.

Software Revision Level

The number of the initial software loaded on the ECU is also indicated. The current software revision number can be read using a diagnostic tool.

Document Revision Level

Please visit Bendix.com to ensure you have the latest version of this document.

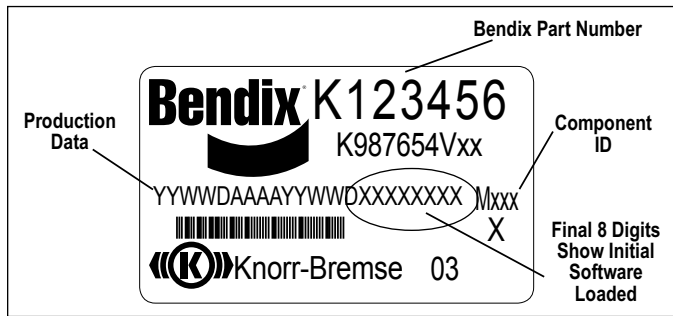

FIGURE 36 - LABEL INFORMATION

Log-on and Learn from the Best
On-line training that's available when you are — 24/7/365.
Visit www.brake-school.com.

