

Bendix® E-6® & E-10™ Dual Brake Valves

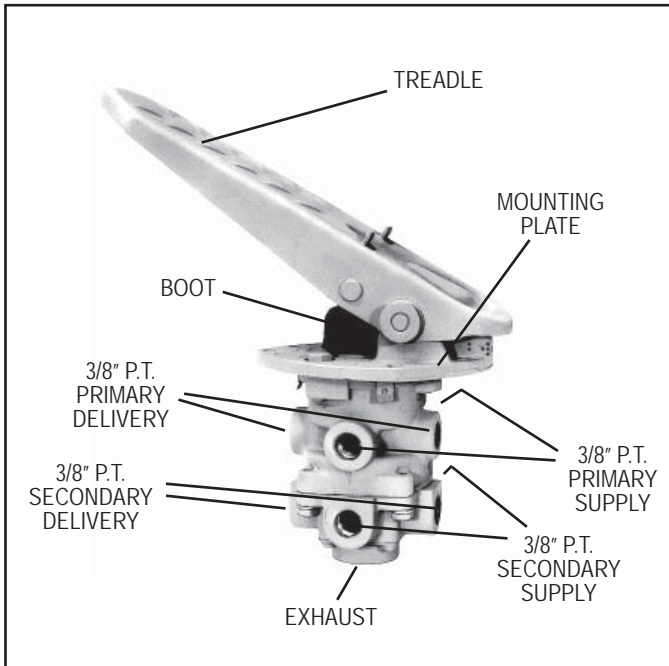

FIGURE 1 - BENDIX® E-6® DUAL BRAKE VALVE

DESCRIPTION

The Bendix® E-6® (Figure 1) and E-10™ (Figure 2) dual brake valves are floor-mounted, treadle-operated type brake valves with two separate supply and delivery circuits for service (primary) and secondary braking. Each provides the driver with a graduated control for applying and releasing the vehicle brakes.

The E-10™ dual brake valve (Figure 2) is similar to the E-6® dual brake valve except that a metal coil spring housed in an upper body assembly replaces the rubber spring used in the E-6® valve. The use of a metal coil spring (and the upper body assembly) provides greater treadle travel and, therefore, provides the driver with a less sensitive “feel” when making a brake application. The E-10™ dual brake valve is generally used on buses, where smooth brake applications contribute to passenger comfort.

The circuits in the Bendix® E-6/E-10 dual brake valves are identified as follows: The primary circuit is that portion of the valve between the spring seat which contacts the plunger and the relay piston; the secondary circuit is that portion between the relay piston and the exhaust cavity.

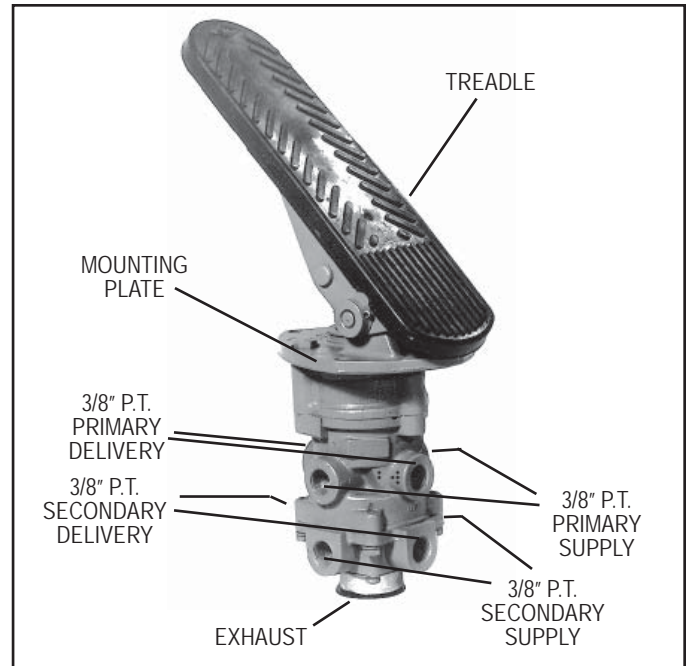

FIGURE 2 - BENDIX® E-10™ DUAL BRAKE VALVE

The primary circuit of the valve is similar in operation to a standard single circuit air brake valve, and – under normal operating conditions – the secondary circuit is similar in operation to a relay valve.

Both primary and secondary circuits of the brake valve use a common exhaust protected by an exhaust diaphragm.

OPERATION

APPLYING: NORMAL OPERATION - PRIMARY CIRCUIT PORTION

When the brake treadle is depressed, the plunger exerts force on the spring seat, graduating spring, and primary piston. The primary piston, which contains the exhaust valve seat, closes the primary exhaust valve. As the exhaust valve closes, the primary inlet valve is moved off its seat, allowing primary air to flow out the primary delivery port.

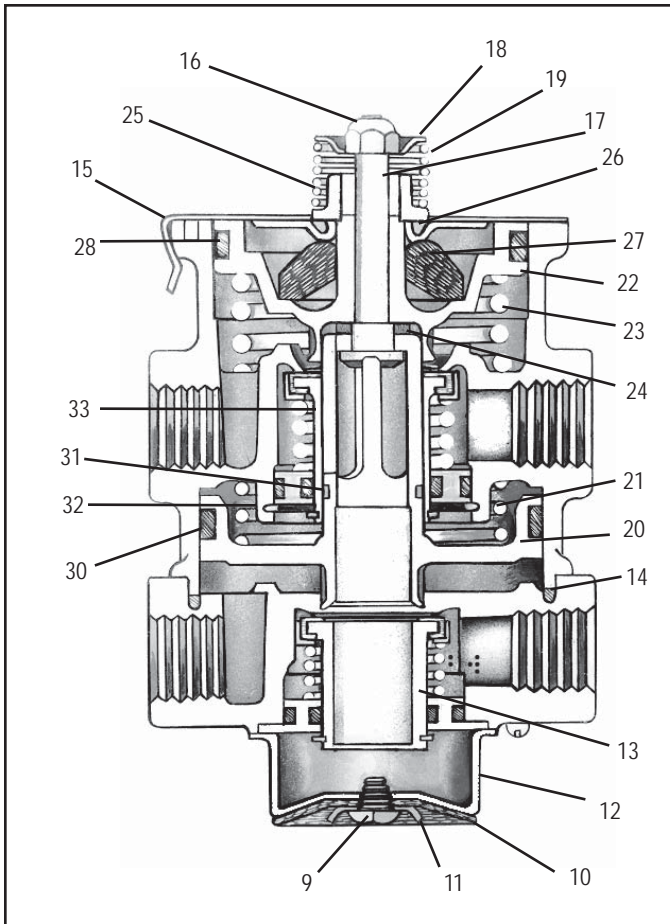

FIGURE 3 - BENDIX® E-6® DUAL BRAKE VALVE SECTIONAL DIAGRAM

APPLYING: NORMAL OPERATION - SECONDARY CIRCUIT

When the primary inlet valve is moved off its seat, air is permitted to pass through the bleed passage and enters the relay piston cavity. The air pressure moves the relay piston, which contains the exhaust seat, and closes the secondary exhaust valve. As the secondary exhaust valve closes, the secondary inlet valve is moved off its seat allowing the secondary air to flow out the secondary delivery port. Because of the small volume of air required to move the relay piston, action of the secondary circuit of the valve is almost simultaneous with the primary circuit portion.

APPLYING: LOSS OF AIR IN THE SECONDARY CIRCUIT

Should air be lost in the secondary circuit, the primary circuit will continue to function as described above under *Normal Operation: Primary Circuit Portion*.

APPLYING: LOSS OF AIR IN THE PRIMARY CIRCUIT

Should air be lost in the primary circuit, the function will be as follows: as the brake treadle is depressed – and no air pressure is present in the primary circuit supply and

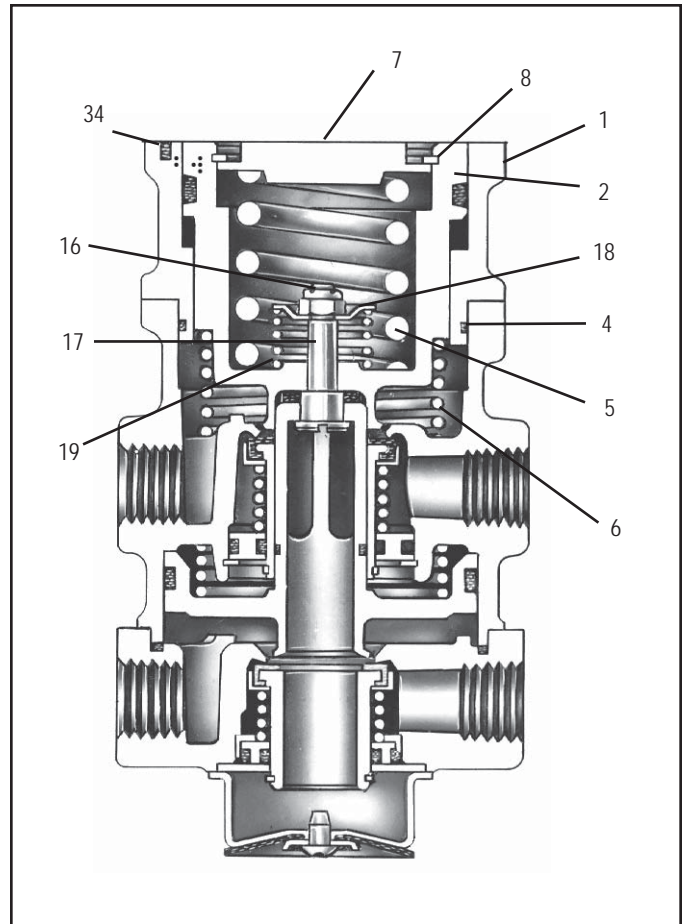

FIGURE 4 - BENDIX® E-10™ DUAL BRAKE VALVE SECTIONAL DIAGRAM

delivery ports – the primary piston will mechanically move the relay piston, allowing the piston to close the secondary exhaust valve and open the secondary inlet valve, allowing air to flow out the secondary delivery port.

BALANCED: PRIMARY CIRCUIT

When the primary delivery pressure acting on the piston equals the mechanical force of the brake pedal application, the primary piston will move and the primary inlet valve will close, stopping further flow of air from the primary supply line through the valve. The exhaust valve remains closed, preventing any escape of air through the exhaust port.

BALANCED: SECONDARY CIRCUIT

When the air pressure on the secondary side of the relay piston approaches that being delivered on the primary side of the relay piston, the relay piston moves, closing the secondary inlet valve and stopping further flow of air from the supply line through the valve. The exhaust remains closed as the secondary delivery pressure balances the primary delivery pressure.

When applications in the graduating range are made, a balanced position in the primary circuit is reached as the air pressure on the delivery side of the primary piston equals

the effort exerted by the driver's foot on the treadle. A balanced position in the secondary portion is reached when air pressure on the secondary side of the relay piston closely approaches the air pressure on the primary side of the relay piston.

When the brake treadle is fully depressed, both the primary and secondary inlet valves remain open and full reservoir pressure is delivered to the actuators.

RELEASING: PRIMARY CIRCUIT

With the brake treadle released, mechanical force is removed from the spring seat, graduating spring, and primary piston. Air pressure and spring load moves the primary piston, opening the primary exhaust valve, allowing air pressure in the primary delivery line to exhaust out the exhaust port.

RELEASING: SECONDARY CIRCUIT

With the brake treadle released, air is exhausted from the primary circuit side of the relay piston. Air pressure and spring load move the relay piston, opening the secondary exhaust valve allowing air pressure in the secondary delivery line to exhaust out the exhaust port.

PREVENTIVE MAINTENANCE

Important: Review the Bendix® Warranty Policy before performing any intrusive maintenance procedures. A warranty may be voided if intrusive maintenance is performed during the warranty period.

No two vehicles operate under identical conditions, as a result, maintenance intervals may vary. Experience is a valuable guide in determining the best maintenance interval for air brake system components. At a minimum, the Bendix® E-6®/E-10™ valves should be inspected every 6 months or 1500 operating hours, whichever comes first, for proper operation. Should the E-6®/E-10™ valves not meet the elements of the operational tests noted in this document, further investigation and service of the valve may be required.

Visually check for physical damage to the brake valve such as broken air lines and broken or missing parts.

Every three (3) months, 25,000 miles, or 900 operating hours:

Clean any accumulated dirt, gravel, or foreign material away from the heel of the treadle, plunger boot, and mounting plate.

Lubricate the treadle roller, roller pin, and hinge pin, with Barium grease per BW-204-M (Bendix part 246671).

Check the rubber plunger boot for cracks, holes or deterioration and replace if necessary. Also, check mounting plate and treadle for integrity.

Apply a thin layer of Barium grease, per BW-204-M (Bendix part 246671), between plunger and mounting plate – **do not over oil!**

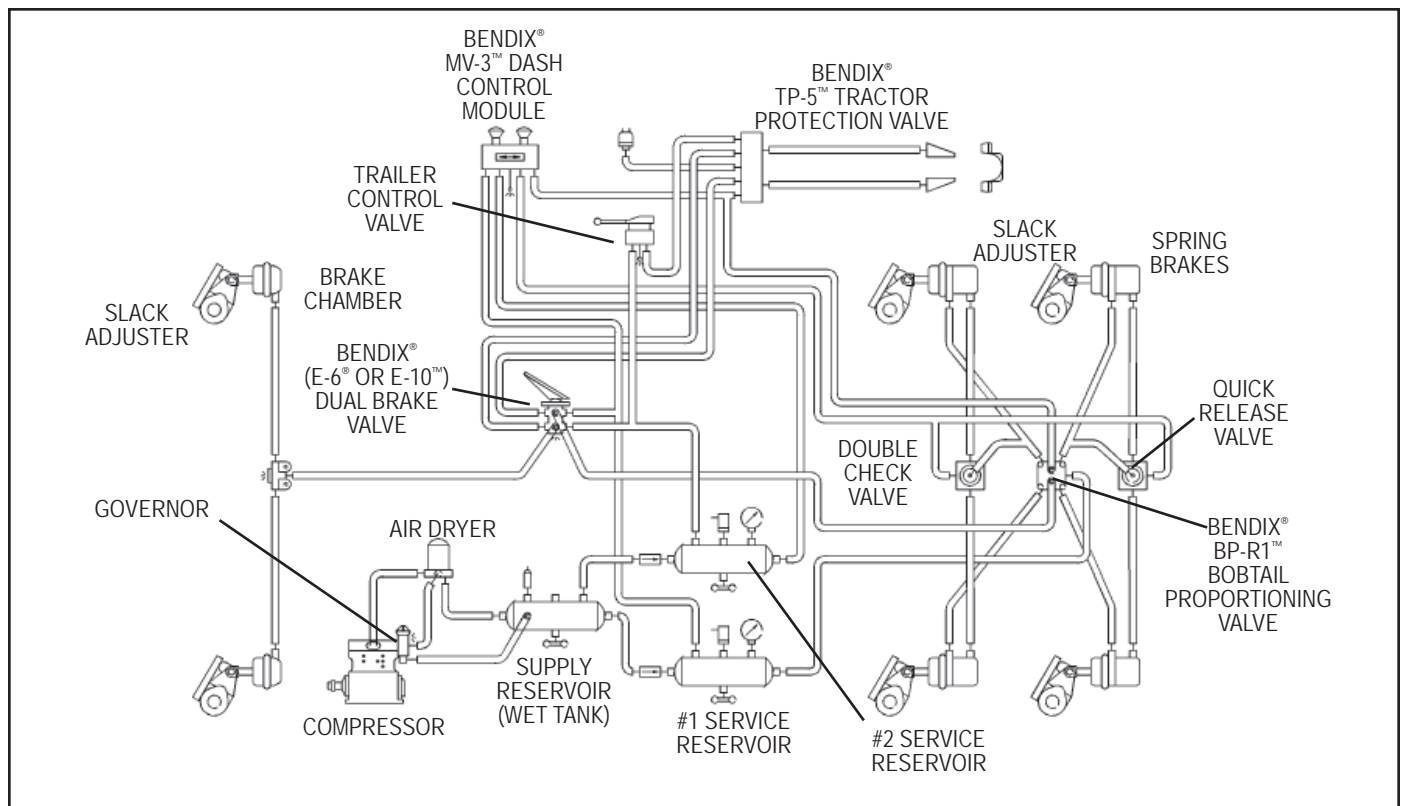

FIGURE 5 - TYPICAL PIPING SCHEMATIC

SERVICE CHECKS

OPERATING CHECK

Check the delivery pressure of both primary and secondary circuits using accurate test gauges. Depress the treadle to several positions between the fully released and fully applied positions, and check the delivered pressure on the test gauges to see that it varies equally and proportionately with the movement of the brake pedal.

After a full application is released, the reading on the test gauges should fall off to zero promptly. It should be noted that the primary and secondary delivery pressures may vary by up to 5 psi for standard valves or up to 7.5 psi for high differential valves with both supply reservoirs at the same pressure. This is normal for this valve.

Important: A change in vehicle braking characteristics or a low pressure warning may indicate a malfunction in one or the other brake circuit, and although the vehicle air brake system may continue to function, the vehicle should not be operated until the necessary repairs have been made and both braking circuits, including the pneumatic and mechanical devices, are operating normally. Always check the vehicle brake system for proper operation after performing brake work and before returning the vehicle to service.

LEAKAGE CHECK

1. Make and hold a high pressure (80 psi) application.
2. Coat the exhaust port and body of the brake valve with a soap solution.
3. Leakage permitted is a 1" bubble in 3 seconds. If the brake valve does not function as described above or leakage is excessive, it is recommended that it be replaced with a new or remanufactured unit, or repaired with genuine Bendix® parts available at authorized Bendix® parts outlets.

REMOVAL

1. Check the vehicle wheels or park the vehicle by mechanical means. Drain all air system reservoirs.
2. Identify and disconnect all supply and delivery lines at the brake valve.
3. Remove the brake valve and treadle assembly from the vehicle by removing the three cap screws on the outer bolt circle of the mounting plate. The basic brake valve alone can be removed by removing the three cap screws on the inner bolt circle.

DISASSEMBLY (Figures 3 and 4)

1. If the entire brake valve and treadle assembly was removed from the vehicle, remove the three cap screws securing the treadle assembly to the basic brake valve.

2. Remove the screw (9) securing the exhaust diaphragm (10) and washer (11) to the exhaust cover (12).
3. Remove the four screws that secure the exhaust cover (12) to the lower body.
4. Remove the Secondary inlet and exhaust valve assembly (13) from the lower body.
5. Remove the four hex head cap screws securing the lower body to the upper body and separate the body halves.
6. Remove the rubber seal ring (14) from the lower body.

BENDIX® E-6® BRAKE VALVE ONLY (Figure 3):

7. While applying thumb pressure to the primary piston, lift out and up on the three lock tabs of the primary piston retainer (15).

BENDIX® E-10™ BRAKE VALVE ONLY (Figure 4):

8. A. While depressing the spring seat (7), remove retaining ring (8).
B. Remove the spring seat and coil spring (5).
9. Using a 3/8" wrench, hold the lock nut (16) on the threaded end of the stem (17) in the primary piston (2). Insert a screwdriver in the exhaust passage through the center of the valve and engage the slotted head of the stem.
10. Remove lock nut (16), spring seat (18), stem spring (19), primary piston (2), and primary piston return spring (6). Remove o-ring (34).
11. Remove adapter (1). Remove o-ring (4) from adapter. Caution: Before proceeding with the disassembly, refer to Figure 4 and note that the lock nut and stem are used to contain the primary piston return spring, stem spring and the relay piston spring. The combined force of these springs is approximately 50 pounds and care must be taken when removing the lock nut as the spring forces will be released. It is recommended that the primary piston and relay piston be manually or mechanically contained while the nut and stem are being removed.

BENDIX® E-6® BRAKE VALVE ONLY:

12. Using a screwdriver to restrain the stem, as in step nine, remove the lock nut (16), spring seat (18) and stem spring (19).
13. Remove the relay piston (20), relay piston spring (21), primary piston and primary piston return spring (23) from the upper body. Use care so as not to nick seats.

Note: Certain E-6® brake valves do not have a relay piston spring (21). If this spring is not found, do not install a replacement.

14. On valves manufactured after October 7, 1976, a small washer (24) will be found in the cavity in the lower side of the primary piston (22).

15. Disassemble the primary piston by rotating the spring seat nut (25) counterclockwise. Separate the spring seat nut, spring seat (26), rubber spring (27) and remove the piston o-ring (28).
16. Remove the large (30) and small (31) o-rings from the relay piston (20).
17. Remove the retaining ring (32) securing the primary inlet and exhaust valve assembly (33) in the upper body and remove the valve assembly.

CLEANING AND INSPECTION

1. Wash all metal parts in mineral spirits and dry.
2. Inspect all parts for excessive wear or deterioration.
3. Inspect the valve seats for nicks or burrs.
4. Check the springs for cracks or corrosion.
5. Replace all rubber parts and any part not found to be serviceable during inspection, using only genuine Bendix® brand replacement parts.

ASSEMBLY

Prior to reassembling, lubricate all o-rings, o-ring grooves, piston bores and metal to metal moving surfaces with Dow Corning 55 M pneumatic grease (Bendix piece number 291126).

Note: All torques specified in this manual are assembly torques and can be expected to fall off, after assembly is accomplished. Do not retorque after initial assembly torques fall.

1. Install the primary inlet and exhaust assembly (33) in the upper body and replace the retaining ring (32) to secure it. Be sure the retaining ring is seated completely in its groove.
2. Install the large (30) and small (31) o-rings on the relay piston.
3. Install the primary piston o-ring (28) in the piston o-ring groove.

BENDIX® E-6® BRAKE VALVE ONLY:

4. Install the rubber spring (do not lubricate) (27), concave side down in the primary piston (22) and place the spring seat (26), flat side up, over the rubber spring.
5. Install the primary piston spring seat nut (25), with its hex closest to the spring seat, and rotate clockwise until the top surface of the spring seat is even with the top surface of the piston. Set aside.
6. Install large (30) and small (31) o-rings on relay piston (20).
7. Place relay piston, spring (21) (if used) in concave portion of relay piston and install relay piston through No. 1 inlet/exhaust assembly (33) and into under side of upper body.

8. Place screwdriver, blade up, in vise. Place stem (17) in relay piston upper body sub assembly over the blade of the screwdriver with blade engaged in the slot in the head of the stem.
9. Place the washer (24) over the stem. This washer should be installed in all valves.
10. Install primary return spring (23) in upper body piston bore.
11. Install the primary piston rubber spring sub assembly (steps 4 & 5) over the stem, into the upper body piston bore.
12. Compress the primary and relay pistons into the upper body from either side and hold them compressed, either manually or mechanically. See the cautionary note under step 11 in the Disassembly section of this manual.
13. Place the stem spring (19) over the spring seat nut (25) and the spring seat (18) over the stem.
14. Install the lock nut (16) on the stem and torque to 20 - 30 inch pounds.
15. Install the primary piston retainer (15) over the piston, making certain all three lock tabs have engaged the outer lip of the body.

GENERAL SAFETY GUIDELINES

WARNING! PLEASE READ AND FOLLOW THESE INSTRUCTIONS TO AVOID PERSONAL INJURY OR DEATH:

When working on or around a vehicle, the following general precautions should be observed at all times.

1. **Park the vehicle on a level surface, apply the parking brakes, and always block the wheels. Always wear safety glasses.**
2. **Stop the engine and remove ignition key when working under or around the vehicle. When working in the engine compartment, the engine should be shut off and the ignition key should be removed. Where circumstances require that the engine be in operation, EXTREME CAUTION should be used to prevent personal injury resulting from contact with moving, rotating, leaking, heated or electrically charged components.**
3. **Do not attempt to install, remove, disassemble or assemble a component until you have read and thoroughly understand the recommended procedures. Use only the proper tools and observe all precautions pertaining to use of those tools.**

4. If the work is being performed on the vehicle's air brake system, or any auxiliary pressurized air systems, make certain to drain the air pressure from all reservoirs before beginning **ANY** work on the vehicle. If the vehicle is equipped with a Bendix® AD-IS® air dryer system or a dryer reservoir module, be sure to drain the purge reservoir.
5. Following the vehicle manufacturer's recommended procedures, deactivate the electrical system in a manner that safely removes all electrical power from the vehicle.
6. Never exceed manufacturer's recommended pressures.
7. Never connect or disconnect a hose or line containing pressure; it may whip. Never remove a component or plug unless you are certain all system pressure has been depleted.
8. Use only genuine Bendix® brand replacement parts, components and kits. Replacement hardware, tubing, hose, fittings, etc. must be of equivalent size, type and strength as original equipment and be designed specifically for such applications and systems.
9. Components with stripped threads or damaged parts should be replaced rather than repaired. Do not attempt repairs requiring machining or welding unless specifically stated and approved by the vehicle and component manufacturer.
10. Prior to returning the vehicle to service, make certain all components and systems are restored to their proper operating condition.
11. For vehicles with Automatic Traction Control (ATC), the ATC function must be disabled (ATC indicator lamp should be ON) prior to performing any vehicle maintenance where one or more wheels on a drive axle are lifted off the ground and moving.

