

Bendix® SL-3™ & SL-4™ Stop Light Switch

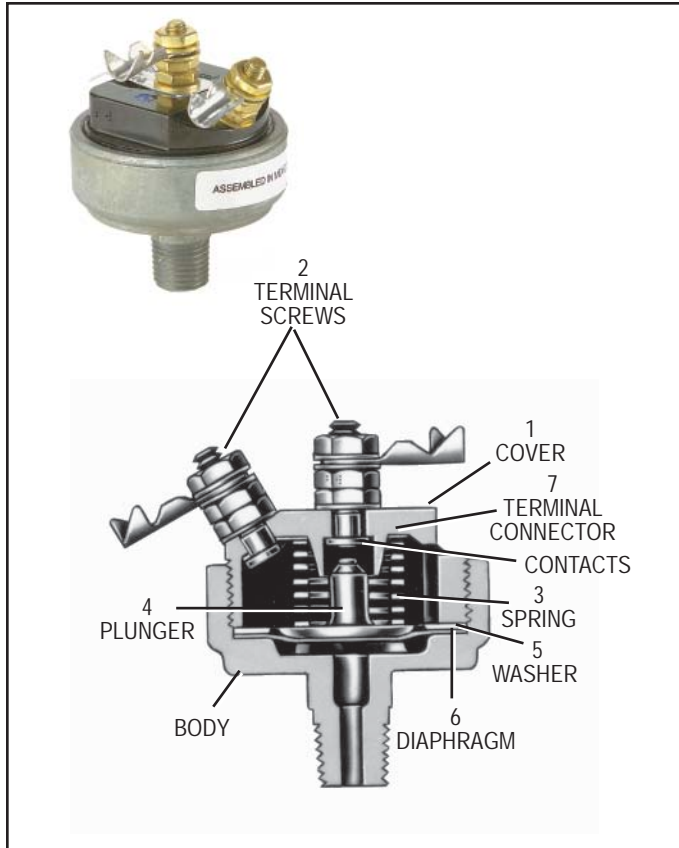

FIGURE 1 - BENDIX® SL-3™ STOP LIGHT SWITCH

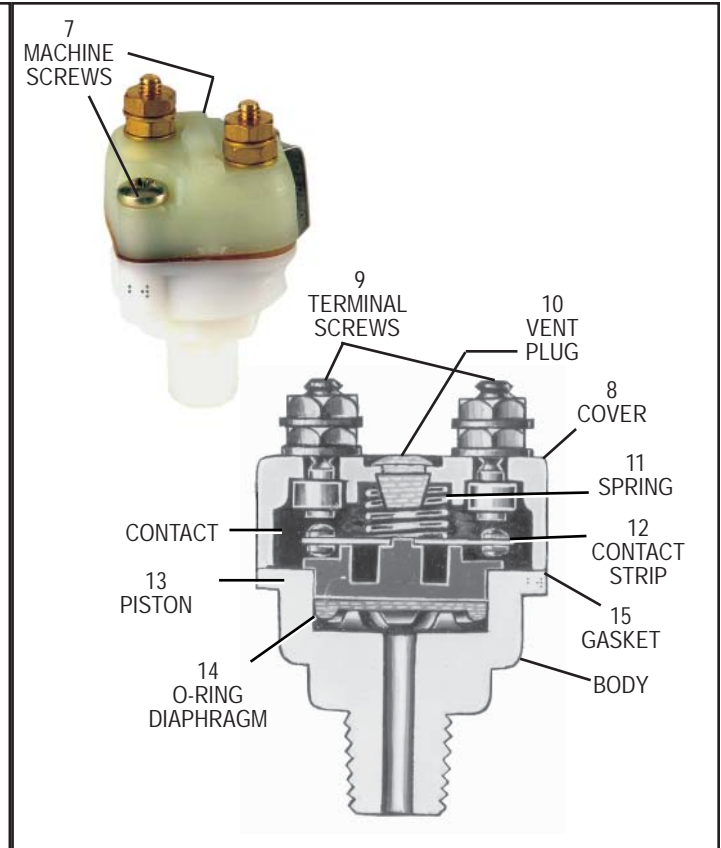

FIGURE 2 - BENDIX® SL-4™ STOP LIGHT SWITCH

DESCRIPTION

The stop light switch is an electro-pneumatic switch and operates in conjunction with the brake valve and stop lights by completing the electrical circuit when a brake application is made.

OPERATION

When a brake application is made, air pressure from the brake valve enters the cavity below the diaphragm. At approximately 5 psi, the air pressure underneath the diaphragm overcomes the force of the spring and moves the piston or plunger until the contact points close, completing the stop light electrical circuit and lighting the stop lights.

PREVENTIVE MAINTENANCE

Important: Review the Bendix Warranty Policy before performing any intrusive maintenance procedures. A warranty may be voided if intrusive maintenance is performed during the warranty period.

No two vehicles operate under identical conditions; as a result, maintenance intervals may vary. Experience is a valuable guide in determining the best maintenance interval for air brake system components. At a minimum, the Bendix® SL-3™ and SL-4™ switches should be inspected every 6 months or 1500 operating hours, whichever comes first, for proper operation and electrical connections. Should the SL-3™ or SL-4™ switch not meet the elements of the operational tests noted in this document, further investigation and service of the valve may be required.

TESTING FOR SERVICEABILITY

OPERATING TEST

1. Apply the brake valve and note that the stop light lights before the delivery pressure reaches 7 psi.
2. Release the brake valve and note that the stop light goes "off".

LEAKAGE TEST

1. With the brakes fully applied, no leakage is permitted at the stop light switch. If the stop light switch does not function as described or if leakage is excessive, it is recommended that it be replaced with a new unit or repaired with genuine Bendix® brand replacement parts available at authorized Bendix parts outlets.

REMOVING

1. Disconnect the electrical connections at the stop light switch.
2. Disconnect the air line to the stop light switch.
3. Remove the stop light switch.

INSTALLING

1. Install in a convenient location for servicing.
2. Install with the pipe tap pointing to the ground and keep it high for adequate drainage.
3. Connect the stop light switch in series in the stop light circuit.
4. Keep the stop light switch terminals away from frame members to avoid grounding.
5. Connect the pipe tap to the brake chamber supply line so that the stop light switch will operate whether the foot or hand valve is applied.

DISASSEMBLY

BENDIX® SL-3™ SWITCH

1. Place hex portion of body in a vise.
2. Using a large end wrench on cover flats, turn cover (1) in a counterclockwise direction and remove from body.
3. Remove terminal nuts, terminal screws (2) and terminal connector (7) from cover.
4. Remove spring (3), plunger (4), washer (5) and diaphragm (6) from body.

BENDIX® SL-4™ SWITCH

1. Remove two machine screws (7) and remove cover (8).
2. Remove the terminal nuts and terminals (9) from cover.
3. Remove the vent plug (10) from cover.
4. Remove spring (11), contact strip (12), piston (13) and o-ring diaphragm (14) from body.

CLEANING AND INSPECTION

Clean all metal parts in cleaning solvent. Wipe rubber parts dry with a cloth.

Inspect contact points for pits or wear. If pitting is not too severe, the points may be reconditioned by filing with a distributor point file. If points cannot be reconditioned, they should be replaced. The contact strip in the SL-4™ switch may be turned over to use the other side of the contacts.

Check the spring for signs of deterioration; Replace if discolored. The spring in the SL-3™ switch carries the current of the electrical circuit involved; consequently, in the case of excessive current, as might be caused by a short, the spring will be overheated and ruined.

Inspect cover and body. If cracked or damaged, replace.

Only genuine Bendix service parts should be used for replacement.

ASSEMBLY

SL-3™ SWITCH (Figure 1)

1. Insert terminal screws (2) in the cover (1), making sure the terminal connector (7) is properly positioned.
2. Secure terminal screws with washers and nuts, or terminal clips, as the case may be.
3. Place diaphragm (6) in the body.
4. Position the contact plunger (4) on diaphragm.
5. Position spring (3) on the plunger.
6. Place washer (5) on the diaphragm and screw the cover (1) into the body. Torque to 30 foot pounds. Make certain the vent hole in the cover is open.

SL-4™ SWITCH (Figure 2)

1. Position terminal screws (9) in the cover (8) and secure with washers and nuts or terminal clips. Place the vent plug (10) in cover.
2. Place o-ring diaphragm (14) and piston (13) in the body. The o-ring diaphragm should be installed with its flat side adjacent to the piston.
3. Place the gasket (15) in place on the body and contact strip (12) on the piston (13).
4. Position cover assembly on the gasket and secure with machine screws. Torque to 20 inch pounds.

TEST OF REBUILT STOP LIGHT SWITCH

Both operating and leakage tests, as indicated under section entitled "Testing for Serviceability", must be made after rebuilding or repairing the stop light switch. The switch must meet the following specifications:

1. No leakage is permissible at the stop light switch with the brakes applied.
2. The stop light switch contact should close with not more than 7 pounds of air pressure.

GENERAL SAFETY GUIDELINES

WARNING! PLEASE READ AND FOLLOW THESE INSTRUCTIONS TO AVOID PERSONAL INJURY OR DEATH:

When working on or around a vehicle, the following general precautions should be observed at all times.

1. Park the vehicle on a level surface, apply the parking brakes, and always block the wheels. Always wear safety glasses.
2. Stop the engine and remove ignition key when working under or around the vehicle. When working in the engine compartment, the engine should be shut off and the ignition key should be removed. Where circumstances require that the engine be in operation, **EXTREME CAUTION** should be used to prevent personal injury resulting from contact with moving, rotating, leaking, heated or electrically charged components.
3. Do not attempt to install, remove, disassemble or assemble a component until you have read and thoroughly understand the recommended procedures. Use only the proper tools and observe all precautions pertaining to use of those tools.
4. If the work is being performed on the vehicle's air brake system, or any auxiliary pressurized air systems, make certain to drain the air pressure from all reservoirs before beginning **ANY** work on the vehicle. If the vehicle is equipped with a Bendix® AD-IS® air dryer system or a dryer reservoir module, be sure to drain the purge reservoir.
5. Following the vehicle manufacturer's recommended procedures, deactivate the electrical system in a manner that safely removes all electrical power from the vehicle.
6. Never exceed manufacturer's recommended pressures.
7. Never connect or disconnect a hose or line containing pressure; it may whip. Never remove a component or plug unless you are certain all system pressure has been depleted.
8. Use only genuine Bendix® brand replacement parts, components and kits. Replacement hardware, tubing, hose, fittings, etc. must be of equivalent size, type and strength as original equipment and be designed specifically for such applications and systems.
9. Components with stripped threads or damaged parts should be replaced rather than repaired. Do not attempt repairs requiring machining or welding unless specifically stated and approved by the vehicle and component manufacturer.
10. Prior to returning the vehicle to service, make certain all components and systems are restored to their proper operating condition.
11. For vehicles with Automatic Traction Control (ATC), the ATC function must be disabled (ATC indicator lamp should be ON) prior to performing any vehicle maintenance where one or more wheels on a drive axle are lifted off the ground and moving.

