



Service Data

SD-08-2433

Bendix® AD-9si™ and AD-9si™ PuraGuard® Oil Coalescing Air Dryer

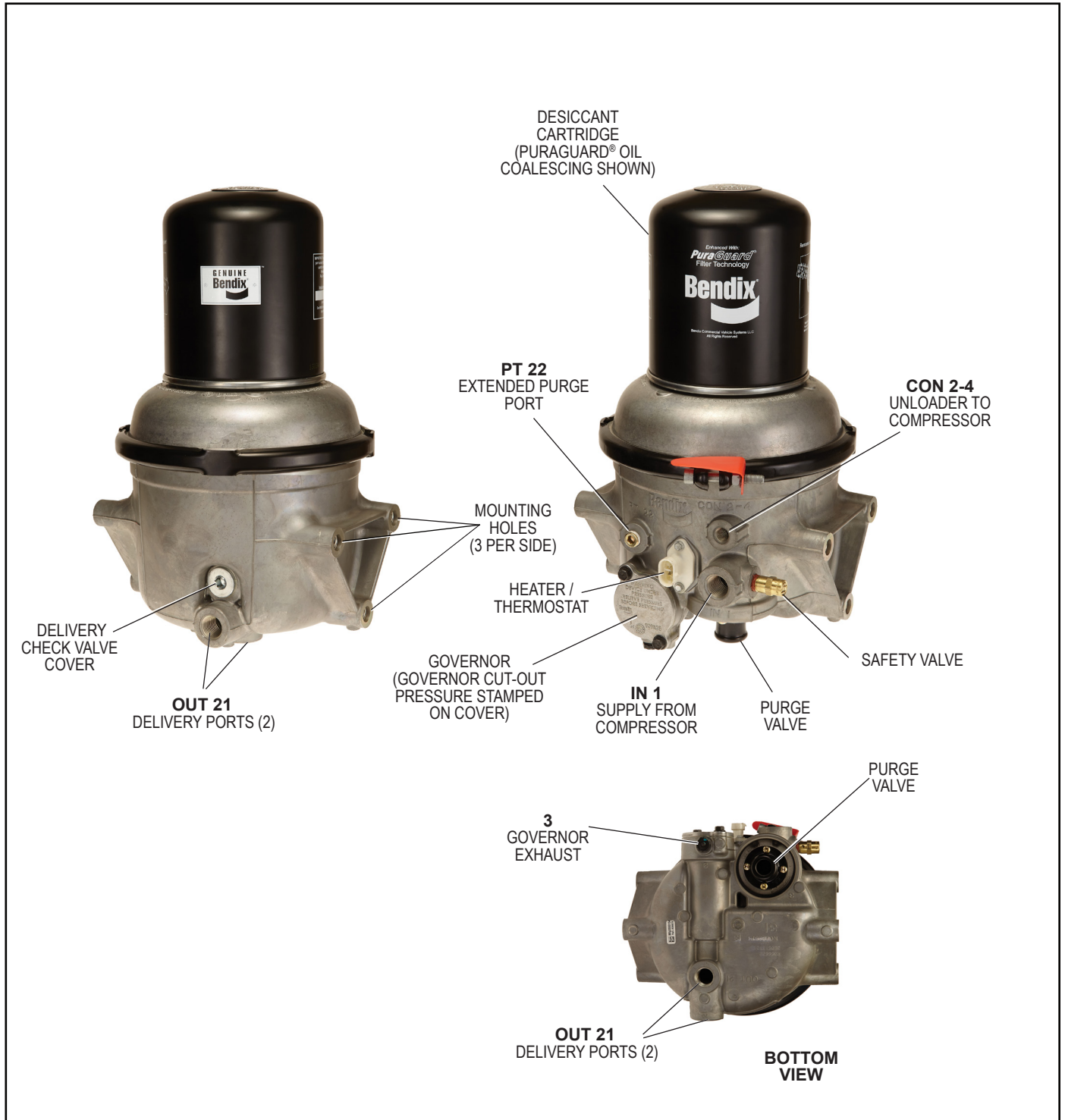

FIGURE 1 - BENDIX® AD-9si™ AND AD-9si™ PURAGUARD® OIL COALESCING AIR DRYER

GENERAL SAFETY GUIDELINES



WARNING! PLEASE READ AND FOLLOW THESE INSTRUCTIONS



TO AVOID PERSONAL INJURY OR DEATH:

When working on or around a vehicle, the following guidelines should be observed **AT ALL TIMES**:

- ▲ Park the vehicle on a level surface, apply the parking brakes and always block the wheels. Always wear personal protection equipment.
- ▲ Stop the engine and remove the ignition key when working under or around the vehicle. When working in the engine compartment, the engine should be shut off and the ignition key should be removed. Where circumstances require that the engine be in operation, **EXTREME CAUTION** should be used to prevent personal injury resulting from contact with moving, rotating, leaking, heated or electrically-charged components.
- ▲ Do not attempt to install, remove, disassemble or assemble a component until you have read, and thoroughly understand, the recommended procedures. Use only the proper tools and observe all precautions pertaining to use of those tools.
- ▲ If the work is being performed on the vehicle's air brake system, or any auxiliary pressurized air systems, make certain to drain the air pressure from all reservoirs before beginning ANY work on the vehicle. If the vehicle is equipped with a Bendix® AD-IS® air dryer system, a Bendix® DRM™ dryer reservoir module, or a Bendix® AD-9si™ air dryer, be sure to drain the purge reservoir.
- ▲ Following the vehicle manufacturer's recommended procedures, deactivate the electrical system in a manner that safely removes all electrical power from the vehicle.
- ▲ You should consult the vehicle manufacturer's operating and service manuals, and any related literature, in conjunction with the Guidelines above.
- ▲ Never exceed manufacturer's recommended pressures.
- ▲ Never connect or disconnect a hose or line containing pressure; it may whip. Never remove a component or plug unless you are certain all system pressure has been depleted.
- ▲ Use only genuine Bendix® brand replacement parts, components and kits. Replacement hardware, tubing, hose, fittings, etc. must be of equivalent size, type and strength as original equipment and be designed specifically for such applications and systems.
- ▲ Components with stripped threads or damaged parts should be replaced rather than repaired. Do not attempt repairs requiring machining or welding unless specifically stated and approved by the vehicle and component manufacturer.
- ▲ Prior to returning the vehicle to service, make certain all components and systems are restored to their proper operating condition.
- ▲ For vehicles with Automatic Traction Control (ATC), the ATC function must be disabled (ATC indicator lamp should be ON) prior to performing any vehicle maintenance where one or more wheels on a drive axle are lifted off the ground and moving.
- ▲ The power **MUST** be temporarily disconnected from the radar sensor whenever any tests **USING A DYNAMOMETER** are conducted on a Bendix® Wingman® Advanced™-equipped vehicle.

DESCRIPTION

The function of both the Bendix® AD-9si™ air dryer and the Bendix® AD-9si™ PuraGuard® oil coalescing air dryer is to collect and remove air system contaminants in solid, liquid, and aerosol form before they enter the brake system. The AD-9si includes a spin-on style cartridge for easy servicing, and most include a fully integrated governor to control air system charging.

The air dryer provides clean, dry air to the components of the brake system, which increases the life of the system and reduces maintenance costs. The need for daily manual draining of the reservoirs is eliminated.

The Bendix AD-9si PuraGuard oil coalescing air dryer has an identical appearance to the standard Bendix AD-9si air dryer, but contains a coalescing media at the inlet of the desiccant bed. This coalescing media provides a higher level of oil removal over the standard AD-9si air dryer. The AD-9si PuraGuard oil coalescing air dryer has all of the same functions as the standard AD-9si air dryer and is used in applications where lower oil concentration levels are required.

IMPORTANT! When servicing, note that standard AD-9si air dryers or air dryer cartridges may be serviced with PuraGuard oil coalescing air dryers or cartridges, however, PuraGuard oil coalescing air dryers or cartridges **MUST** only be serviced with like replacements.

Note: Unless otherwise stated in this document, AD-9si air dryer refers to both the standard and PuraGuard oil coalescing air dryer.

The AD-9si air dryer consists of a “spin on” desiccant cartridge secured to a base assembly. The base assembly contains a delivery check valve assembly, safety valve, heater and thermostat assembly, integrated governor (in most assemblies), threaded air connections, internal purge volume, and purge valve assembly.

The removable purge valve assembly incorporates the purge valve mechanism and a turbocharger cut-off feature that is designed to prevent loss of engine “turbo” boost pressure during the purge cycle of the AD-9si air dryer. For ease of maintenance, all replaceable assemblies should be serviceable without removal of the air dryer from its mounting on the vehicle — provided adequate clearance exists between the air dryer and the vehicle components. Refer to the *Preventive Maintenance* section of this document.

BENDIX AD-9si AIR DRYER OPERATION: GENERAL (Refer to Figures 2 through 5.)

The Bendix AD-9si air dryer is designed to receive compressed air from the vehicle air compressor, clean and dry the air, deliver air to the vehicle’s air reservoirs and control the compressor/dryer charge cycle. The AD-9si air dryer is available with an internal governor (Figures 2 and 3) or without an internal governor (Figures 4 and 5).

AIR DRYER OPERATION: GENERAL

The Bendix AD-9si air dryer alternates between two modes or “cycles” during operation: the Charge Cycle and the Purge Cycle. The following describes these “cycles” of operation.

Air Connection Port ID	Function/ Connection	Quantity
IN 1	Inlet Port (air in)	1
OUT 21	Delivery Port Out	2
PT 22	Extended Purge	1
CON 2-4	Governor Unloader	1
3	Governor Exhaust	1

TABLE 1 - PORT DESIGNATIONS

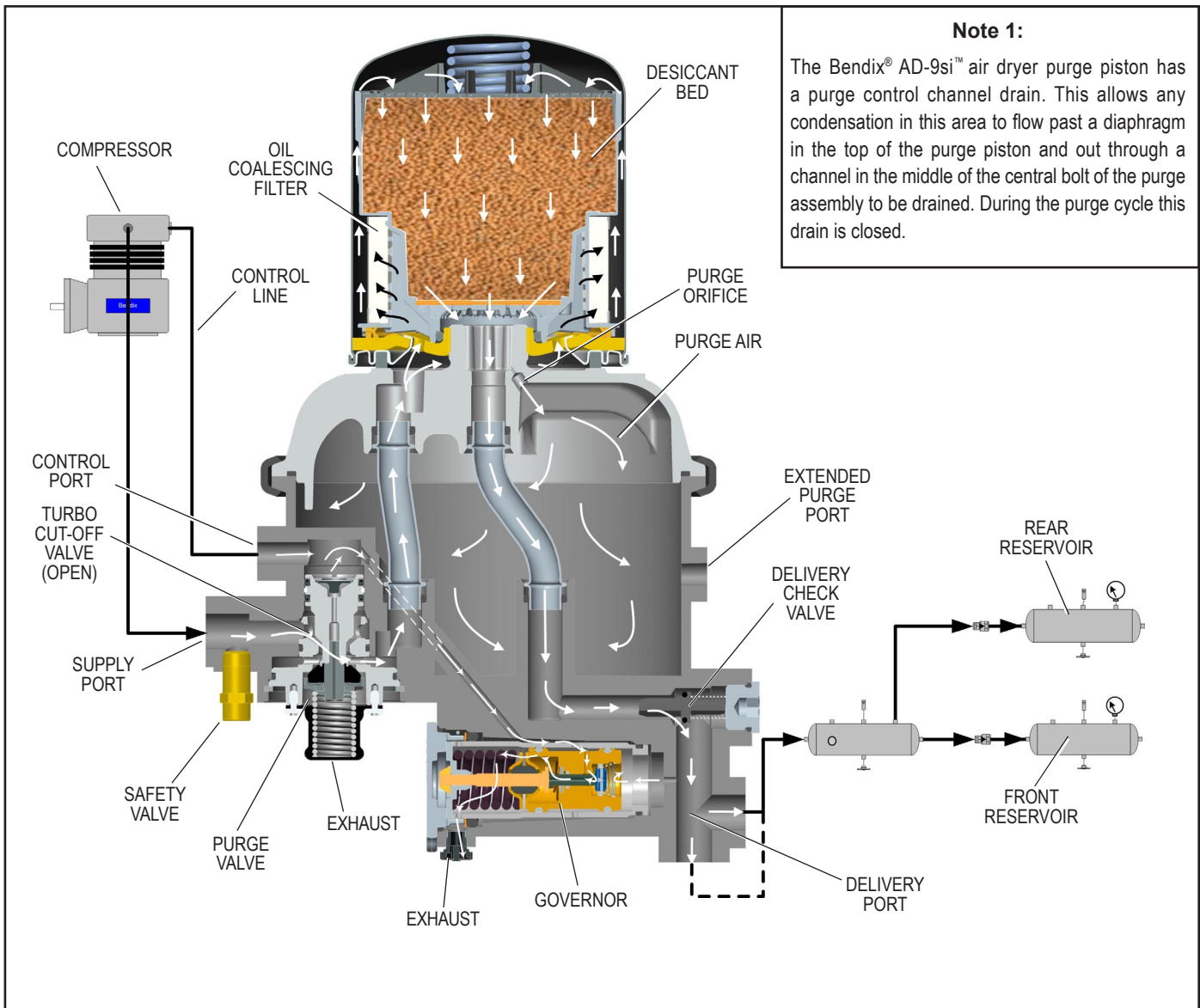

FIGURE 2 - BENDIX® AD-9si™ AIR DRYER WITH GOVERNOR—CHARGE CYCLE

CHARGE CYCLE (Refer to Figures 2 and 4)

When the compressor is running loaded (compressing air), compressed air flows through the compressor discharge line to the inlet (IN 1) port of the air dryer body. The compressed air often includes contaminants such as oil, oil vapor, water and water vapor.

Traveling through the discharge line and into the air dryer, the temperature of the compressed air falls, causing some of the contaminants to condense and drop to the bottom of the air dryer and purge valve assembly. These contaminants are ready to be expelled at the next purge cycle. The air then flows through the inlet tube and into the desiccant cartridge, where it flows through an oil separator — or coalescing filter if equipped with a Bendix® PuraGuard® oil coalescing cartridge — which removes water in liquid form as well as liquid oil and solid contaminants.

Air then flows into the desiccant drying bed and becomes progressively more dry as water vapor adheres to the desiccant material in a process known as adsorption.

Dry air exits the desiccant cartridge, through the outlet tube, then flows to the delivery check valve. Some air exiting the desiccant cartridge is diverted through the orifice into the purge volume area. The delivery check valve opens, supplying air to the two delivery ports. The purge reservoir fills, storing air that will be used to regenerate the desiccant during the purge cycle.

The air dryer will remain in the charge cycle until the air brake system pressure builds to the governor cut-out setting of approximately 130 psi.

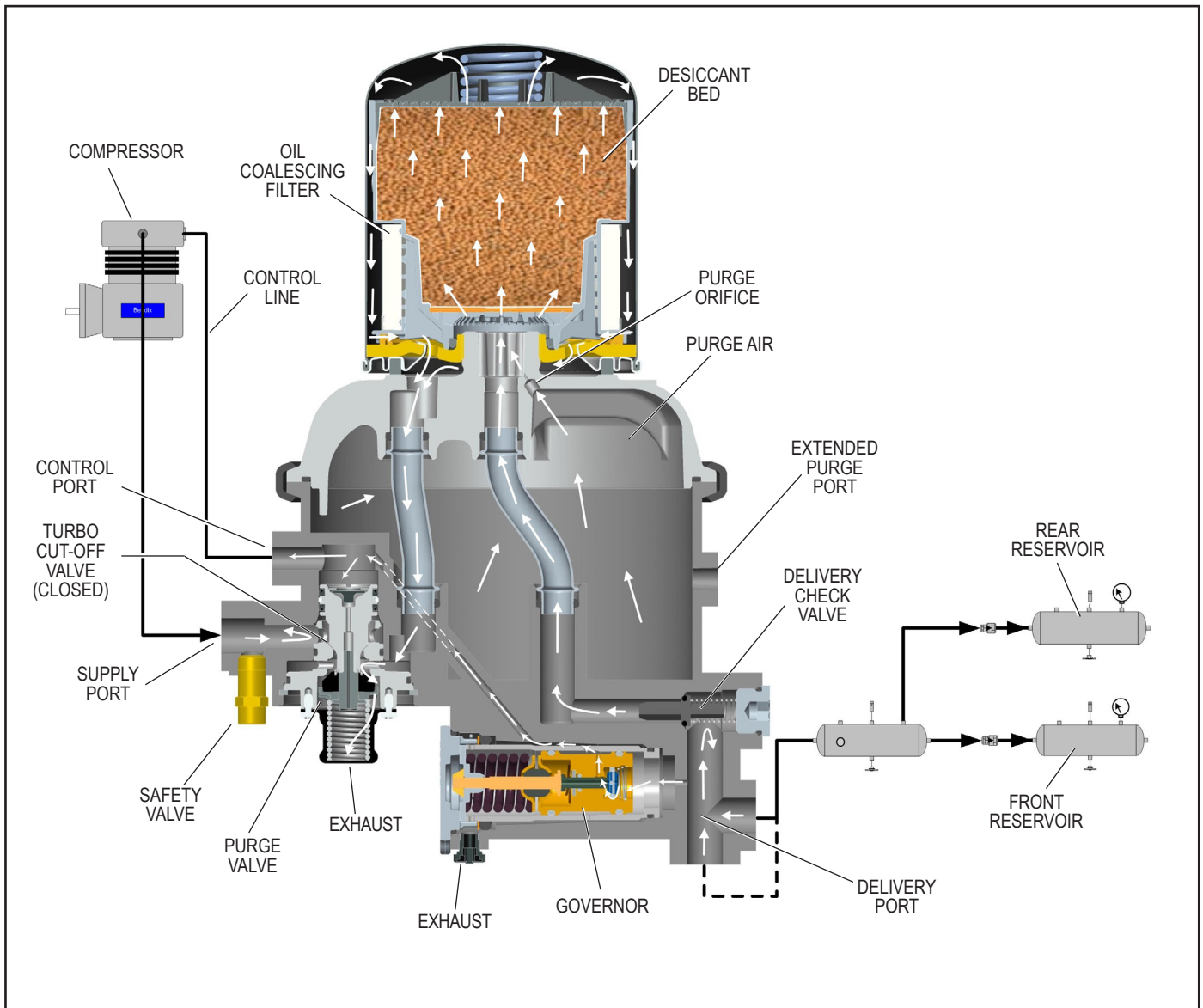

FIGURE 3 - BENDIX® AD-9si™ AIR DRYER WITH GOVERNOR—PURGE CYCLE

PURGE CYCLE (Refer to Figures 3 and 5)

When air brake system pressure reaches the cut-out setting of the governor, the integral governor unloads the compressor by supplying a pressure signal through the control port (CON 2-4). This signal activates the purge cycle of the air dryer.

The governor unloads the compressor by allowing air pressure to fill the line leading to the compressor unloader mechanism. This suspends the delivery of compressed air to the Bendix® AD-9si™ air dryer.

Similarly, the governor also supplies this air pressure signal to the purge valve. The pressure moves the air dryer purge piston down, opening the purge valve to atmosphere and closing off the compressor air supply to the turbo cut-off

valve (described in the "Turbo Cut-off Feature" section of this document). Water and contaminants captured are expelled immediately when the purge valve opens. In addition, air — which was flowing through the desiccant cartridge — changes direction and begins to flow from the purge volume toward the open purge valve. Contaminants collected by the air dryer filters and desiccant are removed by air flowing from the purge volume through the desiccant drying bed to the open purge valve.

The initial purge and desiccant cartridge decompression lasts only a few seconds, evidenced by an audible burst of air at the air dryer exhaust.

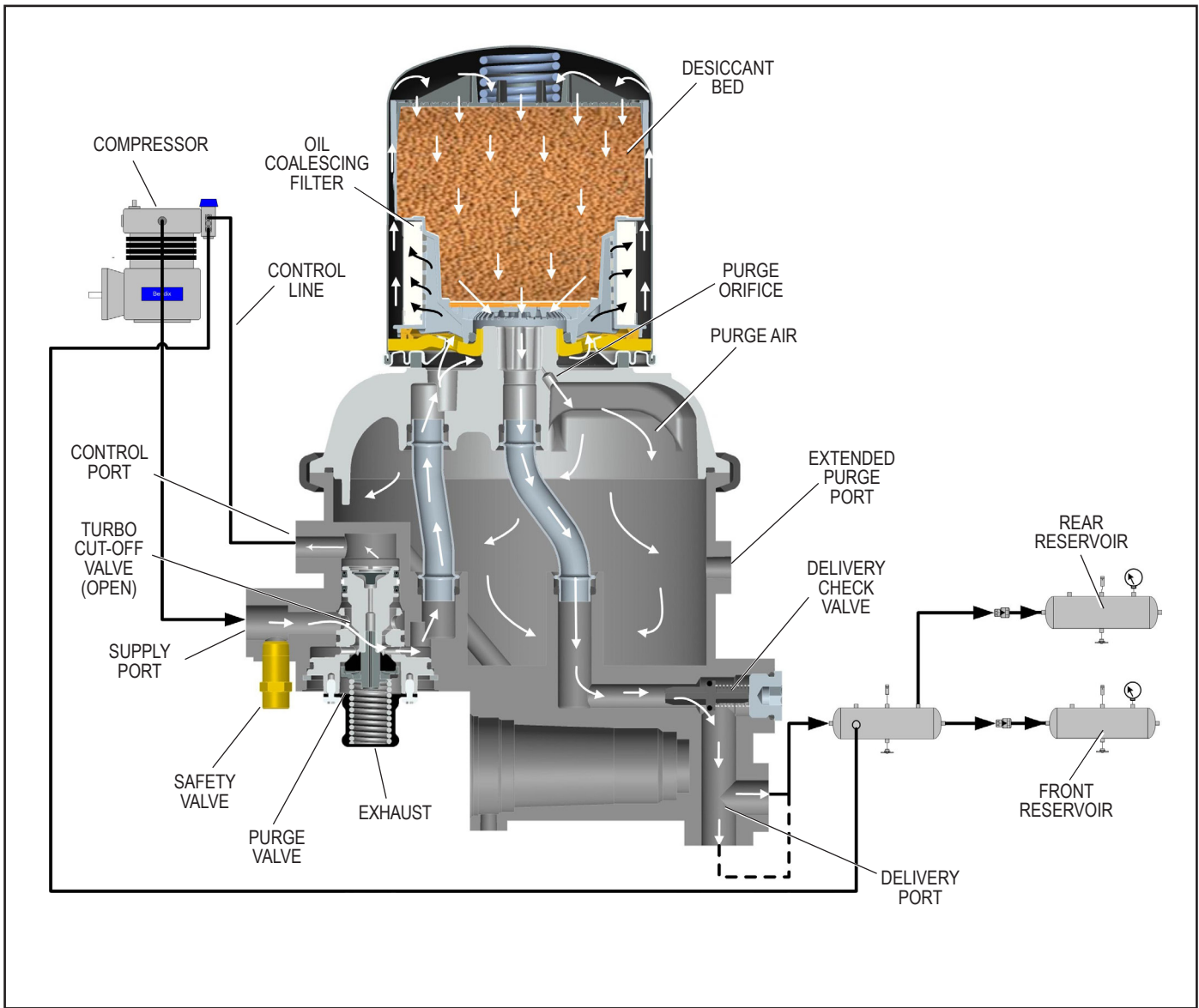

FIGURE 4 - BENDIX® AD-9si™ AIR DRYER WITHOUT GOVERNOR—CHARGE CYCLE

The actual regeneration of the desiccant drying bed begins as dry air from the purge volume flows through the purge orifice into the desiccant bed. Pressurized air from the purge volume expands after passing through the purge orifice; its pressure lowers and its volume increases. The flow of dry air through the drying bed regenerates the desiccant material by removing any water vapor adhering to it. Approximately 40 seconds are required for the entire contents of the purge volume of a Bendix® AD-9si™ air dryer to flow through the desiccant drying bed. This time will increase if the dryer is fitted with an extended purge reservoir.

The delivery check valve assembly prevents air pressure in the brake system from returning to the air dryer during the purge cycle. After the purge cycle is complete, the air dryer is ready for the next charge cycle to begin.

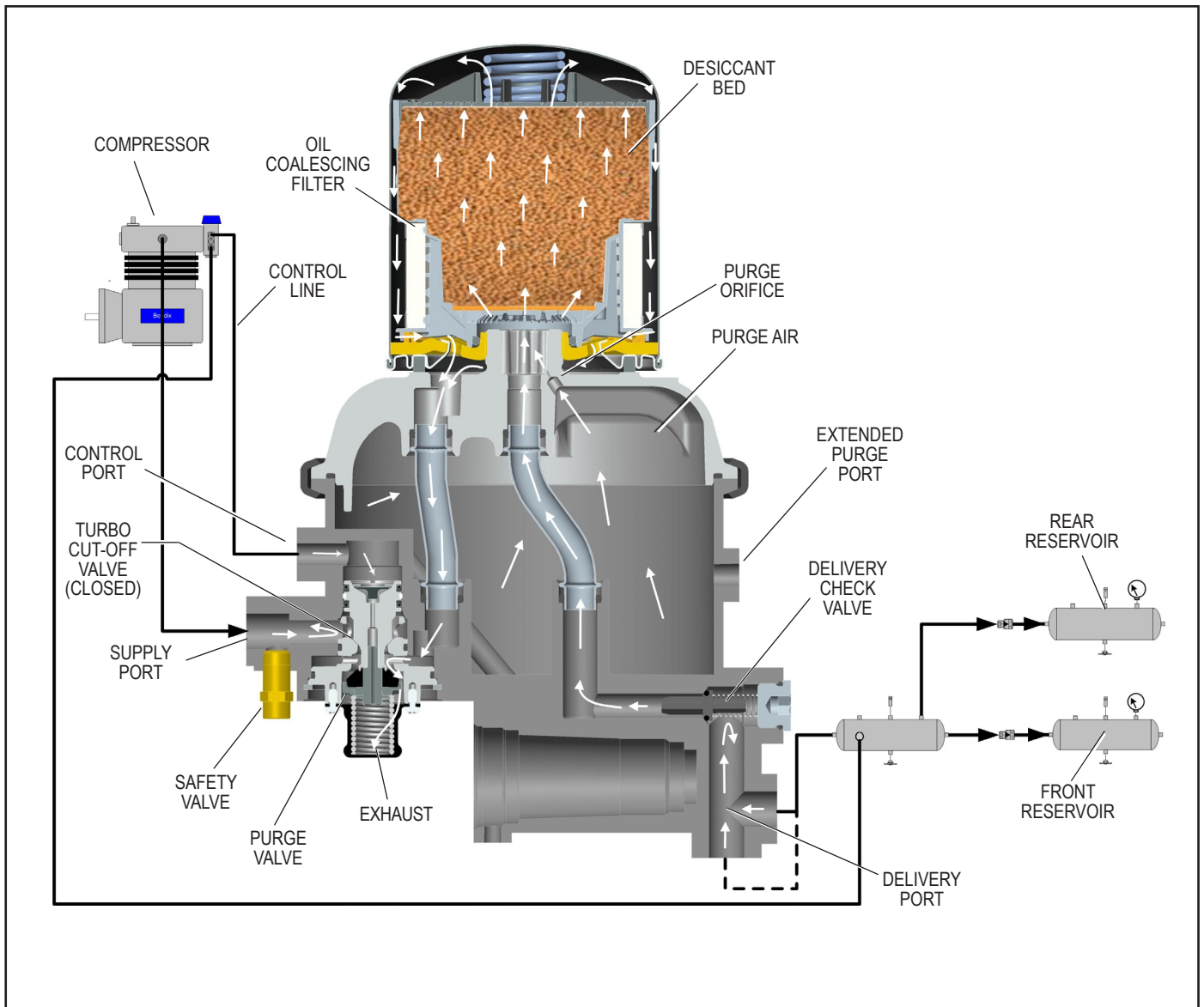

FIGURE 5 - BENDIX® AD-9si™ AIR DRYER WITHOUT GOVERNOR—PURGE CYCLE

TURBO CUT-OFF FEATURE (Refer to Figures 3 and 5)

The primary function of the turbo cut-off valve is to prevent loss of engine turbocharger air pressure through the Bendix® AD-9si™ air dryer when the dryer is in the purge mode.

At the onset of the purge cycle, the downward travel of the purge piston is stopped when the turbo cut-off valve (the tapered portion of the purge piston) contacts its mating

metal seat in the purge valve housing. With the turbo cut-off valve seated (in the closed position), air in the compressor discharge line — as well as the AD-9si air dryer inlet port — cannot enter the air dryer. By completing these actions, the turbo cut-off effectively maintains turbocharger boost pressure to the engine.

PREVENTIVE MAINTENANCE

Important: Review the warranty policy before performing any intrusive maintenance procedures. An extended warranty may be voided if intrusive maintenance is performed during this period. Purge valve and governor maintenance is permissible during the warranty period only when using a genuine Bendix® AD-9si™ purge valve governor kit.

Because no two vehicles operate under identical conditions, maintenance and maintenance intervals will vary. Experience is a valuable guide in determining the best maintenance interval for any one particular operation.

Every 900 operating hours, or 25,000 miles, or three (3) months:

1. Check for moisture in the air brake system by opening reservoir drain valves and checking for the presence of water. If moisture is present, the desiccant cartridge may require replacement; however, the following conditions can also cause water accumulation and should be considered before replacing the desiccant:
 - A. An outside air source has been used to charge the system. This air did not pass through the drying bed of the air dryer.
 - B. Air usage is exceptionally high and not normal for a highway vehicle.

This may be due to accessory air demands or some unusual air requirement that does not allow the compressor to load and unload (compressing and non-compressing cycle) in a normal fashion. Check for high air system leakage. If the vehicle vocation has changed, it may be necessary to upgrade the compressor size. Contact the Bendix TechTeam at 1-800-AIR-BRAKE (1-800-247-2725), option 2, or www.bendix.com for more information.
 - C. The location of the air dryer is too close to the air compressor. See the troubleshooting chart at the end of this document (Symptom 2 - Remedy A).
 - D. In areas where more than a 30° range of temperature occurs in one day, small amounts of water can temporarily accumulate in the air brake system due to condensation. Under these conditions, the presence of small amounts of moisture is normal.

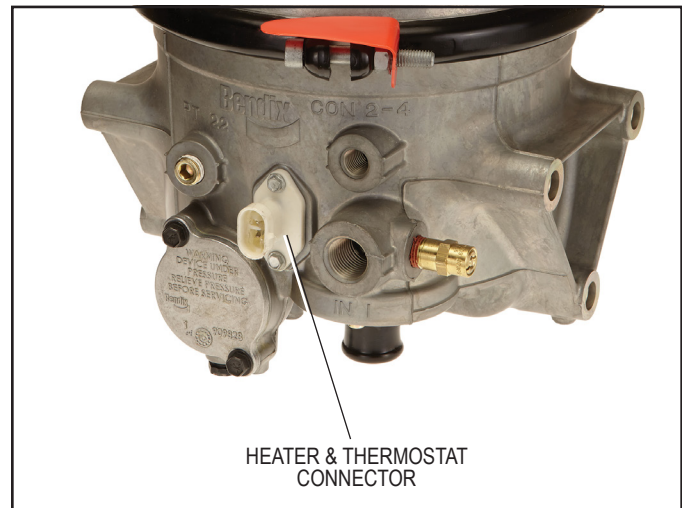

FIGURE 6 - HEATER AND THERMOSTAT CONNECTOR

For Bendix AD-9si air dryers: Preventive Maintenance is as easy as 1-2-3

Adhering to a preventive maintenance schedule is crucial to keeping a vehicle's air system clean and ensuring superior performance of all components that utilize system air— such as brakes, emissions equipment and automated manual transmissions. Depending on vocation, Bendix recommends a 1-, 2- or 3-year air dryer cartridge replacement on vehicles equipped with a Bendix® compressor.

For severe service application — such as residential refuse trucks or school buses — the air dryer cartridge should be replaced every year or 100,000 miles; for pick-up and delivery operations, or for double- and triple-trailer line haul trucks, every two years or 200,000 miles is the recommendation. Line-haul operations using a single trailer should swap the filter out every three (3) years or 300,000 miles. The recommended intervals for trucks equipped with non-Bendix compressors are six months (50,000 miles), one year (100,000 miles), and two years (200,000 miles), respectively.

More frequent intervals may be required depending on a vehicle's age, its compressor condition, use of a non-Bendix compressor, the operating environment, the vehicle's vocation, and its usage. In conjunction with these guidelines, fleets can determine the functionality of their filters by checking for moisture in the air brake system monthly. If moisture is present, the air dryer cartridge may require replacement. Reference the Bendix Service Data Sheet of the specific air dryer for additional information. (Recommended intervals for trucks equipped with non-Bendix compressors are six months (50,000 miles), one year (100,000 miles), and two years (200,000 miles), respectively.)

1. Visually check for physical damage, such as chafed or broken air and electrical lines, and broken or missing parts.
2. Check the Bendix® AD-9si™ air dryer and mounting bolts for tightness. See *Figure 1*. Re-torque the three air dryer bolts to 720–912 in-lbs.
3. Perform the Operation & Leakage Tests listed in this publication.
5. Check the operation of the air dryer heater and thermostat assembly during cold weather operation as follows:
 - A. Electric Power to the Dryer (Refer to Figure 4)

With the ignition or engine kill switch in the RUN position, check for voltage to the Heater and Thermostat assembly using a voltmeter or test light. Unplug the electrical connector at the air dryer and place the test leads on each of the connections of the female connector on the vehicle power lead. If there is no voltage, look for a blown fuse, broken wires, or corrosion in the vehicle wiring harness. Check to see if a good ground path exists.
 - B. Thermostat and Heater Operation

Note: *These tests are not possible except in cold weather operation.*

Turn off the ignition switch and cool the Heater and Thermostat assembly to below 40° Fahrenheit. Using an ohmmeter, check the resistance between the electrical pins in the air dryer connector half. The resistance should be 1.5 to 3.0 ohms for the 12 volt heater assembly, and 6.0 to 9.0 ohms for the 24 volt heater assembly.

Warm the Heater and Thermostat assembly to approximately 90° Fahrenheit and again check the resistance. The resistance should exceed 1000 ohms. If the resistance values obtained are within the stated limits, the thermostat and heater assembly is operating properly. If the resistance values obtained are outside the stated limits, replace the heater and thermostat assembly.



1. **This air dryer is intended to remove moisture and other contaminants normally found in the air brake system. Do not inject alcohol, anti-freeze, or other de-icing substances into — or upstream of — the air dryer. Alcohol is removed by the dryer, but reduces the effectiveness of the device to dry air. Use of these or other substances can damage the air dryer and may void the warranty.**
2. **For the Bendix AD-9si air dryer, there are no serviceable components or maintenance requirements that require the removal of the clamp band.**

OPERATION & LEAKAGE TESTS (REFER TO THE TROUBLESHOOTING CHART IN THIS MANUAL)

1. Check all lines and fittings leading to and from the air dryer for leakage and integrity. Repair any leaks found.
2. Build up system pressure to governor cut-out and note that the Bendix AD-9si air dryer purges with an audible escape of air. Watch the system pressure and note the pressure fall-off for a ten minute period. If pressure drop exceeds— a) for a single vehicle: 1 psi/minute from either service reservoir; or b) for tractor trailer: 3 psi/minute from either service reservoir—inspect the vehicle air systems for leak sources and repair them. Refer to the Symptoms 1 and 4 in the *Troubleshooting Chart*.
3. **CAUTION: Be sure to wear safety glasses in case of a purge blast.** Check for excessive leakage around the purge valve with the compressor in the charge mode (compressing air). Apply a soap solution to the purge valve exhaust port and observe that leakage does not exceed a 1" bubble in one second. If any leakage exceeds the maximum specified, refer to Symptom 4 in the *Troubleshooting Chart*.
4. Build up system pressure to governor cut-out and note that the AD-9si air dryer purges with an audible burst of air, followed immediately by approximately 40 seconds of air flowing out of the purge valve. Apply and release the service brakes several times to reduce system air pressure to governor cut-in. Note that the system once again builds to full pressure and is followed by a purge. If the system does not follow this pattern, refer to Symptoms 5 and 6 in the *Troubleshooting Chart*.

GENERAL

When rebuilding or replacing components of the air dryer and reservoir, use only genuine Bendix® brand replacement parts. For ease in servicing, the AD-9si air dryer has been designed so that maintenance kits can be installed without removing the air dryer from the vehicle. **CAUTION: Always depressurize the air dryer and purge volume by slowly removing the plug in port 22—and drain all other reservoirs on the vehicle—to 0 psi before servicing the air dryer.**

If—after completing the routine operation and leakage tests—it has been determined that one or more components of the air dryer requires replacement or maintenance, refer to the *Maintenance Kit listing shown in this manual or the Bendix® Quick Reference Catalog for the appropriate kit(s)*. The *Quick Reference Catalog (BW1114)* can be ordered and viewed on line at www.bendix.com.

Note: *Kits are not available for servicing components inside the air dryer purge volume.*



WARNING

DO NOT ATTEMPT TO REMOVE THE CLAMP BAND THAT RETAINS THE TWO HOUSINGS TOGETHER. SERIOUS INJURY OR DEATH MAY OCCUR IF THESE INSTRUCTIONS ARE NOT FOLLOWED COMPLETELY.

BENDIX® AD-9si™ AIR DRYER REMOVAL

This air dryer removal process is presented in the event it becomes necessary to replace the entire air dryer. Normal service and parts replacement does not require removal of the air dryer from the vehicle.

1. Park the vehicle on a level surface and prevent movement by means other than the brakes.
2. Drain all reservoirs to 0 psi.
3. Identify and disconnect the three air lines from the air dryer housing.
4. Unplug the vehicle wiring harness from the heater and thermostat assembly connector.
5. Remove the three mounting bolts that secure the air dryer to the vehicle.

BENDIX AD-9si AIR DRYER INSTALLATION

1. Install the Bendix® AD-9si™ air dryer on the vehicle using the three existing 1/2"-13 UNC bolts. Torque the bolts to 720-912 in-lbs. If replacement bolts are necessary use grade 5 or above and ensure they are the same length as those originally used to install the dryer. If the original air dryer is being reinstalled make sure the threads in the air dryer housing are in good condition.
2. Reconnect the three air lines to the proper ports on the air dryer—identified during step 3 of the Bendix AD-9si removal.
3. Reconnect the vehicle wiring harness to the AD-9si air dryer heater and thermostat assembly connector by plugging it into the air dryer connector until its lock tab snaps in place.
4. Before placing the vehicle back into service test the air dryer operation as indicated in *Testing The Bendix AD-9si Air Dryer* section that follows.

TESTING THE BENDIX AD-9si AIR DRYER

Before placing the vehicle into service, perform the following tests:

1. Close all reservoir drain valves.
2. Build up system pressure to governor cut-out and note that the Bendix AD-9si air dryer purges (with an audible burst of air), followed immediately by approximately 40 seconds of air flowing out of the purge valve.

Bendix® AD-9si™ Maintenance Kits		
Kit Description	Piece No.	
Delivery Check Valve Replacement Kit	K092011	
Desiccant Cartridge Replacement Kit (Standard)	5008414	
Desiccant Cartridge Replacement Kit - Bendix AD-9si PuraGuard® air dryer (can be used to replace the standard cartridge)	5008414PG	
Governor Kit	K092010	
Heater & Thermostat Replacement (12 volt)	109578	
Heater & Thermostat Replacement (24 volt)	109579	
Safety Valve Replacement	800155	
Silencer Kit (not shown)	K021189	
Wiring Harness & Splice Kit (not shown)	109871N	
Extended Purge Kits (not shown)		
93 in ³ Reservoir w/ 3/8"-16 U-bolts	5012561N	
93 in ³ Reservoir w/ 1/2"-13 U-bolts	5005309N	
288 in ³ Reservoir w/ 3/8"-16 U-bolts	5008972	
Purge Valve Assembly		
Type	Configuration	Service Kit Pc. No.
Purge Valve Assembly for climate conditions above -40°C (-40°F)	Bendix® AD-9si™ Air Dryer	K022105
	AD-9si™ Air Dryer (Soft Seat Version)	K031560
	AD-9si™ Air Dryer (Discharge Line Unloader)	K031562
Arctic Purge Valve Assembly for climate conditions of -40°C to -50°C (-40°F to -58°F)	AD-9si Air Dryer	K031559
	AD-9si Air Dryer (Soft Seat Version)	K031561
	AD-9si Air Dryer (Discharge Line Unloader)	K031563

3. Apply and release the service brakes several times to reduce system air pressure to governor cut-in. Note that the system once again builds to full pressure and is followed by a purge at the air dryer exhaust.
4. It is recommended that the total air system be tested for leakage to ensure that the AD-9si air dryer will not cycle excessively.



WARNING

It is important to read and adhere to the following instruction, to ensure the brake system operates safely after bypassing the air dryer.

TEMPORARY AIR DRYER BYPASS

To temporarily bypass the air dryer, follow these procedures and be sure to adhere to the General Safety Guidelines outlined elsewhere in this document.

Make sure that all residual pressure has been released. Slowly loosen the fitting that connects the air compressor discharge line to the air dryer inlet port (IN 1) thereby allowing any pressure trapped in the air dryer purge reservoir to escape to the atmosphere. Once the pressure has escaped and air flow has ceased, remove the fitting

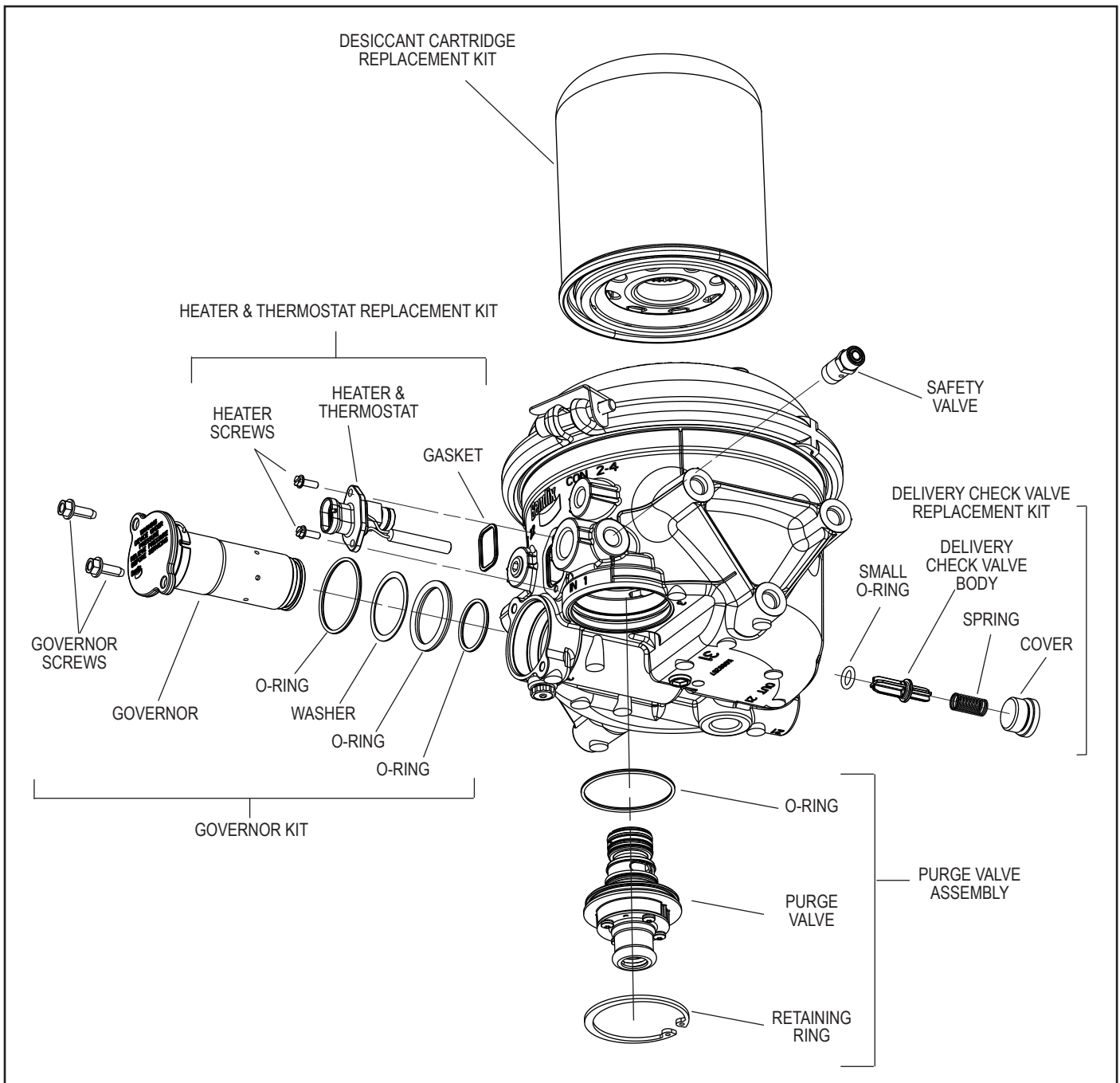

FIGURE 7 - BENDIX® AD-9si™ AIR DRYER SERVICEABLE COMPONENTS

that connects the air compressor discharge line to the air dryer inlet fitting. Remove the air dryer delivery port fitting (OUT 21). Using any necessary fittings, install a Tee fitting in the air dryer delivery port. To one side of the Tee fitting install the line removed from the air dryer delivery port, to the opposite side of the Tee fitting install the line removed from the air dryer inlet port. This procedure will allow the integral governor to continue to regulate the air brake system pressure properly.

After testing the Tee fitting for any air leakage — by using a soap solution after charging to system cut-out pressure (a 1" bubble in 10 seconds is acceptable) — the vehicle may be returned to temporary service.

Note: This is a temporary bypass of the air dryer. Full repair of the unit must be carried out at the earliest opportunity. Excessive vehicle operation with the air dryer bypassed may damage oil sensitive components such as an automated manual transmission or the emission system. With the air dryer removed from the system, contaminants will be entering the air brake system. Reservoirs will need to be manually drained daily until the repairs are completed. At the end of each working day, park the vehicle and slowly drain pressure through the drain valves — leave open to the atmosphere — for several hours, if possible. When repairs are carried out, be sure to check that all reservoirs are emptied of all contaminants.

If, after bypassing the air dryer, the system pressure still does not build, use the following procedure to remove, clean, and reinstall the delivery check valve.

DELIVERY CHECK VALVE CLEANING PROCEDURE

(Note: This is only required if system pressure does not build after temporary bypass is completed.)

Refer to Figure 7 throughout the following procedure. De-pressurize the air brake system following the general safety precautions outlined elsewhere in this document. Also, always de-pressurize the air dryer purge reservoir before servicing the air dryer by slowly loosening the fitting that connects the air compressor discharge line to the air dryer inlet port.

This procedure does not require removal of the Bendix® AD-9si™ air dryer from the vehicle.

1. Remove the delivery check valve cover, located directly above the delivery port (OUT 21).
2. The spring/delivery check valve can now be removed.
3. Remove and retain the o-ring from the check valve body.

CLEANING & INSPECTION

1. Use a suitable solvent to clean all metal parts, and use a cotton swab to clean the bore (**Note: Do not use abrasives or tools to clean the bore: any scratches caused may necessitate replacing the Bendix AD-9si air dryer.**) Superficial external corrosion and/or pitting is acceptable.
2. Clean the o-rings with a clean dry cloth. Do not use solvents.
3. Inspect for physical damage to the bore and the check valve seat. If the bore is damaged (by scratches etc. that would prevent the delivery check valve from seating), replace the AD-9si air dryer.
4. Inspect the delivery check valve, o-rings, etc. for wear or damage. Replace, if necessary, using the check valve replacement kit available at any authorized Bendix® parts outlets.

ASSEMBLY

1. Lubricate the smaller o-ring and check valve body with a heavy duty lithium grease.
2. Install the o-ring on the check valve body by sliding the o-ring over the set of four tapered guide lands. The o-ring groove holds the o-ring in its correct location.
3. At the other end of the check valve body, the spring is installed over the set of four straight guide lands. When the spring has been pushed to the correct location, the check valve body is designed to hold the end of the spring in position: be sure that the spring is not loose before continuing with this installation.
4. Install the assembled check valve body/o-ring/spring in the delivery port so that the o-ring rests on its seat and the free end of the spring is visible.
5. Grease the larger o-ring and install it onto the cover.
6. Replace the delivery check valve cover and torque to 720–840 in-lbs.
7. Before placing the vehicle back into service, check to see that the system pressure now builds to full operational pressure.

**BENDIX® AD-9si™ AIR DRYER
TROUBLESHOOTING CHART**

SYMPTOM	CAUSE	REMEDY
<p>1. Dryer is constantly “cycling” or purging.</p>	<p>A. Excessive system leakage.</p>	<p>A. Test for excessive system leakage. Allowable leakage observed at dash gauge: - Single vehicle - 1 psi/minute. - Tractor trailer - 3 psi/minute. Using soap solution, test vehicle for leakage at fittings, drain valves and system valves and any accessories (i.e. air suspension). Repair or replace as necessary and retest the system.</p>
	<p>B. Defective delivery check valve.</p>	<p>B. Build system pressure to governor cut-out. Wait 1 minute for completion of purge cycle. Using soap solution at exhaust of purge valve, leakage should not exceed a 1" bubble in less than 5 seconds.</p> <p>If a rapid loss of pressure is found, the following procedure will determine if the delivery check valve is malfunctioning:</p> <p>Build system pressure to governor cut-out and allow a full minute for the normal dryer purge cycle to empty the purge reservoir. Switch off the engine and apply and release the brakes multiple times so that the system pressure reaches governor cut-in. The purge valve will return to its closed position. Carefully remove the air dryer cartridge using a strap wrench and then test for air leaking through the center of the threaded boss by applying a soap solution to the area. Replace the delivery check valve if there is excessive leakage (exceeding a 1" bubble in 5 seconds).</p> <p>Re-grease the seal on the air dryer cartridge before reinstalling.</p>
	<p>C. Defective governor.</p>	<p>C. Check governor at both “cut-in” and “cut-out” position for proper pressures and excessive leakage at the exhaust.</p>
	<p>D. Compressor unloader mechanism leaking excessively.</p>	<p>D. Remove air strainer, or fitting, from compressor inlet cavity. With compressor unloaded, check for unloader piston leakage. Slight leakage is permissible.</p>

BENDIX® AD-9si™ AIR DRYER TROUBLESHOOTING CHART

SYMPTOM	CAUSE	REMEDY
2. Water in vehicle reservoirs.	A. Maximum air dryer inlet temperature is exceeded due to improper discharge line length.	A. Check for excessive carbon build-up in compressor discharge line. Replace if required. Make certain that discharge line length is at least 6 ft. Increase discharge line length and/or diameter to reduce air dryer inlet temperature.
	B. Ambient temperature exceeds 125°F.	B. Relocate the air dryer away from excessive heat source.
	C. Air system charged from outside air source (outside air not passing through air dryer).	C. If system must have outside air fill provision, outside air should pass through the air dryer.
	D. Excessive air usage - Air dryer not compatible with vehicle air system requirement (improper air dryer/ vehicle application).	D. Refer to the <i>Bendix® Air Dryer Application Guideline</i> (BW2600) for proper application of the Bendix® AD-9si™ air dryer. An extended purge reservoir may be added for higher air usage vehicles, such as city buses and construction vehicles. If the vehicle is equipped with high air usage accessories such as trailer pump-off systems or central tire inflation, the air for these accessories must by-pass the air dryer.
	E. Desiccant requires replacement.	E. Replace desiccant cartridge assembly. See <i>Bendix Air Dryer Application Guideline</i> (BW2600) for recommended service intervals.
	F. Air dryer not purging.	F. Refer to Symptom 6.
	G. Purge (air exhaust) time insufficient due to excessive system leakage.	G. Refer to Symptom 1.
3. Safety valve on air dryer "popping off" or exhausting air.	A. Safety valve setting too low (<150 psi).	A. Replace safety valve.
	B. System pressure too high (>135 psi).	B. Test with accurate gauge. Replace the governor cartridge if necessary.
	C. Excessive pressure pulsations from compressor. (Typical single cylinder type).	C. Increase the volume in the discharge line. This can be accomplished by adding a 90 cubic inch (or larger) reservoir between the compressor and the AD-9si air dryer.
4. Constant exhaust of air at air dryer purge valve exhaust or unable to build system pressure. (Charge mode.)	A. Air dryer purge valve leaking excessively.	A. With compressor loaded, apply soap solution on purge valve exhaust, to test for excessive leakage. Repair or replace purge valve as necessary.
	B. Purge valve frozen open - faulty heater and thermostat, wiring, blown fuse.	B. Refer to paragraph 5 of the <i>Operation and Leakage Tests</i> for heater and thermostat test.
	C. Defective AD-9si™ air dryer delivery check valve.	C. Refer to Symptom 1, Remedy B.
	D. Leaking turbo cut-off valve.	D. Repair or replace purge valve assembly.
	E. Defective governor.	E. Check the governor at both "cut-in" and "cut-out" positions for proper pressures and excessive leakage at the exhaust.
	F. Leaking purge valve control piston seals.	F. Repair or replace purge valve assembly.

BENDIX® AD-9si™ AIR DRYER TROUBLESHOOTING CHART

SYMPTOM	CAUSE	REMEDY
5. Cannot build system air pressure.	A. Supply pressure to the air dryer is not sufficient.	A. Ensure the supply pressure to the air dryer is greater than 110 psi during the system charge.
	B. Kinked or blocked (plugged) discharge line.	B. Check to determine if air passes through discharge line. Check for kinks, bends, excessive carbon deposits, or ice blockage.
	C. Excessive bends in discharge line (water collects and freezes).	C. Discharge line should be constantly sloping from compressor to air dryer with as few bends as possible.
	D. Refer to Symptom 4.	D. Refer to Symptom 4, Remedy A.
	E. Refer to Symptom 7.	E. Refer to Symptom 7, Remedies A and B.
6. Air dryer does not purge or exhaust air.	A. Faulty air dryer purge valve.	A. After determining that air reaches the purge valve piston by installing a Tee fitting with a pressure gauge into the control port, repair purge valve if necessary.
	B. See Causes B, E, and F for Symptom #4.	B. Refer to Symptom 4, Remedies B, E, and F.
7. Desiccant material being expelled from air dryer purge valve exhaust (may look like whitish liquid or paste or small beads.)	A. Faulty dryer cartridge.	A. Replace the Bendix® AD-9si™ air dryer cartridge or AD-9si air dryer.
	B. Excessive dryer vibration.	B. Check the AD-9si air dryer mounting for looseness or damage. Repair mounting and replace cartridge.
8. Unsatisfactory desiccant life.	A. Excessive system leakage.	A. Refer to Symptom 1, Remedy A.
	B. Wrong vehicle application for AD-9si™ air dryer.	B. Refer to Symptom 2, Remedy C.
	C. Compressor passing excessive oil.	C. Check for proper compressor installation; if symptoms persist, replace compressor. Refer to <i>Bendix® Advanced Troubleshooting Guide for Air Brake Compressor (BW1971)</i> .
9. "Pinging" noise excessive during compressor loaded cycle.	A. Single cylinder compressor with high pulse cycles.	A. A slight "pinging" sound may be heard during system build-up when a single cylinder compressor is used. If this sound is deemed objectionable, it can be reduced substantially by increasing the discharge line volume. This can be accomplished by adding a 90 cubic inch (or larger) reservoir between the compressor and the AD-9si air dryer.
10. The air dryer purge piston cycles rapidly in the compressor unloaded (non-compressing) mode.	A. Compressor fails to "unload".	A. Check the air hose from the AD-9si air dryer control port to the compressor for a missing, kinked, or restricted line. Install or repair the air hose. Repair or replace the compressor unloader.



Log-on and Learn from the Best

On-line training that's available when you are – 24/7/365.

Visit www.brake-school.com.