

PARTS AND SERVICE MANUAL

BIL-JAX
A STEP ABOVE®

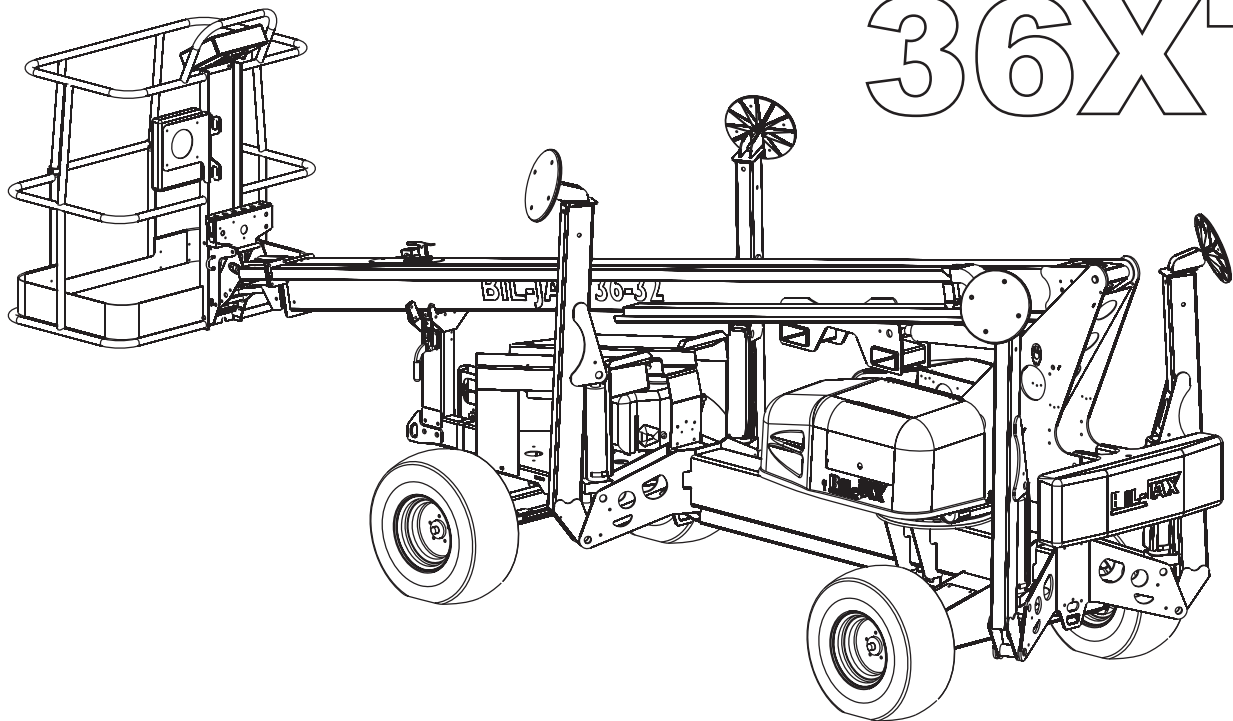

36XT

X-BOOM
AERIAL WORK PLATFORMS™

SELF-PROPELLED AERIAL WORK PLATFORM

This equipment is designed and manufactured in compliance with the duties, responsibilities and standards set forth in the ANSI, CE, CSA and/or AS standards in effect at the time of manufacture.

This equipment will meet or exceed applicable ANSI, CE, CSA and/or AS codes and standards when operated in accordance with manufacturer's recommendations.

It is the responsibility of the user to follow all regional codes and regulations that govern the safe operation of this equipment.

Obtain, read and obey all safety precautions before performing maintenance or repairs or attempting to operate this equipment. This includes all manufacturer recommendations as well as those directives set forth by government and local authorities.

To ensure proper and safe use of this equipment, it is strongly recommended that only trained and authorized personnel attempt to operate and maintain the boom lift.

This manual shall be considered a permanent and necessary component of the machine and shall be kept with the boom lift at all times.

Owners and Lessors should complete a full inspection of all components and perform a test of all functions, including brake functions, before commissioning or reselling the machine. Repair or replace all damaged or malfunctioning components.

Bil-Jax, Inc. is dedicated to the continuous improvement of this and all Bil-Jax products. Therefore, equipment information is subject to change without notice. Direct any questions or concerns regarding errors or discrepancies in this manual to the Bil-Jax Service Department.

Copyright © Bil-Jax, Inc. 2008. All Rights Reserved.

"Bil-Jax" is a registered trademark and "A Step Above" and "X-Boom" are trademarks of Bil-Jax, Inc. Contact Bil-Jax for replacement manuals.



125 Taylor Parkway
Archbold, Ohio 43502

Phone (800) 537-0540
(419) 445-8915

Fax (419) 445-0367

<http://www.biljax.com>

TABLE OF CONTENTS

Table of Contents	1
Illustrations	2
Tables	2
1 Safety	3
Legend: Safety Advisories	4
Before Operation	5
During Operation	5
Maintenance Safety	7
Damaged Equipment Policy	8
2 Specifications	9
Range of Motion	10
Specifications	11
Warranty	12
3 Equipment Maintenance	13
Daily Service Checks	14
Weekly Service Checks	16
Monthly Service Checks	17
Annual Service Checks	18
Structural Inspection	19
Additional Service Information	19
Troubleshooting	20
Error Code Definitions	21
4 Cylinder Replacement	25
Lift Cylinder Replacement	26
Outrigger Cylinder Replacement	27
5 Replacement Decals	29
6 Material Safety Data	35
Appendix: Replacement Parts	39
Ordering Replacement Parts	101

LIST OF ILLUSTRATIONS

Figure 2-1	Range of Motion	10
Figure 3-1	Outrigger Position Switch	14
Figure 3-2	Hydraulic Reservoir	15
Figure 3-3	Wheel Nut Tightening Sequence	17
Figure 3-4	Slew Ring Position Measurement	18
Figure 4-1	Lift Cylinder Replacement	26
Figure 4-2	Outrigger Cylinder Replacement	27
Figure 5-1	Decal Locations	31
Figure 5-2	Decal Locations – CE	33

LIST OF TABLES

Table 1-1	Minimum Safe Approach Distances	5
Table 3-2	Troubleshooting Steps	20
Table 3-3	Error Code Definitions	21
Table 5-1	Replacement Decal Descriptions	30
Table 5-2	Replacement Decal Descriptions – CE	32

1 SAFETY

Proper training is required for the safe operation of any mechanical device. Failure to follow all instructions and safety precautions in this manual and attached to the lift will result in death or personal injury.

Prior to Operation:

- ❑ Read, understand and obey all instructions and safety precautions in this manual and attached to the lift.
- ❑ Read, understand and obey all applicable government regulations.
- ❑ Become familiar with the proper use of all controls.
- ❑ Inexperienced users should receive instruction before attempting to operate or maintain the machine.

The use of intelligence and common sense is the best practice when following any safety policy.

LEGEND: SAFETY ADVISORIES

The following safety advisories are used throughout this manual to indicate specific hazards when operating or maintaining the machine. Read, understand and obey all safety advisories to prevent improper service, damage to equipment, personal injury or death.

DANGER _____

Warns of operation near electrical power sources that could lead to personal injury or death.

WARNING _____

Describes conditions or practices that could lead to personal injury or death.

CAUTION _____

Contains information important in the prevention of errors that could damage machine or components.

NOTE: Contains additional information important for performing a procedure.

BEFORE OPERATION

Ensure the following general safety precautions are followed before operating the articulating boom lift:

ALWAYS inspect the usage area for potential hazards, such as unstable or unlevel surfaces, overhead obstructions and electrically charged wires or conductors. ALWAYS watch for moving vehicles in the operating area.

ALWAYS conduct a thorough inspection of the machine before operation. Check for damaged or worn parts, hydraulic leaks, damaged wiring, loose wiring conductors, damaged outriggers, low tire pressure, uneven tire wear or tire damage. Check for any improperly operating components. NEVER operate equipment if any damage is observed or suspected. Repair damaged or malfunctioning equipment before operation.

ALWAYS wear proper clothing and footwear. Wear protective equipment as required by government regulations. Keep loose clothing, jewelry, gloves and hair away from moving parts.

ALWAYS wear a safety harness and energy-absorbing lanyard, such as a safety harness and lanyard provided by Bil-Jax.

ALWAYS inspect platform floor and outrigger footpads for mud, grease, debris or other foreign material. ALWAYS remove any such material from the equipment before operation.

ALWAYS tag any part of the equipment known or suspected to be damaged or malfunctioning. ALWAYS remove a malfunctioning, damaged or defective machine from service. NEVER operate a machine that has any known or suspected defect.

ALWAYS comply with the instructions found in Safety and/or Service Bulletins distributed by the manufacturer. Bulletins may contain critical procedures that supersede the information contained in manuals.

NEVER operate this equipment while under the influence of drugs or alcohol, while taking prescription medications that may leave the operator drowsy or prone to dizziness, or while feeling ill.

NEVER modify the equipment in any way that would affect its original design or operation.

NEVER deface, modify or obscure any decals or markings on equipment.

NEVER operate the equipment in any way for which it is not intended.

DURING OPERATION

Ensure the following general safety precautions are followed while operating the articulating boom lift:

ALWAYS position lift away from power lines to ensure that no part of the lift can accidentally reach into an unsafe area. This includes full extension of the boom through 700° rotation.

DANGER

This machine is NOT insulated for use near electrical power lines and DOES NOT provide protection from contact with or close proximity to any electrically charged conductor. Operator must maintain safe clearances at all times (3.05 meters minimum) and must always allow for platform movement due to gusty winds. Always contact power company before working near power lines. Assume every power line is live. Power lines can be blown by the wind. Refer to Table 1-1 for minimum safe approach distances between the machine and electrical power lines.

Voltage Range (Phase to Phase)	Minimum Safe Approach Distance	
	(Feet)	(Meters)
0 to 300V	Avoid Contact	
Over 300V to 50KV	10	3.05
Over 50KV to 200KV	15	4.60
Over 200KV to 350KV	20	6.10
Over 350KV to 500KV	25	7.62
Over 500KV to 750KV	35	10.67
Over 750KV to 1000KV	45	13.72

Table 1-1. Minimum Safe Approach Distances

ALWAYS keep away from a machine that is exposed to energized power lines. If the machine contacts energized power lines, NEVER touch or operate the machine until power lines are shut off.

ALWAYS operate only on a firm and level surface. NEVER operate on surfaces that do not support the equipment with its rated load capacity or on surfaces that do not support force exerted by the outriggers during boom operation. Operate only on surfaces that can support a pressure of 1.8 kg/cm² (25 psi) to ensure safe operation.

ALWAYS keep personnel away from potential pinch and shear points and from potential crush hazards as indicated by decals attached to the machine.

ALWAYS keep the safety bar lowered unless personnel are entering or exiting the work platform.

ALWAYS keep personnel and obstructions clear of the machine when repositioning boom or basket.

ALWAYS cordon the area surrounding the outriggers to keep personnel, vehicles and moving equipment away from the machine while in use.

ALWAYS stay clear of overhead obstructions, including wires and cables.

ALWAYS engage boom travel latches before towing trailer.

ALWAYS exercise caution when rotating the boom from the ground control station. ALWAYS watch for personnel inside the radius of the turntable and boom arm when rotating the boom lift from the ground or platform controls.

ALWAYS remove personnel from the boom lift before attempting to free an elevated platform that has become caught or snagged on an adjacent structure or obstacle.

NEVER operate the machine on any surface other than firm and level ground. NEVER operate the machine from a position on truckbeds, trailers, floating vessels or scaffolding without written approval from the manufacturer.

NEVER operate lift functions on slopes exceeding 12.5°.

NEVER allow electrode contact with any part of the machine while welding from the platform. NEVER use the machine as a ground for welding.

NEVER operate without the outriggers fully extended or when the machine is not level.

NEVER position an elevated platform against another object to steady the platform

NEVER override or bypass the manufacturer's safety devices.

NEVER attach a safety harness to an adjacent structure, pole, or to nearby equipment while working from the boom platform.

NEVER raise the outriggers while boom is raised or extended.

NEVER sit, stand or climb on cage bars. ALWAYS keep both feet firmly on the work cage floor when working from an elevated platform.

NEVER attempt to increase the working height with boxes, ladders, stools or any other materials.

NEVER operate this equipment when exposed to high winds, thunderstorms, ice or any weather conditions that would compromise operator safety.

NEVER operate boom lift in conditions where wind speeds exceed 12.5 m/sec (45 km/h or 28 mph). High winds may affect stability and boom operation.

NEVER allow ropes, electric cords, hoses or other equipment to become entangled in the machine while raising or lowering platform.

NEVER exceed the load limits set by the manufacturer. Use only the Material Lifting Hook, supplied as an option and manufactured by Bil-Jax, when lifting materials. Safely stow all tools and equipment.

NEVER exceed load ratings by transferring loads to the lift at elevated heights.

NEVER use the platform to lift a load that exceeds the platform dimensions. NEVER lift a load in such a way that the center of gravity is higher than the top guardrail of the platform.

NEVER modify the platform or carry materials that would increase the surface area of the platform. Increasing the area exposed to the wind may decrease machine stability. NEVER attach overhanging loads when raising or lowering the platform.

NEVER use the boom or platform to push or pull or to lift any part of the machine.

NEVER use the boom or platform to place a load against any structure, materials or equipment.

NEVER climb on the boom.

NEVER leave an elevated platform unattended.

NEVER leave the keys in the boom lift while unattended or not in use.

Drive Safety

ALWAYS maintain an awareness of limited sight and blind spots when operating drive functions.

ALWAYS limit travel speed according to surface conditions, slope, location of personnel and obstructions and any other factors which may result in collision.

NEVER operate drive functions on slopes exceeding 20°.

NEVER engage in stunt driving, horseplay or any other behavior considered unsafe according to employer, job site and/or government regulations.

NEVER operate the internal combustion engine in an area that is not properly ventilated.

NEVER fuel the internal combustion engine while smoking, or while near spark or open flame.

MAINTENANCE SAFETY

Ensure the following general safety precautions are followed while performing maintenance on the articulating boom lift:

General Maintenance

ALWAYS perform maintenance procedures according to manufacturer's guidelines. NEVER disregard or bypass proper maintenance procedures.

ALWAYS inspect hydraulic system to ensure that all lines, connectors and fittings are properly fastened and in good condition.

ALWAYS turn the key switch OFF and remove key before performing maintenance.

ALWAYS perform maintenance with the boom and platform in a fully lowered, stowed position, when possible. ALWAYS secure the boom before performing maintenance on hydraulic cylinders.

ALWAYS disconnect power to the hydraulic pump drive motor before making electrical checks to the hydraulic valves.

ALWAYS keep all mechanical parts properly adjusted and lubricated according to maintenance schedule and manufacturer's specifications.

ALWAYS perform a function check of operating controls before each use and after repairs have been made.

ALWAYS locate and protect against possible pinch points before performing any maintenance or repairs.

ALWAYS use only manufacturer-approved parts to repair or maintain equipment. If any portion of this equipment is rebuilt or repaired, retesting is required in accordance with factory instructions.

ALWAYS maintain a safe distance while testing the hydraulic components. ALWAYS relieve hydraulic pressure before loosening or removing hydraulic components. NEVER test or operate the hydraulic components while personnel are near the equipment.

NEVER allow water or foreign particles into the DC electric motor housing. Inclusion of water or foreign particles may cause serious damage to the motor. If the motor becomes wet, consult an authorized Bil-Jax service technician for proper drying instructions.

NEVER add unauthorized fluids to the hydraulic system or battery. NEVER mix hydraulic oils. Consult manufacturer specifications. Refer to Section 4 for hydraulic system maintenance procedures.

NEVER exceed the manufacturer's recommended relief valve settings.

NEVER touch or allow metal tools to contact any components that are sensitive to static discharge. ALWAYS use static discharge prevention mats and grounding devices when handling electronic components.

NEVER adjust, repair, replace or bypass any hydraulic or electrical control or safety device. These include, but are not limited to, hydraulic load control and flow control valves, solenoid valves and limit switches. ALWAYS consult an authorized Bil-Jax technician if repairs are necessary.

NEVER modify, alter or change the equipment without first consulting an authorized Bil-Jax technician, and NEVER in any way that would affect its original design or operation.

Battery Maintenance

Ensure the following general safety precautions are followed when performing battery maintenance on the Aerial Work Platform.

ALWAYS wear safety glasses when working with or near batteries.

ALWAYS check the battery fluid level daily.

ALWAYS avoid contact with battery acid. Battery acid causes serious burns and should be kept away from skin or eyes. If contact occurs, flush with water and consult a physician immediately.

ALWAYS disconnect ground cable first when removing battery.

ALWAYS connect ground cable last when installing battery.

ALWAYS charge batteries in open, well-ventilated areas.

ALWAYS replace batteries using only parts recommended by manufacturer. ALWAYS use only batteries with sealed caps over cells.

NEVER smoke while servicing batteries.

NEVER charge batteries near spark or open flame.

NEVER allow batteries to overcharge and boil.

NEVER short across battery posts to check for current. NEVER break a live circuit at the battery.

NEVER disconnect battery from charger while charger is connected to a live power source.

NEVER jumpstart other vehicles using the boom lift batteries.

DAMAGED EQUIPMENT POLICY

Safety Statement

At Bil-Jax, we are dedicated to the safety of all users of our products. All Bil-Jax lifts are designed, manufactured and tested to comply with current applicable federal OSHA and ANSI codes and regulations.

Damage Policy

There may be occasions when a Bil-Jax lift is involved in an incident that results in structural damage to the lift. Such damage can seriously compromise the ability of the lift to perform in a safe manner. Therefore, whenever a Bil-Jax lift is damaged structurally or when there is suspected internal damage to the structure, Bil-Jax may require that the lift be returned to our facility for reconditioning. For any questions concerning structural damage or the Damaged Equipment Policy, please contact the Bil-Jax Service Department at 800-537-0540.

Damage Repair Notice

There may be occasions when a Bil-Jax lift is involved in an accident resulting in damage to non-structural components. When such damage occurs and repairs are made by the owner or area distributor, please notify Bil-Jax of these non-maintenance repairs and request a repair form to be filled out and returned to Bil-Jax.

2 SPECIFICATIONS

Bil-Jax, Inc. is dedicated to the continuous improvement of this and all Bil-Jax products. Therefore, equipment information is subject to change without notice.

The following information is based on ideal working conditions. Machine performance may vary based on work environment and on machine options.

Direct any questions or concerns regarding equipment specifications to your regional Bil-Jax representative or to the Bil-Jax Service Department.

RANGE OF MOTION

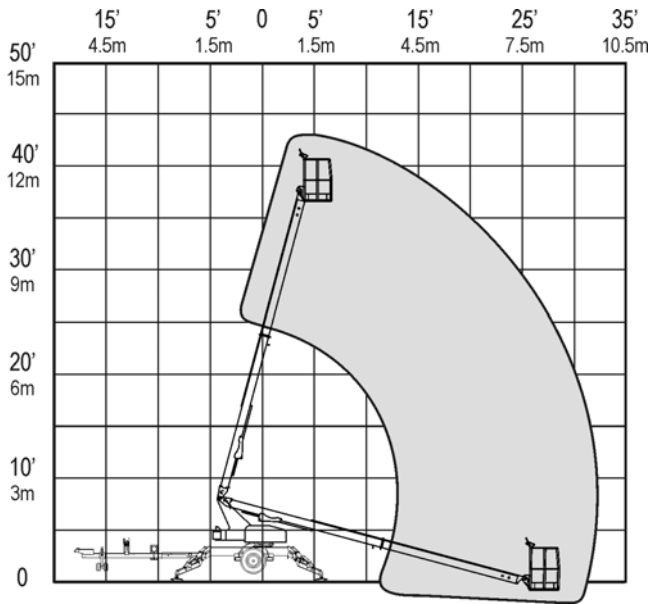

Figure 2-1. Range of Motion

SPECIFICATIONS

SERIAL NUMBER _____

Working Height	43 ft 6 in 13.4 m	Outrigger Footprint	
Maximum Platform Height	37 ft 6 in 11.4 m	Length	12 ft 2 in 3.7 m
Maximum Horizontal Outreach		Width	11 ft 4 in 3.4 m
From Centerline	32 ft 9.8 m	Footpad Diameter	12.5 in 0.3 m
From Outrigger Footpad Edge	27 ft 8.2 m	Brake	Spring Applied
Rated Platform Capacity		Speed	
Without Platform Rotation	500 lbs 227 kg	Gas Power	1.5 mph 5.6 km/h
With Platform Rotation	440 lbs 200 kg	DC Power	1.75 mph 2.8 km/h
Maximum Occupants	2	Tire Size	26 x 12 bar lug tires
Total Weight	4,680 lbs 2,123 kg	Tire Pressure	20 psi 140 kPa
Turtable Rotation	700° Non-Continuous	Control System	24V DC
Leveling Capability	12.5°	Battery	4 x 6V 245 amp-hr
Gradeability	45%	Battery Charger	110/120 Volt
Wheel Base	8 ft 8 in 2.7 m	Gas Engine	Kawasaki 21 HP
Turning Radius		Hydraulic Pressure	3,000 PSI 20,684 kPa
Inside	10 ft 3 m	Reservoir Capacity	4.8 Gallons 18.2 L
Outside	18 ft 5.5 m	Hydraulic System Capacity	7 Gallons 26.5 L
Platform Dimensions		Hydraulic Oil (Standard)	Dexron III/Mercon ATF
Height	3 ft 7 in 1.1 m	Platform Rotation/Type (Optional)	90°/Manual
Length	2 ft 6 in 0.8 m	Maximum Decibel Level	
Width – US/CE	5 ft/4 ft 1.5 m/1.2 m	DC Mode – Ground	60 dB
		DC Mode – Platform	55 dB
		Gas Mode – Ground	70 dB
		Gas Mode - Platform	65 dB
Stowed Dimensions		Localized Pressure per Outrigger	25 PSI 1.8 kg/cm ² 176.5 kPa
Height	6 ft 6 in 2.0 m	Operation Temperature Range	-20° to 110° Fahrenheit -29° to 43° Celsius
Length (Platform stowed)	20 ft 10 in 6.4 m	Max. Pressure Per Tire – Floor Loading	35 PSI 2.5 bar
Width	5 ft 5 in 1.7 m		

WARRANTY

Bil-Jax, Inc. warrants this product for one year, beginning on the date of delivery, to be free from defects of material and workmanship provided the unit is operated and maintained in compliance with the guidelines established in the Operations and Maintenance Manuals. Major structural components, including trailer tongue and boom weldments, are warranted for five years against defects due to material or workmanship. Bil-Jax will, at its option, repair or replace any unit or component part that fails to function properly during normal use.

The warranty does not apply if the lift and/or its components have been altered, changed, or repaired without the consent of Bil-Jax. Repairs, damage, or defects resulting from the following are not covered under the terms of the warranty: negligence, misuse, accidental damage, inadequate or improper maintenance, acts of nature, damage caused by chemicals or abrasive materials, and normal wear and tear, such as rust or corrosion. Components not covered under this warranty include tires, filters, covers, and routine maintenance items. Components not manufactured by Bil-Jax are covered by their respective manufacturer's warranties. A list of those components and their warranties is available upon written request to Bil-Jax.

Bil-Jax shall not in any event be liable for the cost of any special, indirect, or consequential damages to any person, product, or thing. Bil-Jax's maximum liability under this warranty is limited to the amount paid to Bil-Jax for the product. This warranty is in lieu of all other warranties expressed or implied. Bil-Jax neither assumes nor authorizes any or other entity to assume on its behalf any other liability in connection with the sale, rental, or use of this product.

Warranty Claims Process

In order to qualify for warranty coverage, the following conditions must be met:

- 1) Return of completed "Warranty Registration" form to Bil-Jax within 15 days of receipt of product;
- 2) Notification to Bil-Jax within 72 hours of any claimed defect, injury, or damage resulting from the claimed the defect; and
- 3) Warranty is limited to parts that are determined to be defective. This does not include parts worn out due to normal use.

Bil-Jax authorized dealers or distributors are responsible for filing claims under warranty. Listed below is the warranty claims procedure.

- 1) Contact Bil-Jax Service Department at 800-537-0540 to report the claim and verify warranty coverage. Machine serial number must be provided.
- 2) Identify the components to be claimed under warranty along with description of failure. A Returned Merchandise Authorization (RMA) number will be issued by Bil-Jax.
- 3) Replacement parts will then be sent by Bil-Jax to the dealer or distributor. All parts are invoiced at dealer/distributor list price. Credits will be issued when defective parts are returned to Bil-Jax and found to be defective under warranty.
- 4) After completing repairs, submit warranty claim form and defective parts to Bil-Jax. Warranty claim form and parts must be received within 30 days of claim in order to be eligible for credit. RMA number must be referenced on warranty claim form. Returned parts are to be sent prepaid and will be credited when part is received and verified. Warranty labor rate will be paid at current rate set by Bil-Jax. The amount of labor hours reimbursed will be determined by Bil-Jax and will be limited to 4 hours unless approved by Bil-Jax.

Failure to follow the warranty claims process may result in delay in processing claim or denial of the claim. Bil-Jax reserves the right to limit or adjust warranty claims with regard to parts, labor and travel time. Components purchased from suppliers other than Bil-Jax are not covered under the terms of this warranty.

3 EQUIPMENT MAINTENANCE

Performing the appropriate maintenance procedures will extend the life of the boom lift and will help ensure the safety of personnel operating the equipment.

Repair, replacement or adjustment of any hydraulic or electrical control device should be performed only by fully trained and authorized personnel. These include, but are not limited to, hydraulic load valves, hydraulic flow control valves, solenoid valves and limit switches. These are safety related controls. Improper adjustment or tampering with these devices may impair boom lift function and result in safety or damage hazards.

Persons performing maintenance or repairs on the machine, including weld repairs, should be trained in accordance with the manufacturer's recommendations. Contact your regional Bil-Jax representative if additional information is needed.

Critical or suspect areas identified during any scheduled inspection of the machine shall be examined by qualified personnel in accordance with applicable government regulations.

Never operate the machine if a defect or malfunction is identified or suspected. All defects and malfunctions must be repaired, and all maintenance performed, before returning a machine to service.

This manual contains a list of recommended maintenance procedures to be performed daily, weekly, monthly and annually.

When servicing the internal combustion engine installed on this machine, always follow the guidelines specified by the engine manufacturer.

It is the practice of Bil-Jax, Inc. to issue Service and/or Safety Bulletins, which may include updates to the information contained in this manual. In such instances, procedures contained in Bil-Jax Service Bulletins or Safety Bulletins supersede the information contained in manuals.

Always follow maintenance schedule, regardless of use.

DAILY SERVICE CHECKS

The following maintenance procedures should be performed daily or before each operation.

Verify that all decals are correctly applied and in plain view.

- ❑ Refer to Section 5 for decal locations.

Verify that all controls and indicators at ground and platform control stations operate properly.

- ❑ Lower outriggers to level the boom lift.
- ❑ Raise and extend all booms.
- ❑ Press emergency STOP button.
- ❑ Verify that booms remain elevated and do not drift.
- ❑ Pull out STOP button and lower the booms.
- ❑ If either control station is unresponsive, refer to Table 3-1 for troubleshooting procedures.
- ❑ If display panel displays an error code, refer to Table 3-2 for error code definitions.

Verify correct tire inflation.

- ❑ Inflate tires to 20 psi (140 kPa).

Inspect tires for damage or loose or missing lug nuts.

- ❑ Repair or replace as necessary.*

Inspect structural components and platform for obvious damage or debris.

- ❑ Repair or replace as necessary.

Inspect machine for missing, loose or damaged fasteners, including pins and bolts.

Check engine oil level.

- ❑ Add oil as needed.
- ❑ Manufacturer recommends engine oil type 5W-30.

Check engine fuel level.

- ❑ Add fuel as needed.

Verify that boom down limit switches operate correctly.

- ❑ Down limit switches are actuated when the boom is in a fully lowered, stowed position. Limit switches must be operational to raise or lower outriggers.
- ❑ If outrigger controls are unresponsive when boom is fully lowered and stowed, inspect down limit switches for loose mounting or visible damage.
- ❑ Repair or replace as needed.

Verify that outrigger safety interlocks operate correctly.

- ❑ Begin with the outriggers fully extended and the boom lift level. Raise one outrigger until the footpad is not in contact with the ground.
- ❑ Verify that boom functions are unresponsive when one outrigger is raised.
- ❑ Repeat this procedure for each outrigger.
- ❑ Raise all outriggers until the footpads are not in contact with the ground. Verify that all outrigger status LEDs on the ground control panel are unlit.
- ❑ Lower one outrigger until the footpad makes contact with the ground and the outrigger begins lifting the trailer.
- ❑ If the LED is lit before the footpad makes contact with the ground or if the LED remains unlit after the weight is transferred to the outrigger, the position switch or wiring is faulty.
- ❑ Repeat this procedure for each outrigger.
- ❑ Repair or replace as needed. Refer to Figure 2-1.

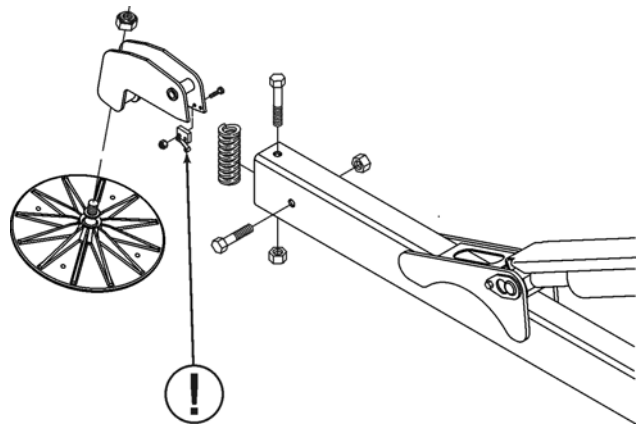

Figure 3-1. Outrigger Position Switches

*Repair and replacement of machine components should be performed only by trained and certified personnel in accordance with government regulations and manufacturer recommendations.

Inspect hydraulic system and fluid levels.

- ❑ Check all hydraulic hoses and fittings for leaks and damage. Tighten or replace as necessary to prevent hydraulic oil or pressure loss.
- ❑ The hydraulic oil level should be checked with the booms down, all outriggers raised and the trailer wheels on a level surface.
- ❑ Hydraulic oil level should be visible in, but not above, the sight gauge.
- ❑ If the hydraulic oil level is not visible to at least half way up the sight gauge (Figure 3-2), add clean hydraulic fluid as necessary while all booms and outriggers are fully retracted and stowed. Pour slowly to avoid creating air pockets in the reservoir. Do not fill above sight gauge. Overfilling the hydraulic reservoir may cause damage to hydraulic lines and may result in equipment malfunction.



CAUTION

Do not mix hydraulic oils. Do not add any fluid to the hydraulic system that is not expressly recommended by the manufacturer. Adding unauthorized fluids to the hydraulic system may cause damage to equipment

- ❑ The hydraulic reservoir is originally filled with Dexron III/Mercon ATF with a viscosity rating of 175.
- ❑ Manufacturer recommends a higher viscosity hydraulic oil when operating equipment routinely in extreme climates.

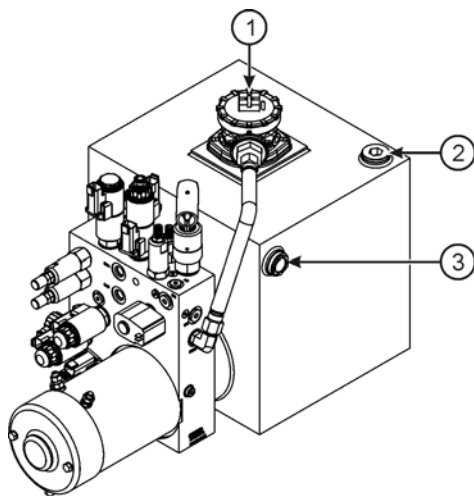

1. Filter Element
2. Fill Port
3. Sight Gauge

Figure 3-2. Hydraulic Reservoir

WEEKLY SERVICE CHECKS

Perform the following service checks at least once each week in addition to all recommended Daily Service Checks:

Check Battery electrolyte level.

- If electrolyte level is low, add enough water to bring the electrolyte level to the top of the plates.
- If batteries are fully charged, raise electrolyte level to full mark in each cell.

Inspect all electrical wiring.

- Check for cuts, loose terminals, broken wires, chaffing and corrosion.
- Repair all damage, remove corrosion and seal exposed connections.

Inspect boom lift for missing, loose or damaged hardware.

- Repair or replace as necessary.

Inspect all hydraulic system components including pump and motor and cylinders for damage, leaks, loss of pressure or speed, and unusual noise or vibration.

- Repair or replace as necessary.

MONTHLY SERVICE CHECKS

Perform the following service checks at least once each month:

Clean all battery terminals.

Check battery for loose connections or damaged wires.

Verify proper operation of manual lowering valves and hand pump

- ❑ Refer to Section 3 for manual boom operating procedures.

Lubricate all compartment hinges and latches, slew ring and mating gear.

- ❑ Use NLGI Grade 2 multi-purpose grease.

Check wheel nut torque.

- ❑ Refer to Figure 4-3 for correct wheel nut tightening sequence.
- ❑ Evenly tighten wheel nuts to 34 N*m in the tightening sequence shown.
- ❑ Repeat sequence, tightening wheel nuts to 81 N*m and to 136 N*m.

NOTE: Follow this procedure each time the wheel is removed and reinstalled.

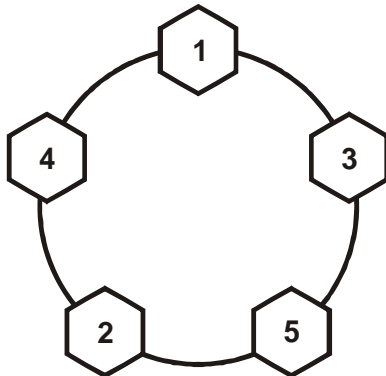

Figure 3-3. Wheel Nut Tightening Sequence

ANNUAL SERVICE CHECKS

Perform the following service checks at least once each year:

Replace Hydraulic Oil and Oil Filter.

- ❑ Drain hydraulic reservoir, clean and replace oil.
- ❑ Wipe away dirt and excess oil from around filter using cleaning cloths and alcohol solvent.
- ❑ Loosen and remove filter. Use absorbent cloths to keep excess oil from leaking onto the machine. Discard used filter.
- ❑ Wipe away dirt and excess oil from around filter housing.
- ❑ Install new filter. Do not over-tighten.
- ❑ With the fill port cap on but not tightened, completely raise and lower all booms to bleed trapped air from the lift cylinders. Repeat as necessary.
- ❑ Replace yearly, or whenever filter or oil contamination has a noticeable effect on boom functions.

Inspect pivot pins and cylinders, including rod ends, for wear or damage. Replace as necessary.

Visually inspect welds and structural components for wear, damage and corrosion.

- ❑ Follow all manufacturer's recommendations when making repairs to critical components.
- ❑ Personnel making repairs to welds should be certified in accordance with applicable government regulations.

Inspect outriggers for wear or damage. Repair or replace as necessary.

Verify that Level Sensor is operating correctly.

- ❑ Fully deploy outriggers until all Outrigger LEDs and AUTO LEVEL LED are lit, and buzzer sounds.
- ❑ Verify that machine is level, and that level sensor is giving an accurate reading.
- ❑ Repair or replace as necessary.

Inspect and adjust axles and brakes.

Load test boom lift operations with 500 lb (187 kg) load.

Check slew bearing for wear or damage.

- ❑ Check bolts for wear or damage.
- ❑ With the boom lift fully retracted, measure the distance between the slew ring gear and the horizontal plate above. Use a 2-inch (50 mm) caliper or bore micrometer. Record the measurement (Figure 3-4).
- ❑ Place a 175 lb (65 kg) load on the boom lift platform.
- ❑ Measure the distance between the slew ring and the horizontal plate above. Record the measurement.
- ❑ If the difference in measurements is greater than .25 in (6.35 mm) the slew ring bearing should be replaced. Contact manufacturer for replacement instructions and assistance.

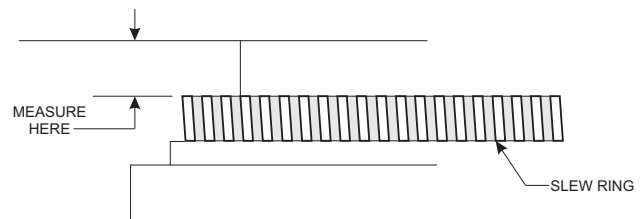

Figure 3-4. Slew Ring Position Measurement

STRUCTURAL INSPECTION

A comprehensive structural inspection of the unit shall be performed under any of the following conditions.

- ❑ Ten years from the date of manufacture and every five years thereafter.
- ❑ After any actual, suspected or potential damage is sustained that could affect the structural integrity or stability of the aerial platform.
- ❑ After a change in ownership. Owners should provide a complete service history when reselling the unit.

The structural inspection shall include the following considerations.

- ❑ The service history of the unit, including hours of service, work performed and environmental conditions.
- ❑ The inspection and maintenance record of the unit.
- ❑ The effectiveness of all controls and components.
- ❑ A visual inspection of the unit for wear or damage.
- ❑ Manufacturer recommendations.
- ❑ A visual weld inspection, to be performed by qualified personnel in accordance with applicable government regulations.

ADDITIONAL SERVICE INFORMATION

Seals on hydraulic cylinders should be replaced every five years or as indicated by machine performance.

All service checks should be performed on a machine that has been stored without use for a period exceeding thirty days.

Check for air in the hydraulic system if the machine has been stored without use for a period exceeding thirty days, or if the machine was stored without use during a seasonal climate change. Air trapped in the hydraulic system will affect machine performance. Follow procedures for bleeding air from the hydraulic system, found in Section 4.

Owners and lessors should complete a full inspection of all components and perform a test of all functions, including brake functions, before commissioning or reselling machine. Always repair or replace all damaged or malfunctioning components before commissioning or reselling machine.

When a change in ownership occurs, it is the responsibility of the seller to provide the new owner with all manuals for the machine. It is the responsibility of the buyer to notify the manufacturer of the unit model and serial number and the name and address of the new owner within 60 days.

Use the Service Checklists found at the back of the Operator's Manual to record all Service Checks as well as any maintenance, repairs or alterations performed on the machine.

Records of frequent safety checks need not be made. However, where a safety hazard is found, it shall be reported in writing to the owner of the machine, and a record of any corrective action shall be maintained for five years or as required by the authority having jurisdiction.

Testing Machine Stability

The Summit Series aerial work platform has been tested for stability using a load equal to 150% of the rated capacity of the machine and placed at the center of the platform with the boom fully extended. Stability tests should be conducted only by trained personnel and only when the machine is properly anchored to safeguard against tipping.

TROUBLESHOOTING

Refer to Table 3-2 for basic troubleshooting operations. Additional information can be found in the Bil-Jax Model 45XA Operator’s Manual. Contact the Bil-Jax Service Department with any questions or before attempting any advanced troubleshooting operations.

Table 3-1. Troubleshooting Steps

PROBLEM	CAUSE	SOLUTION
No lights on panel when key switch is turned to the on position.	<ul style="list-style-type: none"> a. Emergency STOP engaged. b. Battery charge is low. c. Battery ground or in-series cable is loose. d. Battery main disconnect unplugged. 	<ul style="list-style-type: none"> a. Disengage Emergency STOP buttons. b. Recharge as needed. c. Inspect and repair battery connections. d. Plug in main disconnect.
Hydraulic function does not work and display window shows an error message	<ul style="list-style-type: none"> a. Fault detected by safety interlock microprocessor. b. Boom Lift electric or electronic failure 	<ul style="list-style-type: none"> a. Refer to Table 4-2 for error code definition and correction. b. Refer to Table 4-2 for error code definition and correction.
Outrigger indicator LED lights do not function.	<ul style="list-style-type: none"> a. Key switch turned to the OFF or platform controls position. b. Emergency STOP engaged. c. Outriggers not deployed. 	<ul style="list-style-type: none"> a. Turn key switch to ground controls position. b. Disengage emergency STOP buttons. c. Deploy all outriggers.
One or more boom controls do not function OR One or more boom controls function improperly OR One or more boom controls function intermittently.	<ul style="list-style-type: none"> a. Key switch is turned to the OFF or incorrect control position. b. Battery charge is low. c. Emergency STOP engaged. d. Battery ground or in-series cable loose. e. All outriggers not properly deployed. f. Hydraulic pump inoperative. g. Loose wiring connector. h. Valve solenoid not operating properly. i. Fault detected by system interlock. j. Broken or loose wire. 	<ul style="list-style-type: none"> a. Turn key switch to ground or platform controls position. b. Recharge battery. c. Disengage Emergency STOP buttons. d. Inspect and repair battery connections. e. Deploy all outriggers and level boom lift. f. Inspect pump; replace or repair as needed. g. Check wiring terminals in control box and at valve manifold; replace or repair as needed. h. Clean valve solenoid and recheck function(s); replace or repair as needed. i. Check display for system status. Refer to Table 4-2 for error code definitions and correction. j. Inspect wiring in control box and at valve manifold and valve coil; repair or replace as needed.

ERROR CODE DEFINITIONS

The DISPLAY PANEL located on the ground control panel indicates the present operating status of the boom lift. If an error condition is detected by the control processor during start-up or operation, the appropriate error code will be displayed on this panel.

Refer to Table 3-2 for a comprehensive list of Error Code Definitions and solutions.

Table 3-2. Error Code Definitions

ERROR MESSAGE	DEFINITION OF ERROR	COMMENTS
001 MACHINE IS IN DOWN ONLY MODE	Machine was either never leveled, outriggers not lowered, or machine went out of level with use.	Retract boom to travel position and extend outriggers using AUTO LEVEL button.
002 LOSS OF PLATFORM COMMUNICATION	Ground control lost communication with platform control.	Check for unplugged or damaged platform control cable.
005 PLATFORM CONTROL HAS STUCK KEY	Platform control detected a stuck or pressed key on power up.	Turn key switch off and on again without pressing any buttons.
008 GROUND CONTROL HAS STUCK KEY	Ground control detected a stuck or pressed key on power up.	Turn key switch off and on again without pressing any buttons.
009 BOOM UP WITHOUT OUTRIGGERS ON GROUND	Ground control detected the boom is up and all outriggers are not on the ground	Retract boom to travel position and extend outriggers using AUTO LEVEL button.
010 LEVEL SENSOR HAS ERRATIC OUTPUT	The ground control detected an erratic output from the level sensor.	Retract and extend outriggers using AUTO LEVEL button.
015 MACHINE IS NOT LEVEL	Machine has gone out of level with use.	Retract and extend outriggers using AUTO LEVEL.
016 LIFT BOOM	A boom rotate, extend, or retract function requested with boom down.	Raise boom from travel position.
017 STOW BOOM	An outrigger function requested with boom up.	Retract and lower boom to travel position.
021 OPEN CIRCUIT PRIMARY UP	A load of less than 70mA detected in primary up circuit on power-up.	Check for faulty boom up solenoid coil and wiring.
022 SHORTED CIRCUIT PRIMARY UP	Excessive load detected in primary up circuit on power-up.	Check for faulty boom up solenoid coil and wiring.
023 OPEN CIRCUIT PRIMARY DOWN	A load of less than 70mA was detected when primary down circuit was energized	Check for faulty boom down solenoid coil and wiring.
024 SHORTED CIRCUIT PRIMARY DOWN	Excessive load detected when primary down circuit was energized.	Check for faulty boom down solenoid coil and wiring.
025 OPEN CIRCUIT SECONDARY UP	A load of less than 70mA detected in secondary up circuit on power-up.	Check for faulty boom up solenoid coil and wiring.
026 SHORTED CIRCUIT SECONDARY UP	Excessive load detected in secondary up circuit on power-up.	Check for faulty boom up solenoid coil and wiring.
027 OPEN CIRCUIT SECONDARY DOWN	A load of less than 70mA detected when secondary down circuit was energized	Check for faulty boom down solenoid coil and wiring.
028 SHORTED CIRCUIT SECONDARY DOWN	Excessive load detected when secondary down circuit was energized.	Check for faulty boom down solenoid coil and wiring.
029 OPEN CIRCUIT JIB UP	A load of less than 70mA detected in jib up circuit on power-up.	Check for faulty jib up solenoid coil and wiring.
030 SHORTED CIRCUIT JIB UP	Excessive load detected in jib up circuit on power-up.	Check for faulty jib up solenoid coil and wiring.

ERROR MESSAGE	DEFINITION OF ERROR	COMMENTS
031 OPEN CIRCUIT JIB DOWN	A load of less than 70mA detected when jib down circuit was energized	Check for faulty jib down solenoid coil and wiring.
032 SHORTED CIRCUIT JIB DOWN	Excessive load detected when jib down circuit was energized.	Check for faulty jib down solenoid coil and wiring.
033 OPEN CIRCUIT EXTEND	A load of less than 70mA detected in extend circuit on power-up.	Check for faulty boom extend solenoid coil/wiring.
034 SHORTED CIRCUIT EXTEND	Excessive load detected in extend circuit on power-up.	Check for faulty boom extend solenoid coil/wiring.
035 OPEN CIRCUIT RETRACT	A load of less than 70mA detected in retract circuit on power-up.	Check for faulty boom retract solenoid coil/wiring.
036 SHORTED CIRCUIT RETRACT	Excessive load detected in retract circuit on power-up.	Check for faulty boom retract solenoid coil/wiring.
037 OPEN CIRCUIT PLATFORM LEVEL UP	A load of less than 70mA detected in platform level up circuit on power-up.	Check for faulty level up solenoid coil/wiring.
038 SHORTED CIRCUIT PLATFORM LEVEL UP	Excessive load detected in platform level up circuit on power-up.	Check for faulty level up solenoid coil/wiring.
039 OPEN CIRCUIT PLATFORM LEVEL DOWN	A load of less than 70mA detected in platform level down circuit on power-up.	Check for faulty level down solenoid coil/wiring.
040 SHORTED CIRCUIT PLATFORM LEVEL DOWN	Excessive load detected in platform level down circuit on power-up.	Check for faulty level down solenoid coil/wiring.
041 OPEN CIRCUIT PLATFORM CW	A load of less than 70mA detected in platform CW circuit on power-up.	Check for faulty boom rotate solenoid coil/wiring.
042 SHORTED CIRCUIT PLATFORM CW	Excessive load detected in platform CW circuit on power-up.	Check for faulty boom rotate solenoid coil/wiring.
043 OPEN CIRCUIT PLATFORM CCW	A load of less than 70mA detected in platform CCW circuit on power-up.	Check for faulty boom rotate solenoid coil/wiring.
044 SHORTED CIRCUIT PLATFORM CCW	Excessive load detected in platform CCW circuit on power-up.	Check for faulty boom rotate solenoid coil/wiring.
045 OPEN CIRCUIT TURNTABLE CW	A load of less than 70mA detected in rotate CW circuit on power-up.	Check for faulty rotate CW solenoid coil/wiring.
046 SHORTED CIRCUIT TURNTABLE CW	Excessive load detected in rotate CW circuit on power-up.	Check for faulty rotate CW solenoid coil/wiring.
047 OPEN CIRCUIT TURNTABLE CCW	A load of less than 70mA detected in rotate CCW circuit on power-up.	Check for faulty rotate CCW solenoid coil/wiring.
048 SHORTED CIRCUIT TURNTABLE CCW	Excessive load detected in rotate CCW circuit on power-up.	Check for faulty rotate CCW solenoid coil/wiring.
049 OPEN CIRCUIT OUTRIGGER RETRACT	A load of less than 70mA detected in outrigger retract circuit on power-up.	Check for faulty outrigger retract solenoid coil/wiring.
050 SHORTED CIRCUIT OUTRIGGER RETRACT	Excessive load was detected when Outrigger Retract circuit was energized.	Check for faulty outrigger retract solenoid coil/wiring.
051 OPEN CIRCUIT OUTRIGGER EXTEND	A load of less than 70mA detected in outrigger retract circuit on power-up.	Check for faulty outrigger extend solenoid coil/wiring.
052 SHORTED CIRCUIT OUTRIGGER EXTEND	Excessive load was detected in outrigger extend circuit on power-up.	Check for faulty outrigger extend solenoid coil/wiring.
053 OPEN CIRCUIT LF OUTRIGGER	A load of less than 70mA detected in left front outrigger circuit on power-up.	Check for faulty solenoid coil/wiring at outrigger.
054 SHORTED CIRCUIT LF OUTRIGGER	Excessive load was detected in left front outrigger circuit on power-up.	Check for faulty solenoid coil/wiring at outrigger.
055 OPEN CIRCUIT RF OUTRIGGER	A load of less than 70mA detected in right front outrigger circuit on power-up.	Check for faulty solenoid coil/wiring at outrigger.

ERROR MESSAGE	DEFINITION OF ERROR	COMMENTS
056 SHORTED CIRCUIT RF OUTRIGGER	Excessive load detected in right front outrigger circuit on power-up.	Check for faulty solenoid coil/wiring at outrigger.
057 OPEN CIRCUIT LR OUTRIGGER	A load of less than 70mA detected in left rear outrigger circuit on power-up.	Check for faulty solenoid coil/wiring at outrigger.
058 SHORTED CIRCUIT LR OUTRIGGER	Excessive load detected in left rear outrigger circuit on power-up.	Check for faulty solenoid coil/wiring at outrigger.
059 OPEN CIRCUIT RR OUTRIGGER	A load of less than 70mA detected in right rear outrigger circuit on power-up.	Check for faulty solenoid coil/wiring at outrigger.
060 SHORTED CIRCUIT RR OUTRIGGER	Excessive load detected in right rear outrigger circuit on power-up.	Check for faulty solenoid coil/wiring at outrigger.
069 OPEN CIRCUIT PROPORTIONAL	A load of less than 70mA detected in proportional valve circuit on power-up.	Check for faulty solenoid coil/wiring at proportional valve.
070 SHORTED CIRCUIT PROPORTIONAL	Excessive load detected in proportional valve circuit on power-up.	Check for faulty solenoid coil/wiring at proportional valve.

4 CYLINDER REPLACEMENT

If repair or replacement of a boom lift or outrigger hydraulic cylinder or its component parts becomes necessary, observe the following procedures in accordance with the safety precautions established in Section 1 of this manual.

Removing the hydraulic cylinder from the boom lift may require the use of specialized tools and lifting equipment. NEVER attempt to operate overhead hoists or cranes or related equipment without proper training, authorization and supervision. Perform all maintenance procedures only in an area that is well-lit and well-ventilated. Bil-Jax, Inc. is not responsible for personal injury or property damage resulting from the improper use of equipment or failure to follow all procedures and related safety precautions.

Direct all questions regarding cylinder removal and replacement to your regional Bil-Jax representative or to the Bil-Jax Service Department at 800-537-0540.

LIFT CYLINDER REPLACEMENT

Use the following procedure to remove and replace faulty or damaged hydraulic cylinders on the boom lift:

WARNING

Repair and removal of the hydraulic cylinders requires the use of lifting straps and an overhead crane or lifting gear to support the boom lift and hydraulic cylinders. Personnel should be thoroughly trained in the operation of these devices before attempting installation or removal. Hydraulic cylinders are heavy and may have hydraulic oil on their surface. Failure to use proper equipment or to securely support boom and boom cylinders can result in damage to lift components, serious injury or death.

- ❑ Lower the boom until it is resting in a stowed position. When removing the slave cylinder, extend the articulating boom section until all pivot pins are exposed (approximately two feet).
- ❑ Press and hold the emergency lowering valve on the back of the jib boom section to relieve all hydraulic pressure to the cylinder. Repeat this process for the upper and lower boom sections. Refer to the 4527A Operator's Manual for emergency lowering valve locations and operating procedures.
- ❑ Turn key switch to the OFF position and remove the key.
- ❑ Locate the piston rod end of the cylinder to be removed (Figure 4-1). Unbolt and remove the retainer plate from each side of the pivot pin.
- ❑ Verify that the cylinder is supported by lifting straps and an overhead hoist.
- ❑ Remove the pivot pin using a hammer and a brass or hardwood drift.
- ❑ Use an overhead crane or lifting gear to raise the boom section. Adequate clearance is necessary to reach the cylinder valve block and hydraulic hose ports.
- ❑ Unplug the appropriate emergency lowering valve solenoid.
- ❑ Tag and number all hydraulic hoses that attach to the cylinder valve block. Use a marker to label the valve block ports with the appropriate hose numbers.
- ❑ Place absorbent cloths below the cylinder ports and detach hydraulic hoses from the cylinder. Elevate

hoses to prevent leakage. Plug or cap exposed hose fittings and cylinder ports.

- ❑ At the base of the cylinder, unbolt and remove retainer plate from each side of the pivot pin.
- ❑ Remove the pivot pin using a hammer and a brass or hardwood drift.
- ❑ Lift and remove the cylinder using an overhead hoist and lifting straps.
- ❑ Replace or reinstall the cylinder by following the above instructions in the reverse order of removal.
- ❑ Actuate the hydraulic system and check for leakage. Tighten hydraulic fittings as needed.
- ❑ Bleed trapped air from the hydraulic system by raising and lowering the boom with the reservoir fill port cap on but not tightened. Allow several minutes for trapped air to escape. Repeat as needed.

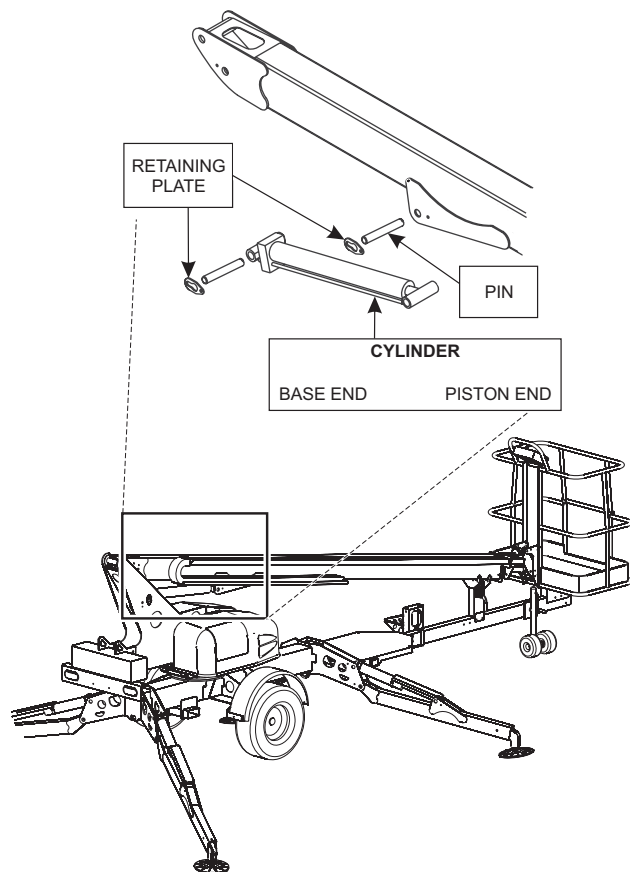

Figure 4-1. Lift Cylinder Replacement

OUTRIGGER CYLINDER REPLACEMENT

Use the following procedure to remove and replace faulty or damaged hydraulic cylinders on the outriggers:

- ❑ Lower the outrigger until the footpad is touching the ground. Do not transfer the weight of the boom lift onto the outrigger. Leave the weight of the boom on the trailer wheels.
- ❑ Remove the bolts securing the outrigger cylinder rod guard (Figure 4-2). Remove the guard.
- ❑ At the piston rod end of the cylinder, unbolt and remove the retainer plate from each side of the pivot pin.
- ❑ Place a block of wood shoring between the outrigger beam and cylinder.
- ❑ Remove the pivot pin using a hammer and a brass or hardwood drift.
- ❑ Fully retract the cylinder.
- ❑ Turn key to the off position and remove the key.
- ❑ Tag and number all hydraulic hoses that attach to the cylinder valve block. Use a marker to label the valve block ports with the appropriate hose numbers.
- ❑ Unplug the cylinder valve solenoid.
- ❑ Place absorbent cloths below the cylinder ports and detach hydraulic hoses from the cylinder. Elevate hoses to prevent leakage. Plug or cap exposed hose fittings and cylinder ports.
- ❑ At the base of the cylinder, unbolt and remove retainer plate from each side of the pivot pin.
- ❑ Remove the pivot pin using a hammer and a brass or hardwood drift.
- ❑ Lift and remove the cylinder using an overhead hoist and lifting straps.
- ❑ Replace or reinstall the cylinder by following the above instructions in the reverse order of removal.
- ❑ Actuate the hydraulic system and check for leakage. Tighten hydraulic fittings as needed.
- ❑ Bleed trapped air from the hydraulic system by raising and lowering the boom with the reservoir fill port cap on but not tightened. Allow several minutes for trapped air to escape. Repeat as needed.

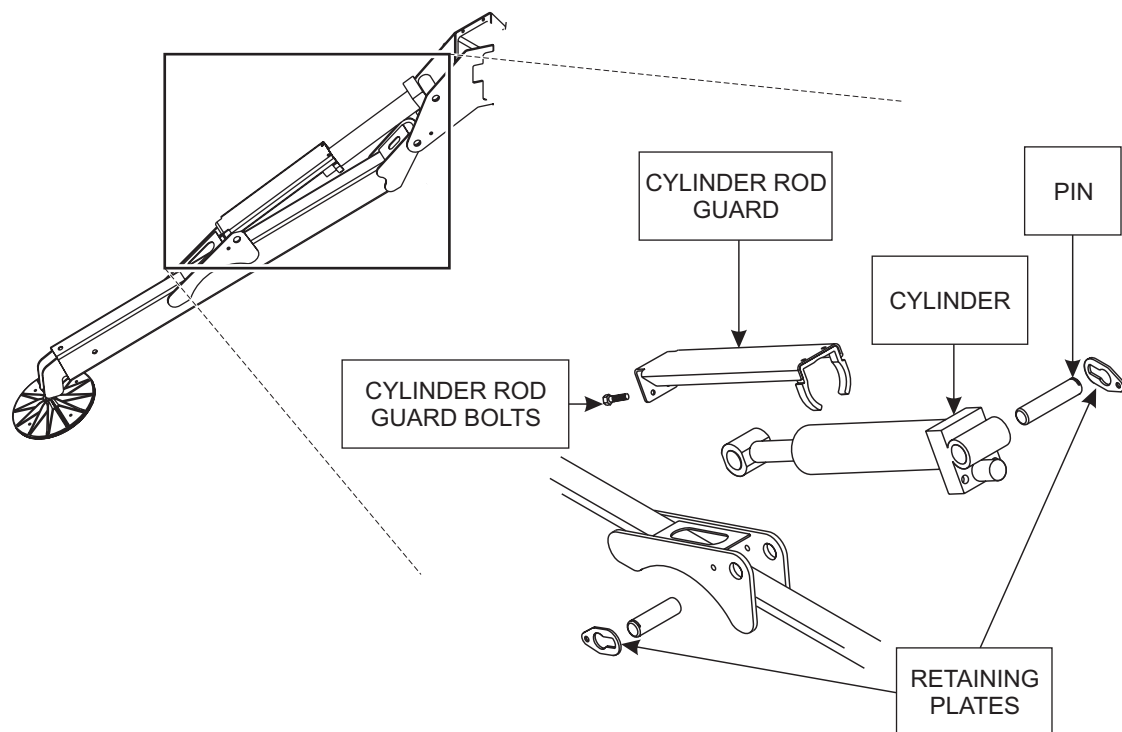

Figure 4-2. Outrigger Cylinder Replacement

5 REPLACEMENT DECALS

Decals contain information that is required for the safe and proper use of the aerial work platform. Decals should be considered necessary components of the machine and should be checked before each use to verify that they are correctly attached and legible.

Use the following guides to find the correct location of all decals.

Table 5-1. Decal Descriptions

Decal No.	Decal Description	Qty
0202-0523	Made in USA	1
B06-00-0034	DANGER: Electric Shock	1
B06-00-0037	Lubricate Semi-Annually	1
B06-00-0062	NOTICE: AC Power	2
B06-00-0068	NOTICE: Hydraulic System Oil	1
B06-00-0161B	Bil-Jax Logo, Black Transfer	2
B06-00-0404	WARNING: Outrigger Crush Toe	8
B06-00-0405	WARNING: Pinch Point	14
B06-00-0471	DANGER: Before Use/Main Instruction/Hazards (Platform)	1
B06-00-0473	NOTICE: Operator's Manual Missing	1
B06-00-0474	NOTICE: Max. Load	1
B06-00-0475	WARNING: Read/Understand Operator's Manual	1
B06-00-0476	NOTICE: Range of Motion	2
B06-00-0477	WARNING: Forklift Pockets	2
B06-00-0481	CAUTION: Transport Safety Latch	1
B06-00-0482	DANGER: Electrocution Hazard	2

Decal No.	Decal Description	Qty
B06-00-0484	DANGER: Battery/Charger Safety	1
B06-00-0494	NOTICE: Hazardous Materials	1
B06-00-0495	CAUTION: Compartment Access Restricted	2
B06-00-0503	NOTICE: Handle Applications	1
B06-00-0504	NOTICE: Emergency Hand Pump	1
B06-00-0505	DANGER: Before Use/Main Instruction/Hazards (ground)	1
B06-00-0506	NOTICE: Emergency Lowering	2
B06-00-0521	DANGER: Tip Over Hazard	5
B06-00-0541	CAUTION: Manual Boom Functions	1
B06-00-0545	Bil-Jax Website Transfer	2
B06-00-0552	NOTICE: Fall Protection Attachment points	1
B06-00-0561	WARNING: Operating Instructions (Ground)	2
B06-00-0562	WARNING: Operating Instructions (Platform)	1
B06-00-0563	36XT, 6" Black Transfer	2

Identification Plates

B06-00-0490	VIN Plate	1
B06-00-0499	ANSI ID Plate	1
B06-00-0524	Annual Inspection Plate	1
B06-00-0526	Key Tag	1

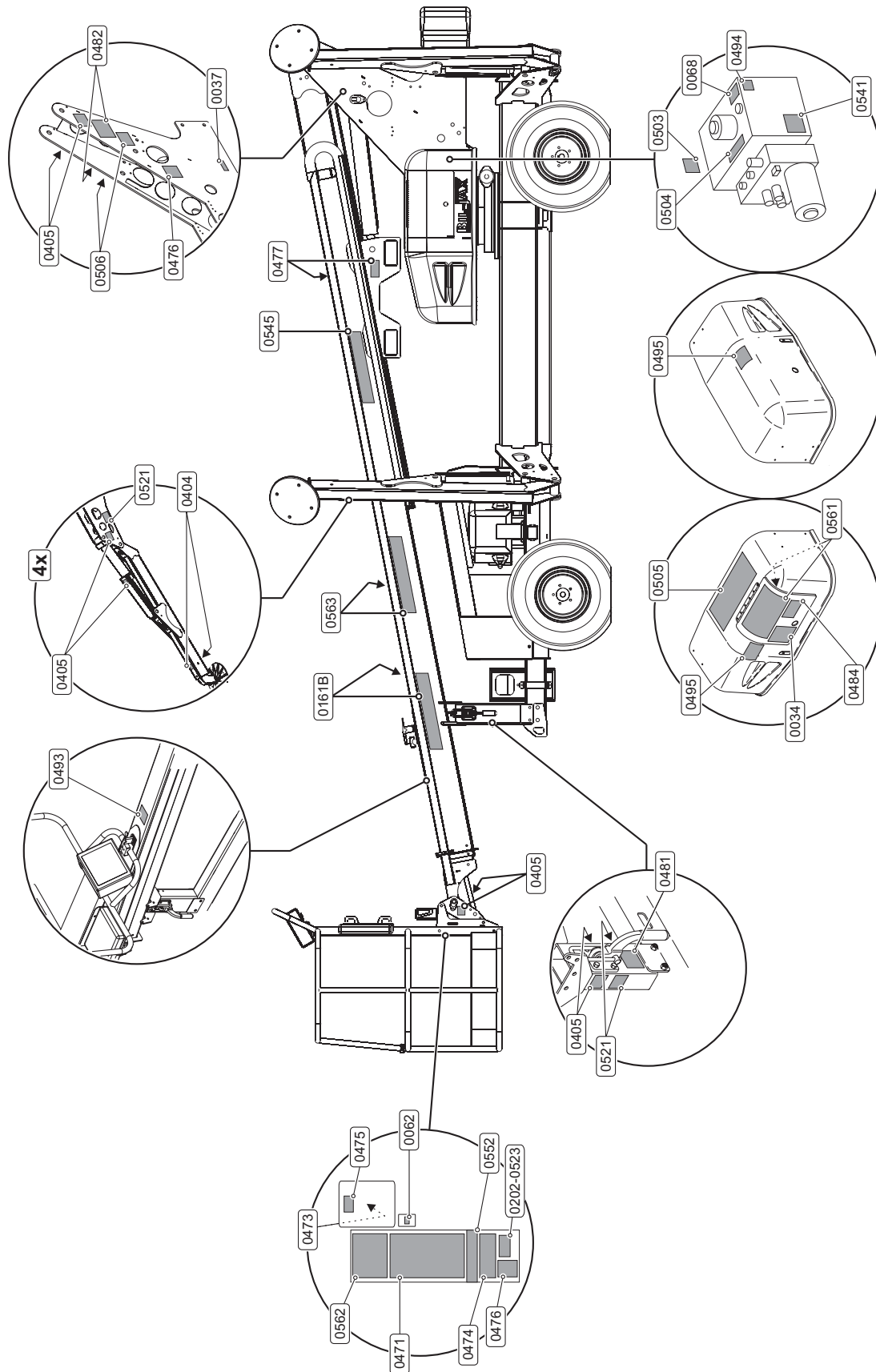

Figure 5-1. Decal Locations

Table 5-2. Decal Descriptions – CE

Decal No.	Decal Description	Qty	Decal No.	Decal Description	Qty
0202-0523	Made in USA	1	B06-00-0482	DANGER: Electrocutation Hazard	2
B06-00-0034	DANGER: Electric Shock	2	B06-00-0495	CAUTION: Compartment Access Restricted	2
B06-00-0037	Lubricate Semi-Annually	1	B06-00-0505	DANGER: Before Use/Main Instruction/Hazards (ground)	1
B06-00-0062	NOTICE: AC Power	2	B06-00-0506	NOTICE: Emergency Lowering	2
B06-00-0068	NOTICE: Hydraulic System Oil	1	B06-00-0541	CAUTION: Manual Boom Functions	1
B06-00-0161B	Bil-Jax Logo, Black Transfer	2	B06-00-0545	Bil-Jax Website Transfer	2
B06-00-0173	Fall Protection Attachment Points	1	B06-00-0561	WARNING: Operating Instructions (Ground)	2
B06-00-0404	WARNING: Outrigger Crush Toe	8	B06-00-0562	WARNING: Operating Instructions (Platform)	1
B06-00-0405	WARNING: Pinch Point	14	B06-00-0563	36XT, 6" Black Transfer	2
B06-00-0471	DANGER: Before Use/Main Instruction/Hazards (Platform)	1	B06-00-0568	WARNING: Outrigger Pressure	4
B06-00-0474	NOTICE: Max. Load	1	B06-00-0572	WARNING: Read/Understand Parts and Service Manual	1
B06-00-0475	WARNING: Read/Understand Operator's Manual	2			
B06-00-0476	NOTICE: Range of Motion	2			

Identification Plates

B06-00-0499-CE	CE Serial ID Plate	1
B06-00-0526	Key Tag	1

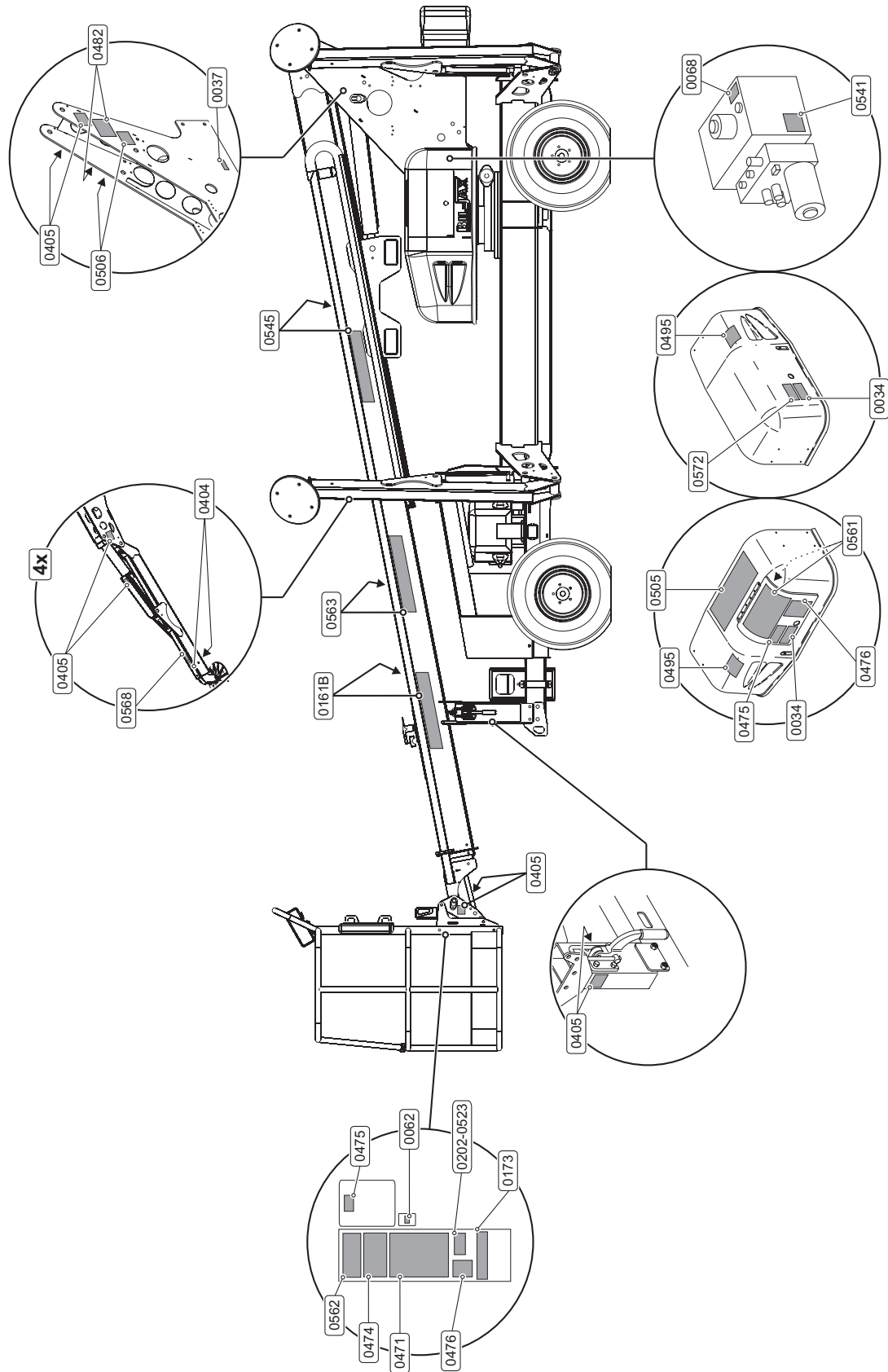

Figure 5-2. Decal Placement – CE

6 MATERIAL SAFETY DATA

The following Material Safety Data Sheets describe the correct procedures for the safe handling of chemical components within the Model 45XA Articulating Boom Lift, as well as any potential health and safety hazards related to these chemicals. Material Safety Data Sheets are included here in accordance with applicable federal and state regulations. Read and observe all safety precautions. Maintain awareness of potential health and safety hazards.

MATERIAL SAFETY DATA SHEET FOR LEAD ACID BATTERIES, WET, FILLED WITH ACID

SECTION I -- GENERAL INFORMATION					
Manufacturer's Name:	Crown Battery Mfg. Company	EMERGENCY NO: 800 487-2879			
Street Address:	1445 Majestic Drive	OR 800 OIL-TANK			
City, State, Zip	Fremont, Ohio 43420	REVISION DATE: 5/18/2000			
Phone Number:	419 334-7181				
SECTION II -- MATERIAL IDENTIFICATION AND INFORMATION					
COMPONENTS	PERCENT	OSHA PEL	ACGIH TLV	OTHER LIMITS	CAS NUMBER
Hazardous Components 1% or greater					
Carcinogens 0.01% or greater					
METALLIC LEAD METAL	25.5%	0.05 mg/m3	0.05 mg/m3	NONE	7439-92-1
LEAD SULFATES	18.2%	0.05 mg/m3	0.05 mg/m3	NONE	7439-92-1
LEAD OXIDES	18.0%	0.05 mg/m3	0.05 mg/m3	NONE	7439-92-1
POLYPROPYLENE CASE MTL	6.4%				
SEPARATORS	3.5%				
SULFURIC ACID (H2SO4)	5.2%	1.0 mg/m3	1.0 mg/m3	NONE	7664-93-9
WATER	19.2%				
REGULATORY INFORMATION:	Those ingredients listed above are not subject to the reporting requirements of 313 of Title III of the Superfund Amendments and Reauthorization Act. The items are covered in an exemption as a "Manufactured Article". 372.30(b)				
SECTION III -- PHYSICAL / CHEMICAL CHARACTERISTICS					
Boiling Point	Approximately 203F	Vapor Density:	Greater Than 1		
Vapor Pressure	14 @ 37% @ 80 F	Melting Point:	-36 F to -10.6 F		
Solubility in Water	100%	Water Reactive:	Yes, Produces Heat		
Specific Gravity	1.245 - 1.295 Battery Electrolyte				
Appearance & Odor	Clear Liquid with Sharp Pungent Odor				
SECTION IV -- FIRE AND EXPLOSION HAZARD DATA					
Flash Point:	Not Combustible				
Auto Ignition Temperature	N/A	Flammability Limits in Air % by Volume:	N/A		
Extinguishing Media:	Dry Chemical Carbon Dioxide, Water Fog, Water				
<u>Special Fire Fighting Procedures:</u>	Sulfuric Acid Fumes, Sulfur Dioxide Gas or Carbon Monoxide may be released when acid decomposes. Wear NIOSH approved self-contained breathing apparatus.				
<u>Unusual Hazards:</u>	Water applied to sulfuric acid generates heat and causes acid to splatter. Wear full-cover acid resistant clothing. Sulfuric acid reacts violently with metals, nitrates, chlorates, carbides, fulminates, picrates and other organic materials. Reacts with most metals to yield explosive/flammable hydrogen gas. This reaction is intensified when sulfuric acid is diluted with water to form battery electrolyte.				

MATERIAL SAFETY DATA SHEET

FOR LEAD ACID BATTERIES, WET, FILLED WITH ACID (Continued)

SECTION V -- HEALTH HAZARD DATA

Primary Routes of Entry:	Inhalation: YES Skin: YES Ingestion: YES
Health Hazards:	Acute EYES, SKIN, RESPIRATORY SYSTEM & DIGESTIVE SYSTEM Chronic: EYES, SKIN, RESPIRATORY SYSTEM & DIGESTIVE SYSTEM
Signs and Symptoms of Exposure:	IRRITATION OF EXPOSED AREA, BURNS AND RESPIRATORY PROBLEMS NO POSSIBILITY OF EXPOSURE OF LEAD WILL OCCUR UNLESS BATTERY IS DESTROYED.
Medical Conditions Generally Aggravated By Exposure:	EXPOSURE TO MIST MAY CAUSE LUNG DAMAGE & AGGRAVATE PULMONARY CONDITION.
Emergency First Aid Procedures:	SEEK MEDICAL ASSISTANCE FOR FURTHER TREATMENT, OBSERVATION AND SUPPORT IF NECESSARY.
Eye Contact:	WASH WITH COPIOUS QUANTITIES OF COOL WATER FOR AT LEAST 15 MINUTES
Skin Contact:	FLUSH AREA WITH LARGE AMOUNTS OF COOL WATER FOR AT LEAST 15 MINUTES
Inhalation:	REMOVE TO FRESH AIR, IF BREATHING IS DIFFICULT - GIVE OXYGEN
Ingestion:	GIVE MILK TO DRINK, <u>DO NOT</u> INDUCE VOMITTING. CALL PHYSICIAN

SECTION VI -- REACTIVITY DATA

Stability:	STABLE	Conditions to Avoid: N/A
Incompatibility:	AVOID COMBUSTIBLES, ORGANIC MATERIALS, AND STRONG REDUCING AGENTS	
Hazardous Decomposition Products:	SULFUR TRIOXIDE, CARBON MONOXIDE, SULFURIC ACID FUMES, & SULFUR DIOXIDE	
Hazardous Polymerization:	MAY OCCUR	Conditions to Avoid: N/A

SECTION VII -- SPILL OR LEAK PROCEDURES

Steps to be taken in case material is released or spilled:
CONTAIN SPILL, USING NON-COMBUSTIBLE MATERIALS: VERMICULITE, DRY SAND & EARTH. NEUTRALIZE WITH LIME, SODA ASH, SODIUM BICARBONATE, ETC.

Waste disposal method: CONSULT STATE ENVIRONMENTAL AGENCY. INDIVIDUAL STATE REGULATIONS VARY

Precautions to be taken in Handling & Storage: SEPARATE FROM INCOMPATIBLE MATERIALS, KEEP AWAY FROM FIRE, SPARKS AND HEAT

Other Precautions and/or Special Hazards:
CONTACT WITH METALS MAY PRODUCE TOXIC SULFUR DIOXIDE FUMES & MAY ALSO RELEASE FLAMMABLE HYDROGEN GAS. THIS REACTION IS INTENSIFIED WHEN DILUTED.

NFPA Rating:	HEALTH: 3	FLAMMABILITY: 0	REACTIVITY: 2	SPECIAL: 0
HMIS Rating:	HEALTH: 3	FLAMMABILITY: 0	REACTIVITY: 2	PERSONAL PROTECTION: X

SECTION VIII -- CONTROL AND PROTECTIVE MEASURES

Respiratory Protection:	ABOVE P.E.L.: NIOSH APPROVED, FITTED, FULL FACE RESPIRATOR
Protective Gloves:	ACID RESISTANT
Eye Protection:	FULL FACE PROTECTION
Ventilation:	LOCAL EXHAUST: VENTILATED AREA PREFERRED MECHANICAL: IF BELOW P.E.L. SPECIAL: MUST BE ACID & EXPLOSIVE RESISTANT OTHER: MUST BE ACID & EXPLOSIVE RESISTANT
Other Protective Equipment:	ACID RESISTANT CLOTHING AND BOOTS
Hygienic Work Practices:	N/A

MATERIAL SAFETY DATA SHEET
DEXRON III/MERCON AUTOMATIC TRANSMISSION FLUID (HYDRAULIC OIL)

SECTION I -- GENERAL INFORMATION	
TRADE NAME:	CITGO TRANSGARD™ ATF, DEXRON III/MERCON
EMERGENCY TELEPHONE NUMBERS:	918.495.4700 (medical); 800.424.9300 (chemical)
CHEMICAL FAMILY:	AUTOMATIC TRANSMISSION FLUID, LUBRICATING OIL
CAS NUMBER: MIXTURE:	REVISION DATE: 10/29/98
HAZARDOUS INGREDIENTS:	CONTAINS NO INGREDIENTS NOW KNOWN TO BE HAZARDOUS AS DEFINED IN OSHA 29 CFR 1910.1000 AND OSHA 29 CFR 1910.1200.
SECTION II -- HEALTH HAZARD DATA	
PRIMARY ROUTES OF ENTRY:	INHALATION, SKIN ABRASION AND INGESTION.
CARCINOGENIC:	NO
SYMPTOMS (INGESTION, CONTACT, INHALATION):	MILD, TRANSIENT SKIN OR EYE IRRITATION MAY OCCUR.
EYES:	FLUSH WITH WATER FOR 15 MINUTES
SKIN:	WASH THOROUGHLY WITH WARM SOAPY WATER.
INGESTION:	DO NOT INDUCE VOMITTING-SEEK MEDICAL ATTENTION.
CONDITIONS AGGRAVATED BY EXPOSURE:	NONE KNOWN
AIR EXPOSURE LIMITS: P.E.L. 5 mg/m3 (OSHA) T.L.V. 10mg/m3 (ACGIH)	
HEALTH: 0 FIRE: 1 SPECIFIC: X REACTIVITY: 0	
SECTION III -- PHYSICAL DATA	
BOILING POINT/FREEZING POINT:	N/A
VAPOR PRESSURE (PSIA):	N/A
SPECIFIC GRAVITY (H20=1):	0.86
SOLUBILITY IN WATER:	NEGLIGIBLE; INSOLUBLE IN COLD WATER
PH OF CONCENTRATE:	N/A
APPEARANCE AND ODOR:	RED LIQUID, MILD PETROLEUM ODOR
SECTION IV -- FIRE AND EXPLOSION HAZARD DATA	
FLASH POINT (METHOD USED):	CLOSED: 339° F (Pensky-Martens); OPEN: 390° F (Cleveland).
FLAMMABLE LIMITS:	NOT DETERMINED
LEL: N/A UEL:	N/A
EXTINGUISHING MEDIA:	DRY CHEMICAL, FOAM, CO2, WATER FOG. TREAT AS CLASS B FIRE.
UNUSUAL FIRE AND EXPLOSION HAZARDS:	PRODUCES COMBUSTIBLE VAPOR AT TEMPERATURES ABOVE FLASH POINT
SECTION V -- REACTIVITY DATA	
STABILITY:	STABLE
CONDITIONS TO AVOID:	AVOID EXTREMES OF HEAT; IGNITION SOURCES.
INCOMPATIBILITY (MATERIALS TO AVOID):	STRONG OXIDIZING MATERIALS.
HAZARDOUS DECOMPOSITION PRODUCTS:	INCOMPLETE COMBUSTION MAY CAUSE CARBON OXIDES.
HAZARDOUS POLYMERIZATION:	WILL NOT OCCUR.
SECTION VI -- SPECIAL PROTECTION INFORMATION	
RESPIRATORY PROTECTION (SPECIFIC TYPE):	NONE REQUIRED
VENTILATION:	NORMAL
LOCAL EXHAUST:	NORMAL
MECHANICAL EXHAUST (GENERAL):	X
PROTECTIVE GLOVES:	OIL IMPERVIOUS GLOVES RECOMMENDED
EYE PROTECTION:	SAFETY GLASSES RECOMMENDED
OTHER PROTECTIVE EQUIPMENT:	PROTECTIVE CLOTHING RECOMMENDED
SPECIAL LABELLING INSTRUCTIONS:	NOT REQUIRED
SPECIAL PACKAGING RECOMMENDATIONS:	NONE
HANDLING AND STORAGE RECOMMENDATIONS:	AVOID EXTREMES OF COLD OR HEAT. STORE IN CLEAN DRY AREA.
SPILL OR LEAK PROCEDURES:	IN CASE OF LEAK OR SPILL, DIKE AND ABSORB WITH INERT MATERIAL. FOLLOW ALL LOCAL, STATE AND FEDERAL REGULATIONS FOR DISPOSAL.
<p>DISCLAIMER: THE INFORMATION CONTAINED HEREIN HAS BEEN COMPILED FROM SOURCES CONSIDERED TO BE DEPENDABLE AND IS ACCURATE TO THE BEST OF THE SELLER'S KNOWLEDGE. THE SELLER MAKES NO WARRANTY WHATSOEVER, EXPRESSED OR IMPLIED, REGARDING THE ACCURACY OF SUCH DATA OR THE RESULTS TO BE OBTAINED FROM THE USE THEREOF.</p>	

APPENDIX: REPLACEMENT PARTS

Use only parts manufactured and/or authorized by Bil-Jax, Inc. when replacing damaged components. See page 89 for replacement part ordering information.

Only personnel properly trained and authorized to operate all equipment and familiar with all boom functions should attempt to repair or replace any part of the boom lift.

Always read, understand and obey all safety precautions included in this manual, as well as those precautions attached to the lift and dictated by federal, state and local regulations.

<u>Assembly Description</u>	<u>Page</u>
Outrigger	42
Engine	44
Front Rest	48
Front Axle	50
Rear Axle	52
Slew Ring	54
Counterweight	56
Control Compartment	58
Pump Compartment	60
Battery Compartment	62
Cover	64
Boom	66
Cable Track	70
Boom Nose	72
Platform	74
Hydraulic Pump	76

<u>Assembly Description</u>	<u>Page</u>
Boom and Rotation Hydraulic Lines	80
Outrigger Hydraulic Lines	82
Trailer Hydraulic Lines – 4WD	83
Wire Harnesses	86
Manifold Wire Harness	87
Gas Engine Wire Harness	87
Choke/Throttle Solenoid Wire Harness	88
Engine Relays Wire Harness	88
ATC Fuse Holder	89
Start/Stop/Run Wire Harness	89
Generator Switcher Box	90
Wire Assembly – Fan	90
IEC Cord – Male – US Markets	91
Generator 110V Wire Harness	91
Oil Switch	91
Cord Assembly – 110V Generator	92
Cord Assembly – Generator Switch	92
Cord Assembly – Switch Jumper	92
Cord Assembly – 110V AC Plug – Female	92
Switcher Box – CE Models	93
220V Generator Wire Harness – CE Models	93
Cord Assembly – 220V AC Plug – Female – CE Models	93
Pump And Cylinder Wire Harnesses	94
Outrigger Coil and Switches Wire Harness	95
Analog Harness	96
Power Harness	96
110 VAC Tower-Platform Harness	96
Platform-Ground Communication Cable	97
Material Hook	98
Battery Layout	100

OUTRIGGER ASSEMBLY

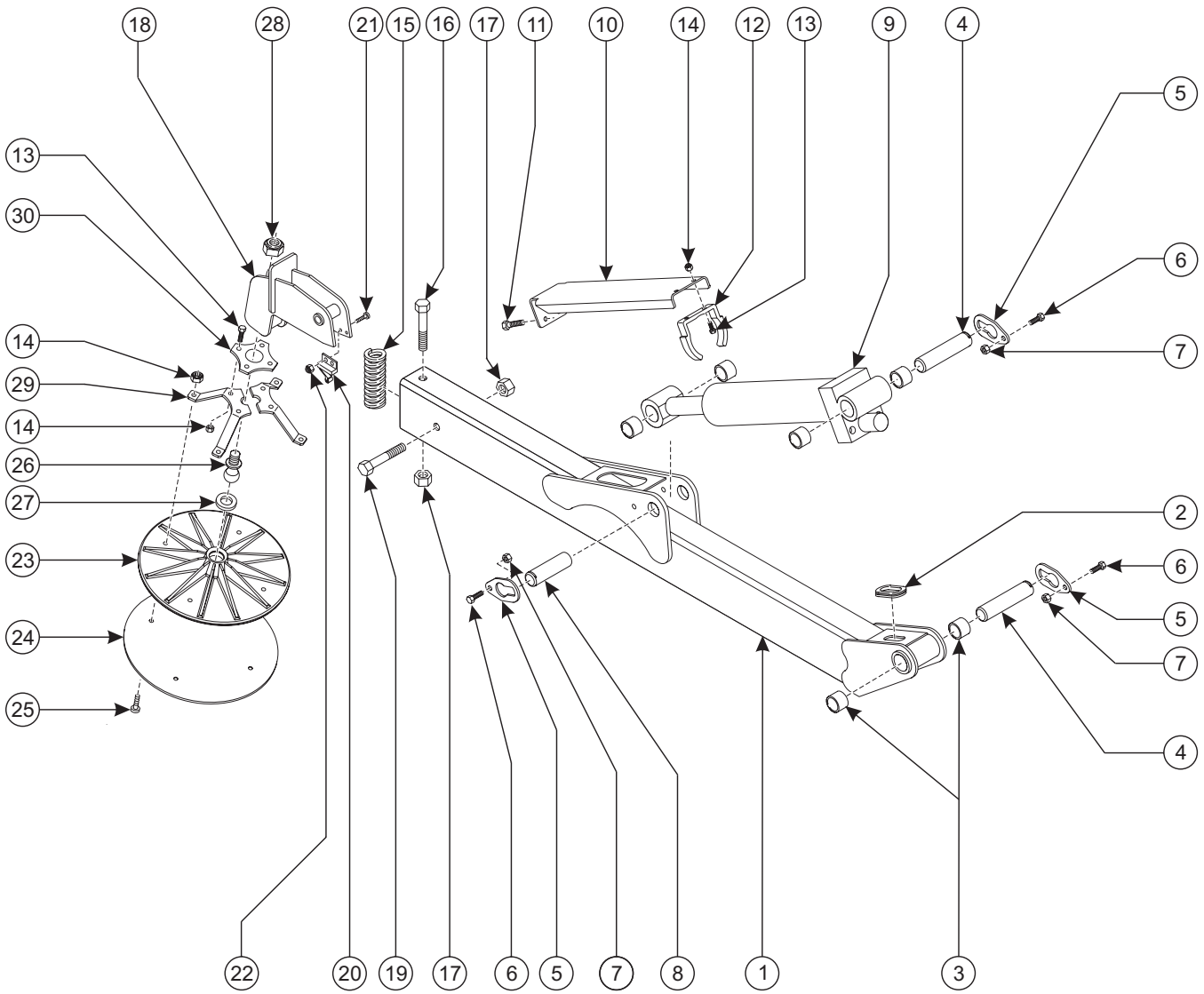

OUTRIGGER ASSEMBLY PARTS LIST

Item No.	Part No.	Description	Qty.
1	A-00120	Outrigger Weldment	1*
2	A-00046	Grommet – 1.5 x 1.25 x 1.75	1
3	A-00032	Bearing	2
4	A-00020	Pin, 1.25 x 5.5	2
5	A-00019	Pin Retainer, 1.25	3
6	0096-0016	Cap Screw, M10 x 25	3
7	0096-0041	Hex Nut, Self-Locking, M10	3
8	A-00060	Pin, 1.25 x 4.25	1
9	A-00138	Outrigger Hydraulic Cylinder	1
10	A-00141	Outrigger Cylinder Guard	1
11	0096-0009	Cap Screw, M8 x 10	2
12	A-00142	Guard Slide	1
13	0096-0010	Cap Screw, M8 x 20	6
14	0096-0040	Hex Nut, Self-Locking, M8	10
15	A-00154	Spring, Outrigger Sensor	1
16	0096-0036	Cap Screw, M16 x 150	1
17	0096-0044	Hex Nut, Self-Locking, M16	2
18	A-00128	Pad Mount Weldment	1
19	0096-0051	Cap Screw, M16 x 100	1
20	B01-03-0078	Limit Switch Assembly	1
21	0090-0232	Slotted Machine Screw, #10-24 x 5/8	2
22	0090-0182	Hex Nut, Self-Locking, #10-24	2
23	A-00136	Foot Pad, Aluminum, 12"	1
24	A-00137	Foot Pad Bottom, 12"	1
25	0096-0121	Flat Head Cap Screw, M8 x 30	4
26	A-00135	Foot Pad Ball	1
27	A-00195	O-Ring, 1 1/4" OD x 1" ID	1
28	0096-0045	Hex Nut, Self-Locking, M20	1
29	A-00127	Foot Pad Lock	2
30	A-00139	Foot Pad Lock Cap	1

*Quantities listed reflect the number of parts needed for **each** outrigger.

NOTE: Unless otherwise noted, high-strength Grade 5/Class 8.8 fasteners are used in the assembly of this equipment.

ENGINE ASSEMBLY (I)

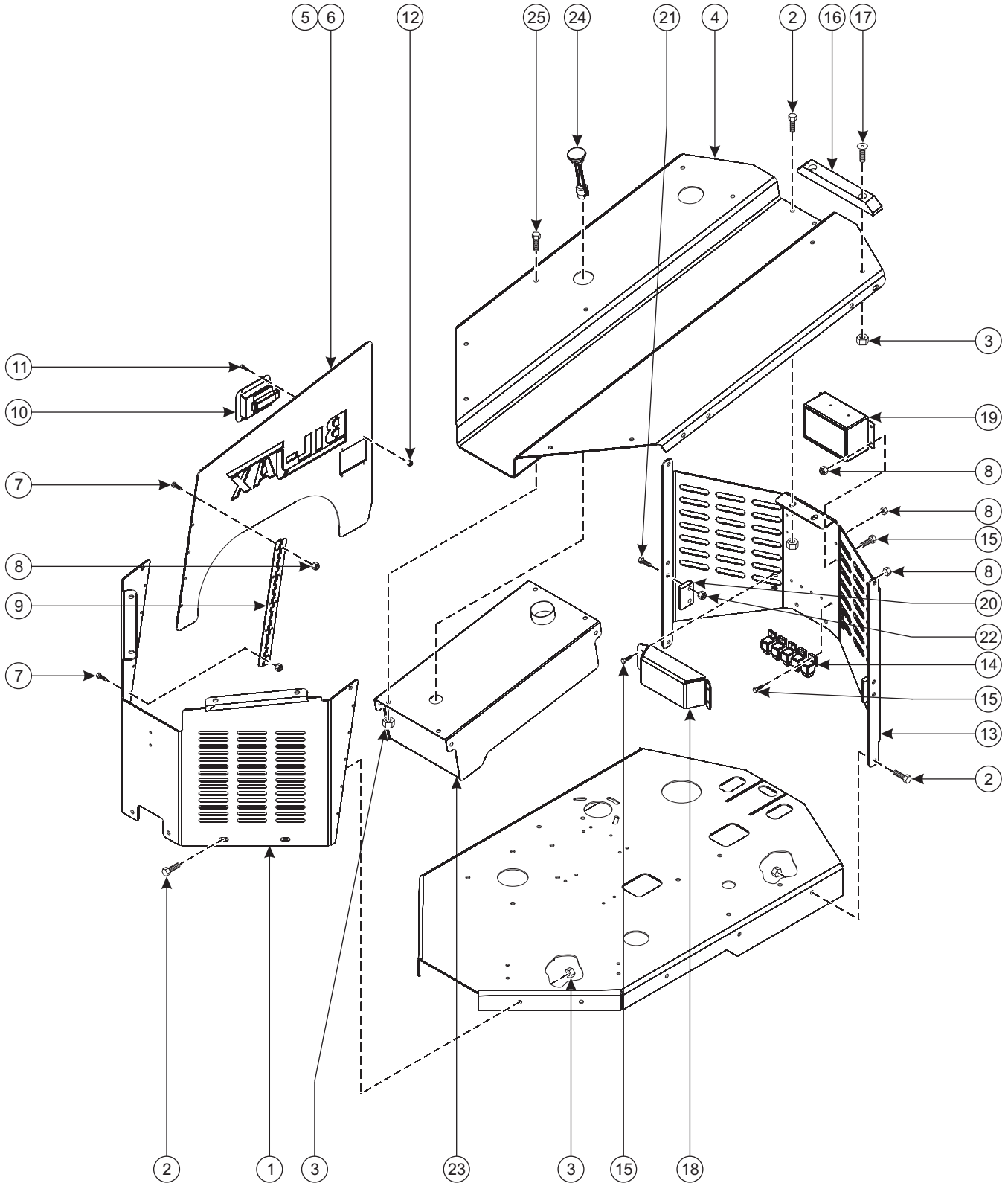

ENGINE ASSEMBLY (I) PARTS LIST

Item No.	Part No.	Description	Qty.
1	A-01063	Cover Front	1
2	0096-0014	Cap Screw, M10 x 20	14
3	0096-0041	Hex Nut, Self-Locking, M10	22
4	A-01064	Cover Top	1
5	A-01067	Cover Side – Left	1
6	A-01069	Cover Side – Right	1
7	0096-0001	Cap Screw, M6 x 16	20
8	0096-0039	Hex Nut, Self-Locking, M6	33
9	B42-01-1006	Hinge – 72” Continuous	2
10	A-01045	Latch, Paddle-Style	2
11	0096-0113	Cap Screw, M4 x 16	8
12	0096-0073	Hex Nut, Self-Locking, M4	8
13	A-01052	Cover Rear	1
14	B01-06-0053	Relay 24V DC w/ Bracket	5
15	0096-0002	Cap Screw, M6 x 20	13
16	A-A-01059	Cover Pad	2
17	0096-0068	Flat Head Cap Screw, M10 x 45	4
18	A-03048	Relay Cover	1
19	A-03040	Switcher Box Assembly	1
	B01-06-0056	Relay – 30 Amp	1
	B01-10-0354	Circuit Breaker – 20 Amp	1
	A-01015	Switcher Box	1
20	A-01072	Cover Latch Stop	2
21	0096-0098	Cap Screw, M8 x 35	4
22	0096-0040	Hex Nut, Self-Locking, M8	4
23	A-01047	Fuel Tank	1
24	A-01089	Fuel Gauge	1
25	0096-0016	Cap Screw, M10 x 25	2

ENGINE ASSEMBLY (II)

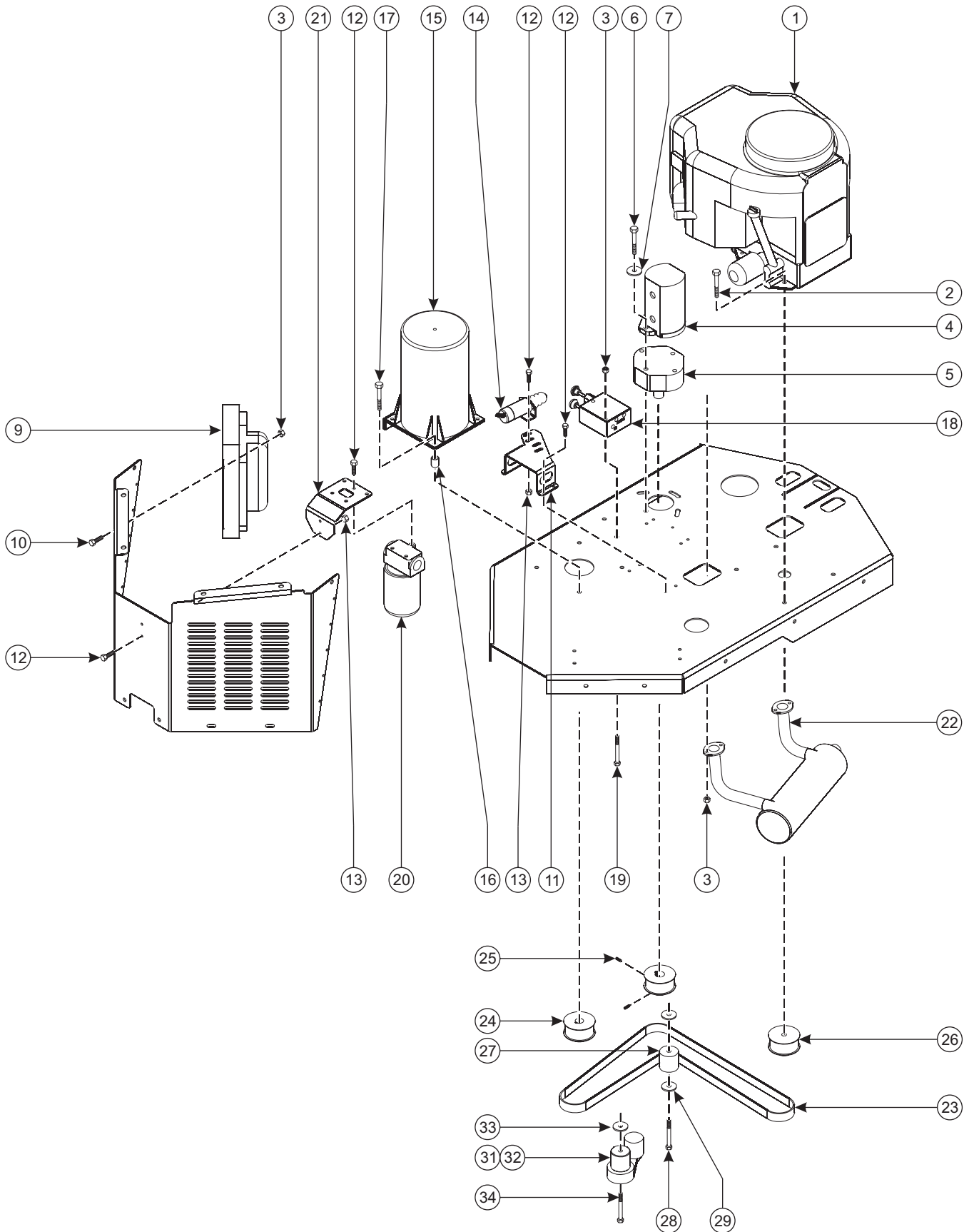

ENGINE ASSEMBLY (II) PARTS LIST

Item No.	Part No.	Description	Qty.
1	A-01046	Engine 21HP (See Manufacturer's Literature)	1
2	0096-0098	Cap Screw, M8 x 35	4
3	0096-0040	Hex Nut, Self-Locking, M8	18
4	A-01048	Pump – Dual – 4.5 GPM	1
5	A-01055	Dual Pump Mount	1
6	0096-0110	Cap Screw, M10 x 110	2
7	0096-0093	Washer, M10	2
8	0096-0041	Hex Nut, Self-Locking, M10	2
9	A-01081	Oil Cooler	1
10	0096-0010	Cap Screw, M8 x 20	4
11	A-01071	Solenoid Bracket	1
12	0096-0001	Cap Screw, M6 x 16	12
13	0096-0039	Hex Nut, Self-Locking, M6	10
14	A-01074	Throttle Solenoid Assembly	2
15	A-00761	Generator	1
16	A-01060	Spacer	4
17	0096-0053	Cap Screw, M8 x 50	4
18	A-01038	Brake Release – Hand Pump	1
19	0096-0108	Cap Screw, M8 x 70	2
20	B02-00-0071	Oil Filter Assembly	1
21	B29-00-0016	Oil Filter Bracket	1
22	A-00783	Exhaust Assembly	1
23	A-01061	Belt	1
24	A-01051	Pulley	2
25	0090-0363	Set Screw – 1/4 - 20 x 3/4	6
26	A-01036	Pulley	1
27	A-01088	Idler Roller	1
28	0096-0022	Cap Screw, M12 x 75	1
29	0096-0076	Washer, M12	3
30	0096-0041	Hex Nut, Self-Locking, M12	1
31	A-01095	Tension Arm	1
32	A-01086	Spacer – Tension Arm	1
33	0090-0210	Washer – 3/8"	1
34	0096-0069	Cap Screw, M10 x 75	1

FRONT REST ASSEMBLY

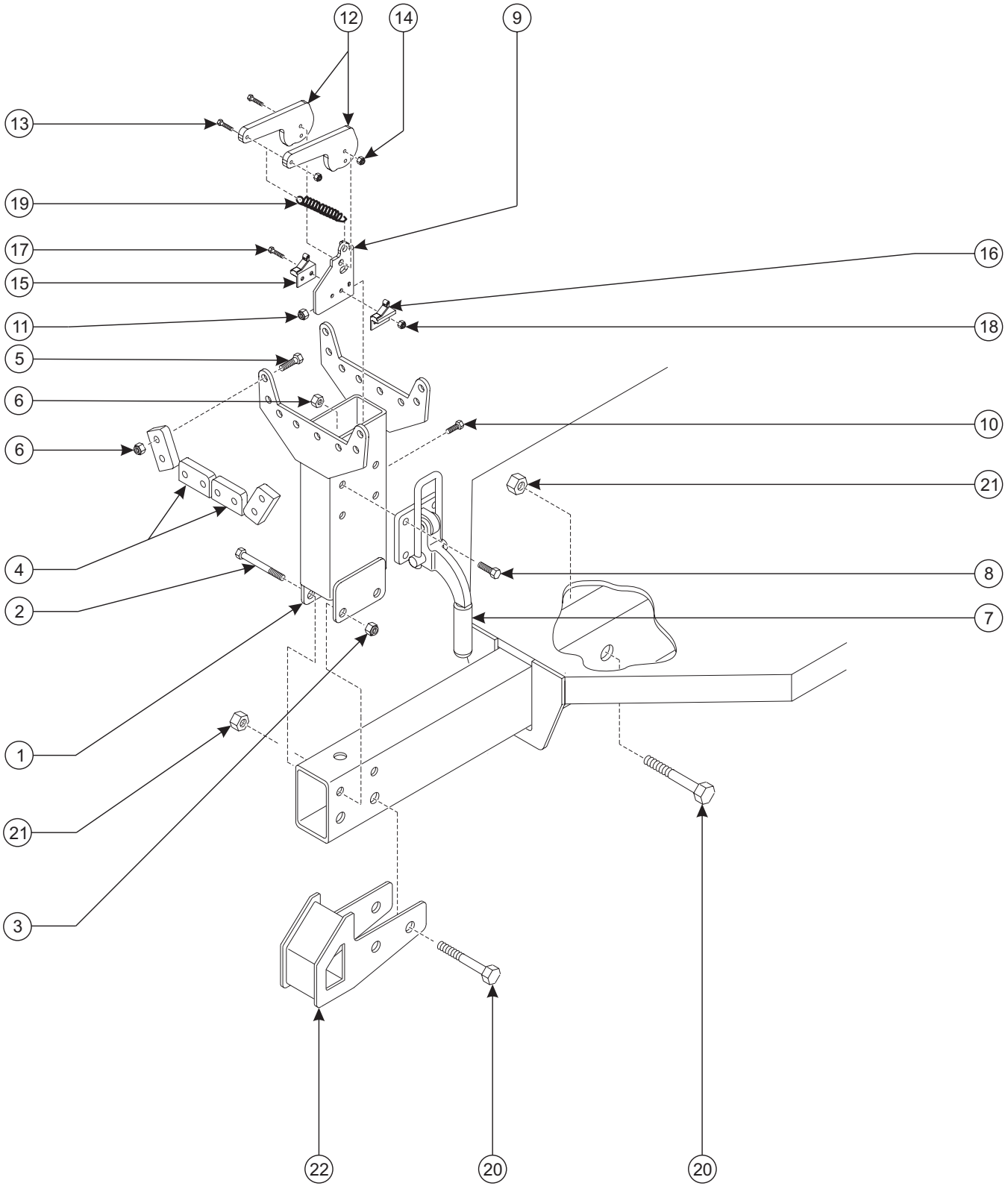

FRONT REST ASSEMBLY PARTS LIST

Item No.	Part No.	Description	Qty.
1	A-03145	Front Rest Weldment	1
2	0096-0024	Cap Screw, M12 x 100	2
3	0096-0042	Hex Nut, Self-Locking, M12	2
4	A-00157	Front Rest Pad	6
5	0096-0017	Cap Screw, M10 x 30	16
6	0096-0041	Hex Nut, Self-Locking, M10	20
7	A-00159	Boom Latch	1
8	0096-0016	Cap Screw, M10 x 25	4
9	A-00169	Switch Bracket	1
10	0096-0002	Cap Screw, M6 x 20	2
11	0096-0039	Hex Nut, Self-Locking, M6	2
12	A-00188	Switch Cam	2
13	0090-1104	Machine Screw, #4-40 x 1	3
14	0090-0525	Hex Nut, Self-Locking, #4-40	3
15	B01-03-0078	Limit Switch Assembly, NO (Female)	1
16	B01-03-0079	Limit Switch Assembly, NC (Male)	1
17	0090-0709	Machine Screw, #6-32 x 1 1/4	2
18	0090-0180	Hex Nut, Self-Locking, #6-32	2
19	A-00158	Tension Spring	1
20	0096-0038	Cap Screw, M20 x 120	4
21	0096-0045	Hex Nut, Self-Locking, M20	4
22	A-01082	Tie Weldment – 4WD	1

FRONT AXLE ASSEMBLY

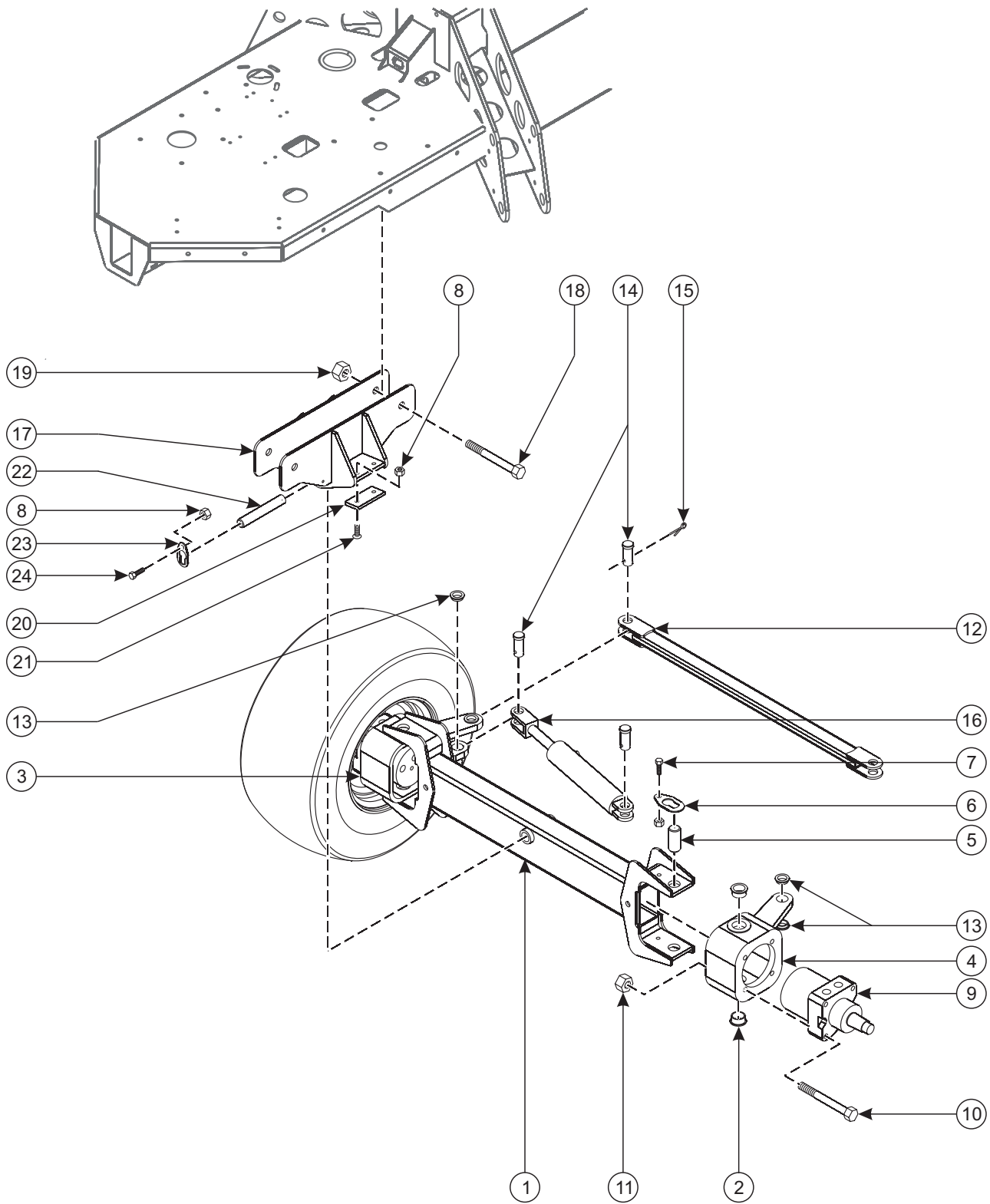

FRONT AXLE ASSEMBLY PARTS LIST

Item No.	Part No.	Description	Qty.
1	A-01010	Front Axle Weldment – 4WD	1
2	A-01097	Bushing, 1.5" OD x 1.25" ID	4
3	A-01020	Front Yoke – Left	1
4	A-01021	Front Yoke – Right	1
5	A-01070	Pin – 1.25" x 1.625"	4
6	A-00019	Pin Retainer – 1.25"	4
7	0096-0016	Cap Screw, M10 x 25	4
8	0096-0041	Hex Nut, Self-Locking, M10	9
9	A-01022	Hydraulic Motor – 4WD	2
10	0096-0024	Cap Screw, M12 x 100	8
11	0096-0042	Hex Nut, Self-Locking, M12	8
12	A-01025	Tie Rod – 4WD	1
13	A-01096	Bushing, 1.25" OD x 1.0" ID	4
14	A-01085	Pin – Front Axle	4
15	0090-0155	Cotter Pin – 3/16" x 1 3/4"	4
16	A-01030	Steering Cylinder – 4WD	1
17	A-01005	Front Axle Mount Weldment	1
18	0096-0038	Cap Screw, M20 x 120	2
19	0096-0045	Hex Nut, Self-Locking, M20	2
20	A-01029	Pad – Front Axle	2
21	0096-0091	Flat Head Cap Screw, M10 x 25	4
22	A-01009	Pin – 1.0" x 5.5"	1
23	A-00018	Pin Retainer – 1.0"	1
24	0096-0014	Cap Screw, M10 x 20	1

REAR AXLE ASSEMBLY

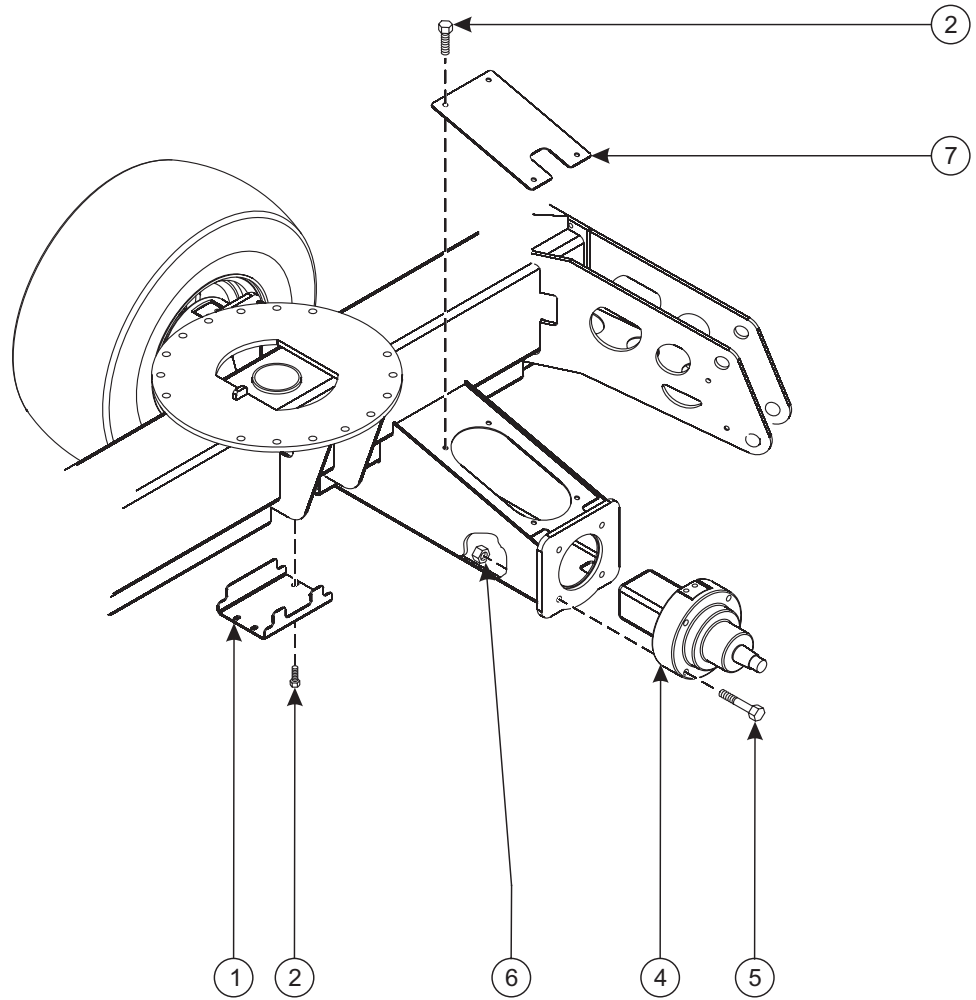

REAR AXLE ASSEMBLY PARTS LIST

Item No.	Part No.	Description	Qty.
1	A-00175	Hydraulic Cover	1
2	0096-0010	Cap Screw, M8 x 20	12
3	0096-0067	Clip Nut, M8	12
4	A-01032	Hydraulic Motor – Rear	2
5	0096-0024	Cap Screw, M12 x 100	8
6	0096-0042	Hex Nut, Self-Locking, M12	8
7	A-01037	Axle Cover	2

SLEW RING ASSEMBLY

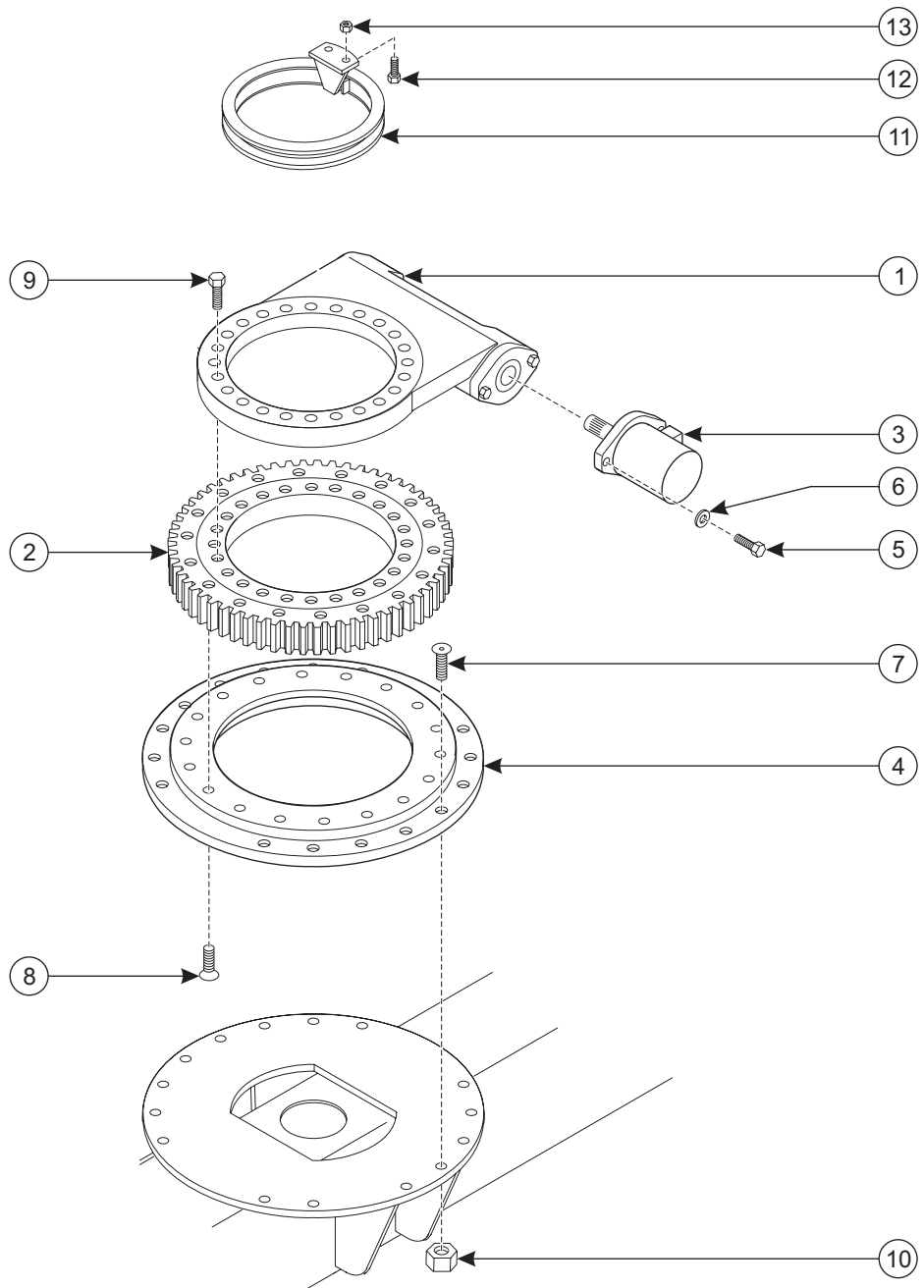

SLEW RING ASSEMBLY PARTS LIST

Item No.	Part No.	Description	Qty.
1	A-02189	Slew Assembly and Adapter	1
2		Slew Ring	1
3		Slew Ring Drive	1
4	A-00149	Base Ring Adapter	1
5	0090-0461	Cap Screw, 1/2-13 x 2	2
6	0090-0212	Lock Washer, 1/2	2
7	0096-0033	Flat Head Cap Screw, M16 x 35	16
8	0096-0054	Flat Head Cap Screw, M16 x 50	18
9	0090-0643	Cap Screw, 5/8-11 x 2-3/4, Grade 8	19
10	0096-0044	Hex Nut, Self-Locking, M16	16
11	A-00350	Rotation Stop Assembly	1
12	0096-0021	Cap Screw, M12 x 45	2
13	0096-0042	Hex Nut, Self-Locking, M12	2

COUNTERWEIGHT ASSEMBLY

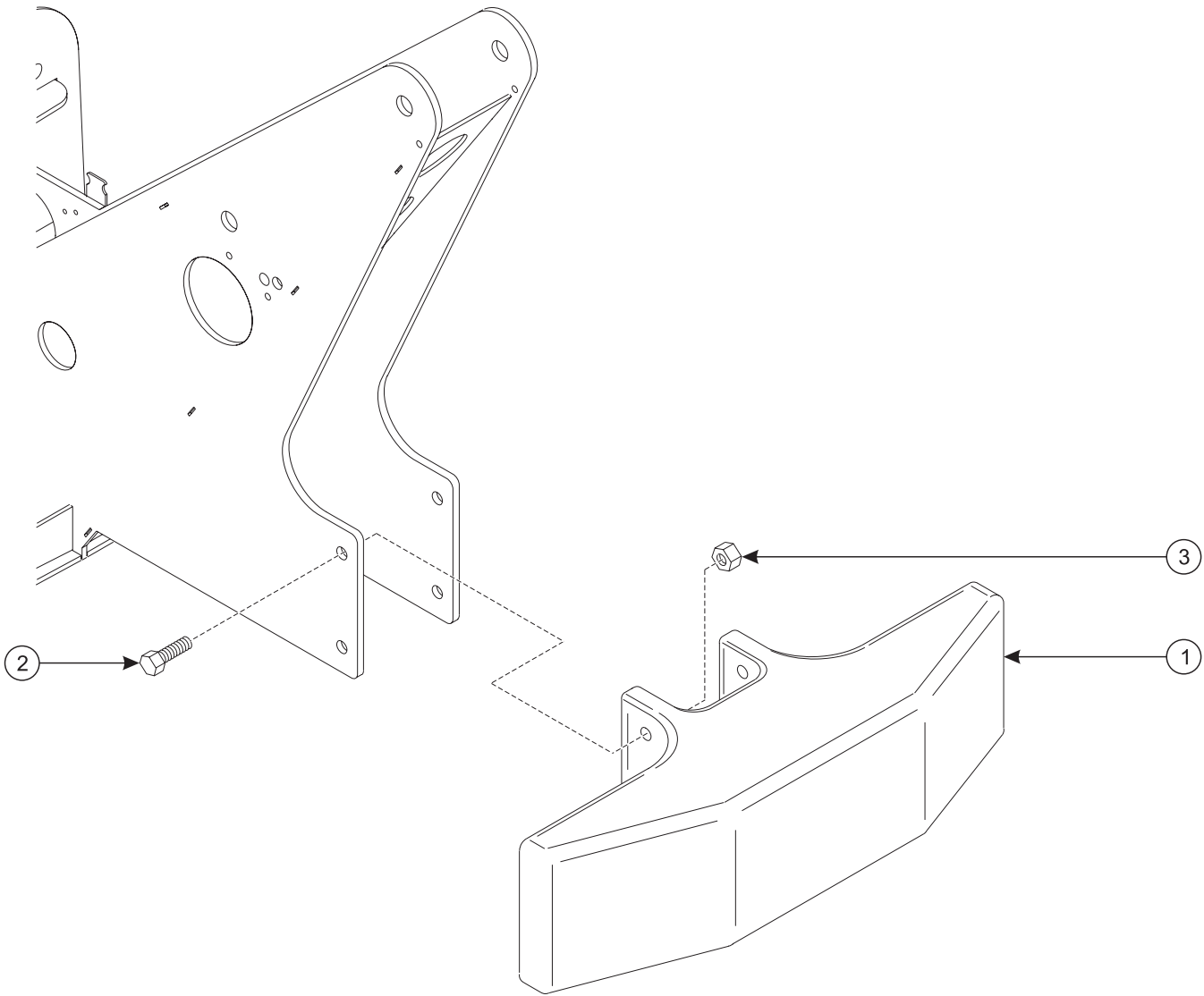

COUNTERWEIGHT ASSEMBLY PARTS LIST

Item No.	Part No.	Description	Qty.
1	A-00270	Counterweight	1
2	0096-0065	Cap Screw, M20 x 80	4
3	0096-0045	Hex Nut, Self-Locking, M20	4

CONTROL COMPARTMENT ASSEMBLY

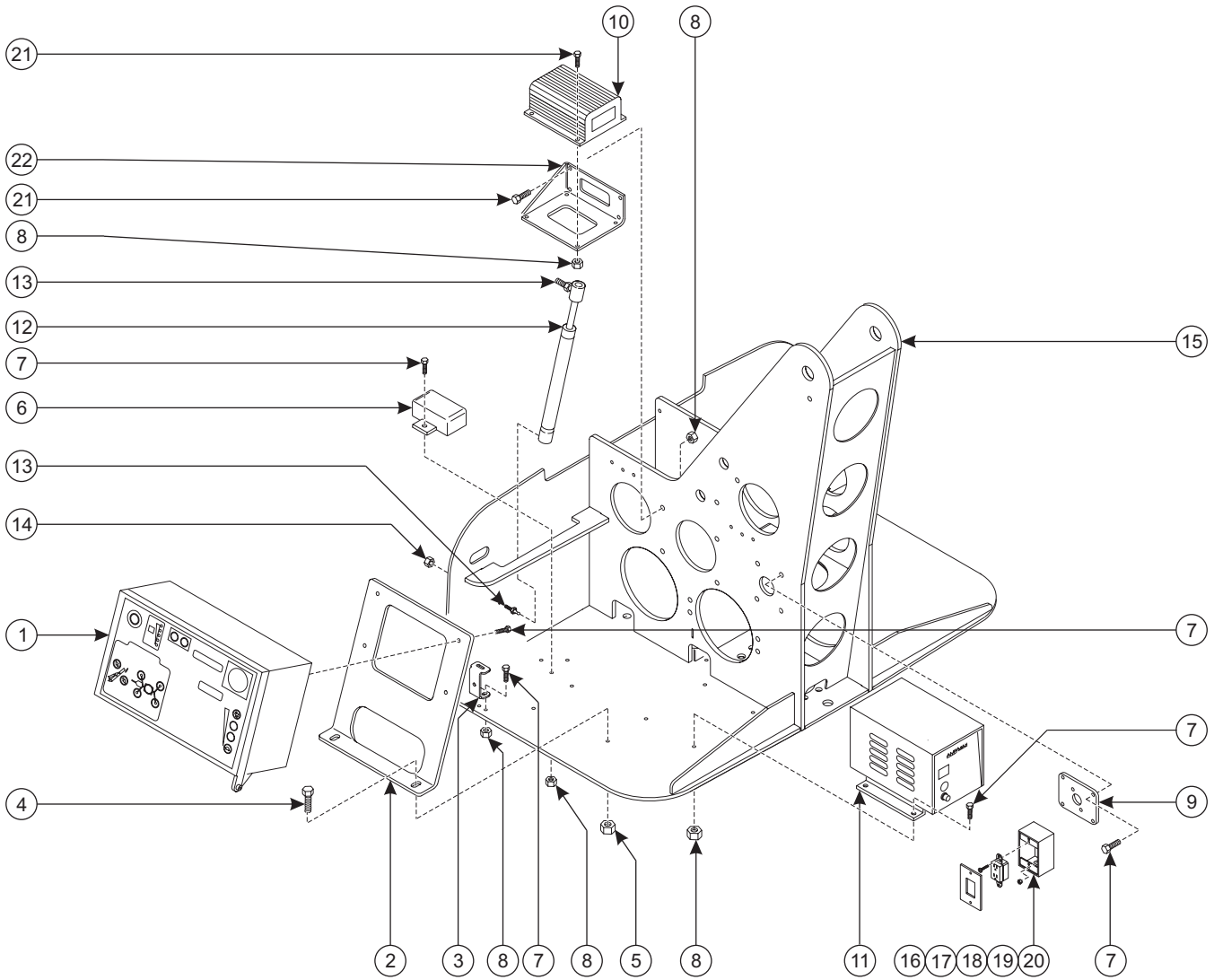

CONTROL COMPARTMENT ASSEMBLY PARTS LIST

Item No.	Part No.	Description	Qty.
1	A-00712	Lower Control Box	1
2	A-00233	Lower Control Mount	1
3	A-00290	Cover Stop Bracket	1
4	0096-0016	Cap Screw, M10 x 25	2
5	0096-0041	Hex Nut, Self-Locking, M10	2
6	A-00295	Level Sensor	1
7	0096-0002	Cap Screw, M6 x 20	16
8	0096-0039	Hex Nut, Self-Locking, M6	20
9	A-00287	Mount Plate – GFI Outlet	1
10	A-00255	Motor Controller	2
11	B01-05-0056	Battery Charger	1
12	A-00274	Gas Spring	1
13	0090-0920	Stud Ball, 10mm	2
14	0090-0185	Hex Nut, Self-Locking, 5/16-18	2
15	A-03200	Turntable Weldment	1
16	B01-10-0046	Outlet Box	1
17	B01-10-0034	GFI Outlet	1
18	B01-10-0035	Outlet Box Cover	1
19	0096-0001	Cap Screw, M6 x 16	2
20	A-00288	Plastic Cover	1
21	0096-0004	Cap Screw, M6 x 25	8
22	A-00935	Dual Motor Controller Bracket	1

PUMP COMPARTMENT ASSEMBLY

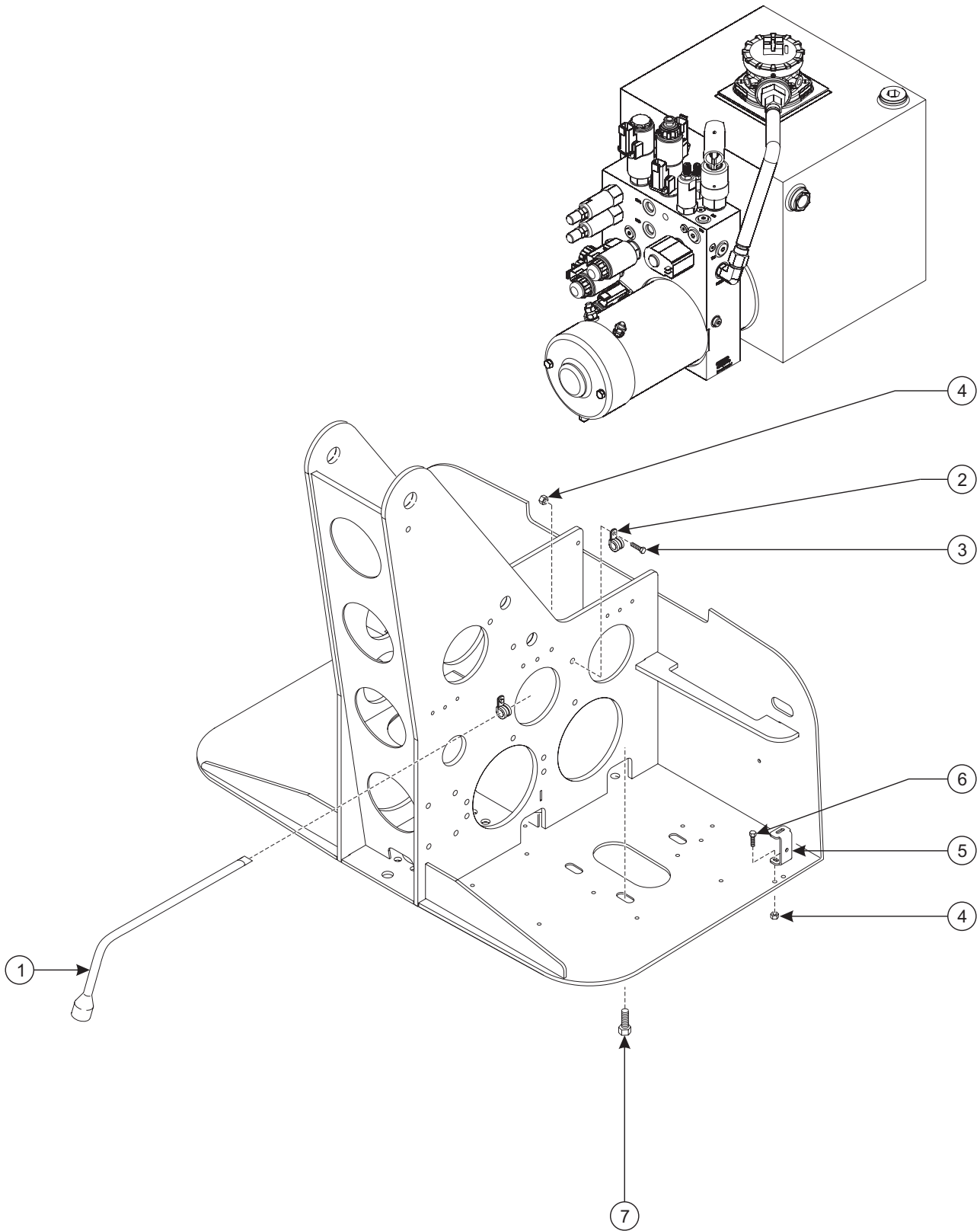

PUMP COMPARTMENT PARTS LIST

Item No.	Part No.	Description	Qty.
1	A-00268	Tire Iron/Jack Handle	1
2	B04-07-0033	Clamp	2
3	0096-0001	Cap Screw, M6 x 16	2
4	0096-0039	Hex Nut, Self-Locking, M6	4
5	A-00290	Cover Stop Bracket	1
6	0096-0002	Cap Screw, M6 x 20	2
7	0096-0014	Cap Screw, M10 x 20	2

BATTERY COMPARTMENT ASSEMBLY

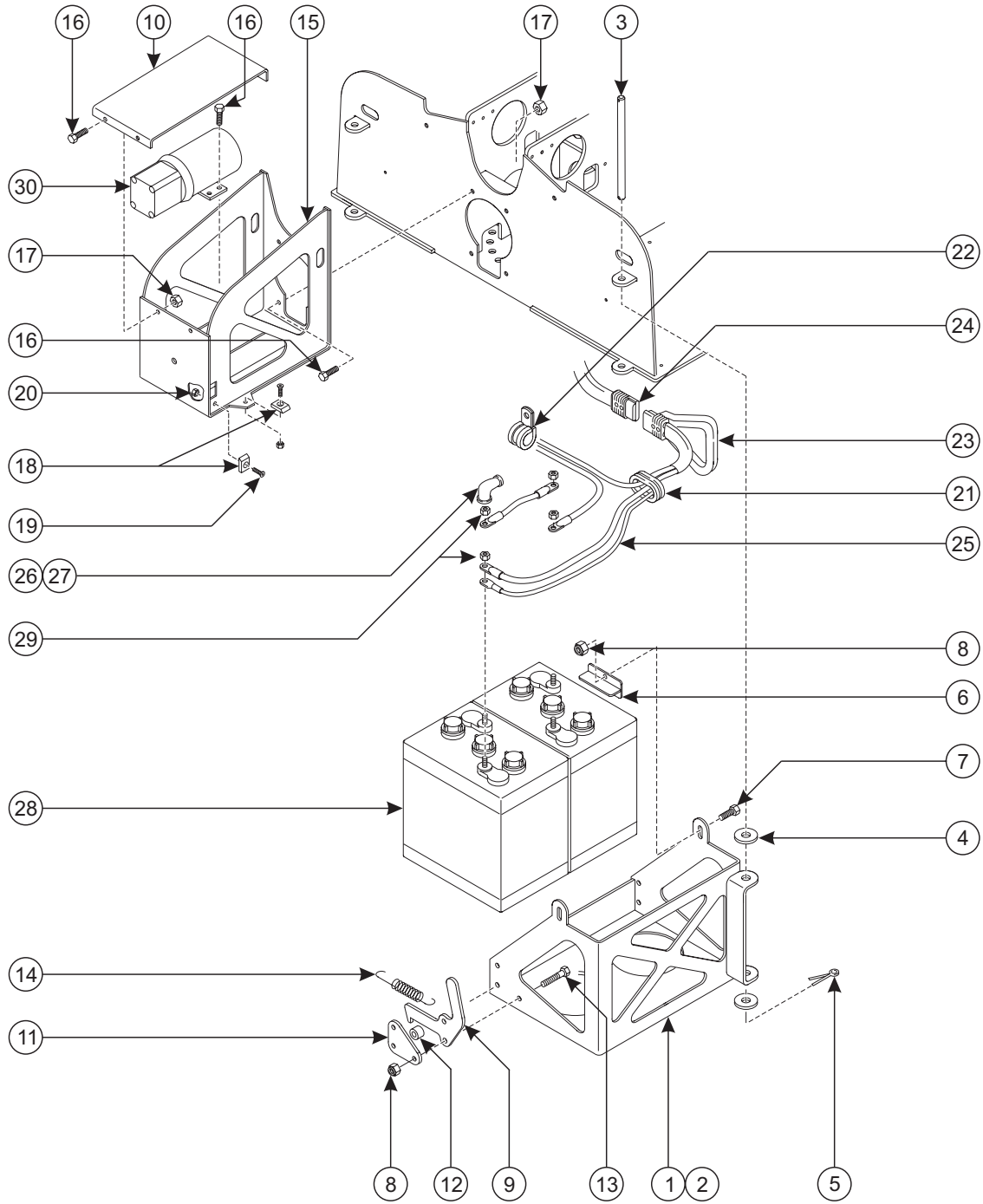

BATTERY COMPARTMENT ASSEMBLY PARTS LIST

Item No.	Part No.	Description	Qty.
1	A-00215	Battery Box Weldment – Left	1
2	A-00220	Battery Box Weldment – Right	1
3	A-00278	Battery Hinge Pin	2
4	0096-0050	Washer, Flat, M16	8
5	0090-0147	Cotter Pin	4
6	A-00271	Battery Clamp	4
7	0096-0010	Cap Screw, M8 x 20	4
8	0096-0040	Hex Nut, Self-Locking, M8	8
9	A-00219	Battery Box Latch	2
10	A-00256	Motor Cover	1
11	A-00229	Latch Plate	2
12	A-00234	Spacer	2
13	0096-0011	Cap Screw, M8 x 25	6
14	A-00244	Tension Spring	2
15	A-00225	Nose Weldment	1
16	0096-0014	Cap Screw, M10 x 20	10
17	0096-0041	Hex Nut, Self-Locking, M10	10
18	A-00037	Ramp, Short	4
19	0096-0002	Flat Head Cap Screw, M6 x 20	4
20	0096-0039	Hex Nut, Self-Locking, M6	4
21	A-00046	Grommet	4
22	B04-07-0036	Clamp	2
23	B01-09-0132	A-Frame Handle, Connector	1
24	B01-09-0131	Plug, Connector	1
25	A-03272	Battery Cable Kit	1
26	B01-09-0133	Terminal Boot – Black	4
27	B01-09-0134	Terminal Boot – Red	4
28	A-00242	Battery	4
29	0090-0162	Hex Nut, 3/8-16"	8
30	A-00235	Power Unit, 4WD	1
	B02-15-0528	3KW 24V DC Motor	1
	B02-15-0529	Gear Pump 2.0 ccm	1
	B02-02-0301	Fitting M14 x –6 ORFS	1
	B02-02-0302	Fitting, M18 x –8 ORFS	1

COVER ASSEMBLY

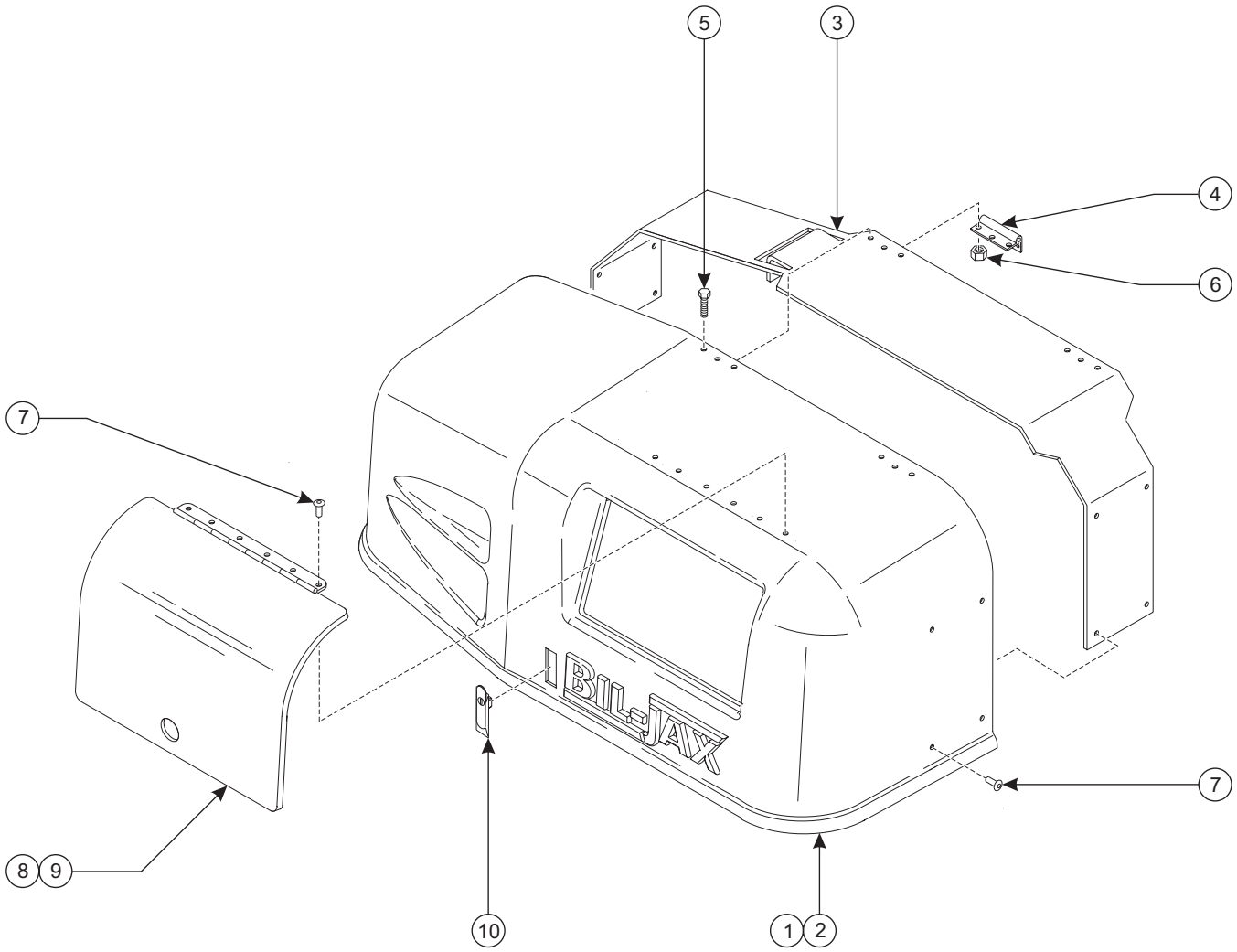

COVER ASSEMBLY PARTS LIST

Item No.	Part No.	Description	Qty.
1	A-03240	Cover – Left	1
2	A-03239	Cover – Right	1
3	A-00228	Cover Brace	2
4	A-00252	Hinge	4
5	0096-0002	Cap Screw, M6 x 20	12
6	0096-0039	Hex Nut, Self-Locking, M6	12
7	0090-1080	Pop Rivet	22
8	A-00258	Controls Cover – Left Side	1
9	B42-01-1002	Hinge, Controls Cover	1
10	A-00292	Cover Latch Assembly	2

BOOM ASSEMBLY (I)

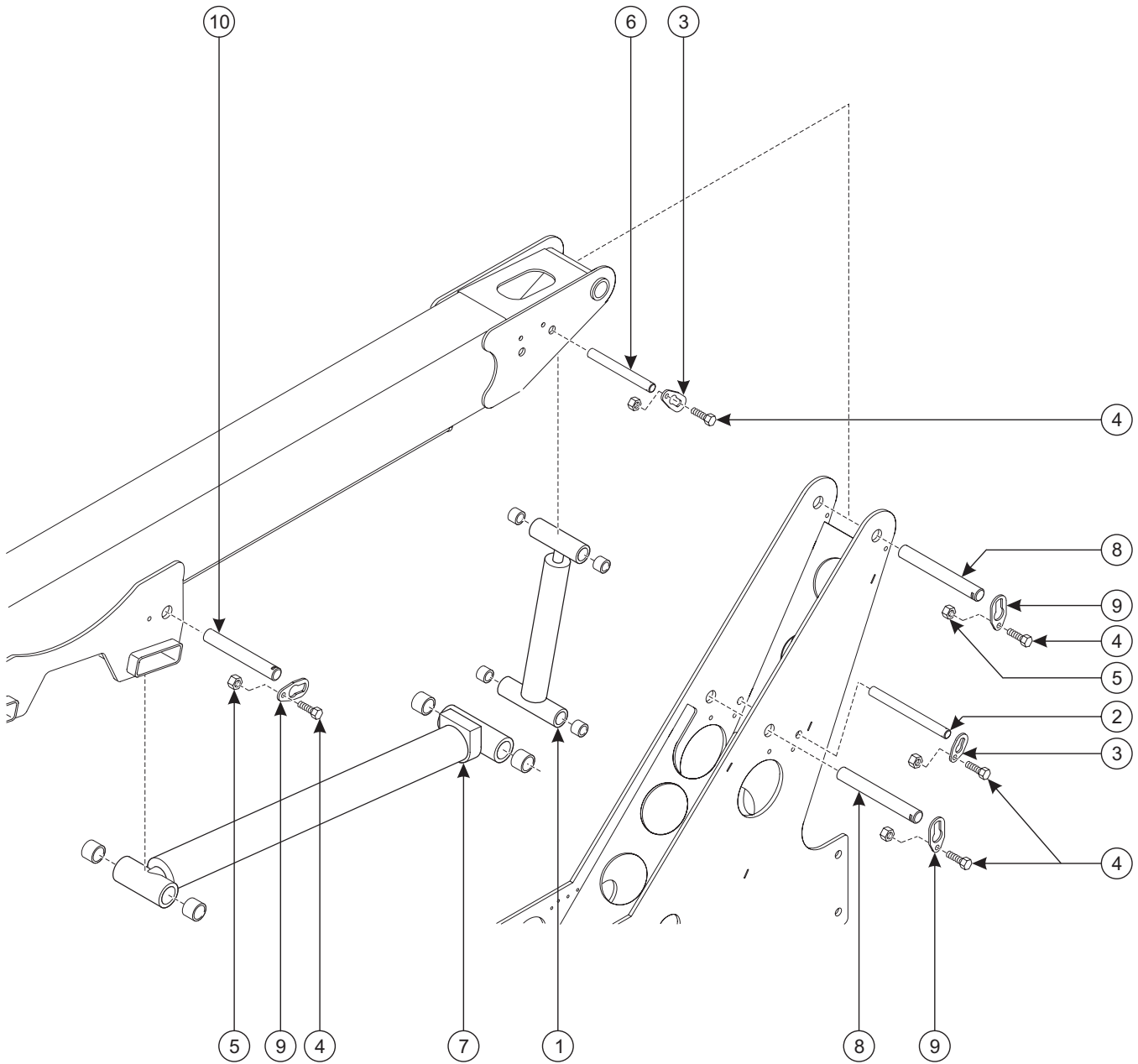

BOOM ASSEMBLY PARTS LIST

Item No.	Part No.	Description	Qty.
1	A-00552	Hydraulic Master Cylinder	1
2	A-00024	Pin, .75 x 8.5	1
3	A-00017	Pin Retainer – .75	2
4	0096-0016	Cap Screw, M10 x 25	7
5	0096-0041	Hex Nut, Self-Locking, M10	7
6	A-00026	Pin, .75 x 7.0	1
7	A-00551	Hydraulic Boom Cylinder	1
8	A-00021	Pin, 1.25 x 8.5	2
9	A-00019	Pin Retainer – 1.25	5
10	A-00023	Pin, 1.25 x 7.25	1

BOOM ASSEMBLY (II)

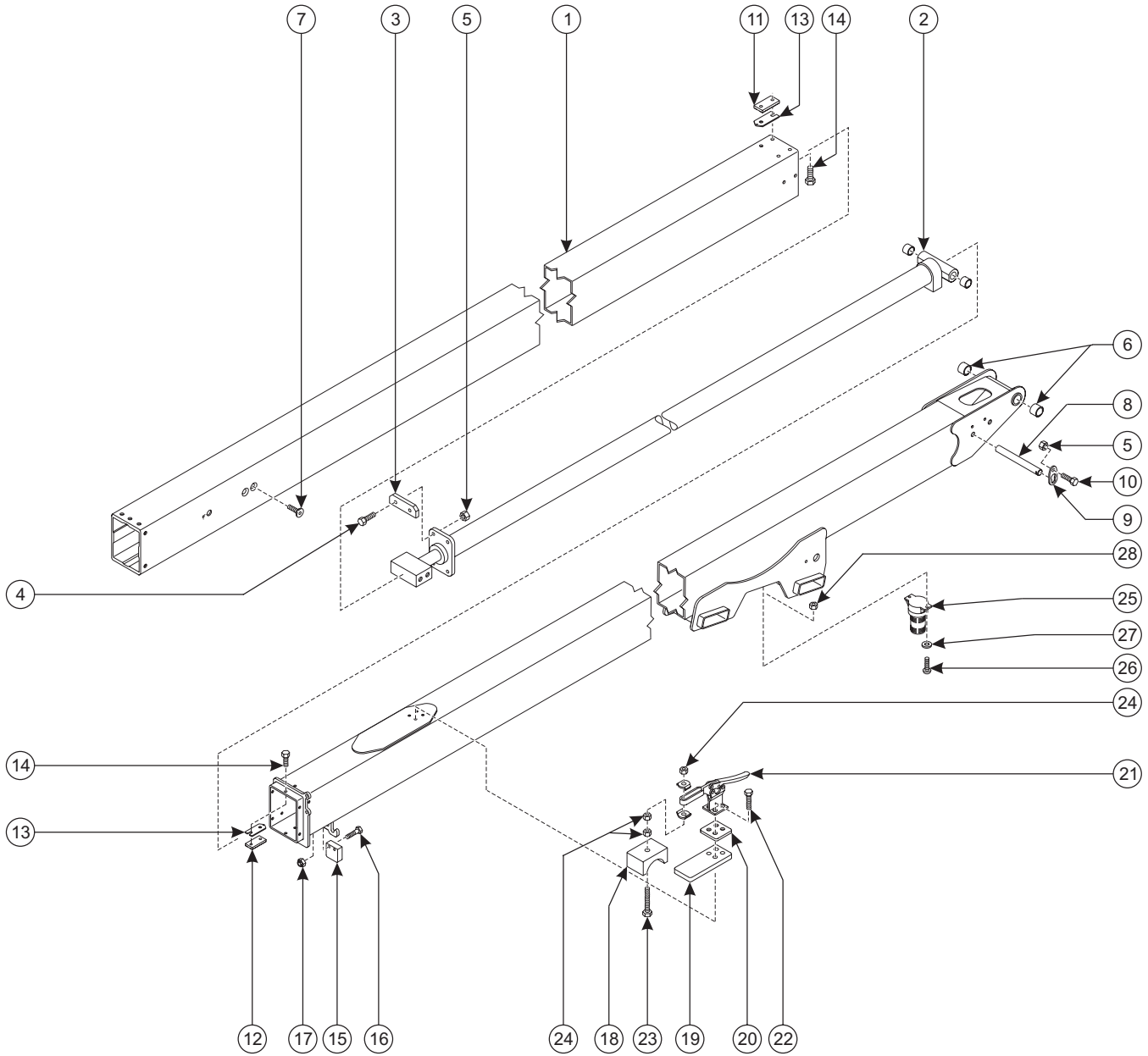

BOOM ASSEMBLY PARTS LIST

Item No.	Part No.	Description	Qty.
1	A-00510	Telescopic Boom Tube	1
2	A-00550	Hydraulic Extension Cylinder	1
3	A-00535	Slider	2
4	0096-0018	Cap Screw, M10 x 40	4
5	0096-0041	Hex Nut, Self-Locking, M10	
6	A-00032	Bearing	2
7	0096-0033	Flat Head Cap Screw, M16 x 35	4
8	A-00027	Pin, .75 x 7.0	1
9	A-00017	Retainer – .75	1
10	0096-0016	Cap Screw, M10 x 25	1
11	A-00533-1	Wear Pad – Green	5
12	A-00533-2	Wear Pad – Grey	7
13	A-00534	Wear Pad Shim	6
14	0096-0013	Nylon Cap Screw, M10 x 16	24
15	A-00537	Boom Switch Block	1
16	0096-0098	Cap Screw, M8 x 35	2
17	0096-0040	Hex Nut, Self-Locking, M8	2
18	A-00469	Cage Latch Pad	1
19	A-00470	Cage Storage Pad	1
20	A-00471	Cage Latch Plate	1
21	A-00473	Cage Latch	1
22	0096-0001	Cap Screw, M6 x 16	4
23	0096-0049	Cap Screw, M8 x 50	1
24	0096-0040	Hex Nut, Self-Locking, M8	3
25	B01-10-0275	Strobe Light (Option)	1
26	0090-0236	Machine Screw, #10-24 x 3/4	2
27	0090-0415	Washer, Flat, #10	2
28	0090-0182	Hex Nut, Self-Locking, #10-24	2

CABLE TRACK ASSEMBLY

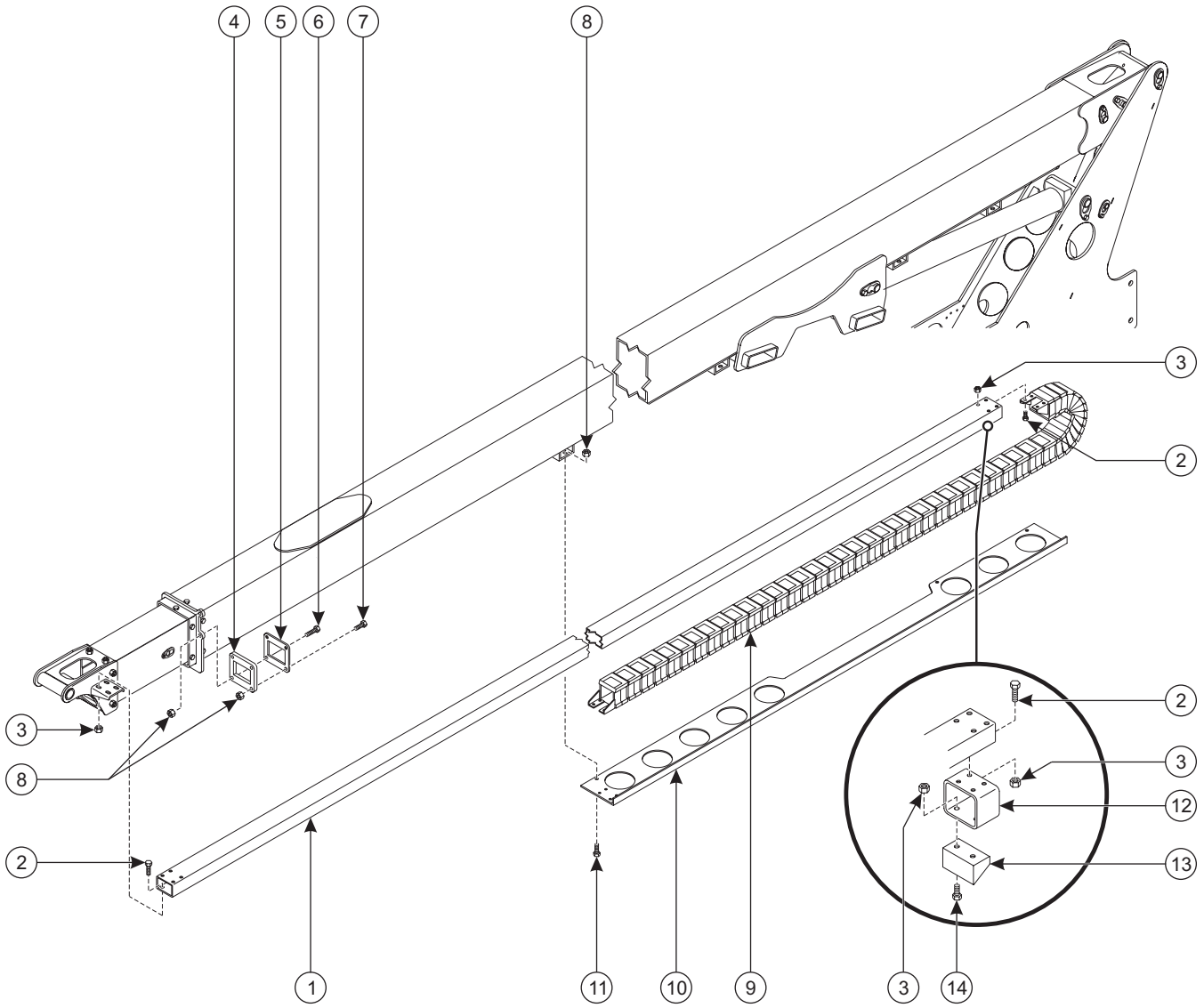

CABLE TRACK ASSEMBLY PARTS LIST

Item No.	Part No.	Description	Qty.
1	A-00531	Slide Tube	1
2	0096-0010	Cap Screw, M8 x 20	16
3	0096-0040	Hex Nut, Self-Locking, M8	18
4	A-00532	Tube Slider	1
5	A-00529	Tube Slider Back	1
6	0096-0018	Cap Screw, M10 x 40	2
7	0096-0017	Cap Screw, M10 x 30	2
8	0096-0041	Hex Nut, Self-Locking, M10	8
9	B00-00-0031	Cable Track – 41 Links	1
10	A-00536	Cable Track Tray	1
11	0096-0014	Cap Screw, M10 x 20	4
12	A-00538	Cable Support Tube	1
13	A-00539	Cable Slide Block	1
14	0096-0056	Cap Screw, M8 x 30	2

BOOM NOSE ASSEMBLY

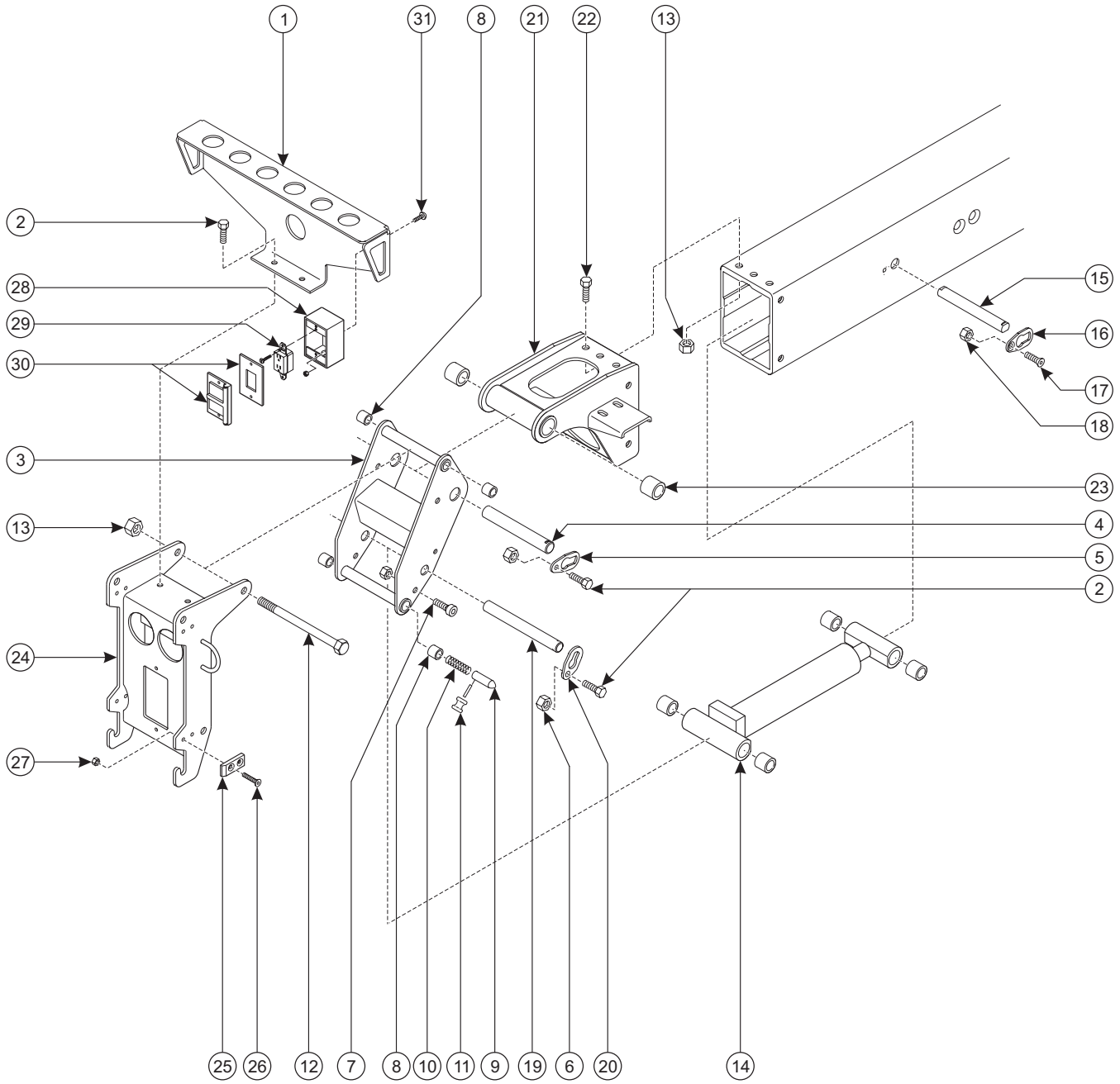

BOOM NOSE ASSEMBLY PARTS LIST

Item No.	Part No.	Description	Qty.
1	A-00979	Bulkhead Mount	1
2	0096-0016	Cap Screw, M10 x 25	4
3	A-00601	Platform Pivot Weldment	1
4	A-00025	Pin, 1.0 x 6.5	1
5	A-00018	Pin Retainer – 1.0	1
6	0096-0041	Hex Nut, Self-Locking, M10	6
7	0096-0015	Socket Head Cap Screw, M10 x 20	2
8	A-00033	Bearing	4
9	A-00606	Snap Pin	2
10	A-00608	Compression Spring	1
11	A-00609	Knob, Platform Latch	2
12	0096-0055	Cap Screw, M12 x 190	1
13	0096-0042	Hex Nut, Self-Locking, M12	10
14	A-00553	Hydraulic Slave Cylinder	1
15	A-00027	Pin, .75 x 5.25 DB	1
16	A-00034	Pin Retainer – .75 FH	2
17	0096-0012	Flat Head Cap Screw, M8 x 25	2
18	0096-0040	Hex Nut, Self-Locking, M8	2
19	A-00035	Pin, .75 x 6.5	1
20	A-00017	Pin Retainer – .75	1
21	A-00522	Boom End Weldment	1
22	0096-0020	Cap Screw, M12 x 30	9
23	A-00031	Bearing	2
24	A-00610	Platform Mount Weldment	1
25	A-00038	Ramp	4
26	0096-0003	Flat Head Cap Screw, M6 x 20	8
27	0096-0039	Hex Nut, Self-Locking, M6	10
28	B01-10-0046	Outlet Box	1
29	B01-10-0034	GFI Outlet	1
30	B01-10-0035	Outlet Box Cover	1
31	0096-0001	Cap Screw, M6 x 16	2

PLATFORM ASSEMBLY

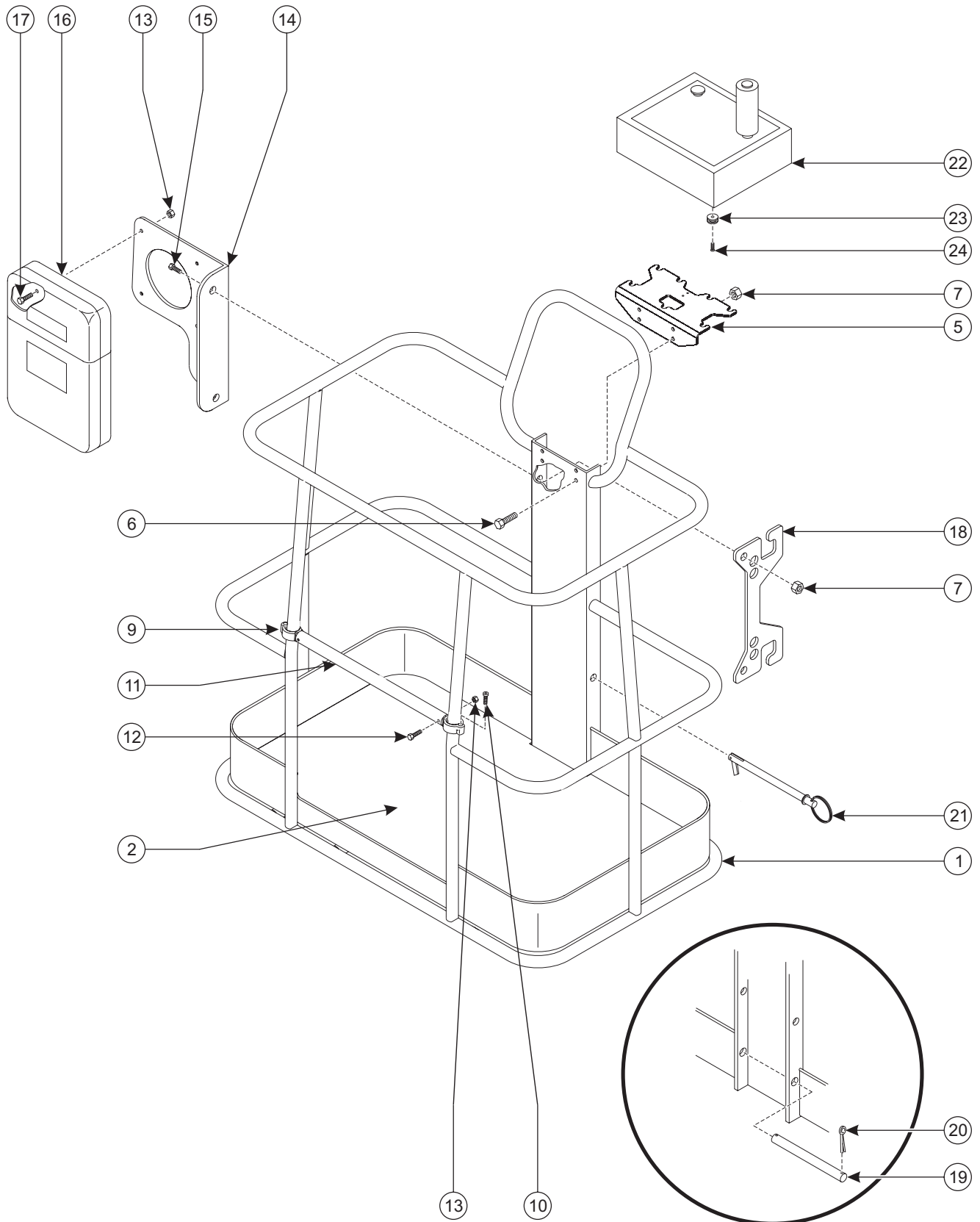

PLATFORM ASSEMBLY PARTS LIST

Item No.	Part No.	Description	Qty.
1	A-03350	Platform Weldment – 5'	1
2	A-03359	Platform Floor	1
3	0096-0102	Cap Screw, M8 x 25	26
4	0096-0040	Hex Nut, Self-Locking, M8	26
5	A-03361	Upper Control Box Mount	1
6	0096-0016	Cap Screw, M10 x 25	4
7	0096-0041	Hex Nut, Self-Locking, M10	4
8	A-00466	Control Box Latch	1
9	A-00463	Midrail End	4
10	0096-0115	Slotted Head Cap Screw, M6 x 20	2
11	A-00464	Midrail	1
12	0096-0052	Cap Screw, M6 x 40	2
13	0096-0039	Hex Nut, Self-Locking, M6	6
14	A-00468	Manual Storage Mount Plate	1
15	0096-0017	Cap Screw, M10 x 30	2
16	A-00475	Manual Storage Box	1
17	0096-0001	Cap Screw, M6 x 16	4
18	A-00474	Cord Wrap Bracket	1
19	A-00071	Platform Pin	1
20	0090-0147	Cotter Pin – 1/8 x 1 1/4	2
21	A-00028	Pin – Platform to End Weldment	1
22	A-00779	Upper Control Box – 4WD Articulating	1
23	A-00462	Spool	7
24	0096-0003	Flat Head Cap Screw, M6 x 40	7

PUMP ASSEMBLY (A-00254)

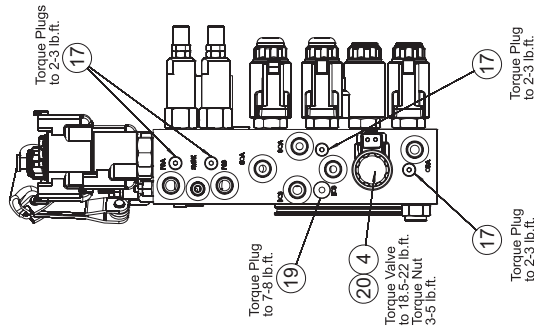
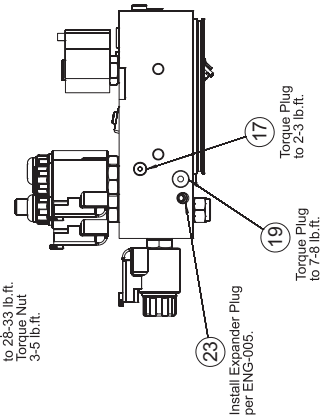
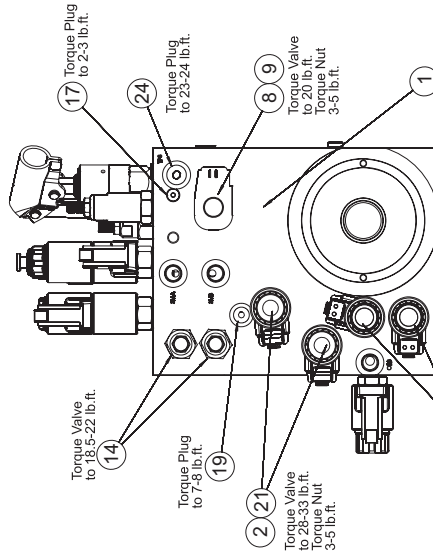
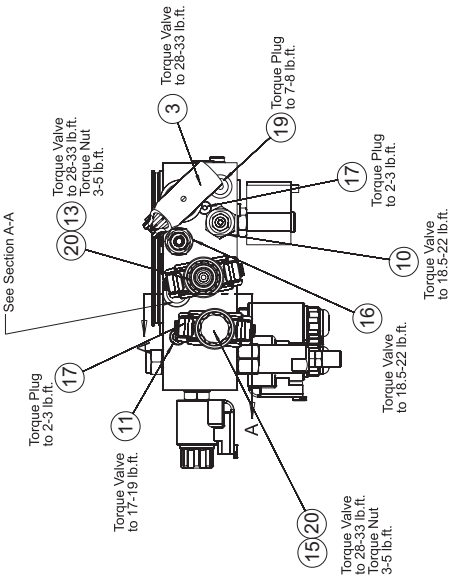
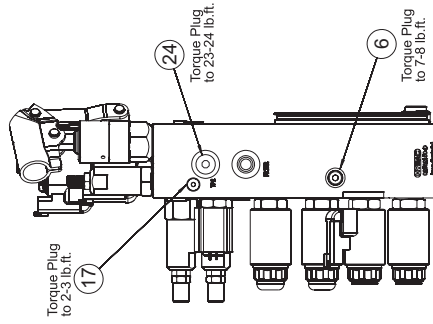
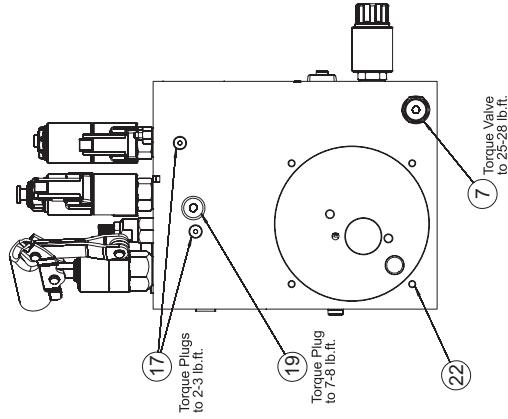
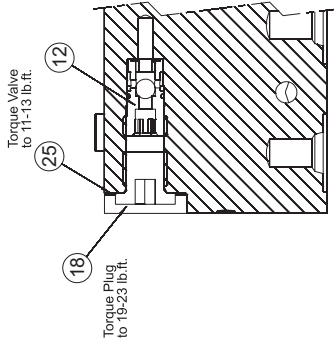

PUMP ASSEMBLY PARTS LIST

Item No.	Part No.	Description	Qty.
1	B02-15-0496	Manifold, Valve Housing	1
2	B02-14-0108	Valve, Counterbalance	2
3	B02-15-0472	Manual Pump, Extend/Retract/Rotate	1
4	B02-14-0089	Valve, Cartridge (Outrigger Check)	1
5	B02-14-0109	Valve, Cartridge (Outrigger)	2
6	B02-14-0091	Valve, Check	1
7	B02-14-0110	Valve, Check	1
8	B02-14-0094	Valve, Proportional	1
9	B02-14-0095	Coil Sterling, Proportional Valve	1
10	B02-14-0111	Valve, Relief	1
11	B02-14-0097	Valve, Relief	1
12	B02-14-0098	Valve, Shuttle	1
13	B02-14-0099	Valve, Cartridge (Rotator)	1
14	B02-14-0100	Valve, Counterbalance	1
15	B02-14-0101	Valve, Cartridge (Basket Compensate)	1
16	B02-14-0114	Valve, Flow Control (Rotator)	1
17	B02-02-0245	Fitting, Plug, #2 ORB	11
18	B02-02-0246	Fitting, Hex Plug	1
19	B02-02-0248	Fitting, Plug, #4 ORB	5
20	B02-14-0112	Coil, 20 VDC, #8	5
21	B02-14-0113	Coil, 20 VDC, #10	5
22	B02-15-0497	Stud, #1/4-20 x 5/8	4
23	B02-15-0498	Expansion Plug	1
24	B02-02-0235	Fitting, Plug, #6 ORB	2
25	B02-15-0478	Seal Ring	1

PUMP ASSEMBLY, CONTINUED

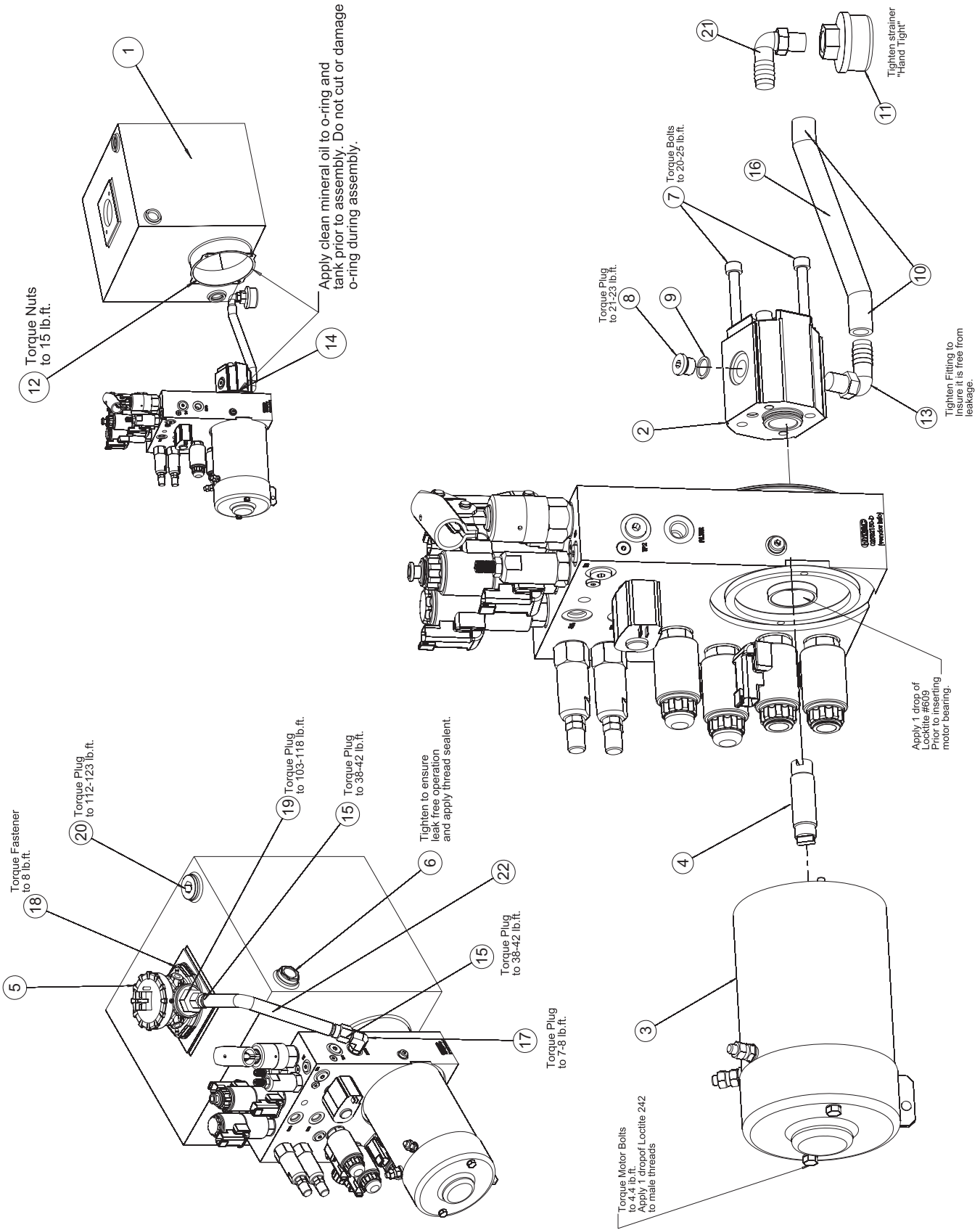

PUMP ASSEMBLY PARTS LIST, CONTINUED

Item No.	Part No.	Description	Qty.
1	B02-15-0513	Reservoir	1
2	B02-15-0470	Pump Assembly, 2.09 CCM	1
3	B02-15-0471	Motor, Pump, 24 VDC	1
4	B02-15-0500	Coupling, .875 x 2.795	1
5	B02-15-0501	Filter, Hydraulic	1
6	B02-15-0476	Sight Glass	1
7	B02-15-0477	Socket Head Cap Screw, M8 x 85	2
8	B02-02-0247	Fitting, Plug, M14 x 1.5 x 5.8	1
9	B02-15-0478	Seal Ring	1
10	B02-15-0485	Clamp, Band, #10-16	2
11	B02-15-0480	Filter, Suction	1
12	B02-15-0504	Allen Nut, 1/4-20	4
13	B02-02-0255	Fitting, M18 x HB-90M x HB-90	1
14	B02-15-0503	O-Ring, 110.72 x 3.53 NBR 70 D	1
15	B02-02-0279	Fitting, JIC-8 x Push On FS x PO	2
16	B02-15-0505	Hose, Black, 1/2 x 6"	1
17	B02-02-0280	Fitting, JIC-8 x #6 MxM	1
18	B02-15-0506	Cap Screw, #5/16-18 x 1 1/4	2
19	B02-02-0283	Fitting, JIC-8 x G 3/4 MxM	1
20	B02-02-0281	Fitting, Plug, #12 ORB	2
21	B02-02-0282	Fitting, 3/8 NPT x 1/2 MxHB	1
22	B02-15-0507	Hose, Black, 1/2 x 15"	1
	B02-02-0276	Fitting, Plug, #8 ORB (Under Reservoir)	1

BOOM AND ROTATION HYDRAULIC LINES (A-00269)

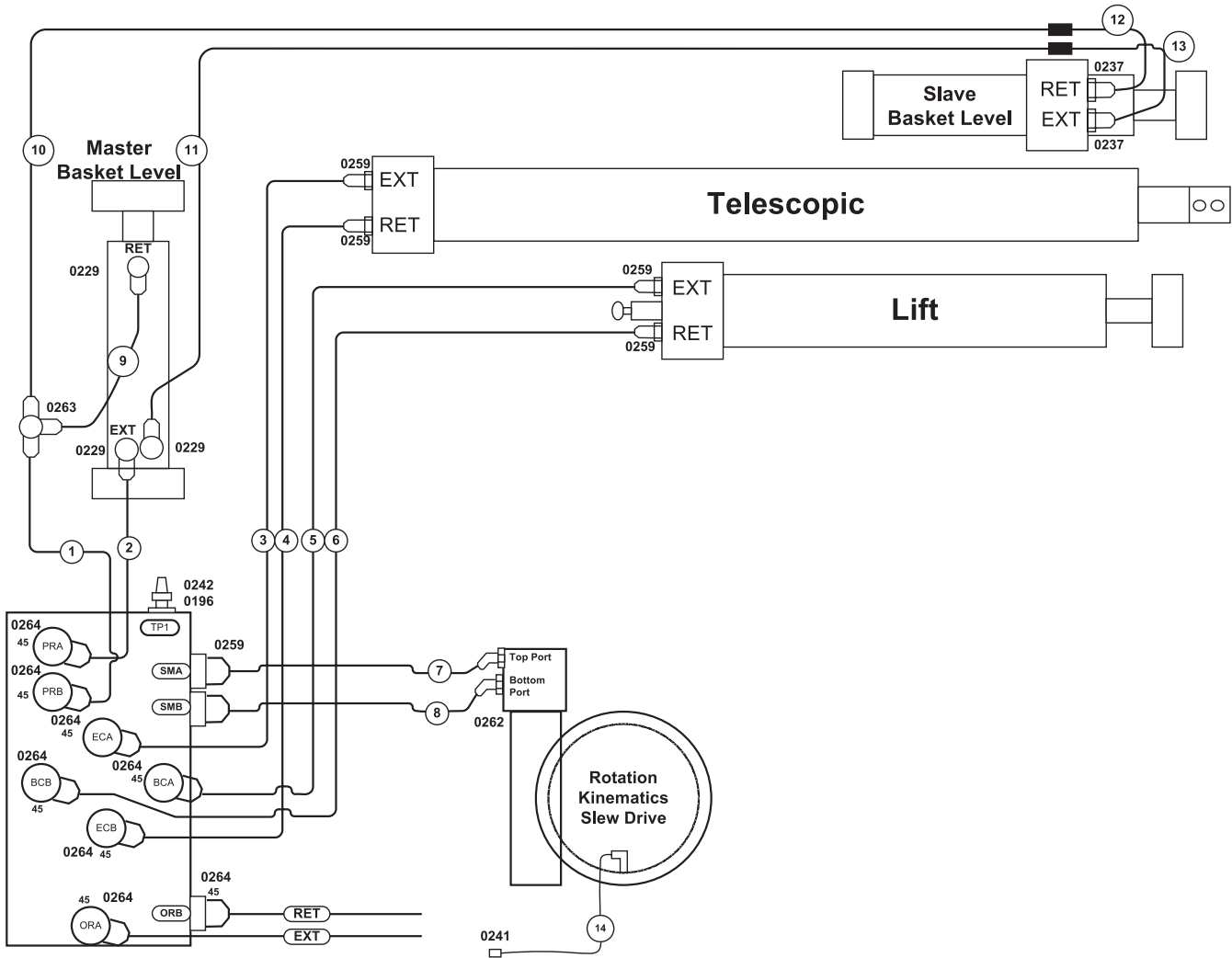

BOOM AND ROTATION HYDRAULIC LINES PARTS LISTS

Item No.	Part No.	Description	Fittings	
1	B02-01-0274	#4 x 42" Hydraulic Hose	4-6 FFORX	4-4 FFORX
2	B02-01-0275	#4 x 42" Hydraulic Hose	4-6 FFORX	4-4 FFORX
3	B02-01-0276	#6 x 66" Hydraulic Hose	6-6 FFORX	6-6 FFORX
4	B02-01-0277	#6 x 66" Hydraulic Hose	6-6 FFORX	6-6 FFORX
5	B02-01-0278	#4 x 48" Hydraulic Hose	4-6 FFORX	4-6 FFORX 45
6	B02-01-0279	#4 x 48" Hydraulic Hose	4-6 FFORX	4-6 FFORX 45
7	B02-01-0280	#4 x 36" Hydraulic Hose	4-6 FFORX	4-6 FFORX
8	B02-01-0281	#4 x 36" Hydraulic Hose	4-6 FFORX	4-6 FFORX
9	B02-01-0231	#4 x 10" Hydraulic Hose	4-4 FFORX 90S	4-4 FFORX
10	B02-01-0232	#4 x 420" Hydraulic Hose	4-4 FFORX	4-4 FFORX
11	B02-01-0233	#4 x 420" Hydraulic Hose	4-4 FFORX	4-4 FFORX
12	B02-01-0234	#4 x 16" Hydraulic Hose	4-4 MFFOR	4-4 FFORX
13	B02-01-0235	#4 x 16" Hydraulic Hose	4-4 MFFOR	4-4 FFORX
14	B02-01-0204	#3 x 32" Hydraulic Hose	2 MNPT	2 MNPT 90SW

FITTINGS

Part No.	Description	Qty.
B02-02-0259	#6 MORFS - #6 MORB, STR	6
B02-02-0264	#6 MORFS - # 6 MORB, 45°	8
B02-02-0263	#4 MORFS, Tee	1
B02-02-0237	#4 MORFS - #6 MORB, STR	2
B02-02-0262	#6 MORFS - #10 MORB, 45°	2
B02-02-0196	#4 MORB - #2 MNPT, STR	1
B02-02-0241	#2 NPTFM Coupling	1
B02-02-0242	#2 QD Plug	1
B02-02-0229	#4 MORFS - #6 MORB 90	3

OUTRIGGER HYDRAULIC LINES (A-03182)

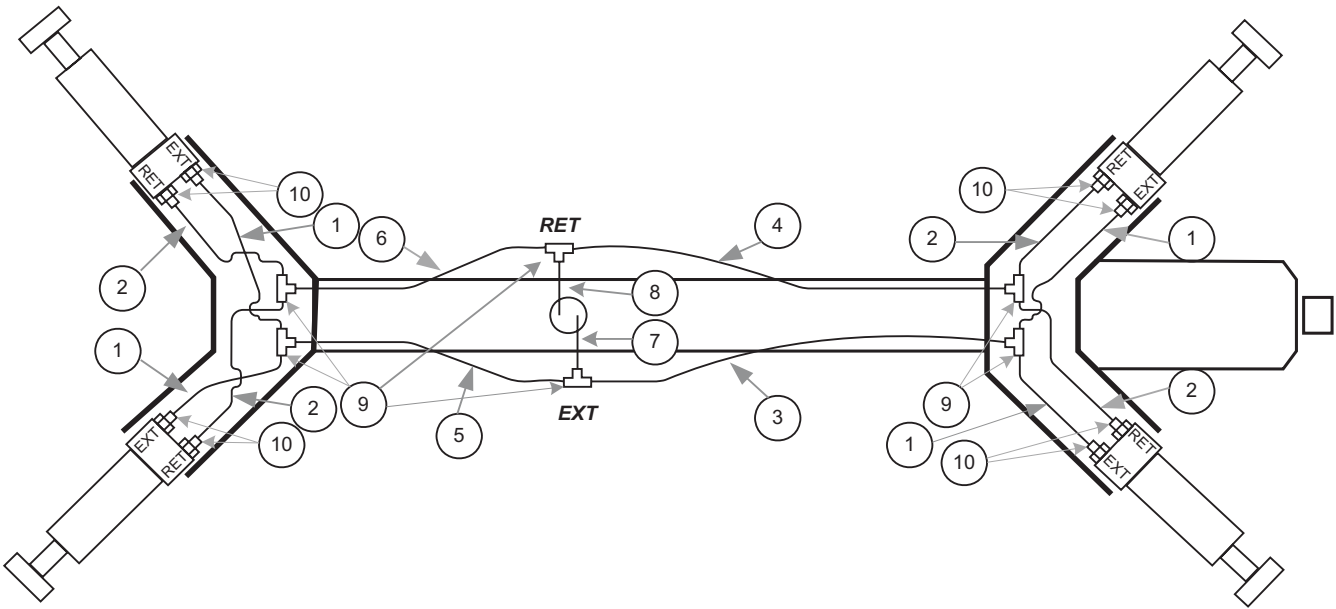

OUTRIGGER HYDRAULIC LINES PARTS LIST

Item No.	Part No.	Description	Qty.
1	B02-01-0213	#4 x 28" Hydraulic Hose	4
2	B02-01-0214	#4 x 28" Hydraulic Hose	4
3	B02-01-0215	#6 x 56" Hydraulic Hose	1
4	B02-01-0216	#6 x 56" Hydraulic Hose	1
5	B02-01-0219	#6 x 28" Hydraulic Hose	1
6	B02-01-0220	#6 x 28" Hydraulic Hose	1
7	B02-01-0327	#6 x 46" Hydraulic Hose	1
8	B02-01-0328	#6 x 46" Hydraulic Hose	1
9	B02-02-0258	Fitting, Tee, #6 MORFS	6
10	B02-02-0259	Fitting, #6 MORFS - #6 MORB	8

TRAILER HYDRAULIC LINES – 4WD (A-01075)

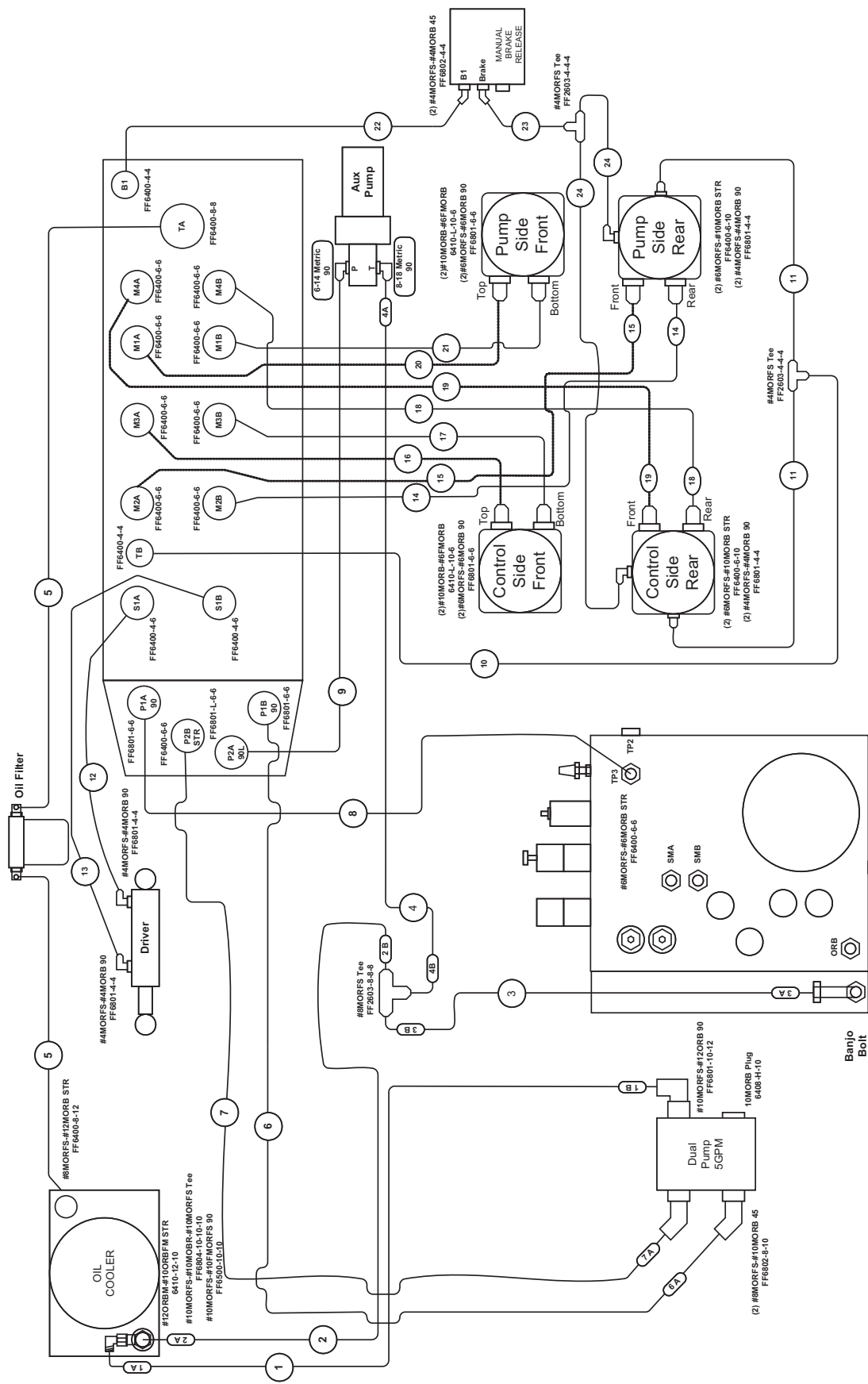

TRAILER HYDRAULIC LINES PARTS LISTS

Item No.	Part No.	Description
1	B02-01-0402	#10 x 28" Hydraulic Hose
2	B02-01-0401	#8 x 154" Hydraulic Hose
3	B02-01-0398	#8 x 16" Hydraulic Hose
4	B02-01-0400	#8 x 24" Hydraulic Hose
5	B02-01-0399	#8 x 18" Hydraulic Hose
6	B02-01-0386	#6 x 30" Hydraulic Hose
7	B02-01-0387	#6 x 30" Hydraulic Hose
8	B02-01-0397	#6 x 166" Hydraulic Hose
9	B02-01-0396	#6 x 150" Hydraulic Hose
10	B02-01-0385	#4 x 118" Hydraulic Hose
11	B02-01-0379	#4 x 16" Hydraulic Hose
12	B02-01-0382	#4 x 30" Hydraulic Hose
13	B02-01-0383	#4 x 40" Hydraulic Hose
14	B02-01-0393	#6 x 138" Hydraulic Hose
15	B02-01-0392	#6 x 138" Hydraulic Hose
16	B02-01-0388	#6 x 38" Hydraulic Hose
17	B02-01-0389	#6 x 38" Hydraulic Hose
18	B02-01-0395	#6 x 138" Hydraulic Hose
19	B02-01-0394	#6 x 138" Hydraulic Hose
20	B02-01-0390	#6 x 62" Hydraulic Hose
21	B02-01-0391	#6 x 62" Hydraulic Hose
22	B02-01-0380	#4 x 21" Hydraulic Hose
23	B02-01-0384	#4 x 105" Hydraulic Hose
24	B02-01-0381	#4 x 25" Hydraulic Hose

FITTINGS

Part No.	Description	Qty.
B02-02-0259	#6 MORFS - #6 MORB, STR	10
B02-02-0293	#8 MORFS - #8 MORB, STR	1
B02-02-0260	#6 MORFS - #6 MORB, 90°	6
B02-02-0287	#4 MORFS - #4 MORB, STR	2
B02-02-0288	#4 MORFS - #4 MORB, 90°	6
B02-02-0289	#4 MORFS, Tee	2
B02-02-0294	#6 MORFS - #6 MORB, 90°L	1
B02-02-0295	#12 MORB - #10 FMORB	1
B02-02-0296	#10 MORFS - #10 MORB - #10 MORFS, Tee	1
B02-02-0297	#10 MORFS - #10 FMORFS, 90°	1
B02-02-0298	#8 MORFS - #12 MORB, STR	1
B02-02-0299	#8 MORFS - #10 MORB, 45°	2
B02-02-0300	#10 MORFS - #12 MORB, 90°	1
B02-02-0303	#10 MORB Plug	1
B02-02-0304	#10 MORB - #6 FMORB	4
B02-02-0305	#6 MORFS - #10 MORB, STR	4
B02-02-0237	#4 MORFS - #6 MORB, STR	2
B02-02-0307	#8 MORFS, Tee	1
B02-02-0308	#4 MORB Plug	1
B02-02-0309	#8MORFS - #12 MORB, 90°	2

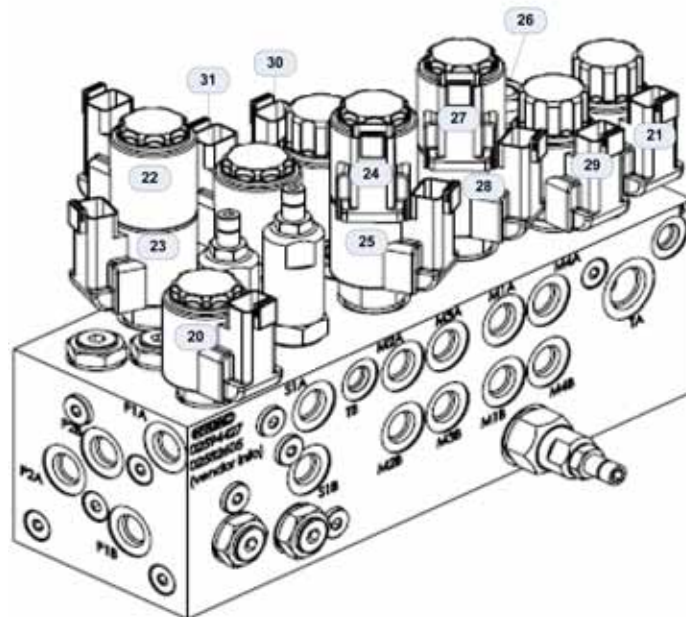

4WD MANIFOLD (A-01033)

WIRE HARNESSSES

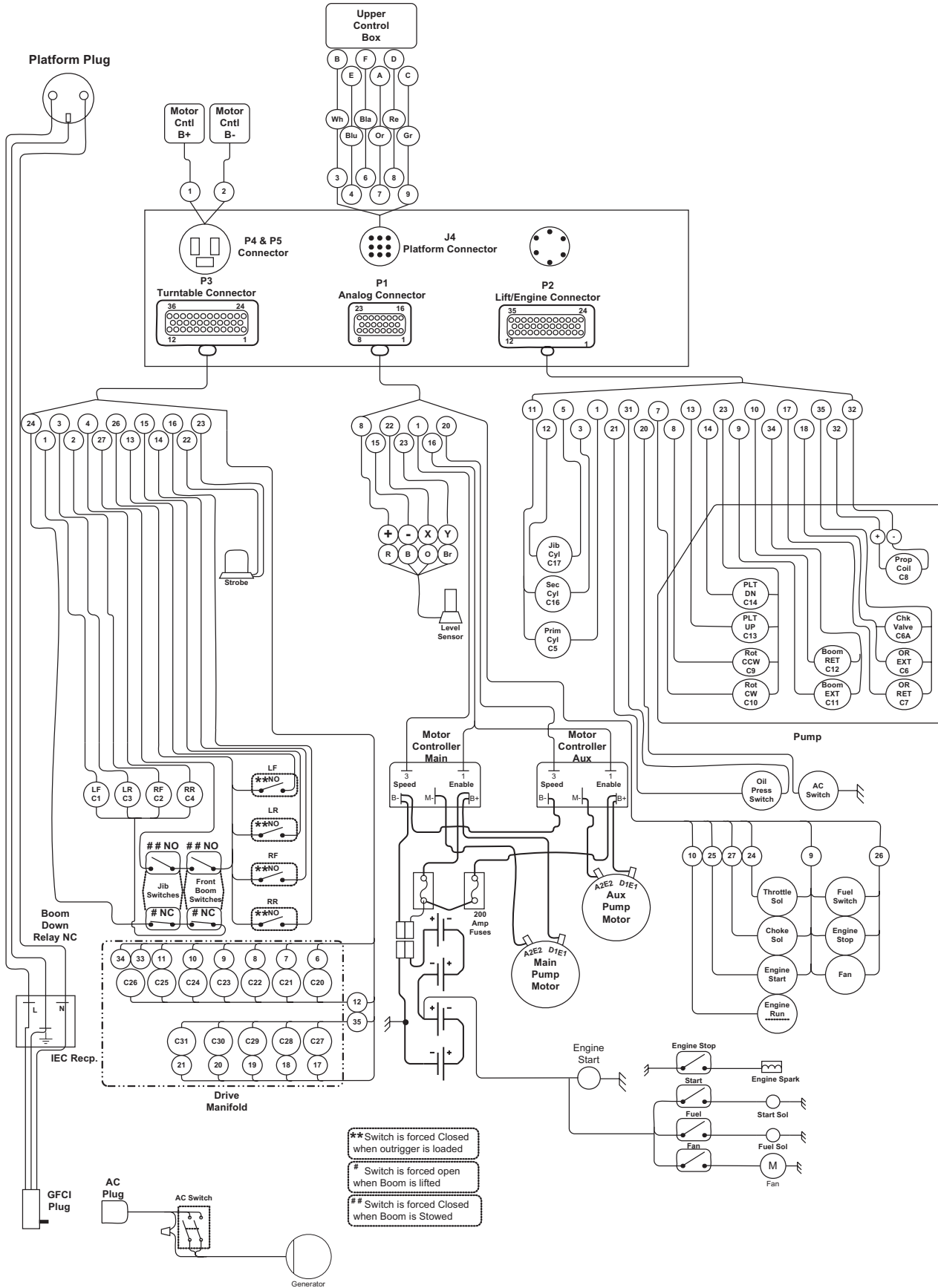

MANIFOLD WIRE HARNESS (A-00785)

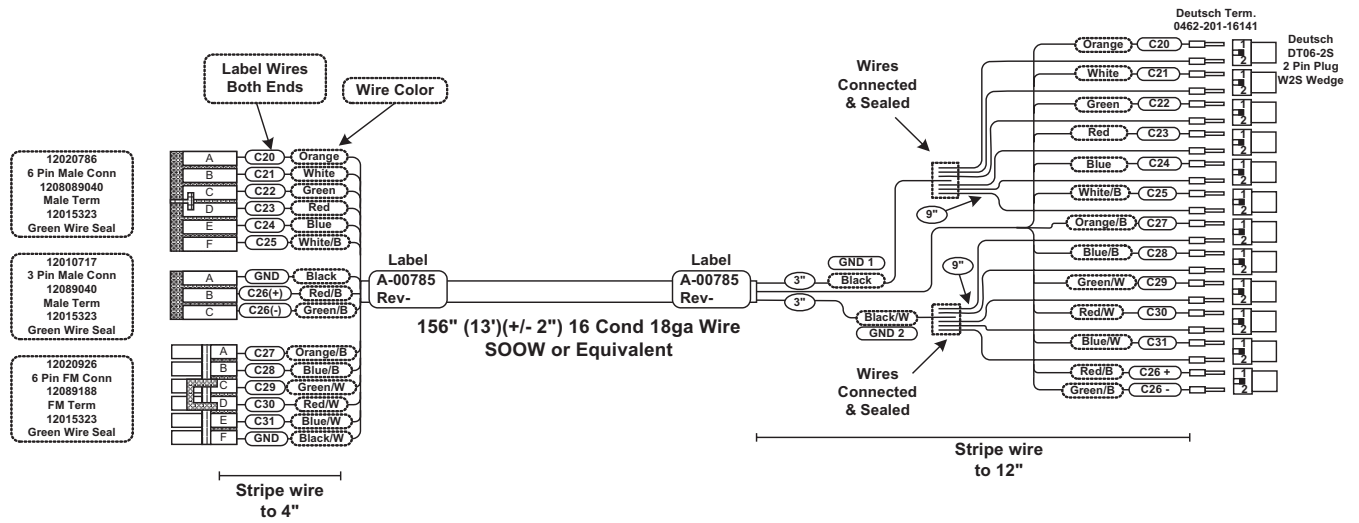

GAS ENGINE WIRE HARNESS (A-01034)

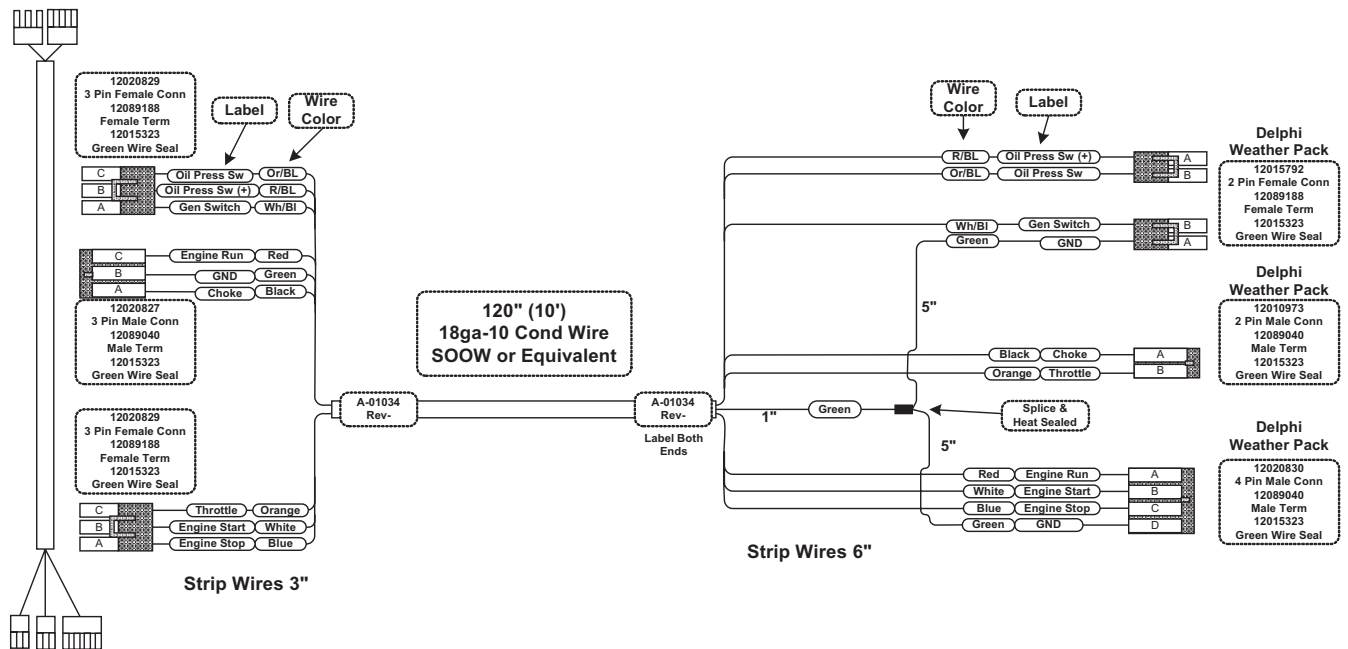

CHOKE /THROTTLE SOLENOID WIRE HARNESS (A-01042)

Weather Pack
FM Term
12089188
Cable Seal
12015323
FM Housing
12015792

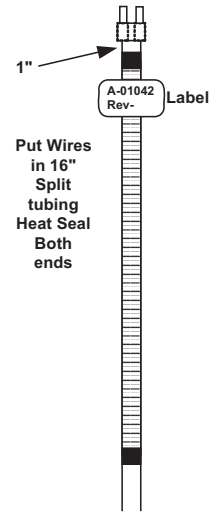
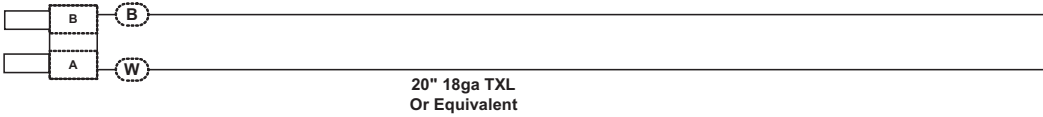

ENGINE RELAYS WIRE HARNESS (A-01044)

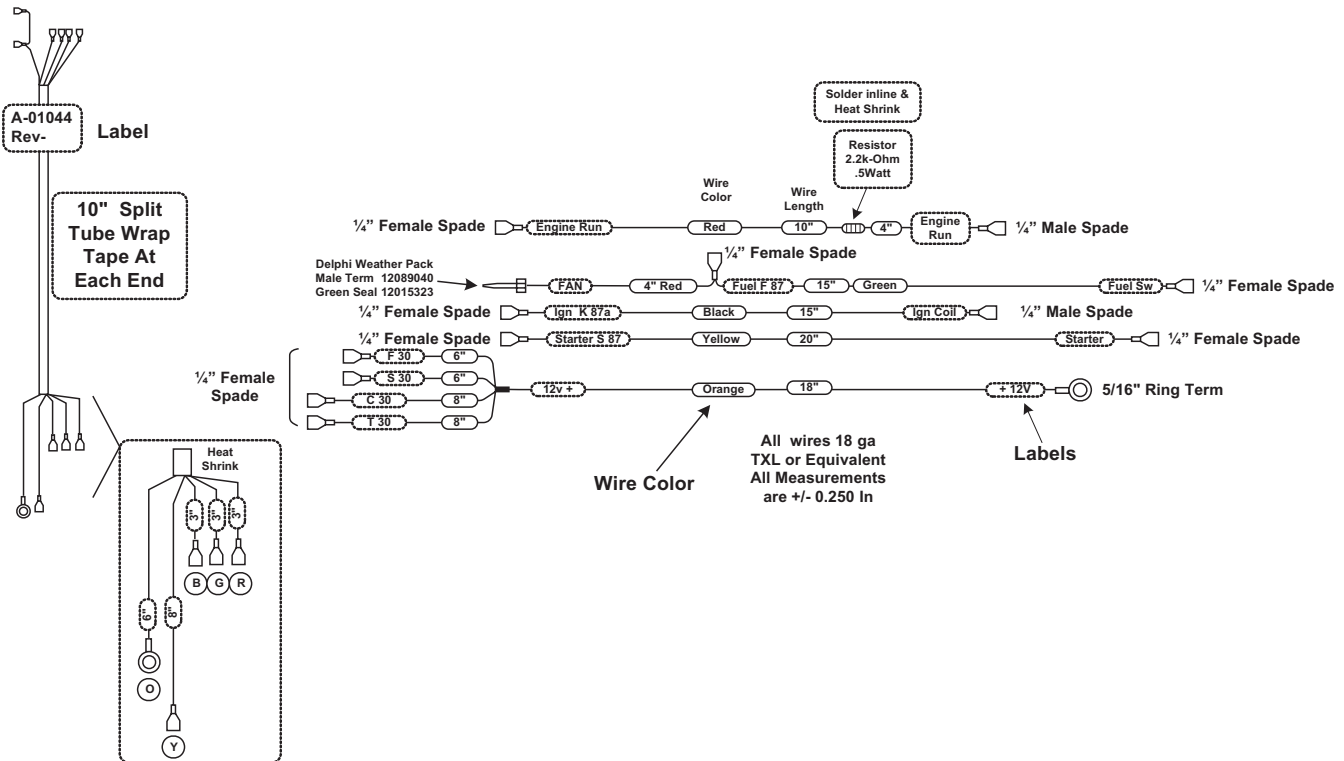

GENERATOR SWITCHER BOX ASSEMBLY (A-03040)

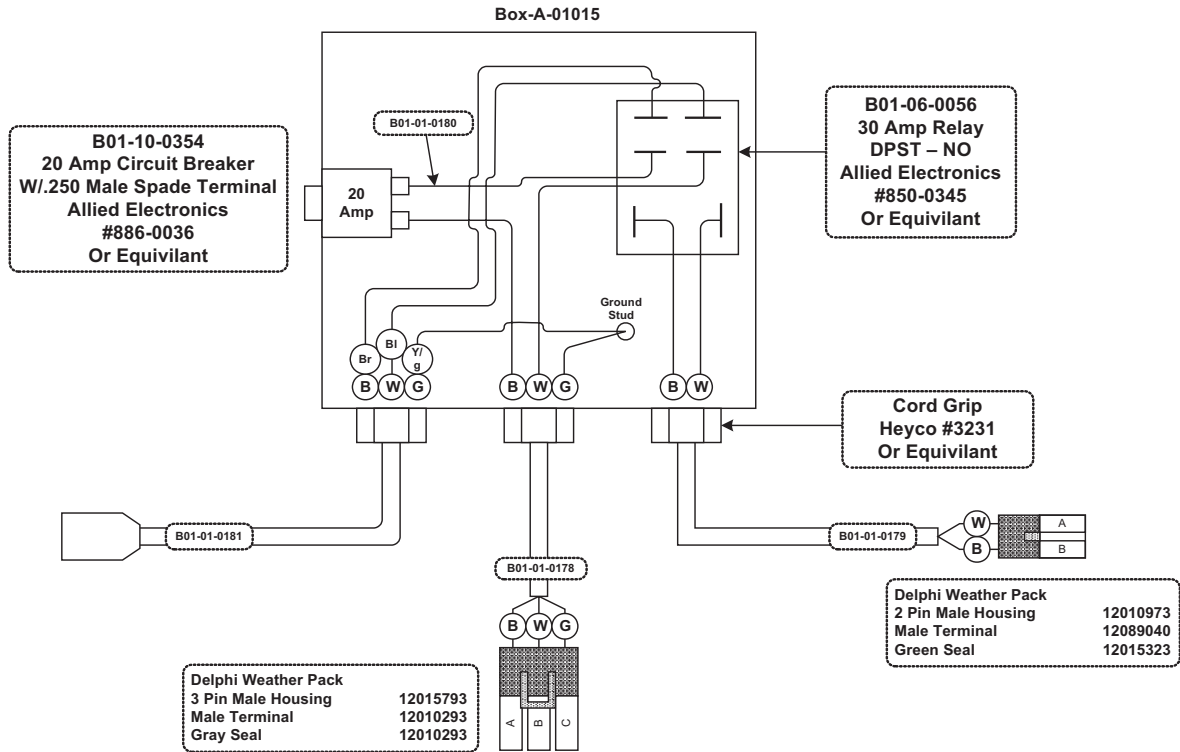

WIRE ASSEMBLY – FAN (A-03041)

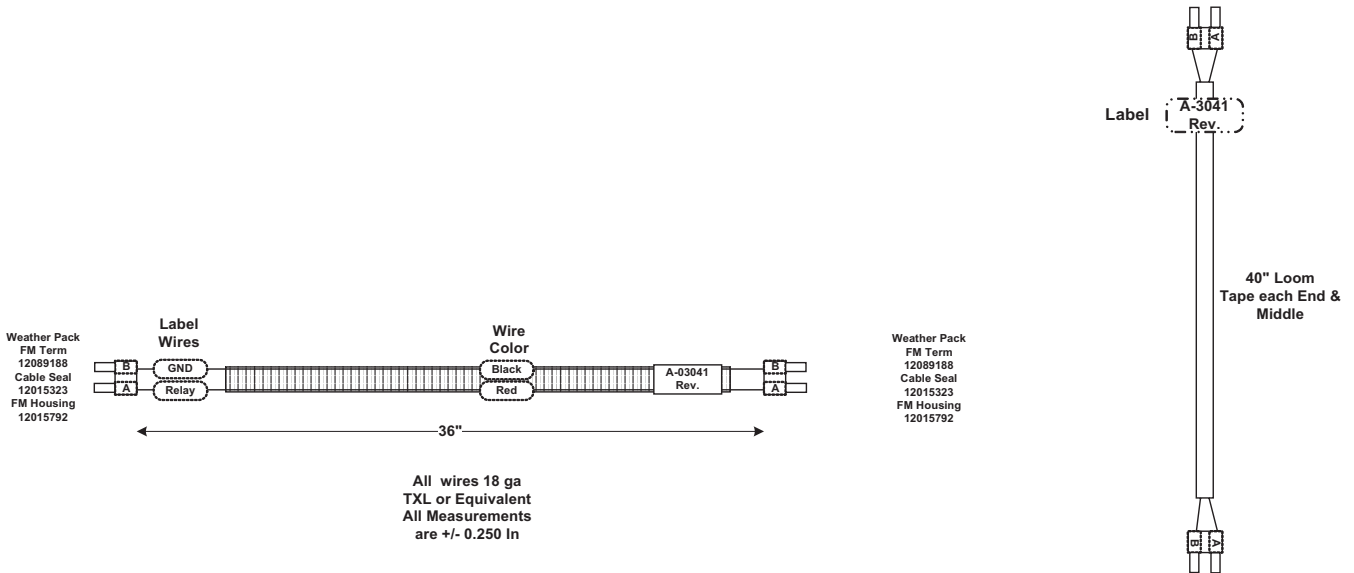

IEC CORD MALE – US MARKETS (A-03042)

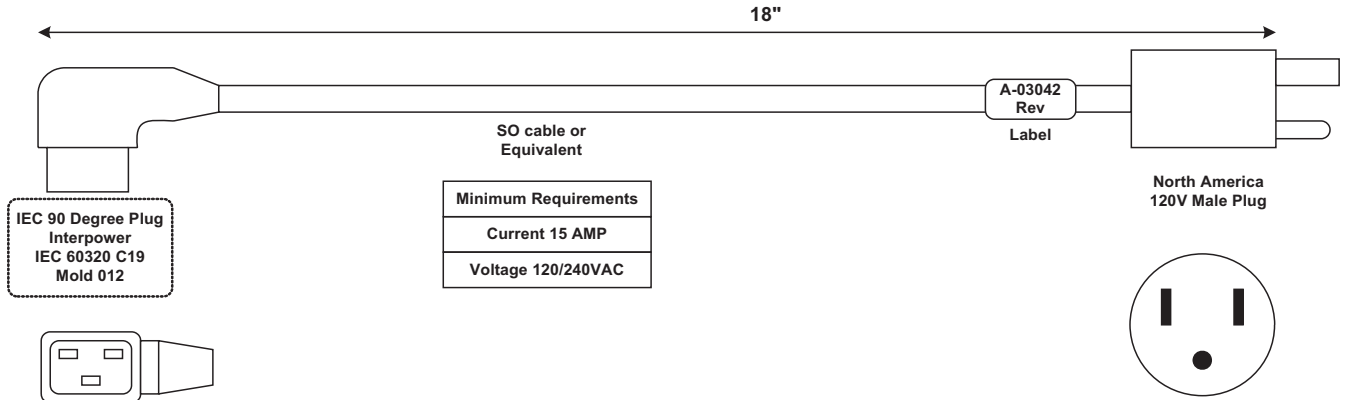

GENERATOR 110V WIRE HARNESS (A-03043)

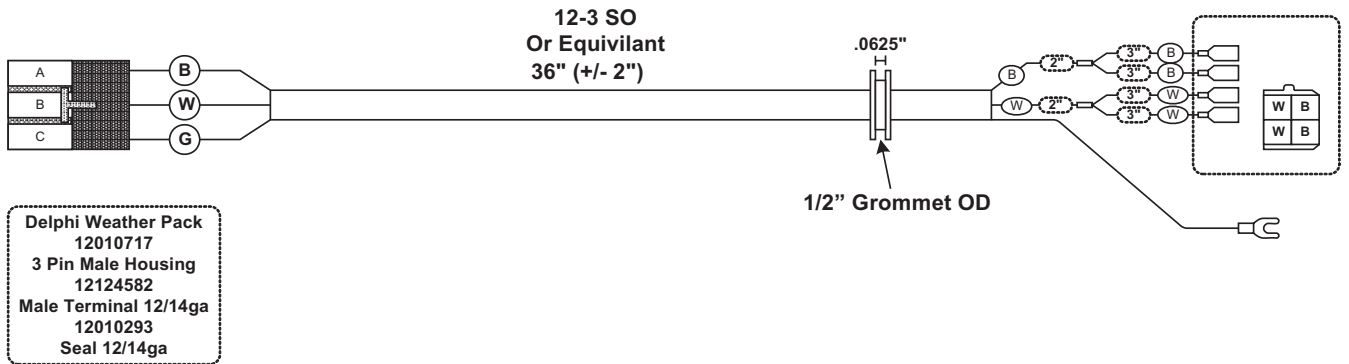

OIL SWITCH ASSEMBLY (A-03044A)

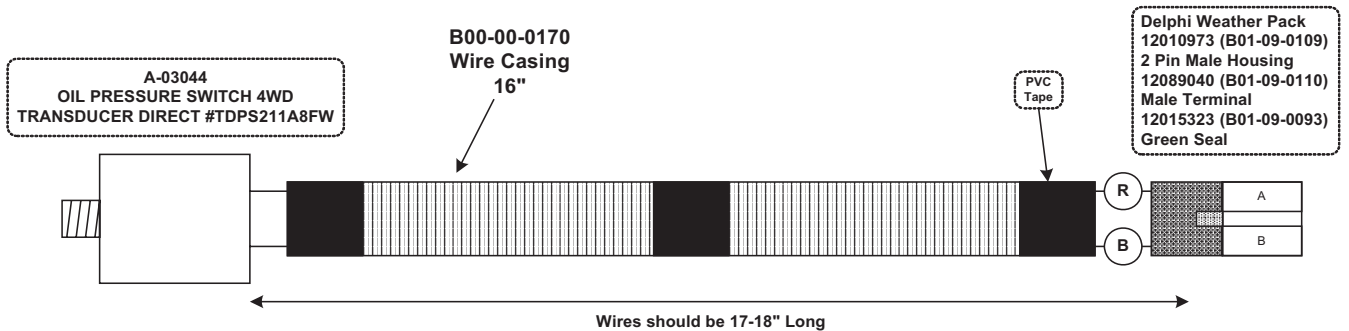

CORD ASSEMBLY 110V GENERATOR (B01-01-0178)

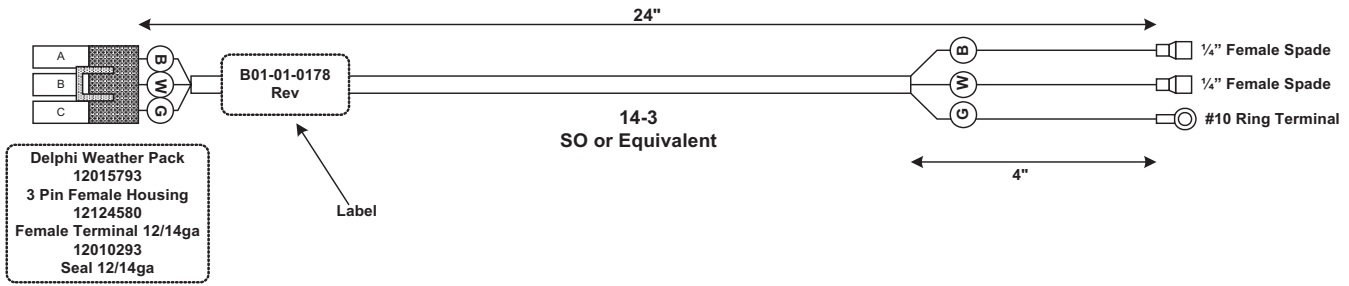

CORD ASSEMBLY GENERATOR SWITCH (B01-01-0179)

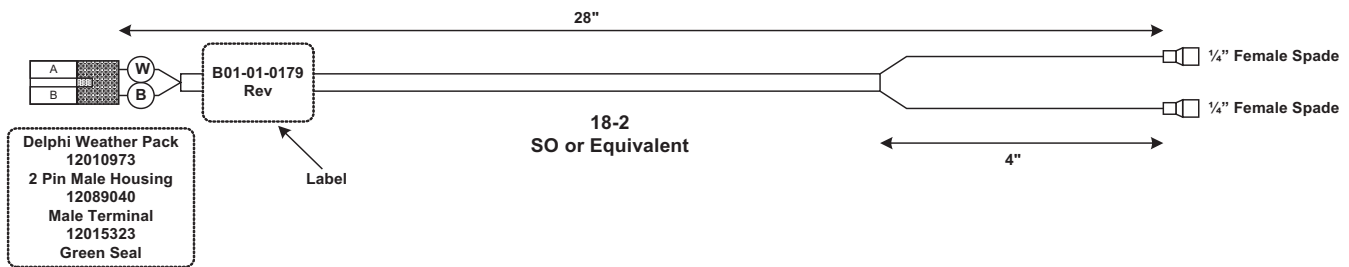

CORD ASSEMBLY SWITCH JUMPER (B01-01-0180)

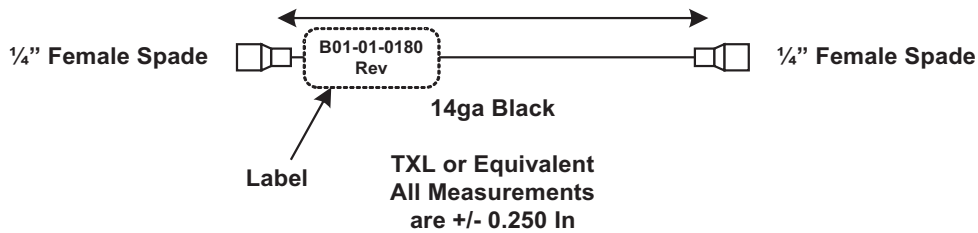

CORD ASSEMBLY 110V AC PLUG – FM (B01-01-0181)

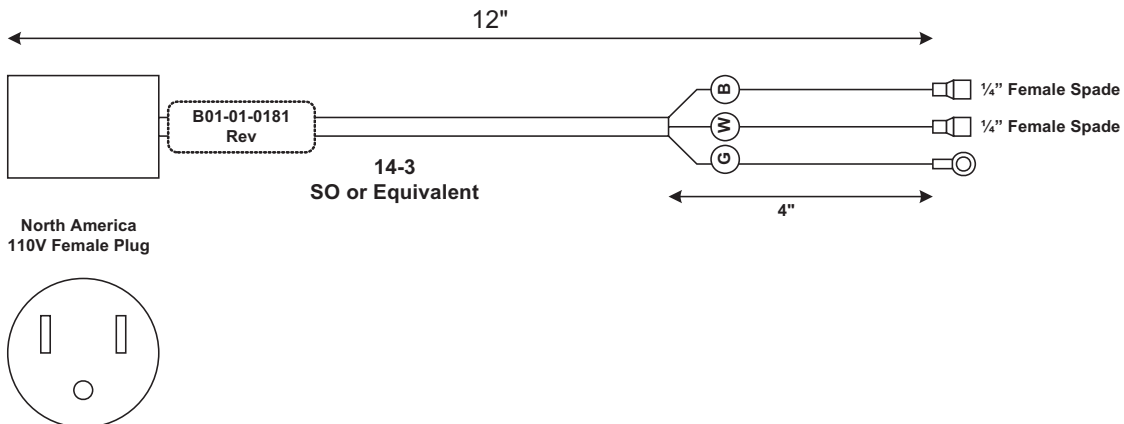

SWITCHER BOX ASSEMBLY – CE MODELS (A-03040CE)

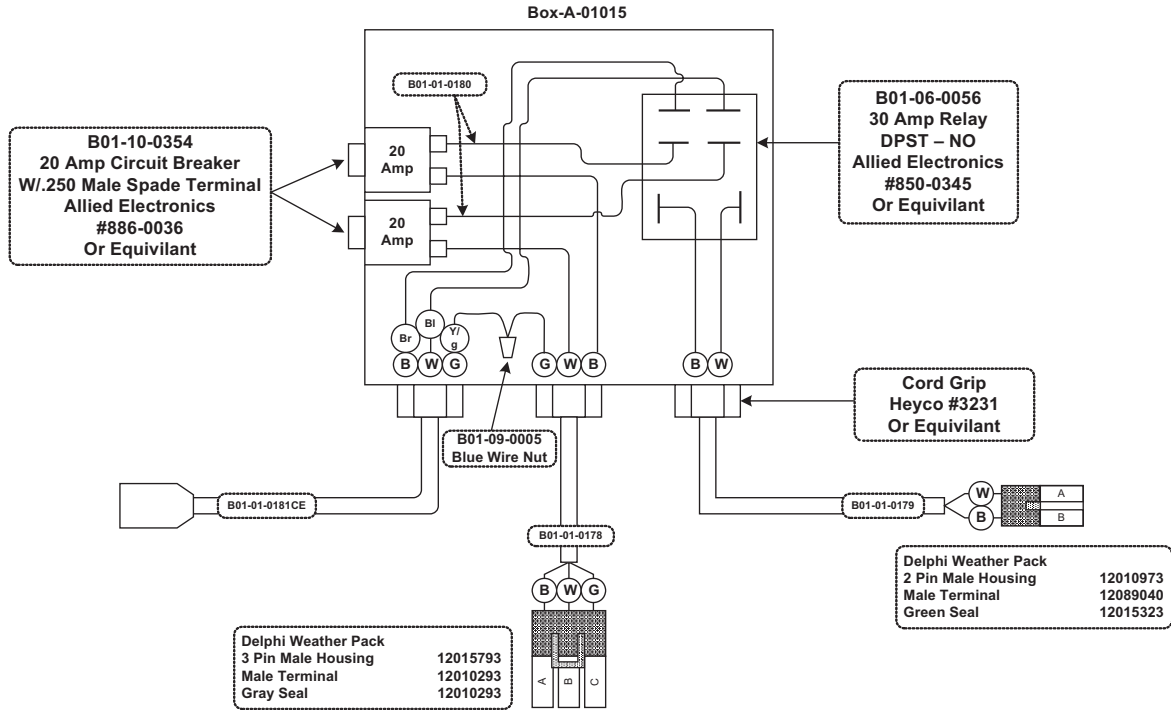

220V GENERATOR WIRE HARNESS – CE (A-03043CE)

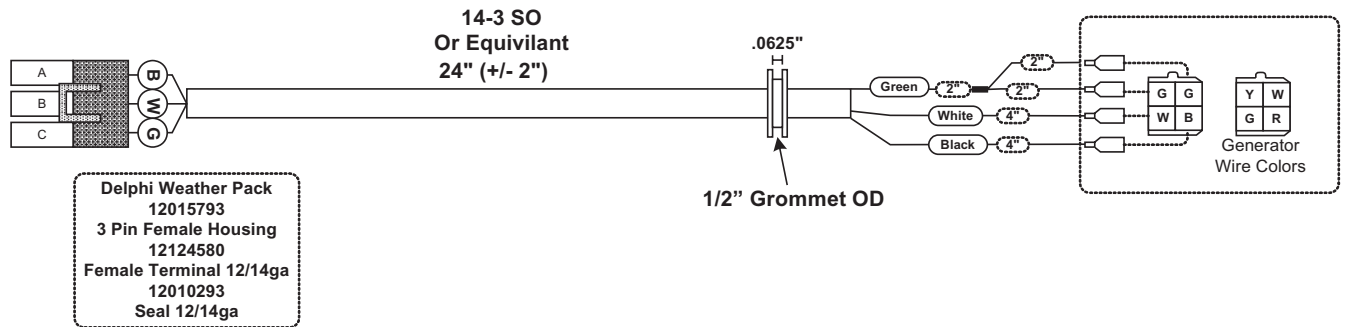

CORD ASSEMBLY 220V AC PLUG – CE (B01-01-0181)

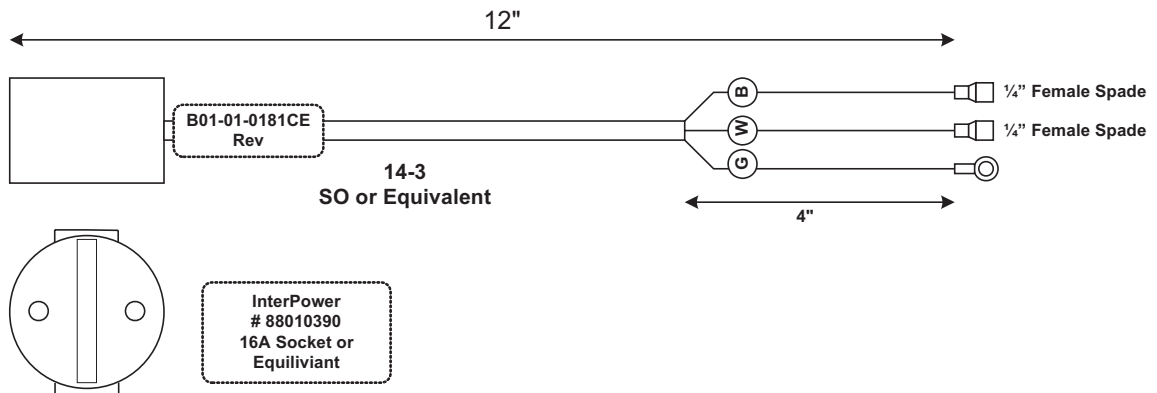

PLATFORM-GROUND COMMUNICATION CABLE (A-00714)

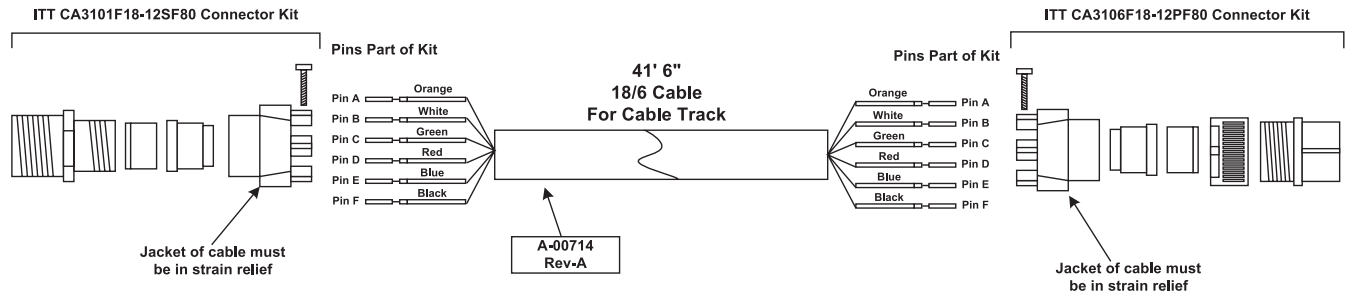

MATERIAL LIFT HOOK ASSEMBLY (OPTION A-00846)

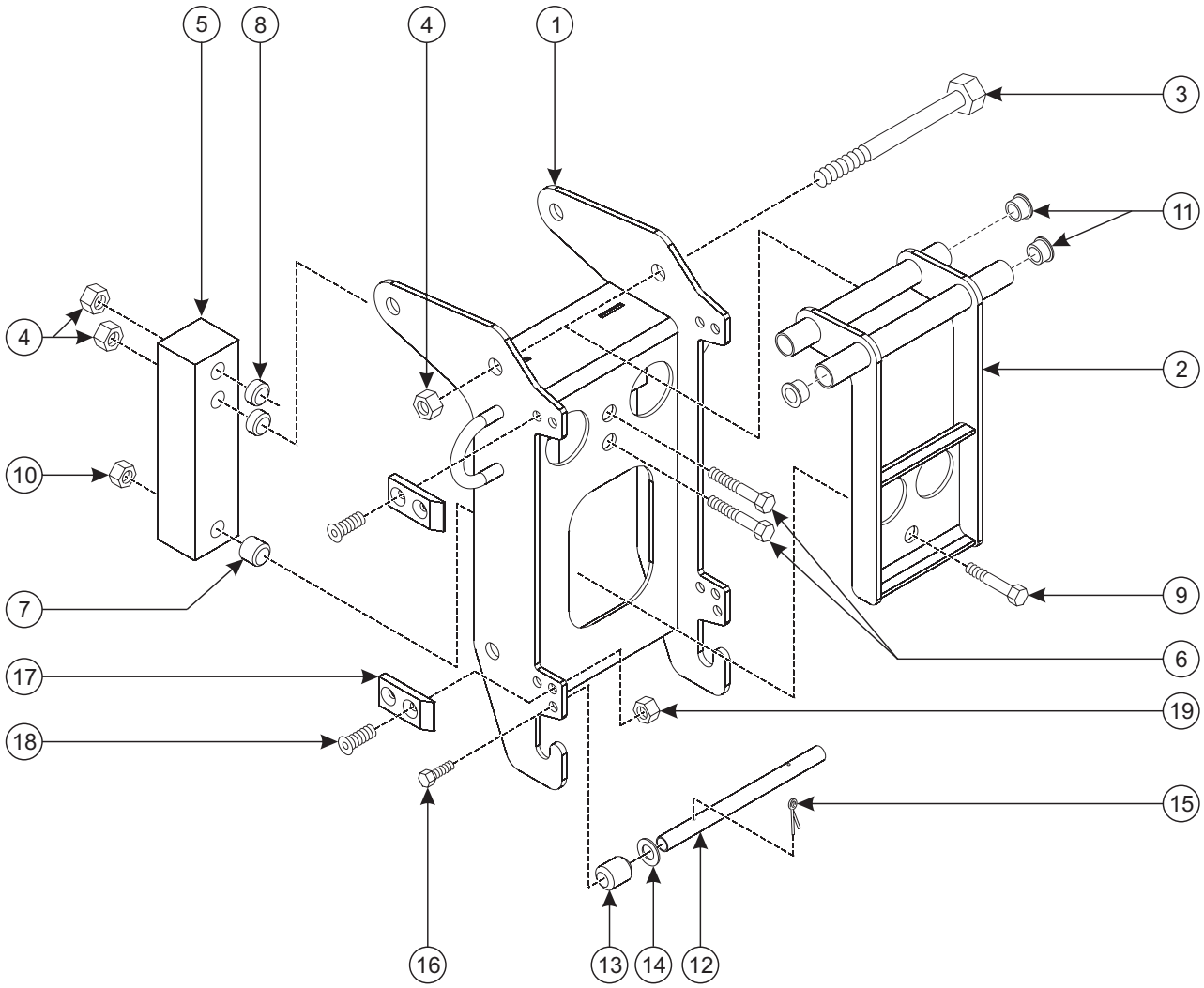

MATERIAL LIFT HOOK PARTS LIST

Item No.	Part No.	Description	Qty.
1	A-00977	Platform Mount Weldment – LS	1
2	A-00982	Load Sense Weldment	1
3	0096-0055	Cap Screw, M12 x 190	1
4	0096-0042	Hex Nut, Self-Locking, M12	3
5	A-00988-1	Load Cell	1
6	0096-0089	Cap Screw, M12 x 65	2
7	A-00990A	Load Sense Spacer A	1
8	A-00990B	Load Sense Spacer B	2
9	0096-0069	Cap Screw, M10 x 75	1
10	0096-0041	Hex Nut, Self-Locking, M10	1
11	A-00033	Bearing	4
12	A-00994	LS Roller Bar	1
13	A-00995	LS Roller	2
14	0096-0046	Washer, Flat, M12	2
15	0090-0147	Cotter Pin	2
16	0096-0009	Cap Screw, M8 x 10	2
17	A-00038	Ramp	4
18	0096-0003	Flat Head Cap Screw, M6 x 20	8
19	0096-0039	Hex Nut, Self-Locking, M6	8

20	A-00992	Load Sense Interface (Not Pictured)	1
21	0096-0085	Cap Screw, M6 x 60	3
22	0096-0039	Hex Nut, Self-Locking, M6	3

BATTERY LAYOUT

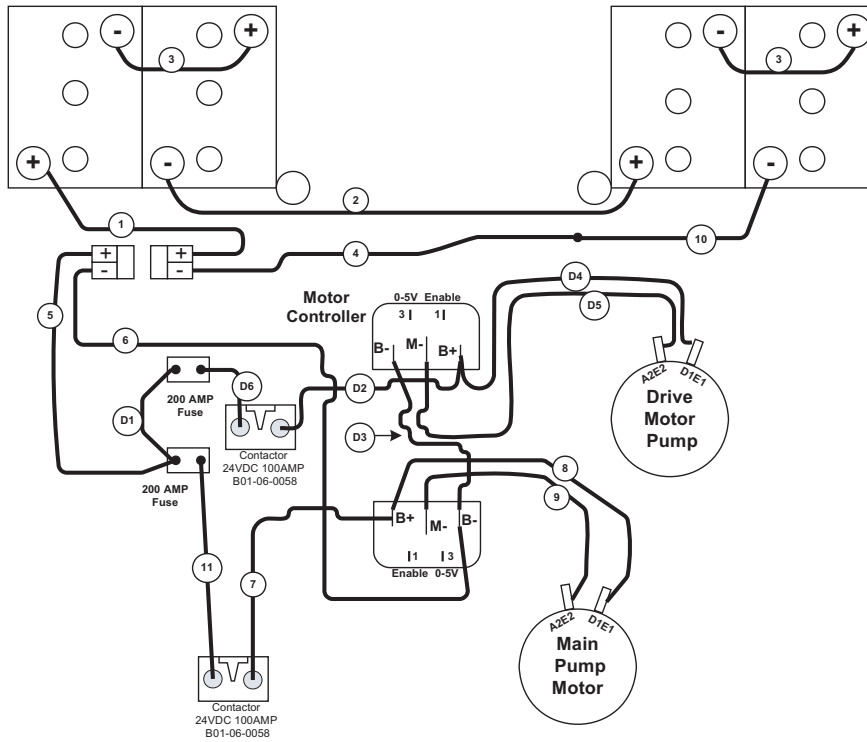

Item No.	Kit No. A-00272
1	30" Red, 2 Gauge, 5/16 Ring – Lug
2	45" Black, 2 Gauge, 5/16 Ring – 5/16 Ring
3	8" Black, 2 Gauge, 5/16 Ring – 5/16 Ring
4	22" Black, 2 Gauge, 5/16 Ring – Lug
5	24" Red, 2 Gauge, 5/16 Ring – Lug
6	48" Black, 2 Gauge, 5/16 Ring – Lug
7	22" Red, 2 Gauge, 5/16 Ring – Lug
8	48" Red, 2 Gauge, 5/16 Ring – 5/16 Ring
9	45" Black, 2 Gauge, 5/16 Ring – 5/16 Ring
10	19" Black, 2 Gauge, 5/16 Ring – 5/16 Ring
11	13" Red, 2 Gauge, 5/16 Ring – 5/16 Ring
Item No.	Kit No. A-00934
D1	6" Red, 2 Gauge, 5/16 Ring – 5/16 Ring
D2	30" Red, 2 Gauge, 5/16 Ring – 5/16 Ring
D3	13" Black, 2 Gauge, 5/16 Ring – 5/16 Ring
D4	40" Red, 2 Gauge, 5/16 Ring – 5/16 Ring
D5	40" Black, 2 Gauge, 5/16 Ring – 5/16 Ring
D6	20" Red, 2 Gauge, 5/16 Ring – 5/16 Ring



125 Taylor Parkway
Archbold, OH 43502
Phone (419) 445-8915
(800) 537-0540
Fax (419) 445-0367

<http://www.biljax.com>

Distributed by:

--