

Doc Title :	Product Data – User’s Guide	Revision :	R.00
Model :	L401 series & L301 series	Page(s) :	1 of 38

USER MANUAL

L301 / L302 / L303 / L304 / L305

L401 / L402 / L403 / L404 / L405

**Digital Cordless Phone
With Answering Machine for L401 Series**

Warning

*Use only rechargeable battery pack.
Charge the handset for 24 hours before use.*

Doc Title :	Product Data – User’s Guide	Revision :	R.00
Model :	L401 series & L301 series	Page(s) :	2 of 38

Welcome...

to your new Motorola Digital Cordless Phone!

Please retain your original dated sales receipt for your records. For warranty service of your Motorola product, you will need to provide a copy of your dated sales receipt to confirm warranty status. Registration is not required for warranty coverage.

For product related questions, please call:

<INSERT NUMBER> in the USA or <INSERT NUMBER> TTY (Text Telephone)

On the Web: www.motorola.com/

- 30 Name and number phonebook.
- Answering machine with 15 minutes digital recording time. (For L401 series only)
- Caller ID shows you who’s calling and see details of the last 30 callers in a calls list.*
- Register up to 5 handsets to a single base.
- Make internal calls, transfer external calls, hold 3-way conversation between two internal callers and an external caller.

* You must subscribe to your network provider’s Caller ID or Call Waiting service for these features to work. Please note that this equipment is not designed for making emergency telephone calls when the power fails. Alternative arrangements should be made for access to emergency. Alternatively, you may find the answer in the ‘Help’ section at the back of this user’s guide.

Doc Title :	Product Data – User’s Guide	Revision :	R.00
Model :	L401 series & L301 series	Page(s) :	3 of 38

This User’s Guide provides you with all the information you need to get the most from your phone.

Before you make your first call you will need to set up your phone.

Follow the simple instructions in ‘Getting Started’, on the next few pages.

IMPORTANT

Only use the telephone line cord supplied.

This equipment is not designed for making emergency telephone calls when the power fails. Alternative arrangements should be made for access to emergency services.

Got everything?

- Handset
- Base
- Quick start guide
- Battery door
- AAA NiMH rechargeable battery pack
- Power adapter for the base
- Telephone line cord

In multihandset packs, you will find one or more additional handsets, chargers with power supply units, additional rechargeable battery packs and battery doors.

Table of Contents

1	<u>GETTING STARTED</u>	6
2	<u>GETTING TO KNOW YOUR PHONE</u>	8
3	<u>USING THE PHONE</u>	17
3.1	CALLS	17
3.1.1	MAKE A CALL	17
3.1.2	PREDIAL	17
3.1.3	DIAL ONE TOUCH NUMBERS 1 TO 9	17
3.1.4	CALL FROM THE PHONEBOOK	17
3.1.5	CALL FROM THE CALLS LIST	17
3.1.6	ANSWER A CALL	17
3.1.7	ADJUST VOLUME	17
3.1.8	MUTE	17
3.1.9	END A CALL	18
3.2	INTERCOM	18
3.2.1	CALL ANOTHER HANDSET	18
3.2.2	TRANSFER AN EXTERNAL CALL TO ANOTHER HANDSET	18
3.2.3	THREE-PARTY CONFERENCE CALL	18
3.3	VOICEMAIL	18
3.3.1	CLEAR VOICE MAIL	18
4	<u>PHONEBOOK</u>	19
4.1	VIEW AN ENTRY	19
4.2	ADD AN ENTRY	19
4.3	EDIT AN ENTRY	19
4.4	DELETE AN ENTRY	20
4.5	DELETE ALL ENTRIES	20
4.6	VIEW PHONEBOOK CAPACITY	20
4.7	STORE A PHONEBOOK ENTRY AS A ONE TOUCH NUMBER	20
4.8	EDIT A PHONEBOOK ENTRY IN A ONE TOUCH NUMBER	20
4.9	DELETE A ONE TOUCH NUMBER	20
5	<u>CALLER ID</u>	21
5.1	CALLS LIST	21
5.1.1	VIEW THE CALLS LIST	21
5.1.2	SAVE A NUMBER FROM THE CALLS LIST TO THE PHONEBOOK	21
5.1.3	DELETE A CALLS LIST ENTRY	21
5.1.4	DELETE ENTIRE CALLS LIST	21
5.2	REDIAL	22
5.2.1	VIEW THE REDIAL LIST	22
5.2.2	COPY A REDIAL NUMBER TO THE PHONEBOOK	22
5.2.3	DELETE A REDIAL LIST ENTRY	22
5.2.4	DELETE ENTIRE REDIAL LIST	22
6	<u>PERSONAL SETTINGS</u>	23
6.1	SET DATE & TIME	23

Doc Title :	Product Data – User’s Guide	Revision :	R.00
Model :	L401 series & L301 series	Page(s) :	5 of 38

6.2	HANDSET TONES	23
6.2.1	SET THE RINGER TONE.....	23
6.2.2	SET THE RINGER VOLUME.....	23
6.2.3	KEY TONES ON/OFF.....	23
6.2.4	BATTERY LOW TONE ON/OFF.....	23
6.2.5	NO COVERAGE TONE ON/OFF.....	23
6.3	HANDSET NAME	23
6.4	SET THE DISPLAY LANGUAGE	24
6.5	SET THE LCD CONTRAST	24
6.6	AUTO TALK ON/OFF	24
7	<u>ADVANCED SETTINGS</u>	25
7.1	SET THE DIAL MODE	25
7.2	SET THE FLASH TIME	25
7.3	SET THE AREA CODE	25
7.4	REGISTRATION	25
7.4.1	REGISTER A HANDSET.....	25
7.4.2	DE-REGISTER ALL HANDSETS.....	25
7.5	RESET ALL SETTINGS	25
8	<u>USING YOUR ANSWERING MACHINE (FOR L401 SERIES ONLY)</u>	26
8.1	PLAY MESSAGES	26
8.2	DELETE ALL MESSAGES	26
8.3	ANNOUNCEMENT	26
8.3.1	RECORD THE ANNOUNCEMENT.....	26
8.3.2	PLAY THE ANNOUNCEMENT.....	26
8.4	ANSWERING MACHINE SETTINGS	27
8.4.1	SET THE ANSWER MODE.....	27
8.4.2	MESSAGE ALERT ON/OFF.....	27
8.4.3	SET THE NUMBER OF RINGS.....	27
8.4.4	RECORD A MEMO.....	27
8.4.5	CALL SCREENING ON/OFF.....	27
8.4.6	REMOTE ACCESS ON/OFF.....	27
8.4.7	SET THE SECURITY CODE.....	28
9	<u>DEFAULT SETTINGS</u>	29
10	<u>HELP</u>	30
11	<u>GENERAL INFORMATION</u>	32

Doc Title :	Product Data – User’s Guide	Revision :	R.00
Model :	L401 series & L301 series	Page(s) :	6 of 38

1 GETTING STARTED

WARNING

Do not place your phone in the bathroom or other humid areas.

Location

When choosing a location for your new phone, here are some important guidelines you should consider:

- Avoid sources of noise and heat, such as motors, fluorescent lighting, microwave ovens, heating appliances and direct sunlight.
- Avoid areas of excessive dust, moisture and low temperature.
- Avoid other cordless telephones or personal computers.
- Never install telephone wiring during a lightning storm.
- Never install telephone jacks in wet locations unless the jack is specifically designed for wet locations.
- Never touch non-insulated telephone wires or terminals, unless the telephone line has been disconnected at the network interface.
- Use caution when installing or modifying telephone lines.

HANDSET RANGE

Optional range is reached when there are no other electrical appliances working within the range area. Any obstruction between the base and handset will also reduce the significantly.

SIGNAL STRENGTH

*When out of range of the base, the screen shows **SEARCHING....** If you are on a call, the line will hang up. Move back within in range. The handset will automatically re-connect to the base.*

Setting up

IMPORTANT

The base station must be plugged into the power outlet at all times. Do not connect the telephone line cord into the wall socket until the handset is fully charged. Only use the power and telephone line cords supplied with the product.

WHICH POWER ADAPTER

The power adapter with the smaller pin is for the base unit and the power adapter with the bigger pin is for the charger unit.

Connecting the base station

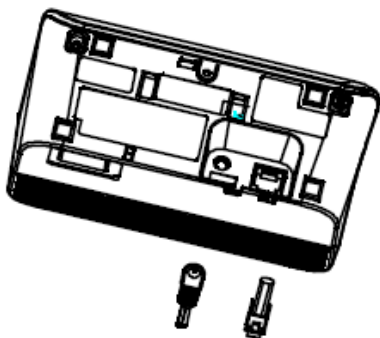

1. Plug the power adapter & telephone line cord into the base station.
2. Plug the other end of the power adapter & telephone line cord into the wall jack.
3. Always use the telephone line cord provided in the box.
4. Use only the provided adapter.

Doc Title :	Product Data – User’s Guide	Revision :	R.00
Model :	L401 series & L301 series	Page(s) :	7 of 38

Install and charge the handset battery pack

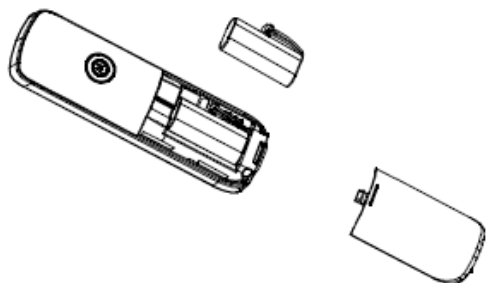

1. Slide out the battery compartment cover.
2. Place the supplied rechargeable battery pack in the battery compartment.
3. Slide the battery compartment cover back.
4. Put the handset on the base to charge for at least 24 hours. When the handset is fully charged the <Battery icon> will indicate that it is fully charged.
5. Use only the rechargeable battery pack provided.

BATTERY LOW WARNING

If the <Battery icon> flashes in the display, you will need to recharge the handset before you can use it again. During charging, the <Battery icon> will scroll in the display.

BATTERY PERFORMANCE

In ideal conditions, fully charged battery pack should give about 12 hours talk time or 180 hours standby time on a single charge.

Note that new battery packs do not reach full capacity until they have been in normal use for several days.

To keep your battery packs in the best condition, leave the handset off the base for a few hours at a time.

Running the battery packs right down at least once a week will help them last as long as possible.

The charge capacity of rechargeable battery packs will reduce with time as they wear out, giving the handset less talk/standby time. Eventually they will need to be replaced.

After charging your handset for the first time, subsequent charging time is about 6–8 hours a day. The battery pack and handset may become warm during charging. This is normal.

2 GETTING TO KNOW YOUR PHONE

Overview of your handset (for L401 series)

1	Menu/ Select In idle mode: press to access menu list. In menu/editing mode: press to confirm and save the settings. During a call: press to hold a call. In calls list entry: press to save the entry to the phonebook. In phonebook entry: press to go to phonebook editing mode.
2	Scroll up/ Volume up In menu mode: press to scroll up. In editing mode: press to move cursor to the left. During a call: press to increase volume. Calls list/phonebook/redial list entry: press to scroll up the list. In answering machine mode: press to increase volume.
3	Right/ Calls list In idle mode/during a call: press to access calls list. In editing mode: press to move the cursor to the right.
4	Scroll down/ Volume down/ Redial list In idle mode: press to access redial list. In menu mode: press to scroll down. In editing mode: press to move cursor to the right. During a call: press to decrease volume. Calls list/phonebook/redial list entry: press to scroll down the list. In answering machine mode: press to decrease volume.
5	Talk off/ Back In menu/editing mode/phonebook entry: press to exit to previous level. In pre-dial mode/calls list/redial list entry/ answering machine mode: press to exit to idle. During a call: press to end a call.
6	Alphanumeric keypad In idle/pre-dial/editing mode/during a call: press to enter characters/numbers. Long press to activate speed dial.
7	#/ Pause/ ABC/ Format In idle/pre-dial/during a call mode: press to insert a “#”. In number editing mode: press to insert a “#”, press twice to insert a pause. In name editing mode: toggle ABC/Abc/abc. In calls list entry: press to toggle CID display format among 7, 8, 10 and 11 digits.
8	Intercom In idle mode/during a call: press to initiate an intercom call.
9	Microphone
10	Speaker In idle/menu/pre-dial mode/during a call: press to turn on/off the speakerphone. Call List/phonebook/redial list entry: press to make a call with speakerphone. During ringing: press to answer a call with speakerphone. In answering machine mode: press to toggle the message playback via earpiece/speakerphone

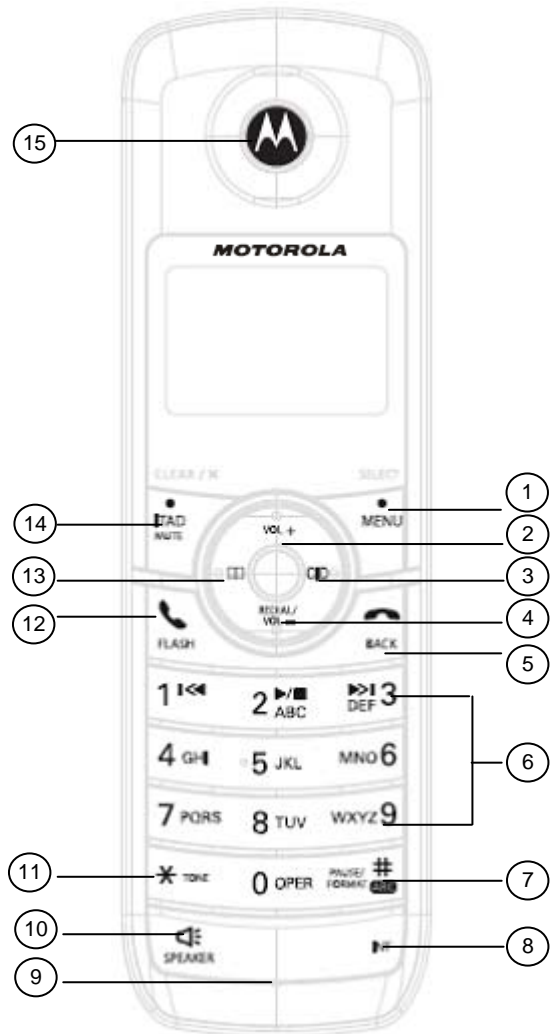

Doc Title :	Product Data – User’s Guide	Revision :	R.00
Model :	L401 series & L301 series	Page(s) :	9 of 38

11	<p>*/ Tone</p> <p>In idle/pre-dial/editing mode: press to insert a “*”.</p> <p>During a call: press to switch from pulse to tone dialing temporarily li pulse mode is selected before. After the call is ended, the dial mode will resume to pulse.</p>
12	<p>Talk on/ Flash</p> <p>In idle/menu/pre-dial mode: press to make a call.</p> <p>Call List/phonebook/redial list entry: press to make a call to the selected entry</p> <p>During a call: press to make a flash.</p> <p>During ringing: press to answer a call.</p>
13	<p>Left/ Phonebook</p> <p>In idle mode/during a call: press to access the phonebook.</p> <p>In editing mode: press to move the cursor to the left.</p>
14	<p>Mute/ Clear/ Delete/ Answering Machine main menu</p> <p>In idle mode: press to play the voice prompt of answering machine main menu.</p> <p>In pre-dial/editing mode: press to delete one character/digit. Long press to delete all characters/digits.</p> <p>During a call: press to mute/unmute the call.</p> <p>In calls list/phonebook entry: press to delete the entry.</p> <p>In answering machine mode: press to delete the current message playback.</p>
15	<p>Earpiece</p>

Overview of your handset (for L301 series)

1	<p>Menu/ Select In idle mode: press to access menu list. In menu/editing mode: press to confirm and save the settings. During a call: press to hold a call. In calls list entry: press to save the entry to the phonebook. In phonebook entry: press to go to phonebook editing mode.</p>
2	<p>Scroll up/ Volume up In menu mode: press to scroll up. In editing mode: press to move cursor to the left. During a call, press to increase volume. Calls list/phonebook/redial list entry: press to scroll up the list.</p>
3	<p>Right/ Calls list In idle mode/during a call: press to access calls list. In editing mode: press to move the cursor to the right.</p>
4	<p>Scroll down/ Volume down/ Redial list In idle mode: press to access redial list. In menu mode: press to scroll down. In editing mode: press to move cursor to the right. During a call, press to decrease volume. Calls list/phonebook/redial list entry: press to scroll down the list.</p>
5	<p>Talk off/ Back In menu/editing mode/phonebook entry: press to exit to previous level. In pre-dial mode/calls list/redial list entry: press to exit to idle. During a call: press to end a call.</p>
6	<p>Alphanumeric keypad In idle/pre-dial/editing mode/during a call: press to enter characters/numbers. Long press to activate speed dial.</p>
7	<p>#/ Pause/ ABC/ Format In idle/pre-dial/during a call mode: press to insert a “#”. In number editing mode: press to insert a “#”, press twice to insert a pause. In name editing mode: toggle ABC/Abc/abc. In calls list entry: press to toggle CID display format among 7, 8, 10 and 11 digits.</p>
8	<p>Intercom In idle mode/during a call: press to initiate an intercom call.</p>
9	<p>Microphone</p>
10	<p>Speaker In idle/menu/pre-dial mode/during a call: press to turn on/off the speakerphone. Call List/phonebook/redial list entry: press to make a call with speakerphone. During ringing: press to answer a call with speakerphone.</p>

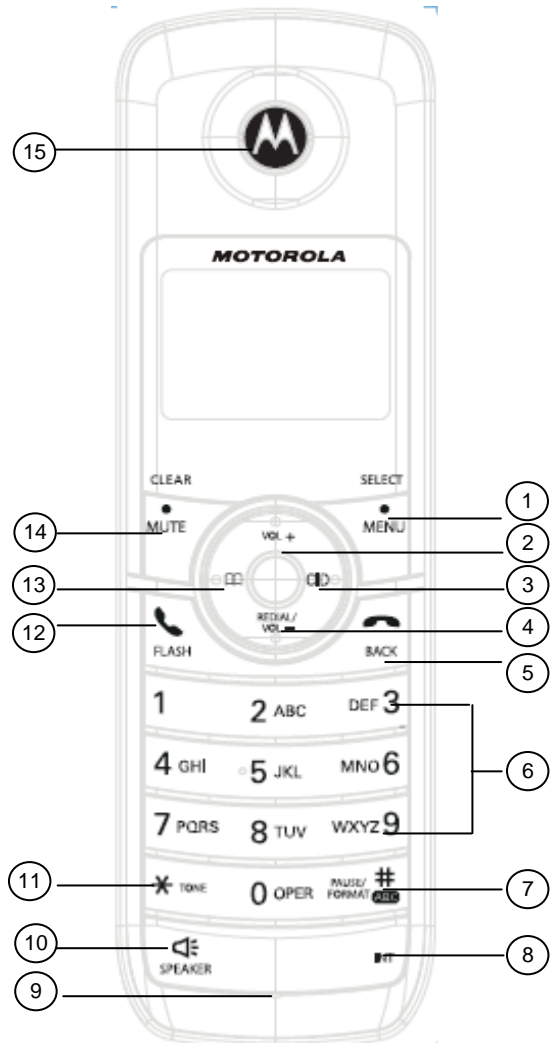

Doc Title :	Product Data – User’s Guide	Revision :	R.00
Model :	L401 series & L301 series	Page(s) :	11 of 38

11	<p>*/ Tone</p> <p>In idle/pre-dial/editing mode: press to insert a “*”.</p> <p>During a call: press to switch from pulse to tone dialing temporarily li pulse mode is selected before. After the call is ended, the dial mode will resume to pulse.</p>
12	<p>Talk on/ Flash</p> <p>In idle/menu/pre-dial mode: press to make a call.</p> <p>Call List/phonebook/redial list entry: press to make a call to the selected entry.</p> <p>During a call: press to make a flash.</p> <p>During ringing: press to answer a call.</p>
13	<p>Left/ Phonebook</p> <p>In idle mode/during a call: press to access the phonebook.</p> <p>In editing mode: press to move the cursor to the left.</p>
14	<p>Mute/ Clear/ Delete</p> <p>In pre-dial/editing mode: press to delete one character/digit.</p> <p>Long press to delete all characters/digits.</p> <p>During a call: press to mute/unmute the call.</p> <p>In calls list/phonebook entry: press to delete the entry.</p>
15	<p>Earpiece</p>

Handset display

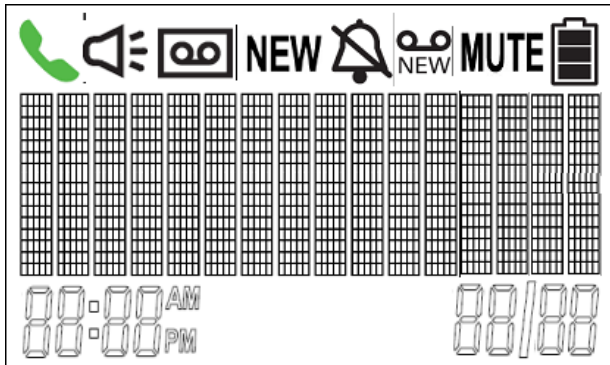

	On when the line is in use. Flashes when there is an incoming call.
	On when speakerphone is turned on.
	On when answering machine is turned on. Flashes when new answering machine message is received. (for L401 series only)
NEW	Indicates when new call is received. Off when new call has been viewed.
	On when ringer volume is turned off.
	On when there is received new voice mail not yet listened to. Off when new voice mail has been listened to.
MUTE	On when a call is muted.
	Full battery power level.
	2/3 battery power level.
	1/3 battery power level.
	Flashes when low battery level is detected, needs charging.
	Animation in cycle. Battery is charging.

Overview of the base (for L401 series)

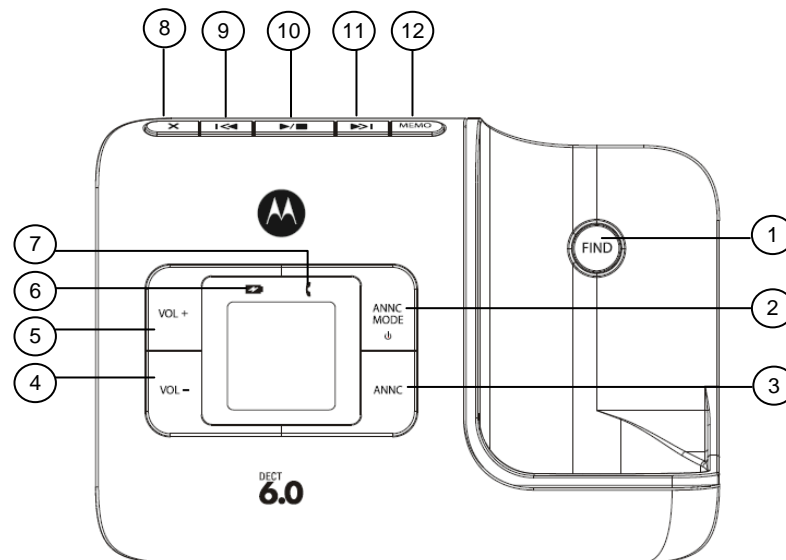

1	FIND Press to find/page all registered handsets.
2	ANSWER ON/OFF/ ANSWER MODE Press to toggle answering machine mode among ANSWER OFF, ANNC & RECORD and ANNOUNCE ONLY mode.
3	ANNOUNCE In Idle: Short press to play the current announcement. In Idle: Press and hold to listen a voice prompt of how to record the personalized announcement of the current answer mode, release key to stop recording.
4	VOLUME - Decrease the loudspeaker volume by one level (1 to 8) during message playback. In Idle or during call screening: Base speaker volume levels 0 to 8 are available.
5	VOLUME + Increase the loudspeaker volume by one level (1 to 8) volume during message playback. In Idle or during call screening: Base speaker volume levels 0 to 8 are available.
6	Charging LED – Green Steadily ON: When the handset is put into base cradle for charging.
7	In Use LED – Red Steadily ON: During a call or when an extension phone (a parallel set) or the built-in answering machine is off hook. Flashing at a cadence according to the incoming ring pattern: During an incoming call Flash at a rate of 0.5s on and 0.5s off for 2 minutes: During paging or registration.
8	DELETE During message playback: Delete the current message. In Idle: Press and hold to erase all read messages (applicable only when messages in answering machine are all read, new message(s) will not be deleted.)
9	SKIP BACKWARD Press once to replay current message from the beginning. Press twice to playback the previous message.
10	PLAY/ STOP In message playback mode: Press to playback or stop playing messages.
11	SKIP FORWARD Skip to play the next message.
12	MEMO In Idle: Press and hold to listen a voice prompt recording a memo and start to record a memo. Release key to stop recording memo.

Doc Title :	Product Data – User’s Guide	Revision :	R.00
Model :	L401 series & L301 series	Page(s) :	14 of 38

2-digit 7-seg LCD display	Behavior
--	When answering machine is OFF.
00	Steadily ON: No voice messages in answering machine
09	Flash in idle: Indicate the number of answering machine messages and there is an unread message. (E.g. there are 9 answering machine messages in total. Total number of messages is from 1 to 59.) Flash during message playing: Playing the selected answering machine message. Steadily On: If all the new messages have been read and there are 9 answering machine messages in total.
f	Flashing: answering machine memory is full.
CL	Flashing - -: Time is not set and there are old voice messages kept in the answering machine memory only (no new voice messages).
≡≡/09	Blinking between ≡≡/09: When recording personalized announcement or recording a memo. The numbers (e.g. 09) indicate the total number of messages in answering machine when playing announcement.
In	Flashing: Indicates an incoming call / recording of an incoming call.
An	Steadily ON: Represent Announce Only mode.
LA	Flashing: Line Remote access is in progress.
LA/09	Blinking between LA/09: When remote access is in progress and the numbers (e.g. 09) indicate the total number of messages.
L3	Steadily ON: Indicate the base speaker volume level is 3. (eight volume levels from L1 to L8 are provided) L3 disappears after 3 seconds.

Paging is a useful way of finding lost handsets.

1. Press <FIND> on the base.

- All handsets ring.

2. To stop the paging call, press <FIND> again, or place the handset on the cradle or press any key on the handset.

Overview of the base (for L301 series)

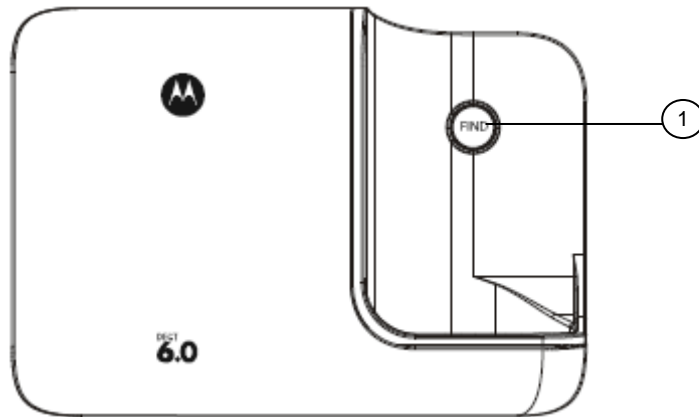

1	FIND Press to find/page all registered handsets.
----------	--

Paging is a useful way of finding lost handsets.

1. Press <FIND> on the base.

- All handsets ring.

2. To stop the paging call, press <FIND> again, or place the handset on the cradle or press any key on the handset.

Navigating the menus

1. Press <Menu>.

2. Press <Up/Down> to scroll through the menu.

3. Press <Menu> to open a sub-menu or validate an option.

Press <Talk off/Back> to go back to previous menu level or cancel an action.

If you do not press any button on the handset for 30 seconds the display will automatically return to standby. It will also return to standby when the handset is placed on the base or charger.

Menu map

Main Menu	DATE & TIME	PHONEBOOK	SETUP HS	SETUP BS	ANSWER MACHINE (for L401 series only)	RESET SETTINGS
Sub menu	YEAR DATE	VIEW ADD EDIT DELETE DELETE ALL PB CAPACITY SPEED DIAL	RINGER TONE RINGER VOLUME KEY TONE LOW BATT TONE OUT RANGE TONE HANDSET NAME LANGUAGE LCD CONTRAST AUTO TALK	DIAL MODE FLASH TIME AREA CODE	ANSWER MODE MESSAGE ALERT NUMBER OF RINGS ANNOUNCEMENT RECORD MEMO CALL SCREENING REMOTE ACCESS SECURITY CODE	CLR VOICE MAIL ALL SETTINGS

Character map

Uppercase

Key	Character versus key press number								
	1	2	3	4	5	6	7	8	9
1	space	1	#	'	,	-	.	&	
2	A	B	C	2					
3	D	E	F	3					
4	G	H	I	4					
5	J	K	L	5					
6	M	N	O	6					
7	P	Q	R	S	7				
8	T	U	V	8					
9	W	X	Y	Z	9				
0	0								
*	*	?	!	/	()	@		
#									

Lowercase

Key	Character versus key press number								
	1	2	3	4	5	6	7	8	9
1	space	1	#	'	,	-	.	&	
2	a	b	c	2					
3	d	e	f	3					
4	g	h	i	4					
5	j	k	l	5					
6	m	n	o	6					
7	p	q	r	s	7				
8	t	u	v	8					
9	w	x	y	z	9				
0	0								
*	*	?	!	/	()	@		
#									

Doc Title :	Product Data – User’s Guide	Revision :	R.00
Model :	L401 series & L301 series	Page(s) :	17 of 38

3 USING THE PHONE

3.1 Calls

3.1.1 Make a call

1. Press <Talk on> or <Speaker>.
2. Dial the phone number.

3.1.2 Redial

1. Enter the phone number (maximum 32 digits). If you make a mistake, press <Clear> to delete a digit.
2. Press <Talk on> or <Speaker> to dial the phone number entered.

3.1.3 Dial one touch numbers 1 to 9

1. Press and hold a key from <1> to <9> until the number is displayed and dialed.
- *If no number is stored, you hear a beep.*

3.1.4 Call from the phonebook

1. Press <Phonebook>. *The first entry in the phonebook is displayed.*
2. Scroll <Up/Down> to the entry you want.
3. Press <Talk on> or <Speaker> to dial the number.

TIPS

Instead of scrolling to browse the phonebook entries, press the numeric key corresponding to the first letter of the entry you wish to locate. For example, pressing <2> will show the entries starting with A. Pressing <2> again will show the entries starting with B, etc.

3.1.5 Call from the calls list

NOTE

You need to subscribe to your network’s Caller ID service to be able to see the caller’s number in the calls list. See Section “5. Caller ID” for more details.

1. Press <Call log>. The first entry in the call list is displayed.
2. Scroll <Up/Down> to the entry you want.
3. Press <Talk on> or <Speaker> to dial the number.

3.1.6 Answer a call

1. When the phone rings and flashes in the display, press <Talk on> or press <Speaker> to answer the call via the loudspeaker.

WARNING

When the phone is ringing, avoid holding the earpiece too close to your ear as it may damage your hearing. Handsfree activation can suddenly increase the volume in the earpiece to a very high level. Make sure the handset is not too close to your ear.

TIPS

If Auto Talk mode (see Section 6.6 for more details) is on, simply lift up the handset from its base to answer the call. The default setting is Off.

NOTE

An incoming call has priority over other events. Whenever there is an incoming call, other operations in progress such as phone settings, menu navigation, etc. will be ended.

3.1.7 Adjust volume

1. During a call, press <Up/Down> to adjust the earpiece or loudspeaker volume.
- *The level is shown in the handset display.*

3.1.8 Mute

Mute the microphone so that you can talk to someone else in the room without your caller hearing you.

1. During a call, press <Mute/Clear>.

Doc Title :	Product Data – User’s Guide	Revision :	R.00
Model :	L401 series & L301 series	Page(s) :	18 of 38

- *The microphone is muted.*

2. Press <Mute/Clear> again to turn the microphone back on.

3.1.9 End a call

1. During a call, press <Talk off>.

After you hang up, the duration of your call is displayed for around 2 seconds.

3.2 Intercom

This feature is only available when there are at least 2 registered handsets. It allows you to make internal calls, transfer external calls from one handset to another and use the conference option.

3.2.1 Call another handset

1. Press <Intercom>.

2. Press <Up/Down> to the handset you want to call.

3. Press <Menu> to call the handset.

TIPS

You may enter the number of the handset (1 to 5) you want to call.

4. Press <Talk off> to hang up.

NOTE

If the handset does not belong to the valid range, this function may not be available.

3.2.2 Transfer an external call to another handset

1. During an external call, press <Intercom>.

- *Your caller is put on hold.*

2. Press <Up/Down> to the handset you want to call.

3. Press <Menu> to call the handset.

TIPS

You may enter the number of the handset (1 to 5) you want to call.

4. When the other handset answers by pressing <Talk on> or <Speaker>, press <Talk off> to transfer the call. If the other handset does not answer, press <Intercom> to talk to your caller again.

3.2.3 Three-party conference call

1. During an external call, press <Intercom>.

- *Your caller is put on hold.*

2. Press <Up/Down> to the handset you want to call.

3. Press <Menu> to call the handset.

TIPS

You may enter the number of the handset (1 to 5) you want to call.

4. When the other handset answers by pressing <Talk on> or <Speaker>, press <Talk on> or <Speaker> to join the conference call. If the other handset does not answer, press <Intercom> to talk to your caller again.

5. Press <Talk off> to hang up.

3.3 Voicemail

Voice Mail Waiting Indication <VMWI icon> is an indication given to you when a new voice mail message is waiting on the network service provider. This feature is available if you have subscribed to the voicemail service from your network service provider.

3.3.1 Clear voice mail

1. Press <Menu> and <Up/Down> to select RESET SETTINGS.

2. Press <Menu> to select CLR VOICE MAIL.

3. Press <Menu> to select YES

4. Press <Menu> to clear voice mail.

Doc Title :	Product Data – User’s Guide	Revision :	R.00
Model :	L401 series & L301 series	Page(s) :	19 of 38

4 PHONEBOOK

The handset phonebook can store up to 30 names and numbers.

NOTE

Numbers can be up to 24 digits long and names up to 16 characters long. Entries are stored in alphabetical order.

4.1 View an Entry

1. Press <Phonebook>.
2. Press <Up/Down> to the entry you want.
3. Press <Menu> to select VIEW.
4. Press <Menu> to view the entry.

NOTE

If the number is more than 15 digits, press <#> to view the next page of remaining digits.

4.2 Add an Entry

1. Press <Phonebook>.
2. If the list is empty, LIST EMPTY is displayed. Press <Menu> to select ADD.
If there are entries in the phonebook, press <Up/Down> to the entry you want. Press <Menu> and <Up/Down> to select ADD.
3. Press <Menu> and enter the number.
4. Press <Menu> and enter the name.
5. Press <Menu> and <Up/Down> to select a melody.
6. Press <Menu> to save settings.

NOTE

Cancel storing an entry by pressing <Back> at any time during the process.

Entering names

Use the alphanumeric keypad to enter names in the phonebook.

For instance to enter the name Paul

- P Press <7> once
- A Press <2> once
- U Press <8> twice
- L Press <5> three times

To enter a space, press <1>.

Press <Clear/Delete> to delete a character or press and hold <Clear/Delete> to delete all characters.

Enter a pause

If your phone is connected to a switchboard, you may need to enter a pause in a stored number. This gives the switchboard time to get an outside line. A Pause is normally stored after the switchboard access code (e.g. 9).

When storing a number, press and hold <#> and the display shows P. You can then continue storing the phone number.

4.3 Edit an Entry

1. Press <Phonebook>.
2. Press <Up/Down> to the entry you want.
3. Press <Menu> and <Up/Down> to select EDIT.
4. Press <Menu> and edit the number.
5. Press <Menu> and edit the name.
6. Press <Menu> and <Up/Down> to select a melody.
7. Press <Menu> to save the entry.

NOTE

Press <Clear/Delete> to delete a digit/character or press and hold <Clear/Delete> to delete all digits/characters.

Doc Title :	Product Data – User’s Guide	Revision :	R.00
Model :	L401 series & L301 series	Page(s) :	20 of 38

4.4 Delete an Entry

1. Press <Phonebook>.
2. Press <Up/Down> to the entry you want.
3. Press <Menu> and <Up/Down> to select DELETE.
4. Press <Menu> to delete the entry.

4.5 Delete all Entries

1. Press <Phonebook>.
2. Press <Menu> and <Up/Down> to select DELETE ALL.
3. Press <Menu>. *DELETE ALL PH.BOOK RECORDS?* is displayed.
4. Press <Menu> to delete all the entries.

4.6 View Phonebook Capacity

1. Press <Phonebook>.
2. Press <Menu> and <Up/Down> to select PB CAPACITY.
3. Press <Menu>.

4.7 Store a Phonebook Entry as a One Touch Number

1. Press <Phonebook>.
2. Press <Menu> and <Up/Down> to select SPEED DIAL.
3. Press <Menu> and <Up/Down> to select the speed dial key 1 to 9.
4. Press <Menu> and <Up/Down> to the entry you want.
5. Press <Menu> to save.

4.8 Edit a Phonebook Entry in a One Touch Number

1. Follow steps 1 to 3 in **4.7 Store a Phonebook Entry as a One Touch Number**.
2. Press <Menu> and the stored number is displayed.
3. Press <Menu> to select ADD.
4. Press <Menu> and <Up/Down> to the entry you want.
5. Press <Menu> to save.

4.9 Delete a One Touch Number

1. Follow steps 1 to 3 in **4.7 Store a Phonebook Entry as a One Touch Number**.
2. Press <Menu> and the stored number is displayed.
3. Press <Menu> and <Up/Down> to select DELETE.
4. Press <Menu> to delete the stored number.

Doc Title :	Product Data – User’s Guide	Revision :	R.00
Model :	L401 series & L301 series	Page(s) :	21 of 38

5 CALLER ID

If you have subscribed to Caller ID, and provided the identity of the caller is not withheld, the number of the caller will be displayed together with the date and time of the call (if provided by the network).

NOTE

- If the caller’s number is stored in your phonebook along with a name, the name will also be displayed.
- If the telephone number is not available for incoming calls, the handset will display **UNAVAILABLE**.
- Information about incoming calls will vary by country and network operator. Some operators may charge a subscription for their Caller ID service.

5.1 Calls List

The calls list contains details of missed and received call. Details include the date and time of the call. Entries are displayed in chronological order with the most recent call at the top of the list.

NOTE

- When the calls list is full, a new call replaces the oldest in the list.
- The received and missed calls log holds details of up to 30 calls.
- If you receive more than one call from the same number, only the most recent call is kept in the calls list. When you have missed calls (incoming calls that you haven’t answered) the <NEW icon> will be displayed in the display on all handsets registered to the base. If one handset is used to view the calls log, the icon on the other handsets continue to display (Multipack user only).

5.1.1 View the calls list

1. Press <Call log> to enter calls list.

- *The most recent number or name if stored in the phonebook is displayed. New calls are marked with <NEW icon>.*

2. Scroll <Up/Down> through the calls list.

NOTE

- When reviewing an entry from the calls list, press <#> repeatedly to display the number in different format. For example, if a caller number is displayed as 888-883-2445, the various formats will be:

883-2445

1- 883-2445

888-883-2445

1-888-883-2445

User can choose the desired number format for local and long distance numbers before dialing or saving it into the phonebook.

- The <NEW icon> is removed once the new call has been viewed.

5.1.2 Save a number from the calls list to the phonebook

1. Press <Call log> to enter calls list.

2. Press <Up/Down> to the entry you want.

3. Press <Menu> and enter the name.

4. Press <Menu> and edit the number.

5. Press <Menu> and <Up/Down> to select a melody.

6. Press <Menu> to save.

5.1.3 Delete a calls list entry

1. Press <Call log> to enter calls list.

2. Press <Up/Down> to the entry you want.

3. Press <Clear/Delete> to delete the entry.

5.1.4 Delete entire calls list

1. Press <Call log> to enter calls list.

2. Press and hold <Clear/Delete>. *DELETE ALL CALL LOG ENTRIES?* is displayed.

3. Press <Menu> to confirm and all entries are deleted.

Doc Title :	Product Data – User’s Guide	Revision :	R.00
Model :	L401 series & L301 series	Page(s) :	22 of 38

5.2 Redial

Your phone lets you redial any of the last 5 numbers called. Numbers can be up to 32 digits long.

5.2.1 View the redial list

1. Press <Down/Redial> to enter the redial list. The last number dialed is displayed.
2. Scroll <Up/Down> through the redial list.

5.2.2 Copy a redial number to the phonebook

1. Press <Down/Redial> to enter the redial list.
2. Press <Up/Down> to select the entry you want.
3. Press <Menu> to select ADD TO PB.
4. Press <Menu> and enter the name.
5. Press <Menu> and edit the number.
6. Press <Menu> and <Up/Down> to select a melody.
7. Press <Menu> to save.

5.2.3 Delete a redial list entry

1. Press <Down/Redial> to enter the redial list.
 2. Press <Up/Down> to select the entry you want.
 3. Press <Clear/Delete> to delete the entry.
- OR
3. Press <Menu> and <Up/Down> to select DELETE. Press <Menu> again to delete the entry.

5.2.4 Delete entire redial list

1. Press <Down/Redial> to enter the redial list.
2. Press <Menu> and <Up/Down> to select DELETE ALL.
3. Press <Menu> and DELETE ALL? is displayed.
4. Press <Menu> to confirm and all entries are deleted.

Doc Title :	Product Data – User’s Guide	Revision :	R.00
Model :	L401 series & L301 series	Page(s) :	23 of 38

6 PERSONAL SETTINGS

6.1 Set Date & Time

Providing you have subscribed to your network's Caller ID service, the date and time is set automatically for all handsets every time a call is received. The date and time is recorded with each answering machine message you receive (for L401 series only). If you do not have a Caller ID service you can set the date and time manually.

1. Press <Menu> to select DATE & TIME.
2. Press <Menu> and edit the year and date.

TIPS

Alternatively, you can press <Up/Down> to move the cursor to toggle the input fields YEAR and DATE.

3. Press <Menu> and edit the time in 12hr format. Press <Up/Down> to toggle AM/PM settings.
4. Press <Menu> to save the settings.

6.2 Handset Tones

WARNING

When the phone is ringing, avoid holding the earpiece too close to your ear as it may damage your hearing.

6.2.1 Set the ringer tone

1. Press <Menu> and <Up/Down> to select SETUP HS.
2. Press <Menu> to select RINGER TONE.
3. Press <Menu> and <Up/Down> to select a ringer melody. *The current ringer melody is played for around 5 seconds.*
4. Press <Menu> to save.

6.2.2 Set the ringer volume

1. Press <Menu> and <Up/Down> to select SETUP HS.
2. Press <Menu> and <Up/Down> to select RINGER VOLUME.
3. Press <Up/Down> to increase or decrease the volume level. (6 levels are available, including ringer off. *The corresponding volume effect will be played while browsing the volume option.*)
4. Press <Menu> to save.

6.2.3 Key tones on/off

When you press a key on the handset you hear a beep. You can switch these beeps on or off.

1. Press <Menu> and <Up/Down> to select SETUP HS.
2. Press <Menu> and <Up/Down> to select KEY TONE.
3. Press <Menu> and <Up/Down> to turn on/off the key tone.
4. Press <Menu> to save.

6.2.4 Battery low tone on/off

1. Press <Menu> and <Up/Down> to select SETUP HS.
2. Press <Menu> and <Up/Down> to select LOW BATT TONE.
3. Press <Menu> and <Up/Down> to turn on/off the battery low tone.
4. Press <Menu> to save.

6.2.5 No coverage tone on/off

1. Press <Menu> and <Up/Down> to select SETUP HS.
2. Press <Menu> and <Up/Down> to select OUT RANGE TONE.
3. Press <Menu> and <Up/Down> to turn on/off the no coverage tone.
4. Press <Menu> to save.

6.3 Handset Name

Personalize your handset, with a name or location for example Peter or Bedroom. Maximum 14 characters.

1. Press <Menu> and <Up/Down> to select SETUP HS.
2. Press <Menu> and <Up/Down> to select HANDSET NAME.
3. Press <Menu> and enter the handset name.
4. Press <Menu> to save.

Doc Title :	Product Data – User’s Guide	Revision :	R.00
Model :	L401 series & L301 series	Page(s) :	24 of 38

NOTE

Handset name will be displayed in idle screen. A space and a handset number are automatically added after the name set.

6.4 Set the Display Language

You can change the display language.

1. Press <Menu> and <Up/Down> to select SETUP HS.
2. Press <Menu> and <Up/Down> to select LANGUAGE.
3. Press <Menu> and <Up/Down> to the language you want.
4. Press <Menu> to save.

6.5 Set the LCD Contrast

1. Press <Menu> and <Up/Down> to select SETUP HS.
2. Press <Menu> and <Up/Down> to select LCD CONTRAST.
3. Press <Menu> and <Up/Down> to increase or decrease the contrast level. (Five levels are available)
4. Press <Menu> to save.

6.6 Auto Talk On/Off

With auto talk is turned on, you can answer a call just by lifting the handset off the base or charger. If turned off, you will have to press <Talk on> or <Speaker> to answer a call. The default setting is Off.

1. Press <Menu> and <Up/Down> to select SETUP HS.
2. Press <Menu> and <Up/Down> to select AUTO TALK.
3. Press <Menu> and <Up/Down> to turn on/off auto talk.
4. Press <Menu> to save.

Doc Title :	Product Data – User’s Guide	Revision :	R.00
Model :	L401 series & L301 series	Page(s) :	25 of 38

7 ADVANCED SETTINGS

7.1 Set the Dial Mode

The default dialing mode is suitable for your country and network operator. It is unlikely that you should need to change this setting unless advised to do so.

1. Press <Menu> and <Up/Down> to select SETUP BS.
2. Press <Menu> to select DIAL MODE.
3. Press <Menu> and <Up/Down> to select TONE or PULSE.
4. Press <Menu> to save.

NOTE

If pulse mode is selected, press <*> to switch from pulse to tone dialing temporarily when dialing out. After the call is ended, the dial mode will resume to pulse.

7.2 Set the Flash Time

The default dialing mode is suitable for your country and network operator. It is unlikely that you should need to change this setting unless advised to do so.

1. Press <Menu> and <Up/Down> to select SETUP BS.
2. Press <Menu> and <Up/Down> to select FLASH TIME.
3. Press <Menu> and <Up/Down> to the flash time you want. (8 options are available: 90, 100, 110, 250, 300, 400, 600 and 700MS)
4. Press <Menu> to save.

7.3 Set the Area Code

1. Press <Menu> and <Up/Down> to select SETUP BS.
2. Press <Menu> and <Up/Down> to select AREA CODE.
3. Press <Menu> and enter the area code.
4. Press <Menu> to save.

7.4 Registration

Up to 5 handsets can be registered to one base station. Additional handsets must be registered to the base before you can use them.

7.4.1 Register a handset

The original handset is pre-registered to use. To register an additional handset,

1. Place the unregistered HS on the charger.
2. Press and hold <Find> for 4 seconds on Base.
3. Release <Find> once IN USE LED is flashing.
4. A confirmation tone is generated if registration is successful. HANDSET X is displayed where X denotes the number of handset and the phone goes back to idle.

7.4.2 De-register all handsets

1. Unplug the power from the base.
2. Press and hold <Find> on base for 10 seconds.
3. Plug the base power
4. Release once IN USE LED starts to flash rapidly.
5. Within 2 seconds, press and release <Find> on base again will de-register all handsets and the IN USE LED icon on base will be off. NOT REGISTERED is displayed on all handsets.

7.5 Reset All Settings

All personalized settings will be reset to default, but the date and time settings will be remained.

1. Press <Menu> and <Up/Down> to select RESET SETTINGS.
2. Press <Menu> and <Up/Down> to select ALL SETTINGS.
3. Press <Menu> to select YES
4. Press <Menu> to reset all settings to default.

Doc Title :	Product Data – User’s Guide	Revision :	R.00
Model :	L401 series & L301 series	Page(s) :	26 of 38

8 USING YOUR ANSWERING MACHINE (FOR L401 SERIES ONLY)

The answering machine records unanswered calls when it is activated. It can store up to 59 messages within the maximum recording time of 15 minutes. Each message can be up to 3 minutes long. Your personal outgoing messages can be up to 1 minute long.

8.1 Play Messages

Through the base:

1. Press <Play>.
2. The new messages are played from the loudspeaker on the base station in the sequence they are recorded.
3. Press <Volume +> or <Volume -> to increase or decrease the volume during message playback respectively.
4. During message playback, press below keys to perform the following functions:
 - <Play/Stop>: Press to playback or stop playing messages.
 - <Skip backward>: Press once to replay current message from the beginning. Press twice to playback the previous message.
 - <Skip forward>: Skip to play the next message.
 - <Delete>: Delete the current message.
 - <Volume +>: Increase the loudspeaker volume by one level (1 to 8).
 - <Volume ->: Decrease the loudspeaker volume by one level (1 to 8).

Through the handset:

1. Press <answering machine main menu> from idle mode.
2. Press <2> to play the messages.
3. During message playback, press the keys below to perform the following functions:
 - <1>: Skip to repeat playing the current message from the beginning.
 - <2>: Stop the current message playback.
 - <3>: Skip to play the next message.
 - <Volume +>: Increase the volume.
 - <Volume ->: Decrease the volume.
 - <Clear/Delete>: Delete the current message and the next message will be played.
 - <Speaker>: Toggle the message playback via earpiece/speakerphone.
 - <Talk off/Back>: Exit to idle.

8.2 Delete All Messages

1. Press and hold <Delete> on base to erase all read messages (applicable only when messages in answering machine are all read, new message(s) will not be deleted.)

NOTE

When answering machine is full, <answering machine icon> will flash if there are new messages which have not been listened. *ERASE SOME ANSWERER MSG* will toggle within 2 seconds with *MEMORY FULL* in idle to alert user to delete some answering machine messages to free up the memory.

8.3 Announcement

This is the message your callers hear on the answering machine. There are two pre-recorded outgoing messages, or you can record your own. For the pre-recorded messages, we will have English and Spanish messages for US, while have English and French for Canada.

8.3.1 Record the announcement

1. Press <Menu> and <Up/Down> to select ANSWER MACHINE.
2. Press <Menu> and <Up/Down> to select ANNOUNCEMENT.
3. Press <Menu> to select RECORD.
4. Press <Menu> and <Up/Down> to select the answer mode ANNC & RECORD or ANNOUNCE ONLY.
5. Press <Menu> to start recording after a “beep” sound is heard.
6. Press <Menu> again to stop recording and save the message. The just saved message is played automatically.

NOTE

When playing the message, press <Clear/Delete> will delete it and predefined message is played automatically.

8.3.2 Play the announcement

1. Press <Menu> and <Up/Down> to select ANSWER MACHINE.

Doc Title :	Product Data – User’s Guide	Revision :	R.00
Model :	L401 series & L301 series	Page(s) :	27 of 38

2. Press <Menu> and <Up/Down> to select ANNOUNCEMENT.
3. Press <Menu> and <Up/Down> to select PLAY.
4. Press <Menu> and <Up/Down> to select the answer mode ANNC & RECORD or ANNOUNCE ONLY.
5. Press <Menu> and the message is played.

NOTE

- When playing the message, press <Menu> to stop playing.
- When playing the message, press <Clear/Delete> will delete it and predefined message is played automatically.

8.4 Answering Machine Settings

8.4.1 Set the answer mode

1. Press <Menu> and <Up/Down> to select ANSWER MACHINE.
2. Press <Menu> to select ANSWER MODE.
3. Press <Menu> and <Up/Down> to select the answer mode you want. (3 options are available: ANSWER OFF, ANNC & RECORD and ANNOUNCE ONLY)

NOTE

ANNC & RECORD invites your callers to leave a message. ANNOUNCE ONLY lets callers hear your announcement but they cannot leave a message.

4. Press <Menu> to save.

8.4.2 Message alert on/off

1. Press <Menu> and <Up/Down> to select ANSWER MACHINE.
2. Press <Menu> and <Up/Down> to select MESSAGE ALERT.
3. Press <Menu> and <Up/Down> to turn on/off the message alert.
4. Press <Menu> to save.

8.4.3 Set the number of rings

1. Press <Menu> and <Up/Down> to select ANSWER MACHINE.
2. Press <Menu> and <Up/Down> to select NUMBER OF RINGS.
3. Press <Menu> and <Up/Down> to select the number of rings. (4 options are available: TOLL SAVER, 2 RINGS, 4 RINGS and 6 RINGS)

NOTE

If Toll Saver setting is selected, the answering machine will pick up after two rings if there are new messages and after four rings if there are no messages.

4. Press <Menu> to save.

8.4.4 Record a memo

You can record a memo which is stored on your answering machine and played back like a normal message.

1. Press <Menu> and <Up/Down> to select ANSWER MACHINE.
2. Press <Menu> and <Up/Down> to select RECORD MEMO.
3. Press <Menu> to start recording.
4. Press <Menu> again to stop recording and save the message. The just saved message is played automatically.

NOTE

When playing the message, press <Clear/Delete> will delete it.

8.4.5 Call screening on/off

Use your handset or base speaker to hear a caller leaving a message. You can then choose to ignore the caller or pick up the call.

1. Press <Menu> and <Up/Down> to select ANSWER MACHINE.
2. Press <Menu> and <Up/Down> to select CALL SCREENING.
3. Press <Menu> and <Up/Down> to turn on/off call screening.
4. Press <Menu> to save.

8.4.6 Remote access on/off

Remote access allows you to operate your answering machine and listen to your messages by calling your phone from another phone.

1. Press <Menu> and <Up/Down> to select ANSWER MACHINE.

2. Press <Menu> and <Up/Down> to select REMOTE ACCESS.
3. Press <Menu> and <Up/Down> to turn on/off remote access.
4. Press <Menu> to save.

The correct sequence of 3 digits of security PIN needs to be detected before entering remote access mode. Random digits detected prior to the correct 3 digits sequence are ignored, and answering machine recording continues until the complete PIN is detected. There is no system prompt to enter the remote access code.

Press the following keys to carry out your desired function after entering remote access mode.

Remote Access Mode

Keys on HS

1 Repeat	2 Play/Stop	3 Skip forward
4 Toggle Answer Off/Announce Only/Announce and Record modes	5	6
7 Listen to the Main Menu (for Full Voice prompts only)	8	9
*	0	#
N/A	Delete Message	N/A

8.4.7 Set the security code

This is used to change the remote access PIN if necessary.

1. Press <Menu> and <Up/Down> to select ANSWER MACHINE.
2. Press <Menu> and <Up/Down> to select SECURITY CODE.
3. Press <Menu> and enter the 3-digit security code.
4. Press <Menu> to save.

Doc Title :	Product Data – User’s Guide	Revision :	R.00
Model :	L401 series & L301 series	Page(s) :	29 of 38

9 DEFAULT SETTINGS

Items	Default values
Date & Time	Unchanged
Phonebook	Empty
Calls list	Empty
Redial list	Empty
Ringer tone	Melody 1
Ringer volume	Level 3
Earpiece volume	Level 1
Key tone	On
Battery low tone	On
No coverage tone	On
Handset name	HANDSET
Language	Country dependent
LCD contrast	Level 3
Auto talk	Off
Dial mode	Tone (country dependent)
Flash time	Country dependent (for US: 700ms as default)
Area code	- - -
Number of rings (for L401 series only)	4 rings
Remote access (for L401 series only)	On
Security code (for L401 series only)	123

Doc Title :	Product Data – User’s Guide	Revision :	R.00
Model :	L401 series & L301 series	Page(s) :	30 of 38

10 HELP

Charging

The <Battery icon> is not scrolling when the handset is placed on the base

- Bad battery contact – move the handset slightly.
- Dirty contact – Clean the battery contact with a cloth moistened with alcohol.
- Battery is full – no need to charge.

Calls

No dial tone

- No power – check the connections. Reset the phone: unplug and plug back in the electrical outlet.
- Batteries are empty – charge the battery pack for at least 24 hours.
- You are too far from the base – move closer to the base.
- Wrong telephone line cord – use the telephone line cord provided.
- Line adapter (when needed) is not connected to the telephone line cord – connect the line adapter (when needed) to the telephone line cord.

Poor audio quality

The base is too close to electrical appliances, reinforced concrete walls or metal doorframes – move the base away from any electrical appliances.

No ring tone

- The ring tone is deactivated.
- Increase the volume.

Caller ID service does not work

Check your subscription with your network operator.

Phonebook

A phonebook entry cannot be stored

The phonebook is full. Delete an entry to free memory.

Display

No display

- Try recharging or replacing the battery pack.
- Reset the telephone base. Unplug the unit’s electrical power, then plug it back in.
- If LED is not lit up, then try to unplug the unit’s electrical power, then plug it back in.

Registration

Unable to register another handset

- Maximum number of 5 handsets has been reached.
- The display shows **NOT REGISTERED**. You must unregister a handset in order to register a new one.

When the handset lost its link with the base during a call

- Check the power cord is connected properly into the telephone base.
- Check the power adapter is connected properly into an electrical outlet.
- Move the cordless handset closer to the telephone base. It may be out of range.
- Reset the telephone base by unplugging the unit’s electrical power. Wait for around 15 seconds and plug it back in again. Allow up to one minute for the cordless handset and the telephone base to synchronize.

Interference

Noise interference on your radio or television

Your base or charger may be too close. Move it as far away as possible.

Answering machine (for L401 series only)

Answering machine does not record messages

- Switch the answering machine on.
- The memory may be full. If so, you will need to delete some messages.

Doc Title :	Product Data – User’s Guide	Revision :	R.00
Model :	L401 series & L301 series	Page(s) :	31 of 38

- Answer mode may be set to **ANNOUNCE ONLY**.
- Change the mode to **ANNC & RECORD**.

Cannot access messages remotely

- Remote access may be switched off.
- If wrong security code is entered a beep is played. You can enter the security code once again.

Cannot record outgoing message

- The memory may be full. If so, you will need to delete some messages.

Answering machine stops automatically

- The memory may be full. If so, you will need to delete some messages.
- The maximum message length is 3 minutes.

Doc Title :	Product Data – User’s Guide	Revision :	R.00
Model :	L401 series & L301 series	Page(s) :	32 of 38

11 GENERAL INFORMATION

If your product is not working properly...

1. Read this User's Guide or the Quick Start Guide.
2. Visit our website: www.motorola.com
3. Contact Customer Service at US 1-317-345-9527 and Canada 905-831-6555.

To order a replacement battery contact customer service or visit our website as indicated in section 10 of the user's guide and section 4 of the quick start guide.

Important safety instructions

Follow these safety precautions when using your phone to reduce the risk of fire, electric shock, and injury to persons or property:

1. Keep all slits and openings of the phone unblocked. Do not set the phone on a heating register or over a radiator. Ensure that proper ventilation is provided at the installation site.
2. Do not use while wet or while standing in water.
3. Do not use this product near water (for example, near a bath tub, kitchen sink, or swimming pool).
4. Do not allow anything to rest on the power cord. Place the power cord so that it will not be walked on.
5. Never insert objects of any kind into the product slits as that may result in fire or shock.
6. Unplug this product from the wall outlet before cleaning. Do not use liquid cleaners or aerosol cleaners. Use a damp cloth for cleaning.
7. Do not disassemble this product. If service or repair work is required, contact the Motorola address found in this user's guide.
8. Do not overload wall outlets and extension cords.
9. Avoid using during an electrical storm. Use a surge protector to protect the equipment.
10. Do not use this phone to report a gas leak, especially if you are in the vicinity of the gas line.

CAUTION

To reduce the risk of fire, use only No. 26 AWG or larger UL Listed or CSA Certified Telecommunication Line Cord.

Unplug this cordless phone immediately from an outlet if:

- The power cord or plug is damaged or frayed.
- Liquid has been spilled into the product.
- The product has been exposed to rain or water. Do not retrieve the handset or base until after you have unplugged the power and phone from the wall. Then retrieve the unit by the unplugged cords.
- The product has been dropped or the cabinet has been damaged.
- The product exhibits a distinct change in performance.

Installation Guidelines

1. Read and understand all instructions and save them for future reference.
2. Follow all warnings and instructions marked on the product.
3. Do not install this product near a bath tub, sink, or shower.
4. Operate this phone using only the power source that is indicated on the marking label. If you are unsure of the power supply to your home, consult with your dealer or local power company.
5. Do not place this product on an unstable cart, stand, or table. This product may fall, causing serious damage to the product.
6. Adjust only those controls that are covered by the operating instructions. Improper adjustment of other controls may result in damage and will often require extensive work to restore the product to normal operation.
7. Clean this product with a soft, damp cloth. Do not use chemicals or cleaning agents to clean this phone.
8. Use only the power supply that came with this unit. Using other power supplies may damage the unit.
9. Because this phone operates on electricity, you should have at least one phone in your home that could operate without electricity in case the power in your home goes out.
10. To avoid interference to nearby appliances, do not place the base of the phone on or near a TV, microwave oven, or VCR.

CAUTION

To maintain compliance with the FCC's RF exposure guidelines, place the base unit at least 20 cm from nearby persons.

Doc Title :	Product Data – User’s Guide	Revision :	R.00
Model :	L401 series & L301 series	Page(s) :	33 of 38

Battery Safety Instructions

- Do not burn, disassemble, mutilate, or puncture the battery. The battery contains toxic materials that could be released, resulting in injury.

CAUTION

There is a risk of explosion if you replace the battery with an incorrect battery type. Use only the battery pack that came with your phone or an authorized replacement recommended by the manufacturer.

- Keep battery packs out of the reach of children.
- Remove battery packs if storing over 30 days.
- Do not dispose of battery packs in fire, which could result in explosion.
- The rechargeable battery packs that power this product must be disposed of properly and may need to be recycled. Refer to your battery’s label for battery type. Contact your local recycling center for proper disposal methods.

SAVE THESE INSTRUCTIONS

Consumer Products and Accessories purchased in the United States or Canada.

What Does this Warranty Cover?

Subject to the exclusions contained below, Binatone Electronics International LTD. warrants the Motorola branded consumer products that it manufactures (“Products”) and the Motorola branded or certified accessories sold for use with these Products that it manufactures (“Accessories”) to be free from defects in materials and workmanship under normal consumer usage for the period(s) outlined below. This limited warranty is a consumer’s exclusive remedy, and applies as follows to new Motorola branded Products and Accessories manufactured by Binatone Electronics International LTD., and purchased by consumers in the United States or Canada, which are accompanied by this written warranty:

Who is covered?

This warranty extends only to the first consumer purchaser, and is not transferable.

What will BINATONE ELECTRONICS INTERNATIONAL LTD. do?

BINATONE ELECTRONICS INTERNATIONAL LTD., at its option, will at no charge repair, replace or refund the purchase price of any Products or Accessories that does not conform to this warranty. We may use functionally equivalent reconditioned/ refurbished/ pre-owned or new Products, Accessories or parts.

What Other Limitations Are There?

ANY IMPLIED WARRANTIES, INCLUDING WITHOUT LIMITATION THE IMPLIED WARRANTIES OF MERCHANTABILITY AND FITNESS FOR A PARTICULAR PURPOSE, SHALL BE LIMITED TO THE DURATION OF THIS LIMITED WARRANTY, OTHERWISE THE REPAIR, REPLACEMENT, OR REFUND AS PROVIDED UNDER THIS EXPRESS LIMITED WARRANTY IS THE EXCLUSIVE REMEDY OF THE CONSUMER, AND IS PROVIDED IN LIEU OF ALL OTHER WARRANTIES, EXPRESS OF IMPLIED. IN NO EVENT SHALL MOTOROLA OR BINATONE ELECTRONICS INTERNATIONAL LTD. BE LIABLE, WHETHER IN CONTRACT OR TORT (INCLUDING NEGLIGENCE) FOR DAMAGES IN EXCESS OF THE PURCHASE PRICE OF THE PRODUCT OR ACCESSORY, OR FOR ANY INDIRECT, INCIDENTAL, SPECIAL OR CONSEQUENTIAL DAMAGES OF ANY KIND, OR LOSS OF REVENUE OR PROFITS, LOSS OF BUSINESS, LOSS OF INFORMATION OR OTHER FINANCIAL LOSS ARISING OUT OF OR IN CONNECTION WITH THE ABILITY OR INABILITY TO USE THE PRODUCTS OR ACCESSORIES TO THE FULL EXTENT THESE DAMAGES MAY BE DISCLAIMED BY LAW.

Some states and jurisdictions do not allow the limitation or exclusion of incidental or consequential damages, or limitation on the length of an implied warranty, so the above limitations or exclusions may not apply to you. This warranty gives you specific legal rights, and you may also have other rights that vary from state to state or from one jurisdiction to another.

Products Covered	Length of Coverage
Consumer Products	One (1) year from the date of purchase by the first consumer purchaser of the product.
Consumer Accessories	Ninety (90) days from the date of purchase by the first consumer purchaser of the product.
Consumer Products and Accessories that are Repaired or Replaced	The balance of the original warranty or for ninety (90) days from the date returned to the

Doc Title :	Product Data – User’s Guide	Revision :	R.00
Model :	L401 series & L301 series	Page(s) :	34 of 38

	consumer, whichever is longer.
--	--------------------------------

Exclusions

Normal Wear and Tear. Periodic maintenance, repair and replacement of parts due to normal wear and tear are excluded from coverage.

Batteries. Only batteries whose fully charged capacity falls below 80% of their rated capacity and batteries that leak are covered by this limited warranty.

Abuse & Misuse. Defects or damage that result from: (a) improper operation, storage, misuse or abuse, accident or neglect, such as physical damage (cracks, scratches, etc.) to the surface of the product resulting from misuse; (b) contact with liquid, water, rain, extreme humidity or heavy perspiration, sand, dirt or the like, extreme heat, or food; (c) use of the Products or Accessories for commercial purposes or subjecting the Product or Accessory to abnormal usage or conditions; or (d) other acts which are not the fault of Motorola or Binatone Electronics International LTD., are excluded from coverage.

Use of Non-Motorola branded Products and Accessories. Defects or damage that result from the use of Non-Motorola branded or certified Products or Accessories or other peripheral equipment are excluded from coverage.

Unauthorized Service or Modification. Defects or damages resulting from service, testing, adjustment, installation, maintenance, alteration, or modification in any way by someone other than Motorola, Binatone Electronics International LTD. or its authorized service centers, are excluded from coverage.

Altered Products. Products or Accessories with (a) serial numbers or date tags that have been removed altered or obliterated; (b) broken seals or that show evidence of tampering; (c) mismatched board serial numbers; or (d) nonconforming or non-Motorola branded housings, or parts, are excluded from coverage.

Communication Services. Defects, damages, or the failure of Products or Accessories due to any communication service or signal you may subscribe to or use with the Products or Accessories is excluded from coverage.

How to Obtain Warranty Service or Other Information?

To obtain service or information, please call:

US: <INSERT TOLL FREE NUMBER>
CANADA: <INSERT TOLL FREE NUMBER>

You will receive instructions on how to ship the Products or Accessories at your expense, to a BINATONE ELECTRONICS INTERNATIONAL LTD. Authorized Repair Center. To obtain service, you must include: (a) a copy of your receipt, bill of sale or other comparable proof of purchase; (b) a written description of the problem; and, most importantly; (c) your address and telephone number.

Manufactured under license of one or more of the following patents of Siemens AG - EP 0 667 077, EP 0667 078, EP 0667 088, EP 0667 089 and its corresponding foreign patents including US.

Doc Title :	Product Data – User’s Guide	Revision :	R.00
Model :	L401 series & L301 series	Page(s) :	35 of 38

Appendix

FCC, ACTA and IC regulations

FCC Part 15

This equipment has been tested and found to comply with the requirements for a Class B digital device under Part 15 of the Federal Communications Commission (FCC) rules. These requirements are intended to provide reasonable protection against harmful interference in a residential installation. This equipment generates, uses and can radiate radio frequency energy and, if not installed and used in accordance with the instructions, may cause harmful interference to radio communications. However, there is no guarantee that interference will not occur in a particular installation. If this equipment does cause harmful interference to radio or television reception, which can be determined by turning the equipment off and on, the user is encouraged to try to correct the interference by one or more of the following measures:

- Reorient or relocate the receiving antenna.
- Increase the separation between the equipment and receiver.
- Connect the equipment into an outlet on a circuit different from that to which the receiver is connected.
- Consult the dealer or an experienced radio/TV technician for help.

Changes or modifications to this equipment not expressly approved by the party responsible for compliance could void the user’s authority to operate the equipment.

This device complies with Part 15 of the FCC rules. Operation is subject to the following two conditions: (1) this device may not cause harmful interference, and (2) this device must accept any interference received, including interference that may cause undesired operation. Privacy of communications may not be ensured when using this telephone.

To ensure safety of users, the FCC has established criteria for the amount of radio frequency energy that can be safely absorbed by a user or bystander according to the intended usage of the product. This product has been tested and found to comply with the FCC criteria. The handset may be safely held against the ear of the user. The telephone base shall be installed and used such that parts of the user’s body other than the hands are maintained at a distance of approximately 20 cm (8 inches) or more.

This Class B digital apparatus complies with Canadian ICES-003.

FCC Part 68 and ACTA

This equipment complies with Part 68 of the FCC rules and with technical requirements adopted by the Administrative Council for Terminal Attachments (ACTA). The label on the back or bottom of this equipment contains, among other things, a product identifier in the format US: AAEEQ#TXXXX. This identifier must be provided to your local telephone company upon request.

The plug and jack used to connect this equipment to premises wiring and the telephone network must comply with applicable Part 68 rules and technical requirements adopted by ACTA. A compliant telephone cord and modular plug is provided with this product. It is designed to be connected to a compatible modular jack that is also compliant. An RJ11 jack should normally be used for connecting to a single line and an RJ14 jack for two lines. See Installation Instructions in the user’s manual.

The Ringer Equivalence Number (REN) is used to determine how many devices you may connect to your telephone line and still have them ring when you are called. The REN for this product is encoded as the 6th and 7th characters following the US: in the product identifier (e.g., if ## is 03, the REN is 0.3). In most, but not all areas, the sum of all RENs should be five (5.0) or less. For more information, please contact your local telephone company.

This equipment may not be used with Party Lines. If you have specially wired alarm dialing equipment connected to your telephone line, ensure the connection of this equipment does not disable your alarm equipment. If you have questions about what will disable alarm equipment, consult your telephone company or a qualified installer.

If this equipment is malfunctioning, it must be unplugged from the modular jack until the problem has been corrected. Repairs to this telephone equipment can only be made by the manufacturer or its authorized agents. For repair procedures, follow the instructions outlined under the Limited Warranty.

If this equipment is causing harm to the telephone network, the telephone company may temporarily discontinue your telephone service. The telephone company is required to notify you before interrupting service. If advance notice is not practical, you will be notified as soon as possible. You will be given the opportunity to correct the problem and the telephone company is required to inform you of your right to file a complaint with the FCC. Your telephone company may make changes in its facilities, equipment, operation, or procedures that could affect the proper functioning of this product. The telephone company is required to notify you if such changes are planned.

If this product is equipped with a corded or cordless handset, it is hearing aid compatible.

If this product has memory dialing locations, you may choose to store emergency telephone numbers (e.g., police, fire, medical) in these locations. If you do store or test emergency numbers, please:

Remain on the line and briefly explain the reason for the call before hanging up.

Perform such activities in off-peak hours, such as early morning or late evening.

Industry Canada

Operation is subject to the following two conditions: (1) this device may not cause harmful interference, and (2) this device must accept any interference, including interference that may cause undesired operation.

The term “IC: ” before the certification/registration number only signifies that the Industry Canada technical specifications were met.

The Ringer Equivalence Number (REN) for this terminal equipment is 0.1. The REN is an indication of the maximum number of devices allowed to be connected to a telephone interface. The termination on an interface may consist of any combination of devices subject only to the requirement that the sum of the RENs of all the devices does not exceed five.

This product meets the applicable Industry Canada technical specifications.

Doc Title	: Product Data – User’s Guide	Revision	: R.00
Model	: L401 series & L301 series	Page(s)	: 36 of 38

Appendix

RENSEIGNEMENTS RELATIFS AUX RÈGLEMENTS DE LA COMMISSION FÉDÉRALE DES COMMUNICATIONS ‘FCC’, DU CONSEIL ADMINISTRATIF DES UNITÉS DE CONNEXION ‘ACTA’ ET D’INDUSTRIE Canada ‘IC’

Article 15 des règlements du FCC

Cet appareil a été testé et s'avère conforme aux restrictions relatives aux équipements numériques de classe B, d'après l'article 15 des règlements de la FCC. Ces restrictions ont été instaurées pour offrir une protection raisonnable contre les interférences nuisibles au sein d'une installation résidentielle. Cet appareil génère, utilise et peut émettre des fréquences radio et s'il n'est pas installé selon les instructions, peut nuire aux radiocommunications. Toutefois, rien ne garantit que des parasites ne surviendront pas dans une installation particulière. Si cet appareil cause des interférences nuisibles à la réception du téléviseur ou de la radio, ce que vous pouvez déterminer en mettant votre appareil en et hors fonction, nous vous invitons à essayer l'une des mesures correctives suivantes :

- Réorientez l'antenne de réception.
- Éloignez l'appareil du composant qui reçoit les ondes.
- Branchez l'appareil dans une prise de courant CA différente de celle du composant qui reçoit les ondes.
- Au besoin, consultez votre marchand électronique ou un technicien spécialisé dans le service des radios/téléviseurs pour des suggestions supplémentaires.

Toute modification ou changement effectué à cet appareil sans l'accord des parties responsables de l'homologation peut retirer à l'utilisateur son droit d'utiliser l'appareil.

Cet appareil est conforme à l'article 15 de la FCC. Le fonctionnement est soumis aux deux conditions suivantes : (1) Cet appareil ne doit pas causer d'interférences nuisibles et; (2) Il doit pouvoir supporter les parasites qu'il reçoit, incluant les parasites pouvant nuire à son fonctionnement. La confidentialité des communications peut ne pas être assurée avec ce téléphone.

Afin de garantir la sécurité des utilisateurs, la FCC a établi les critères relatifs à l'énergie générée par les fréquences radio pouvant être absorbée en toute sécurité par un utilisateur ou par quelqu'un se trouvant à proximité, dépendamment de l'utilisation prévue du produit. Ce produit a été testé et s'avère conforme aux normes de la FCC. Le combiné produit si peu de puissance qu'il n'a pas besoin d'être testé. Il peut être déposé contre l'oreille de l'utilisateur en toute sécurité. Il peut être appuyé en toute sécurité sur l'oreille de l'utilisateur. Le socle doit être installé et utilisé de façon à ce qu'une distance d'environ 20 cm (8 po.) ou plus soit conservée entre celui-ci et les parties du corps de l'utilisateur, à l'exception des mains.

Cet appareil numérique de classe B est conforme aux normes canadiennes ICES-003.

Article 68 de la FCC et exigences de l'ACTA

Cet appareil est conforme à l'article 68 de la réglementation de la Commission fédérale des communications 'FCC' aux États-Unis et aux exigences adoptées par le Conseil d'administration du matériel terminal 'ACTA'. Vous trouverez, sous l'appareil, une étiquette qui contient, entre autres renseignements, une plaque signalétique dans le format 'US : AAAEQ##TXXXX'. Si on vous le demande, vous devez fournir ce numéro à la compagnie de téléphone. Cette homologation doit vous être fournie par votre compagnie de téléphone locale, sur demande.

La fiche et la prise utilisées pour brancher cet appareil au filage du bâtiment et au réseau téléphonique doivent être conformes avec les règlements de l'article 68 et les exigences techniques adoptées par l'ACTA. Un cordon téléphonique et une fiche modulaire conformes sont fournis avec cet appareil. Celui-ci a été conçu pour être raccordé à une prise modulaire compatible qui est également conforme. Une prise RJ11 doit être utilisée pour le raccord à une ligne simple et une prise RJ14, pour le raccord à deux lignes. Consultez les instructions d'installation du guide d'utilisation.

Doc Title :	Product Data – User’s Guide	Revision :	R.00
Model :	L401 series & L301 series	Page(s) :	37 of 38

Le numéro 'REN' sert à déterminer combien de dispositifs téléphoniques peuvent être raccordés à votre ligne téléphonique sans perdre leur capacité de sonner lorsqu'on vous appelle. Le numéro 'REN' de cet appareil est encodé entre le 6e et le 7e caractère après "US:" dans l'identification de l'appareil (par exemple, si les numéros sont 03, le REN sera 3.0). Dans la plupart, mais pas toutes les régions, la somme de tous les numéros 'REN' devrait être de cinq (5.0) ou moins. Pour plus de détails à ce sujet, nous vous suggérons de communiquer avec votre compagnie de téléphone locale.

Cet appareil ne peut pas être utilisé conjointement avec des lignes partagées. Si vous avez des composants de systèmes d'alarme connectés sur votre ligne téléphonique, assurez-vous que le raccord de cet appareil ne désactive pas votre système d'alarme. Si vous avez des questions se rapportant à ce qui peut désactiver votre système d'alarme, consultez votre compagnie de téléphone ou un installateur qualifié.

Si l'appareil s'avérait défectueux, il doit être immédiatement débranché de la prise modulaire jusqu'à ce que le problème soit corrigé. Cet appareil ne doit être réparé que par son fabricant ou l'un des centres de service autorisés par celui-ci. Pour plus de détails sur les procédures de service, suivez les instructions décrites dans la Garantie limitée.

Si cet appareil nuit au réseau téléphonique, la compagnie de téléphone peut décider d'arrêter temporairement votre service téléphonique. Elle est tenue de vous avertir avant d'interrompre le service ; si elle ne peut pas vous avertir d'avance, elle le fera dès qu'elle le pourra. On vous donnera l'opportunité de rectifier le problème et la compagnie doit vous informer de votre droit de porter plainte à la FCC. Votre compagnie de téléphone peut apporter des modifications à ses installations, ses équipements et ses procédures pouvant altérer le fonctionnement normal de votre appareil. Par contre, elle est tenue de vous avertir lorsque de tels changements sont prévus.

Si cet appareil est doté d'un combiné avec ou sans cordon, celui-ci est compatible avec les appareils auditifs pour malentendants.

Si cet appareil possède des adresses mémoire, vous pouvez y entrer les numéros de téléphone des services d'urgence de votre municipalité (police, incendie et services médicaux). Si vous entrez et testez des numéros d'urgence, veuillez procéder comme suit :

Demeurez en ligne et expliquez brièvement la raison de votre appel avant de raccrocher.

Procédez à ceci hors des heures de pointe, tel que tôt le matin ou tard en soirée.

Industrie Canada

Le fonctionnement est soumis aux deux conditions suivantes : (1) Cet appareil ne doit pas causer d'interférences nuisibles et; (2) Il doit pouvoir supporter les parasites qu'il reçoit, incluant les parasites pouvant nuire à son fonctionnement.

L'abréviation 'IC' se trouvant avant cette homologation signifie que la certification fut effectuée selon une déclaration de conformité spécifiant que les normes d'Industrie Canada ont été rencontrées.

Le numéro d'équivalence de sonnerie 'REN' assigné à cet appareil est 0.1. Ce numéro attribué à chaque appareil détermine le nombre de dispositifs téléphoniques que l'on peut brancher dans le circuit téléphonique de la maison sans surcharger le système. Le circuit téléphonique peut comporter n'importe quelle combinaison de dispositifs téléphoniques, à la seule condition que la somme du numéro 'REN' n'excède pas cinq.

Cet appareil est conforme aux spécifications techniques d'Industrie Canada.

Technical Specifications

	L301 series	L401 series
RF frequency band	1921.536 MHz – 1928.448 MHz	
Channels	5	
Operating temperature	5°C to 40°C	
Telephone base voltage (AC voltage, 60Hz)	96 – 130 Vms	
Telephone base voltage (Adapter output)	6V AC, 300mA	6V DC, 600mA
Handset voltage	2.0 – 2.9 VDC	
Charger voltage (Adapter output)	6V AC, 300mA	